

OVERALL SPECIFICATION

FLUID PORTS MAX. INLET PRESSURE at 23°C at 50°C CONTROLLED PRESSURE AMBIENT TEMPERATURE (°C) MAX. FLOW (P1=10 bar and P2=6,3bar - ΔP=1 bar) REGULATOR LUBRICATION BOWL CAPACITY	: Compressed air or neutral gas The compressed air used must be dry to prevent ice buildup : G3/4 to G1 1/2 : 17,5 bar : 12 bar : 0,5-12 bar, 0,5-16 bar, (0,5 - 4 bar) : -10°C to +50°C (+60°C at 12,5 bar) : G3/4 = 8600 l/mn - G1 = 14650 l/mn : Self-relieving : Selective oil fog : 520 cm ³
---	---

CONSTRUCTION

Filtering capacity 30 μm or 5 μm
 Semi-automatic or automatic drain, pipable (manual on request)
 Regulating device with flat diaphragm
 Lubricator oil refilling unpressurised/pressurised
 Metal bowl with polypropylene oil level viewing window

INDIVIDUAL SPECIFICATIONS AND CONSTRUCTION

Filter/regulator - lubricator: see following pages

CHOICE OF EQUIPMENT

Modulair range consists of two components (combined filter/regulator + lubricator, delivered assembled)

port size	maximum flow (ANR) at 6,3 bar pressure setpoint and ΔP of 1 bar/setpoint inlet pressure 8 bar				gauge dia.	code									
						min. (1)		max.		manual drain (5)		system semi-automatic drain		Automatic drain	
						(l/min)	(dm ³ /s)	(l/min)	(dm ³ /s)	with pressure gauge	without pressure gauge	with pressure gauge	without pressure gauge	with pressure gauge	without pressure gauge
30 μm filtration - adjustment range: 0,5 - 16 bar (2)															
G 3/4	90	1,5	7200	120	50	34207321	34207317	34207313	34207309	34207329	34207325				
G 1	90	1,5	10100	169	50	34207322	34207318	34207314	34207310	34207330	34207326				
G 1 1/4 ⁽⁴⁾	90	1,5	10100	169	50	34207323	34207319	34207315	34207311	34207331	34207327				
G 1 1/2 ⁽⁴⁾	90	1,5	10100	169	50	34207324	34207320	34207316	34207312	34207332	34207328				
5 μm filtration - adjustment range : 0,5 - 16 bar (2)															
G 3/4	90	1,5	6900	115	50	34207345	34207341	34207337	34207333	34207353	34207349				
G 1	90	1,5	9800	164	50	34207346	34207342	34207338	34207334	34207354	34207350				
G 1 1/4 ⁽⁴⁾	90	1,5	9800	164	50	34207347	34207343	34207339	34207335	34207355	34207351				
G 1 1/2 ⁽⁴⁾	90	1,5	9800	164	50	34207348	34207344	34207340	34207336	34207356	34207352				
30 μm filtration - adjustment range : 0,5 - 12 bar (3)															
G 3/4	90	1,5	7200	120	50	34207249	34207245	34207241	34207237	34207257	34207253				
G 1	90	1,5	10100	169	50	34207250	34207246	34207242	34207238	34207258	34207254				
G 1 1/4 ⁽⁴⁾	90	1,5	10100	169	50	34207251	34207247	34207243	34207239	34207259	34207255				
G 1 1/2 ⁽⁴⁾	90	1,5	10100	169	50	34207252	34207248	34207244	34207240	34207260	34207256				
5 μm filtration - adjustment range : 0,5 - 12 bar (3)															
G 3/4	90	1,5	6900	115	50	34207273	34207269	34207265	34207261	34207281	34207277				
G 1	90	1,5	9800	164	50	34207274	34207270	34207266	34207262	34207282	34207278				
G 1 1/4 ⁽⁴⁾	90	1,5	9800	164	50	34207275	34207271	34207267	34207263	34207283	34207279				
G 1 1/2 ⁽⁴⁾	90	1,5	9800	164	50	34207276	34207272	34207268	34207264	34207284	34207280				

- | | |
|--|---|
| (1) Minimum for lubricator startup
(2) 0-16 bar pressure gauge
(3) 0-12 bar pressure gauge | (4) The G 1 1/4 and G 1 1/2 versions are composed of a G 1 version + 1 set of 2 G 1 1/4 or G 1 1/2 flanges (1 connecting flange for each end of each component). When assembling several components together (FRL, isolation valve etc...), select G 1 components and provide for 1 set of G 1 1/4 or G 1 1/2 flanges (see "Accessories" pages)
(5) Metal manual drain |
|--|---|

ISOLATION VALVE, SHUT-OFF VALVE AND SOFT-START UNIT

OPTIONS FOR FILTER/REGULATOR

- Regulator designed to receive a key lock, code **662597**
- Key locking device attached to adjustment knob, supplied installed on regulator, code: **662593**
- Adjustment range: 0,5 to 4 bar, (provide 50 mm dia. 0 - 4 bar pressure gauge) code: **662567**

OTHER PRODUCT OPTIONS

- [Electronic pressure switch](#)
- [By-pass module](#)
- Key locking device (A), supplied separately for regulator designed to receive this accessory, code: **34303050**

ACCESSORIES (see following pages)

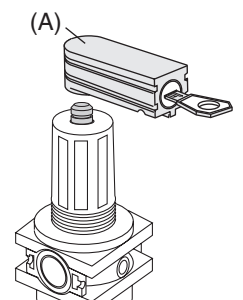

PRESSURE LOSS VERSUS AIR FLOW CURVES

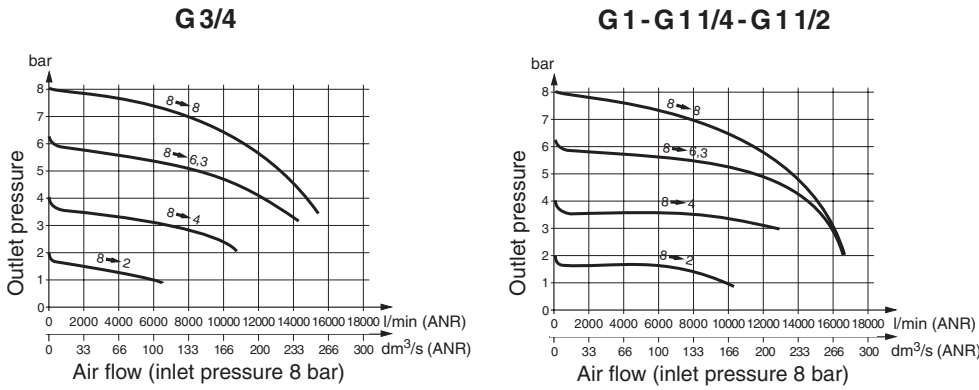

DIMENSIONS AND WEIGHTS - G3/4 - G1 VERSIONS

Weight: 2,8 kg

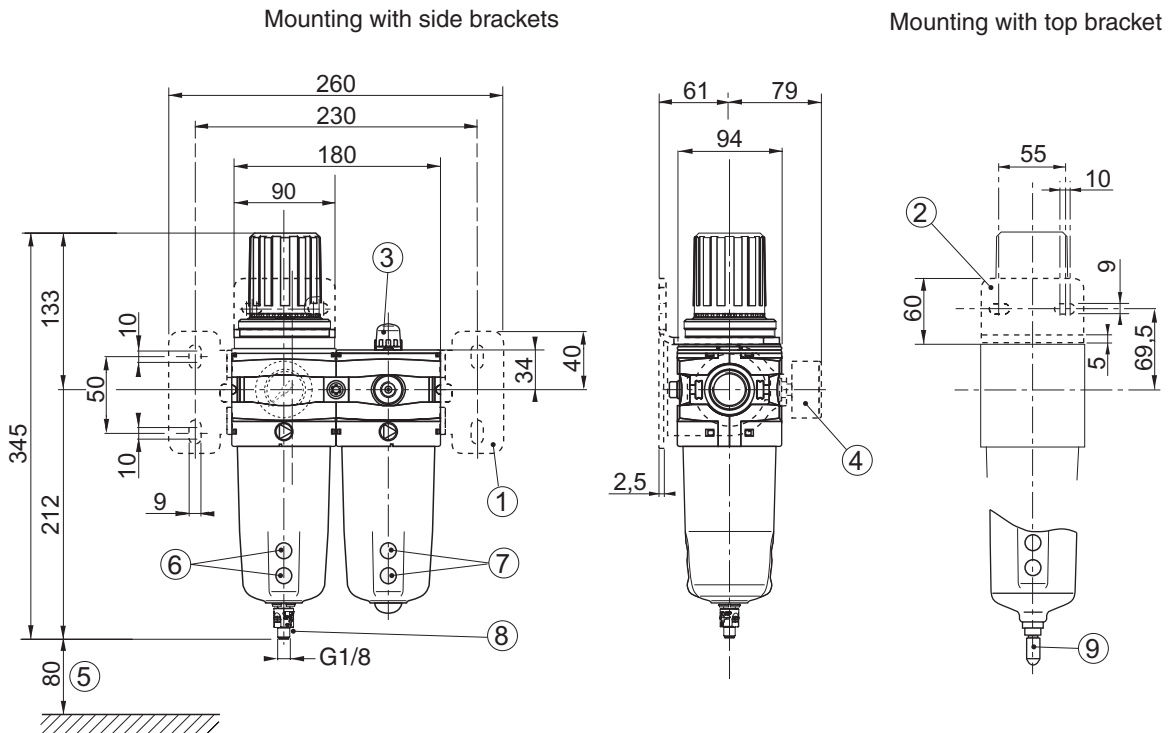

G 1 1/4 - G 1 1/2 versions - see accessories

- ① Mounting by 2 side brackets (accessory)
- ② Mounting by top bracket (accessory)
- ③ Sight dome
- ④ 50 mm dia. pressure gauge
- ⑤ Clearance required for bowl removal
- ⑥ Condensate level window
- ⑦ Oil min./max. level window
- ⑧ semi-automatic drain connectable G1/8
- ⑨ Automatic drain connectable to 6 mm ID flexible tubing

INSTALLATION AND MAINTENANCE

Systems must be installed with the bowls in vertical position (at the bottom).

Air flow direction indicated by arrow (►).

Recommended type of oil: non-detergent and without aggressive additives, viscosity VG32 (ISO 3448).

Use an alkaline solution (soapy water) and not a solvent for cleaning the polycarbonate bowls and sight glasses.