

Pre-production and sample electric vehicle auxiliary fuses — 500 Vdc, 5-50 A



Terminal styles

- Ferrule
- Axial bolt-on
- Flush bolt-on
- PCB terminal
- 6.3 mm quick connect
- 6.3 mm reverse quick connect
- 9.5 mm quick connect

Description

Eaton's Bussmann™ series Electric Vehicle (EV) full range fuses for protecting auxiliary electrical systems up to 500 Vdc in ratings from 20 to 50 amps.

Ratings

- Volts - 500 Vdc
- Amps
 - 5-50 A
- Interrupting rating
 - Max DC – 20 kA
 - Min DC 135%
- Operating temperature range -40°C to 125°C

Agency information

- Designed to:
 - JASO D622
 - ISO 8820-8
- Manufactured under a IATF 16949 quality system for compliance with automotive requirements
- RoHS compliant
- REACH declaration available upon request

Features

- Compact 10x38 mm size is easily mounted with multiple terminal options
- Higher voltage rating provides overall system efficiency using smaller, more economical conductors while meeting the needs of higher voltage battery packs
- Higher interrupting rating protects high capacity battery packs needed for vehicle acceleration and range requirements
- Operation as low as 135% overload provides full range protection for overload and high fault current conditions
- Can be selectively coordinated with upstream battery and charging circuit fuses

Recommended fuseclip for ferrule fuses

- 1A3400-10-R (see data sheet no. 2131)

Fuse ratings

| Fuse amps | Average @ 20 kA/500 Vdc | | Power loss (W) @ 50%* |
|-----------|--------------------------|---------------------------|--------------------------|
| | Melting I ² t | Clearing I ² t | |
| 20 | 761 | 1483 | 0.49 |
| 30 | 1150 | 2095 | 1.10 |
| 40 | 1720 | 3568 | 1.96 |
| 50 | 2740 | 5073 | 3.06 |

* 50 percent of fuse label amp rating tested at 23°C ± 2°C.

Available pre-production fuse catalog numbers

| Catalog no./terminals | | | | 6.3 mm quick connect | 6.3 mm reverse quick connect | 9.5 mm quick connect | Amps |
|-----------------------|---------------|---------------|-------------|----------------------|------------------------------|----------------------|------|
| Ferrule | Axial bolt-on | Flush bolt-on | PCB solder | | | | |
| XEV10-5 | XEV10-5-B | XEV10-5-T | N/A | N/A | N/A | N/A | 5 |
| XEV10-7.5 | XEV10-7.5-B | XEV10-7.5-T | N/A | N/A | N/A | N/A | 7.5 |
| XEV10-10 | XEV10-10-B | XEV10-10-T | XEV10-10-1P | XEV10-10-P | XEV10-10-RP | N/A | 10 |
| XEV10-20 | XEV10-20-B | XEV10-20-T | XEV10-20-1P | XEV10-20-P | XEV10-20-RP | N/A | 20 |
| XEV10-30 | XEV10-30-B | XEV10-30-T | XEV10-30-1P | XEV10-30-P | XEV10-30-RP | N/A | 30 |
| XEV10-40 | XEV10-40-B | XEV10-40-T | XEV10-40-1P | XEV10-40-P | XEV10-40-RP | N/A | 40 |
| XEV10-50 | XEV10-50-B | XEV10-50-T | XEV10-50-1P | XEV10-50-P | XEV10-50-RP | XEV10-50-P9 | 50 |

To order, contact your local Bussmann product sales representative or Bussmann Customer Service

Phone: 855-BUSSMANN (855-287-7626) M—F, 7:00 a.m. — 6:00 p.m., Central time

Email: BussCustSat@Eaton.com

For information on production fuses, contact your local Bussmann product sales representative.

Dimensions† — mm (nominal values)

10x38 mm ferrule



6.3 mm quick connect



10x38 mm axial bolt-on



6.3 mm reverse quick connect



10x38 mm flush bolt-on

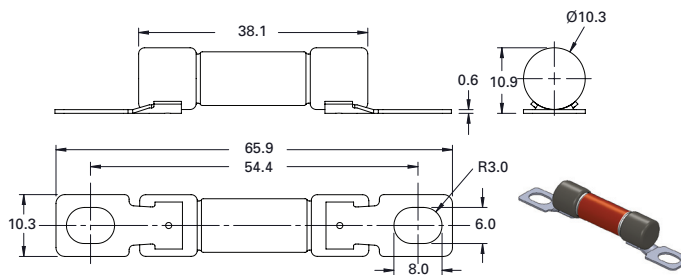

9.5 mm quick connect

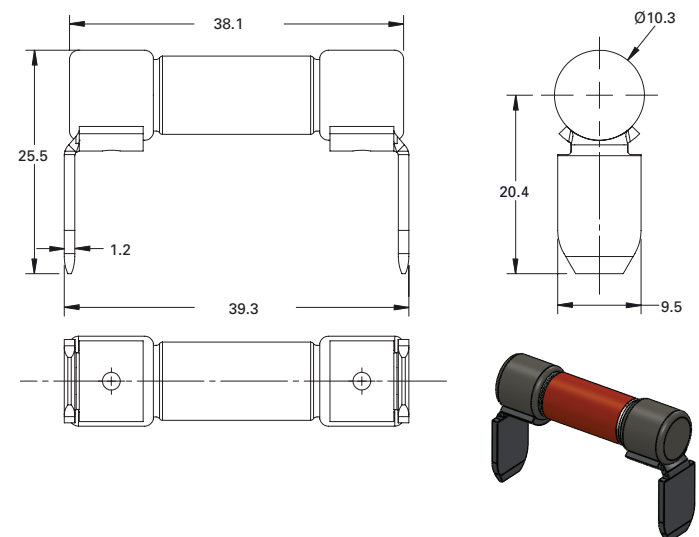

10x38 mm PCB terminal



PCB mounting hole pattern

DC minimum melt / maximum clearing time-current curves – multiple of rated current

For 20 to 50 amp fuses supplied via DC rectifier @ 500 Vdc and time constant (L/R) 2 ms ± 0.5 ms



Melting time correction factors



Power loss correction factors



The only controlled copy of this data sheet is the electronic read-only version located on the Eaton network drive. All other copies of this document are by definition uncontrolled. This bulletin is intended to clearly present comprehensive product data and provide technical information that will help the end user with design applications. Eaton reserves the right, without notice, to change design or construction of any products and to discontinue or limit distribution of any products. Eaton also reserves the right to change or update, without notice, any technical information contained in this bulletin. Once a product has been selected, it should be tested by the user in all possible applications.

Eaton
1000 Eaton Boulevard
Cleveland, OH 44122
Eaton.com

Bussmann Division
114 Old State Road
Ellisville, MO 63021
United States
Eaton.com/bussmannseries

© 2018 Eaton
All Rights Reserved
Printed in USA
Publication No. 10864 — BU-MC18090
December 2018

Eaton and Bussmann are valuable trademarks of Eaton in the US and other countries. You are not permitted to use the Eaton trademarks without prior written consent of Eaton.

For Eaton's Bussmann series product information, call **1-855-287-7626** or visit: **Eaton.com/bussmannseries**

Follow us on social media to get the latest product and support information.

