

ITEM 098775 CES-A-BPA

Description	Technical data	Accessories	Downloads
-------------	----------------	-------------	-----------

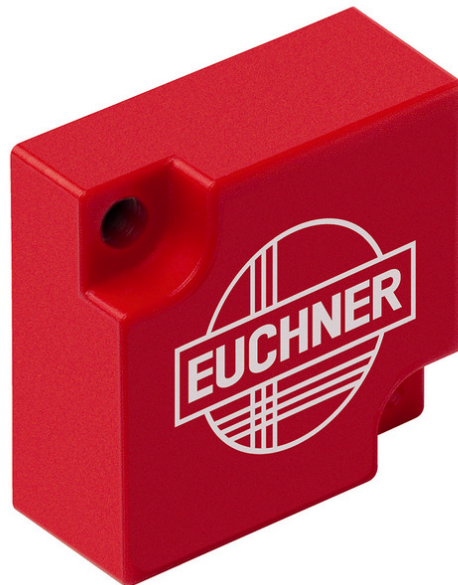

Features

- › Cube-shaped design 40 x 40 mm

Components included in the set

Supplied accessories

2x safety screws M5x10

Mechanical values and environment

Housing material	Plastic (PBT)
Weight	
	Net 0,025 kg
Ambient temperature	-25 ... 70 °C
Degree of protection	IP67/IP69K
Installation position	Active face opposite read head

Tightening torque

Fixing screws max.1 Nm

Electrical connection ratings

Power supply

Inductive via read head

Dimension drawing

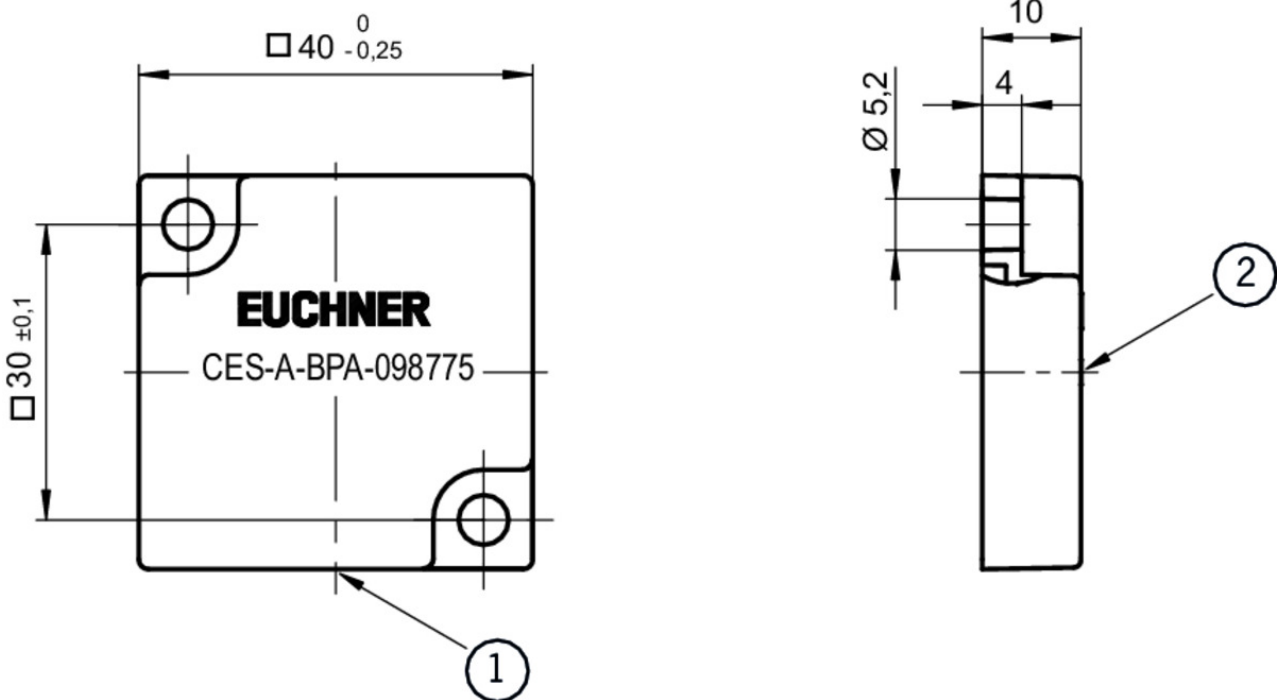

Mounting accessories

✓ Safety screws for actuators, M5 x 10

073455 M5X10-NIRO/V100 NZ/TZ

✓ Features

- › Safety screws M5 x 10
- › Packaging unit 100 pieces

Catalogs

✓ Transponder-coded safety switches - Interlocking devices and guard locking devices

Doc. no. Version Language Download

Transpondercodierte Sicherheitsschalter - Verriegelungseinrichtungen und Zuhaltungen	127594	01-09/16		 5.1 MB
Transponder-coded safety switches - Interlocking devices and guard locking devices	127595	01-09/16		 5.0 MB
Interrupteurs de sécurité à codage par transpondeur - Dispositifs de verrouillage et interverrouillages	137558	01-09/16		 5.0 MB
Interruptores de seguridad con codificación por transponder - Dispositivos de enclavamiento y bloqueos	137560	01-09/16		 5.0 MB

CAD data

CAD data for this item on TraceParts