

TemBreak

Total Protection, Complete Control

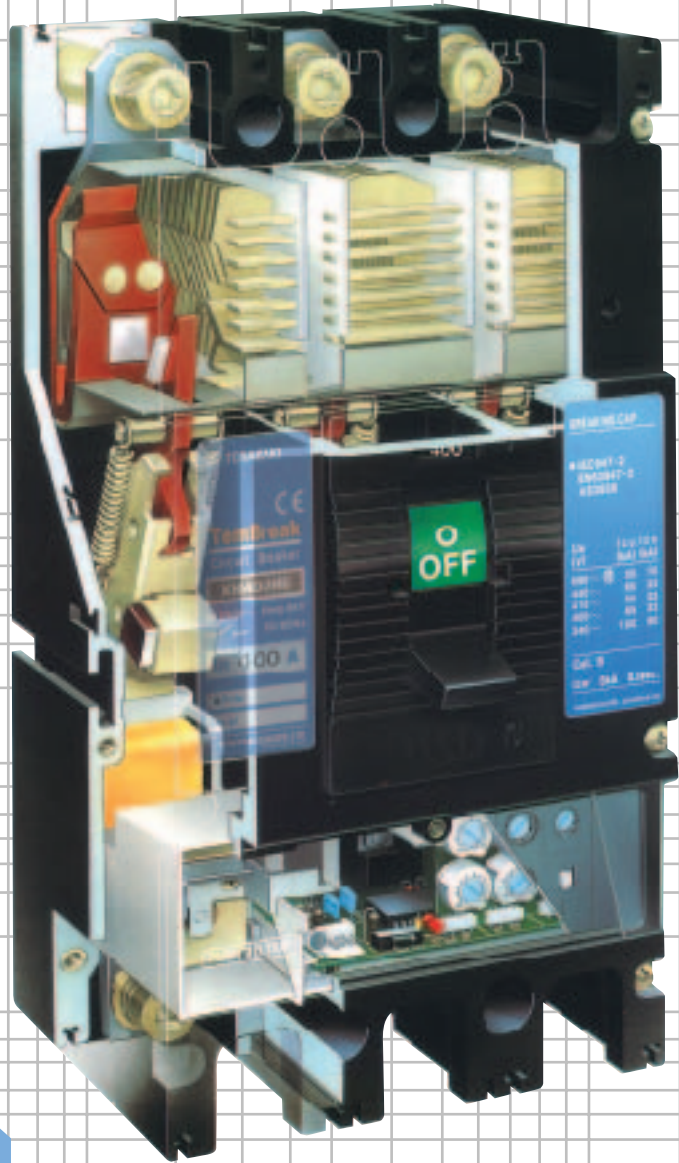



Terasaki Europe Ltd was established in 1971 and is located near Glasgow, Scotland U.K. From head office at our 7,500 square metre facility, Terasaki Europe controls an International Sales network.

The British managed facility manufactures the *Tempower* series of Air Circuit Breakers (ACB's), TemBreak Moulded Case Circuit Breakers (MCCB's) and a complete range of Distribution Switchboards.



Terasaki Europe Facility

The success of the Glasgow based operation has helped Terasaki become one of Europe's leading suppliers of circuit breaker technology, a fact reflected in our accreditation to the BS EN ISO 9002 quality management standard.



TemBreak MCCBs carry the  mark.

TemBreak MCCBs meet the following product standards:

[IEC 60947-2](#)

International Electrotechnical Commission

[BS EN 60947-2](#)

British Standards Institute



[JIS C 8370](#)

Japanese Industrial Standard

TemBreak MCCBs are approved by the following marine classification societies:

[Lloyds Register of Shipping](#)
[American Bureau of Shipping](#)
[Germanischer Lloyds](#)

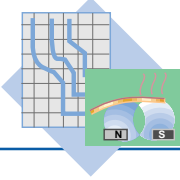
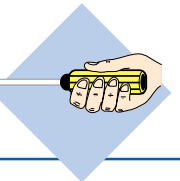
[Nippon Kaiji Kyokai](#)
[Bureau Veritas](#)
[Det Norske Veritas](#)

Section	Contents	Page
1	 Moulded Case Circuit Breaker Features	4-10
2	 Ratings and Specifications	11-22
3	 Thermal Magnetic Characteristics and Adjustments	23-36
4	 Microprocessor Based Characteristics and Adjustments	37-46
5	 Optional Accessories	47-84
6	 Connections and Mountings	85-102
7	 Outline Dimensions	103-118
8	 Catalogue Item Numbers	119-153

1

Profile

TemBreak

The Complete Solution for Thermal/Magnetic & Microprocessor MCCBs

Frame size	50	125	160	250	400	630	800	1000	1250	1600	2000	2500
XE Economical Series		XE100NS 10-100A 15kA 400V 10kA 415v		XE225NS 125-225A 18kA 400V 15kA 415v	XE400NS 250-400A 25kA 400V 25kA 415v	XE600NS 500-600A 25kA 400V 25kA 415v						
XS Standard Series		XS125CJ 12.5-125A 18kA 400v 14kA 415v			XS400CJ 160-400A 35kA 400V 35kA 415v	XS630CJ 250-630A 45kA 400V 35kA 415v						
	XS50NB 10-50A 15kA 400v 10kA 415v	XS125NJ 12.5-125A 30kA 400v 25kA 415v		XS250NJ 100-250A 35kA 400v 25kA 415v	XS400NJ 160-400A 50kA 400v 50kA 415v	XS630NJ 250-630A 65kA 400V 50kA 415v	XS800NJ 500-800A 65kA 400V 50kA 415v					
			XS160NJ 100-160A 35kA 400v 25kA 415v	XS250PJ 100-250A 35kA 400v 35kA 415v	XS400SE 125-400A 50kA 400v 50kA 415v	XS630SE 315-630A 50kA 400V 50kA 415v	XS800SE 400-800A 50kA 400V 50kA 415v		XS1250SE 500-1250A 85kA 400V 65kA 415v	XS1600SE 800-1600A 100kA 400V 85kA 415v	XS2000NE 1000-2000A 100kA 400V 85kA 415v	XS2500NE 1250-2500A 100kA 400V 85kA 415v
XH High Fault Series		XH125NJ 12.5-125A 50kA 400v 50kA 415v	XH160NJ 100-160A 50kA 400v 50kA 415v	XH250NJ 100-250A 50kA 400v 50kA 415v			XH800PS 700-800A 100kA 400V 85kA 415v					
				XH250PE 125-250A 65kA 400v 65kA 415v	XH400SE 125-400A 65kA 400v 65kA 415v	XH630SE 315-630A 65kA 400V 65kA 415v	XH800SE 400-800A 65kA 400V 65kA 415v	XS1000ND 1000A 30kA 350V 20kA 600v (D.C.)	XS1250ND 1250A 30kA 350V 20kA 600v (D.C.)	XS1600ND 1600A 30kA 350V 20kA 600v (D.C.)	XS2000ND 2000A 30kA 350V 20kA 600v (D.C.)	XS2500ND 2500A 30kA 350V 20kA 600v (D.C.)



End Suffix
S = Fixed Thermal Trip
J = Adjustable Thermal Trip
D = Special D.C. Application
E = Electronic Trip

Thermal Magnetic MCCBs still available at 400, 630 and 800 amps

1

Profile

TemBreak

Fast Break Mechanism, simple as **1** **2** **3**

EXCEPTIONAL CURRENT LIMITING, QUICK-BREAKING PERFORMANCE

TERASAKI'S ingenuity on current breaking is reflected in the new Fast Break Mechanism (FBM) of the TemBreak series. The current limiting, quick-breaking performance of TemBreak provides exceptional current-limiting characteristics that have not been possible with existing moulded case circuit breakers.

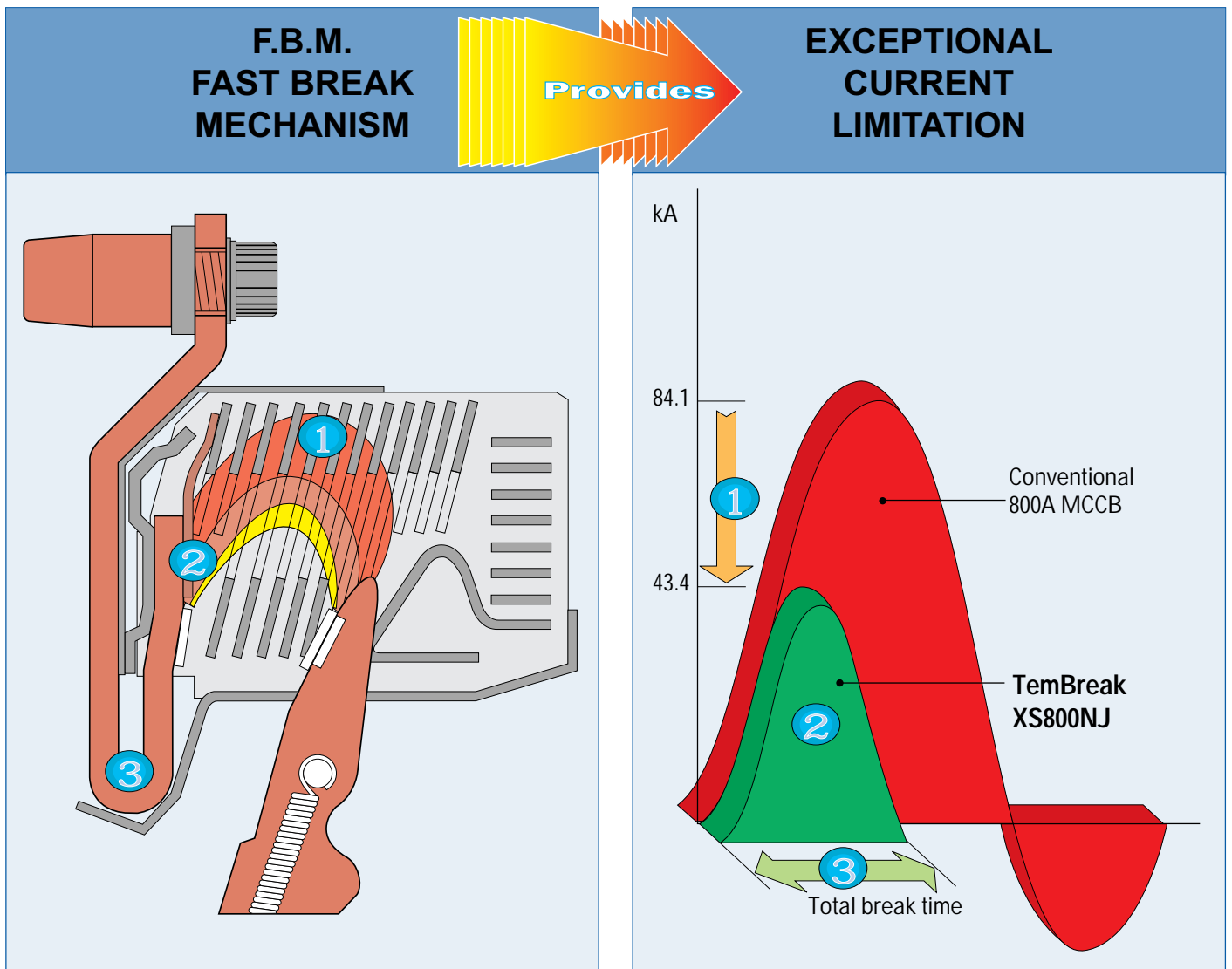

- 1** Quick-break arc chutes
- 2** Dual repulsive contacts
- 3** U-shaped conductors



- 1** Reduced Peak let through minimises electrodynamic stress on conductors
- 2** Reduced $\int i^2 dt$ energy let through minimises thermal stress on conductors
- 3** Reduced tripping time minimises damage after fault to both system and MCCB

"PIONEERS IN CURRENT LIMITING TECHNOLOGY"

1

Profile

TemBreak

Enhanced co-ordinated protection, the most flexible MCCB in the world

Very often, MCCBs must grade with other protective devices that may not have adjustable characteristics. This could be either a downstream fuse or an upstream electricity authority relay. Each microprocessor based TemBreak can achieve as standard over 200,000 independent time current characteristics. This unique curve flexibility enables TemBreak to achieve full selectivity even in the tightest of grading systems.

MICROPROCESSOR TIME CURRENT CHARACTERISTICS

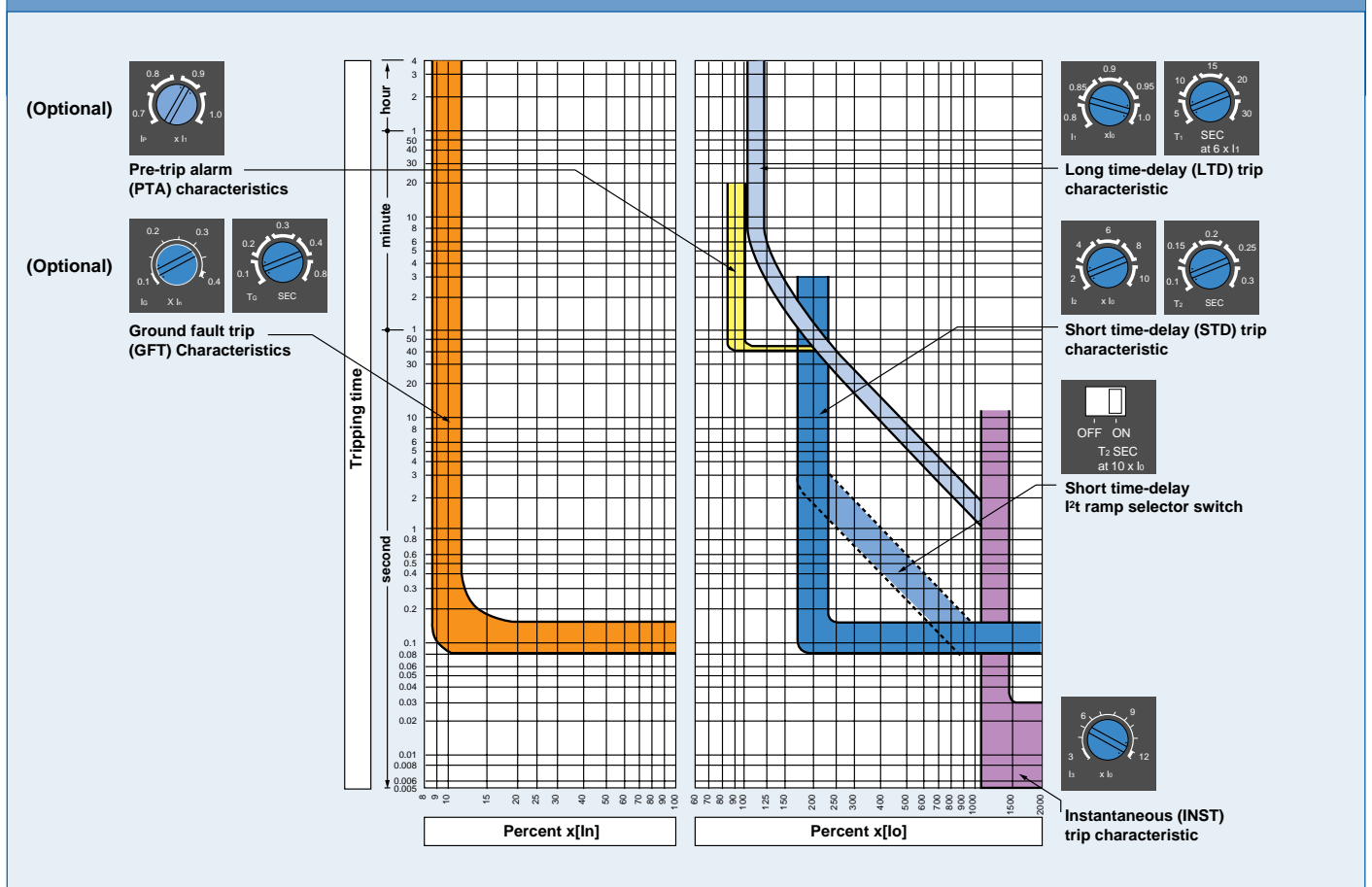

MICROPROCESSOR ADJUSTMENT FACIA

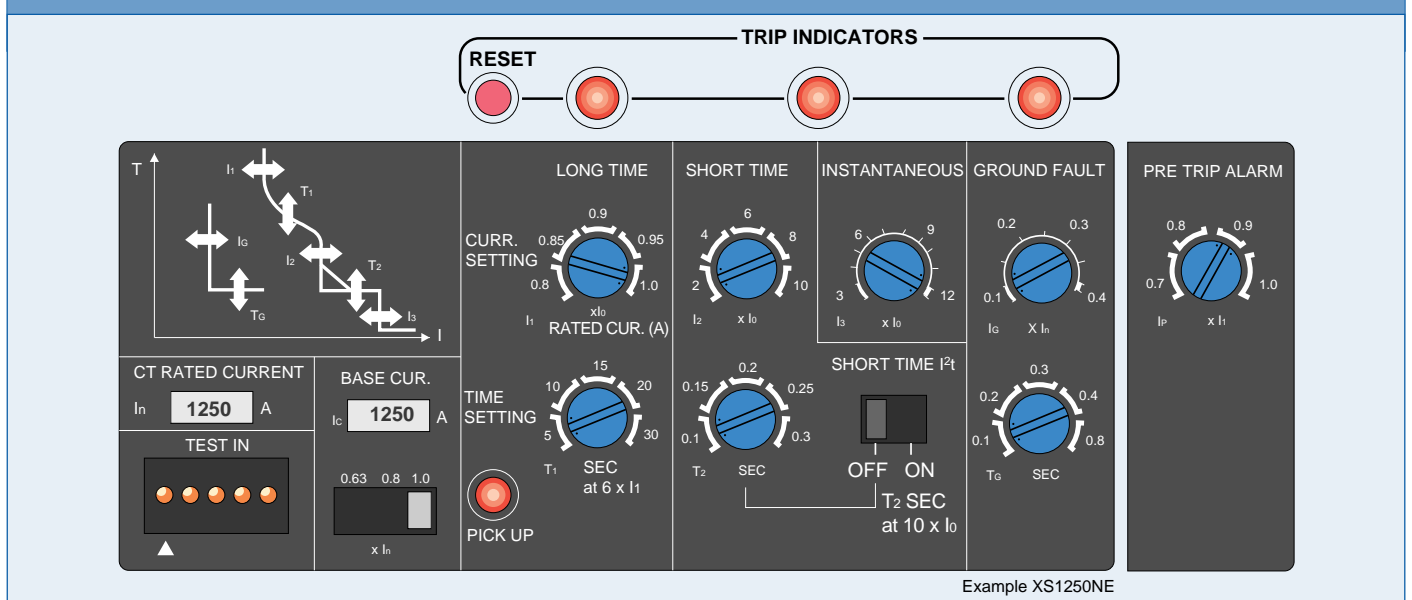

Example XS1250NE

1

Profile

TemBreak

All applications are met by...



In addition to TemBreak microprocessor MCCBs being the most flexible on the market, a number of important features are available as **STANDARD!** Most other MCCB manufacturers offer these relevant features at a premium price.

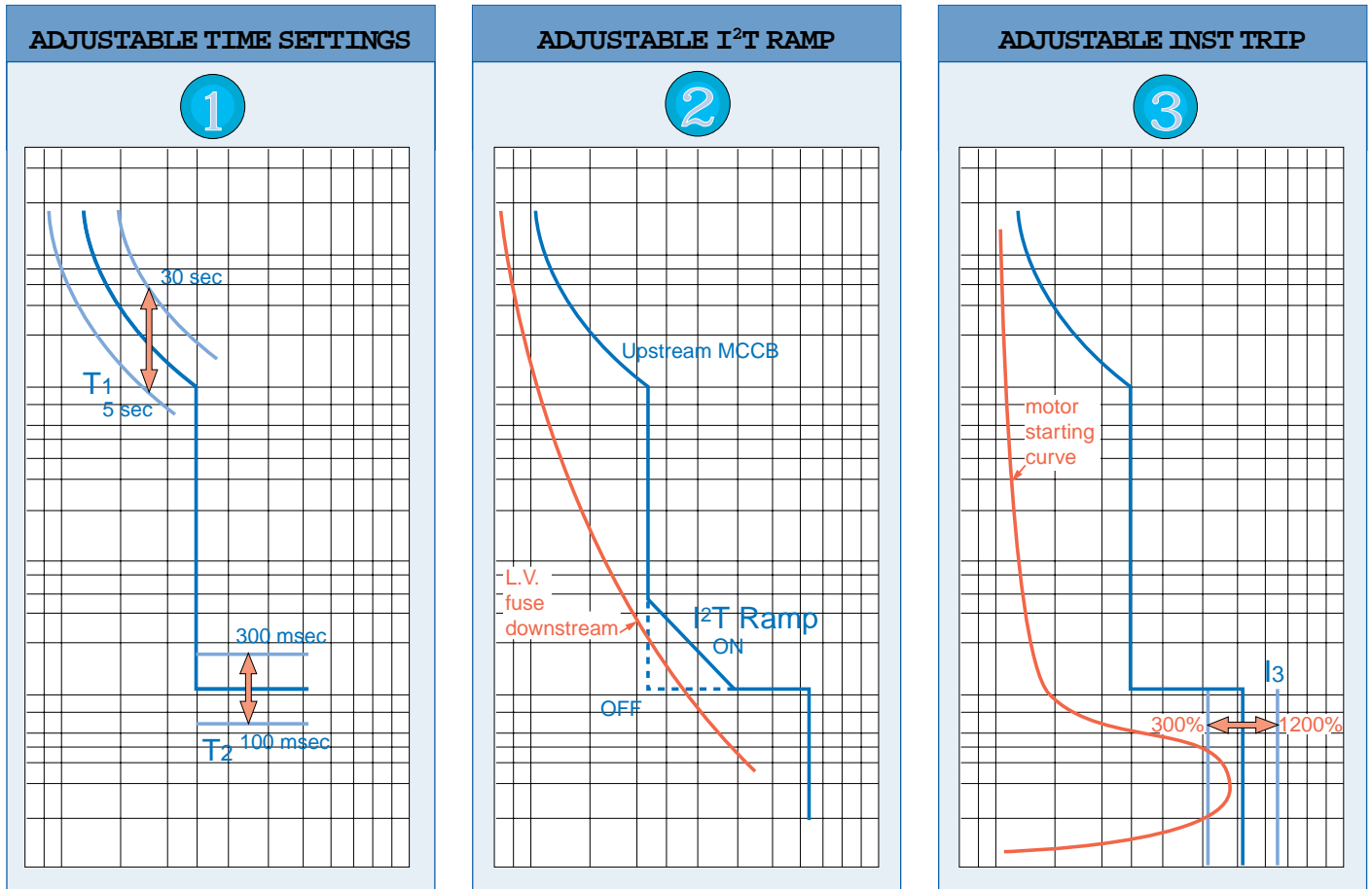

- 1** Provision of adjustable LTD T₁ settings and STD T₂ setting are important to match the protective characteristic to the load requirement. It is also extremely useful to provide flexible grading with other devices.
- 2** When co-ordinating between MCCB and fuses, it can often be difficult to obtain the required selectivity due to the different shape of the time current curves. With a flick of a switch the I²t ramp can be enabled to make grading easier.
- 3** Inductive loads such as motors often produce a transient inrush on initial switching. In this application it is important to have an adjustable instantaneous trip to set above this inrush current.

"INNOVATORS IN PROTECTION TECHNOLOGY"

1

Profile

TemBreak

From 10A to 2500A, TemBreak detects true r.m.s. as standard

Due to the amount of non-linear loads such as UPS, variable speed drives, soft starters & thyristor controls the level of harmonics in L.V. distribution is substantially increasing.

Conventional electronic MCCBs incorporating 'peak detection' are prone to nuisance tripping if Harmonic distortion exists.

TemBreak MCCBs employ a True R.M.S. detection through a process of sampling and integrating. Even those MCCBs that claim True R.M.S. may only do so up until the 3rd or 5th Harmonic. Ignoring higher frequency harmonics can lead to 'under protection' of the conductor. By utilizing a high sampling rate of 500 μ sec TemBreak microprocessor MCCBs detect up until and including the 19th Harmonic.

TRUE R.M.S. PROTECTION, UNEFFECTED BY HARMONICS

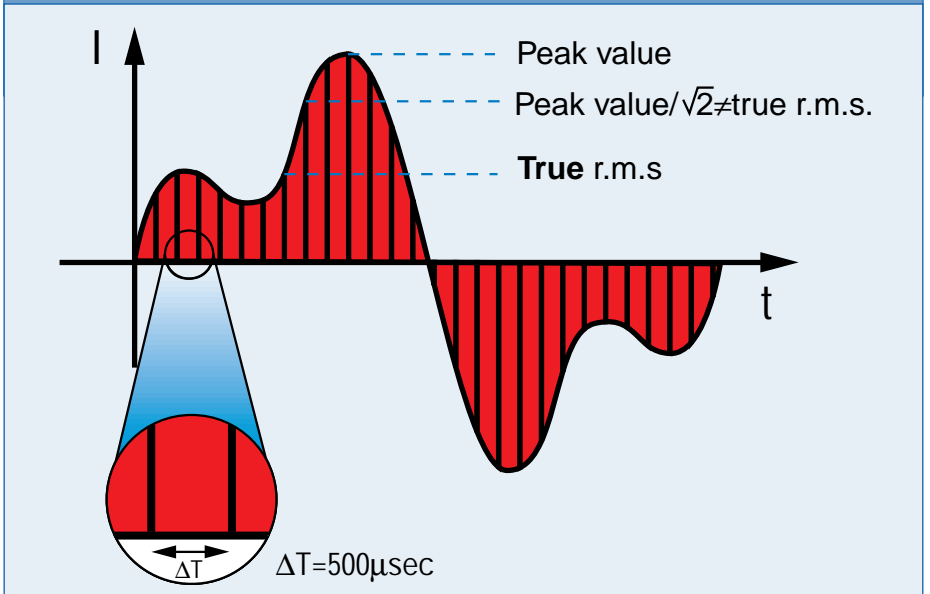

HIGH FREQUENCY HARMONICS DETECTED

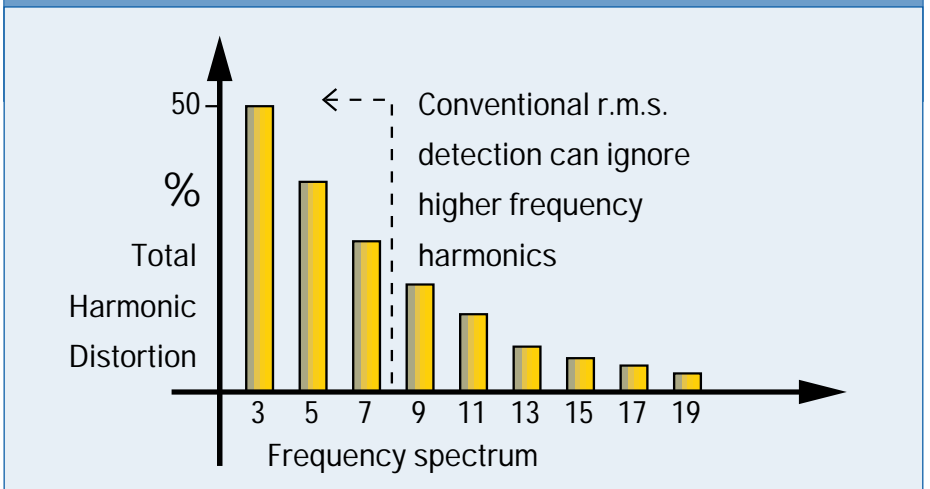

PRE-TRIP ALARM FUNCTION (OPTIONAL)

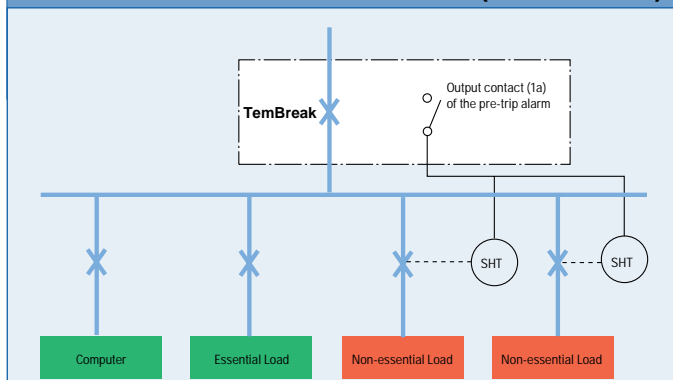

Electronic office equipment is being increasingly used in today's buildings and factories. The power demand at peak time can reach overload levels of the breakers installed in the system. If such a situation continued a sudden trip may be generated by the long time-delay trip function of the breaker. The pre-trip alarm prevents this "sudden trip" by tripping out non-essential loads thus ensuring an uninterrupted supply to essential loads.

1

Profile

TemBreak

Safety you can rely on, with choice of Protection

All TemBreak Plugin and drawout MCCBs are fitted with a safety trip as standard. If an attempt is made to remove an MCCB while ON it will automatically trip.



The neutral pole of all TemBreak MCCBs are of early make / late break design. This eliminates the risk of abnormal line to neutral voltages which may damage sensitive electronic equipment.

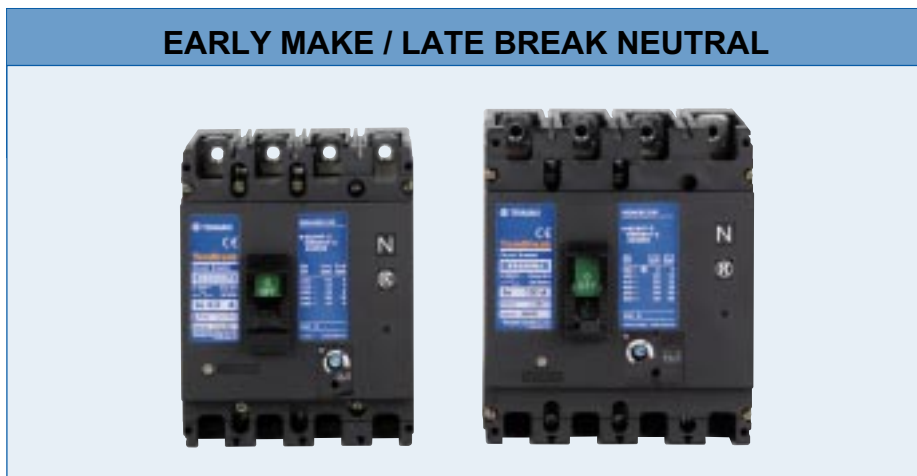

TemBreak MCCBs from 125AF to 1600AF are suitable for isolation as defined by IEC 947-2. Positive Contact Indication (PCI) is achieved via the toggle mechanism. Padlocks can only be installed if the contacts are fully open or closed.

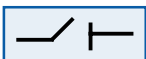
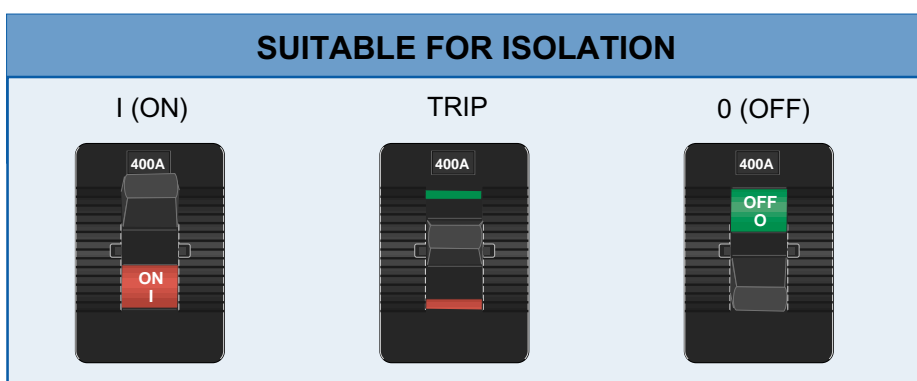

CHOICE OF PROTECTION

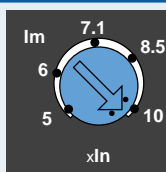

Thermal Adjustment
63% - 100% x In

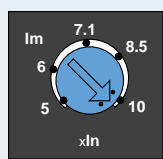

Magnetic Adjustment
500% - 1000% x In

Terasaki is one of the few manufacturers who can still offer a complete range of Thermal Magnetic MCCBs up to 800 AF. The thermal adjustment of the TemBreak range, 63% to 100% of the nominal rating, is one of the biggest on the market. This proven form of electromechanical technology still represents by far the largest type of MCCBs sold on the European Market. Wouldn't you prefer the choice?

ADDITIONAL TEMBREAK OPTIONS



TemWay Distribution Boards

TemWay 800 has been designed for today's modern distribution systems to give a fast, safe installation of a versatile sub distribution board yet still maintain a competitive price. A range of 3 phase and neutral panelboards with 6, 12 and 18 triple pole outgoing ways.

Catalogue No. '96 FDP 01E

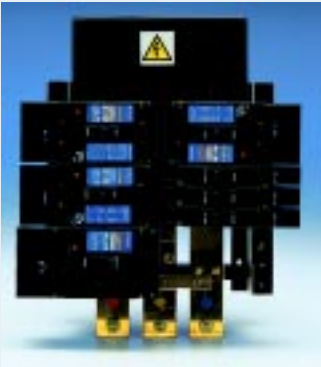

TemWay Pan Assemblies

TemWay 800 pan assembly has been designed for easy installation, ideal for switchboard manufacturers and a wide range of specifications. A short time withstand rating of 35kA or 50kA for 1 second makes this assembly one of the most versatile on the market. Busbar ratings are available at 800A and 1250A. Catalogue No. '96 FDP 01E

Add on Earth Leakage Block

- Wide range of current & time adjustments
- Trip/Non Trip option
- Pre Trip alarm function
- Local/Remote indication



TemTransfer Auto changeover Controller

TemTransfer is a fully configurable automatic supply transfer controller. It is designed to monitor the incoming AC mains supply for under/over voltage and under/over frequency. Should these fall out of limits, the TemTransfer will switch load from mains to generator.



NEW!

TEMCURVE 3

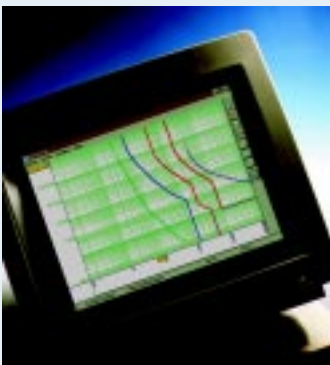

TemCurve 3 is a stand-alone selectivity analysis software package which has been formed around the extensive range of Terasaki circuit breakers, and also includes a large number of complimentary devices such as low and high voltage fuses, relays such as the Midos and CDG, commonly used in medium and high voltage systems

TemCurve 3 can therefore assist in protection grading from the transformer primary to the point of final distribution.

TemCurve 3 is suitable for use with Windows 95 and Windows 98.

NEW!

TEMMEASURE



The TemMeasure range offers a most cost effective solution to power management, incorporating measurement of electrical parameters into one compact unit. More than 80 electrical parameters can be monitored, including cubicle temperature.

Advanced models feature harmonic spectrum analysis and communication capability

Ratings and Specifications

11-22

• Economical series	12
• Standard series	13-15
• High-fault level series	16
• Switch Disconnecter series	17-18
• Mining series (1100v)	19
• D.C. Application series	20
• Motor Protection Series	21
• TemProtect and Earth Leakage Block	22



2

Ratings and Specifications

TemBreak

Economical Series

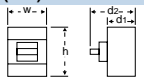
Ampere Frame	100	225	400	600				
Type	XE100NS	XE225NS	XE400NS	XE600NS				
Number of poles	2 3	3	3	3				
RATED CURRENT (A) [In]	*							
Calibrated at 45°C as standard, 50°C on request. (*: Calibrated at 40°C as standard, 45°C or 50°C on request)	10 30 60 15 40 75 20 50 100	125 200 150 225 175	250 400 300 350	500 600				
RATED IMPULSE WITHSTAND VOLTAGE Uimp [kV]	6	8	8	8				
AC RATED INSULATION VOLTAGE [U]	660	690	690	690				
AC RATED BREAKING CAPACITY sym. r.m.s. [kA]								
IEC 947-2 [Icu]	690V	—	—	—				
BS EN 60947-2 [Icu]	500V	7.5/3.8 ②	10/5 ②	15/7.5 ②	18/9 ②			
CEI EN 60947-2 [Icu]	440V	10/5	15/7.5	18/9	20/10			
IEC 947-2 [Ics]	690V	—	—	—	—			
BS EN 60947-2 [Ics]	500V	7.5/3.8 ②	10/5 ②	15/7.5 ②	18/9 ②			
CEI EN 60947-2 [Ics]	440V	10/5	15/7.5	18/9	20/10			
	415V	10/5	15/7.5	25/13	25/13			
	400V	15/7.5	18/9	25/13	25/13			
	380V	15/7.5	18/9	25/13	25/13			
	240V	25/13	25/13	35/18	35/18			
NEMA AB-1	600V	—	—	—	—			
	480V	—	15	18	20			
	240V	25	25	35	35			
Without Inst.	240-690V	—	—	—	—			
DC RATED BREAKING CAPACITY [kA] ①	250V	7.5	10	20	20			
	125V	15	15	20	20			
RATED SHORT TIME CURRENT r.m.s. [kA] [Icw]								
UTILIZATION CATEGORY	A	A	A	A				
OUTLINE DIMENSIONS (mm)								
	w	50 75	105	140	210			
	h	130	165	260	273			
	d1	68	86	103	103			
	d2	87	107	145	145			
Weight (kg) ④ marked standard type		0.48 0.74	1.85	4.7	9.0			
CONNECTIONS AND MOUNTINGS								
Front connected (FC)	Terminal screw (FCS)	④ ④	④	④	—			
	Attached flat bar (BAR)	—	④ (BAR)	④ (BAR)	④			
	Solderless terminal (PWC)	④	④	④	④			
Rear connected (RC)	Bolt stud (REB)	④	—	—	—			
	Flat bar stud (REF)	—	④	④	④			
Plug-in (PM)	For switchboard (PRC/PMB)	④	④	—	—			
	For distribution board	④	—	—	—			
Draw-out (DO)		—	—	—	—			
STANDARD FEATURES								
ON-OFF colour indication		•	•	•	•			
Trip button		•	•	•	•			
PROTECTIVE FUNCTIONS								
Electronic type								
Adjustable LTD, STD & INST.		—	—	—	—			
Adjustable GFT or Adjustable PTA (option)		—	—	—	—			
Trip Indicators (option)		—	—	—	—			
Thermal-magnetic type								
Thermal and fixed magnetic trips		• ⑦	•	—	—			
Thermal and adjustable magnetic trips		—	—	•	•			
Adjustable thermal and fixed magnetic trips		—	—	—	—			
Adjustable thermal and magnetic trips		—	—	—	—			
ACCESSORIES (option) CODE								
Internally mounted	Auxiliary switch	AX, AXE	•(AXE)	•(AXE)	•(AX)	•(AX)		
	Alarm switch	AL, ALE	•(ALE)	•(ALE)	•(AL)	•(AL)		
	Shunt trip	SHT	•	•	•	•		
	Undervoltage trip ③	UVT	•	•	•	•		
Externally mounted	Motor operator	MOT	—	•	•	•		
	Handle Panel mounted type	OHE	•	•	•	•		
	operating Breaker mounted type	OHJ	—	•	•	•		
	mechanism Variable depth type	OHH	—	•	•	•		
	Handle extension	EHA	—	—	—	•		
	Mechanical Front type	MIF	—	•	•	•		
	interlock Rear type	MIB	—	•	•	•		
	Handle holder	HH	•	•	•	•		
	Handle lock	HL	•	•	•	•		
	Terminal Front conn. type	TCF	•	•	•	•		
	cover Rear conn./ plug-in type	TCR	•	•	•	•		
	Interpole barrier	TBA	•	•	•	•		
	Accessory lead terminal	② LTF	—	•	•	•		
		② LTS	•	•	•	•		
	Door flange	D.F	•	•	•	•		
	IP20 Protection (Plug-in type)	IP20	•	•	•	•		

Notes:

- ④ : Standard. This configuration is used unless otherwise specified.
- ④ : Optional. Specify when ordering.
- : Yes or available.
- : No or not available.
- ① : DC rating available on request.
- ③ : Comes with conductor pressing terminal.
- ④ : Comes with conductor pressing terminal for 10-50A.

- ⑦ : Hydraulic-magnetic type for below 10A rating.
- ③ : For AC UVT, a UVT controller is mounted externally.
- ① : Applicable to the rear-connected type only.
- ② : Draw-out leads, horizontally.
- ② : Draw-out leads, vertically.
- ② : Not applicable to IT systems at voltage shown.

2

Ratings and Specifications

TemBreak

Standard Series

Ampere Frame	50	125	125	125	125	160	250	250
Type	XS50NB	XS125CS	XS125NS	XS125CJ	XS125NJ	XS160NJ	XS250NJ	XS250PJ
Number of poles	2 3	1	1	3 4	3 4	3 4	3 4	3 4
RATED CURRENT (A). [In]	*		NRC ASR		NRC ASR		NRC ASR	
Calibrated at 45°C as standard, 50°C on request. (*: Calibrated at 40°C as standard, 45°C or 50°C on request)	10 30 15 40 20 50	16 40 100 20 50 125 25 63 32 80	16 40 100 20 50 125 25 63 32 80	20 12.5 20 32 20 32 50 32 50 63 40 63 100 63 100 125 80 125	20 12.5 20 32 20 32 50 32 50 63 40 63 100 63 100 125 80 125	160 100 160	160 100 160 250 160 250	160 100 160 250 160 250
RATED IMPULSE WITHSTAND VOLTAGE Uimp [kV]	6	8	8	8	8	8	8	8
AC RATED INSULATION VOLTAGE [Uij]	660	690	690	690	690	690	690	690
AC RATED BREAKING CAPACITY sym. r.m.s. [kA]								
IEC 947-2 [Icu]	690V	-	-	-	5/2.5 (24)	8/4 (24)	8/4 (24)	8/4 (24)
BS EN 60947-2 [Ics]	500V	7.5/3.8 (24)	-	-	7.5/3.8 (24)	12/6 (24)	22/11 (24)	22/11 (24)
CEI EN 60947-2 [Icu]	440V	10/5	10/5 (23)	22/11 (23)	10/5	22/11 (24)	25/13 (24)	25/13 (24)
CEI EN 60947-2 [Ics]	415V	10/5	14/7 (23)	25/13 (23)	14/7	25/13	25/13	25/13
	400V	15/7.5	18/9 (23)	30/15 (23)	18/9	30/15	35/18	35/18
	380V	15/7.5	18/9 (23)	30/15 (23)	18/9	30/15	35/18	35/18
	240V	25/13	14/7 (23)	25/13	25/13	50/25	50/25	50/25
NEMA AB-1	600V	-	-	-	12	22	22	22
	480V	-	-	-	10	22	25	25
	240V	25	14 (24)	25 (25)	25	50	50	50
Without Inst.	240-690V	-	-	-	-	-	-	-
DC RATED BREAKING CAPACITY [kA] (1)	250V	7.5	-	-	10	15	40	40
	125V	15	10	15	15	20	40	40
RATED SHORT TIME CURRENT r.m.s. [kA] [Icw]	-	-	-	-	-	-	-	-
UTILIZATION CATEGORY	A	A	A	A	A	A	A	A
OUTLINE DIMENSIONS (mm)								
	w	50 75	30	30	90 120	90 120	105 140	105 140
	h	130	155	155	155	155	165	165
	d1	68	86	86	86	86	86	103
	d2	87	104	104	104	104	107	124
Weight (kg) (2) marked standard type	0.48 0.74	0.51	0.51	1.30 1.58	1.30 1.58	1.85 2.4	1.85 2.4	2.1 2.6
CONNECTIONS AND MOUNTINGS								
Front connected (FC)	Terminal screw (FCS)	(3)	(3)	(3)	(3)	(3)	(3)	(3)
	Attached flat bar (BAR)	-	-	-	-	(BAR)	(BAR)	(BAR)
	Solderless terminal (PWC)	(3)	(3)	(3)	(3)	(3)	(3)	(3)
Rear connected (RC)	Bolt stud (REB)	(3)	(3)	(3)	(3)	(3)	(3)	(3)
	Flat bar stud (REF)	-	-	-	-	(3)	(3)	(3)
Plug-in (PM)	For switchboard (PRC/PMB)	(3)	(3)	(3)	(3)	(3)	(3)	(3)
	For distribution board	(3)	(3)	(3)	(3)	(3)	(3)	(3)
Draw-out (DO)	-	-	-	-	-	-	-	(3)
STANDARD FEATURES								
ON-OFF colour indication	•	•	•	•	•	•	•	•
Trip button	•	•	•	•	•	•	•	•
PROTECTIVE FUNCTIONS								
Electronic type								
Adjustable LTD, STD & INST.	-	-	-	-	-	-	-	-
Adjustable GFT or Adjustable PTA (option)	-	-	-	-	-	-	-	-
Trip Indicators (option)	-	-	-	-	-	-	-	-
Thermal-magnetic type								
Thermal and fixed magnetic trips	•	•	•	-	-	-	-	-
Thermal and adjustable magnetic trips	-	-	-	-	-	-	-	-
Adjustable thermal and fixed magnetic trips	-	-	-	•	•	•	•	•
Adjustable thermal and magnetic trips	-	-	-	-	-	-	-	-
ACCESSORIES (option)	CODE							
Internally mounted	Auxiliary switch	AX,AXE	•(AXE)	-	•(AXE)	•(AXE)	•(AXE)	•(AXE)
	Alarm switch	AL,ALE	•(ALE)	-	•(ALE)	•(ALE)	•(ALE)	•(ALE)
	Shunt trip	SHT	•	•	•	•	•	•
	Undervoltage trip (3)	UVT	•	-	•	•	•	•
Externally mounted	Motor operator	MOT	-	•	•	•	•	•
	Handle operating mechanism	Panel mounted type OHE Breaker mounted type OHJ Variable depth type OHH	•	•	•	•	•	•
	Handle extension	EHA	-	-	-	-	-	-
	Mechanical interlock	Front type MIF Rear type MIB	-	•	-	•	•	•
	Handle holder	HH	•	•	•	•	•	•
	Handle lock	HL	•	•	•	•	•	•
	Terminal cover	Front conn. type TCF Rear conn./ plug-in type TCR	•	•	•	•	•	•
	Interpole barrier	TBA	•	-	• (2)	• (2)	• (2)	• (2)
	Accessory lead terminal	(2) LTF (2) LTS	•	-	-	-	-	-
	Door flange	D.F	•	•	•	•	•	•
	IP20 Protection (Plug-in type)	IP20	•	-	•	•	•	•

Notes:

NRC : Nominal Rated Current

ASR : Adjustable Setting Range

(3) : Standard. This configuration is used unless otherwise specified.

(3) : Optional. Specify when ordering.

• : Yes or available.

- : No or not available.

(1) : DC rating available on request.

(3) : Comes with conductor pressing terminal.

(3) : For AC UVT, a UVT controller is mounted externally.

(1) : Applicable to the rear-connected type only.

(2) : Line side interpole barriers are supplied as standard.

(3) : Value at 1/√3 times stated voltage.

(14) : 10 kA at 277V.

(15) : 22kA at 277V.

(16) : Available on request, contact Terasaki for details.

(22) : Draw-out leads, horizontally.

(23) : Draw-out leads, vertically.

(24) : Not applicable to IT systems at voltage shown.

2

Ratings and Specifications

TemBreak

Standard Series

Ampere Frame	400		400		400		400		630			630		
Type	XS400CJ		XS400NJ		XS400SE-C		XS400SE		XS630CJ			XS630NJ		
Number of poles	3 4		3 4		3 4		3 4		3 4			3 4		
RATED CURRENT (A) [In]	NRC ASR		NRC ASR		NRC ASR		NRC ASR		NRC ASR			NRC ASR		
Calibrated at 45°C as standard, 50°C on request.														
RATED IMPULSE WITHSTAND VOLTAGE Uimp [kV]	8		8		8		8		8			8		
AC RATED INSULATION VOLTAGE [Ui]	690		690		690		690		690			690		
AC RATED BREAKING CAPACITY sym. r.m.s. [kA]														
IEC 947-2 [Icu]	690V		16/8 ⑳		16/8 ⑳		18/9 ㉑		16/8 ㉑			20/10 ㉑		
BS EN 60947-2 [Icu]	500V		22/11 ㉒		30/15 ㉒		22/11 ㉒		30/15 ㉒			25/13 ㉒		
CEI EN 60947-2 [Icu]	440V		30/15		42/21		30/15		42/21			30/15		
IEC 947-2 [Ics]	690V		16/8 ㉓		16/8 ㉓		18/9 ㉓		16/8 ㉓			20/10 ㉓		
BS EN 60947-2 [Ics]	500V		22/11 ㉔		30/15 ㉔		22/11 ㉔		30/15 ㉔			25/13 ㉔		
CEI EN 60947-2 [Ics]	440V		30/15		42/21		30/15		42/21			30/15		
	415V		35/18		50/25		35/18		50/25			35/18		
	400V		35/18		50/25		35/18		50/25			45/23		
	380V		35/18		50/25		35/18		50/25			45/23		
	240V		50/25		85/43		50/25		85/43			50/25		
NEMA AB-1	600V		22		30		22		25			30		
	480V		30		42		30		35			50		
	240V		50		85		50		50			85		
Without Inst.	240-690V		-		-		5		-			-		
DC RATED BREAKING CAPACITY [kA]	125V		50		50		-		50			50		
RATED SHORT TIME CURRENT r.m.s. [kA] [Icw]	-		-		-		5 (0.3 sec)		-			-		
UTILIZATION CATEGORY	A		A		B		B		A			A		
OUTLINE DIMENSIONS (mm)														
	w	140 185	140 185	140 185	140 185	210 280	210 280							
	h	260	260	260	260	273	273							
	d1	103	103	103	103	103	103							
	d2	145	145	145	145	145	145							
Weight (kg) ㉕ marked standard type	4.7 6.1		4.7 6.1		4.8 6.2		4.8 6.2		9.0 11.5			9.0 11.5		
CONNECTIONS AND MOUNTINGS														
Front connected (FC)	Terminal screw (FCS)	⓪	⓪	⓪	⓪	⓪	⓪	⓪	⓪	⓪	⓪	⓪	⓪	
	Attached flat bar (BAR)	⓪ (BAR)	⓪ (BAR)	⓪ (BAR)	⓪ (BAR)	⓪ (BAR)	⓪ (BAR)	⓪	⓪	⓪	⓪	⓪	⓪	
	Solderless terminal (PWC)	⓪	⓪	⓪	⓪	⓪	⓪	⓪	⓪	⓪	⓪	⓪	⓪	
Rear connected (RC)	Bolt stud (REB)	⓪	⓪	⓪	⓪	⓪	⓪	⓪	⓪	⓪	⓪	⓪	⓪	
	Flat bar stud (REF)	⓪	⓪	⓪	⓪	⓪	⓪	⓪	⓪	⓪	⓪	⓪	⓪	
Plug-in (PM)	For switchboard (PRC/PMB)	⓪	⓪	⓪	⓪	⓪	⓪	⓪	⓪	⓪	⓪	⓪	⓪	
	For distribution board	⓪	⓪	⓪	⓪	⓪	⓪	⓪	⓪	⓪	⓪	⓪	⓪	
Draw-out (DO)		⓪ ㉖	⓪ ㉖	⓪ ㉖	⓪ ㉖	⓪ ㉖	⓪ ㉖	⓪ ㉖	⓪ ㉖	⓪ ㉖	⓪ ㉖	⓪ ㉖	⓪ ㉖	
STANDARD FEATURES														
ON-OFF colour indication	•		•		•		•		•			•		
Trip button	•		•		•		•		•			•		
PROTECTIVE FUNCTIONS														
Electronic type														
Adjustable LTD, STD & INST.	-		-		-		-		-			-		
Adjustable GFT or Adjustable PTA (option)	-		-		• (PTA only)		• (PTA only)		-			-		
Trip Indicators (option)	-		-		• ㉗		• ㉗		-			-		
Thermal-magnetic type														
Thermal and fixed magnetic trips	-		-		-		-		-			-		
Thermal and adjustable magnetic trips	-		-		-		-		-			-		
Adjustable thermal and fixed magnetic trips	-		-		-		-		-			-		
Adjustable thermal and magnetic trips	•		•		-		-		•			•		
ACCESSORIES (option)														
Internally mounted	Auxiliary switch	AX,AXE	•(AX)	•(AX)	•(AX)	•(AX)	•(AX)	•(AX)	•(AX)	•(AX)	•(AX)	•(AX)	•(AX)	
	Alarm switch	AL,ALE	•(AL)	•(AL)	•(AL)	•(AL)	•(AL)	•(AL)	•(AL)	•(AL)	•(AL)	•(AL)	•(AL)	
	Shunt trip	SHT	•	•	•	•	•	•	•	•	•	•	•	
	Undervoltage trip ㉘	UVT	•	•	•	•	•	•	•	•	•	•	•	
Externally mounted	Motor operator	MOT	•	•	•	•	•	•	•	•	•	•	•	
	Handle operating mechanism	Panel mounted type Breaker mounted type Variable depth type	OHE OHJ OHH	• • •	• • •	• • •	• • •	• • •	• • •	• • •	• • •	• • •	• • •	
	Handle extension	EHA	•	•	•	•	•	•	•	•	•	•	•	
	Mechanical interlock	Front type Rear type	MIF MIB	• •	• •	• •	• •	• •	• •	• •	• •	• •	• •	
	Handle holder	HH	•	•	•	•	•	•	•	•	•	•	•	
	Handle lock	HL	•	•	•	•	•	•	•	•	•	•	•	
	Terminal cover	Front conn. type Rear conn./ plug-in type	TCF TCR	• •	• •	• •	• •	• •	• •	• •	• •	• •	• •	
	Interpole barrier	TBA	• ㉙	• ㉙	• ㉙	• ㉙	• ㉙	• ㉙	• ㉙	• ㉙	• ㉙	• ㉙	• ㉙	
	Accessory lead terminal	㉚ LTF	•	•	•	•	•	•	•	•	•	•	•	
		㉛ LTS	•	•	•	•	•	•	•	•	•	•	•	
	Door flange	D.F	•	•	•	•	•	•	•	•	•	•	•	
	IP20 Protection (Plug-in type)	IP20	•	•	•	•	•	•	•	•	•	•	•	

Notes:

- NRC : Nominal Rated Current
- ASR : Adjustable Setting Range
- ⓪ : Standard. This configuration is used unless otherwise specified.
- ⓪ : Optional. Specify when ordering.
- : Yes or available.
- : No or not available.

- ① : DC rating available on request.
- ⑨ : For AC UVT, a UVT controller is mounted externally.
- ⑫ : Line side interpole barriers are supplied as standard.
- ⑯ : Available on request, contact Terasaki for details.
- ㉚ : Draw-out leads, horizontally.
- ㉛ : Draw-out leads, vertically.
- ㉜ : Not applicable to IT systems at voltage shown.

2

Ratings and Specifications

TemBreak

Standard Series

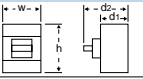
Ampere Frame	630		630		800		800		**1250		1600		2000		2500	
Type	XS630SE-C		XS630SE		XS800NJ		XS800SE		XS1250SE		XS1600SE		XS2000NE		XS2500NE	
Number of poles	3 4		3 4		3 4		3 4		3 4		3 4		3 4		3 4	
RATED CURRENT (A) [In]	NRC ASR		NRC ASR		NRC ASR		NRC ASR		NRC ASR		NRC ASR		NRC ASR		NRC ASR	
Calibrated at 45°C as standard, 50°C on request.	min. max.		min. max.		min. max.		min. max.		min. max.		min. max.		min. max.		min. max.	
	630 315 630		630 315 630		800 500 800		800 400 800		1000 500 1000 1250 630 1250		1600 800 1600		2000 1000 2000		2500 1250 2500	
RATED IMPULSE WITHSTAND VOLTAGE Uimp [kV]	8		8		8		8		8		8		8		8	
AC RATED INSULATION VOLTAGE [U_i]	690		690		690		690		690		690		690		690	
AC RATED BREAKING CAPACITY sym. r.m.s. [kA]																
IEC 947-2 [Icu]	690V 16/8 ②		20/10 ②		20/10 ②		20/10 ②		25/19 ②		35/35 ②		45/42 ②		45/42 ②	
BS EN 60947-2 [Icu]	500V 25/13 ②		35/18 ②		35/18 ②		35/18 ②		45/34 ②		65/49 ②		65/49 ②		65/49 ②	
CEI EN 60947-2 [Icu]	440V 30/15		50/25		50/25		50/25		65/49		85/64		85/64		85/64	
IEC 947-2 [Ics]	415V 35/18		50/25		50/25		50/25		65/49		85/64		85/64		85/64	
BS EN 60947-2 [Ics]	400V 40/20		50/25		65/33		50/25		85/64		100/75		100/75		100/75	
CEI EN 60947-2 [Ics]	380V 40/20		50/25		65/33		50/25		85/64		100/75		100/75		100/75	
	240V 50/25		85/43		85/43		85/43		100/75		125/94		125/94		125/94	
NEMA AB-1	600V 25		30		30		30		42		65		65		65	
	480V 35		50		50		50		65		85		85		85	
	240V 50		85		85		85		85		125		125		125	
Without Inst.	240-690V 10		10		-		10		15		20		42		42	
DC RATED BREAKING CAPACITY [kA] ①	125V		-		-		-		-		-		-		-	
RATED SHORT TIME CURRENT r.m.s. [kA] [Icw]	10 (0.3 sec)		10 (0.3 sec)		-		10 (0.3 sec)		15 (0.3 sec)		20 (0.3 sec)		42 (0.3 sec)		42 (0.3 sec)	
UTILIZATION CATEGORY	B		B		A		B		B		B		B		B	
OUTLINE DIMENSIONS (mm)																
	w		210 280		210 280		210 280		210 280		210 280		320 429		320 429	
	h		273		273		273		370		370		450		450	
	d1		103		103		103		120		140		185		185	
	d2		145		145		145		171		191		245		245	
Weight (kg) ③ marked standard type	9.6 12.0		9.6 12.0		9.4 12.2		9.7 12.5		22.0 28.0		27.0 35.0		54.0 67.0		62.5 78.2	
CONNECTIONS AND MOUNTINGS																
Front connected (FC)	Terminal screw (FCS)		-		-		-		-		-		-		-	
	Attached flat bar (BAR)		○		○		○		○		○		○		-	
	Solderless terminal (PWC)		○		○		○		-		-		-		-	
Rear connected (RC)	Bolt stud (REB)		-		-		-		-		-		-		-	
	Flat bar stud (REF)		○		○		○		○		○		○		○	
Plug-in (PM)	For switchboard (PRC/PMB)		○		○		○		○		-		-		-	
	For distribution board		-		-		-		-		-		-		-	
Draw-out (DO)	○ ⑩		○ ⑩		○ ⑩		○ ⑩		○ ⑩		○		○		-	
STANDARD FEATURES																
ON-OFF colour indication	•		•		•		•		•		•		•		•	
Trip button	•		•		•		•		•		•		•		•	
PROTECTIVE FUNCTIONS																
Electronic type																
Adjustable LTD, STD & INST.	•		•		-		•		•		•		•		•	
Adjustable GFT or Adjustable PTA (option)	•		•		-		•		•		•		•		•	
Trip Indicators (option)	• ⑩		• ⑩		-		• ⑩		•		•		•		•	
Thermal-magnetic type																
Thermal and fixed magnetic trips	-		-		-		-		-		-		-		-	
Thermal and adjustable magnetic trips	-		-		-		-		-		-		-		-	
Adjustable thermal and fixed magnetic trips	-		-		-		-		-		-		-		-	
Adjustable thermal and magnetic trips	-		-		-		-		-		-		-		-	
ACCESSORIES (option)																
Internally mounted	Auxiliary switch		AX,AXE •(AX)		•(AX)		•(AX)		•(AX)		•(AX)		•(AX)		•(AX)	
	Alarm switch		AL,ALE •(AL)		•(AL)		•(AL)		•(AL)		•(AL)		•(AL)		•(AL)	
	Shunt trip		SHT •		•		•		•		•		•		•	
	Undervoltage trip ⑨		UVT •		•		•		•		•		•		•	
Externally mounted	Motor operator		MOT •		•		•		•		•		•		•	
	Handle Panel mounted type		OHE •		•		•		•		•		•		•	
	operating Breaker mounted type		OHJ •		•		•		•		•		•		•	
	mechanism Variable depth type		OHH •		•		•		•		•		•		•	
	Handle extension		EHA •		•		•		• ⑩		• ⑩		• (supplied standard)		• (supplied standard)	
	Mechanical Front type		MIF •		•		•		•		•		•		•	
	interlock Rear type		MIB •		•		•		•		•		•		•	
	Handle holder		HH •		•		•		•		•		•		•	
	Handle lock		HL •		•		•		•		•		•		•	
	Terminal Front conn. type		TCF •		•		•		•		•		•		•	
	cover Rear conn./ plug-in type		TCR •		•		•		•		•		•		•	
	Interpole barrier		TBA •		•		•		•		•		•		•	
	Accessory lead terminal		② LTF •		•		•		•		•		•		•	
			② LTS •		-		-		-		-		-		-	
	Door flange		D.F •		•		•		•		•		•		•	
	IP20 Protection (Plug-in type)		IP20 •		•		•		•		•		•		•	

Notes:

- ** : XS1250SE, 400A and 800A CT's available, only in a fixed high Inst. setting. (refer to page 24 for details).
- NRC : Nominal Rated Current.
- ASR : Adjustable Setting Range.
- : Standard. This configuration is used unless otherwise specified.
- ① : Optional. Specify when ordering.
- : Yes or available.

- : No or not available.
- ① : DC rating available on request.
- ⑨ : For AC UVT, a UVT controller is mounted externally.
- ⑩ : One is supplied with every five breakers. Please specify if more are required.
- ⑩ : Available on request, contact Terasaki for details
- ② : Draw-out leads, horizontally.
- ③ : Draw-out leads, vertically.
- ④ : Not applicable to IT systems at voltage shown.

2

Ratings and Specifications TemBreak High Fault Level Series

Ampere Frame	125		160		250		250		400		630		800		800	
Type	XH125NJ		XH160NJ		XH250NJ		XH250PE		XH400SE		XH630SE		XH800SE		XH800PS	
Number of poles	3	4	3	4	3	4	3	4	3	4	3	4	3	4	3	4
RATED CURRENT (A) [In]	NRC ASR		NRC ASR		NRC ASR		NRC ASR		NRC ASR		NRC ASR		NRC ASR		NRC ASR	
Calibrated at 45°C as standard, 50°C on request.	min. max.		min. max.		min. max.		min. max.		min. max.		min. max.		min. max.		min. max.	
	20	12.5 20	160	100 160	160	100 160	250	125 250	250	125 250	630	315 630	800	400 800	800	700
	32	20 32														
	50	32 50														
	63	40 63														
	100	63 100														
	125	80 125														
RATED IMPULSE WITHSTAND VOLTAGE Uimp [kV]	8		8		8		8		8		8		8		8	
AC RATED INSULATION VOLTAGE [U]	690		690		690		690		690		690		690		690	
AC RATED BREAKING CAPACITY sym. r.m.s. [kA]																
IEC 947-2 [Icu]	690V 8/4 ②		15/7.5 ②		15/7.5 ②		20/10 ②		20/10 ②		20/10 ②		20/10 ②		45/23 ②	
BS EN 60947-2 [Icu]	500V 25/13 ②		25/13 ②		25/13 ②		42/21 ②		42/21 ②		42/21 ②		42/21 ②		65/33 ②	
CEI EN 60947-2 [Icu]	440V 42/21		42/21		42/21		65/33		65/33		65/33		65/33		85/43	
	415V 50/25		50/25		50/25		65/33		65/33		65/33		65/33		85/43	
	400V 50/25		50/25		50/25		65/33		65/33		65/33		65/33		100/50	
	380V 50/25		50/25		50/25		65/33		65/33		65/33		65/33		100/50	
	240V 85/43		85/43		85/43		100/50		100/50		100/50		100/50		125/63	
NEMA AB-1	600V 25		25		25		42		42		42		42		65	
	480V 42		42		42		65		65		65		65		85	
	240V 85		85		85		85		85		85		85		125	
Without Inst.	240-690V		-		-		5		5		10		10		-	
DC RATED BREAKING CAPACITY [kA]	250V 40		40		40		-		-		-		-		50	
	125V 40		40		40		-		-		-		-		50	
RATED SHORT TIME CURRENT r.m.s. [kA] [Icw]	-		-		-		5 (0.3 sec)		5 (0.3 sec)		10 (0.3 sec)		10 (0.3 sec)		-	
UTILIZATION CATEGORY	A		A		A		B		B		B		B		A	
OUTLINE DIMENSIONS (mm)																
	w	90 120	105 140	105 140	140 185	140 185	210 280	210 280	210 280	210 280	210 280	210 280	210 280	210 280	210 280	210 280
	h	155	165	165	260	260	273	273	273	273	273	273	273	273	273	273
	d1	86	103	103	103	103	103	103	103	103	103	103	103	103	103	103
	d2	104	124	124	145	145	145	145	145	145	145	145	145	145	145	145
Weight (kg) ① marked standard type	1.3 1.58		2.1 2.6		2.1 2.6		4.8 6.2		4.8 6.2		9.6 12.0		9.7 12.5		9.4 12.2	
CONNECTIONS AND MOUNTINGS																
Front connected (FC)	Terminal screw (FCS)		①		①		①		①		①		①		①	
	Attached flat bar (BAR)		-		① (BAR)		① (BAR)		① (BAR)		① (BAR)		① (BAR)		① (BAR)	
	Solderless terminal (PWC)		①		①		①		①		①		①		①	
Rear connected (RC)	Bolt stud (REB)		①		-		-		-		-		-		-	
	Flat bar stud (REF)		-		①		①		①		①		①		①	
Plug-in (PM)	For switchboard (PRC/PMB)		①		①		①		①		①		①		①	
	For distribution board		①		-		-		-		-		-		-	
Draw-out (DO)	-		① ⑩		① ⑩		① ⑩		① ⑩		① ⑩		① ⑩		① ⑩	
STANDARD FEATURES																
ON-OFF colour indication	•		•		•		•		•		•		•		•	
Trip button	•		•		•		•		•		•		•		•	
PROTECTIVE FUNCTIONS																
Electronic type	-		-		-		•		•		•		•		•	
Adjustable LTD, STD & INST.	-		-		-		•		•		•		•		•	
Adjustable GFT or Adjustable PTA (option)	-		-		-		• (PTA only)		• (PTA only)		•		•		•	
Trip Indicators (option)	-		-		-		• ⑩		• ⑩		• ⑩		• ⑩		• ⑩	
Thermal-magnetic type	-		-		-		-		-		-		-		-	
Thermal and fixed magnetic trips	-		-		-		-		-		-		-		-	
Thermal and adjustable magnetic trips	-		-		-		-		-		-		-		-	
Adjustable thermal and fixed magnetic trips	•		•		•		-		-		-		-		-	
Adjustable thermal and magnetic trips	-		-		-		-		-		-		-		-	
ACCESSORIES (option)	CODE															
Internally mounted	Auxiliary switch AX,AXE		•(AXE)		•(AXE)		•(AX)		•(AX)		•(AX)		•(AX)		•(AX)	
	Alarm switch AL,ALE		•(ALE)		•(ALE)		•(AL)		•(AL)		•(AL)		•(AL)		•(AL)	
	Shunt trip SHT		•		•		•		•		•		•		•	
	Undervoltage trip ② UVT		•		•		•		•		•		•		•	
Externally mounted	Motor operator MOT		•		•		•		•		•		•		•	
	Handle operating mechanism Panel mounted type OHE		•		•		•		•		•		•		•	
	Breaker mounted type OHJ		•		•		•		•		•		•		•	
	Variable depth type OHH		•		•		•		•		•		•		•	
	Handle extension EHA		-		-		-		-		-		-		-	
	Mechanical interlock Front type MIF		•		•		•		•		•		•		•	
	Rear type MIB		•		•		•		•		•		•		•	
	Handle holder HH		•		•		•		•		•		•		•	
	Handle lock HL		•		•		•		•		•		•		•	
	Terminal cover Front conn. type TCF		•		•		•		•		•		•		•	
	Rear conn./ plug-in type TCR		•		•		•		•		•		•		•	
	Interpole barrier TBA		• ⑫		• ⑫		• ⑫		• ⑫		• ⑫		• ⑫		• ⑫	
	Accessory lead terminal ⑫ LTF		-		-		-		-		-		-		-	
	⑫ LTS		•		•		•		•		•		•		•	
	Door flange D.F		•		•		•		•		•		•		•	
	IP20 Protection (Plug-in type) IP20		•		•		•		•		•		•		•	

Notes:

NRC : Nominal Rated Current

ASR : Adjustable Setting Range

① : Standard. This configuration is used unless otherwise specified.

② : Optional. Specify when ordering.

• : Yes or available.

- : No or not available.

① : DC rating available on request.

② : For AC UVT, a UVT controller is mounted externally.

⑫ : Line side interpole barriers are supplied as standard.

⑩ : Available on request, contact Terasaki for details.

⑫ : Draw-out leads, horizontally.

⑬ : Draw-out leads, vertically.

⑭ : Not applicable to IT systems at voltage shown.

2

Ratings and Specifications

TemBreak

Switch Disconnecter Series

Rated Current (A)	125		160		250		400		630		800		1250		1600	
Type	XS125NN		XS160NN		XS250NN		XS400NN		XS630NN		XS800NN		XS1250NN		XS1600NN	
Number of poles	3	4	3	4	3	4	3	4	3	4	3	4	3	4	3	4
RATING																
Rated operational voltage (V)	AC 690		690		690		690		690		690		690		690	
IEC 947-3, EN 60947-3	DC 250		250		250		250		250		250		250		250	
RATED SHORT CIRCUIT MAKING CAPACITY	peak/kA 2.5		6		6		9		15		15		32		45	
RATED SHORT TIME CURRENT r.m.s./kA	1 sec (*0.3s) 1.8		4		4		5*		9.6*		9.6*		15*		20*	
OUTLINE DIMENSIONS (mm)																
	90 120		105 140		105 140		140 185		210 280		210 280		210 280		210 280	
	155		165		165		260		273		273		370		370	
	86		86		86		103		103		103		120		140	
	104		107		107		145		145		145		171		191	
	1.1 1.4		1.85 2.4		1.85 2.4		4.7 6.1		9.0 11.5		9.4 12.2		20.4 26.4		24.9 32.9	
Weight (kg) ☉ Marked standard type																
CONNECTIONS AND MOUNTINGS																
Front connected (FC)	Terminal screw (FCS) ☉		☉		☉		☉		-		-		-		-	
	Attached flat bar (BAR) -		☉ (BAR)		☉ (BAR)		☉ (BAR)		☉		☉		☉		☉	
	Solderless terminal (PWC) ☉		☉		☉		☉		☉		☉		☉		☉	
Rear connected (RC)	Bolt stud (REB) ☉		-		-		-		-		-		-		-	
	Flat bar stud (REF) -		-		-		-		-		-		-		-	
Plug-in (PM)	For switchboard (PRC/PMB) ☉		☉		☉		☉		☉		☉		☉		-	
	For distribution board -		-		-		-		-		-		-		-	
Draw-out (DO)	-		-		-		☉ ⑩		☉ ⑩		☉ ⑩		☉ ⑩		☉	
STANDARD FEATURES																
ON-OFF colour indication	•		•		•		•		•		•		•		•	
Trip button	•		•		•		•		•		•		•		•	
ACCESSORIES (option) CODE																
Internally mounted	Auxiliary switch	AX,AXE	*(AXE)		*(AXE)		*(AXE)		*(AX)		*(AX)		*(AX)		*(AX)	
	Alarm switch	AL,ALE	*(ALE)		*(ALE)		*(ALE)		*(AL)		*(AL)		*(AL)		*(AL)	
	Shunt trip	SHT	•		•		•		•		•		•		•	
	Undervoltage trip ☉	UVT	•		•		•		•		•		•		•	
Externally mounted	Motor operator	MOT	-		•		•		•		•		•		•	
	External operating handle	Panel mounted type OHE	•		•		•		•		•		•		•	
		Breaker mounted type OHJ	-		•		•		•		•		•		•	
		Variable depth type OHH	-		•		•		•		•		•		•	
	Extension handle	EHA	-		-		-		•		•		• ⑩		• ⑩	
	Mechanical interlock	Front type MIF	-		•		•		•		•		•		•	
		Rear type MIB	-		•		•		•		•		•		•	
	Handle holder	HH	•		•		•		•		•		•		•	
	Handle lock	HL	•		•		•		•		•		•		•	
	Terminal cover	Front conn. type TCF	•		•		•		•		•		•		-	
		Rear conn. / plug-in type TCR	•		•		•		•		•		•		-	
	Interpole barrier	TBA	• ⑫		• ⑫		• ⑫		• ⑫		•		•		•	
	Accessory lead terminal	⑫ LTF	-		-		-		•		•		•		•	
		⑬ LTS	•		•		•		-		-		-		-	
	Door flange	D.F	•		•		•		•		•		•		•	
	IP20 Protection (Plug-in type)	IP20	•		•		•		•		•		•		•	
Maximum Switching Current [A]	AC	750	960		1500		2400		3780		4800		7500		9600	
	DC	313	400		625		1000		1575		2000		3125		4000	
Utilization Category	AC-23A	AC-23A	AC-23A		AC-23A		AC-23A		AC-23A		AC-23A		AC-23A		AC-23A	
Endurance: Number of operations without current		7000	7000		7000		4000		4000		2500		2500		2500	
Number of operations with current		1000	1000		1000		1000		1000		500		500		500	

Notes:

- ☉ : Standard. This configuration is used unless otherwise specified.
- : Optional. Specify when ordering.
- : Yes or available.
- : No or not available.
- ⑩ : Comes with conductor pressing terminal.
- ⑪ : For AC UVT, a UVT Controller is mounted externally.
- ⑫ : Line side interpole barriers are supplied as standard.
- ⑬ : Draw-out leads, horizontally.
- ⑭ : Draw-out leads, vertically.

2

Ratings and Specifications

TemBreak

Switch Disconnecter Series

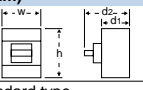
Rated Current (A)	2000		2500							
Type	XS2000NN		XS2500NN							
Number of poles	3	4	3	4						
RATING										
Rated operational voltage (V)	AC 690		690							
IEC 947-3, EN 60947-3	DC 250		250							
RATED SHORT CIRCUIT MAKING CAPACITY	peak/kA 90		90							
RATED SHORT TIME CURRENT r.m.s./kA	1 sec (*0.3s) 33*		33*							
OUTLINE DIMENSIONS (mm)										
	w	320	429	320	429					
	h	450		450						
	d1	185		185						
	d2	245		245						
Weight (kg) Ⓞ Marked standard type	51.8	64.8	60	75.7						
CONNECTIONS AND MOUNTINGS										
Front connected (FC)	Terminal screw (FCS)	-		-						
	Attached flat bar (BAR)	○		-						
	Solderless terminal (PWC)	-		-						
Rear connected (RC)	Bolt stud (REB)	-		-						
	Flat bar stud (REF)	○		○						
Plug-in (PM)	For switchboard (PRC/PMB)	-		-						
	For distribution board	-		-						
Draw-out (DO)		○		-						
STANDARD FEATURES										
ON-OFF colour indication		•		•						
Trip button		•		•						
ACCESSORIES (option) CODE										
Internally mounted	Auxiliary switch	AX, AXE	•(AX)	•(AX)						
	Alarm switch	AL, ALE	•(AL)	•(AL)						
	Shunt trip	SHT	•	•						
	Undervoltage trip Ⓣ	UVT	•	•						
Externally mounted	Motor operator	MOT	•	•						
	External operating handle	Panel mounted type OHE	•	•						
		Breaker mounted type OHJ	-	-						
		Variable depth type OHH	-	-						
	Extension handle	EHA	○	○						
	Mechanical interlock	Front type MIF	•	•						
		Rear type MIB	•	•						
	Handle holder	HH	•	•						
	Handle lock	HL	•	•						
	Terminal cover	Front conn. type TCF	-	-						
		Rear conn. / plug-in type TCR	-	-						
	Interpole barrier	TBA	-	-						
	Accessory lead terminal	Ⓣ LTF	•	•						
		Ⓣ LTS	-	-						
	Door flange	D.F	•	•						
	IP20 Protection (Plug-in type)	IP20	-	-						
Maximum Switching Current [A]	AC	12000	15000							
	DC	5000	6250							
Utilization Category		AC-23A	AC-23A							
Endurance: Number of operations without current		2500	2500							
Number of operations with current		500	500							

Notes:

- Ⓣ : Standard. This configuration is used unless otherwise specified.
- : Optional. Specify when ordering.
- : Yes or available.
- : No or not available.
- Ⓣ : For AC UVT, a UVT Controller is mounted externally.
- Ⓣ : Draw-out leads, horizontally.
- Ⓣ : Draw-out leads, vertically.

2

Ratings and Specifications

TemBreak

Mining Series (1100V)

Ampere Frame	400	630	800	1250				
Type	XV400NE	XV630NE	XV800NE	XV1250NE				
Number of poles	3	3	3	3				
RATED CURRENT (A). In	NRC ASR	NRC ASR	NRC ASR	NRC ASR				
Calibrated at 45°C as standard, 50°C on request.	min.max. 250 125 250 400 200 400	min.max. 630 315 630	min.max. 800 400 800	min.max. 1000 500 1000 1250 630 1250				
AC RATED INSULATION VOLTAGE [U_i]	1100	1100	1100	1100				
AC RATED BREAKING CAPACITY sym. r.m.s. [kA]								
Cos φ = 0.3	1100V 900V	12.5	12.5	12.5	20			
OUTLINE DIMENSIONS (mm)								
								
	w	140	210	210	210			
	h	260	273	273	370			
	d1	103	103	103	120			
	d2	145	145	145	171			
Weight (kg) ⊖ marked standard type	4.8	9.6	9.7	22				
CONNECTIONS AND MOUNTINGS								
Front	Terminal screw (FCS)	⊖	–	–	–			
connected (FC)	Attached flat bar (BAR)	⊖ (BAR)	⊖	⊖	⊖			
	Solderless terminal (PWC)	–	–	–	–			
Rear	Bolt stud (REB)	–	–	–	–			
connected (RC)	Flat bar stud (REF)	⊖	⊖	⊖	⊖			
Plug-in (PM)	For switchboard (PRC/PMB)	⊖	⊖	⊖	⊖			
	For distribution board	–	–	–	–			
Draw-out (DO)	–	–	–	–				
STANDARD FEATURES								
ON-OFF colour indication	•	•	•	•				
Trip button	•	•	•	•				
PROTECTIVE FUNCTIONS								
Electronic type								
Adjustable LTD, STD & INST.	•	•	•	•				
Adjustable GFT or Adjustable PTA (option)	• (PTA only)	•	•	•				
Trip Indicators (option)	• ⑩	• ⑩	• ⑩	•				
Thermal-magnetic type								
Thermal and fixed magnetic trips	–	–	–	–				
Thermal and adjustable magnetic trips	–	–	–	–				
Adjustable thermal and fixed magnetic trips	–	–	–	–				
Adjustable thermal and magnetic trips	–	–	–	–				
ACCESSORIES (option) CODE								
Internally mounted	Auxiliary switch AX, AXE	•(AX)	•(AX)	•(AX)	•(AX)			
	Alarm switch AL, ALE	•(AL)	•(AL)	•(AL)	•(AL)			
	Shunt trip SHT	•	•	•	•			
	Undervoltage trip UVT	• ⑨	• ⑨	• ⑨	• ⑨			
Externally mounted	Motor operator MOT	•	•	•	•			
	Handle Panel mounted type OHE	•	•	•	•			
	operating Breaker mounted type OHJ	•	•	•	•			
	mechanism Variable depth type OHH	•	•	•	•			
	Handle extension EHA	–	–	–	• ⑩			
	Mechanical Front type MIF	•	•	•	•			
	interlock Rear type MIB	•	•	•	•			
	Handle holder HH	•	•	•	•			
	Handle lock HL	•	•	•	•			
	Terminal Front conn. type TCF	•	•	•	•			
	cover Rear conn. / plug-in type TCR	•	•	•	•			
	Interpole barrier TBA	•	•	•	•			
	Accessory lead terminal ② LTF	•	•	•	•			
	② LTS	–	–	–	–			
	Door flange D.F	•	•	•	•			
	IP20 Protection (Plug-in type) IP20	•	•	•	•			

Notes:

- NRC : Nominal Rated Current
- ASR : Adjustable Setting Range
- ⊖ : Standard. This configuration is used unless otherwise specified.
- : Optional. Specify when ordering.
- : Yes or available.
- : No or not available.
- ⑨ : For AC UVT, a UVT Controller is mounted externally.

- ⑩ : One is supplied with every five breakers. Please specify if more are required.
- ⑫ : Line side interpole barriers are supplied as standard.
- ⑬ : Available on request, contact Terasaki for details.
- ⑭ : Draw-out leads, horizontally.
- ⑮ : Draw-out leads, vertically.

2

Ratings and Specifications

TemBreak

D.C. Application Series

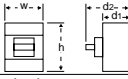
Ampere Frame	1000		1250		1600		2000		2500				
Type	XS1000ND		XS1250ND		XS1600ND		XS2000ND		XS2500ND				
Number of poles	2 3		2 3		2 3		2 3		2 3				
RATED CURRENT (A). [In]													
	1000		1250		1600		2000		2500				
DC RATED OPERATIONAL VOLTAGE (Ue) [VDC]	250	600	250	600	250	600	250	600	250	600			
DC RATED INSULATION VOLTAGE (Ui) [VDC]	600		600		600		600		600				
DC RATED BREAKING CAPACITY [kA]													
IEC 947-2 [Icu]	-		-		-		-		-				
BS EN 60947-2 [Icu]	-		-		-		-		-				
CEI EN 60947-2 [Icu]	-		-		-		-		-				
IEC 947-2 [Ics]	Ⓢ 600V	20/10	-	20/15	-	20/15	-	20/15	-	20/15			
BS EN 60947-2 [Ics]	Ⓢ 500V	20/10	-	20/15	-	20/15	-	20/15	-	20/15			
CEI EN 60947-2 [Ics]	Ⓢ 350V	30/15	-	30/23	-	30/23	-	30/23	-	30/23			
	250V	50/20	-	50/30	-	50/30	-	50/30	-	50/30			
OUTLINE DIMENSIONS (mm)													
	w	210	210	210	320	320	320	320	320	320			
	h	273	370	370	450	450	450	450	450	450			
	d1	103	140	140	185	185	185	185	185	185			
	d2	145	191	191	245	245	245	245	245	245			
Weight (kg) Ⓞ marked standard type	9.2 10.3		23.8 26.0		24.0 27.0		50.0 54.0		55.7 62.5				
CONNECTIONS AND MOUNTINGS													
Front connected (FC)	Terminal screw (FCS)	-	-	-	-	-	-	-	-	-			
	Attached flat bar (BAR)	Ⓞ	Ⓞ	Ⓞ	Ⓞ	Ⓞ	Ⓞ	Ⓞ	Ⓞ	Ⓞ			
	Solderless terminal (PWC)	-	-	-	-	-	-	-	-	-			
Rear connected (RC)	Bolt stud (REB)	-	-	-	-	-	-	-	-	-			
	Flat bar stud (REF)	Ⓞ	Ⓞ	Ⓞ	Ⓞ	Ⓞ	Ⓞ	Ⓞ	Ⓞ	Ⓞ			
Plug-in (PM)	For switchboard (PRC/PMB)	-	-	-	-	-	-	-	-	-			
	For distribution board	-	-	-	-	-	-	-	-	-			
Draw-out (DO)		-	-	Ⓞ	Ⓞ	Ⓞ	Ⓞ	Ⓞ	Ⓞ	Ⓞ			
STANDARD FEATURES													
ON-OFF colour indication		•	•	•	•	•	•	•	•	•			
Trip button		•	•	•	•	•	•	•	•	•			
PROTECTIVE FUNCTIONS													
Thermal and adjustable magnetic trips		•	•	•	•	•	•	•	•	•			
Adjustable magnetic trips only		•	•	•	•	•	•	•	•	•			
ACCESSORIES (option) CODE													
Internally mounted	Auxiliary switch	AX, AXE	•(AX)	•(AX)	•(AX)	•(AX)	•(AX)	•(AX)	•(AX)	•(AX)			
	Alarm switch	AL, ALE	•(AL)	•(AL)	•(AL)	•(AL)	•(AL)	•(AL)	•(AL)	•(AL)			
	Shunt trip	SHT	•	•	•	•	•	•	•	•			
	Undervoltage trip	UVT	•	•	•	•	•	•	•	•			
Externally mounted	Motor operator	MOT	•	•	•	•	•	•	•	•			
	Handle operating mechanism	Panel mounted type OHE	•	•	•	•	•	•	•	•			
		Breaker mounted type OHJ	•	•	•	•	•	•	•	•			
		Variable depth type OHH	•	•	•	•	•	•	•	•			
	Handle extension	EHA	•	• [Ⓣ]	• [Ⓣ]	• [Ⓣ]	• [Ⓣ]	• [Ⓣ]	• [Ⓣ]	• [Ⓣ]			
	Mechanical interlock	Front type MIF	•	•	•	•	•	•	•	•			
		Rear type MIB	•	•	•	•	•	•	•	•			
	Handle holder	HH	•	•	•	•	•	•	•	•			
	Handle lock	HL	•	•	•	•	•	•	•	•			
	Terminal cover	Front conn. type TCF	•	•	•	•	•	•	•	•			
		Rear conn./ plug-in type TCR	•	•	•	•	•	•	•	•			
	Interpole barrier	TBA	•	•	•	•	•	•	•	•			
	Accessory lead terminal	Ⓣ ² LTF	•	•	•	•	•	•	•	•			
		Ⓣ ³ LTS	•	•	•	•	•	•	•	•			
	Door flange	D.F	•	•	•	•	•	•	•	•			
	IP20 Protection (Draw-out type)	IP20	-	-	•	•	•	•	•	•			

Notes:

- NRC : Nominal Rated Current.
- ASR : Adjustable Setting Range.
- Ⓞ : Standard. This configuration is used unless otherwise specified.
- Ⓣ : Optional. Specify when ordering.
- : Yes or available.

- : No or not available.
- Ⓣ¹ : One supplied with every five breakers.
- Ⓣ² : The time constant (L/R) of the circuit should be less than 2.0ms at or below rated current, less than 7ms for short circuit equal and below 10kA, less than 15ms for short circuit over 10kA and the connection should be three poles in series, as shown on page 31.
- Ⓣ³ : Draw-out leads, horizontally.
- Ⓣ³ : Draw-out leads, vertically.

Accessory and mounting details for D.C. Application Series are identical to those for the same frame size Standard Series (i.e. for XS1000ND refer to XS800NJ, XS1250ND and XS1600ND refer to XS1600NE, XS2000ND and XS2500ND refer to XS2500NE).

Note: All TemBreak Thermal Magnetic MCCBs can be used up to 250V DC, For higher DC voltages please refer to page 35.

2

Ratings and Specifications

TemBreak

Motor Protection Series

Ampere Frame			30						
Type			XM30PB						
Number of poles			3						
RATINGS									
Motor Voltage (VAC)			200-220V	400-440V					
			(A)	(A)					
Motor Output (kW)	(kW)								
and	0.1								
Rated Current (A)	0.2	1.4	0.7						
Calibrated at 45°C for Industrial use	0.4	2.6	1.4						
50°C for Marine use	0.75	4	2.0						
	1.5	8	4						
	2.2	10	5						
	3.7		8						
	5.5		12						
	7.5								
	11								
	15								
	18.5								
	22								
	30								
	37								
	45								
	55								
AC RATED BREAKING CAPACITY (kA)									
JIS C 8370	460V		85						
(sym.)	220V		125						
IEC 947-2	415V	Icu/Ics	85/85						
BSEN60947-2	380V		85/85						
	240V		125/125						
NEMA AB-1	480V		-						
	240V		125						
Weight (kg)	marked standard type		1.78						
CONNECTIONS AND MOUNTINGS									
Front	Terminal screw (FCS)		⊙ ⊚						
connected (FC)	Attached flat bar (BAR)		-						
	Solderless terminal (PWC)		○						
Rear connected (RC)			○ (bolt stud)						
Plug-in (PM)			○ (sw. board)						
STANDARD FEATURES									
ON-OFF colour indication			•						
Trip button			•						
Overcurrent trip type			Hyd. magnetic						
ACCESSORIES (option)			CODE						
Externally	Motor operator		MOT	-					
mounted	Handle	Panel mounted type	OHE	•					
	operating	Breaker mounted type	OHJ	•					
	mechanism	Variable depth type	OHH	•					
	Handle extension		EHA	-					
	Mechanical	Front type	MIF	•					
	interlock	Rear type	MIB	-					
	Handle holder		HH	•					
	Handle lock		HL	•					
	Terminal	Front conn. type	TCF	-					
	cover	Rear conn./ plug-in type	TCR	-					
	Interpole barrier		TBA	-					
	Accessory lead terminal		LTS	•					
	Door flange		D,F	•					

Notes:

- ⊙ : Standard. This configuration is used unless otherwise specified.
- : Optional standard. Specify when ordering.
- : Yes or available.
- : No or not available.
- ⊚ : Comes with conductor pressing terminals

2

Ratings and Specifications

TemBreak

TemProtect (ELR) and Earth Leakage Block (ELB)

TemProtect Earth Leakage Relays (ELR)

Type	ELRC-1	ELR-1	ELRm-1	ELR-2S	ELRm-2S	ELR-3C	ELR-4	ELRm-4
Integral Current Transformer	YES (1)	NO	NO	NO	NO	NO	NO	NO
RATINGS								
Voltage 24-48 VA.C/D.C.	•	•	•	•	•	•	•	•
110V D.C.	•	•	•	•	•	•	•	•
110/240/415 V A.C.	•	•	•	•	•	•	•	•
SENSITIVITY CURRENT								
25mA to 25A	•	•	•	•	•	•	•	•
250mA to 250A	○	○	○	○	○	○	○	○
30mA to 2.5A	-	-	-	-	-	-	-	-
300mA to 25A	-	-	-	-	-	-	-	-
Time Delay 20msec to 5sec	•	•	•	•	•	•	•	•
20msec to 500msec	-	-	-	-	-	-	-	-
MOUNTINGS								
Panel Mounting	-	•	•	•	•	-	•	•
Din Rail Mounting	-	-	-	-	-	•	-	-
Base Mounting	•	-	-	-	-	-	-	-
FEATURES								
Mechanical Indication	-	-	•	-	•	-	-	•
Alarm at 70% ΔIn	-	-	-	•	•	-	-	-
Horizontal Case Option	-	-	-	-	-	-	-	-
Vertical Case Option	-	-	-	-	-	-	•	•
Fail Safe	-	-	-	-	-	-	-	-
OUTPUT CONTACTS								
1 C/O Trip Contact	-	-	-	•	•	•	-	-
2 C/O Trip Contacts	•	•	•	•	•	•	-	-
1 C/O Alarm Contact	-	-	-	•	•	•	-	-
Rating: 5A-250 Volt	•	•	•	•	•	•	•	•

Type	ELR-51	ELRm-51	ELR-52	ELRm-52	ELR-61	ELRm-61	ELR-62	ELRm-62
Integral Current Transformer	NO	NO	NO	NO	NO	NO	NO	NO
RATINGS								
Voltage 24-48 VA.C/D.C.	-	-	-	-	•	•	•	•
110V D.C.	-	-	-	-	•	•	•	•
110/240/415 V A.C.	•	•	•	•	•	•	•	•
SENSITIVITY CURRENT								
25mA to 25A	-	-	-	-	•	•	•	•
250mA to 250A	-	-	-	-	○	○	○	○
30mA to 2.5A	•	•	•	•	-	-	-	-
300mA to 25A	○	○	○	○	-	-	-	-
Time Delay 20msec to 5sec	-	-	-	-	•	•	•	•
20msec to 500msec	•	•	•	•	-	-	-	-
MOUNTINGS								
Panel Mounting	•	•	•	•	-	-	-	-
Din Rail Mounting	-	-	-	-	•	•	-	-
Base Mounting	-	-	-	-	-	-	-	-
FEATURES								
Mechanical Indication	-	-	-	•	-	•	-	•
Alarm at 70% ΔIn	-	-	-	•	-	•	-	•
Horizontal Case Option	-	-	-	-	-	-	-	-
Vertical Case Option	-	-	-	-	-	-	•	•
Fail Safe	•	•	•	•	-	-	-	-
OUTPUT CONTACTS								
1 C/O Trip Contact	-	-	•	•	-	-	•	•
2 C/O Trip Contacts	•	•	-	-	•	•	-	-
1 C/O Alarm Contact	-	-	-	-	•	•	-	-
Rating: 5A-250 Volt	•	•	•	•	•	•	•	•

Earth Leakage Blocks (ELB)

Type	ELB-S	ELB-A
Applicable breakers 125 AF	YES	YES
250 AF (2)	YES	YES
RATINGS		
Current sensitivity 0.03	○	○
IΔn (A) 0.1	○	○
(adjustable) 0.3	○	○
1.0	○	○
3.0	○	○
Operating voltage 200-440V AC	○	○
Operating frequency 50/60 Hz	○	○
FEATURES		
Visual trip indication	○	○
Push-Button test	○	○
Pick-Up LED	-	○
Pre-Trip alarm contact (3)	-	○
Trip/Non-Trip function (4)	-	○

Note: ELB units are factory fitted to the required MCCB. Please refer to page 54 for more details.

- : Standard. This configuration is used unless otherwise specified.
- : Optional. Specify when ordering.
- : Yes or available
- : No or not available.
- (1) : Internal Diameter 35mm, 60mm, 80mm or 110mm
- (2) : Excluding XH250PE
- (3) : Set at 50% or 70% IΔn by dip-switch
- (4) : Set by dip-switch

Current Transformers for the ELR Series

		Diameter (mm)
Current Transformer	CT-	35 - 60 - 80 - 110 - 210
Split Current Transformer	CTA -	110 - 210

Thermal Magnetic Characteristics and Adjustments

23-35

- Range 24
- Operation Settings 25
- Examples 26
- Time, Current and Temperature Curves 27-34
- Special Applications 35

3

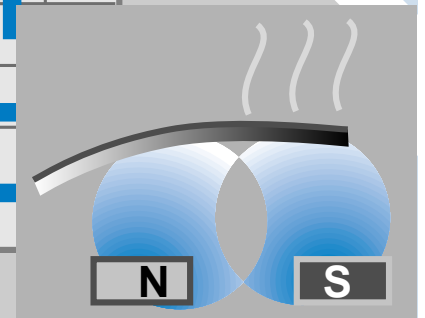

3

Thermal Magnetic Characteristics and Adjustments Range

Characteristics

TemBreak thermal magnetic MCCBs are available from 50AF to 800AF. Depending on the type of MCCB chosen the thermal and/or magnetic trip setting may be adjustable.

MCCB type	Fixed Thermal	Adjustable Thermal	Fixed Magnetic	Adjustable Magnetic
XS50NB, XE100NS	•	–	•	–
XS125CS, XS125NS	•	–	•	–
XS125CJ, XS125NJ, XH125NJ	–	•	•	–
XS160NJ, XH160NJ	–	•	•	–
XE225NS	•	–	•	–
XS250NJ, XS250PJ, XH250NJ	–	•	•	–
XE400NS	•	–	–	•
XS400CJ, XS400NJ	–	•	–	•
XE600NS	•	–	–	•
XS630CJ, XS630NJ	–	•	–	•
XH800PS	•	–	–	•
XS800NJ	–	•	–	•

- : Yes
- : No

Access to Setting Dials

From 125AF to 250AF the thermal adjustment is visible from the front of the MCCB. At 400AF and above a protective cover must be removed to gain access to the settings. To achieve access to the settings the cover screw under the 'sealed' label must be removed. To adjust the individual trip settings turn the setting dial with a flat bladed screwdriver. Once set secure the cover and apply a new sealing label. Access to setting dials can be restricted using optional lead sealing facility.



XS250NJ

Thermal adjustment setting dial.



XS400NJ

Sealed label
Spare sealing labels



XS400NJ (cover removed)

Thermal adjustment setting dial
Magnetic adjustment setting dial

Thermal adjustment dial blanking kits are available for 125 and 250A frame MCCBs

3

Thermal Magnetic Characteristics and Adjustments

Operation Settings

Thermal Adjustment

TemBreak MCCBs have a wide thermal adjustment range, one of the largest on the market. The rated current 'I_r' is continuously adjustable from 63% to 100% of its nominal current 'I_n'. There are three main points of calibration marked at 63%, 80% and 100%, as shown in the diagram below.

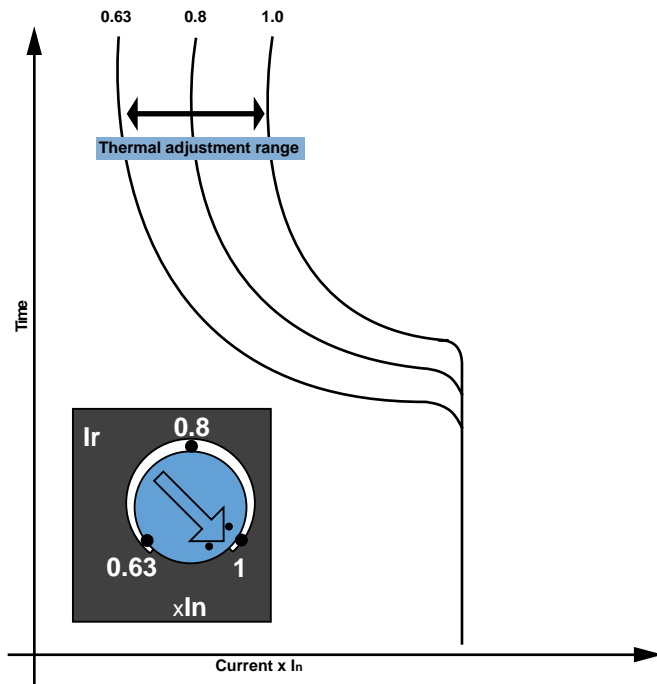

Magnetic Adjustment

Magnetic adjustment is available on MCCBs of 400AF and above. The magnetic setting 'I_m' is continuously adjustable from 500% to 1000% of its rated current 'I_n'. There are five main points of calibration marked as multiples of I_n; 5, 6, 7.1, 8.5 & 10. These are shown in the diagram below.

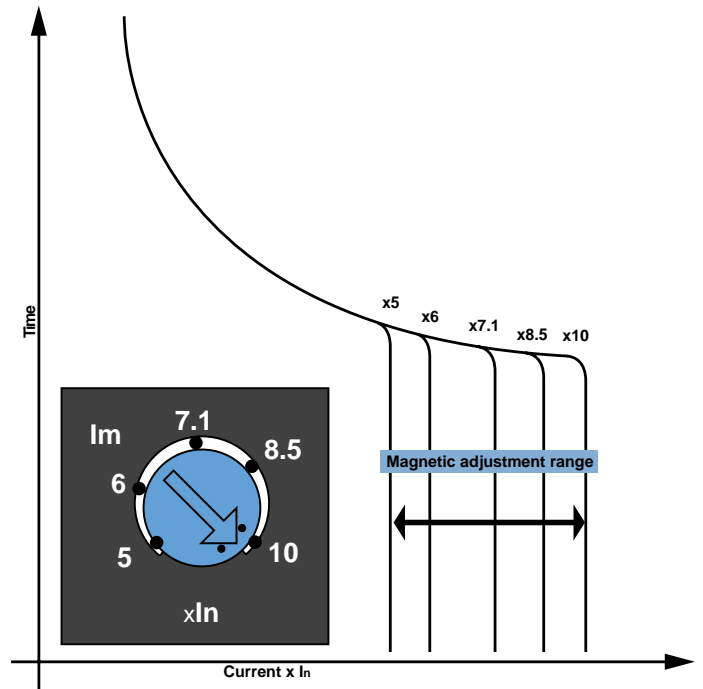

Examples

1. XS125NJ/125A MCCB set at I_r = 0.8, the rated current is calculated as 125 x 0.8 = 100A
2. XS400NJ/400A MCCB set at I_m = 6, the magnetic setting is calculated as 400 x 6 = 2400A
3. XS630NJ/630A MCCB set at I_r = 0.8 & I_m = 5.0
The rated current is calculated as 630 x 0.8 = 504A
The magnetic setting is calculated as 630 x 5 = 3150A

Note that the magnetic setting is a multiple of the nominal current I_n and not the rated current I_r.
All thermal and magnetic trip settings are expressed as AC r.m.s. values.
All MCCBs are calibrated at 45°C unless otherwise specified.

Breakers with adjustable magnetic trip

Breaker	Rated current (A)	Magnetic trip current (A)				
		Scale 10	8.5	7.1	6	5
XE400NS	250	2500	2125	1775	1500	1250
	300	3000	2550	2130	1800	1500
	350	3500	2975	2485	2100	1750
	400	4000	3400	2840	2400	2000
XS400CJ	250	2500	2125	1775	1500	1250
XS400NJ	400	4000	3400	2840	2400	2000
XE600NS	500	5000	4250	3550	3000	2500
	600	6000	5100	4260	3600	3000
XS630CJ	400	4000	3400	2840	2400	2000
XS630NJ	630	6300	5355	4473	3780	3150
XS800NJ	800	8000	6800	5680	4800	4000
XH800PS	700	7000	5950	4970	4200	8500
	800	8000	6800	5680	4800	4000

Note: The figures mentioned are standard values, if values other than those shown are required, please contact Terasaki.

Note: Setting; 3-poles can be adjusted simultaneously with one adjustment dial.

3

Thermal Magnetic Characteristics and Adjustments

Examples

Time/current characteristic curves

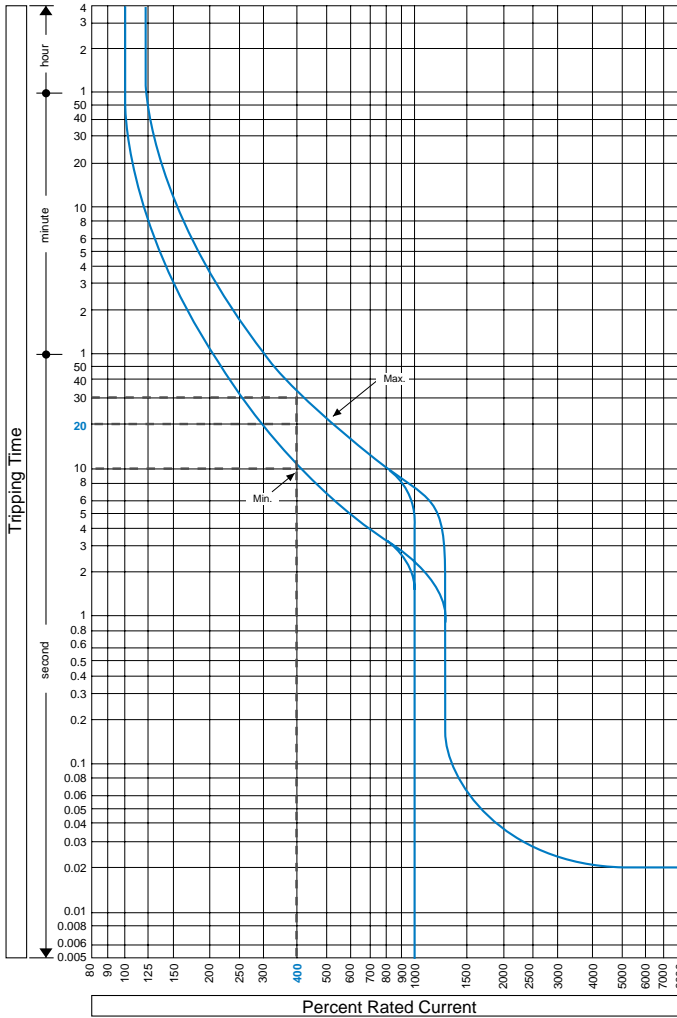

Example 1

The XS160NJ set at its maximum thermal setting of 160A experiences an overload of 640A.

What would be the tripping time?

Solution

As the axis are 'percent' rated current the overload as a percentage to rated current is

$$\frac{640}{160} = 400\%$$

The maximum and minimum on the curve are the tolerance bands. Therefore at 400% overload the tripping time would be as follows:

Max. trip time ≈ 30 seconds

Min. trip time ≈ 10 seconds

Average trip time ≈ 20 seconds

Due to strict quality control of the manufacturing and calibration processes, the characteristic curve of most MCCBs will follow the 'average' curve within the tolerance band.

Ambient compensating curves

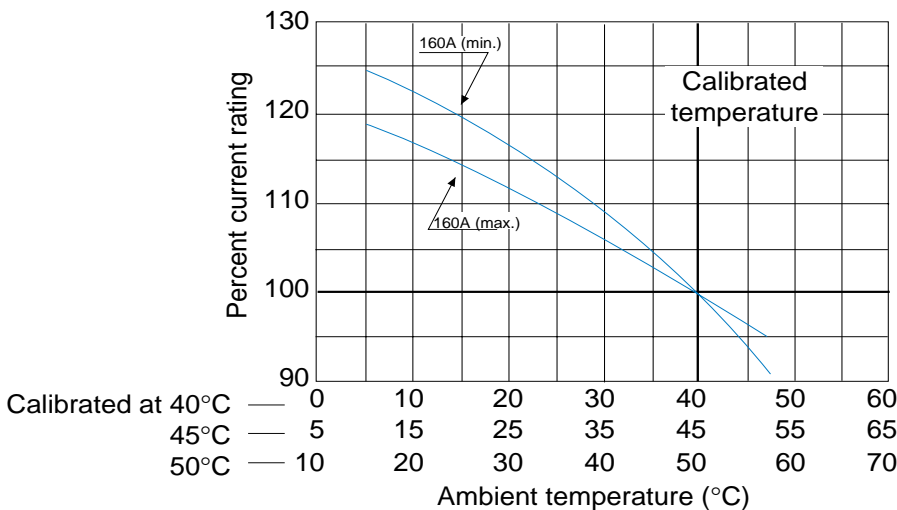

Example 2

The XS160NJ is calibrated at 160A for 50°C ambient. If the temperature rose to 55°C what effect would this have? (Assume that MCCB thermal setting is at maximum)

Solution

At 55°C the ambient compensating factor is 97%, i.e. $160 \times 0.97 = 155A$.

In other words the XS160NJ would act as an MCCB set at 155A, in 55°C.

3

Thermal Magnetic Characteristics and Adjustments

Time, Current & Temperature Curves

XM30PB

Time/current characteristic curves

XM30PB

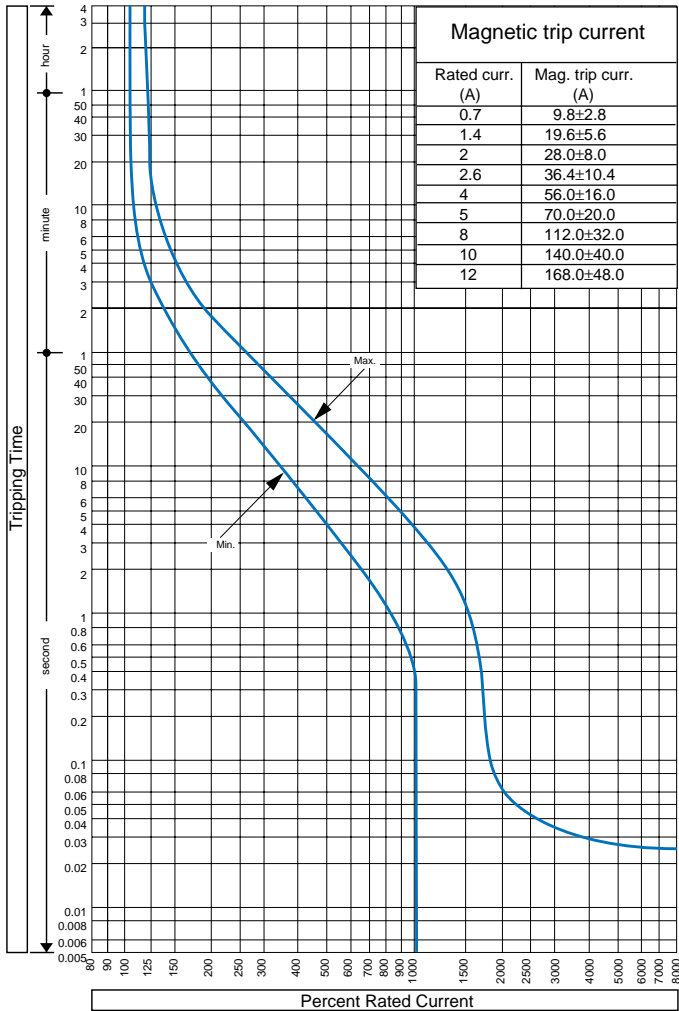

Ambient compensating curves

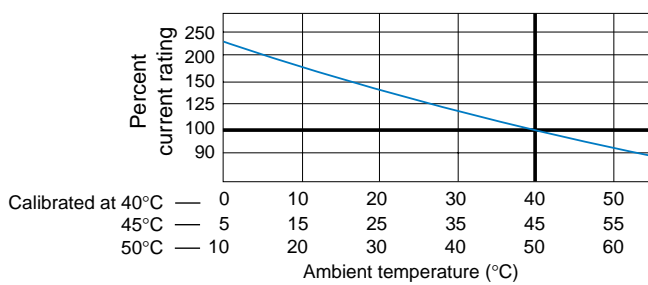

3

Thermal Magnetic Characteristics and Adjustments

Time, Current & Temperature Curves

XS50NB, XE100NS

Time/current characteristic curves

XS50NB

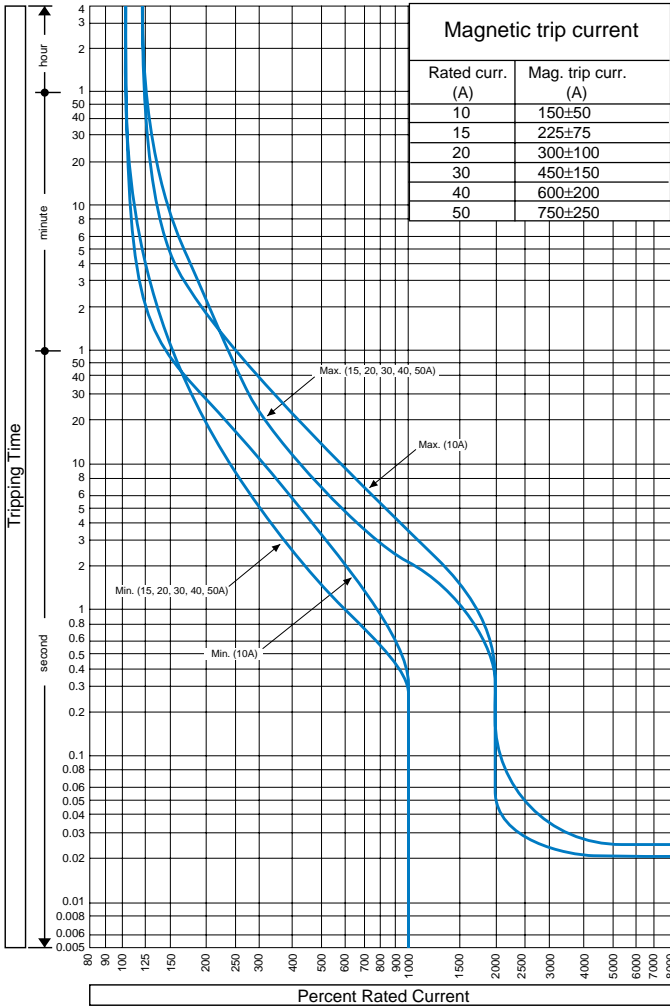

Time/current characteristic curves

XE100NS

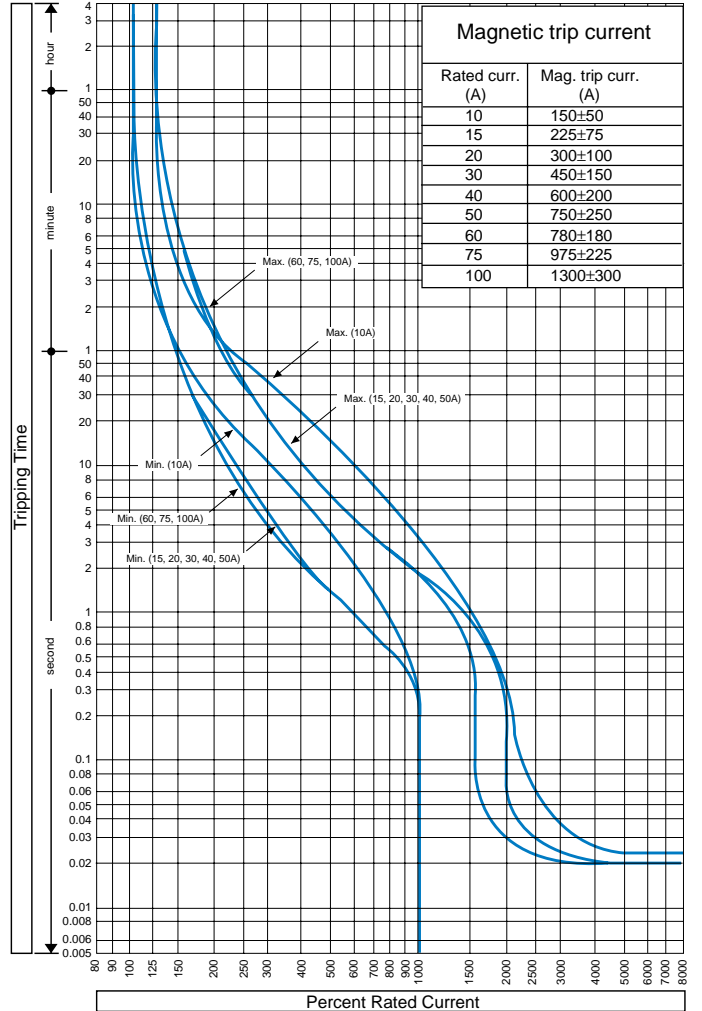

Ambient compensating curves

15-50A

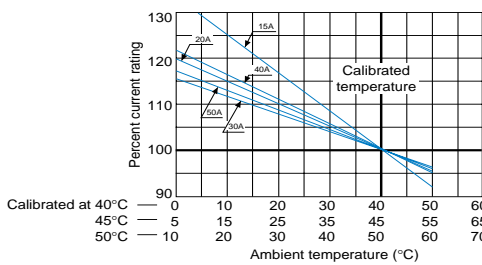

10A

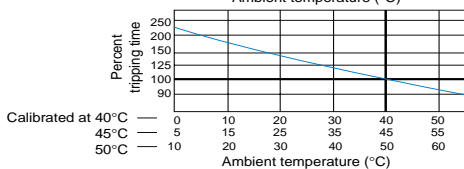

Ambient compensating curves

15-100A

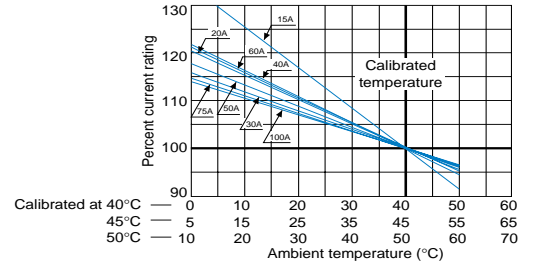

10A

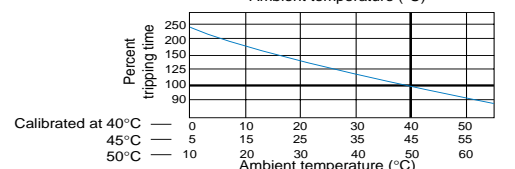

3

Thermal Magnetic Characteristics and Adjustments

Time, Current & Temperature Curves

XS125CS, XS125NS, XS125CJ, XS125NJ, XH125NJ

Time/current characteristic curves

XS125CS, XS125NS

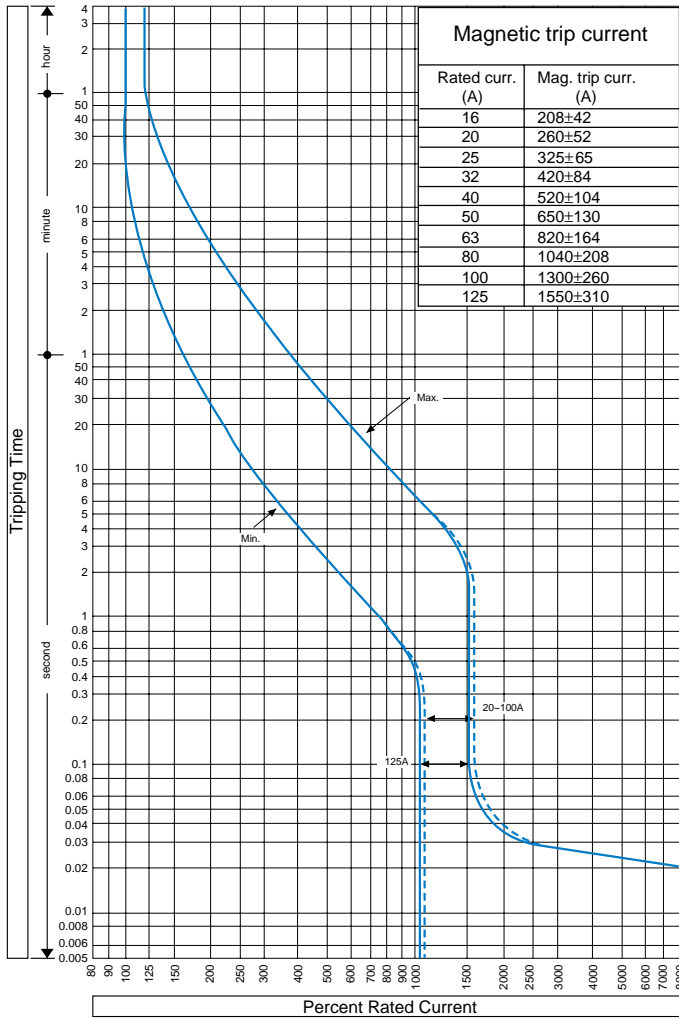

Time/current characteristic curves

XS125CJ, XS125NJ, XH125NJ

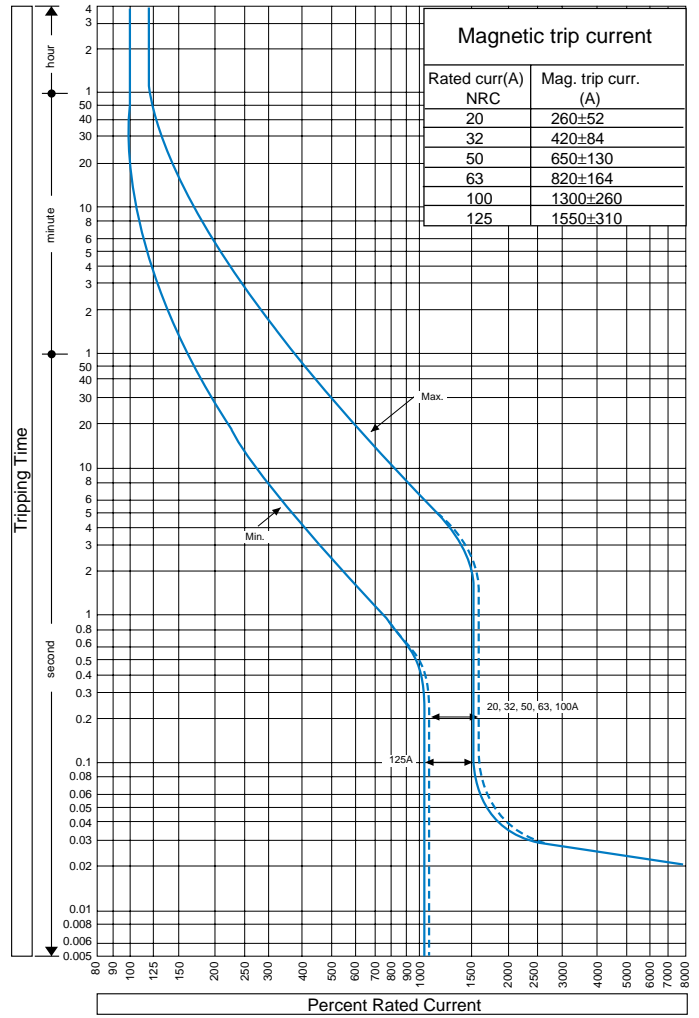

Ambient compensating curves

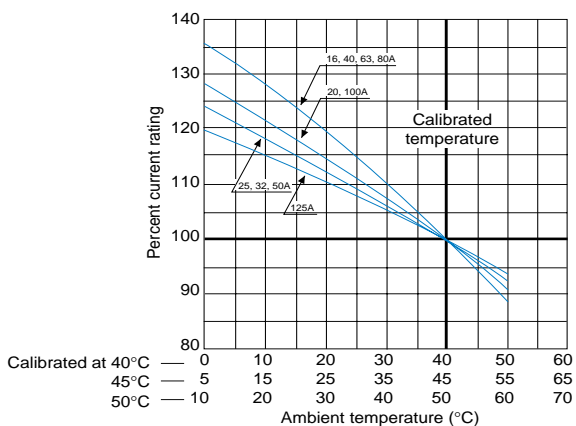

Ambient compensating curves

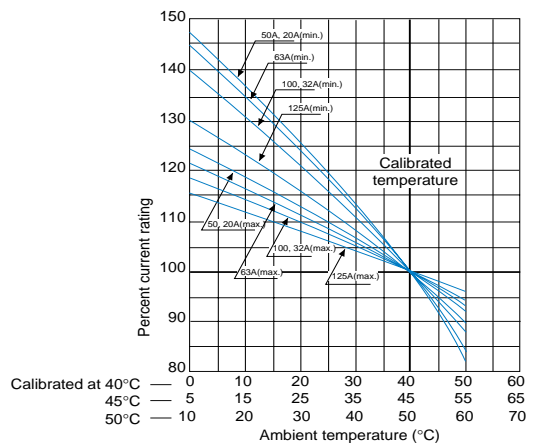

3

Thermal Magnetic Characteristics and Adjustments

Time, Current & Temperature Curves

XE225NS, XS160NJ, XH160NJ, XS250NJ, XS250PJ, XH250NJ

Time/current characteristic curves

XE225NS

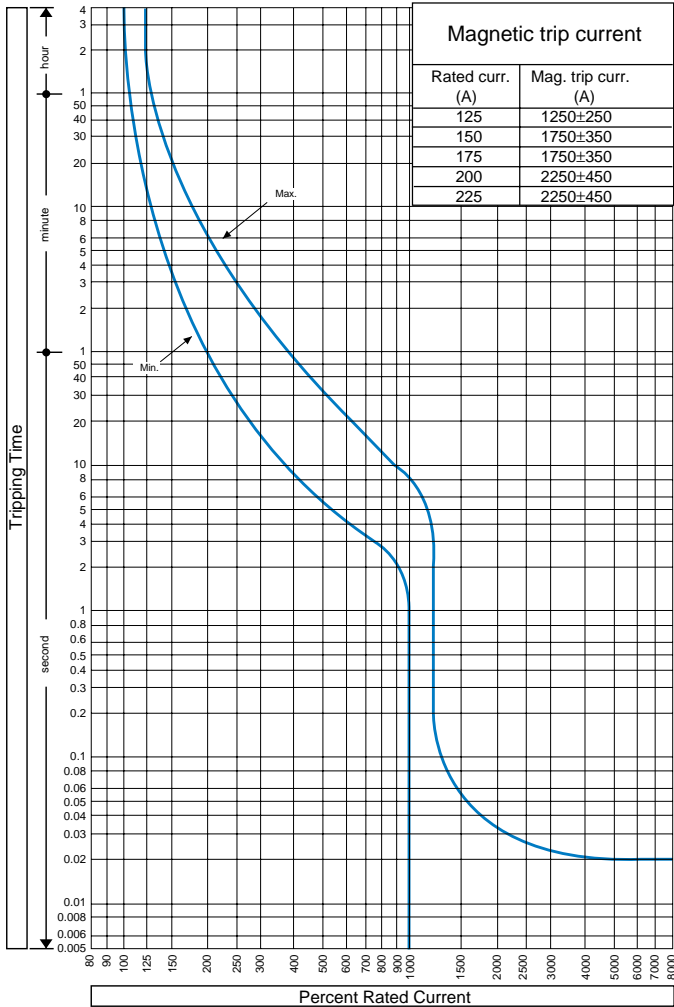

Time/current characteristic curves

XS160NJ, XH160NJ, XS250NJ, XS250PJ, XH250NJ

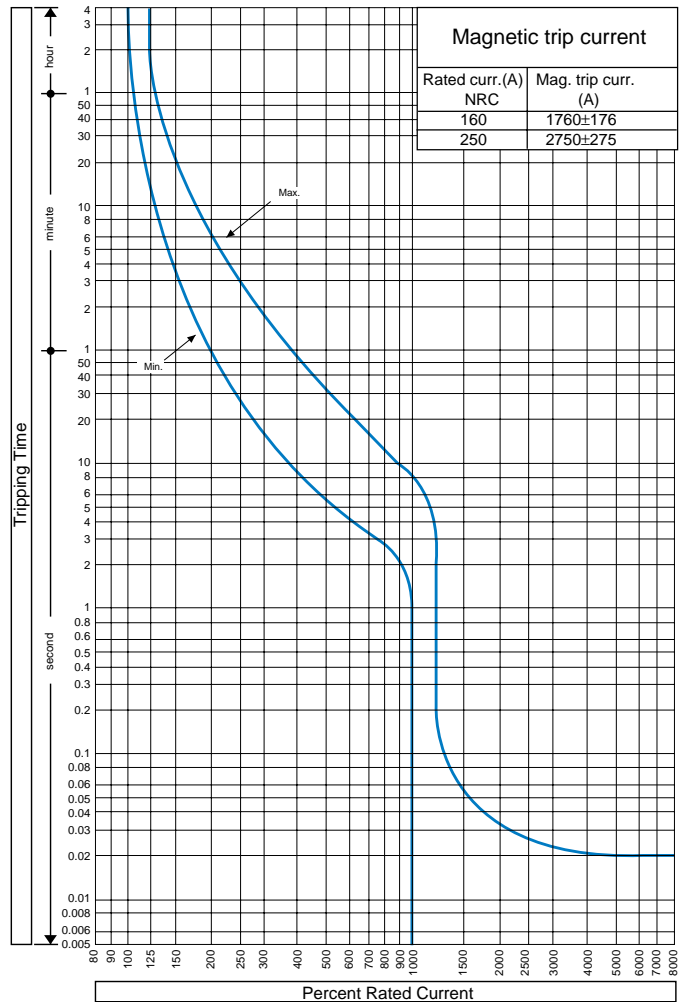

Ambient compensating curves

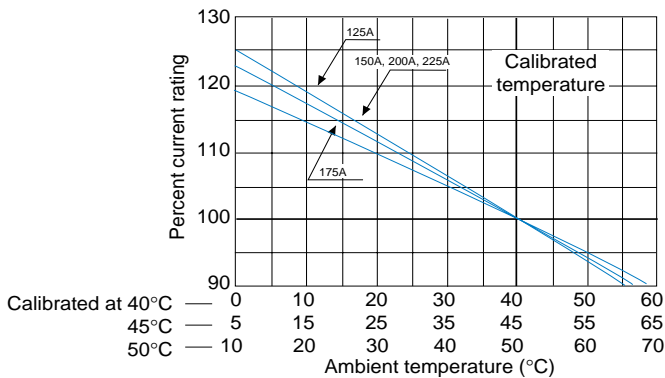

Ambient compensating curves

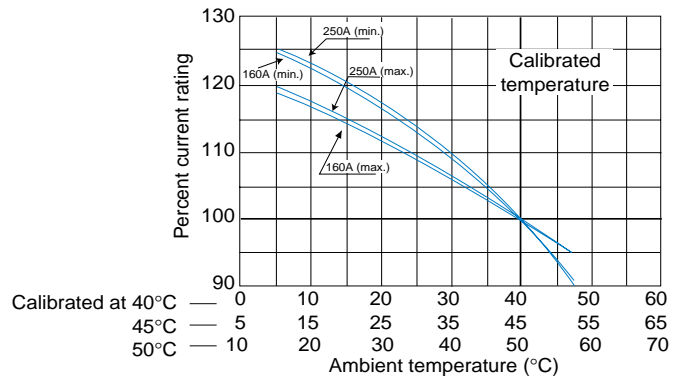

3

Thermal Magnetic Characteristics and Adjustments

Time, Current & Temperature Curves

XE400NS, XS400CJ, XS400NJ

Time/current characteristic curves

XE400NS

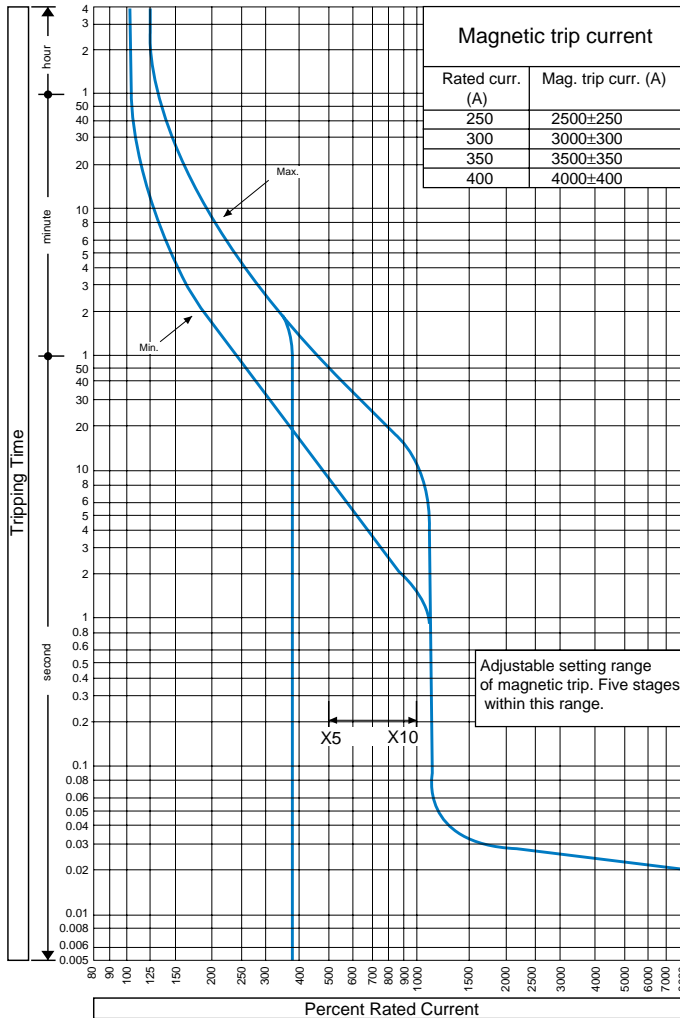

Time/current characteristic curves

XS400CJ, XS400NJ

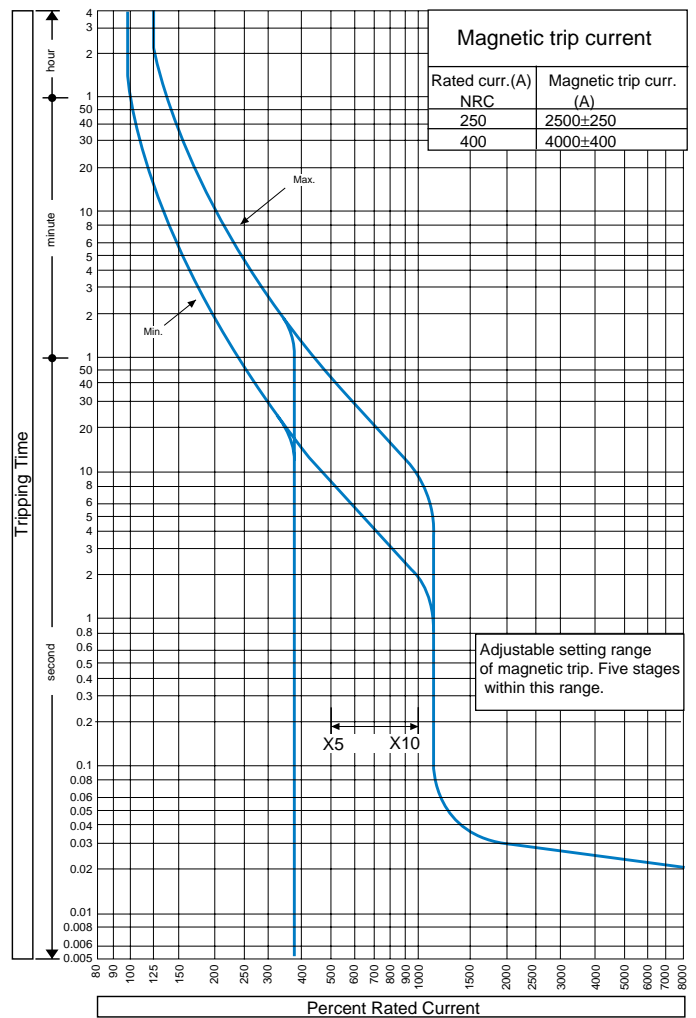

Ambient compensating curves

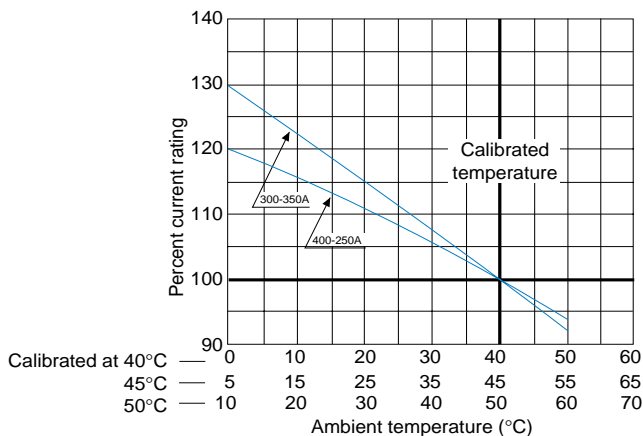

Ambient compensating curves

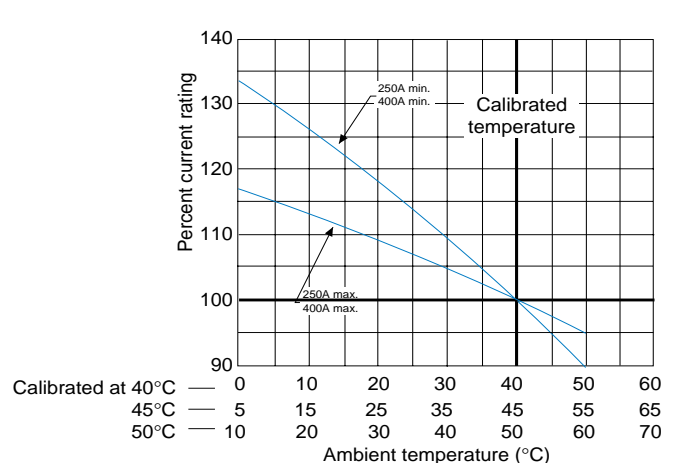

3

Thermal Magnetic Characteristics and Adjustments

Time, Current & Temperature Curves

XE600NS, XS630CJ, XS630NJ

Time/current characteristic curves

XE600NS

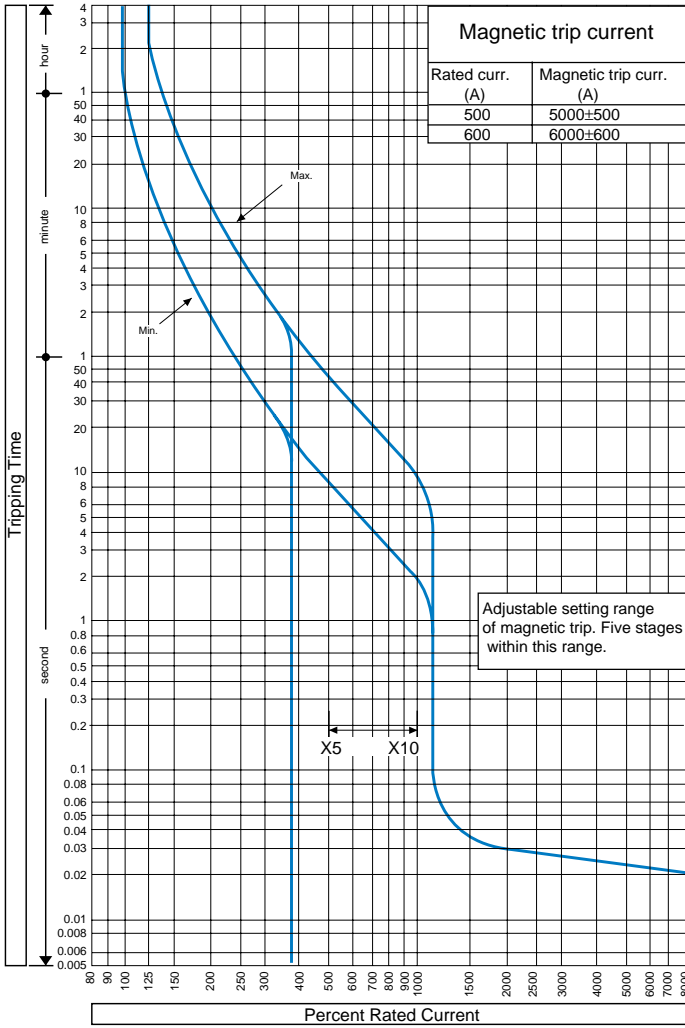

Time/current characteristic curves

XS630CJ, XS630NJ

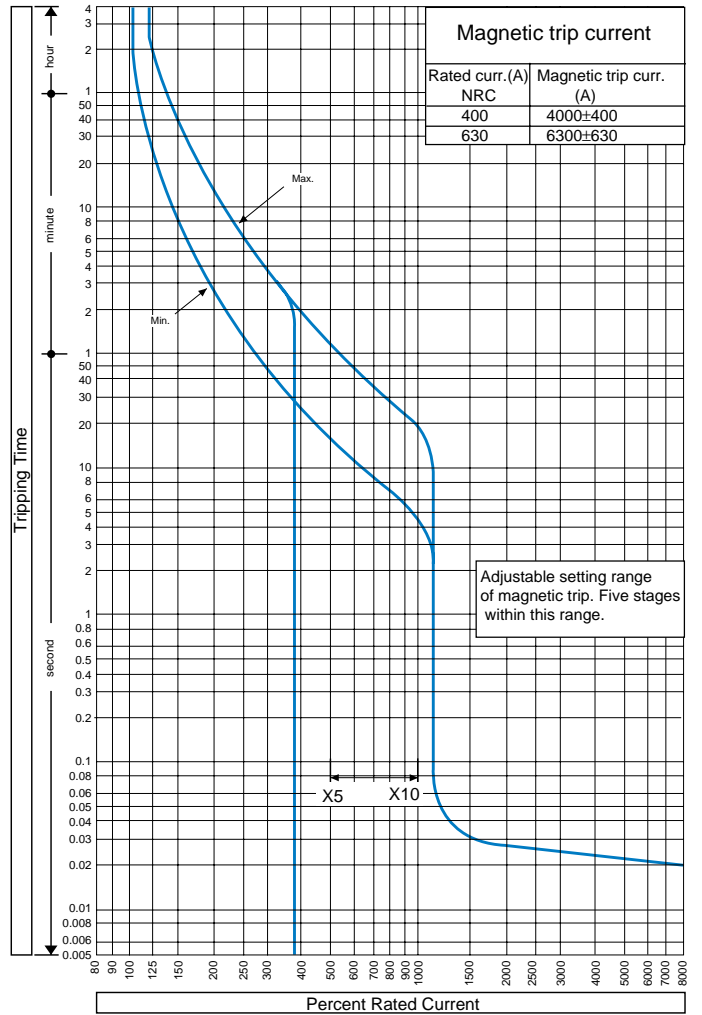

Ambient compensating curves

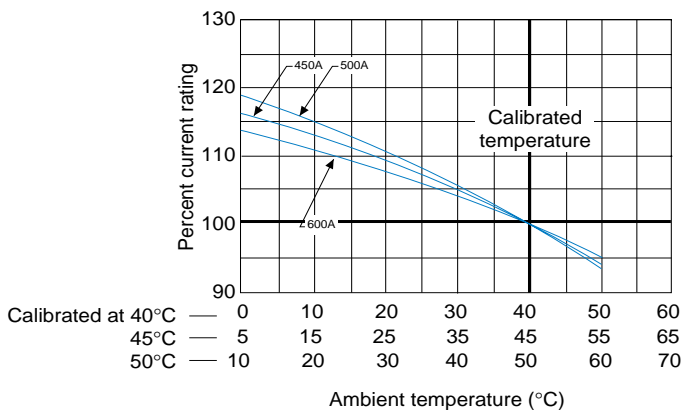

Ambient compensating curves

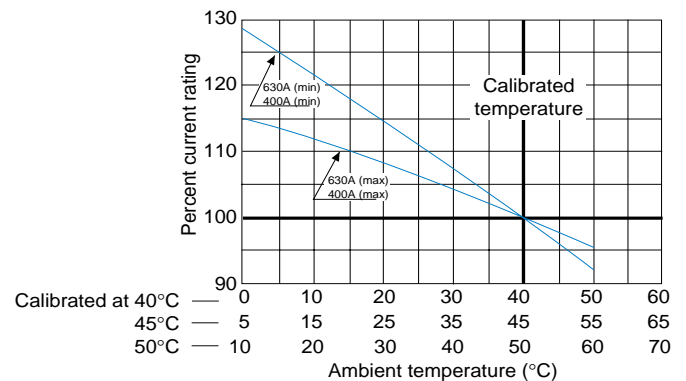

3

Thermal Magnetic Characteristics and Adjustments

Time, Current & Temperature Curves

XS800NJ, XH800PS

Time/current characteristic curves

XS800NJ

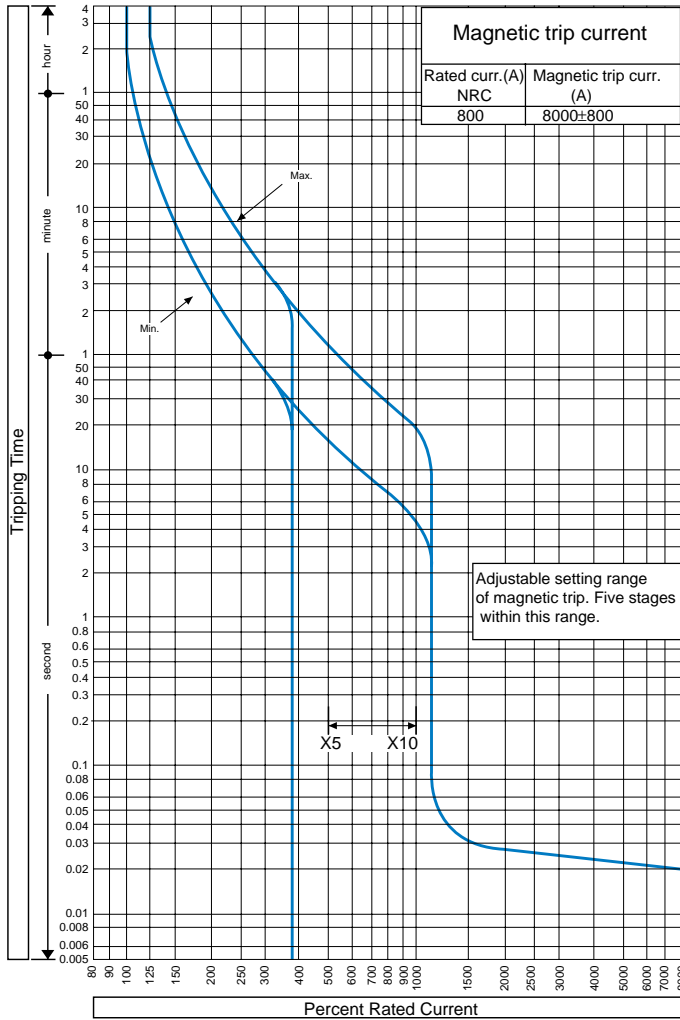

Time/current characteristic curves

XH800PS

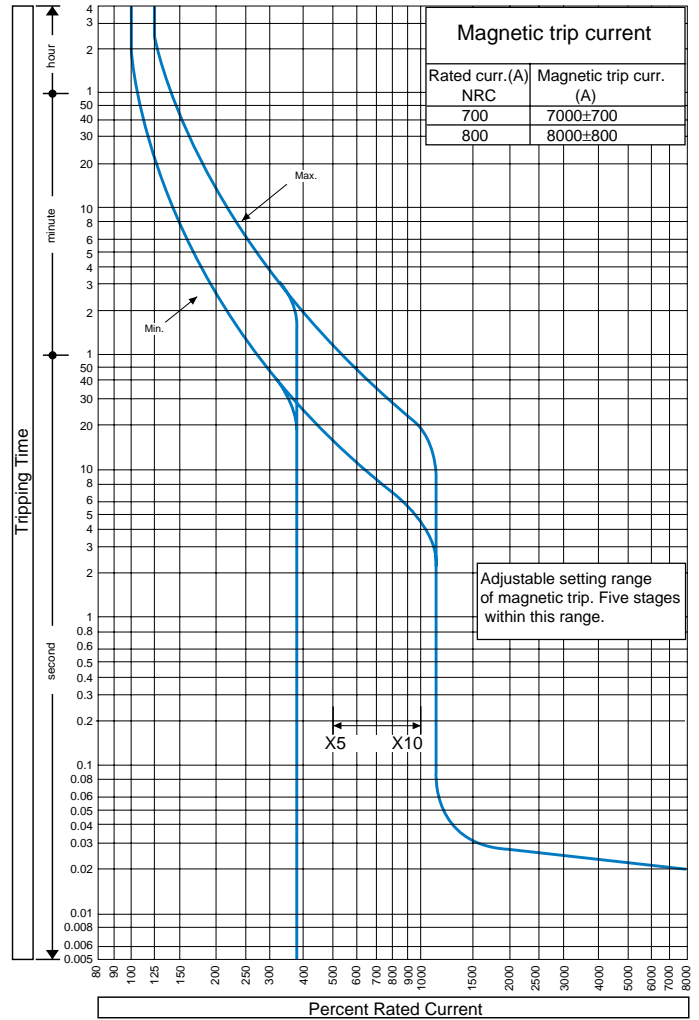

Ambient compensating curves

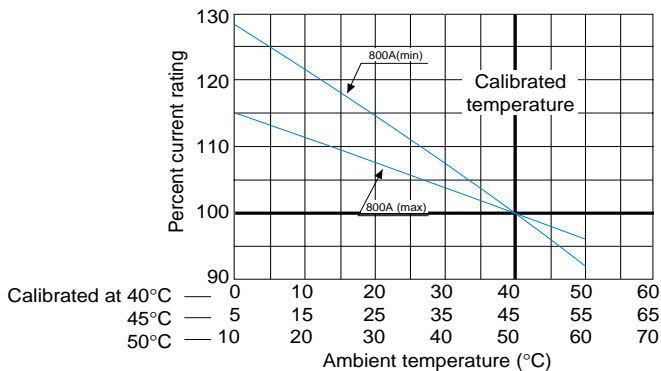

Ambient compensating curves

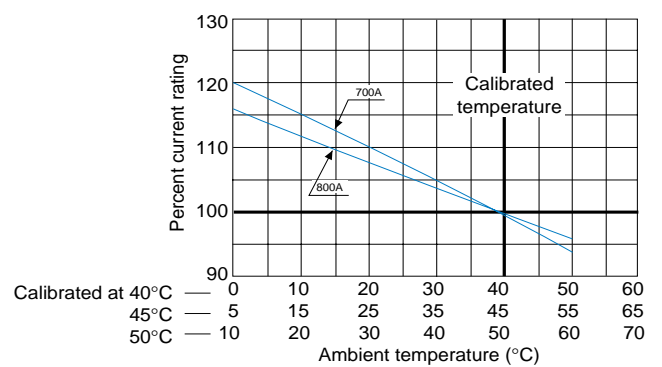

3

Thermal Magnetic Characteristics and Adjustments

Time, Current & Temperature Curves

XS1000ND, XS1250ND, XS1600ND, XS2000ND, XS2500ND

Time/current characteristic curves

XS1000ND

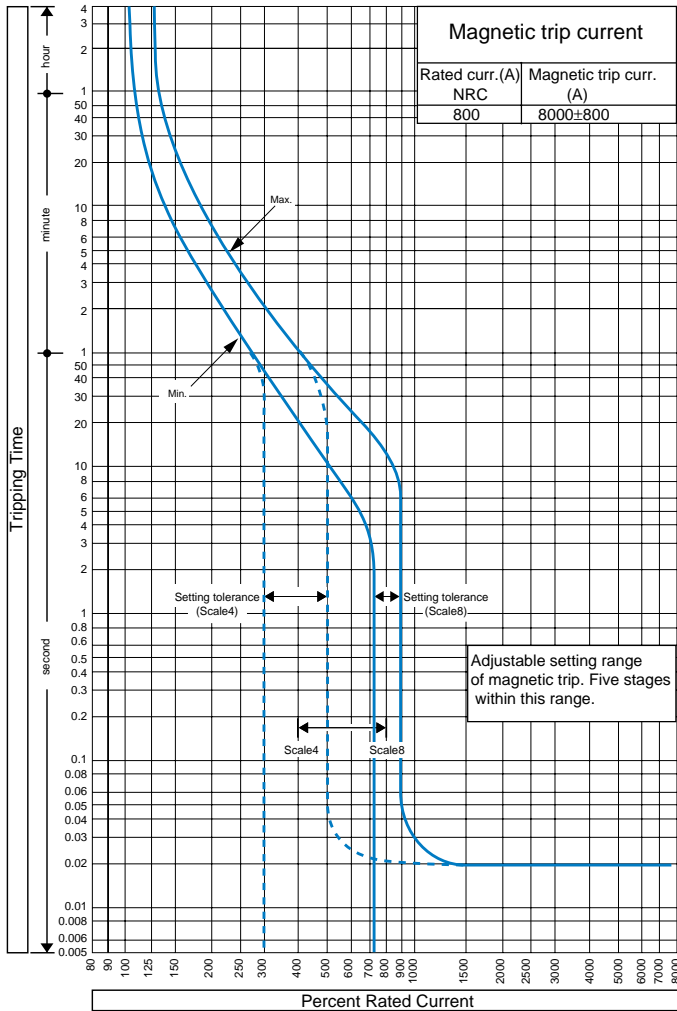

Time/current characteristic curves

XS1250ND, XS1600ND, XS2000ND, XS2500ND

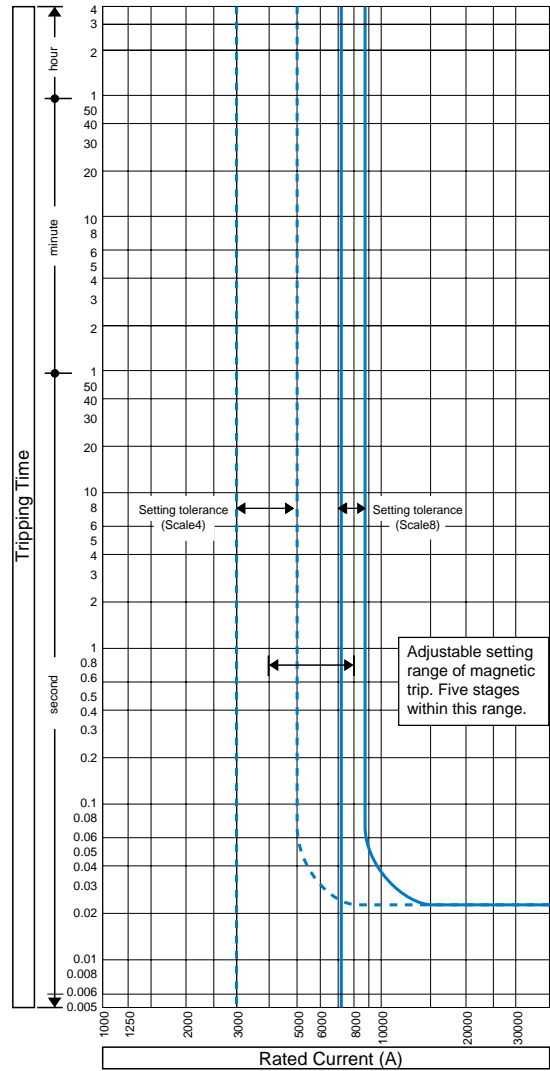

Ambient compensating curves

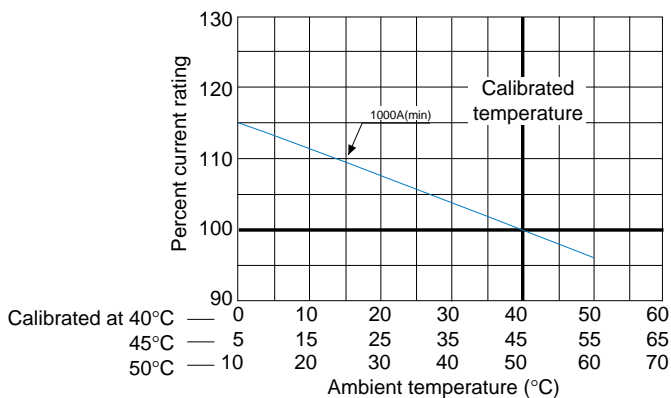

Magnetic trip current (adjustable)

Rated current (A)	Magnetic trip current (A)				
	Scale 8	7.1	6.3	5	4
1000	8000	7100	6300	5000	4000

NOTE: Setting tolerance $\pm 10\%$ at 8000A and $\pm 25\%$ for other settings.

3

Thermal Magnetic Characteristics and Adjustments Special Applications

Generator protection

The steady state current produced by a generator under a fault condition can be as low as 3 to 5 times the rated full load current. In this situation it is advisable to use a 'generator protection' MCCB. This has its magnetic setting calibrated low enough to trip quickly on low generator faults, as shown in the table on the right. The thermal part of the characteristic curve is the same for the corresponding MCCB.



Generator protection INST. settings

Breaker	Rating	Trip current (A)	X In
XS125NJ (SRX5)	20	100	5
	32	160	5
	50	250	5
	63	315	5
	100	500	5
XS125NJ-G	125	625	5
	20	95	4.75
	32	120	3.75
	50	150	3
	63	200	3
XS160NJ-G	100	300	3
	125	375	3
XS250NJ-G	160	400	2.5
XS250NJ-G	250	625	2.5
XS400NJ-G	250	LO=625	2.5
	250	HI=1250	5
	400	LO=1000	2.5
	400	HI=2000	5
XS630NJ-G	400	LO=1000	2.5
	400	HI=2000	5
	630	LO=1600	2.5
	630	HI=3150	5
XS800NJ-G	800	LO=2000	2.5
	800	HI=4000	5

D.C. Application

All standard TemBreak thermal magnetic MCCBs are suitable for DC application up to 250V DC. Refer to Section 2, Ratings and Specifications for details of DC breaking capacity up to 250V.

Above 250V DC, special versions of the standard MCCBs are required, as shown in the table opposite. Refer to the connection diagram below.

Type	breaking capacity (kA) 3 poles in series		
	350V DC	500V DC	600V DC
XS125NJ-D	10	7.5	5
XH125NJ-D	10	7.5	5
XS250NJ-D	10	7.5	5
XH250NJ-D	20	15	10
XS400NJ-D	20	15	15
XS630NJ-D	30	20	30
XS800NJ-D	30	20	20
XS1000ND (2)	30	20	20
XS1250ND (1) (2)	30	20	20
XS1600ND (1) (2)	30	20	20
XS2000ND (1) (2)	30	20	20
XS2500ND (1) (2)	30	20	20

- (1) The breaker is magnetic trip only without overload protection.
(2) UVT can not be fitted.

Note that the DC ratings shown apply when the time constant of the circuit is:

- less than 2.0 ms at approximately rated current (I_n)
- less than 2.5 ms for overloads of between I_n and $2.5I_n$
- less than 7 ms for short circuits of 10 kA or less
- less than 15 ms for short circuits greater than 10 kA

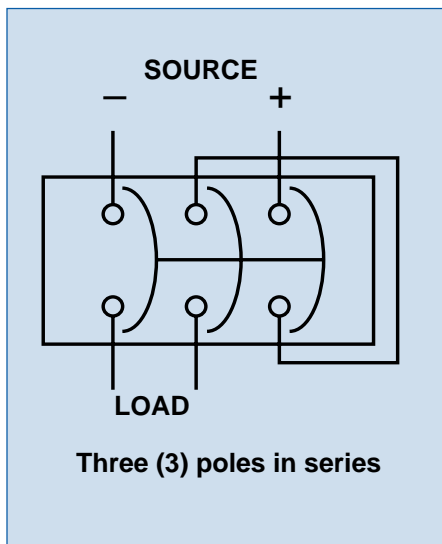

Microprocessor Based Characteristics and adjustments

37-46

- Range 38
- Operation Settings 39
- Operation and Examples 40
- Ground Fault and Pre-Trip Alarm 41
- LED Indication and OCR Controller 42
- Time/Current Curves 43-45
- OCR Checker 46

4

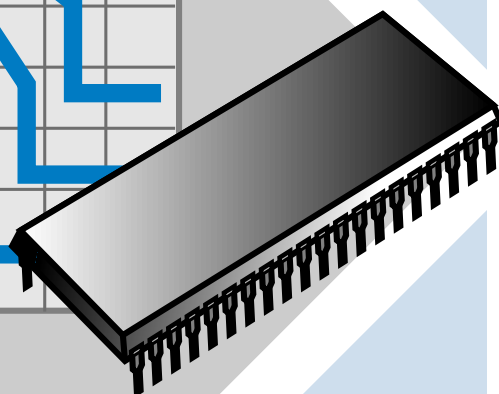
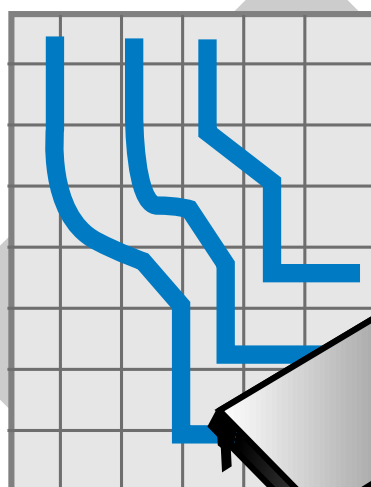

4

Microprocessor Based Characteristics and Adjustments Range

Characteristics

The standard microprocessor based MCCB from Terasaki has the most flexible characteristics on the European market. In addition to the standard overload and short circuit protection, there are a number of options available to meet specific applications.

MCCB Type	LTD	STD	INST	I ² T RAMP	PICK-UP LED	TEST PORT	PTA	GFT	LEDs INTERNAL	LEDs EXTERNAL	SPECIAL HI-INST
XH250PE	⊙	⊙	⊙	⊙	⊙	⊙	○	–	–	○	○
XS400SE-C, XS400SE	⊙	⊙	⊙	⊙	⊙	⊙	○	–	–	○	○
XH400SE	⊙	⊙	⊙	⊙	⊙	⊙	○	–	–	○	○
XS630SE-C, XS630SE	⊙	⊙	⊙	⊙	⊙	⊙	○	○	–	○	○
XH630SE	⊙	⊙	⊙	⊙	⊙	⊙	○	○	–	○	○
XS800SE	⊙	⊙	⊙	⊙	⊙	⊙	○	○	–	○	–
XH800SE	⊙	⊙	⊙	⊙	⊙	⊙	○	○	–	○	–
XS1250SE	⊙	⊙	⊙	⊙	⊙	⊙	○	○	○	–	○
XS1600SE	⊙	⊙	⊙	⊙	⊙	⊙	○	○	○	–	–
XS2000NE	⊙	⊙	⊙	⊙	⊙	⊙	○	○	○	–	○
XS2500NE	⊙	⊙	⊙	⊙	⊙	⊙	○	○	○	–	○

- ⊙ Standard
- Optional
- Not available

Standard for all TemBreak Microprocessor MCCBs

Legend	Application
LTD	Long Time Delay : Overload protection, True R.M.S.
STD	Short Time Delay : Short circuit protection and selectivity
INST	Instantaneous : Short circuit protection, fast acting
I ² t RAMP	: Provides easier grading with downstream fuses
Pick-up LED	: Lights on LTD overload, flashes on PTA pick-up
Test Port	: Facility for TNS-1 OCR checker for calibration checking
PTA	Pre-Trip Alarm : Useful for loadshedding application
GFT	Ground Fault Trip : Protection against ground faults
LEDS	Light Emitting Diodes : Indication of fault for faster diagnosis
HI-INST	High Instantaneous : High inrush applications, increased selectivity

Standard for all TemBreak Microprocessor MCCBs

Access to Setting Dials

To adjust the settings on the microprocessor TemBreak, the sealed label must be broken and the covering fixing screws removed. To adjust the individual trip settings, turn the setting dial with a flat bladed screw driver. Align the setting required between the black dots marked on the dial.



XS400SE

Sealed label
Spare sealing labels



XS400SE (cover removed)

Setting Dials

4

Microprocessor Based Characteristics and Adjustments Operation Settings

Standard Time Current Curves

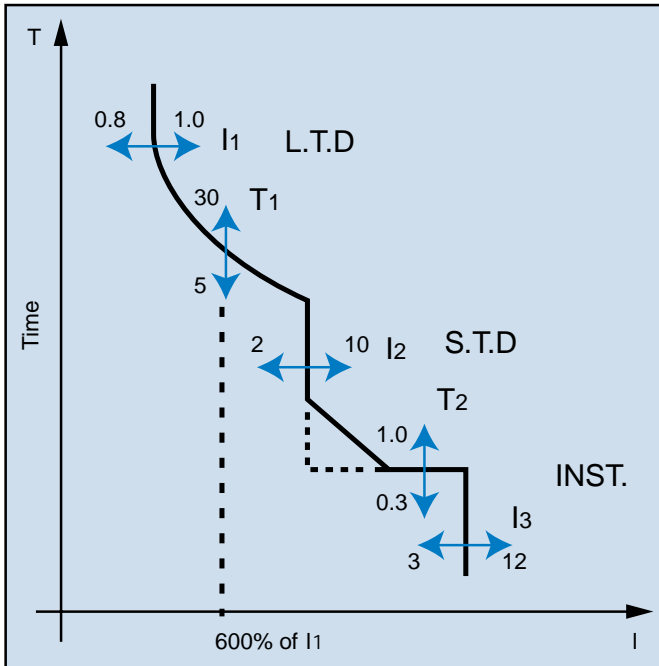

Each part of the characteristic curve can be independently adjusted. This unique adjustability of LTD, STD and INST enables the standard microprocessor MCCB to achieve more than 200,000 permutations of its time/current characteristic. This makes the TemBreak microprocessor range one of the most flexible on the market. To complement this range, Terasaki have developed TemCurve, selectivity analysis software which contains the full range of TemBreak MCCBs on database. This software package highlights the full benefit of having highly adjustable microprocessor MCCBs when involved with difficult selectivity problems. Please refer to page 10 for more information.

Standard Microprocessor Adjustments

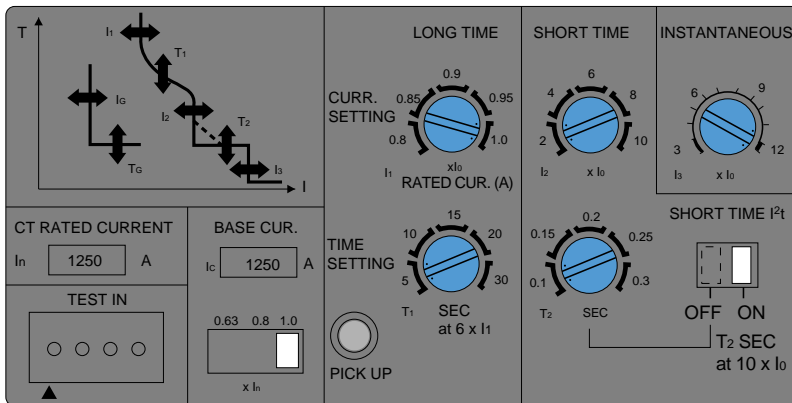

The I^2t ramp switch, which is provided as standard, assists in discrimination with downstream fuses. With the switch off, the STD operates with a definite time characteristic: with the switch on, the characteristic alters to a ramp: , cutting off the corner which poses a potential selectivity problem.

Setting Dial

Available Adjustments

Setting Dial	Available Adjustments	Units
Base Current Setting	I_0 0.63 - 0.8 - 1.0 x I_n	Amps
LTD Pick up	I_1 0.8 - 0.85 - 0.9 - 0.95 - 1.0 x I_0	Amps
LTD Setting	T_1 5 - 10 - 15 - 20 - 25 - 30 (at I_1 x 600%)	Secs
STD Pick up	I_2 2 - 4 - 6 - 8 - 10 x I_0	Amps
STD Setting	T_2 0.1 - 0.15 - 0.2 - 0.25 - 0.3	Secs
INST Pick up	I_3 3 - 12 x I_0 (continuously adjustable)	Amps

Note: A special generator T_1 setting adjustment of 1-5 sec (at I_1 x 600%), and fixed high instantaneous (I_3) setting for high inrush/high selectivity are also available. Please contact Terasaki for details.

4

Microprocessor Based Characteristics and Adjustments Operation & Examples

Overload Adjustment

The rated current of the microprocessor based TemBreak is adjusted using two current multipliers. This process achieves high accuracy adjustment from 50% to 100%. These are the LTD pickup dial I_1 and the Base Current I_0 selector switch.

The rated current (LTD pickup) is achieved as follows:

$$I_{RATED} = I_n \times I_0 \times I_1$$

In the example shown on the right the rating would be:

$$I_{RATED} = 1250 \times 1.0 \times 1.0 = 1250A$$

In total there are 15 possible increments of adjustment between 50 and 100% as shown below.

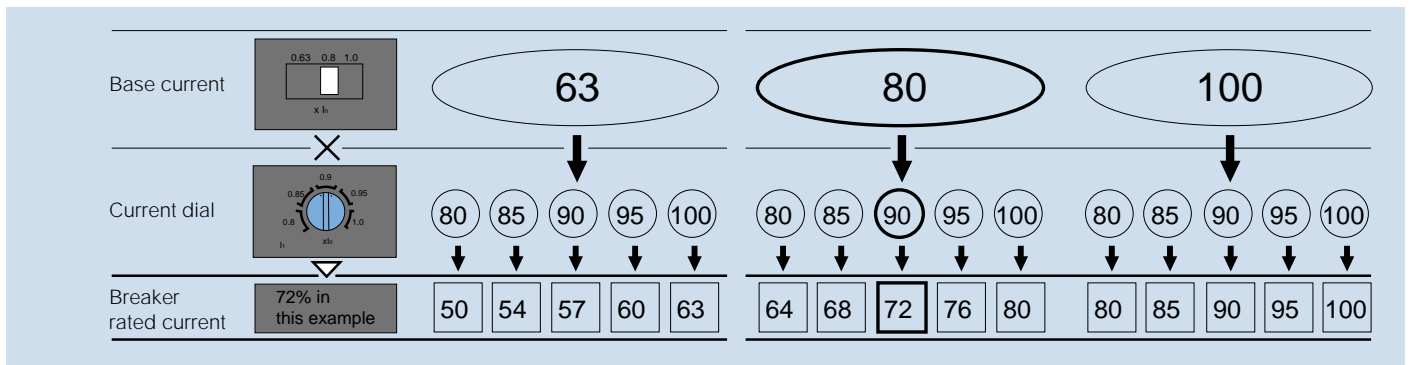
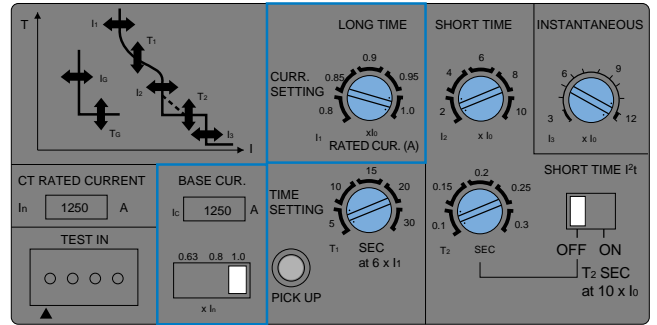

Example - Settings

In the example shown on the right what are all the settings in Amps?

- Solution**
- IRATING LTD pickup = $I_n \times I_0 \times I_1$
 $1250 \times 0.8 \times 0.9 = 900A$
 - STD pickup = $I_n \times I_0 \times I_2$
 $1250 \times 0.8 \times 4 = 4000A$
 - INST pickup = $I_n \times I_0 \times I_3$
 $1250 \times 0.8 \times 12 = 12,000A$
 - GFT pickup = $I_n \times I_G$
 $1250 \times 0.1 = 125A$
(Note that GFT is a function of I_n and not I_0)

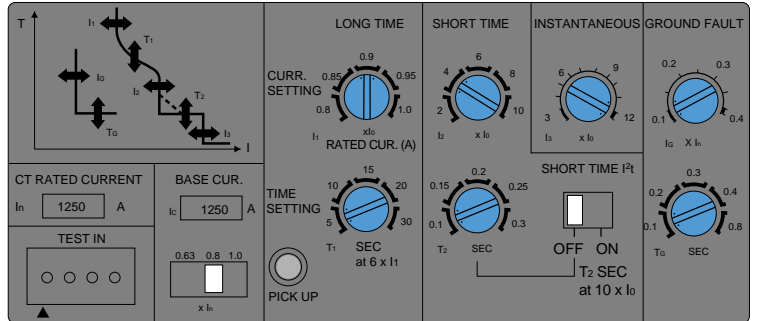

Example - Time/Current Curves

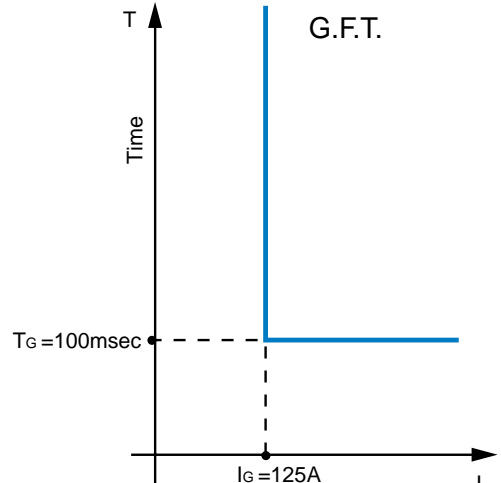
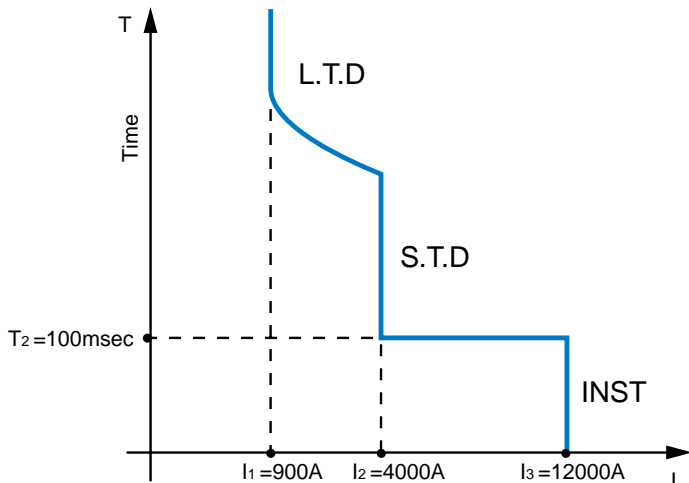

4

Microprocessor Based Characteristics and Adjustments

Ground Fault & Pre Trip Alarm

Ground Fault Adjustments

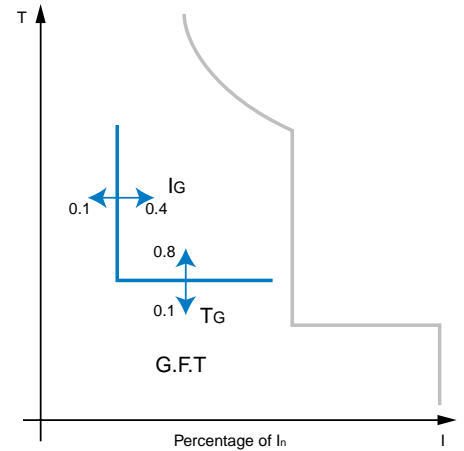
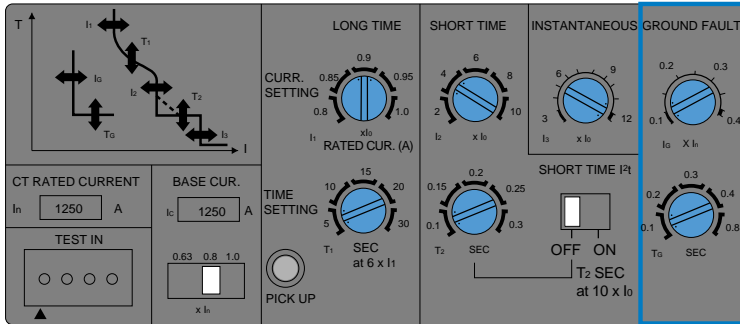

Setting Dial Available Adjustments

GFT Pickup	I_g	0.1 to 0.4 continuously adjustable $\times I_n$	Amps
GFT Setting	T_g	0.1 - 0.2 - 0.3 - 0.4 - 0.8	seconds

When a 3 pole MCCB is used on a 3 phase 4 wire system a separate CT is required for the neutral line. No control power is required for this option.

MCCB Frame Size	A	B	C	$\varnothing D$	E	F	H	CM	M	N	W(kg)
630A, 800A	105	100	40	8	50	75	110	57	50	20	1.2
1250A, 1600A, 2000A, 2500A	140	110	50	10	80	85	145	75	85	35	2.2

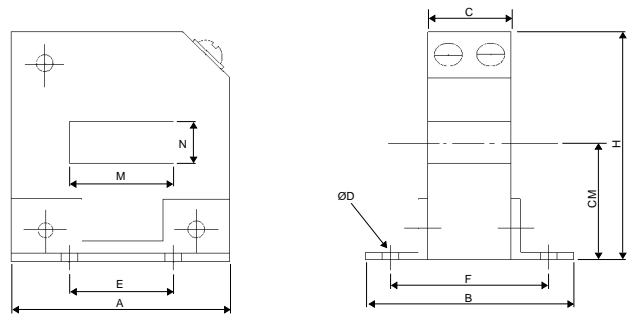

Note: CT mounting base can be rotated by 90°

Pre Trip Alarm Adjustments

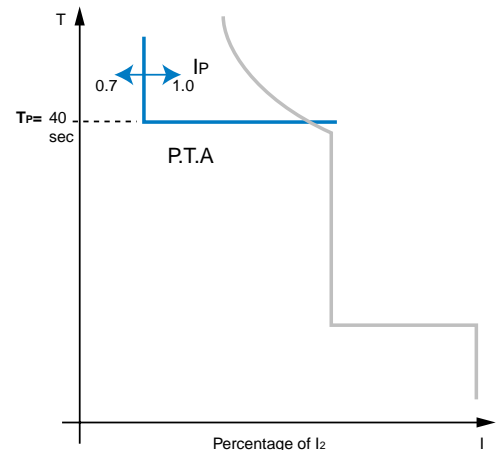
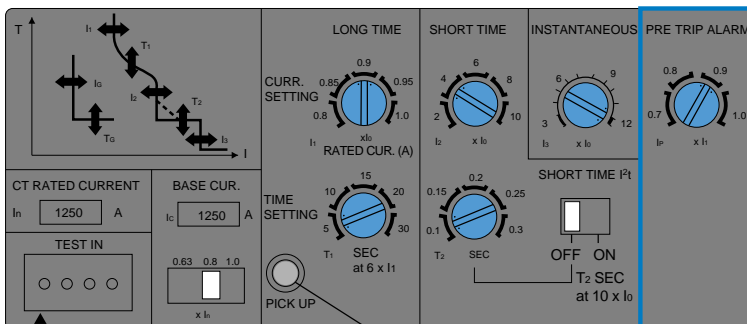

Setting Dial Available Adjustments

PTA Pickup	I_p	0.7 - 0.8 - 0.9 - 1.0 $\times I_1$	Amps
PTA Setting	T_p	Fixed at 40 secs	-

The PTA (Pre-Trip Alarm) option continuously monitors the true r.m.s value of the load current. When the load current exceeds the preset current value I_p the pick-up led 'flashes' to provide a local alarm. If the current continues to exceed the I_p setting for 40 secs or more a volt free contact will close to provide a remote alarm. This volt free contact could also be used to trip non-essential load or start additional generator capacity.

The volt free contact will only reset if the load current decreases to a value below I_p or the control voltage is interrupted. To operate the PTA function an OCR controller is required, this is supplied as standard with the option.

Output Contact

Normally open contact, (1a) Integral lead is standard length (450mm)

	Resistive load		Inductive load
Rating of contact	250V AC	125V A (2A max)	20V A (2A max)
Tripped indication	220V AC	60W (2A max)	10W (2A max)

4

Microprocessor Based Characteristics and Adjustments

LED indication & OCR Controller

LED Indication

Faster Fault Diagnostics can be achieved through indication of fault type. On occurrence of a fault the relevant LED will light for that particular fault conditions.

LED	Fault Type
LTD	Overload
STD/INST	Short Circuit
GFT	Earth Fault
Pick-up	This flashes for PTA pick-up and lights for LTD pick-up

On 1250AF and above the LED's are integral to the OCR. On breakers of below 1250AF, LED's are mounted on a block on the right hand side of the breaker. Please contact Terasaki for details.

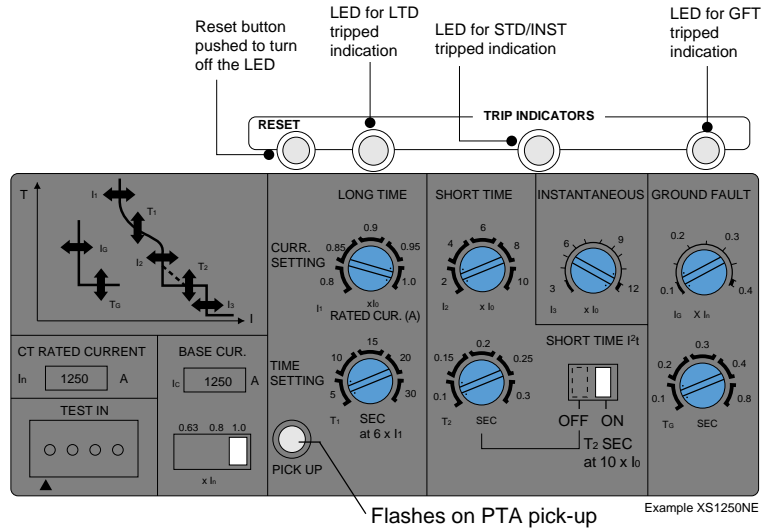

OCR controller (PTA and trip indication)

The OCR controller is installed in the left hand side of the breaker (standard). This can also be installed externally to the breaker (please specify when ordering).

Note: Installation position and accessory lead terminal block arrangements, refer to pages 78-79.

OCR controller specifications

Control power source 100-120 VAC or 200-240 VAC
Terminals OP₁ and OP₂

Consumption 2VA

Note: The permissible range of control power is 85-110% of the rated voltage.

OCR Controller connection diagram

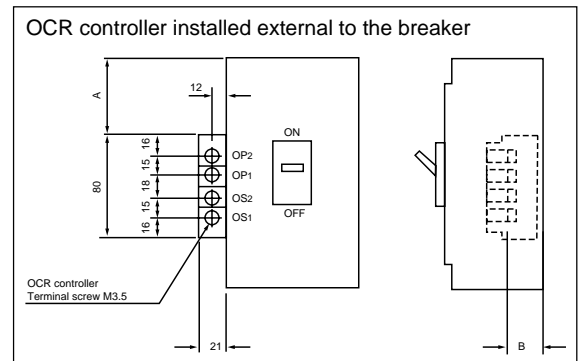
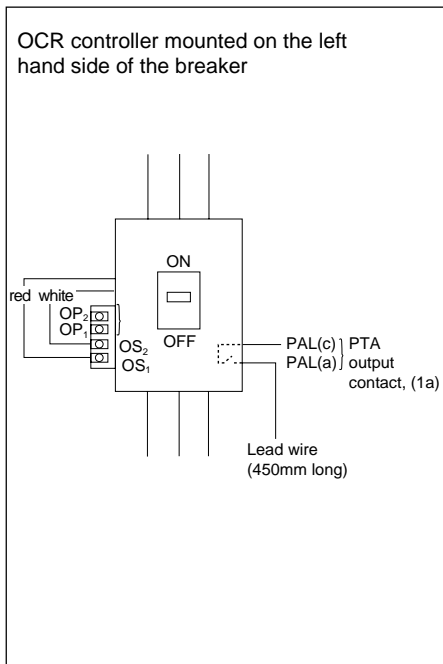

Dimensions table (mm)

Frame (A)	Type of MCCB	A		B
		With UVT controller	Without UVT controller	
250	XH250PE	34	97	48
	XS400SE-C XS400SE XH400SE	34	97	
630	XS630SE-C XS630SE XH630SE	64	151	60
	XS800SE XH800SE	64	151	
1250	XS1250SE	51	114	72
1600	XS1600SE	51	114	92
2000	XS2000NE	54	180	115
2500	XS2500NE	54	180	115

4

Microprocessor Based Characteristics and Adjustments

Time/Current Curves

Time/current characteristic curves

XH250PE, XS400SE-C, XS400SE, XH400SE

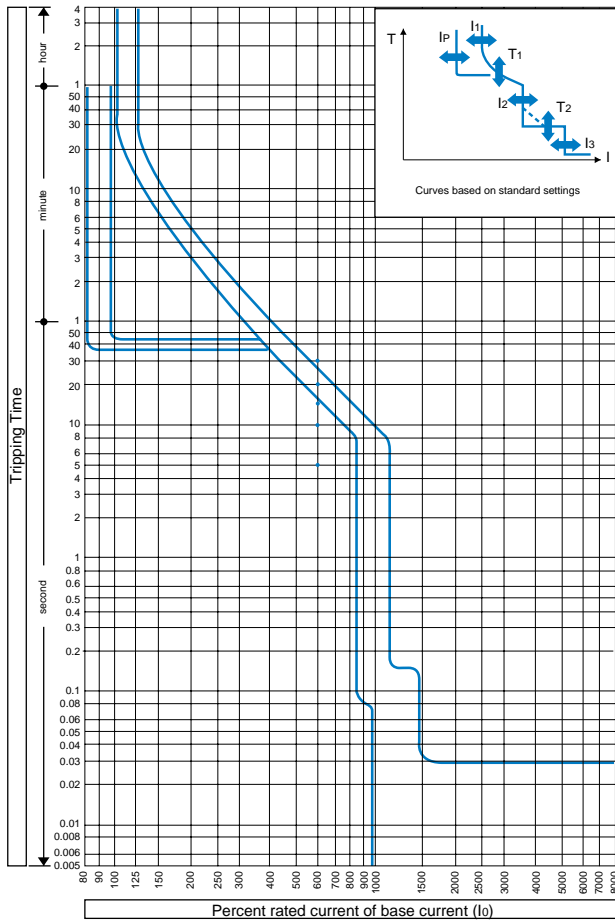

Time/current characteristic curves

XS630SE-C, XS630SE, XH630SE, XS800SE, XH800SE

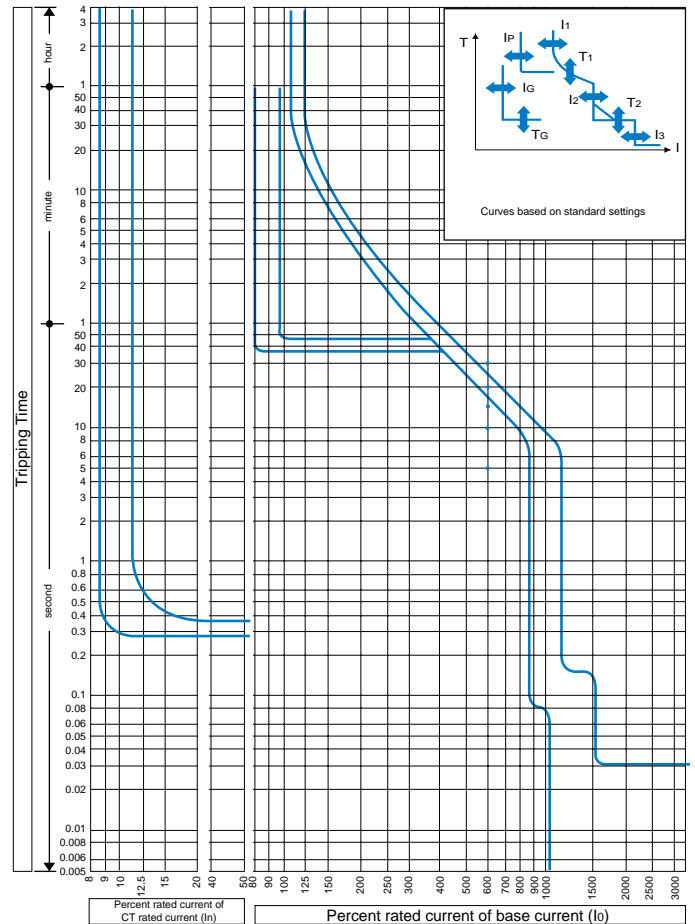

Overcurrent tripping characteristics

CT rated current (A) (In)	250,400
Base current setting (A): (I0)	(In) x (0.63-0.8-1.0)
Long time-delay pick-up current (A): (I1)	(I0) x (0.8-0.85-0.9-0.95-1.0) Non-tripping at (I1) setting x 105% and below. Tripping at 125% and above.
Long time-delay time settings (S) (T1)	(5-10-15-20-30) at (I1) x 600% current. Setting tolerance ± 20%
Short time-delay pick-up current (A): (I2)	(I0) x (2-4-6-8-10) Setting tolerance ± 15%
Short time-delay time settings (S) (T2)	Opening time (0.1, 0.15, 0.2, 0.25, 0.3) in the definite time-delay. Total clearing time is + 50 mS and resettable time -20mS for the time-delay setting
Instantaneous trip pick-up current (A) (I3)	Continuously adjustable from (I0) x (3 to 12) Setting tolerance ± 20%
* Pre-trip alarm pick-up current (A) (IP)	(I1) x (0.7, 0.8, 0.9, 1.0) Setting tolerance ± 10%
* Pre-trip alarm time setting (S) (TP)	40 fixed definite time-delay. Setting tolerance ± 10%

Note: * Optional

Note: The underlined values will be applied as standard ratings unless otherwise specified when ordering.

Overcurrent tripping characteristics

CT rated current (A) (In)	630,800
Base current setting (A): (I0)	(In) x (0.63-0.8-1.0)
Long time-delay pick-up current (A): (I1)	(I0) x (0.8-0.85-0.9-0.95-1.0) Non-tripping at (I1) setting x 105% and below. Tripping at 125% & above.
Long time-delay time settings (S) (T1)	(5-10-15-20-30) at (I1) x 600% current. Setting tolerance ± 20%
Short time-delay pick-up current (A): (I2)	(I0) x (2-4-6-8-10) Setting tolerance ± 15%
Short time-delay time settings (S) (T2)	Opening time (0.1, 0.15, 0.2, 0.25, 0.3) in the definite time-delay. Total clearing time is + 50 mS and resettable time -20mS for the time-delay setting.
Instantaneous trip pick-up current (A) (I3)	Continuously adjustable from (I0) x (3 to 12) Setting tolerance ± 20%
* Pre-trip alarm pick-up current (A) (IP)	(I1) x (0.7, 0.8, 0.9, 1.0) Setting tolerance ± 10%
* Pre-trip alarm time setting (S) (TP)	40 fixed definite time-delay. Setting tolerance ± 10%
* Ground fault trip pick-up current (A): (IG)	Continuously adjustable from (In) x (0.1 to 0.4) Setting tolerance ± 15%
* Ground fault trip time setting (S): (TG)	Opening time (0.1-0.2-0.3-0.4-0.8) in the definite time-delay. Total clearing time is + 50mS and resettable time is - 20mS for the time-delay settings

Note: * Optional

Note: The underlined values will be applied as standard ratings unless otherwise specified when ordering.

Time/current characteristic curves

XS1250SE, XS1600SE, XS2000NE, XS2500NE

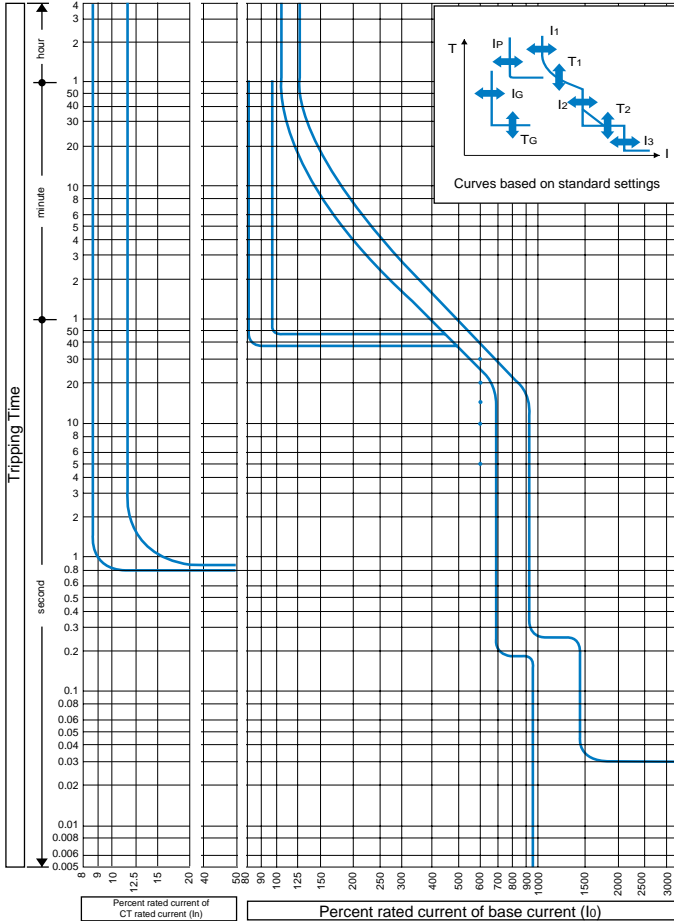

Overcurrent tripping characteristics

CT rated current (A) (I_n)	1000, 1250, 1600, 2000, 2500
Base current setting (A): (I_o)	$(I_n) \times (0.63-0.8-1.0)$
Long time-delay pick-up current (A): (I_1)	$(I_o) \times (0.8-0.85-0.9-0.95-1.0)$ Non-tripping at (I_1) setting $\times 105\%$ and below. Tripping at 125% & above.
Long time-delay time settings (S) (T_1)	(5-10-15-20-30) at (I_1) $\times 600\%$ current. Setting tolerance $\pm 20\%$
Short time-delay pick-up current (A): (I_2)	$(I_o) \times (2-4-6-8-10)$ Setting tolerance $\pm 15\%$
Short time-delay time settings (S) (T_2)	Opening time (0.1, 0.15, <u>0.2</u> , 0.25, 0.3) in the definite time-delay. Total clearing time is + 50 mS and resettable time -20mS for the time-delay setting.
Instantaneous trip pick-up current (A) (I_3)	Continuously adjustable from $(I_o) \times (3$ to $12)$ Setting tolerance $\pm 20\%$
* Pre-trip alarm pick-up current (A) (I_p)	$(I_1) \times (0.7, 0.8, 0.9, 1.0)$ Setting tolerance $\pm 10\%$
* Pre-trip alarm time setting (S) (T_p)	40 fixed definite time-delay. Setting tolerance $\pm 10\%$
* Ground fault trip pick-up current (A): (I_g)	Continuously adjustable from $(I_n) \times (0.1$ to $0.4)$ Setting tolerance $\pm 15\%$
* Ground fault trip time setting (S): (T_g)	Opening time (0.1-0.2-0.3-0.4- <u>0.8</u>) in the definite time-delay. Total clearing time is + 50mS and resettable time is - 20mS for the time-delay settings

Note: * Optional

Note: The underlined values will be applied as standard ratings unless otherwise specified when ordering.

4

Microprocessor Based Characteristics and Adjustments

Time/Current Curves

Mathematical Analysis

MCCB Curves

A microprocessor MCCB has three main regions on its overcurrent tripping characteristic, namely Long Time Delay (LTD) for overload protection, Short Time Delay (STD) and Instantaneous (INST), both for short-circuit protection.

The following is an insight into how these curves interact and could act as a guide for hand-drawing the curves. TemCurve Selectivity Analysis Software is available for computerised generation of curves (refer to page 10).

Firstly consider the following basic characteristic curve shown in figure 1.

The LTD takes the form of a curve and has the following characteristic equation:

$$(I^2 - 1) \cdot t = k$$

where 'k' is a constant. To determine k, the calibration point of the LTD should be used, i.e. $t = T_1$ at $I_1 = 6$ (600%).

IEC-947-2 states that a breaker must not trip below 105% of its rated current, and always trip at 130% of its rated current. Terasaki microprocessor MCCBs however are calibrated to trip between 105% and 125%, giving them a higher degree of accuracy. If the middle point is taken then the pick-up of the MCCB is 115% of its rated current.

The STD and INST parts of the curve can be drawn more easily as they are simply a series of horizontal and vertical lines determined by the I_2 and T_2 settings for the STD, and I_3 setting for the INST.

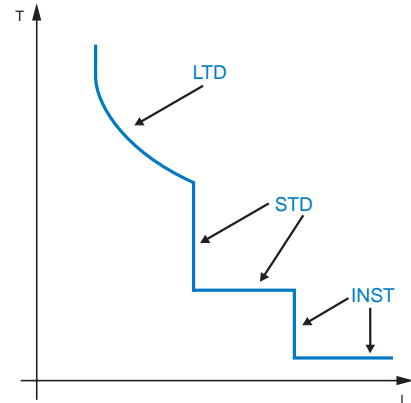

Example

If we assume that we have:

XS1250SE with 1250A CT's and
 $I_0 = 1, I_1 = 0.8, T_1 = 30\text{secs}$,
 $I_2 = 8, T_2 = 0.2\text{secs}$ and
 $I_3 = 12$

then the characteristic curve can be constructed as follows.

To draw the LTD we firstly need to determine the constant **k**, as follows:

$$k = (I^2 - 1) \cdot t = (6^2 - 1) \cdot 30 = 1050$$

giving the characteristic equation:

$$(I^2 - 1) \cdot t = 1050$$

By simple arithmetic the tripping times for each level of overload can now be determined.

$$\text{For } 400\% \text{ overload (for the example this is equivalent to } 1250 \times 1.0 \times 0.8 \times 4 = 4000\text{A)}. \quad t = \frac{1050}{(I^2 - 1)} = \frac{1050}{(4^2 - 1)} = 70 \text{ secs}$$

The STD and INST can be constructed as follows with

$$I_2 = I_n \times I_0 \times I_2$$

$$I_3 = I_n \times I_0 \times I_3$$

*Please note that 20ms is taken as an average time for the INST trip of the MCCB as it is the maximum time it will take the MCCB to trip. In practice the breaker will open much faster, particularly at high faults where the current limiting qualities of the MCCB become more effective.

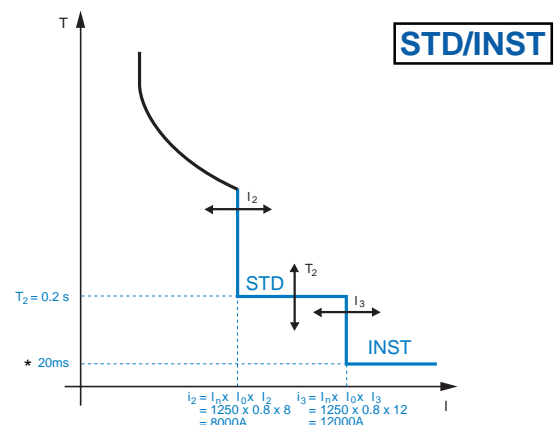
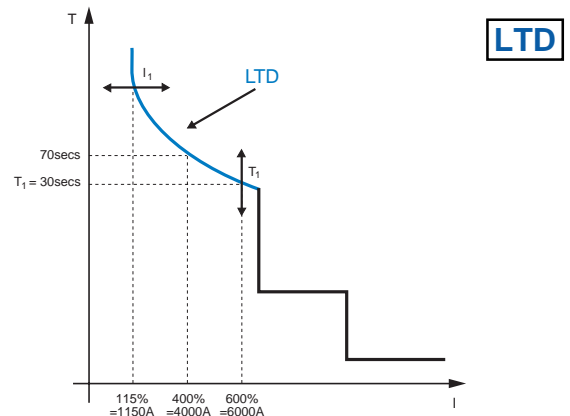

OCR Checker

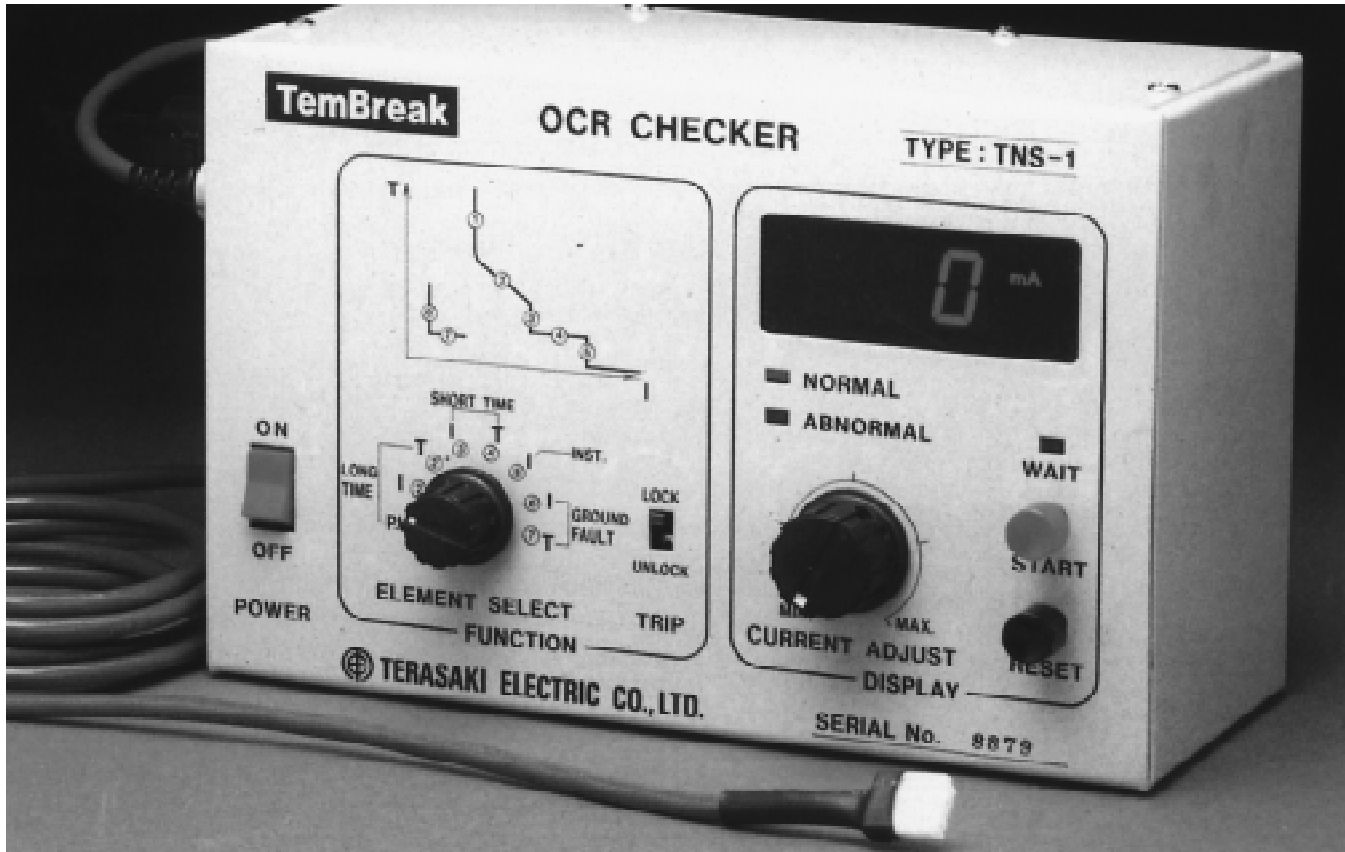

The TemBreak (Electronic) OCR Checker, is a portable easy-to-use instrument for field testing the trip functions.

It checks the pick-up current and tripping time values of the LTD, STD, INST and GFT functions.

Ratings and Specifications

Power Source	100-110V AC Single phase 50/60Hz TNS- 1/1 200-220V AC Single phase 50/60Hz TNS- 1/2
Power Consumption	30VA
Application	LTD function check (Set current and trip time values) STD function check (Set current and trip time values) INST function check (Set current value) GFT function check (Set current and trip time values)
Measurement of set current values	Display 3-digit digital display Range 0-900mA
Measurement of tripping time values	Range 0.00-99.9 seconds
Outline Dimensions	200mm (W) x 84mm (H) x 130mm (D)
Weight	2.7kg
Accessories	Power cord (3-core with grounding pole 2.4m one pc) Connecting cable 3m one pc.

Optional Accessories

47-83

5

• Internally mounted accessories	48-51
Overview	48
Connection diagrams and terminal numbers	49
Ratings	50
Combinations	51
• Externally mounted accessories	52-83
Overview	52-53
Motor operators	54-57
Earth leakage block & TemProtect	58-59
Handle operating mechanisms	60-69
Handle holder, handle lock and key lock	70
Interlocking solutions	71-73
Changeover pair	74
Terminal covers	75-76
Interpole barriers	77
Accessory lead terminal blocks	78-79
Door flange	80
Panel cut-out for OCR adjustment	81
Plug-in mounting blocks for distribution board	82-83

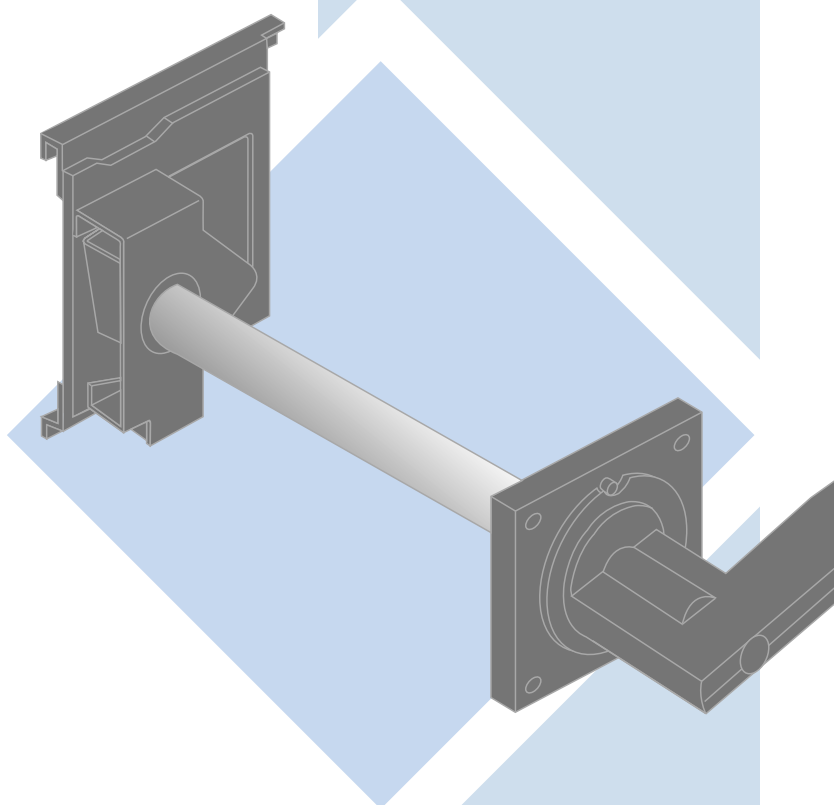

5

Optional Accessories

Internally Mounted Accessories

Overview

Shunt Trip (SHT)

Remote tripping of the breaker

Undervoltage Trip (UVT)

Automatically trips the breaker when the circuit breaker falls below pre-set value. Remote tripping of the breaker is also possible.

Note: The UVT controller is installed externally, when provided with AC UVT. (Refer to page 50)

Note: The SHT and UVT cannot be mounted in the same breaker.

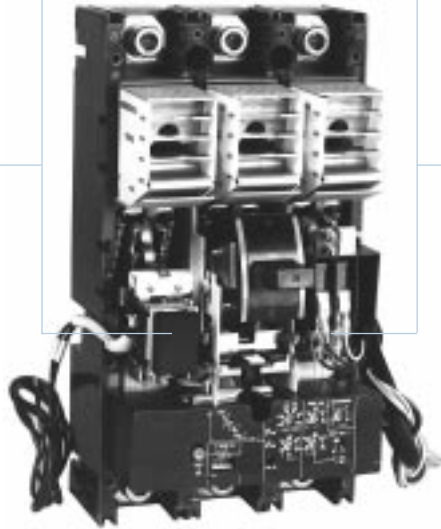

Auxiliary Switch (AX, AXE)

Electrically indicates On/Off status of the breaker.

Alarm Switch (AL, ALE)

Electrically indicates when the breaker is in the "Tripped" state.

Accessory lead terminal configurations (three types)

Integral lead (450mm)

•Applicable to front connected, rear connected and plug-in type breakers as standard features.

Lead specifications

Internal accessories	Type	Size	Finish O.D.	Colour
SHT	*Wire (1)	0.5mm ²	3mmØ	Black
UVT 225AF	*Wire		1.8mmØ	Black
400AF or larger			3mmØ	Black
AX, AXE			1.8mmØ	Grey
AL, ALE			1.8mmØ	Black

(1) *Heat resistant



Note: When breakers are installed in series left to right, distances must be considered in determining lead diameter.

Terminal block type (LTS, LTF)

Applicable to front connection, rear connection and plug-in type breakers as optional features. Standard terminal arrangements. (Refer to pages 78-79)

Lead terminal block



Auxiliary circuit terminal (auto coupling) type (LTP)

Applicable to plug-in breakers as a standard feature.

Auxiliary circuit terminal standard arrangements (Refer to Section 6, page 96)

Aux. circuit terminals

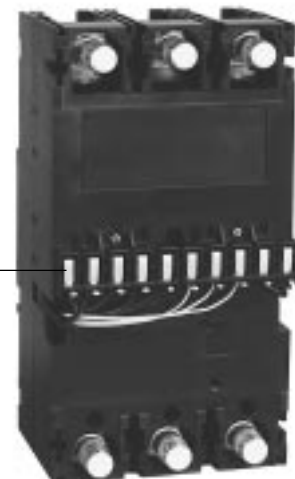

5

Optional Accessories Internally Mounted Accessories Connection Diagrams and Terminal Numbers

Shunt trip (SHT) No anti-burn switch	1P	3, 4P Provided with anti-burn switch	 With anti-burn switch	 Single pole (125AF) No anti-burn switch
Undervoltage trip (UVT)	3, 4P	AC rated voltage		
		DC rated voltage		
Auxiliary switch (AX, AXE)	3, 4P	No. of mountings		
		1 unit		
		2 units		
		3 units		
		4 units		
		5 units		
		6 units		
Alarm switch (AL, ALE)	3, 4P		 Not tripped	

Ratings of auxiliary switches (AX,AXE) and alarm switches (AL,ALE)

Applicable breakers		250AF or smaller			400AF or larger (including: XH250PE)			
Switch type		*AV39052(AXE, ALE)			*V-10(AX, AL)			
AC	Voltage (V)	480	250	125	480	250	125	
	Current (A)	Resistive load	0.4	3	3	3	5	5
		Lamp load	0.05	0.3	0.5	0.3	1.5	2
		Inductive load	0.25	2	2	2	5	5
		Motor load	0.1	0.5	0.7	0.4	2	3
DC	Voltage (V)	250	125	30	250	125	30	
	Current (A)	Resistive load	0.2	0.4	3	0.3	0.6	5
		Lamp load	0.03	0.05	1	0.05	0.1	3
		Inductive load	0.03	0.05	2	0.3	0.6	4
		Motor load	0.03	0.05	2	0.05	0.1	3

Note:* For use in the micro current (mA) range. Contact Terasaki for details.

Operation of AX, AXE and AL, ALE

Switch type	Breaker 'ON'	Breaker 'OFF'	Breaker 'TRIP'
AX, AXE			

Switch type	Breaker 'ON'	Breaker 'OFF'	Breaker 'TRIP'
AL, ALE			

5

Optional Accessories

Internally Mounted Accessories

Ratings

Shunt trip (SHT) rating

Series	Breaker	Rated voltage:	Exciting coil current [peak value (A)] Values at the highest voltage (60Hz for AC use)				
			110-115VAC	200-480VAC	24VDC	48VDC	100-115VDC
XE	XE100NS	3.4	0.83	1.6	0.71	0.4	—
	XE225NS	2.6	1.6	2.6	1.2	0.77	—
	XE400NS, XE600NS	1.1	0.93	2.52	1.55	0.67	0.35
XS	XS50NB	3.4	0.83	1.6	0.71	0.4	—
	XS125CJ, XS125NJ						
	XS160NJ, XS250NJ, XS250PJ						
	XS400CJ, XS400NJ, XS400SE-C	1.1	0.93	2.52	1.55	0.67	0.35
	XS400SE, XS630CJ						
	XS630NJ, XS630SE-C, XS630SE						
	XS800NJ, XS800SE						
XS1250SE, XS1600SE							
XH	XS2000NE	1.1	*0.4 (200-240VAC)	2.52	1.55	0.67	0.35
	XS2500NE		*0.93 (380-480VAC)				
	XH125NJ, XH160NJ, XH250NJ	3.4	0.83	1.6	0.71	0.4	—
XM	XH250PE, XH400SE	1.1	0.93	2.52	1.55	0.67	0.35
	XH630SE, XH800PS, XH800SE						
	XM30PB	3.4	0.83	1.6	0.71	0.4	—

Note: AC rated, permissible operating voltage range is 85 to 110%. DC 75 to 125%. Note: Special voltages available on request. Contact Terasaki for details.
 Note: *Applicable to 200V and 400V class only Note: Shunt trip is provided with anti-burnout switch.

Shunt trip (SHT) rating 1-Pole breaker only

Series	Breaker	Rated voltage:	Exciting coil current [peak value (A)] Values at the highest voltage (60Hz for AC use)	
			110-440VAC	48-250VDC
XS	XS125CS	2.99A	1.25	
	XS125NS	2.99A	1.25	

Note: AC rated, permissible operating voltage range is 85 to 110%. DC 75 to 125%. Note: 1-Pole breakers are not fitted with anti-burn-out switches (SHT).
 Note: Shunt trip supply must be fed from load side.

Undervoltage trip (UVT) ratings

Series	Breaker	Rated voltage:	Power supply, VA (with UVT controller)			Exciting coil current (mA)		
			100-120VAC	200-240VAC	300-450VAC	24VDC	100-115VDC	200-230VDC
XE	XE100NS	5VA	5VA	5VA	18.2	4.8	*—	
	XE400NS, XE600NS				22.7	6.0	*—	
	XS50NB, XS125CJ, XS125NJ, XS160NJ, XS250PJ				18.2	4.8	*—	
XS	XS400CJ, XS400NJ, XS400SE-C	5VA	5VA	5VA	22.7	6.0	*—	
	XS400SE, XS630CJ							
	XS630NJ, XS630SE-C, XS630SE							
	XS800NJ, XS800SE							
	XS1250SE, XS1600SE							
	XS2000NE, XS2500NE							
	XS1000ND							
XS1250ND, XS1600ND				26.0	9.2	*—		
XH	XH125NJ, XH160NJ	5VA	5VA	5VA	18.2	4.8	*—	
	XH250NJ							
	XH250PE, XH400SE				22.7	6.0	*—	
XM	XH630SE, XH800SE, XS800PS							
	XM30PB	5VA	5VA	5VA	18.2	4.8	*—	

Note: Tripping voltage is 35-70% of the rated voltage. Resettable voltage is 85% or less, of the rated voltage.
 Note: *200V DC application available on request as a special specification and equipped with resistor. Contact Terasaki for details.
 Note: Special voltages available on request. Contact Terasaki for details

UVT controller

If the UVT is for AC use a UVT controller must be installed. Standard installation of the UVT controller is on the left side of the breaker. However, this may be installed in a separate location (please specify). Separate installation is standard for breakers fitted with Mechanical Interlocks. A time-delay UVT controller is available with the same outside configurations (please contact Terasaki for details). For the mounting position of UVT controller, OCR controller and accessory lead terminal blocks, please refer to pages 42, 78 and 79.

Undervoltage trip (UVT) ratings

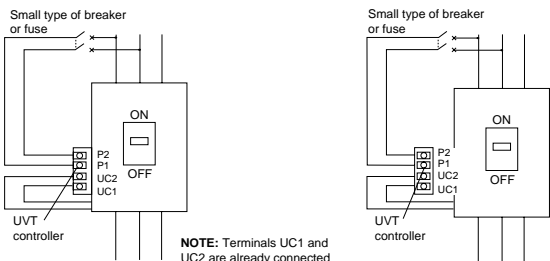

Controller Designations

Frame size	50A-250A	400A-2500A
Instantaneous type	XCU IS	XCU 4JS
Time delay type	XCU ID	XCU 4JD

UVT controller, outside configuration

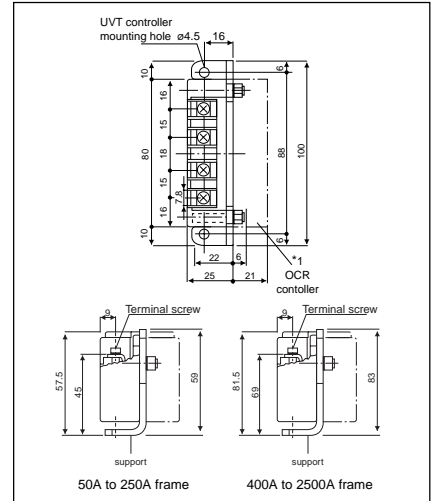

5

Optional Accessories Internally Mounted Accessories

Combinations of Internally Mounted Accessories

Breaker type

Breaker type	XE100NS	XE100NS XE225NS	XE400NS	XE600NS	
XE					
XS	XS50NB	XS50NB XS125CJ XS125NJ XS160NJ XS250NJ XS250PJ	XS400CJ XS400NJ XS400SE-C XS400SE	XS630CJ XS630NJ XS630SE XS800NJ XS800SE XS1250SE XS1600SE	XS2000NE XS2500NE
XH		XH125NJ XH160NJ XH250NJ *XM30PB	XH400SE	XH630SE XH800PS	
XM					
No. of poles	1	2	3,4	3,4	

Internally mounted accessories

AX,AXE					
AL,ALE					
SHT	**				
UVT					
AX,AXE AL,ALE					
AX,AXE SHT					
AX,AXE UVT					
AL,ALE SHT					
AL,ALE UVT					
AX,AXE AL,ALE SHT					
AX,AXE AL,ALE UVT					

Note: Accessory combinations are restricted when utilizing plug-in types. Please refer to page 96.

Note: * 3P only, UVT not available.

Note: ** Not fitted with anti-burn out switch.

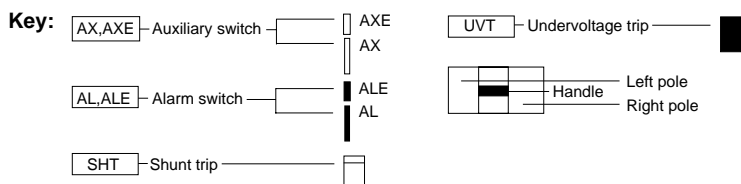

5

Optional Accessories Externally Mounted Accessories Overview

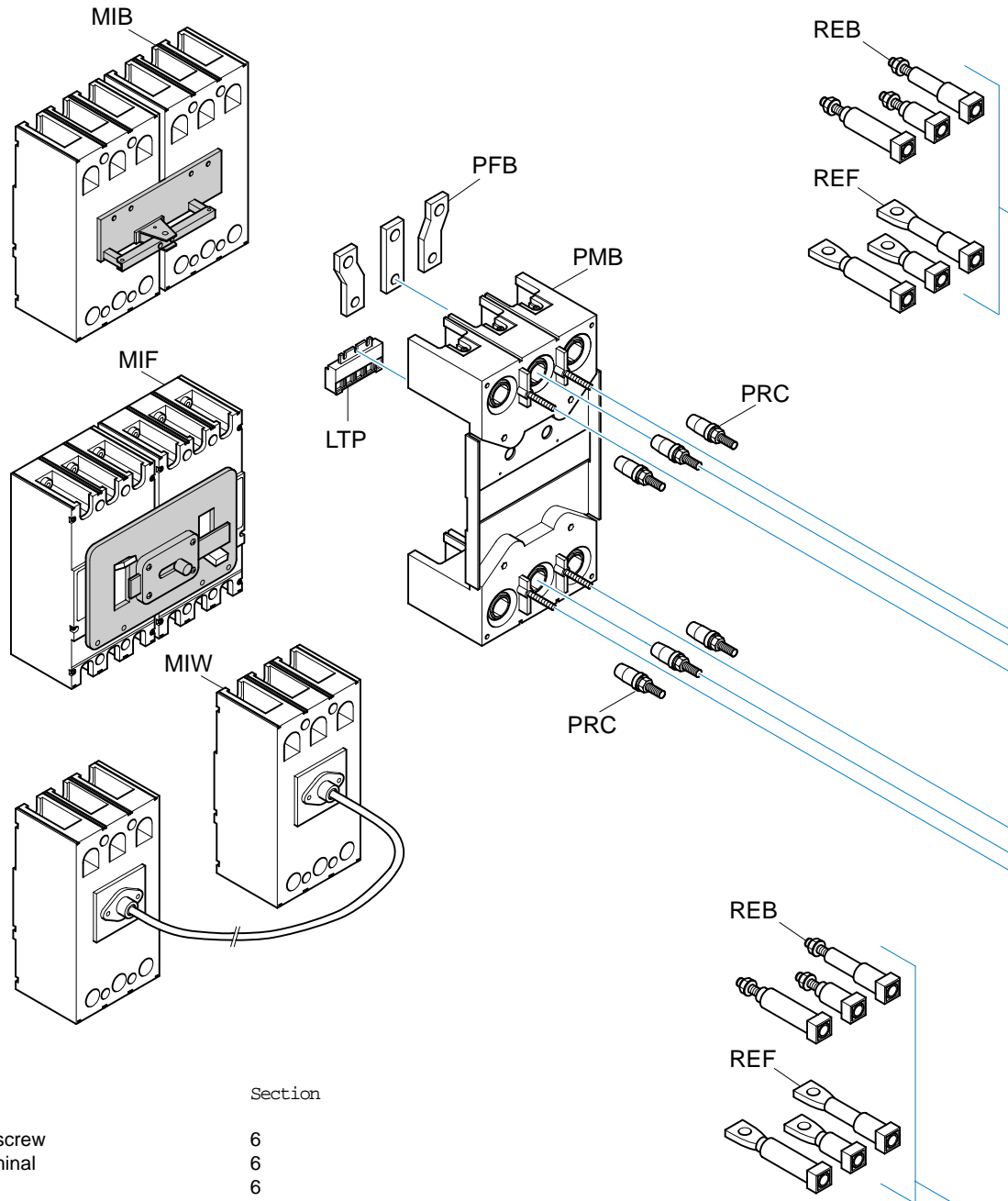

Designation	Description	Section
FCS	Front connect screw	6
PWC	Solderless terminal	6
BAR	Attach bar	6
REF	Rear connection flat bar	6
REB	Rear connection bolt stud	6
PRC	Plug-in rear connection	6
PFB	Plug-in attach bar	contact Terasaki
LTP	Plug-in lead terminal	6
LTF	Accessory lead terminal	5
LTS	Accessory lead terminal (angled entry)	5
PMB	Plug-in mounting base	6
TCF	Terminal cover (front connected)	5
TCR	Terminal cover (rear connected)	5
TBA	Interpole barrier	5
XCU	UVT controller	5
ELB	Earth leakage block	5
EHA	Extension handle	5
HL	Handle lock	5
MOT	Motor operator	5
OMM	Operating handle, variable depth	5
OHE	Operating handle, panel mounted	5
OHJ	Operating handle, breaker mounted	5
MIF	Front mechanical interlock	5
MIB	Rear mechanical interlock	5
MIW	Wire mechanical interlock	5

5

Optional Accessories Externally Mounted Accessories Overview

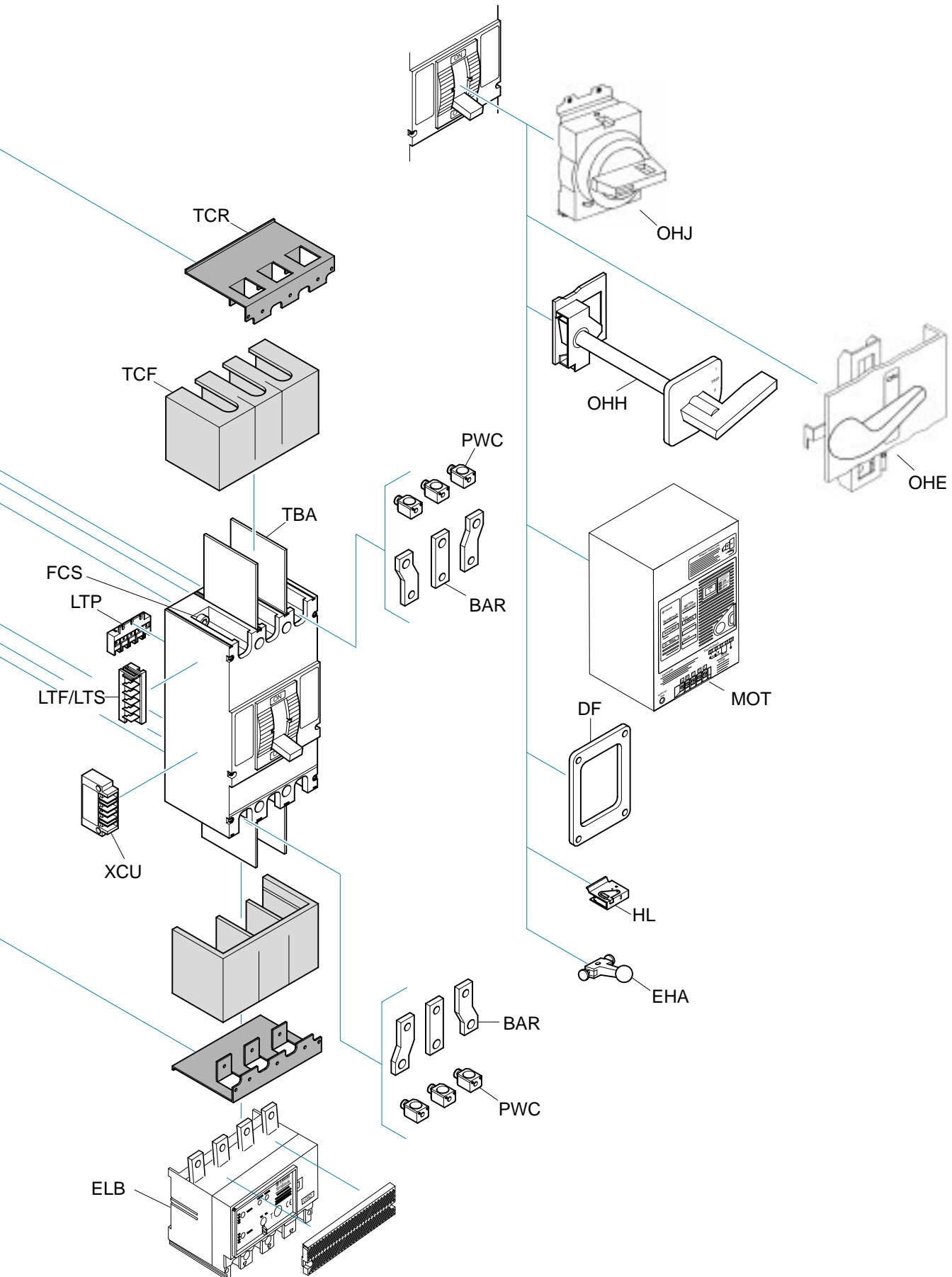

5

Optional Accessories

Externally Mounted Accessories

Motor Operators (MOT)

Motor driven types

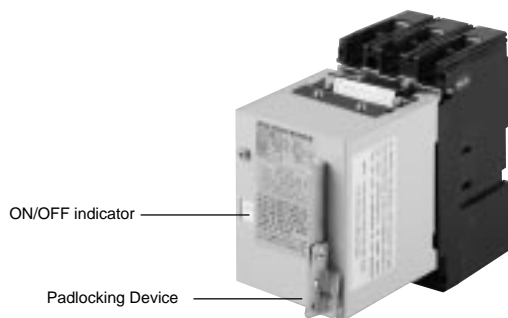

Motor driven type 1

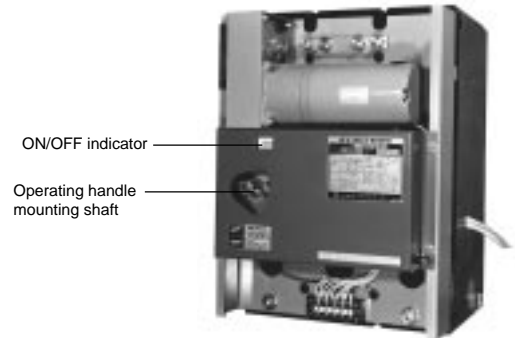

Motor driven type 2

Ratings and specifications

Applicable breakers	XE Series	XE100NS, XE225NS	–
	XS Series	XS50NB, XS125CJ, XS125NJ XS160NJ, XS250PJ, XS250NJ	XS2000NE XS2500NE
Operating voltage ①	XH Series	XH125NJ, XH160NJ, XH250NJ	–
		AC100, 110V 200, 220V DC100, 110V	• • ⑦
Automatic Reset	Yes	•	•
	No	•	•
Steady-state r.m.s. amp/inrush amp (A)	⑤ AC100	50Hz	2.0
		60Hz	4.5
	⑥ AC200	50Hz	1.0
		60Hz	2.0
⑦ DC100V	110V	⑦	
		⑦	
Operator Type		Motor driven type 1	Motor driven type 2
Operating Time(s)	ON	1.0	2.0
	③ ④ OFF, RESET	0.85	1.6
Control switch ratings		250V, 5A	250V, 5A
Power source capacity (VA)		100	300
Withstand voltage		AC1000V	AC1000V
Weight (kg)		1.8	17

Note: •: Yes or available,
–: No or not available

Reference Notes

- ① Permissible operating voltage range as follows:
AC rated, 85 to 110% of the rated voltage
DC rated, 85 to 110% of the rated voltage
Note: AC rated operating voltage 380V or 400-460V a power transformer is available (optional)
- ② Requires breaker's auxiliary switch (1b-contact). This will be wired at the factory (on request) when the breaker/motor operator assemblies are ordered. However, when all the auxiliary switch contacts are specified for other purposes, an external auxiliary relay (not supplied) is required to be controlled by the auxiliary a-contact of the breaker and use the relay's normally closed contact (b-contact) for automatic reset.
- ③ Time values at the rated operating voltage. Allow a longer time for the motor operator to complete the operation, at lower operating voltage.
- ④ The motor operator is of a short time duty. Do not subject it to more than 10 continuous ON-OFF operations. If this occurs, allow the motor operator to cool for at least 15 minutes.
- ⑤ Maximum values at 110V AC
- ⑥ Maximum values at 220V AC
- ⑦ Special specification, available on request.

Operating Procedures for Motor Driven Type (1)

Motor Operation

ON Control

Operating the ON switch energises the motor which turns ON the breaker. When the breaker is energised the limit switch operates to de-energise the motor.

Note: This is not a self-holding type. Gives a signal exceeding the operating time.

OFF Control

Operating the OFF/RESET switch energises the motor which turns OFF the breaker. When the breaker is energised the limit switch operates to de-energise the motor.

Note: This is not a self holding type. Gives a signal exceeding the operating time.

RESET Control

Operate the OFF/RESET switch to reset the tripped breaker. When the breaker is reset (OFF) the limit switch operates to de-energise the motor.

Note: This is not a self holding type. Gives a signal exceeding the operating time

Automatic Reset (Optional)

The automatic reset feature can be incorporated by adding the breaker's auxiliary switch contact (b-contact) in parallel with the OFF/RESET control switch.

Note: When the cause of the trip has not been removed the ON-TRIP-RESET-ON operation is repeated. Therefore, do not use the ON operation switch which is normally closed.

Manual Operation

To operate the mechanical test facility of the motor operator pump the manual lever left and right approximately 20 times.

Note: This facility **must not** be used for ON load operations.

Lock in OFF position

The breaker can be padlocked in the OFF position. (padlock not supplied).

CAUTIONARY NOTES

If the motor operator is turned ON with the breaker OFF and the UVT de-energised, apply the power and complete one ON-OFF operation. (The breaker cannot be turned ON). Then complete one ON operation again (The breaker can be turned ON)

When the breaker is ON and is then tripped, the ON/OFF indicator on the motor operator will be indicating ON until the breaker is reset.

Note: The breaker's condition may differ.
Note: Allow several minutes to cool when a thermal-magnetic breaker is tripped by a thermal overload trip, then reset the breaker.

5

Optional Accessories Externally Mounted Accessories Motor Operators (MOT)

Operating procedures for motor driven type (2)

Motor operation

'ON' control

Operating the ON switch energises the relay (X) via the motor switch 2-3 (closed). This in turn energises the motor, which turns the breaker ON. When the breaker is ON, the motor switch is thrown to the other side resulting in the relay (X) de-energising and stopping the motor.

'OFF' control

Operating the OFF/RESET Switch energises the relay (Y) via the motor switch 1-2 (closed). This in turn energises the motor which turns the breaker OFF. When the breaker is OFF the motor switch is thrown to the other side resulting in the relay (Y) de-energising and stopping the motor.

"RESET" control

Operate the OFF/RESET Switch to reset the tripped breaker. Circuit operation is the same for the OFF Control procedures.

Automatic reset (Optional)

The automatic reset feature can be incorporated by connecting the breaker's auxiliary switch contact (b-contact) in parallel with the OFF/RESET control switch.

Manual operation

Position the manual handle (supplied with motor operator) onto the motor operator shaft. Turn the handle anti-clockwise to turn the breaker OFF or RESET. During manual operation (by handle) the motor operator shaft is disengaged from the mechanism. Removing the handle automatically engages the shaft with the motor operator mechanism.

Handle switch

With the addition of a handle switch, the motor operator mechanism can be automatically brought to the manually operated position (ON or OFF) on removal of the handle, providing that the motor operator is powered up.

CAUTIONARY NOTES

When the breaker is ON and is then tripped, the ON/OFF indicator on the motor operator will indicate ON until the breaker is reset.

Note: The breaker's condition may differ.

Control circuit

Motor driven type (1)

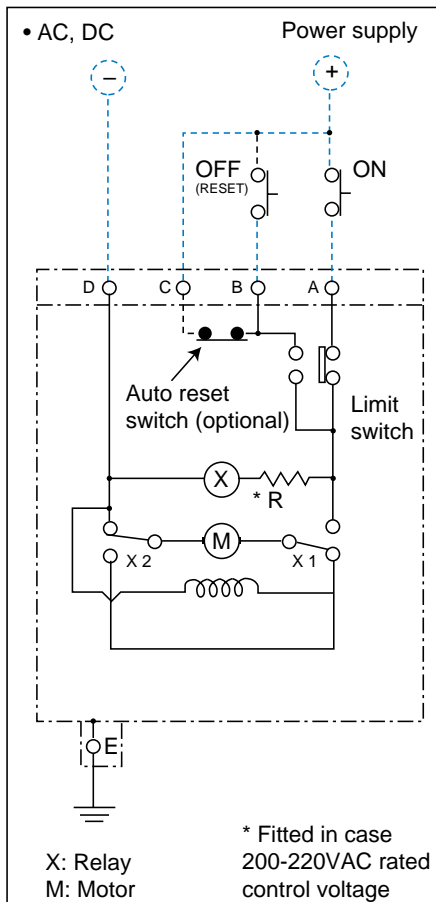

Note:

Customer wiring shown in blue

Motor driven type (2)

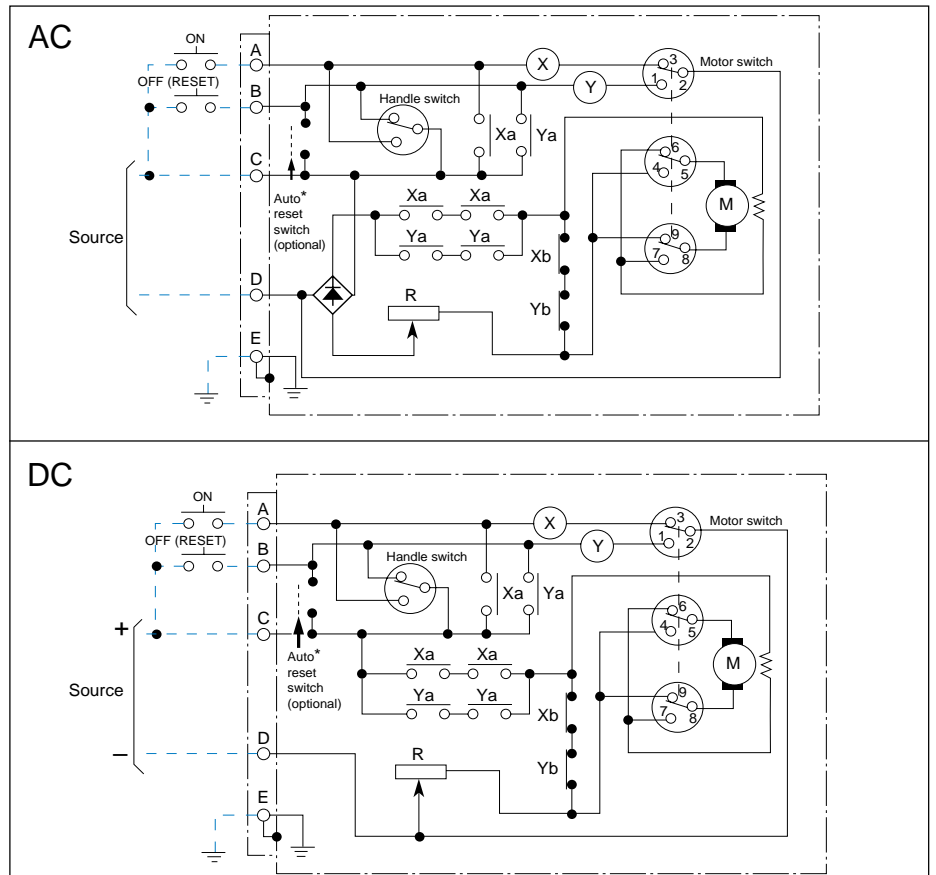

Note: *External to motor operator
Customer wiring shown in blue

5

Optional Accessories

Externally Mounted Accessories

Motor Operators (MOT)

NEW Spring Charged Types

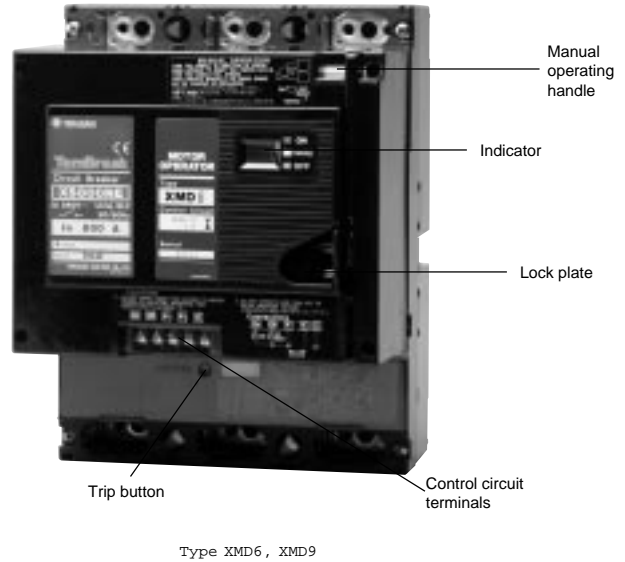
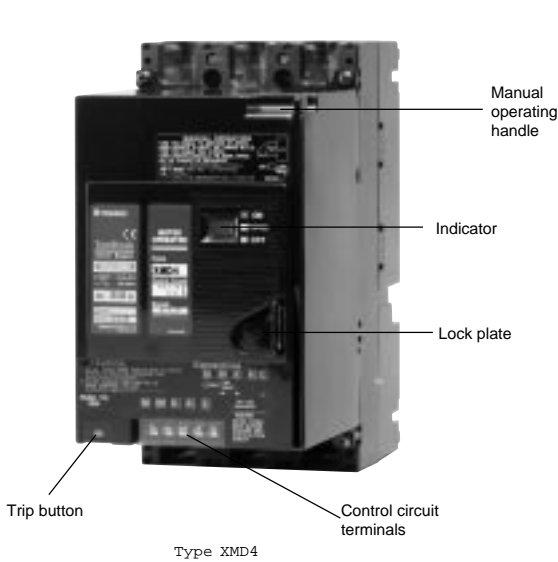

Positive contact indication

Colour coding indicates the true position of the contacts clearly: ON (red), OFF (green), TRIP (white).

Easy maintenance

Breaker mounting, removal, and even setting changes can be done without removing the motor operator.

Availability

XMD6, XMD9 available now. XMD4 available by the end of 2003. Until then the XMC motor operator will be supplied for 400AF. Please refer to catalogue '98-T20E for XMC information.

Manual ON/OFF operation with one stroke

Lever pumping is no longer required.

Fast closing operation

Closing in 60ms or less. The closing time remains constant over repeated operations.

Ratings and Specifications

Type of Motor Operators	XMD4	XMD6	XMD9
Applicable Breakers	XE Series XS Series	XE600NS XS630CJ XS630NE XS630NJ XS800NJ XS630CE XS800NE XS1000ND	XS1250NE XS1250ND XS1600NE XS1600ND
	XH Series	XH250PE XH400NE XH630NE XH800PS XH800NE	
Rated Operating Voltage (V)	AC 100-115V 50/60Hz 200-230V 50/60Hz DC 100-110V 24V	• • • • • •	• • • • • •
Lock in "OFF" position (standard)	•	•	•
Manual Trip Button	•	•	•
Steady-state r.m.s. Amp/inrush Amp (A)	AC100 ON ① -115V OFF, RESET ① AC200 ON ② -230V OFF, RESET ② DC100 ON ③ -110V OFF, RESET ③ DC24V ON OFF, RESET	-/3.1 1.2/5.7 -/1.2 0.7/3.0 -/0.8 1.0/4.0 -/4.5 4.0/12.0	-/3.1 1.8/6.0 -/1.2 1.0/3.2 -/0.8 1.1/4.2 -/4.5 4.0/12.0
Type of operation	Spring Charged	Spring Charged	Spring Charged
Operating Time(s)	ON (Maximum values) OFF, RESET ④	0.06 3	0.06 3
Control Switch Ratings	250V, 5A	250V, 5A	250V, 5A
Power Source Capacity (VA)	300VA	300VA	300VA
Dielectric withstand voltage	AC1500V (AC500V)	AC1500V (AC500V)	AC1500V (AC500V)
The value in brackets for 24V DC			
Weight (kg)	4.7	5.6	6.4

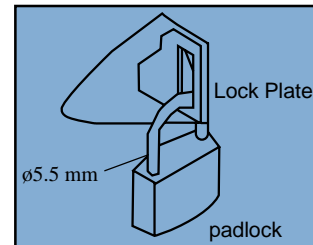

The breaker can be padlocked in the "OFF" position by pulling out the lock plate, and locking it with a padlock. When the breaker is "ON", the lock plate cannot be pulled out. Up to three locks can be used. Padlocks not supplied.

NOTE

- : Yes or available
- ① : Maximum values at AC115V, 50Hz
- ② : Maximum values at AC230V, 50Hz
- ③ : Maximum values at DC110V
- ④ : Maximum values at the rated operating voltages

* Trip button on breaker to be used (accessible with motor fitted)

5

Optional Accessories

Externally Mounted Accessories

Motor Operators (MOT)

Motorised operation

ON CONTROL

When the ON switch is closed, the latch release coil (LRC) is excited and the closing spring is released. The breaker quickly closes and goes into ON status. When the closing spring is released, the limit switch (LS) is opened and the LRC is de-excited.

OFF CONTROL

When the off switch is closed, self-hold control relay (Y) is activated and motor (M) operates to charge the closing spring. The breaker changes to OFF status.

RESET CONTROL

When the breaker is in TRIP status, closing the OFF switch activates self-hold control relay (Y) and starts motor (M). Motor (M) charges the closing spring and resets the breaker.

Manual operation

ON, OFF (RESET)

The breaker can be opened (OFF or RESET) and closed (ON) alternately by pulling the operating lever down in one full stroke. ON/OFF operation of the breaker is possible without charging or releasing the closing spring.

TRIP

The breaker can be tripped by pushing the TRIP button on the motor operator of type XMD4. (For XMD6 and XMD9, use the Trip button of the breaker)

Emergency Trip

Opening the breaker (OFF) using the motor operator takes up to 3 seconds. If a remote emergency OFF function is necessary, incorporate the shunt trip device (SHT) or the undervoltage trip device (UVT) into the breaker.

PRECAUTIONS REGARDING USAGE

- If using the UVT option, be sure to reset the UVT before closing the breaker.
- The motor operator must be supplied with voltage within the following range:
DC: 75-110% of rated voltage
AC: 85-110% of rated voltage
Operation at low voltage may burn out the motor.

Anti-pumping function

When the breaker is turned ON and the closing spring is released, self-hold control relay X is activate. Xa-contact is held closed, and Xb-contact is opened. While the ON switch is closed, latch release coil (LRC) will not be excited even if the OFF switch is closed or an automatic reset circuit is being used. Pumping is thus prevented.

Automatic charge/discharge function

If the breaker is closed manually (ON) while the power source is on, the handle switch (HS) induces automatic release of the closing spring. Likewise, if the breaker is opened manually (OFF), the springs are automatically charged. If the breaker is opened or closed while the power source is off, later when the power source is turned on, the closing spring will automatically be charged or discharged to match the ON/OFF status of the breaker. This automatic charge/discharge function is necessary to prepare the closing mechanism for the next ON/OFF operation. The sound of the charging or discharging of the spring should not be mistaken for a malfunction.

Automatic reset

An alarm switch (a-contact) fitted in the breaker, can be used to induce recharging of the closing spring and automatically reset the MCCB. Connect the automatic reset circuit as shown below.

It is recommended that a time delay of approximately 3 minutes is introduced to the automatic reset circuit for thermal magnetic MCCB's. In the event of an overload trip this will prevent the motor operator repeatedly driving the MCCB between the tripped and reset positions while the thermal element is hot.

If an alarm signal is also required for external control, use a 2 alarm switch combination, as shown on page 51, columns 4 & 5.

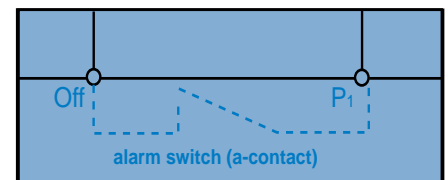

Control circuit AC and DC

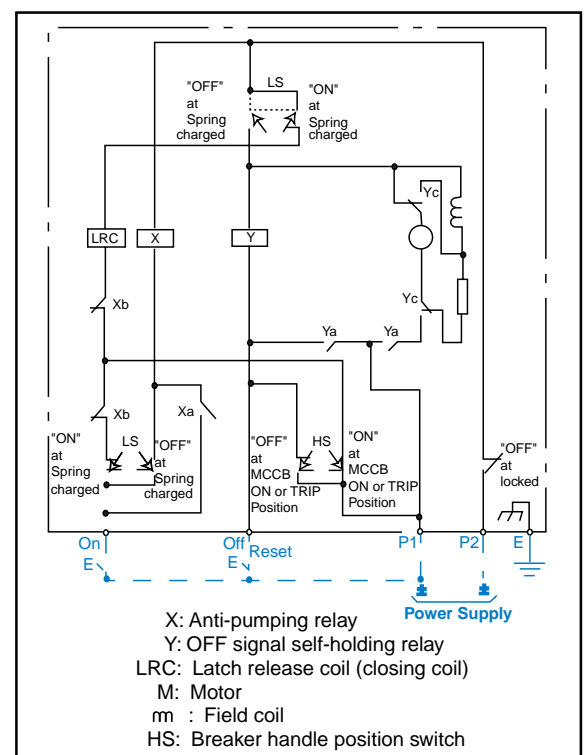

Note: Customer wiring shown in blue

5

Optional Accessories

Externally Mounted Accessories

Earth Leakage Block (ELB)

NEW



Introducing advanced earth leakage protection for Teraski's range of compact MCCBs. Designed as a space saving module, the earth leakage block adds comprehensive personnel and equipment protection to the impressive current limiting abilities of the TemBreak 125A and 250A range of MCCBs. Manufactured to the highest degree of quality the earth leakage block is fully compliant with all relevant national and international standards as well as satisfying all EMC requirements, giving protection you can rely on.

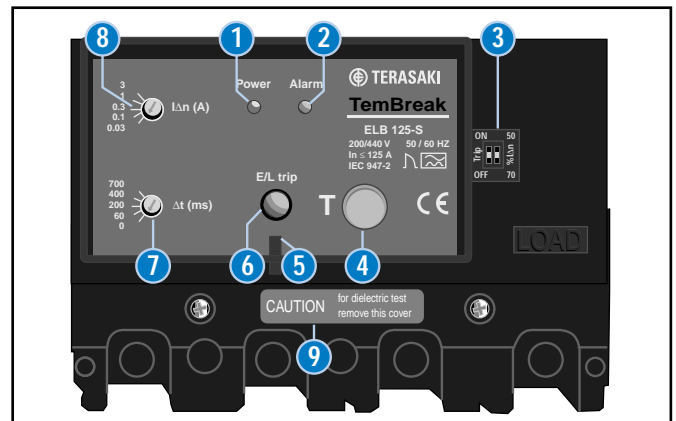

1. Power indication LED (Green)
 2. *Local pre-trip alarm indication LED (Red)
 3. *Trip/Non-Trip and alarm current sensitivity dip switches
 4. Test push button
 5. Front cover sealing point
 6. Mechanical trip indication
 7. Time delay setting dial
 8. IΔn residual current setting dial
 9. Dielectric test disconnect cover
- Note *Available on ELB - A only

Available in two models.

The ELB-S (standard) offers very flexible current sensitivity and time delay settings, as well as visual indication of voltage presence and earth leakage trips.

The ELB-A (advanced) incorporates all the functions of the ELB-S, and additionally provides:

- An early warning system with pre-trip current sensitivity adjustment
- Trip/non trip selector switch for early warning system
- Volt free output contact for early warning system.

Type		ELB-S	ELB-A
Applicable breakers	125 AF 250 AF (2)	YES YES	YES YES
RATINGS			
Current sensitivity	0.03	⊙	⊙
IΔn (A)	0.1	⊙	⊙
(adjustable)	0.3	⊙	⊙
	1.0	⊙	⊙
	3.0	⊙	⊙
Operating voltage	200-440V AC	⊙	⊙
Operating frequency	50/60 Hz	⊙	⊙
FEATURES			
Visual trip indication		⊙	⊙
Push-Button test		⊙	⊙
Pick-Up LED		-	-
Pre-Trip alarm contact (3)		-	⊙
Trip/Non-Trip function (4)		-	⊙

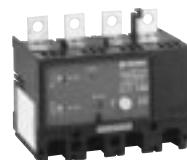

Note: ELB units are factory fitted to the required MCCB.

- ⊙ : Standard. This configuration is used unless otherwise specified.
 - ⊖ : Optional. Specify when ordering.
 - : Yes or available
 - : No or not available.
- (1) : Internal Diameter 35mm, 60mm, 80mm or 110mm
 - (2) : Please specify whether for use with XS250NJ or XH250NJ
 - (3) : Set at 50% or 70% IΔn by dip-switch
 - (4) : Set by dip-switch

5

Optional Accessories

Externally Mounted Accessories

Earth Leakage Block ELB & TemProtect E.L.R.

ELB-S and ELB-A Dimensions

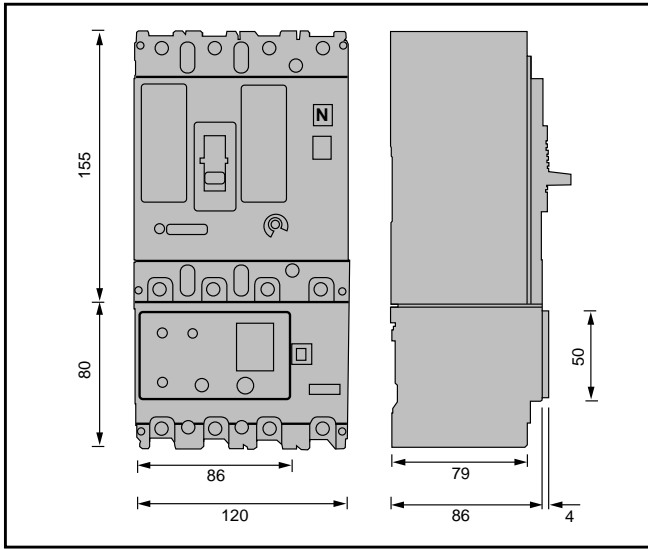

125AF

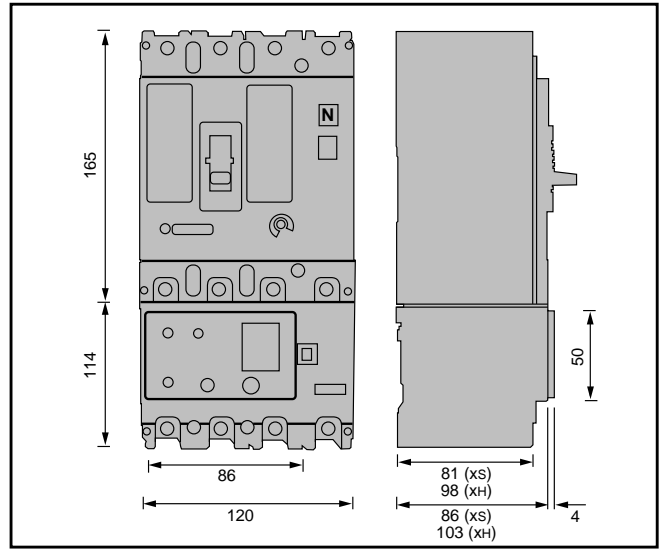

160/250AF

TemProtect Earth Leakage Relays



ELR-1 Range
Standard Earth Leakage
Range



ELRC-1
Combined Earth Leakage Relay and
Current Transformer Toroid



ELR-3C
Compact DIN rail mounting
Earth Leakage Relay

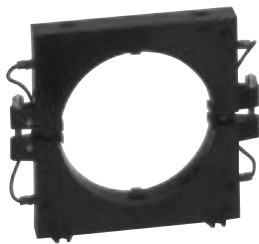

CTA-1 Range
Toroidal Current Transformer

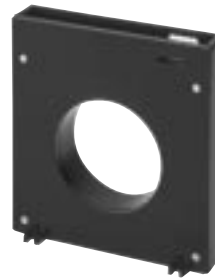

CT-1 Range
Toroidal Current Transformer

Owing to the wide range of applications for the use of earth leakage protection, TemProtect has been designed to be as flexible as possible. The range includes relays suitable for installations with DIN rail, Panel or Base Mounting. All relays are suitable for use on a.c. systems and will be unaffected by d.c. components which may be present.

The space saving ELRC-1 combined relay and current transformer provides further design options.

The relays filter circuit inputs to safeguard against external disturbances in the system and offer the additional advantage of integral Test and Reset buttons, as well as integral Indication of Power and Trip.

All the Earth Leakage Relays which have separate toroidal transformers constantly monitor the connection to the toroid and will trip should an open circuit occur. They also offer the choice of automatic, manual or remote resetting after a fault has occurred.

All the relays comply to international standards including IEC 255.

Please refer to page 22 for specifications, and catalogue '97-163E for more information.

5

Optional Accessories

Externally Mounted Accessories

Handle Operating Mechanism, Panel Mounted Type (OHE)

This is used when the breaker is installed in a control centre/switchboard or when it is required to be manually operated from the outside of the door.

Panel lock

This enables the door(s) of the control centre / switchboard to remain closed.

Note: Terasaki recommend provision should be made for a hook holder (not supplied). Refer to figure 2).

Panel/lock release (refer to Figure 1)

When the release knob is turned clockwise the door can be opened with the handle in any position (ON/OFF or TRIP).

Handle lock (refer to Figure 1)

The external operating handle can be locked (padlock not supplied) to prevent unauthorised switching (ON and OFF) of the handle.

Operation

ON - Turn the handle anti-clockwise to the ON position on the indication plate.

OFF - Turn the handle clockwise to the OFF position on the indication plate.

RESET

When the breaker trips, the handle indicates TRIPPED. Turn the handle clockwise to the RESET position. This will reset the breaker.

Opening the panel

Turn the handle clockwise to 'OPEN COVER'. The lock is released and the panel can be opened.

Colour of handle: Black

Ordering

Specify the panel mount and position indication plate types (refer to Table 1).

Panel mount: XFE21 Indication plate 1B-B-NP (example)

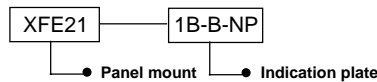
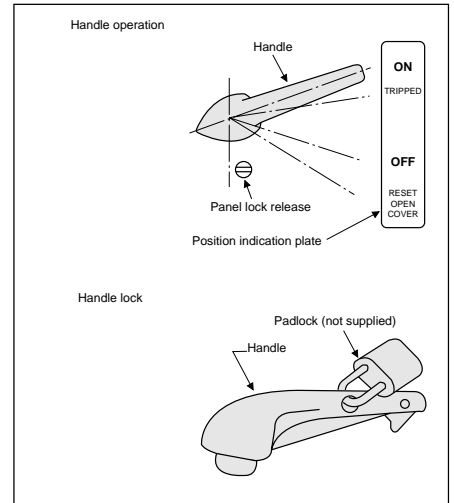
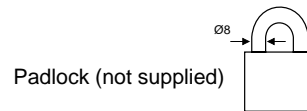

Figure 1



Note: Panel lock release knob and padlock are not supplied.



5

Optional Accessories

Externally Mounted Accessories

Handle Operating Mechanism, Panel Mounted Type (OHE)

Outline dimensions (mm). Types : XFE2-6

Figure 2

ASL : Arrangement Standard Line

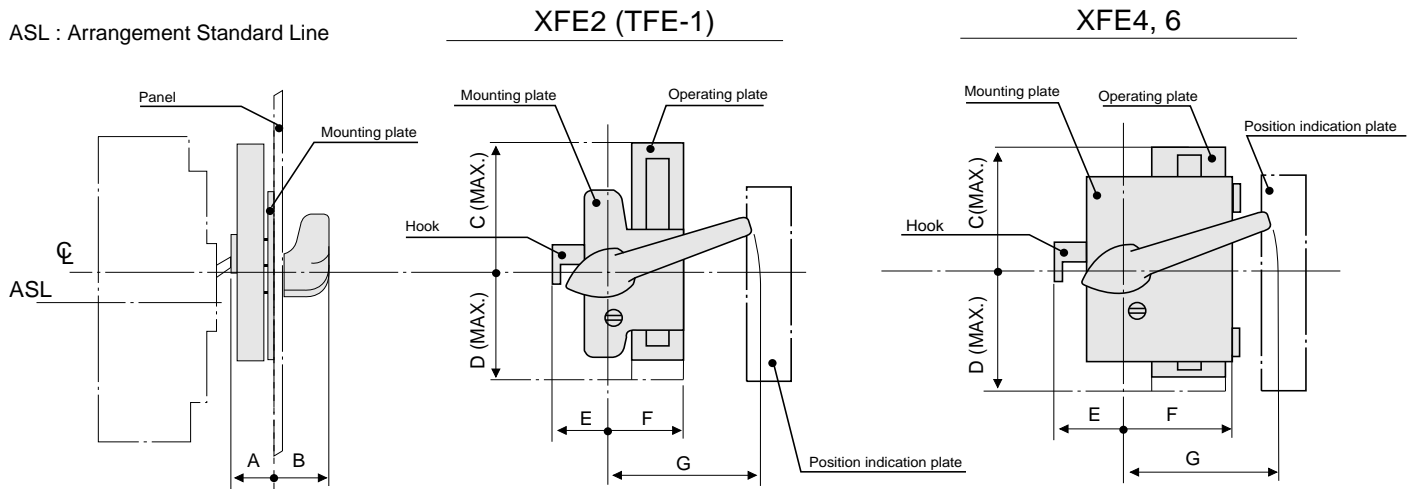

Mounting dimensions

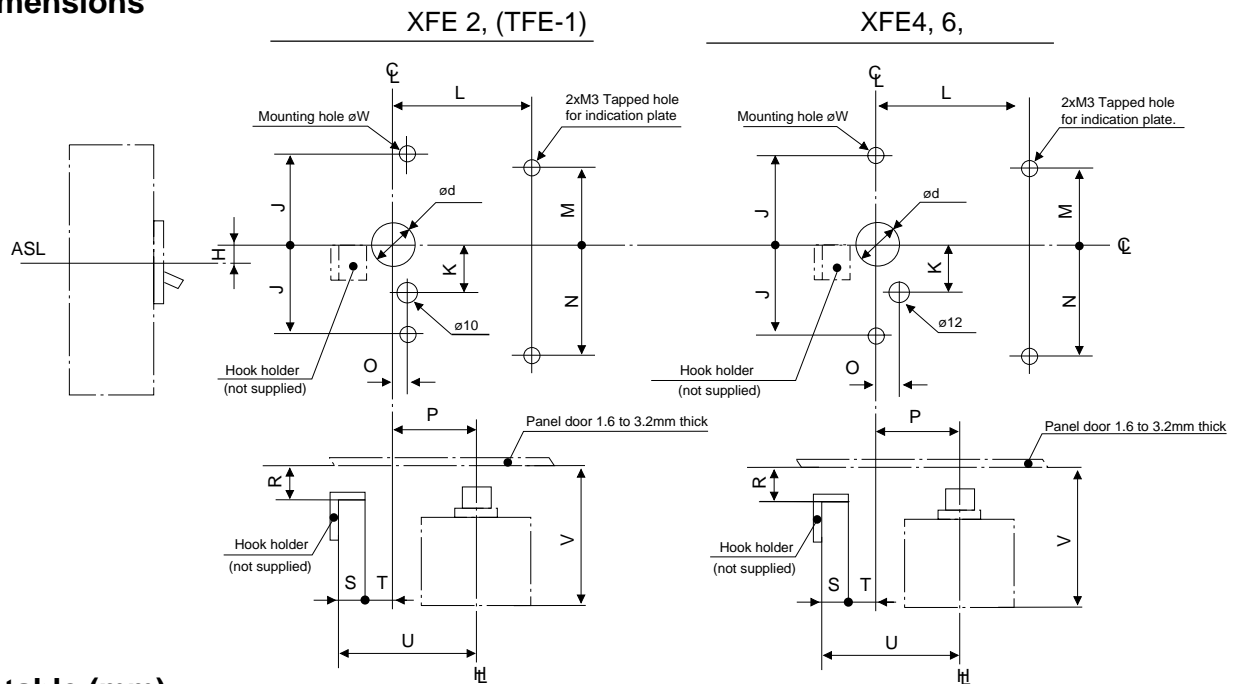

Dimensions table (mm)

Table 1

Frame (A)	Breaker	Op. handle	Ind. plate	d	A	B	C	D	E	F	G	H	J	K	L	M	N	O	P	R	S	T	U	V	W
30	XM30PB	XFE21	1B-B-NP	24	27.5	40	89	103	35	56.6	100	5	50	27	110	58	58	5	35	12.5	12	28	75	134	6
50	XS50NB	XFE21	1B-B-NP	24	27.5	40	89	103	35	56.6	100	5	50	27	110	58	58	5	35	12.5	12	28	75	104	6
100	XE100NS	XFE21	1B-B-NP	24	27.5	40	89	103	35	56.6	100	5	50	27	110	58	58	5	35	12.5	12	28	75	104	6
125	XS125CJ, XS125NJ	XFE22										3													122
225/250	XE225NS	XFE22	3X-A-NP	24	27.5	40	89	103	35	56.6	100	2.5	50	27	110	58	82	5	35	12.5	12	28	75	122	6
	XS160NJ, XS250NJ																								139
	XH125NJ																								
	XH160NJ																								
	XS250PJ																								
	XH250NJ																								
	XH250PE	XFE4	4X-A-NP	27	35.6	40	112	122	50	80.8	130	8	60	30	110	58	82	10	50	18.5	15	40	105	152	8
400	XE400NS, XS400CJ	XFE4	4X-A-NP	27	35.6	40	112	122	50	80.8	130	8	60	30	110	58	82	10	50	18.5	15	40	105	152	8
	XS400SE-C, XS400SE																								
	XS400NS, XH400SE																								
600	XE600NS, XS630CJ	XFE6	4B-A-NP	40	47.4	58	142	142	60	105	130	8	70	35	140	70	105	10	60	18.5	15	50	125	168.9	12
	XS630NJ, XS630SE-C																								
	XS630SE, XH630SE																								
800	XS800SE, XH800PS	XFE6	4B-A-NP	40	47.4	58	142	142	60	105	130	8	70	35	140	70	105	10	60	18.5	15	50	125	168.9	12
	XS800NJ, XH800SE																								
1250	XS1250SE	XFE6	4B-A-NP	40	47.4	58	142	142	60	105	130	12	70	35	140	70	105	10	60	18.5	15	50	125	199.4	12
1600	XS1600SE	XFE6	4B-A-NP	40	47.4	58	142	142	60	105	130	12	70	35	140	70	105	10	60	18.5	15	50	125	219.4	12

5

Optional Accessories

Externally Mounted Accessories

Handle Operating Mechanism, Panel Mounted Type (OHE)

Operation Type XFE 10

ON

Turn the handle clockwise to the 'ON' position on the indication plate.

OFF

Turn the handle anti-clockwise to the 'OFF' position on the indication plate.

RESET

When the breaker trips, the handle indicates tripped. Turn the handle anti-clockwise to the RESET position. This will reset the breaker.

OPENING THE PANEL

Turn the handle anti-clockwise to 'OPEN COVER'. The lock is released and the panel can be opened.

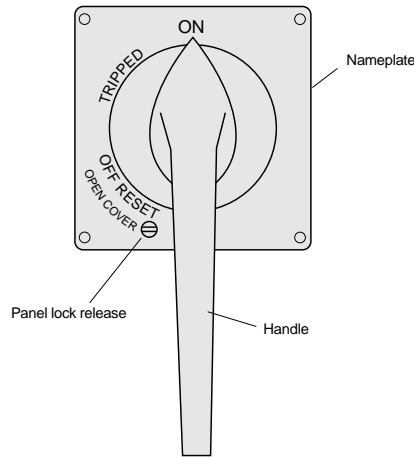

Outline Dimensions (mm) (Breaker types XS2000NE, XS2500NE)

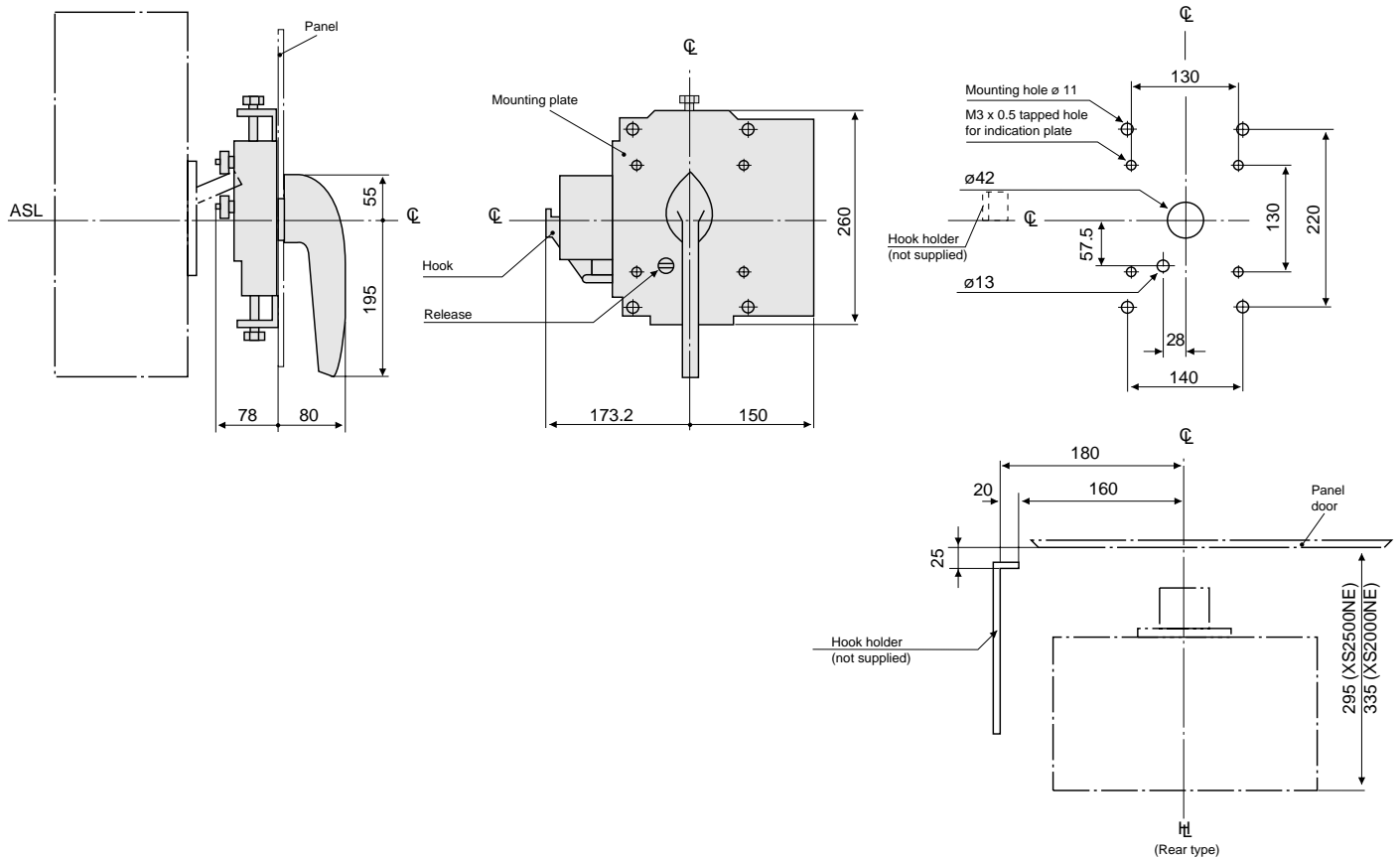

5

Optional Accessories

Externally Mounted Accessories

Handle Operating Mechanism, Breaker Mounted Type (OHJ)

90° ON/OFF OPERATION.

The handle operation and ON/OFF indicator are the same irrespective of the breaker mounting direction, being vertical or horizontal. This also applies to the panel cut-out.

Double insulation structure

Provides an even higher degree of safety.

Panel lock mechanism

The panel door cannot be opened when the handle is in the ON or OFF position. The panel door can only be opened in the RESET position.

- Equipped with a lock (reverse interlock) mechanism which does not permit the breaker to be closed while the panel door is opened. The lock can be released.
- When the panel lock release is turned counterclockwise the panel door can be opened even when the handle is in the ON or OFF position.

Handle Lock Mechanism

The handle can be locked in the ON or OFF position. Upto 3 padlocks can be fitted (padlock not supplied).

Ordering code

Please specify the correct type code when ordering (refer to Figure 3).

TFJXX - U

Mounting Direction	
U	Upper power supply
L	Left hand power supply
R	Right hand power supply

Additional Options

Please specify at the time of ordering

	Standard	Option
Colour	Black	Yellow base Red handle
IP	3X	55

Figure 3

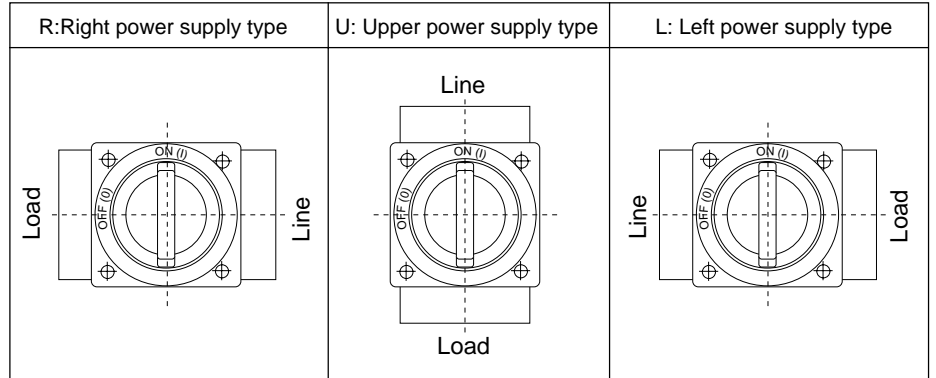

5

Optional Accessories

Externally Mounted Accessories

Handle Operating Mechanism, Breaker Mounted Type (OHJ)

Outline dimensions (mm)

TYPE TFJ-2

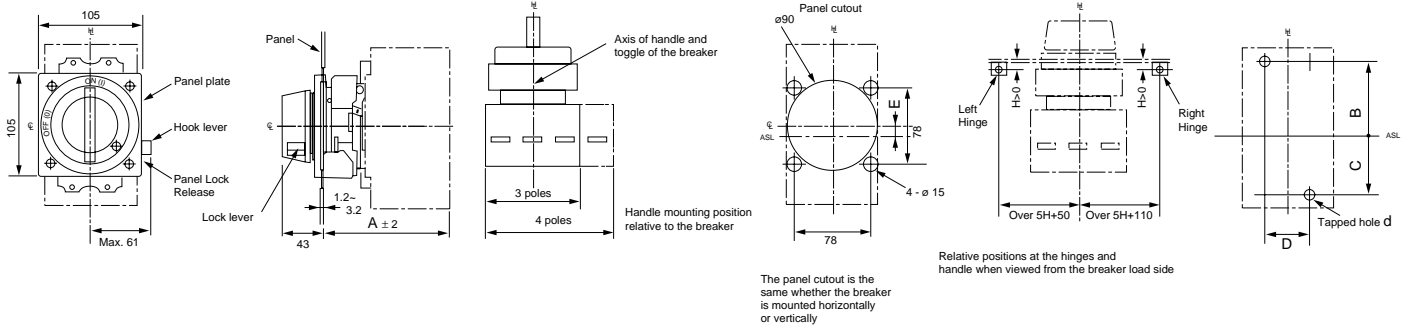

TYPE TFJ-3

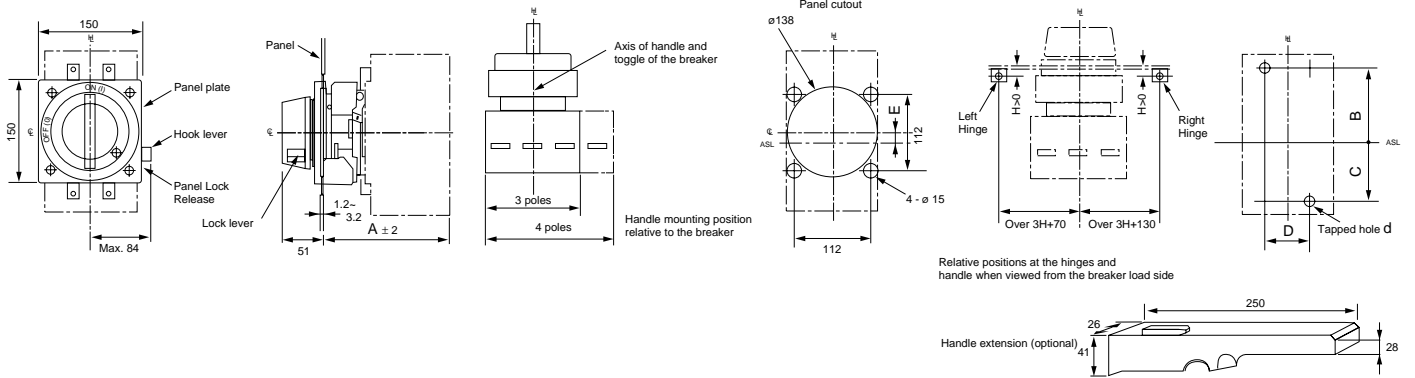

Dimensions table (mm)

Frame (A)	Breaker	No. of poles	Op. handle	A	B	C	D	d	E
30	XM30PB	3	TFJ21XPB	136	57.5	57.5	25	M4	0
50	XS50NB	3	TFJ21B	106	55.5	55.5	25	M4	0
100/125	XE100NS	3	TFJ21XH	106	55.5	55.5	25	M4	0
	XS125CJ	3,4	TFJ22X	124	66	66	30	M4	0
	XS125NJ								
	XH125NJ								
160/225/250	XE225NS	3	TFJ23XS	130	63	63	35	M4	0
	XS160NJ	3,4							
	XS250NJ								
	XH160NJ	3,4	TFJ23XH	147					
	XS250PJ								
400	XH250NJ								
	XH250PE		TFJ34X	157	107	107	45	M6	0
	XE400NS	3	TFJ34X	157	107	107	45	M6	0
	XS400CJ	3,4							
	XS400NJ								
	XS400SE-C								
600/630	XS400SE								
	XH400SE								
	XE600NS	3	TFJ36X	168	126	117	70	M8	+4.5
	XS630CJ	3,4							
	XS630NJ								
	XS630SE-C								
800	XS630SE								
	XH630SE								
	XS800NJ	3,4	TFJ36X	168	126	117	70	M8	+4.5
	XS800SE								
1250	XH800SE								
	XS1250SE	3,4	TFJ38X	197	184	154	70	Ø9	+15
1600	XS1600SE	3,4	TFJ38X	217	184	154	70	Ø9	+15

5

Optional Accessories

Externally Mounted Accessories

Handle Operating Mechanism, Panel Mounted, Variable Depth Type (OHH)

This consists of an operating mechanism mounted on the breaker, an operating handle mounted on the panel door and a square shaft to connect the mechanism with the handle.

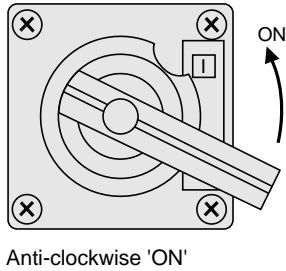

Anti-clockwise 'ON'

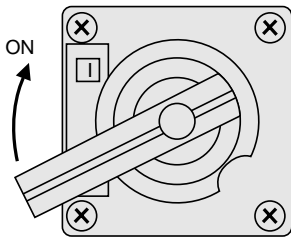

Clockwise 'ON'

Operating direction of handle

There are two types: Anti-clockwise for 'ON' and clockwise for 'ON'. They are distinguished by their type designation.

Panel lock

The external operating handle keeps the panel door locked when in the 'ON' position. There are two types, RESET, Open and OFF, Open.

Reset, Open (Standard type)

The handle is turned to the 'RESET/OPEN COVER' position to open the panel door.

OFF, Open

The handle is turned to the OFF position to open the panel door.

Panel lock release knob

The release knob enables the panel door to be opened with the handle in the 'ON' position. To release: turn the release knob in the direction of the arrow (marked) with a flat-bladed screwdriver.

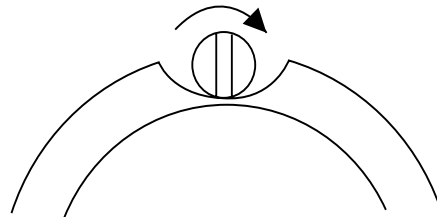

Panel lock release knob

Handle lock (Variations of use)

The operating handle can be padlocked in the 'ON' or 'OFF' position. The operating mechanism mounted on the breaker can be padlocked (not supplied) in the 'ON' or 'OFF' position.

Handle switch (optional)

A microswitch (contact 1C) may be fitted onto the operating mechanism for ON-OFF status indication and electrical interlocking purposes.

Mounting direction of breaker

The breaker mounting directions are allowed with this type of handle (OHH), as follows:

- (1) Vertical with the 'ON' position up. (normal) (refer to figure 4).
- (2) Horizontal with the 'ON' position left hand side (Refer to Figure 5).
- (3) Horizontal with the 'ON' position right hand side (Refer to Figure 6).

Note: Relative positioning of the breaker and the handle (OHH) differs from one mounting direction to another (Refer to Figures 4,5 and 6).

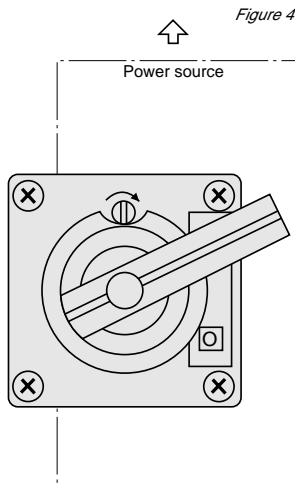

Vertical mounting ('ON' position up)

Figure 5

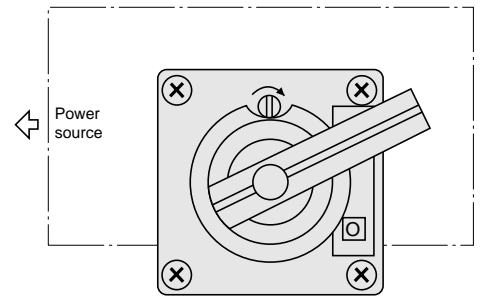

Horizontal mounting ('ON' position left hand side)

Figure 6

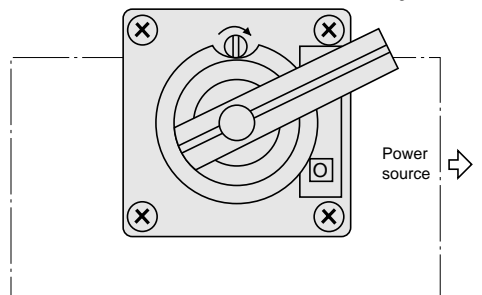

Horizontal mounting ('ON' position right hand side)

Square shaft standard dimensions (refer to Table 2). Shafts can be cut to required length. Refer to page 66 for cutting procedure, and Tables 3 and 4 for dimensions.

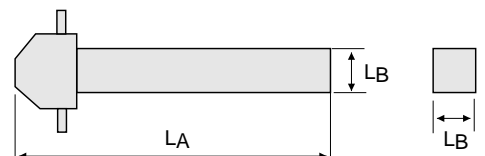

Table 2

Shaft type	LA (mm)	LB (mm)	Frame (A)
STD1	327	8	50-250
LNG1	427		
STD2	304.5	15.8	400-1600
LNG2	404.5		

5

Optional Accessories

Externally Mounted Accessories

Handle Operating Mechanism, Panel Mounted, Variable Depth Type (OHH)

Shaft selection and cutting procedures

Measure the length (F) between the front cover surface and mounting face of the breaker (Refer to Figure 7). Compare this length to the dimension table (Refer to Tables 3 and 4. Applicable Shaft 'F').

If the shaft measured is not of a standard length 'F', then cut the shaft to the required length (Refer to Figure 8).

Apply rust inhibitor to the exposed end (aluminium bronze paint or similar).

Note: Please specify the correct catalogue code when ordering, as follows:

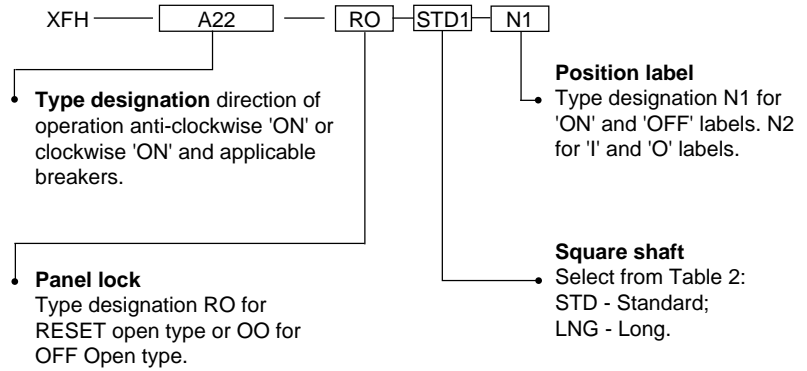

NOTE: Colour of handle, Black.

Figure 7

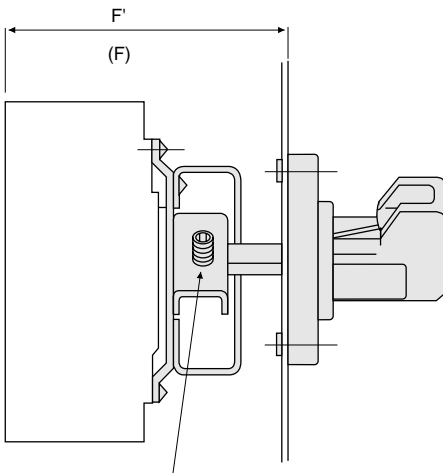

Square shaft fixing screw
 For types 1 and 2 size M5
 For types 3 and 4 size M6

Figure 8

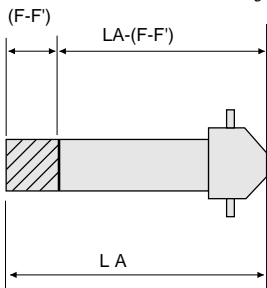

5

Optional Accessories

Externally Mounted Accessories

Handle Operating Mechanism, Panel Mounted, Variable Depth Type (OHH)

Outline dimensions (mm)

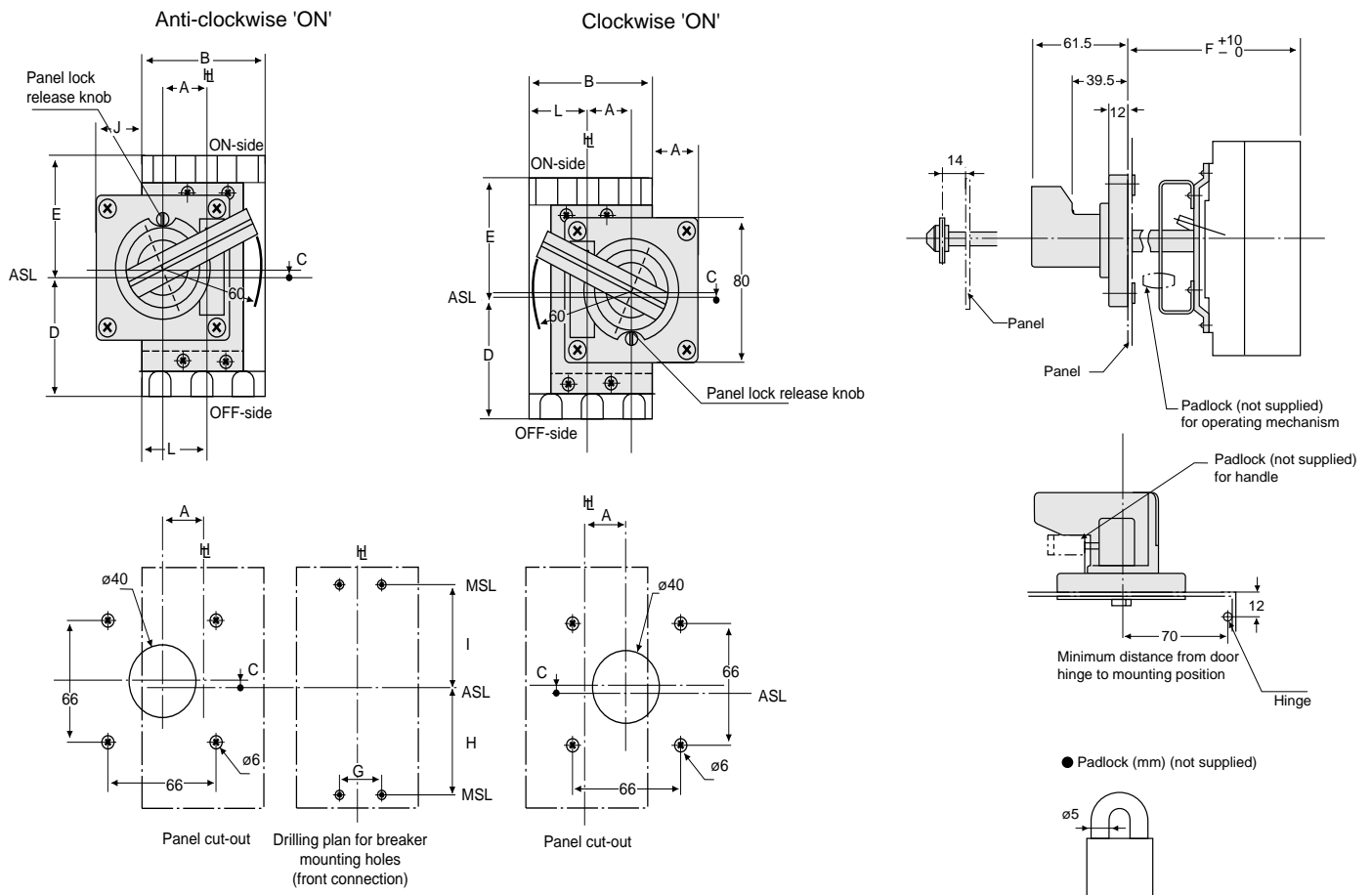

Dimensions table (mm)

Table 3

Frame (A)	Breaker	No. of poles	Anti-clockwise ON	Clockwise ON	A	B	C	D	E	F	G	H	I	J	L		
											Applicable shaft						
											STD1	LNG1					
30	XM30PB	3	XFHA1B	XFHC1B	25	78	4	72.8	81.3	373	473	25	57.5	57.5	26	39	
50	XS50NB	3	XFHA1	XFHC1	25	75	4	65	65	373	473	25	55.5	55.5	27.75	37.5	
100/125	XE100NS	3	XFHA1	XFHC1	25	75	4	65	65	373	473	25	55.5	55.5	27.75	37.5	
	XS125CJ	3	XFHA22	XFHC22	30	90	4	77.5	77.5	373	473	30	66	66	25	45	
	XS125NJ	4						120									
160/225250	XE225NS	3	XFHA23S	XFHC23S	30	105	0	82.5	82.5	390	490	35	63	63	17.5	52.5	
	XS160NJ	4						140									
	XS250NJ	4						140									
	XS250PJ	3	XFHA23H	XFHC23H	30	105	0	82.5	82.5	407	507	35	63	63	17.5	52.5	
	XH160NJ	4						140									
	XH250NJ	4						140									

5

Optional Accessories Externally Mounted Accessories

Handle Operating Mechanism, Panel Mounted, Variable Depth Type (OHH)

Outline dimensions (mm)

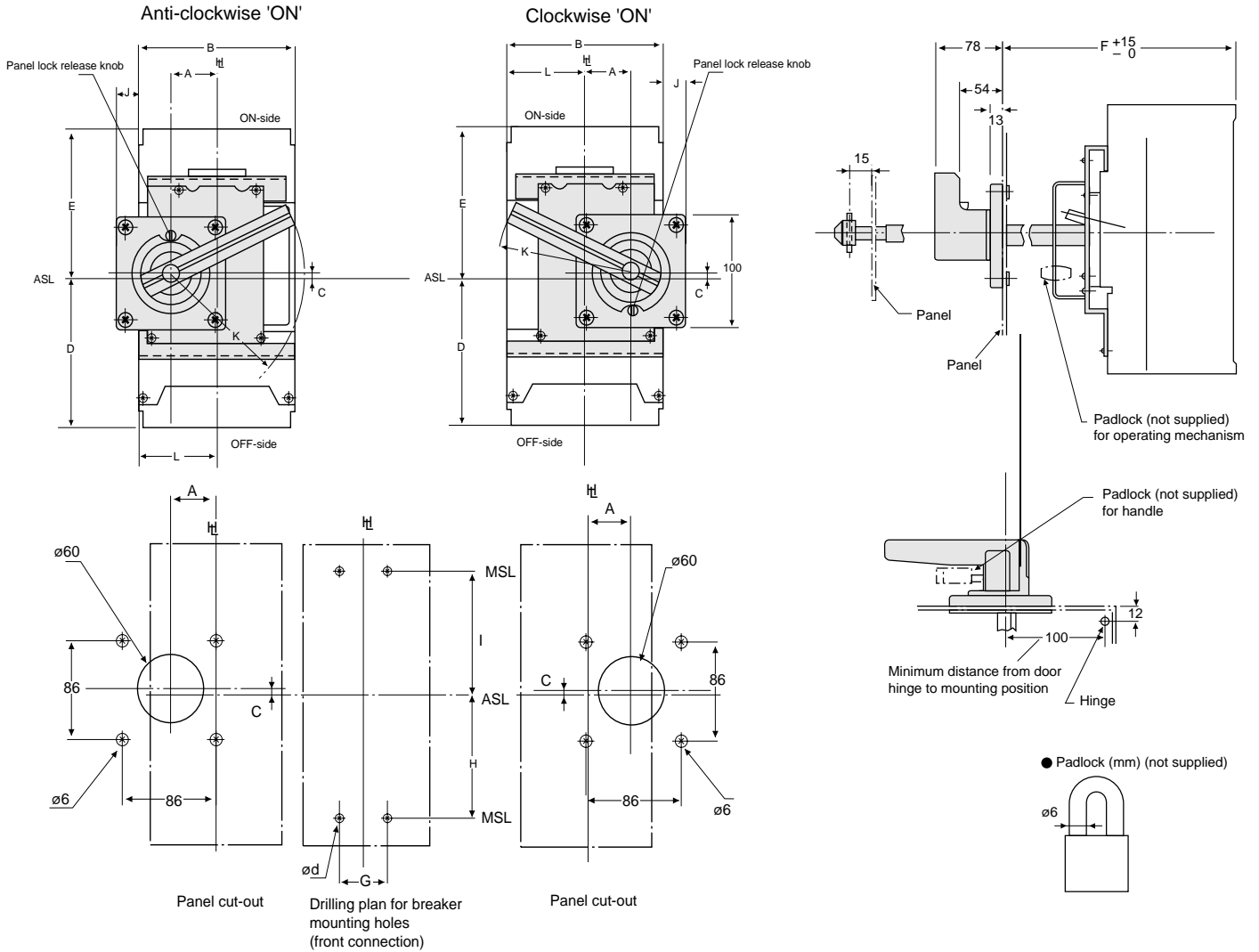

Dimensions table (mm)

Table 4

Frame (A)	Breaker	No. of poles	Anti-clockwise ON	Clockwise ON	A	B	C	D	E	F		G	H	I	J	K	L	d
										Applicable shaft STD2	LNG2							
250	XH250PE	3	XFHA34	XFHC34	42	140	4	130	130	382.5	482.5	45	107	107	22	100	70	M6
		4																
400	XE400NS XS400CJ XS400NJ XS400SE-C XS400SE XH400SE	3	XFHA34	XFHC34	42	140	4	130	130	382.5	482.5	45	107	107	22	100	70	M6
		3																
		3																
		4																
		4																
600	XE600NS XS630CJ XS630NJ XS630SE-C XS630SE XH630SE	3	XFHA46	XFHC46	55	210	4.5	132	141	384	484	70	117	126	0	140	105	M8
		3																
		3																
		4																
		4																
800	XS800NJ XS800SE XH800PS XH800SE	3	XFHA46	XFHC46	55	210	4.5	132	141	384	484	70	117	126	0	140	105	M8
		4																
		4																
		4																
1250	XS1250SE	3	XFHA49	XFHC49	55	210	8.5	170	200	415	515	70	154	184	0	140	105	M8
		4																
1600	XS1600SE	3	XFHA49	XFHC49	55	210	8.5	170	200	435	535	70	154	184	0	140	105	M8
		4																

5

Optional Accessories

Externally Mounted Accessories

Handle Extension (EHA)

Outline dimensions (mm)

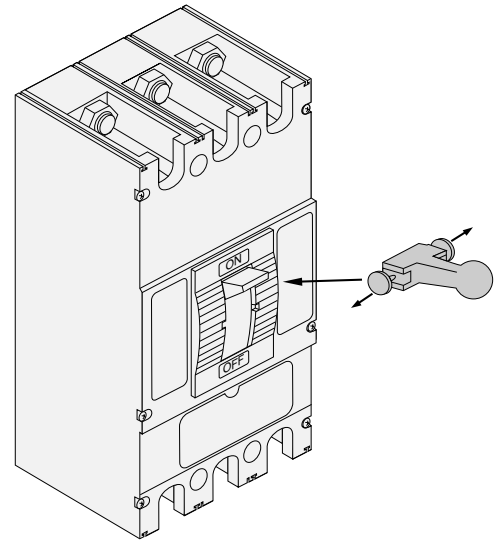
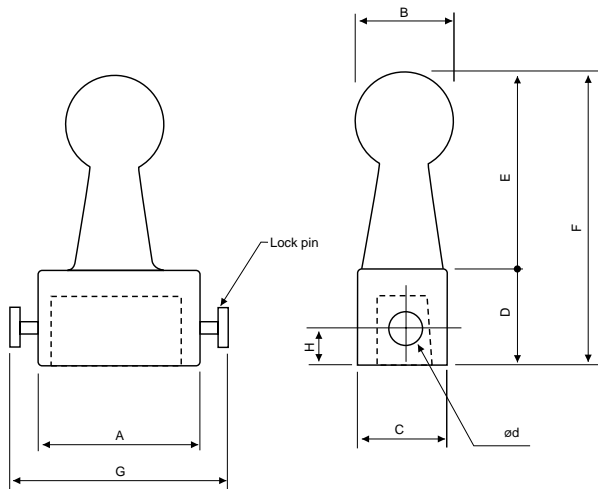

Handle Mounting and Removal

Pull lock pins out left and right in the direction of the arrows, and slot the extension handle in to place.

CAUTION! The lock pins are spring loaded.

Removal - Pull out left and right hand lock pins and hold while removing.

Dimensions table (mm)

Frame (A)	Breaker	Type	A	B	C	D	E	F	G	H	ø d
600/630	XE600NS	XHA9	60	40	26	37	71	108	78	10.5	10
	XS630CJ										
	XS630SE-C										
	XS630SE										
	XH630SE										
800	XS800NJ										
	XS800SE, XH800PS										
	XH800SE										
1250	XS1250SE										
1600	XS1600SE										
*2000	XS2000NE	XHA10	79	46	40	48	88	136	115	17	16
*2500	XS2500NE										

Note: * Handle is supplied as standard with each breaker. (Optional with all other breakers)

5

Optional Accessories

Externally Mounted Accessories

Handle Holder (HH), Handle Lock (HL) and Key Lock

Handle holder (HH)

Position the handle holder (Refer to Figure 9) onto the breaker handle. This retains the handle in the position required (ON or OFF) and also informs other would-be operators to leave the breaker in the position indicated.

Handle holder and handle lock types

Frame (A)	Breaker	Handle holder	Figure No.	Handle lock	Figure No.
30	XM30PB	TKB-1DH	9	*	10
50	XS50NB	TKB-1DH	9	*	10
100/125	XE100NS	TKB-1DH	9	*	10
	XS125CS, XS125NS	-	-	XKC2	11 (1 = 36)
	XS125CJ, XS125NJ, XH125NJ	XKC2	11 (1 = 36)	XKC2	11 (1 = 36)
160/225/250	XE225NS, XS160NJ, XS250NJ	XKC3	11 (1 = 39)	XKC3	11 (1 = 36)
	XS250PJ, XH160NJ, XH250NJ				
	XH250PE	XKC4B	11 (1 = 58)	XKC4	11 (1 = 58)
400	XE400NS, XS400CJ, XS400NJ	XKC4B	11 (1 = 58)	XKC4	11 (1 = 58)
	XS400SE-C, XS400SE, XH400SE				
600/630	XE600NS, XS630CJ, XS630NJ	XKC-6	11 (1 = 76)	XKC6	11 (1 = 76)
	XS630SE-C, XS630SE, XH630SE				
800	XS800NJ, XS800SE, XH800PS	XKC6	11 (1 = 76)	XKC6	11 (1 = 76)
	XH800SE				
1250	XS1250SE	XKC9	11 (1 = 86)	XKC9	11 (1 = 86)
1600	XS1600SE	XKC9	11 (1 = 86)	XKC9	11 (1 = 86)
2000	XS2000NE	XKC10	11 (1 = 94)	XKC10	11 (1 = 94)
2500	XS2500NE	XKC10	11 (1 = 94)	XKC10	11 (1 = 94)

Note: * Specify handle lock (HL) at the time of ordering the breaker

Handle lock (HL)

The Handle lock (Refer to Figures 10 and 11) enables the breaker to be padlocked (not supplied) in either the 'ON' or 'OFF' position.

Key lock

MCCBs of 125AF to 2500AF can be supplied fitted with Castell Locks, including those with OHH handles (pages 65-68) and certain motor operators. Please contact Terasaki for details.

Figure 9

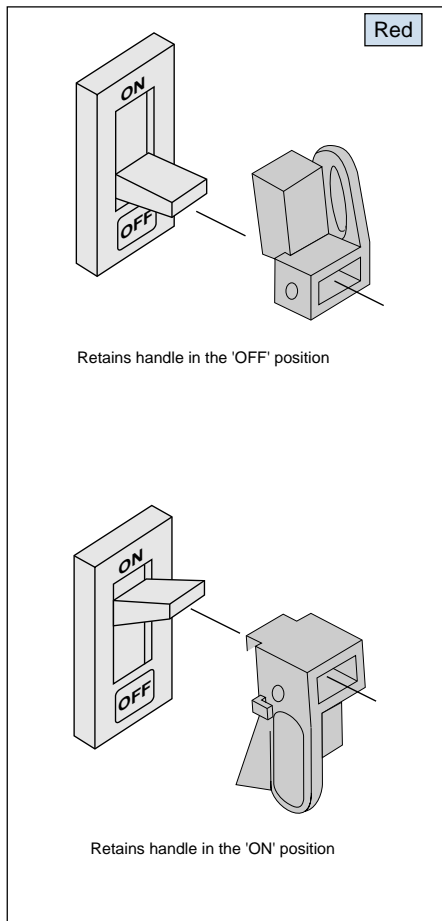

Figure 10

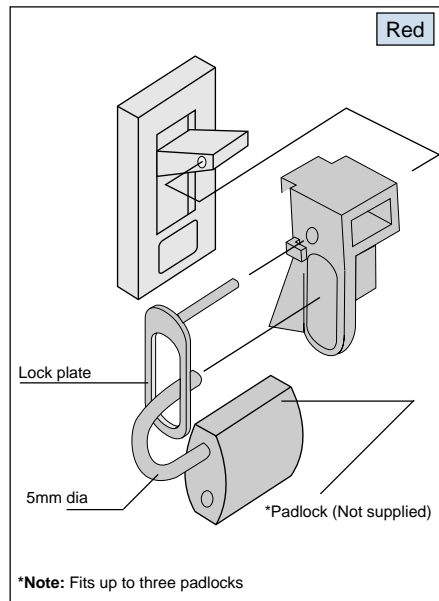
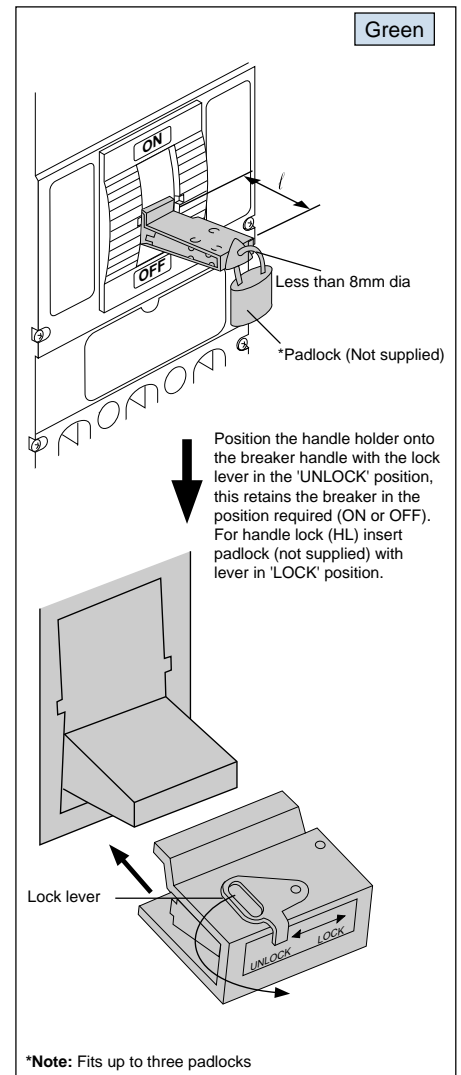

Figure 11



5

Optional Accessories

Externally Mounted Accessories

Interlocking Solutions

Front Mechanical Interlock (MIF)

Outline dimensions (mm)

ASL: Arrangement Standard Line

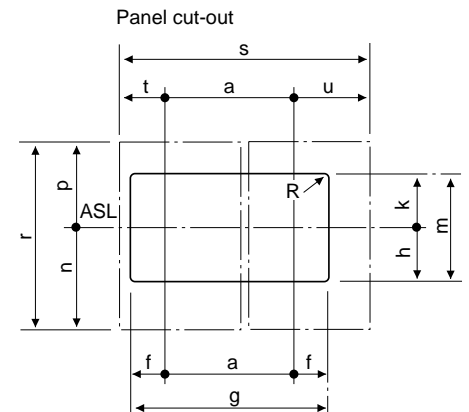
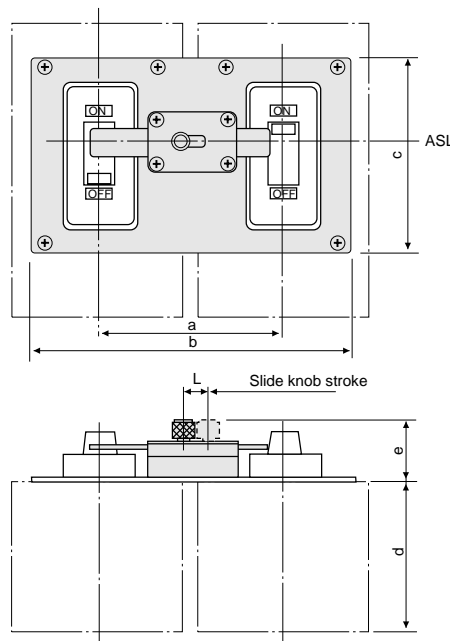

Note: Not applicable to front connection/
attached flat bar type breakers of 160,225,250
and 400A frame sizes

Dimensions table (mm)

Frame (A)	Breaker	Pole	a	b	c	d	e	f	g	h	k	m	n	p	r	s	t	u	L	R
30	XM30PB	3	100	150	102	100	31.6	26.5	153	52.5	52.5	105	65	65	130	175	37.5	37.5	15	8.5
50	XS50NB	3	100	150	102	68	31.6	26.5	153	52.5	52.5	105	65	65	130	175	37.5	37.5	15	8.5
100/125	XE100NS	3	100	150	102	68	31.6	26.5	153	52.5	52.5	105	65	65	130	175	37.5	37.5	15	8.5
	XS125CJ	3	100	150	122	86	31.6	26.5	153	62.5	62.5	125	77.5	77.5	155	190	45	45	15	8.5
	XS125NJ																			
160/225/250	XH125NJ	4	130	180	122	86	31.6	26.5	183	62.5	62.5	125	77.5	77.5	155	250	45	75	15	8.5
	XE225NS	3	115	180	108.5	86	31.6	34	183	51.5	60	111.5	82.5	82.5	165	220	52.5	52.5	15	8.5
	XS160NJ	4	150	215	108.5	86	31.6	34	218	51.5	60	111.5	82.5	82.5	165	290	52.5	87.5	15	8.5
	XS250NJ																			
	XS250PJ					103														
	XH160NJ					103														
400	XH250NJ					103														
	XH250PE	3	150	280	124	103	31.6	66.5	283	57.5	69.5	127	130	130	260	290	70	70	15	8.5
	XE400NS	4	195	325	124	103	31.6	66.5	328	57.5	69.5	127	130	130	260	380	70	115	15	8.5
	XS400CJ	3	150	280	124	103	31.6	66.5	283	57.5	69.5	127	130	130	260	290	70	70	15	8.5
	XS400NJ	4	195	325	124	103	31.6	66.5	328	57.5	69.5	127	130	130	260	380	70	115	15	8.5
600/630	XS400SE-C																			
	XS400SE																			
	XH400SE																			
	XE600NS	3	220	350	136	103	31.6	66.5	353	57.5	81.5	139	132	141	273	430	105	105	30	8.5
	XS630CJ	4	290	420	136	103	31.6	66.5	423	57.5	81.5	139	132	141	273	570	105	175	30	8.5
	XS630NJ																			
800	XS630SE-C																			
	XS630SE																			
	XH630SE																			
	XS800NJ	3	220	350	136	103	31.6	66.5	353	57.5	81.5	139	132	141	273	430	105	105	30	8.5
1250	XS800SE	4	290	420	136	103	31.6	66.5	423	57.5	81.5	139	132	141	273	570	105	175	30	
	XH800PS																			
	XH800SE																			
1600	XS1250SE	3	220	340	129	120	39.6	61.5	343	58	74	132	170	200	370	430	105	105	30	8.5
		4	290	410	129	120	39.6	61.5	413	58	74	132	170	200	370	570	105	175	30	8.5
2000	XS1600SE	3	220	340	129	140	39.6	61.5	343	58	74	132	170	200	370	430	105	105	30	8.5
		4	290	410	129	140	39.6	61.5	413	58	74	132	170	200	370	570	105	175	30	8.5
2500	XS2000NE	3	330	-	-	185	40	59.5	449	72	72	144	193	257	450	650	160	160	25	10
		4	440	-	-	185	40	59.5	559	72	72	144	193	257	450	869	160	269	25	10
2500	XS2500NE	3	330	-	-	185	40	59.5	449	72	72	144	193	257	450	650	160	160	25	10
		4	440	-	-	185	40	59.5	559	72	72	144	193	257	450	869	160	269	25	10

Key Interlock

Remotely located MCCBs, or those at different frame sizes, can be interlocked using the Castell key exchange system. MCCBs of 125AF to 2500AF can be supplied fitted with Castell locks, including those with OHH handles (pages 65-68) and certain motor operators. Please contact Terasaki for details.

5

Optional Accessories Externally Mounted Accessories Interlocking Solutions

Rear Mechanical Interlock (MIB) Outline dimensions (mm)

ASL: Arrangement Standard Line
HL: Handle Frame Centre Line

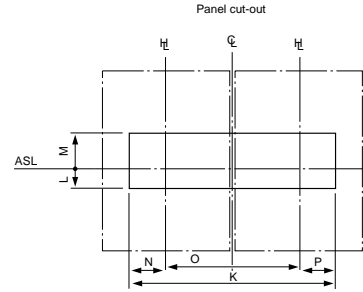
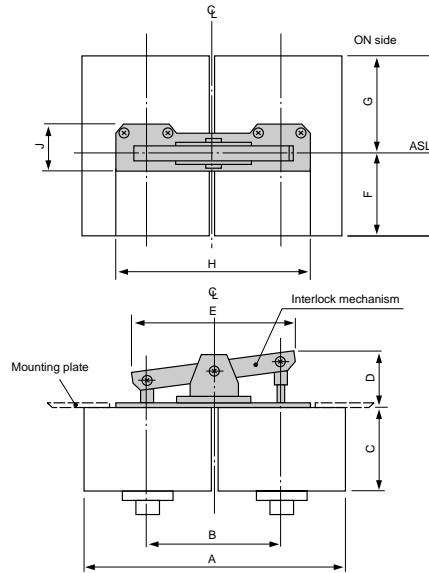

Note: Not applicable for front connected type with terminal bars of 160, 225, 250, and 400A frame sizes. Contact Terasaki for details.

Dimensions table (mm)

Frame (A)	Breaker	Pole	A	B	C	D	E	F	G	H	J	K	L	M	N	O	P
50	XS50NB	3	155	80	68	34	92	65	65	155	55	165	40	25	42.5	80	42.5
100/125	XE100NS	3	155	80	68	34	92	65	65	155	55	165	40	25	42.5	80	42.5
	XS125CJ	3	185	95	86	35	107	77.5	77.5	160	43	170	33	20	28	95	47
	XS125NJ	4	245	125	86	35	137	77.5	77.5	190	43	200	33	20	28	125	47
160/225/250	XE225NS	3	220	115	86	45	130	82.5	82.5	190	44	200	19.5	34.5	30	115	40
	XS160NJ	4	290	150	86	45	165	82.5	82.5	225	44	220	19.5	34.5	30	150	40
	XS250NJ																
	XS250PJ					103											
	XH160NJ					103											
	XH250NJ					103											
	XH250PE	3	285	145	103	58	161	130	130	220	72	250	21	41	52.5	145	52.5
	4	375	190	103	58	206	130	130	265	72	295	21	41	52.5	190	52.5	
400	XE400NS	3	285	145	103	58	161	130	130	220	72	250	21	41	52.5	145	52.5
	XS400CJ	4	425	190	103	58	206	130	130	265	72	295	21	41	52.5	190	52.5
	XS400NJ																
	XS400SE-C																
	XS400SE																
	XH400SE																
600/630	XE600NS	3	430	220	103	74	250	132	141	430	83	440	41	52	110	220	110
	XS630CJ	4	570	290	103	74	320	132	141	500	83	510	41	52	110	290	110
	XS630NJ																
	XS630SE-C																
	XS630SE																
	XH630SE																
800	XS800NJ	3	430	220	103	74	250	132	141	430	83	440	41	52	110	220	110
	XS800SE	4	570	290	103	74	320	132	141	500	83	510	41	52	110	290	110
	XH800PS																
	XH800SE																
1250	XS1250SE	3	*														
		4	*														
1600	XS1600SE	3	*														
		4	*														
2000	XS2000NE	3	*														
		4	*														
2500	XS2500NE	3	*														
		4	*														

Note: * Contact Terasaki for details.

5

Optional Accessories

Externally Mounted Accessories

Interlocking Solutions

Wire Mechanical Interlock (MIW)

Wire mechanical interlocking is a practical solution for breakers mounted in separate cubicle compartments, or of different frame sizes. The system can be applied to breakers positioned at any angle relative to each other, provided the installation limits are observed.

Combination table for wire mechanical interlock

	XLW 4	XLW 6	XLW 8	XLW 9	XLW 10
XLW 4	•	•	–	–	–
XLW 6	•	•	•	•	–
XLW 8	–	•	•	•	–
XLW 9	–	•	•	•	•
XLW 10	–	–	–	•	•

Note: • 'Yes' or available.
– 'No' or not available.

XLW 4	XLW 6	XLW 8	XLW 9	XLW 10
XE400NS	XE600NS	XS1250NN	XS1600NN	XS2000NN
XS400NN	XS630CJ	XS1250SE	XS1600SE	XS2000NE
XS400CJ	XS630NJ			XS2500NN
XS400NJ	XS630NN			XS2500NE
XS400SE	XS630SE-C			
XH250PE	XS630SE			
XH400SE	XH630SE			
	XS800NJ			
	XS800NN			
	XS800SE			
	XH800PS			
	XH800SE			

Installation of wire mechanical interlock

Wire Length (m)	Mounting Pitch, P (mm)	Hole Position Length, L (mm)	Wire Support Method
1.5	1000	550	Support 2 points at equal intervals
	900	600	
	750	700	
1.0	650	450	Support at the centre
	500	500	
	350	530	
	*(1)	^	
	*(2)	^	

*(1): minimum of 60mm + cubicle partition thickness
*(2): minimum of arc base distance if vertical.
^ : intermediate dimensions are acceptable.

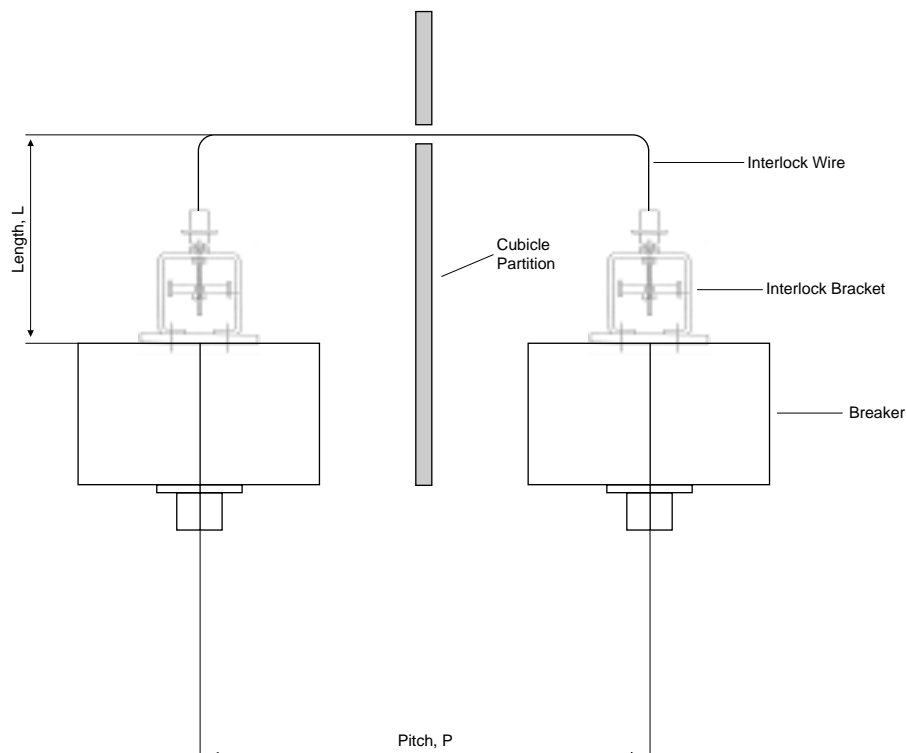

5

Optional Accessories Externally Mounted Accessories Changeover Pair Types

Manual changeover pair, rear mechanically interlocked, with or without motor operators.

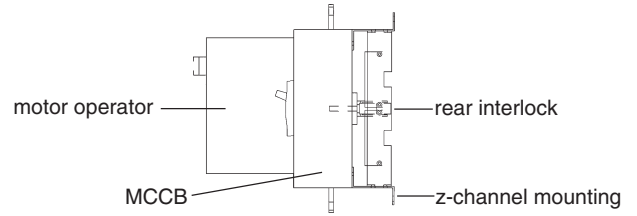
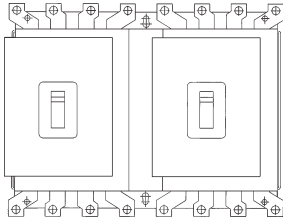

Changeover pair with electrical accessories and terminal block. Mechanical and electrical interlock possible.

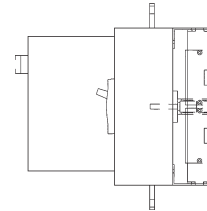
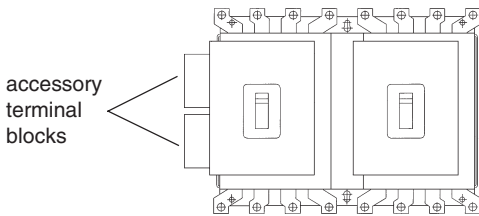

Automatic changeover pair, with TemTransfer controller.

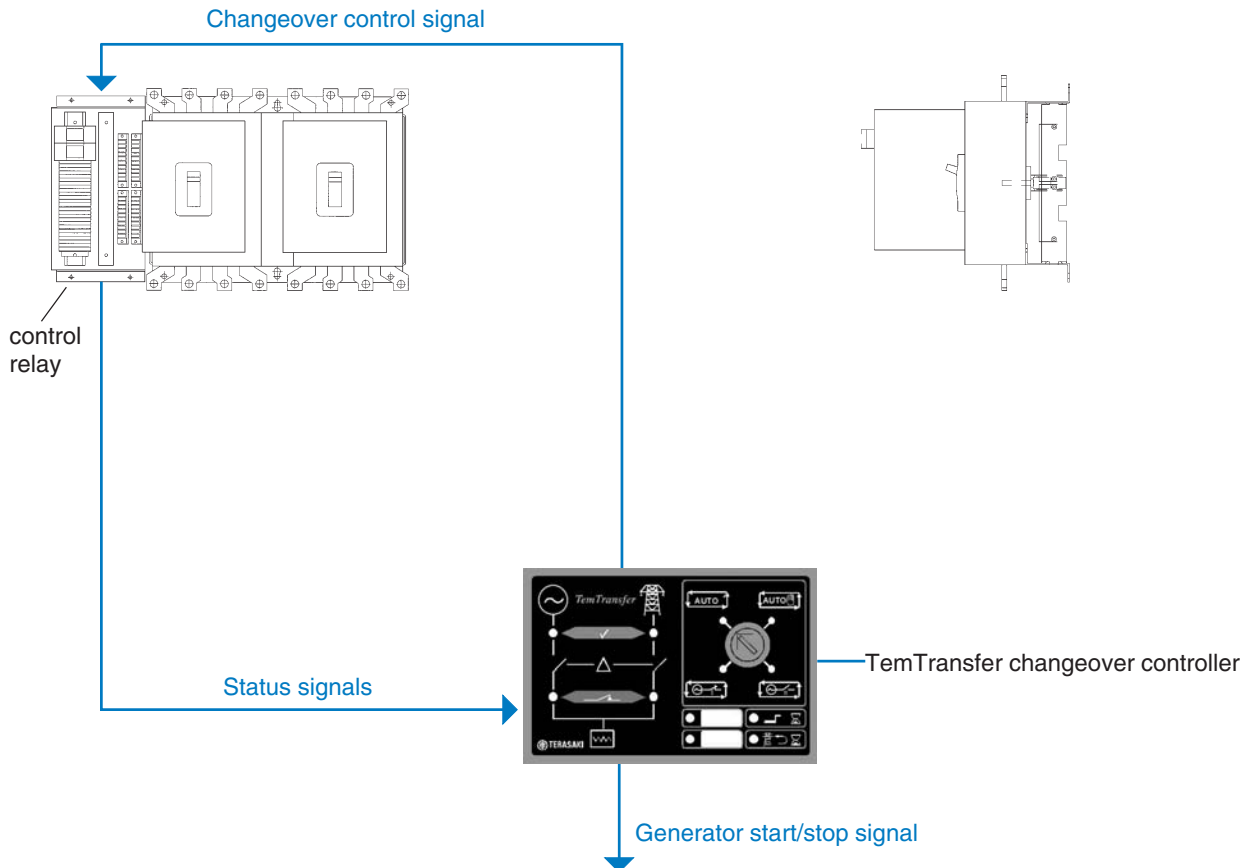

5

Optional Accessories

Externally Mounted Accessories

Terminal Cover

Front-connection application (TCF)

Note: The terminal cover protects breaker terminals and other live parts from exposure. Terminal covers available for front or rear connection and plug-in types. Adapts to breaker type and use application.

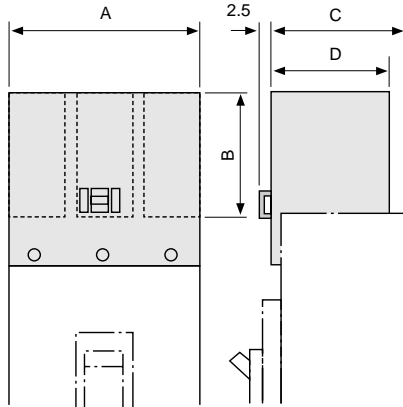

Screw-on Cover (Refer to Figure 13)

Screw directly onto insert nuts in breaker cover.

Note: Insert nuts are not provided as standard on breaker cover. Please specify if terminal cover (TCF) is to be used when ordering the breaker.

Snap-on Cover

XPR Type. To remove: press lever in direction of 'TAKE OFF' position (Refer to Figure 12).

Figure 12

Lever detail

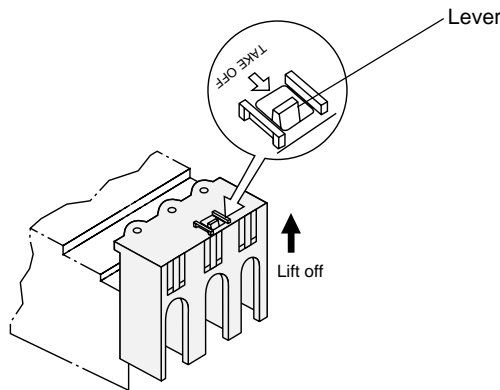

(Option for IP20 protection)

Figure 13

Mounting screw

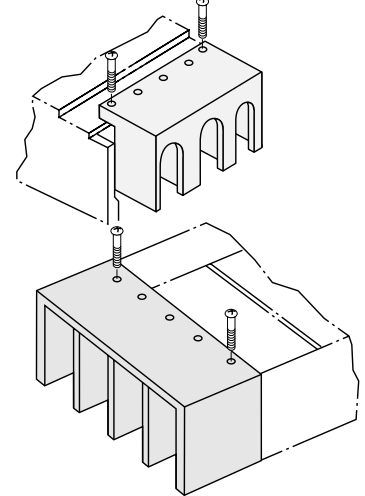

IP20 Terminal covers are available

Fitting instructions (Option for IP20 protection). Figure 12

- 1: Cut holes in the pole covers to suit the size of the cable. (An elongated hole is recommended)
- 2: Before cable crimps are fitted, attach the pole covers to the cables.
- 3: Attach the cables to the MCCB terminals.
- 4: Attach the terminal cover to the MCCB. Ensure that the pole covers slide into the pole cover slots as the terminal cover is fitted.

Dimensions table (mm)

Frame (A)	Breaker	Type	Pole	A	B	C	D	Snap-on	Screw-on	Figure No.
50	XS50NB	XPR0	2	49	25	63	54	•	–	24
			3	74						
100/125	XE100NS	XPR1	3	49	25	63	54	•	–	24
			4	74						
160/225/250	XS125CS, XS125NS	XPR2H	1	30	40	79	78	•	–	–
			3	89	40	79	78	•	–	24
	XS125CJ	XPR2H	3	89	40	79	78	•	–	24
			4	124	70	79.4	–	M2.6	24	
	XS125NJ, XH125NJ	XPR3S	3	104	40	81	80	•	–	24
			4	144	70	81.4	–	M2.6	24	
	XE225NS, XS160NJ	XPR3H	3	104	40	98	97	•	–	24
			4	144	70	98.4	–	M2.6	24	
XS250NJ	XPR3H	3	104	40	98	97	•	–	24	
		4	144	70	98.4	–	M2.6	24		
XH250NJ	TPR-4BA	3	140 *180	80	99	96	–	M3	25	
		4	185 *240							
400	XE400NS, XS400CJ	TPR-4BA	3	140 *180	80	99	96	–	M3	25
			4	185 *240						
	XS400NJ	TPR-4BS	3	140 *180						
			4	185 *240						
600/630	XE600NS, XS630CJ	TPR-5BA	3	215	130	99.5 ('ON' side)	99	–	M3	25
			4	285		102.5 ('OFF' side)				
	XS630NJ, XS630SE-C	TPR-5BA	3	215	99.5 ('ON' side)	99	–	M3	25	
XS630SE, XH630SE	4		285	102.5 ('OFF' side)						
800	XS800NJ, XH800PS	TPR-5BA	3	215	130	99.5 ('ON' side)	99	–	M3	25
			4	285		102.5 ('OFF' side)				
1250	XS1250SE	TPR-5BA	3	215	130	115	99	–	M3	25
			4	285						

Note: • Yes or Available. – No or Not available

Note: * Breakers fitted with attached bars require the larger type terminal covers

5

Optional Accessories

Externally Mounted Accessories

Terminal Cover

Rear-connection and Plug-in Application (TCR)

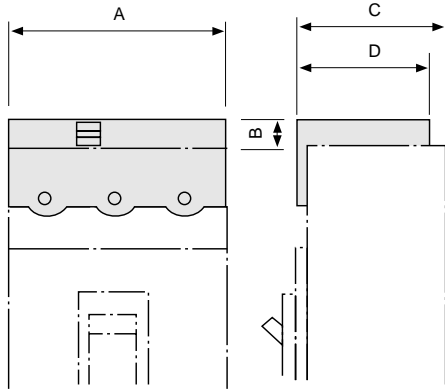

Snap-on cover
(Refer to Figure 14)
To fit; 'snap-on' the cover on to the breaker.
To remove, press lever to 'TAKE OFF' position and lift off.

Screw-on cover (Refer to Figure 15)
Screw directly onto insert nuts in breaker cover.
Note: Insert nuts are not provided as standard on breaker cover. Please specify if terminal cover (TCR) is to be used when ordering breaker.

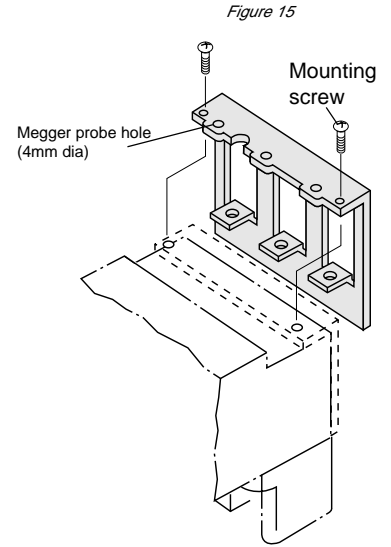
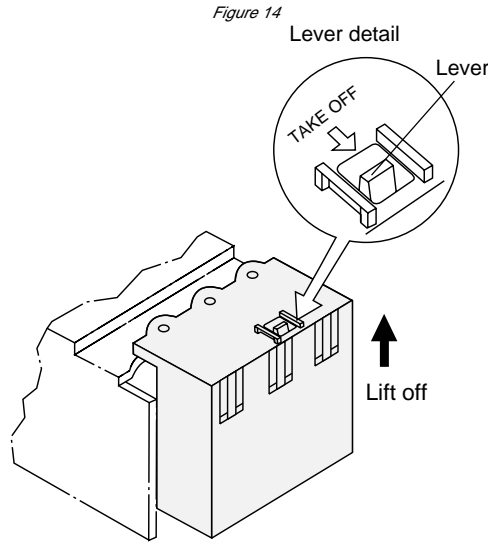

Dimensions table (mm)

Frame (A)	Breaker	Type	Pole	A	B	C	D	Snap-on cover	Screw-on	Figure No.
50	XS50NB	XPS1	2	49	10	55	54	•	–	26
			3	74		63				
100/125	XE100CS	XPS1	2	49	10	55	54	•	–	26
			3	74		63				
	XS125CJ, XS125NJ	XPS2H	3	89	2	61.4	60.4	•	M2.6	27
			4	119						
160/225/250	XE225NS, XS160NJ	XPS3S	3	104	3	81.5	80.5	•	M2.6	27
			4	139						
	XS250PJ, XH160NJ	XPS3H	3	104	3	78.5	97.5	–	M3	
			4	185						
	XH250PE	XPS4	3	140	3	99	98	–	M3	27
4			185							
400	XE400NS, XS400CJ	XPS4	3	140	3	99	98	–	M3	27
			4	185						
			XS400NJ, XS400SE-C							
600/630	XE600NS, XS630CJ	XPS6	3	210	3	99 ('ON' side)	93	–	M3	27
			4	280		105 ('OFF' side)				
	XS630NJ, XS630SE-C	XPS6	3	210	3	99 ('ON' side)	93	–	M3	27
			4	280		105 ('OFF' side)				
800	XS800NJ, XH800PS	XPS6	3	210	3	99 ('ON' side)	93	–	M3	27
			4	280		105 ('OFF' side)				

Note: • 'Yes' or 'Available'. – 'No' or Not available

5

Optional Accessories

Externally Mounted Accessories

Interpole Barrier (TBA)

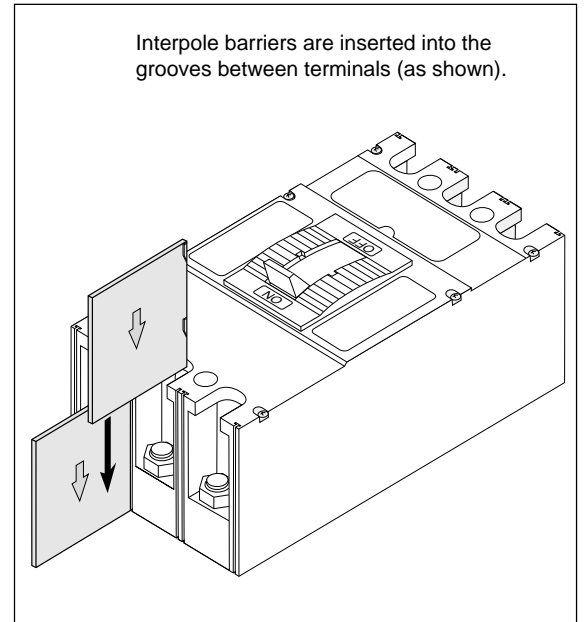
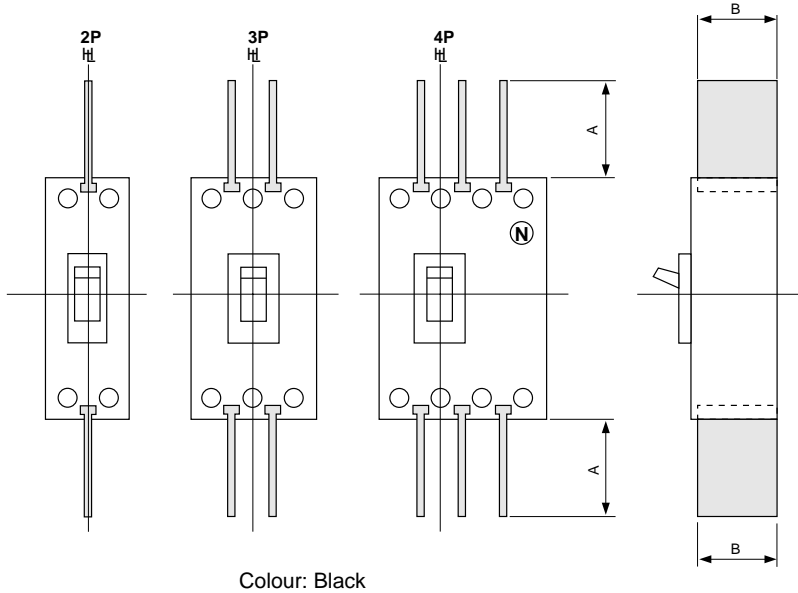

Dimensions table (mm)

Frame (A)	Breaker	Type	A	B
50	XS50NB	TQQ-2CC	36	50
100/125	XE100NS	TQQ-2CC	36	50
	*XS125CJ	XQQ2	67	77
	*XS125NJ			
	*XH125NJ			
160/125/250	*XE225NC	XQQ2	67	77
	*XS160NJ			
	*XS250NJ			
	*XS250PJ	TQQ-3GB	67	96
	*XH160NJ			
	*XH250NJ			
400	*XH250PE	TQQ-5BA	110	95
	*XE400NS	TQQ-5BA	110	95
	*XS400CJ			
	*XS400NJ			
	*XS400SE-C			
	*XS400SE			
	*XH400SE			
600/630	XE600NS	TQQ-5BA	110	95
	XS630CJ			
	XS630NJ			
	XS630SE-C			
	XS630SE			
	XH630SE			
800	XS800NJ	TQQ-5BA	110	95
	XS800SE			
	XH800PS			
	XH800SE			
1250	XS1250SE	TQQ-5BA	110	95
1600	XS1600SE	TQQ-5BA	110	95

Note: * Line side interpole barriers are supplied as standard, as follows: 1 for 2-pole, 2 for 3-pole and 3 for 4-pole breakers.

5

Optional Accessories

Externally Mounted Accessories

Accessory Lead Terminal Blocks 30~250A Frame size (LTS)

Leads for internally mounted accessories are connected to the terminal block. Each terminal block incorporates six terminals. Terminal arrangement assemblies are standard. Please contact Terasaki if terminal arrangement assemblies other than standard are required.

LTS



Mounting position/standard terminal arrangements.

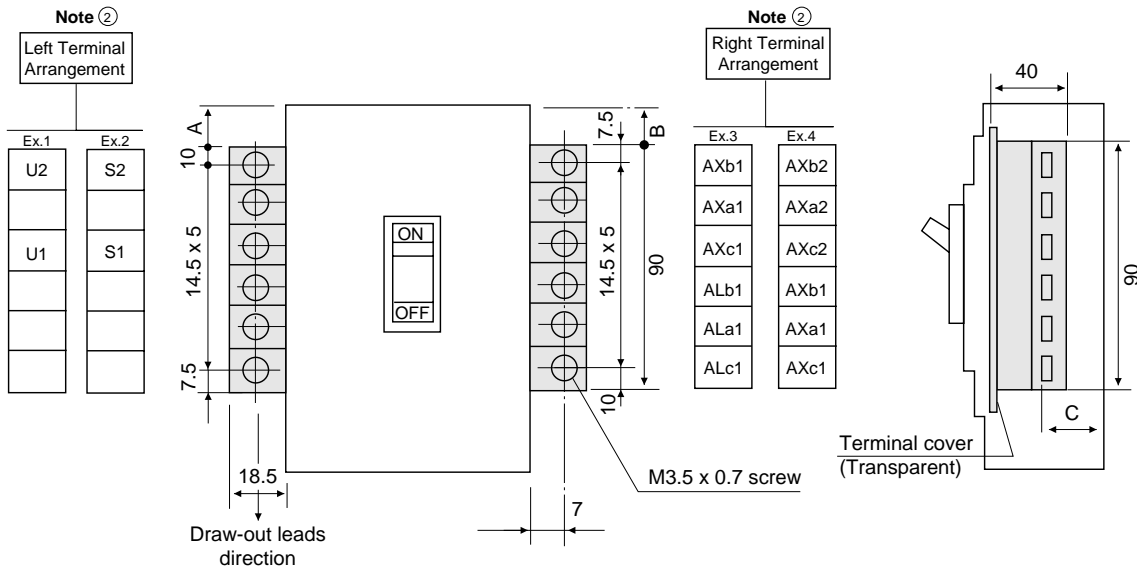

Dimensions table (mm)

Frame (A)	Breaker	A	B	C
30	XM30PB	32.75	32.75	66
50	XS50NB ① ②	16.5	16.5	36
100/125	XS125CS	32.5	32.5	53
	XS125NJ			
	XH125NJ			
160/225/250	XE100NS ①	42	42	60
	XE225NS ①			
	XS160NJ			
	XS250NJ			
	XS250PJ			
	XH160NJ			
XH250NJ				

Note ① Lead terminal block can not be fitted with motor operator.

Note ② For XS50NB 3P and 4P, Lead terminal block is mounted on the right hand side, so that the draw-out leads go in the upper direction.

Remark 1) Standard Torque for the terminal screws
M3.5 - 0.88~1.18 Nm {9~12Kgf.cm}

Remark 2) Connected cable size - Max. 1.25mm²

5

Optional Accessories

Externally Mounted Accessories

Accessory Lead Terminal Blocks 400 ~ 1600A Frame Size (LTF)

Mounting position/standard terminal arrangements.

When used, jointly, with a UVT controller and OCR controller

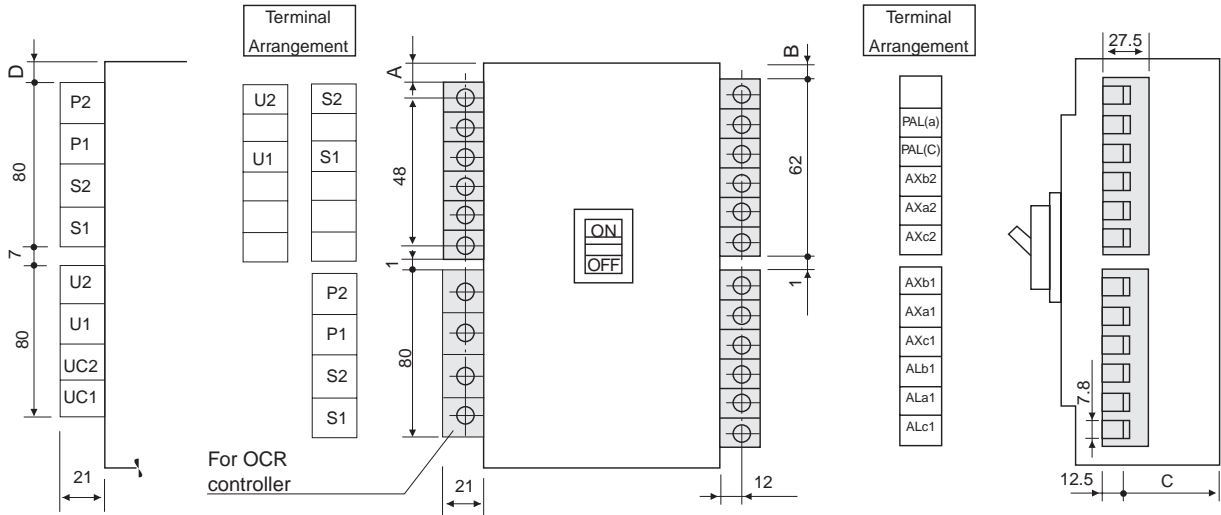

Dimensions table (mm)

Frame (A)	Breaker	A	B	C	D
250	XH250PE	34	34	48	34
400	XE400NS	34	34	48	34
	XS400CJ				
	XS400NJ				
	XS400SE-C				
	XS400SE				
	XH400SE				
600	XE600NS	88	88	60	64
	XS630CJ				
	XS630NJ				
	XS630SE-C				
	XS630SE				
	XH630SE				
800	XS800NJ	88	88	60	64
	XS800SE				
	XH800PS				
	XH800SE				
1250	XS1250SE	51	51	72	51
1600	XS1600SE	51	51	92	51

LTF

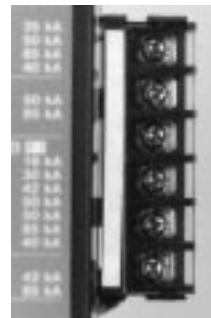

Mounting position/standard terminal arrangements (2000 to 2500A Frame sizes).

When used, jointly, with a UVT controller and OCR controller

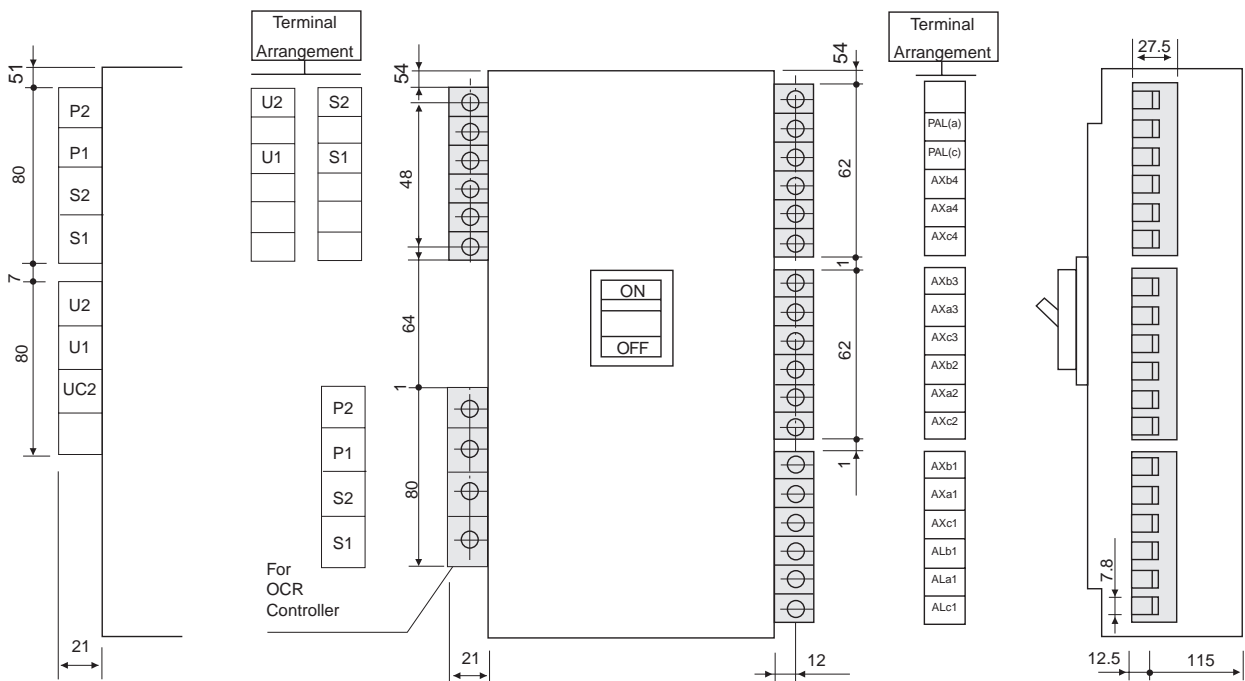

5

Optional Accessories

Externally Mounted Accessories

Door Flange (D.F)

There are five types of panel door cut-out dimensions

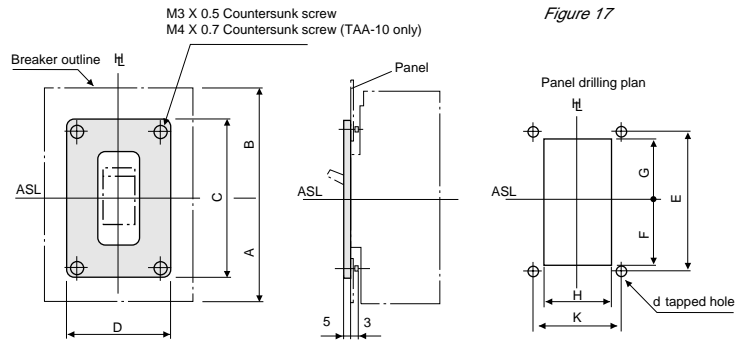
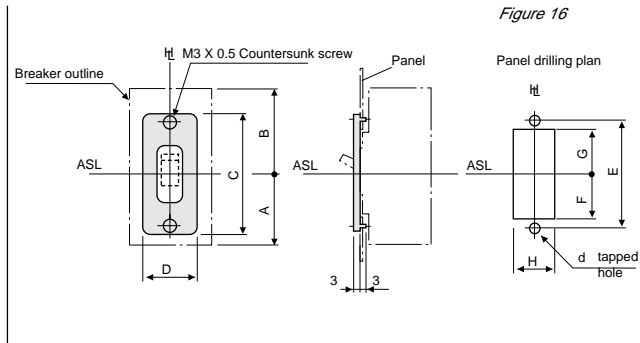

Dimensions table (mm)

Frame (A)	Breaker	Type	A	B	C	D	E	F		G		H		K	d	Figure
								Min	Max	Min	Max	Min	Max			
30	XM30PB	XAA1	66.25	81.25	105	50	92	37	42	37	42	32	45	-	M3x0.5	16
50	XS50NB	XAA-1	65	65	105	50	92	37	42	37	42	32	45	-	M3x0.5	16
100/125	XE100NS	XAA-1	65	65	105	50	92	37	42	37	42	32	45	-	M3x0.5	16
	XS125CJ	XAA-1	77.5	77.5	105	50	92	37	42	37	42	32	45	-	M3x0.5	16
	XS125NJ															
	XH125NJ															
160/225/250	XE225NS	TAA-3CA	85	75	105	50	92	37	42	37	42	32	45	-	M3x0.5	16
	XS160NJ															
	XS250NJ															
	XS250PJ															
	XH160NJ															
400	XH250NJ															
	XH250PE	TAA-4	130	130	135	95	120	48	56	48	56	70	90	80	M3x0.5	17
	XE400NS	TAA-4	130	130	135	95	120	48	56	48	56	70	90	80	M3x0.5	17
	XS400CJ															
	XS400NJ															
600/630	XS400SE-C															
	XS400SE															
	XH400SE															
	XE600NS	TAA-4	132	141	135	95	120	48	56	48	56	70	90	80	M3x0.5	17
	XS630CJ															
800	XS630NJ															
	XS630SE-C															
	XS630SE															
	XH630SE															
	XS800NJ	TAA-4	132	141	135	95	120	48	56	48	56	70	90	80	M3x0.5	17
1250	XS800SE															
	XH800PS															
1600	XH800SE															
	XS1250SE	TAA-5	170	200	150	120	135	51	63.5	51	63.5	85	115	80	M3x0.5	17
2000	XS1600SE	TAA-5	170	200	150	120	135	51	63.5	51	63.5	85	115	80	M3x0.5	17
	XS2000NE	TAA-10	193	257	200	175	175	74	83.5	74	83.5	123	170	150	M4x0.7	17
2500	XS2500NE	TAA-10	193	257	200	175	175	74	83.5	74	83.5	123	170	150	M4x0.7	17

5

Optional Accessories

Externally Mounted Accessories

Panel Cut-out for OCR Adjustment

Outline dimensions (mm)

Adjustable thermal type

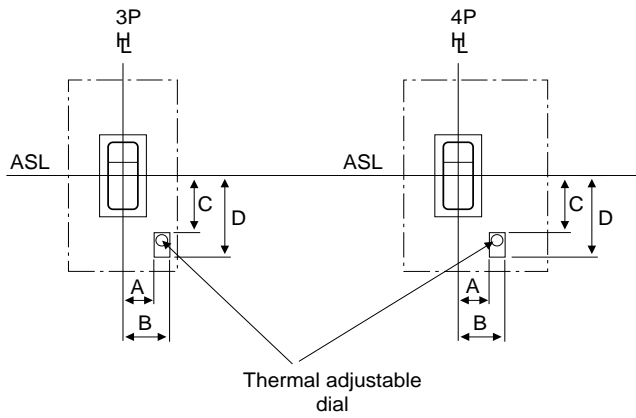

Electronic and Adjustable thermal-magnetic type

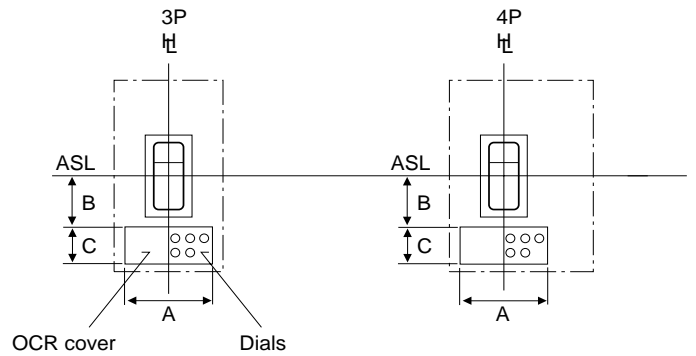

Dimension table (mm)

Frame size (A)	MCCB type	Poles	Dimensions			
			A	B	C	D
125	XS125CJ	3,4	25	43	23.5	50.5
	XS125NJ					
	XH125NJ					
160	XS160NJ	3,4	18	50	20.5	48.5
	XH160NJ					
250	XS250PJ	3,4	18	50	20.5	48.5
	XS250NJ					
	XH250NJ					
	XH250PE					
400	XE400NS	3,4	140	56	40	-
	XS400CJ					
	XS400NJ					
	XS400SE-C					
	XS400SE					
	XH400SE					
600/630	XE600NS	3	210	57	48.5	-
	XS630CJ	3,4	210	57	48.5	-
	XS630NJ					
	XS630SE-C					
	XS630SE					
	XH630SE					
800	XS800NJ	3,4	210	57	48.5	-
	XS800SE					
	XH800PS					
	XH800SE					
1250	XS1250SE	3,4	210	57.5	58	-
1600	XS1600SE	3,4	210	57.5	58	-
2000	XS2000NE	3,4	140	98.5	58	-
2500	XS2500NE	3,4	140	98.5	58	-

5

Optional Accessories

Plug-in Mounting Blocks for Distribution Board

Outline Dimensions (mm)

XE100NS, XS50NB

Double mounting block

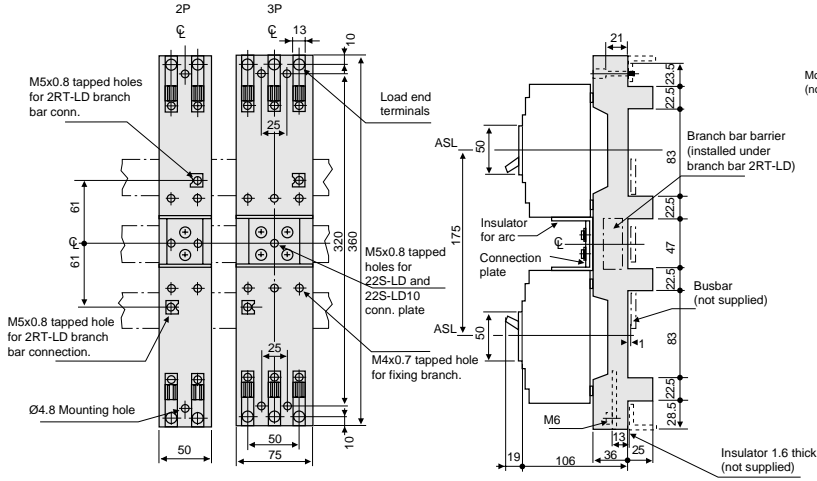

Mounting dimensions

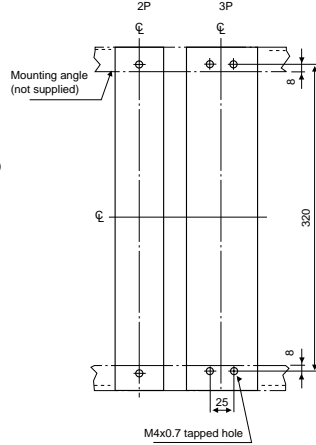

Branching bar

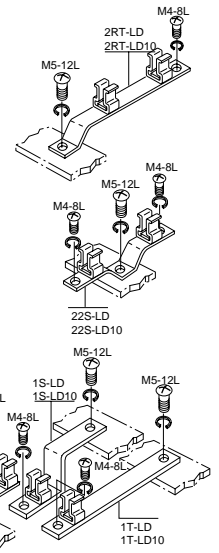

Mounting dimensions

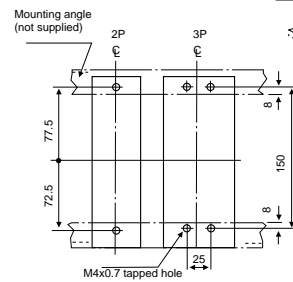

Single mounting block

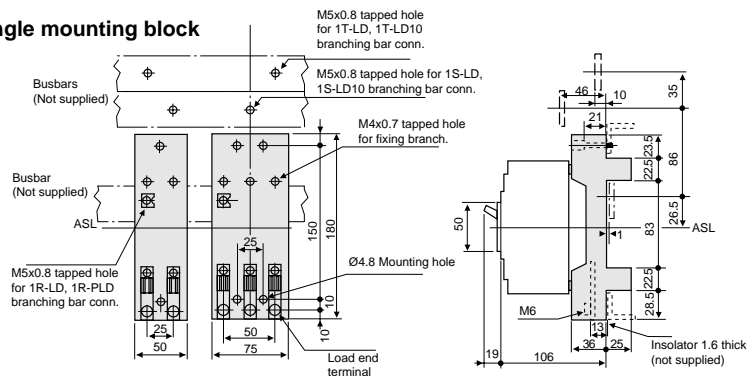

Connecting Plate

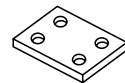

Insulator for Arc

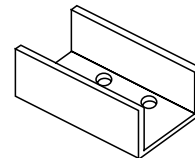

Branching Bar Barrier



Components / Parts to be purchased

	Components / Parts to be purchased		* Quantity	Remarks; 1) Screws supplied. 2) With load side terminals.	
	Type				
Double mounting block	Mounting block	XDA-ID	2	M4-30L-4 pcs (For fixing)	
	Branching bar	2RT-LD	2	M5-12L-12 pcs (Busbar connection) M4-8L-2 pcs (Fixing on mounting block) 10-50A	
		2RT-LD10	2	M5-12L-2 pcs (Busbar connection) M4-8L-2 pcs (Fixing on mounting block) 60-100A	
		22S-LD	1	M5-12L-1 pc (Busbar connection) M4-8L-2 pcs (Fixing on mounting block) 10-50A	
		22S-LD10	2	M5-12L-1 pc (Busbar connection) M4-8L-2 pcs (Fixing on mounting block) 60-100A	
		Connection plate	1	M4-35L-4 pcs	
		Insulator for arc	1		
Single mounting block	Mounting block	XDA-IS	1	M4-30L-4 pcs (For fixing)	
	Branching bar	1R-LD	1	M5-12L-3 pcs (Busbar connection) M4-8L-3 pcs (Fixing on mounting block) 10-50A	
		1R-LD10	1	M5-12L-3 pcs (Busbar connection) M4-8L-3 pcs (Fixing on mounting block) 60-100A	
		1S-LD	1		
		1T-LD	1		
		1S-LD10	1		
		1T-LD10	1		

Note: * The number required to form either single or double mounting blocks

5

Optional Accessories

Plug-in Mounting Blocks for Distribution Board

Outline Dimensions (mm)

XS125NJ, XS125CJ, XH125NJ

Double mounting block

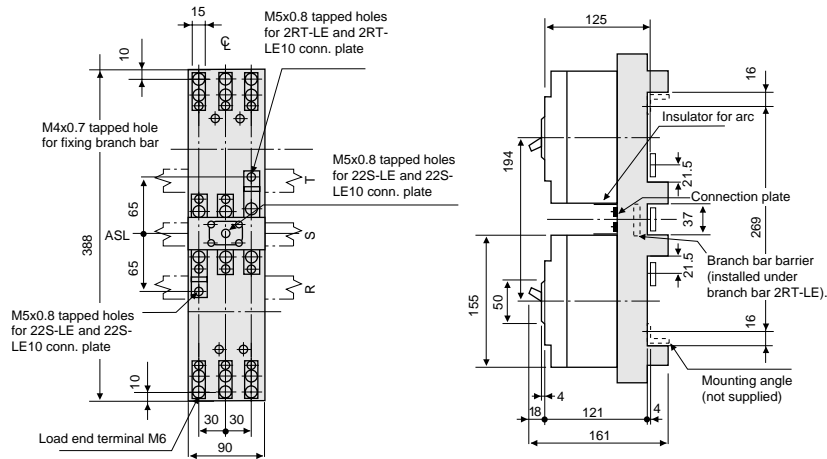

Branching Bar

Mounting dimensions

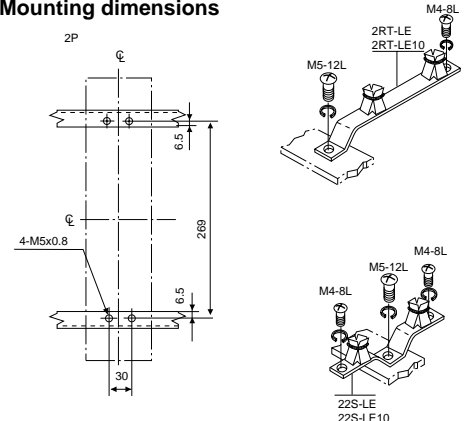

Single mounting block

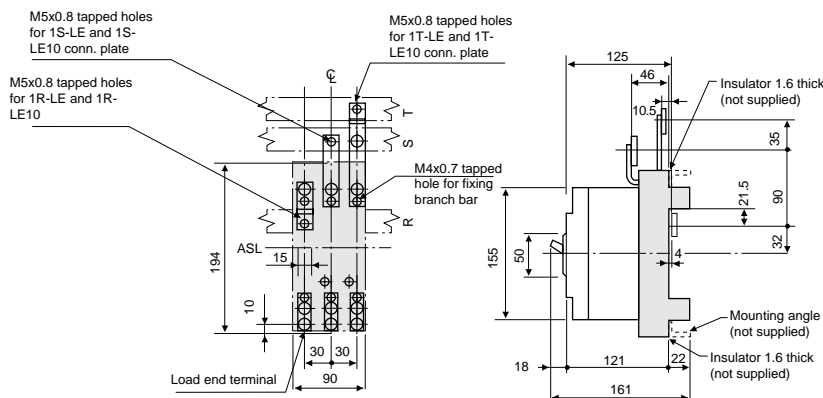

Mounting dimensions

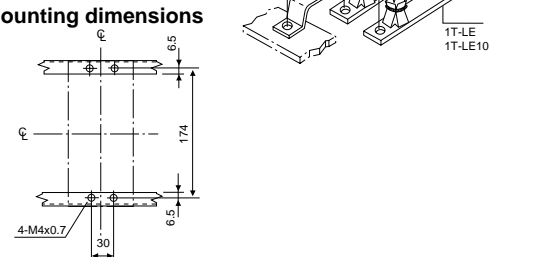

Connecting Plate

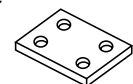

Insulator for Arc

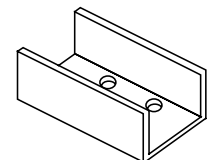

Branching Bar Barrier



Components / Parts to be purchased

Components / Parts to be purchased		* Quantity	Remarks; 1) Screws supplied. 2) With load side terminals.	
Double mounting block	Mounting block	XDA-2D	2	M5-25L-4 pcs (For fixing)
	Branching bar	2RT-LE	2	M5-12L-2 pcs (Busbar connection)
		22S-LE	1	M4-8L-4 pcs (Fixing on mounting block) up to 50A
		22S-LE	1	M5-12L-1 pc (Busbar connection)
		22S-LE	1	M4-8L-2 pcs (Fixing on mounting block) up to 50A
		2RT-LE10	2	M5-12L-2 pcs (Busbar connection)
	Branching bar	2RT-LE10	2	M4-8L-4 pcs (Fixing on mounting block) 60~100A
		22S-LE10	1	M5-12L-1 pc (Busbar connection)
		22S-LE10	1	M4-8L-1 pcs (Fixing on mounting block) 60~100A
		Connection plate		1
Insulator for arc			1	
Single mounting block	Mounting block	XDA-2S	1	M5-25L-2 pcs (For fixing)
	Branching bar	1R-LE	1	M5-12L-1pc (Busbar connection)
		1R-LE	1	M4-8L-1 pcs (Fixing on mounting block) up to 50A
		1S-LE	1	
		1S-LE	1	
		1T-LE	1	
	Branching bar	1R-LE10	1	M5-12L-1 pc (Busbar connection)
		1R-LE10	1	M4-8L-1 pc (Fixing on mounting block) 60~100A
		1S-LE10	1	
		1S-LE10	1	
1T-LE10		1		

Note: * The number required to form either single or double mounting blocks for 3-pole construction

Note: Specify 2-pole or 3-pole

Connections and Mountings

85-101

- **Types of connections and mountings** 86-89
- **Compression terminals** 90-91
- **Terminal screw sizes and standard torques** 92-93
- **Insulating distance from line end** 94
- **Breaker mounting screws and solderless terminals** 95
- **Standard arrangement for plug-in auxiliary terminals** 96
- **Special environment** 97
- **Toggle operation and dimensions** 98
- **Mounting positions for trip buttons and accessories** 99
- **Internal resistance and power consumption** 100-101

6

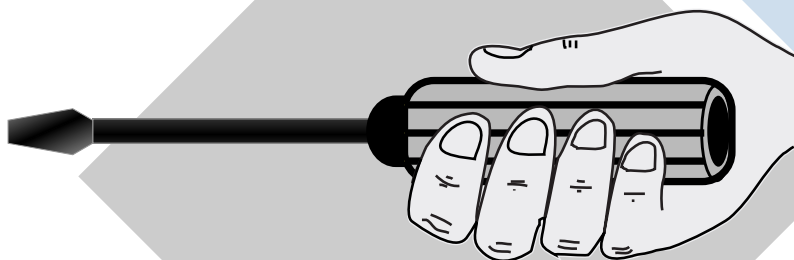

6

Connections and Mountings

Types of Connections and Mountings

Front connected type (FC)

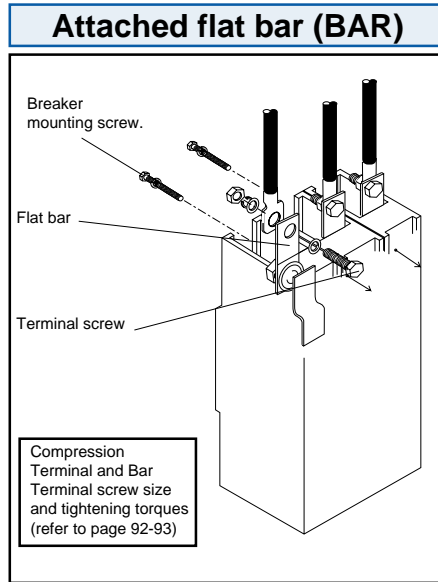
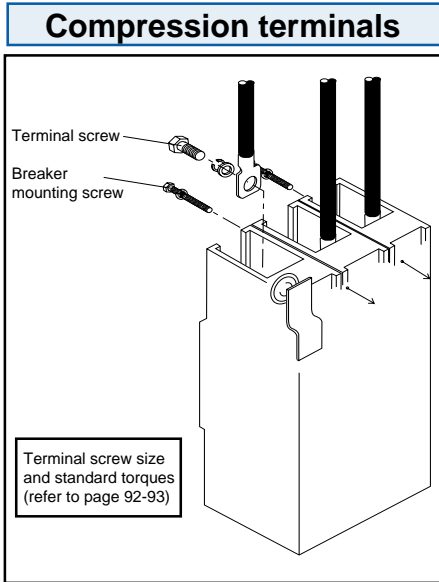

• Types of terminal screws (Compression terminal and bar)

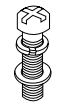
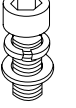
Screw type	Breaker and Screw size							
	XE Series	Screw Ø	XS Series	Screw Ø	XH Series	Screw Ø	XM Series	Screw Ø
Self up screw 	XE100NS (10-50A)	M5	XS50NB	M5			XM30PB	M5
Pan head screw 	XE100NS (60-100A)	M8	XS125CJ XS125NJ XS125CS XS125NS	M8 M8 M8 M8	XH125NJ	M8		
Hex. soc. head bolt 	XE225NS XE400NS	M8 M10	XS160NJ XS250NJ XS250PJ XS400CJ XS400NJ XS400SE-C XS400SE	M8 M8 M8 M10 M10 M10 M10	XH160NJ XH250NJ XH250PE XH400SE	M8 M8 M10 M10		

6

Connections and Mountings

Types of Connections and Mountings

Rear connected type (RC)

Bolt stud (REB)

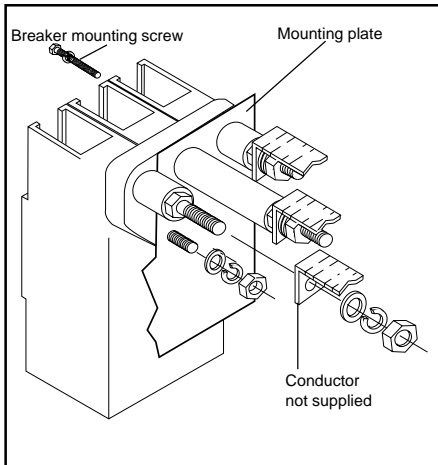

Applicable breakers

- **XE Series**
XE100NS
- **XS Series**
XS50NB
XS125CJ, XS125NJ
- **XH Series**
XH125NJ
- **XM Series**
XM30PB

Flat bar stud (90° rotation) (REF)

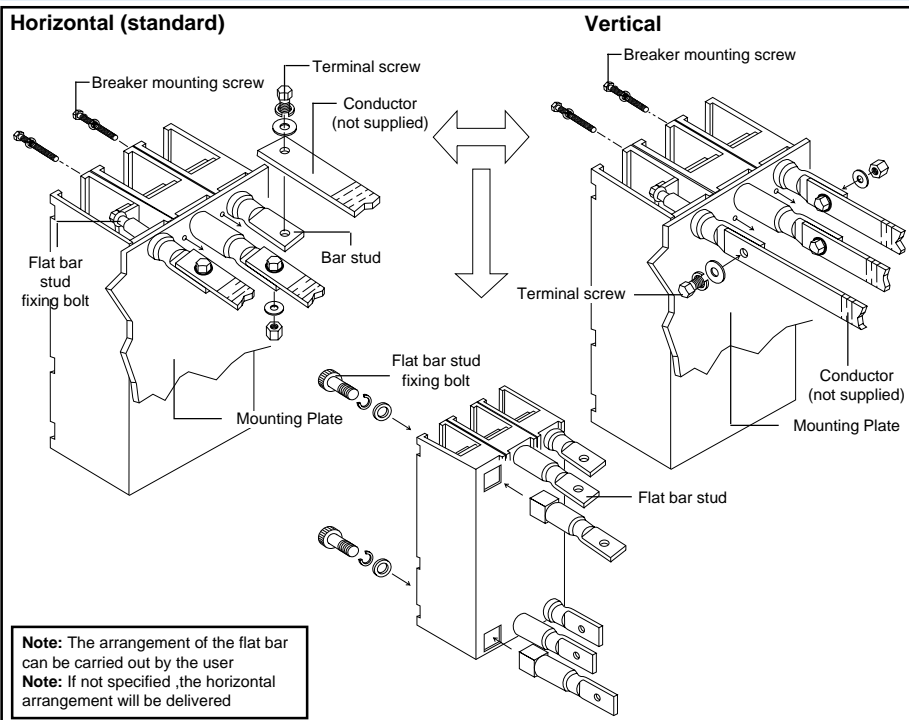

Applicable breakers

- **XE Series**
XE225NS, XE400NS, XE600NS
- **XS Series**
XS160NJ, XS250PJ, XS250NJ, XS400CJ,
XS400NJ, XS400SE-C, XS400SE, XS630CJ,
XS630NJ, XS630SE-C, XS630SE, XS800NJ
- **XS Series (cont.)**
XS800SE
- **XH Series**
XH160NJ, XH250NJ, XH250PE, XH400SE,
XH630SE, XH800PS, XH800SE

Flat bar stud (REF)

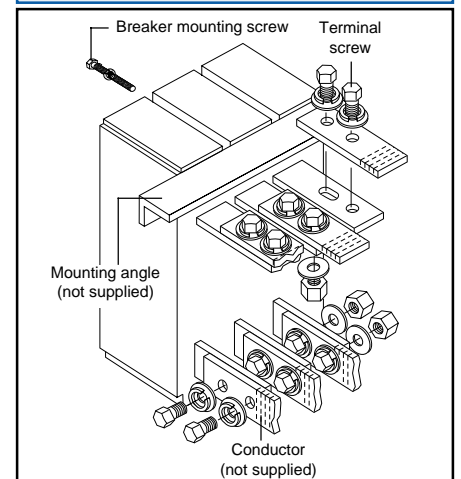

Applicable breakers

- Horizontal: * XS1250SE
 Vertical : XS1600SE, XS2000NE,
 XS2500NE

Note: *Vertical arrangements also available on request, contact Terasaki for details.

6

Connections and Mountings

Types of Connections and Mountings

Plug-in type

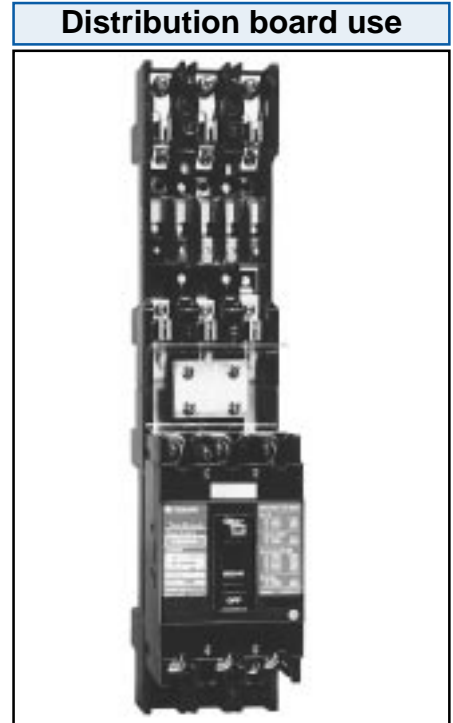
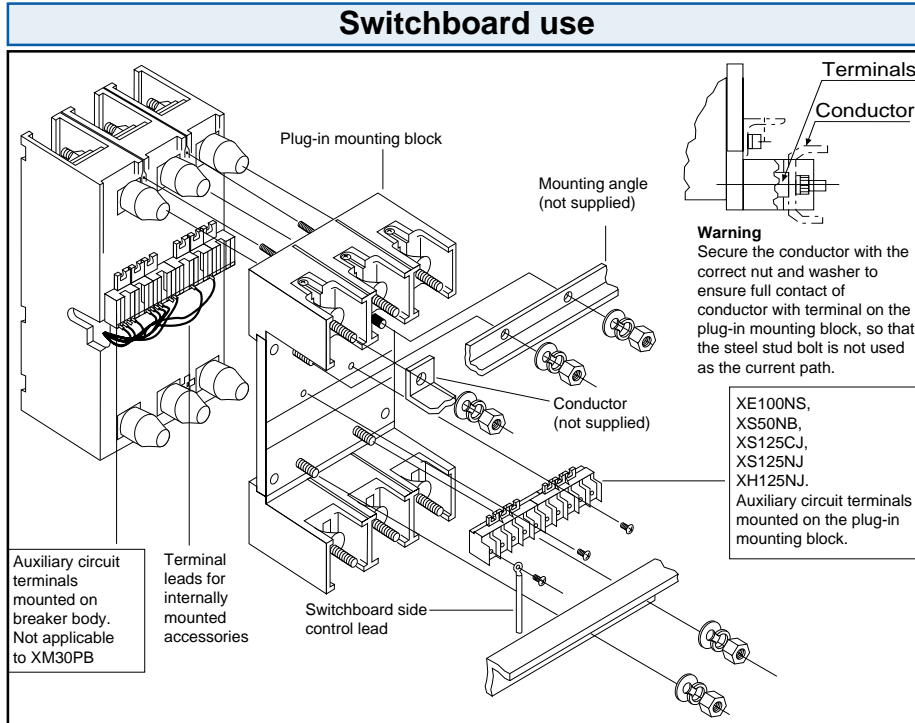

Types of plug-in mounting blocks (PMB), for switchboard use

Series	Breaker	Pole	Type
XE	XE100NS	2,3	XDM1
XS	XS50NB	2,3	XDM1
	XS125CJ	3,4	XDM2
	XS125NJ		
	XS160NJ	3,4	XDM3
	XS250PJ		
	XS400CJ	3,4	XDM4
	XS400NJ		
	XS400SE-C		
	XS400SE		
	XS630CJ	3,4	XDM6
	XS630NJ		
	XS630SE-C		
	XS630SE		
	XS800NJ		
	XS800SE		
	XS1250SE	3,4	XDM8

Series	Breaker	Pole	Type
XH	XH125NJ	3,4	XDM2
	XH160NJ	3,4	XDM3
	XH250NJ		
	XH400SE	3,4	XDM4
	XH630SE	3,4	XDM6
	XH800SE		
	XH800PS,		
XM	XM30PB	3	TDM-1DRB

(Distribution board use)

Series	Breaker	Pole	Type
XE	XE100NS	2,3	XDA1
XS	XS50NB	2,3	XDA1
	XS125CJ	3,4	XDA2
	XS125NJ		
XH	XH125NJ	3	XDA2

Note: Plug-in mounting block for distribution board (Refer to Section 5, Pages: 82-83)

IP20 Protection (Optional)

IP-20 degree of protection and safety trip are available for plug-in type breakers, for switchboard and distribution board use. IP-20 as defined in IEC Pub. 529.

Safety Trip (standard)

(Trip first, plug-in mechanism)

The breaker will trip automatically, if it is withdrawn while still in the 'ON' position. It is not possible to "plug-in" the breaker when it is in the 'ON' position.

Note: This is applicable to the XS and XH series of breakers of 125 Amp frame and larger.

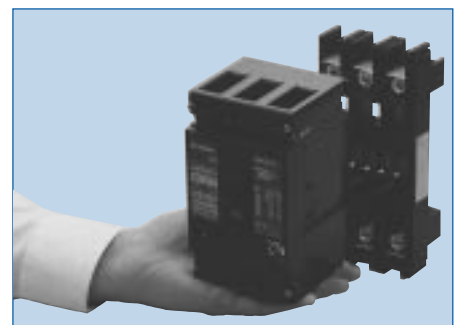
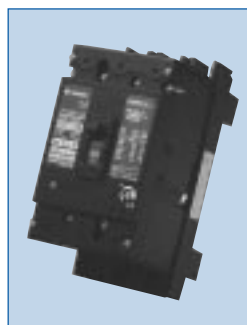
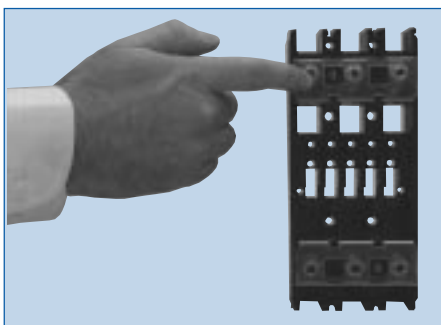

6

Connections and Mountings

Types of Connections and Mountings

Draw-out type (DO)

Two-position type

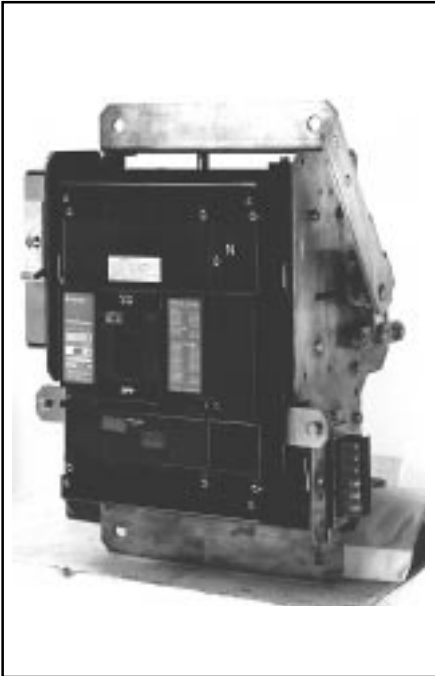

Applicable breakers

- **XS Series**
XS250PJ, XS400CJ, XS400NJ, XS400SE-C
XS400SE, XS630CJ, XS630NJ, XS630SE-C,
XS630SE, XS800NJ,
XS800SE, XS1250SE.
- **XH Series**
XH160NJ, XH250NJ, XH250PE, XH400SE,
XH630SE, XH800PS, XH800SE.
- The plug-in type breaker is housed in the draw-out cradle.
- The draw out cradle has two positions "Connected" and "Isolated".
- The auxiliary circuits are automatically connected or isolated by the auxiliary circuit terminals on the plug-in breaker. Manual connector type is available on request. When a motor operator is fitted, the circuits are manually connected (manual connector type).
- Safety Trip (first trip draw out mechanism). The breaker will trip automatically if it is drawn out while still in the "on" position.
- Position keylock in isolated position (optional) available on request.
- Position switch (1ab) in Connected position (optional) available on request.
- IP-20 degree of protection (Standard)

Three-position type



Applicable breakers

- **XS Series**
XS1600SE, XS2000NE.
- The draw out cradle has three positions "Connected", "Test" and "Isolated".
- The auxiliary circuits are automatically connected and isolated by the disconnect contacts. The auxiliary circuits are as follows: Connected in "Connected" and "Test" positions and isolated in the "Isolated" position.
- Safety shutters are available (optional) which automatically cover the live parts on the cradle side in the isolated position.
- Safety trip (trip first, draw-out mechanism)
The breaker will trip automatically if it is drawn out while still in the "ON" position.

6

Connections and Mountings Compression Terminals

Front connected type (without attached flat bar)

Frame (A)	Breaker	Nominal wire size (mm ²)													
		1.5	2.5	4	6	10	16	25	35	50	70	95	120	150	
50	XS50NB	YAV14-M5 2-5 41005 A06-M5	YAV14-M5 2-5 41015 A06-M5	YAV10-M5 5.5-5 41025 A1-M5	YAV10-M5 5.5-5 41035 A1-M5	YAV8C-M5 8-L5/8-5 41065 A2-M5	YAV6C-M5 14-5/14-NK5 41085 A3-M5								
100/ 125	XE100NS (10-50A)	YAV14-M5 2-5 41005 A06-M5	YAV14-M5 2-5 41015 A06-M5	YAV10-M5 5.5-5 41025 A1-M5	YAV10-M5 5.5-5 41035 A1-M5	YAV8C-M5 8-L5/8-5 41065 A2-M5	YAV6C-M5 14-5/14-NK5 41085 A3-M5	YAV4C-M5 22-5	38-S5						
	XE100NS (60-100A)	YAV14-M8 2-8 41008 A06-8	YAV14-M8 2-8 41015 A06-8	YAV10-M8 5.5-8 41028 A1-M8	YAV10-M8 5.5-8 41038 A1-M8	YAV8C-M8 8-8 41068 A2-M8	YAV6C-M8 14-8 41088 A3-M8	YAV4C-M8 22-8 41108 A5-M8	38-S8 41128	41138					
	XS125CJ XS125CS XS125NJ XS125NS XH125NJ	YAV14-M8 2-8 41008 A06-8	YAV14-M8 2-8 41015 A06-8	YAV10-M8 5.5-8 41028 A1-M8	YAV10-M8 5.5-8 41038 A1-M8	YAV8C-M8 8-8 41068 A2-M8	YAV6C-M8 14-8 41088 A3-M8	YAV4C-M8 22-8 41108 A5-M8	YAV2C-M8 38-S8 41128 A7-M8	41138					
160/ 225/ 250	XS160NJ XE225NS XS250NJ XS250PJ XH160NJ XH250NJ XH250PE								YAV2C-M8 38-S8 41128 A7-M8	YAV1C-M8 60-8 41138 A10-M8	41158 A14-M8		A19-M8/19	A24B- M8/19	A30B- M8/19
400	XE400NS XS400CJ XS400NJ XS400SE-C XS400SE XH400SE								YAV2C-M10 38-10 41129 A7-M10	YAV1C-M10 60-10 41139 A10-M10	YAV26-M10 70-10 41159 A14-M10	YAV27-M10 80-10 41179 A19-M10	41199 A24B- M10/19	41209 A30B- M10/19	

*(EXAMPLE)

Bicc	YAV2C-M10
Takbro	38-10
Erma (Sunleigh)	41129
Cembre	A7-M10

 **Note:** Commercially made compression terminals (refer to coloured boxes).

* Codes correct at time of printing

6

Connections and Mountings Compression Terminals

Front connected type (with attached flat bar)

Frame (A)	Breaker	Conductor size (mm ²)								
		35	50	70	95	120	150	185	240	300
160/225/ 250	XE225NS	YAV2C-M10	YAV1C-M10	YAV26-M10*	YAV27-M10*	YAV28-M10*	41209 A30B- M10/19			
	XS160NJ	38-10	60-10	70-10*	80-10*	100-10*				
	XS250PJ	41129	41139	41159	41179	41199				
	XH160NJ	A7-M10	A10-M10	A14-M10	A19-M10*	A24-M10*				
	XH250NJ									
400	XH250PE	YAV2C-M12	YAV1C-M12	YAV26-M12	YAV27-M12	YAV28-M12	150-12 41204 A30-M12	180-12 41414 A37-M12	A48-M12	
	XE400NS	38-12	60-12	70-12	80-12	100-12				
	XS400CJ	41124	41134	41154	41174	41194				
	XS400NJ	A7-M12	A10-M12	A14-M12	A19-M12	A24-M12				
	XS400SE-C									
	XS400SE									
600/630	XE600NS	YAV2C-M12	YAV1C-M12	YAV26-M12	YAV27-M12	YAV28-M12	150-12 41204 A30-M12	180-12 41414 A37-M12	200-12 41724 A48-M12	41734 A60-M12
	XS630CJ	38-12	60-12	70-12	80-12	100-12				
	XS630NJ	41124	41134	41154	41174	41194				
	XS630SE-C	A7-M12	A10-M12	A14-M12	A19-M12	A24-M12				
	XS630SE									
800	XH630SE						150-12 41204 A30-M12	180-12 41414 A37-M12	200-12 41724 A48-M12	41734 A60-M12
	XS800NJ	YAV2C-M12	YAV1C-M12	YAV26-M12	YAV27-M12	YAV28-M12				
	XS800SE	38-12	60-12	70-12	80-12	100-12				
	XH800PS	41124	41134	41154	41174	41194				
1250	XH800SE	A7-M12	A10-M12	A14-M12	A19-M12	A24-M12	150-12 41204 A30-M12	180-12 41414 A37-M12	200-12 41724 A48-M12	41734 A60-M12
	XS1250SE			YAV26-M12	YAV27-M12	YAV28-M12				
				70-12	80-12	100-12				
				41154	41174	41194				
				A14-M12	A19-M12	A24-M12				

Note: *Use interpole barriers

 Commercially made compression terminals

Connections

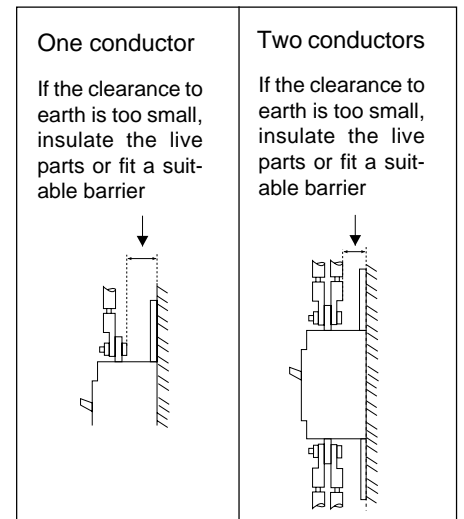

6

Connections and Mountings

Terminal Screw Sizes and Standard Torques

Types

Front connection (FCS)

Rear connection bolt stud (REB)

Compression terminal bar Terminal bar

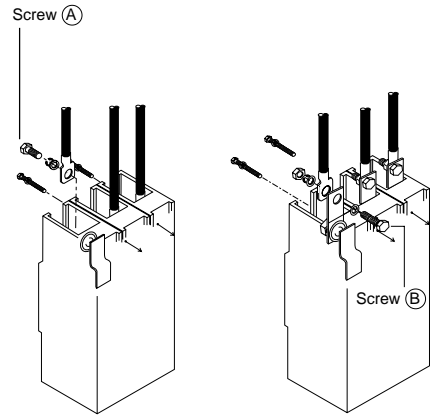

Breakers up to 100A frame.

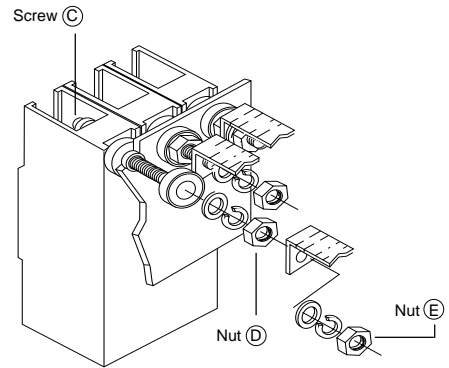

Frame (A) Breaker	Screw size (A)	Torque N-m	Screw Size (B)	Torque N-m	Screw size (C)	Torque N-m	Nut dia. (D)	Torque N-m	Nut dia. (E)	Torque N-m
30 XM30PB	(i)M5x12	2.30-3.40	-	-	(i) M4x12	1.1-1.7	-	-	(ii)M6	2.7-4.5
50 XS50NB	(i)M5x12*	2.34-3.57	-	-	(i) M4x12	1.12-1.73	-	-	(ii)M6	2.85-4.69
100/125 XE100NS	10-50A (i)M5x12 *	2.34-3.57	-	-	(i) M4x14	1.12-1.73	-	-	(ii)M6	3.77-6.22
	60-100A (i)M8x14	7.14-9.69	-	-	(ii) M6 nut	3.77-6.22	-	-	(ii)M8	7.14-11.22
XS125CJ	(i)M8x14	7.14-9.69	-	-	(iii)M6x16	2.34-4.08	-	-	(ii)M8	7.14-11.22
XS125CS	-	-	-	-	-	-	-	-	-	-
XS125NJ	-	-	-	-	-	-	-	-	-	-
XS125NS	-	-	-	-	-	-	-	-	-	-
XH125NJ	-	-	-	-	-	-	-	-	-	-
160/225 XE225NS	(iii)M8x20	9.18-15.3	(ii)M10x25	23.46-38.76	-	-	-	-	-	-
250 XS160NJ	-	-	-	-	-	-	-	-	-	-
XS250NJ	-	-	-	-	-	-	-	-	-	-
XS250PJ	-	-	-	-	-	-	-	-	-	-
XH160NJ	-	-	-	-	-	-	-	-	-	-
XH250NJ	-	-	-	-	-	-	-	-	-	-
XH250PE	(iii)M10x30	14.28-23.46	(ii)M12x35	41.82-68.34	-	-	-	-	-	-
400 XE400NS	(iii)M10x30	14.28-23.46	(ii)M12x35	41.82-68.34	-	-	-	-	-	-
XS400CJ	-	-	-	-	-	-	-	-	-	-
XS400NJ	-	-	-	-	-	-	-	-	-	-
XS400SE-C	-	-	-	-	-	-	-	-	-	-
XS400SE	-	-	-	-	-	-	-	-	-	-
XH400SE	-	-	-	-	-	-	-	-	-	-
600/630 XE600NS	-	-	(ii)M12x40	41.82-68.34	-	-	-	-	-	-
XS630CJ	-	-	-	-	-	-	-	-	-	-
XS630NJ	-	-	-	-	-	-	-	-	-	-
XS630SE-C	-	-	-	-	-	-	-	-	-	-
XS630SE	-	-	-	-	-	-	-	-	-	-
XH630SE	-	-	-	-	-	-	-	-	-	-
800 XS800NJ	-	-	(ii)M12x40	41.82-68.34	-	-	-	-	-	-
XS800SE, XH800PS	-	-	-	-	-	-	-	-	-	-
XH800SE	-	-	-	-	-	-	-	-	-	-
1250 XS1250SE	-	-	(ii)M12x55	41.82-68.34	-	-	-	-	-	-
1600 XS1600SE	-	-	(ii)M12x60	41.82-68.34	-	-	-	-	-	-
2000 XS2000NE	-	-	(ii)M10x60	23.46-38.76	-	-	-	-	-	-
2500 XS2500NE	-	-	-	-	-	-	-	-	-	-

Note: Connecting bolts are not attached to breakers of 1600A and larger frame sizes

* Self-up screw

(i) Pan head

(ii) Hex. bolt

(iii) Hex. socket head bolt

Note: Units: mm for screws

N/m for torque

6

Connections and Mountings

Terminal Screw Sizes and Standard Torques

Rear connection flat bar stud (REF)

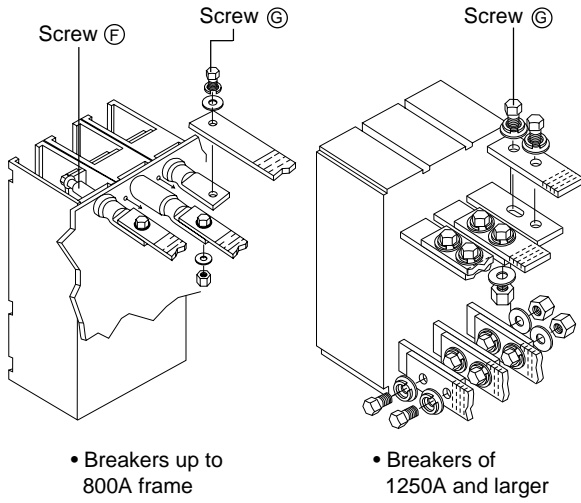

Plug-in type

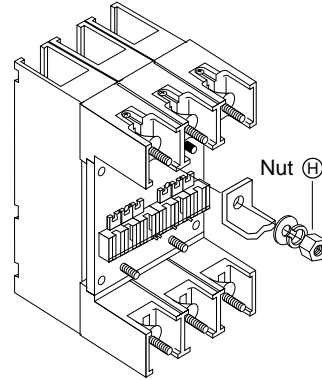

Draw-out type

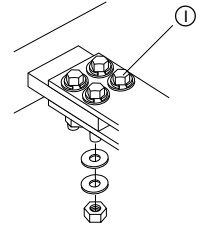

Screw (F)	Torque N-m	Screw (G)	Torque N-m	Nut (H)	Torque N-m	Screw (I)	Torque N-m
-	-	-	-	(i)M5x8**	22.00-36.00	-	-
-	-	-	-	(ii)M6	3.77-6.22	-	-
-	-	-	-	(ii)M6	3.77-6.22	-	-
-	-	-	-	(ii)M6	3.77-6.22	-	-
-	-	-	-	(ii)M6	3.77-6.22	-	-
(iii) M6x20	3.774-6.222	(ii) M8x25	12.24-9.18	(ii)M8	9.18-15.3	-	-
(iii) M10x40	19.38-30.6	(ii) M12x35	41.82-68.34	(ii)M10	19.38-30.6	**	**
(iii) M10x40	19.38-30.6	(ii) M12x35	41.82-68.34	(ii)M10	19.38-30.6	**	**
(iii) M10x27 (Special)	19.38-30.6	(ii) M12x40	41.82-68.34	(ii) M16	53.55-87.72	**	**
(iii) M 10x27 (Special)	19.38-30.6	(ii) M12x40	41.82-68.34	(ii) M16	53.55-87.72	**	**
-	-	(ii) M12x50	41.82-68.34	(ii) M12x50	41.82-68.34	**	**
-	-	(ii) M10x45	23.46-38.76	-	-	(ii) M10x45	23.46-38.76
-	-	(ii) M10x60	23.46-38.76	-	-	(ii) M10x60	23.46-38.76
-	-	(ii) M10x60	23.46-38.76	-	-	-	-

Note: ** Breakers from 400A to 1250A frame are the same as those for Plug-in types
 (i) Pan head
 (ii) Hex. bolt
 (iii) Hex. socket head bolt

6

Connections and mountings Insulating Distance from Line-end

When earthed metal is installed within the proximity of the breakers the correct insulating distance must be maintained (refer to Table 1). This distance is necessary to allow the exhausted arc gases to disperse.

WARNING: EXPOSED CONDUCTORS MUST BE INSULATED TO AVOID POSSIBLE SHORT CIRCUITING OR EARTHING DUE TO FOREIGN MATTER COMING INTO CONTACT WITH THE CONDUCTORS.

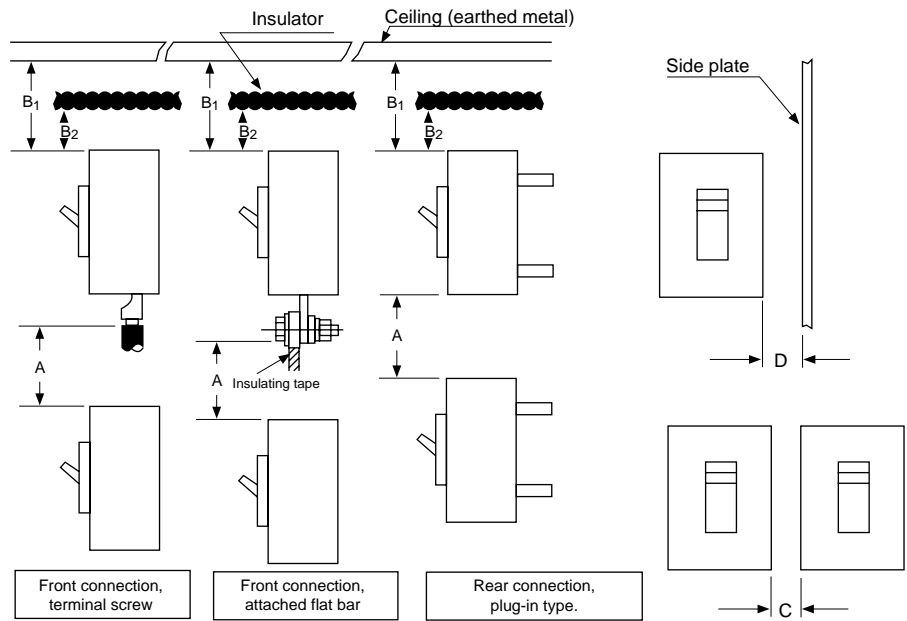

- A : Distance (refer to Table 1) from lower breaker to open charging part of terminal on upper breaker (front connection) or the distance from lower breaker to upper breaker end (rear connection and plug-in type).
- B1 : Distance from breaker end to ceiling (earthed metal)
- B2 : Distance from breaker end to insulator
- C : Clearance between breakers
- D : Distance from breaker side to side plate (earthed metal)

This table is valid for 380/415V

Table 1

Series	Breaker	A	B1	B2	C	D	
XE	XE100NS	75	45	25	0	25	
	XE225NS	80	50	30	0 (30)	25 (33)	
	XE400NS	100	70	40	0 (46)	25 (34)	
	XE600NS	120	70	40	0	30	
	XS50NB	75	45	25	0	25	
XS	XS125CS, XS125NS XS125CJ, XS125NJ	80	60	30	0 (30)	25 (33)	
	XS160NJ XS250NJ XS250PJ	100	70	40	0 (46)	30 (34)	
	XS400CJ XS400NJ, XS400SE-C XS400SE	120	70	40	0	30	
	XS630CJ, XS630NJ XS630SE-C, XS630SE XS800NJ, XS800SE	150	70	40	0	30	
	XS1250SE	150	150	100	0	100	
	XS1600SE XS2000NE XS2500NE	75	45	25	0	25	
	XH	XH125NJ	100	80	60	0 (30)	25 (33)
		XH160NJ, XH250NJ	120	70	40	0 (46)	30 (34)
		XH250PE, XH400SE	150	80	50	0	40
		XH630SE, XH800SE	150	150	100	0	20
XM	XH800PS	30	10	10	0	25	
	XM30PB						

Note: Figures in brackets apply when attach bars are fitted.

6

Connections and mountings

Breaker Mounting Screws and Solderless Terminals

Breaker Mounting Screws

Series	Breaker	Pole	Front connection		Rear connection		Plug-in	
			*Screw size	Qty	Screw size	Qty	Screw size	Qty
XE	XE100NS	2,3	(i)M4x65	2	(i)M4x65	2	(i)M4x65	2
	XE225NS	3	(i)M4x40	4	(i)M4x40	4	–	–
	XE400NS	3	(i)M6x45	4	(i)M6x45	4	**	4
	XE600NS	3	(i)M8x45	4	(i)M8x45	4	**	4
XS	XS50NB	2,3	(i)M4x65	2	(i)M4x65	2	(i)M4x65	2
	XS125CJ	3,4	(i)M4x35	2	(i)M4x35	2	(i)M4x35	2
	XS125NJ	3,4	(i)M4x35	4	(i)M4x35	4	(i)M4x35	4
	XS125CS, XS125NS	1	(i)M4x80	2	(i)M4x80	2	(i)M4x80	2
	XS160NJ, XS250NJ	3,4	(i)M4x40	4	(i)M4x40	4	(i)M4x40	4
	XS250PJ	3,4	(i)M4x60	4	(i)M4x60	4	(i)M4x60	4
	XS400NJ	3,4	(i)M6x45	4	(i)M6x45	4	**	4
	XS400SE-C, XS400SE							
	XS630CJ, XS630NJ	3,4	(i)M8x45	4	(i)M8x45	4	**	4
	XS630SE-C, XS630SE							
	XS800NJ, XS800SE							
	XS1250SE	3,4	(i)M8x50	4	(i)M8x50	4	**	4
	XS1600SE	3,4	(i)M8x50	4	(i)M8x50	4	–	–
	XS2000NE	3,4	(iii)M10x160	4	(iii)M10x120	4	–	–
XS2500NE	3,4	–	–	(iii)M10x120	4	–	–	
XH	XH125NJ	3	(i)M4x35	2	(i)M4x35	2	(i)M4x35	2
		4	(i)M4x35	4	(i)M4x35	4	(i)M4x35	4
	XH160NJ, XH250NJ	3,4	(i)M4x60	4	(i)M4x60	4	(i)M4x60	4
	XH250PE, XH400SE	3,4	(i)M6x45	4	(i)M6x45	4	**	4
	XH630SE, XH800PS	3,4	(i)M8x45	4	(i)M8x45	4	**	4
XH800SE								
XM	XM30PB	3	(i)M4x65	2	–	–	(i)M4x65	2

Note: * Screw size is for tapped hole

** Captive nuts

(i) Pan head

(iii) Hex. socket head

Solderless Terminals

Series	Breaker	Pole	Cable size	Torque N/m cable connection	Torque N/m solderless terminal
XE	XE100NS (60-100A)	2, 3	50mm ²	5.64	2.35 ~ 3.43
	XE225NS	3	150mm ²	28.22	6.86 ~ 9.31
		4			
	XE400NS	3	240mm ² or 2x 120mm ²	28.22	6.86 ~ 9.31
XS	XS50NB	2, 3	25mm ²	5.64	2.35 ~ 3.43
	XS125CJ/XS125NJ	3	70mm ²	5.64	2.35 ~ 3.43
		4			
	XS160NJ/XS250NJ	3	150mm ²	28.22	6.86 ~ 9.31
	XS250PJ				
	XS160NJ/XS250NJ	4			
	XS250PJ				
	XS400CJ/XS400NJ	3	240mm ² or 2x 120mm ²	28.22	6.86 ~ 9.31
	XS400SE-C/XS400SE				
	XS400CJ/XS400NJ	4			
XS400SE-C/XS400SE					
XH	XH125NJ	3	70mm ²	5.64	2.35 ~ 3.43
		4			
	XH160NJ/XH250NJ	3	150mm ²	28.22	6.86 ~ 9.31
		4			
	XH250PE/XH400SE	3	240mm ² or 2x 120mm ²	28.22	6.86 ~ 9.31
	4				

6

Connections and Mountings

Standard Arrangement for Plug-in Type Auxiliary Circuit Terminals (LTP)

The arrangements shown below represent the view from the rear of the breaker. Refer to figure 1, page 97.

Frame (A)		30-250A Frame	400A Frame	600-1250A Frame
Number of auxiliary terminals to be installed (maximum)				
SHT	LINE			
	LOAD			
UVT	LINE			
	LOAD			
1AB	LINE			
	LOAD			
2AB	LINE			
	LOAD			
3AB	LINE			
	LOAD			
SHT & 1AB	LINE			
	LOAD			
SHT & 2AB	LINE	*		
	LOAD			
SHT & 3AB	LINE			
	LOAD			
UVT & 1AB	LINE			
	LOAD			
UVT & 2AB	LINE	*		
	LOAD			
UVT & 3AB	LINE			
	LOAD			
ALT & 1AB	LINE	†		
	LOAD			
ALT & 2AB	LINE	*		
	LOAD			
UVT & ALT & 1AB	LINE	* †		
	LOAD			
UVT & ALT & 2AB	LINE		†	†
	LOAD			
SHT & ALT & 1AB	LINE	* †		
	LOAD			
SHT & ALT & 2AB	LINE		†	†
	LOAD			
ALT	LINE			
	LOAD			
SHT & ALT	LINE			
	LOAD			
UVT & ALT	LINE			
	LOAD			

* : Connections not terminated on plug-in aux.circuit terminal, will be terminated either on UVT controller or Auxiliary Lead Terminal Block (breaker mounted, refer to page 78-79)

† : Alarm switch is an 'a' contact only

Note 1 : DC UVT without controller will have terminals U₁ and U₂

Note 2 : Due to restricted space, these terminals are common

6

Special Applications Special Environment

Special breakers are designed and built to be used under standard operating conditions. Breakers required for conditions other than standard are available on request. Please specify when ordering.

Standard operating conditions are in accordance with IEC 947-2

Operating ambient temperature - 5° C to 40° C

When a thermal magnetic breaker is used at a temperature exceeding its calibrated temperature of 40°c, 45°c or 50°c, the operating current should be reduced in accordance with ambient compensation curves, section 3. Please contact Terasaki for temperature performance details of microprocessor protected breakers.

Relative humidity 85% max

Altitude 2,000m max

Note:*Atmosphere should not contain dust, smoke, corrosive gases, inflammable gases, moisture or salt.

Special environment	Specification	Nameplate indication
Low Temperature Breaker	This is specially treated for storage and use at low temperature. The lowest limit is -40° C for storage and -20° C for use. The breaker is calibrated at 40° C or, 45° C for marine use and requires an appropriate adjustment of the specified characteristics. At low temperatures the environment must be free from rapid temperature changes that result in condensation forming or freezing of the breaker.	PROOFED FOR LOW TEMPERATURE Storage -40° C or higher Operation - 20° C or higher
Tropicalization (fungus moisture proof) Breaker	The dielectric strength and other electrical properties of insulating materials that are likely to deteriorate at high temperature and high humidity. The tropicalised breaker uses specially selected materials and special surface treatment for such conditions. Note: The maximum conditions for use are 60° C ambient and 95% relative humidity provided that there are no rapid changes in temperature likely to occur. Contact Terasaki for details.	TROPICALISATION Fungus moisture proof
Corrosive Resistant Breaker	The corrosive resistant breaker is specially surface treated for increased corrosion resistance. Note: If the breaker is to be used in an atmosphere that has an excess of corrosive gases or moisture and salt then the breaker must be housed in an air tight box, container or cabinet.	CORROSIVE RESISTANT

Standard arrangement for plug-in type auxiliary circuit terminals (LTP) contd.

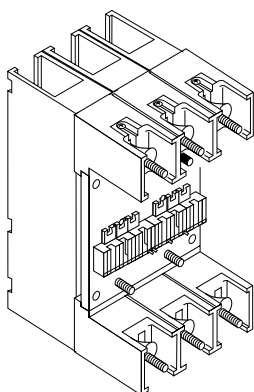
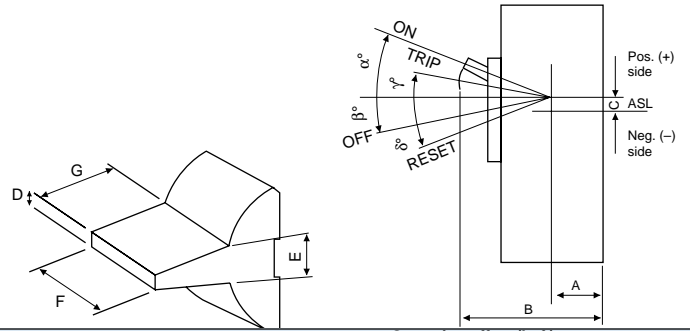

Figure 1

Page 96 refers to view on this arrow

6

Toggle Operation and Dimensions



Frame (A)	Breaker	Operation angles				Dimensions (mm)							Operation effort (kgf.)			
		On	Off	Trip	Reset	A	B	C	D	E	F	G	Off	On	Trip	Radius
		α°	β°	γ°	δ°											
30	XM30PB	17	7	6.5	12	62.8	117	+3	6	7	10	15.5	19.6	9.8	39.2	54.2
50	XS50NB	17	7	6.5	12	32.8	87	+3	6	7	10	15.5	2.0	1.0	4.0	54.2
100/125	XE100NS	17	7	6.5	12	32.8	87	+3	6	7	10	15.5	2.0	1.0	4.0	54.2
	XS125CJ	17	4	9	9.5	48.5	104	-2	7	8	10.5	18	1.9	1.1	4.5	55.5
	XS125NJ XH125NJ															
160/225/250	XE225NS	20.5	5.5	10.5	8.5	38	107	-7.5	7.5	8	10	22.7	4.2	3.0	7.0	69
	XS160NJ XS250NJ XS250PJ XH160NJ XH250NJ					55	124									
	XH250PE	20.2	11	10.5	17.4	48	145	-3	14	12.5	24.5	41.5	8.8	12	10.2	97
	XS400NS XS400CJ XS400NJ XS400SE-C XS400SE XH400SE	20.2	11	10.5	17.4	48	145	-3	14	12.5	24.5	41.5	8.8	12	10.2	97
600/630	XE600NS	20	8.5	11	10.5	43.2	144	-6.8	11	12.5	40	33	12.3	15	24	100.8
	XS630CJ XS630NJ XS630SE-C XS630NE XH630NE															
	XS800NJ XS800SE XH800PS XH800SE	20	8.5	11	10.5	43.2	144	-6.8	11	12.5	40	33	12.3	15	24	100.8
	XS1250SE	22	4	12	9	73.5	171.8	-2.8	11	12.5	40	30	16	30	35	98.3
1600	XS1600SE	22	4	12	9	93.5	191.8	-2.8	11	12.5	40	30	16	30	35	98.3
2000	XS2000NE	18.3	10	7.7	15.3	100	245	+2	20.5	24	60	42.5	39	32.9	57	146
2500	XS2500NE	18.3	10	7.7	15.3	100	245	+2	20.5	24	60	42.5	39	32.9	57	146

6

Mounting Positions for Trip Button and Externally Mounted Accessories

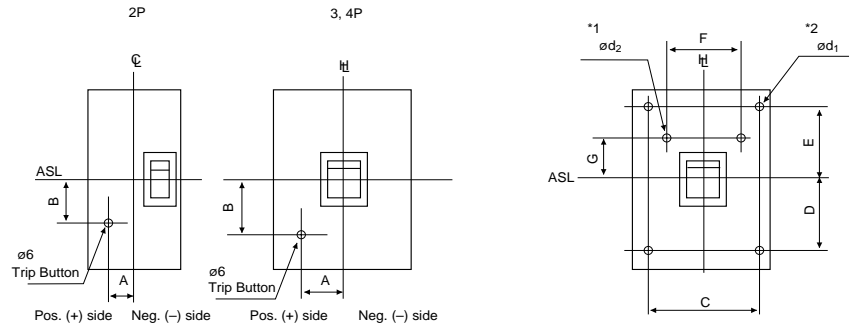

Frame (A)	Breaker	Poles	Trip button		Diameter					Lower hole			
			A	B	C	D	E	F	G	ød ₁	Depth	ød ₂	Depth
30	XM30PB	3	-31.5	28	-	-	-	-	-	-	-	-	-
	50	XS50NB	2	+20	28	-	-	-	-	-	-	-	-
100/125		XE100NS	3	-31.5	28	-	-	-	-	-	-	-	-
	2		+20	28	-	-	-	-	-	-	-	-	
	3	-31.5	28	-	-	-	-	-	-	-	-	-	
160/225/250	XS125CJ	3	+30.5	34.5	83.4	68	68	-	-	41.5	6.7	-	-
	XS125NJ	4	-	-	113.4	-	-	-	-	-	-	-	-
	XH125NJ	4	-	-	-	-	-	-	-	-	-	-	-
	XE225NS	3	+22.5	37.5	93	75	75	-	-	4.15	6.7	-	-
	XS160NJ	4	-	-	128	-	-	-	-	-	-	-	-
	XS250NJ	4	-	-	-	-	-	-	-	-	-	-	-
400	XS250PJ	4	-	-	-	-	-	-	-	-	-	-	-
	XH160NJ	4	-	-	-	-	-	-	-	-	-	-	-
	XH250NJ	4	-	-	-	-	-	-	-	-	-	-	-
	XH250PE	3	+32	81	128	118	118	105	62	4.65	8.5	5.65	6
	XE400NS	3	+32	81	128	118	118	105	62	4.65	8.5	5.65	6
	XS400CJ	4	-	-	173	-	-	-	-	-	-	-	-
600/630	XS400NJ	4	-	-	-	-	-	-	-	-	-	-	-
	XS400SE-C	4	-	-	-	-	-	-	-	-	-	-	-
	XS400SE	4	-	-	-	-	-	-	-	-	-	-	-
	XH400SE	4	-	-	-	-	-	-	-	-	-	-	-
	XE600NS	3	+15	74	90	125.5	134.5	105	73	4.65	5.1	5.65	6
	XS630CJ	4	-	-	160	-	-	-	-	-	-	-	-
800	XS630NJ	4	-	-	-	-	-	-	-	-	-	-	-
	XS630SE-C	4	-	-	-	-	-	-	-	-	-	-	-
	XS630NE	4	-	-	-	-	-	-	-	-	-	-	-
	XH630NE	4	-	-	-	-	-	-	-	-	-	-	-
1250	XS800NJ	3	+15	74	90	125.5	134.5	105	73	4.65	5.1	5.65	6
	XS800SE	4	-	-	160	-	-	-	-	-	-	-	-
1600	XH800PS	4	-	-	-	-	-	-	-	-	-	-	-
	XH800SE	4	-	-	-	-	-	-	-	-	-	-	-
2000	XS1250SE	3,4	0	72.5	100	155	185	-	-	4.65	5	-	-
2000	XS1600SE	3,4	0	72.5	170	155	185	-	-	4.65	5	-	-
2000	XS2000NE	3,4	+39	126	-	-	-	-	-	-	-	-	-

6

Internal Resistance and Power Consumption

Economical series (XE)

Breaker	Rated current (A)	Internal resistance (DC mΩ)		Power consumption (DC W)	
		FC Value per pole	Plug-in	FC Value per pole	Plug-in
XE100NS	10	15.9	16.2	1.59	1.62
	15	5.7	6.0	1.28	1.35
	20	4.7	5.0	1.88	2.0
	30	3.5	3.8	3.15	3.42
	40	2.0	2.3	3.2	3.68
	50	1.6	1.9	4.0	4.75
	60	1.2	1.5	4.32	5.4
	75	1.1	1.4	6.19	7.88
	100	1.0	1.3	10.0	13.0
	XE225NS	125	0.4	0.54	6.25
150		0.4	0.54	9.0	12.2
175		0.4	0.54	12.3	16.5
200		0.18	0.32	7.2	12.8
225		0.18	0.32	9.11	16.2
XE400NS		250	0.22	0.26	13.8
	300	0.15	0.19	13.5	17.1
	350	0.15	0.19	18.4	23.3
	400	0.15	0.19	24.0	30.4
XE600NS	450	0.10	0.14	20.25	28.3
	500	0.10	0.14	25.0	35.0
	600	0.10	0.14	36.0	50.4

Standard series (XS)

Breaker	Rated current (A)	Internal resistance (DC mΩ)		Power consumption (DC W)		
		FC Value per pole	Plug-in	FC Value per pole	Plug-in	
XS50NB	10	15.9	16.2	1.59	1.62	
	15	5.7	6.0	1.28	1.35	
	20	4.7	5.0	1.88	2.0	
	30	3.5	3.8	3.15	3.42	
	40	2.0	2.3	3.2	3.68	
	50	1.6	1.9	4.0	4.75	
	XS125CJ	20	13.3	13.57	5.23	5.43
		32	6.20	6.47	6.35	6.63
		50	1.33	1.60	3.33	4.0
	XS125NJ	63	1.0	1.37	4.37	5.44
100		0.76	1.03	7.60	10.3	
125		0.73	1.0	11.4	15.6	
160		0.58	0.72	14.9	18.4	
XS250PJ	160	0.58	0.72	14.9	18.4	
	250	0.32	0.46	20.0	28.8	
XS250NJ	160	0.58	0.72	14.9	18.4	
	250	0.32	0.46	20.0	28.8	
XS400CJ	250	0.22	0.26	13.8	16.3	
	400	0.15	0.19	24.0	30.4	
XS400SE-C	125	0.14	0.18	2.19	2.81	
	150	0.14	0.18	3.15	4.10	
	175	0.14	0.18	2.89	5.50	
	200	0.14	0.18	5.60	7.20	
	225	0.14	0.18	7.09	9.11	
	250	0.14	0.18	8.75	11.3	
	300	0.14	0.18	12.6	16.2	
	350	0.14	0.18	17.2	22.1	
	400	0.14	0.18	22.4	28.8	
	XS630CJ	400	0.17	0.21	27.2	33.6
		630	0.10	0.14	39.7	55.6
	XS630SE-C	300	0.09	0.13	8.10	11.7
		350	0.09	0.13	11.0	15.9
	XS630NE	400	0.09	0.13	14.4	20.8
500		0.09	0.13	22.5	32.5	
600		0.09	0.13	32.4	46.8	
XS800NJ		800	0.07	0.11	44.8	70.4
		400	0.07	0.11	11.2	17.6
		450	0.07	0.11	14.2	22.3
	500	0.07	0.11	17.5	27.5	
XS800SE	600	0.07	0.11	25.2	39.6	
	700	0.07	0.11	34.3	53.9	
	800	0.07	0.11	44.8	70.4	
	XS1250SE	600	0.04	0.053	14.4	19.1
		700	0.04	0.053	19.6	26.0
		800	0.04	0.053	25.6	33.9
1000		0.04	0.053	40.0	53.0	
1250		0.04	0.053	57.6	76.3	
XS1600SE		800	0.022	** 0.039	14.1	25.0
	900	0.022	** 0.039	17.8	31.6	
	1000	0.022	** 0.039	22.0	39.0	
	1200	0.022	** 0.039	31.7	56.2	
	1400	0.022	** 0.039	43.1	76.4	
	1600	0.022	** 0.039	56.3	99.8	
XS2000NE	1000	0.017	** 0.022	17.0	22.0	
	1200	0.017	** 0.022	24.5	31.7	
	1400	0.017	** 0.022	33.3	43.1	
	1600	0.017	** 0.022	43.5	56.3	
	1800	0.017	** 0.023	55.1	**71.3	
	2000	0.017	** 0.023	68.0	** 88.0	
XS2500NE	1200	* 0.017	-	* 24.5	-	
	1400	* 0.017	-	* 33.3	-	
	1600	* 0.017	-	* 43.5	-	
	2000	* 0.017	-	* 68.0	-	
	2500	* 0.017	-	* 106.2	-	

Note: * Value of rear connected type breaker. ** Value of draw-out type breaker.
Note: All values are used as a guide only

6

Internal Resistance and Power Consumption

High-fault level series (XH)

Breaker	Rated current (A)	Internal resistance (DC mΩ)		Power consumption (DC W)	
		FC Value per pole	Plug-in	FC Value per pole	Plug-in
XH125NJ	20	13.3	13.57	5.32	5.43
	32	6.20	6.47	6.35	6.63
	50	1.15	1.42	2.88	3.55
	63	1.03	1.30	4.09	5.16
	100	0.75	1.02	7.50	1.02
	125	0.72	0.99	11.3	15.5
XH160NJ	160	0.57	0.71	14.5	18.2
XH250NJ	160	0.57	0.71	14.6	18.2
	250	0.32	0.46	20.0	28.8
XH250PE	125	0.014	0.18	2.19	2.81
	150	0.014	0.18	3.15	4.10
	175	0.014	0.18	2.89	5.50
	200	0.014	0.18	5.60	7.20
	225	0.014	0.18	7.09	9.11
XH400SE	125	0.14	0.18	2.19	2.81
	150	0.14	0.18	3.15	4.10
	175	0.14	0.18	2.89	5.50
	200	0.14	0.18	5.60	7.20
	225	0.14	0.18	7.09	9.11
	250	0.14	0.18	8.75	11.3
	300	0.14	0.18	12.6	16.2
	350	0.14	0.18	17.2	22.1
	400	0.14	0.18	22.4	28.8
XH630NE	300	0.09	0.13	8.10	11.7
	350	0.09	0.13	11.0	15.9
	400	0.09	0.13	14.4	20.8
	500	0.09	0.13	32.4	46.8
XH800PS	400	0.07	0.11	11.2	17.6
	450	0.07	0.11	14.2	22.3
	500	0.07	0.11	17.5	27.5
	600	0.07	0.11	25.2	39.6
	700	0.07	0.11	34.3	53.9
	800	0.07	0.11	44.8	70.4
XH800SE	400	0.07	0.11	11.2	17.6
	450	0.07	0.11	14.2	22.3
	500	0.07	0.11	17.5	27.5
	600	0.07	0.11	25.2	39.6
	700	0.07	0.11	34.3	53.9
	800	0.07	0.11	44.8	70.4

Outline Dimensions

103-117

• XM30PB	104
• XS50NB	105
• XE100NS	106
• XS125CS, XS125NS	107
• XS125CJ, XS125NJ, XH125NJ, XS125NN	108
• XS160NJ, XS160NN, XE225NS, XS250NJ, XS250NN	109
• XH160NJ, XS250PJ, XH250NJ	110
• XH250PE, XE400NS, XS400CJ, XS400NJ, XS400SE-C XS400SE, XH400SE, XS400NN	111
• XE600NS, XS630CJ, XS630NJ, XS630SE-C, XS630SE XH630SE, XS630NN, XS800NJ, XS800SE, XH800PS XH800SE, XS800NN, XS1000ND	112
• XS1250SE, XS1250NN	113
• XS1250ND	114
• XS1600SE, XS1600NN, XS1600ND	115
• XS2000NE, XS2000ND	116
• XS2500NE, XS2500ND	117

Note: Please refer to catalogue '98-T20E for outline dimensions of MCCBs & XMC type motor operators

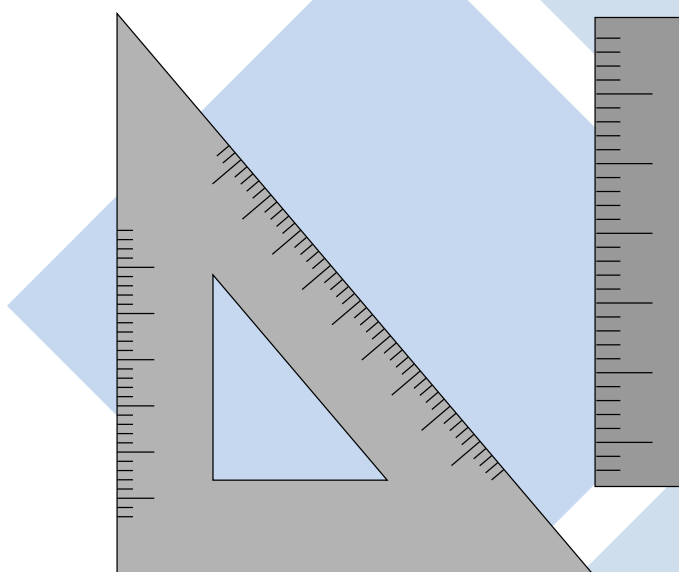



Outline dimensions (mm)

TemBreak

XM30PB

Front connected

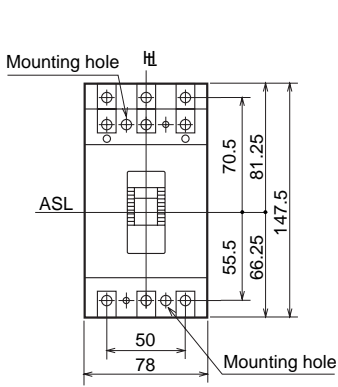

Preparation of conductor

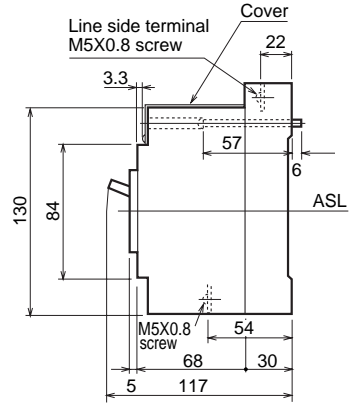

Drilling plan

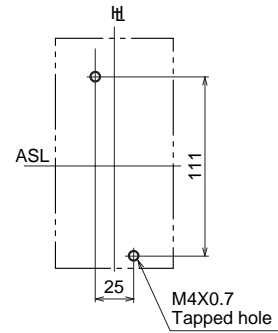

Rear connected

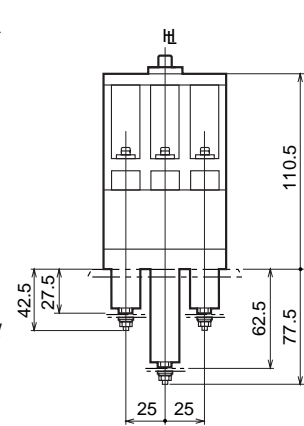
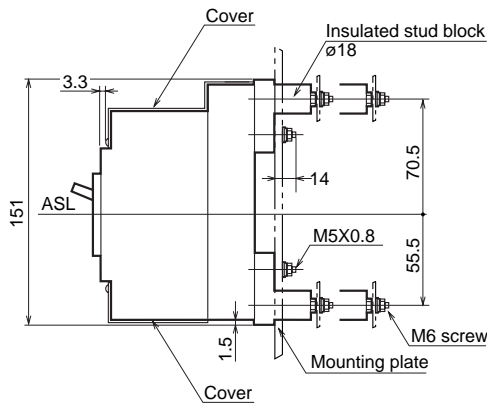

Drilling plan

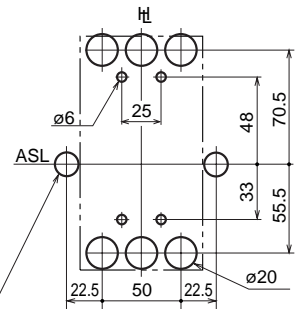

Panel cutout

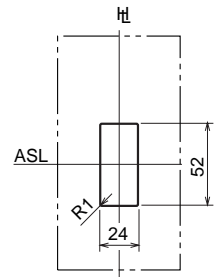

Plug-in

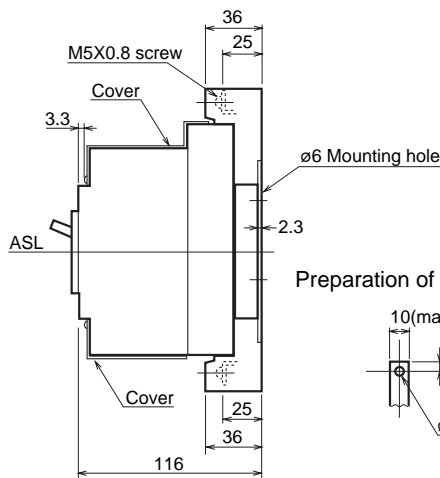
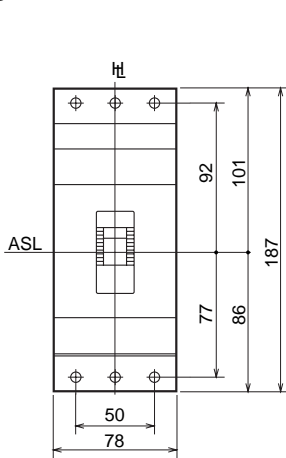

Drilling plan

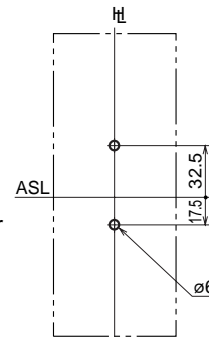



Outline dimensions (mm)

TemBreak

XS50NB

ASL: Arrangement Standard Line
HL: Handle Frame Centre Line

Front connected

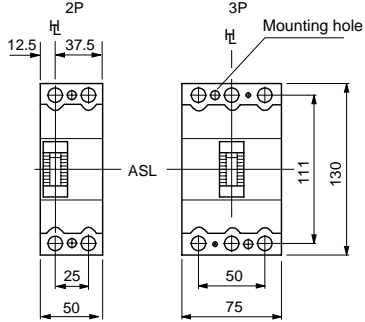

Preparation of conductor

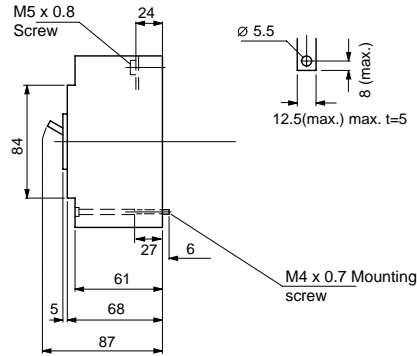

Drilling plan

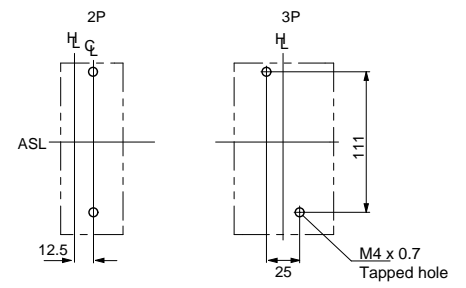

Rear connected with motor operator

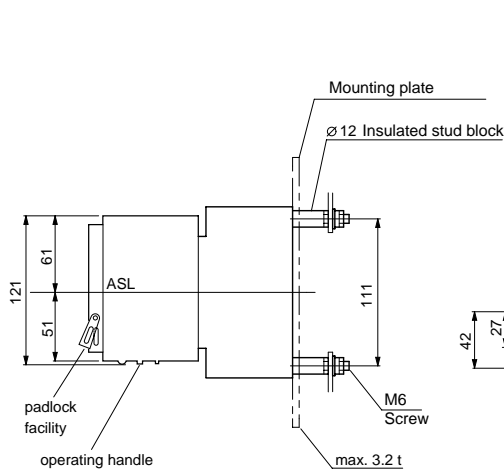

Drilling plan

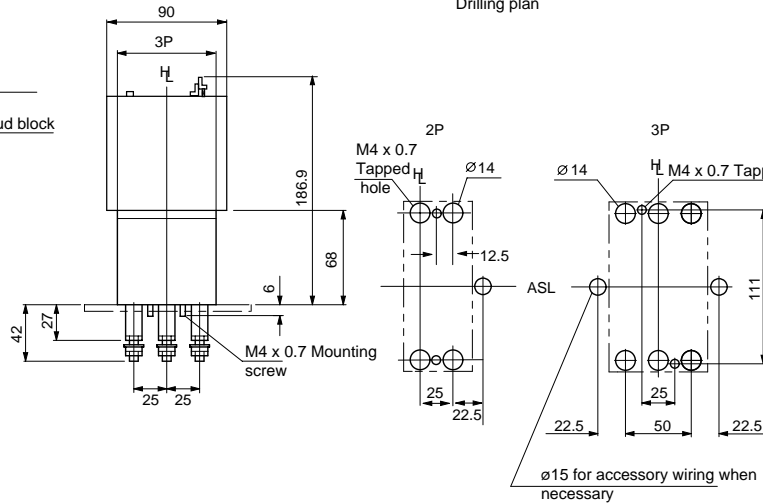

Panel cutout

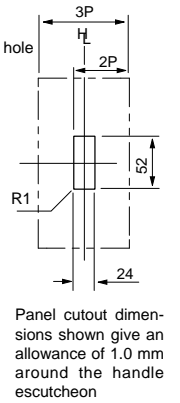

Plug-in

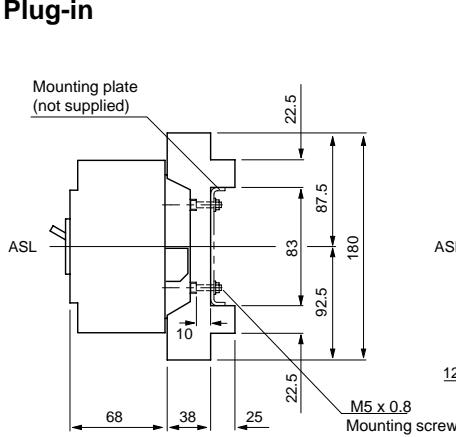

Mounting block

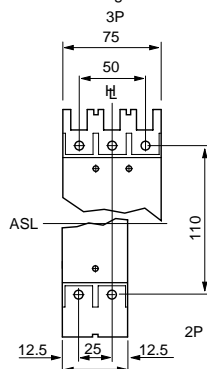

Preparation of conductor

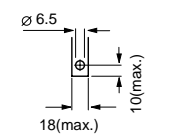

Drilling plan

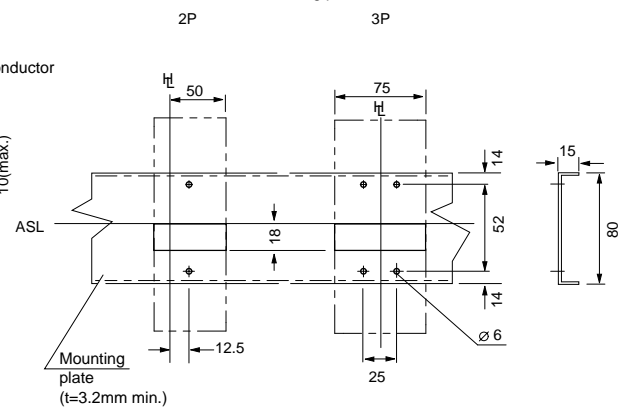

Details for connection

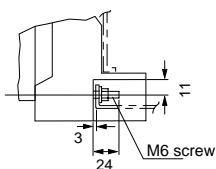

Note: Allow a space of 5mm from adjacent breaker when the breaker is fitted with internal accessories.

7

Outline dimensions (mm)

TemBreak

XE100NS

ASL: Arrangement Standard Line

H_L: Handle Frame Centre Line

Front connected

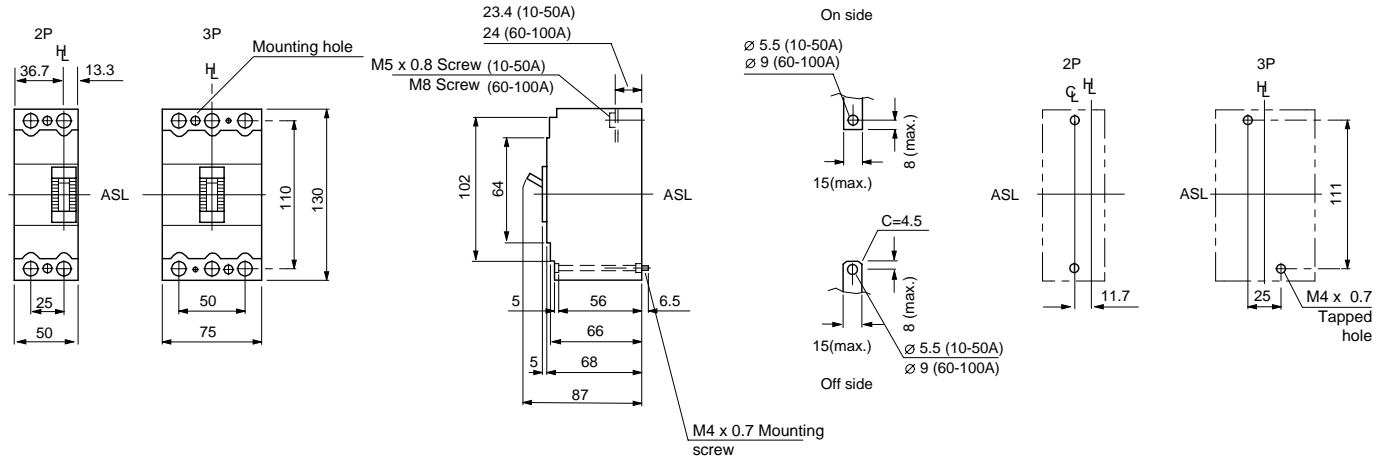

Rear connected with motor operator

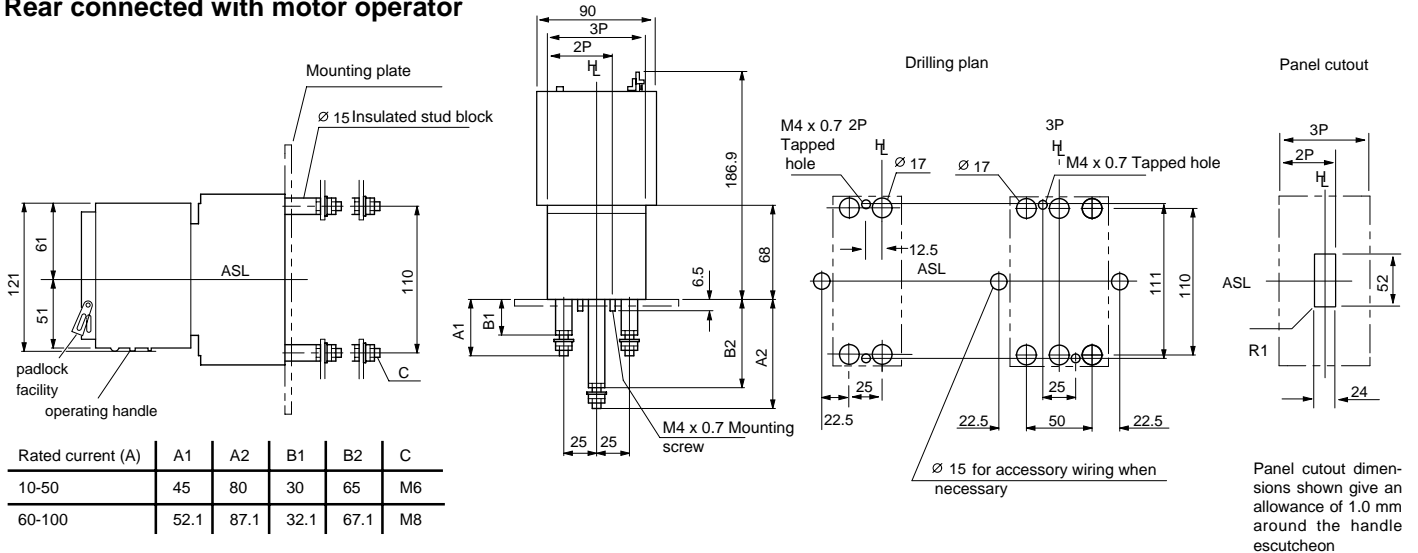

Plug-in

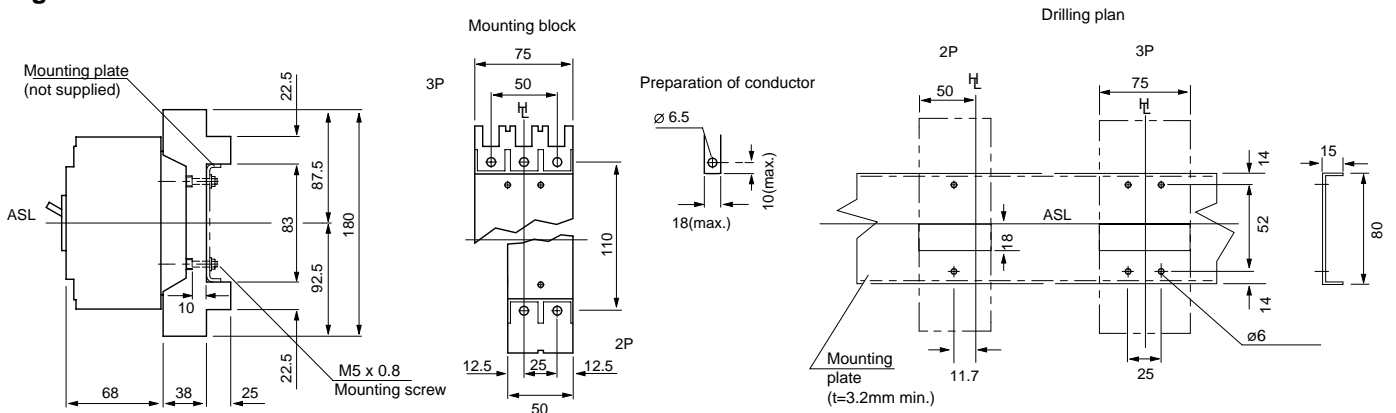

Details of connection

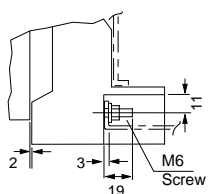

Note: Allow a space of 5mm from adjacent breaker when the breaker is fitted with internal accessories.

7

Outline dimensions (mm)

TemBreak

XS125CS, XS125NS

ASL: Arrangement Standard Line
 H: Handle Frame Centre Line

Front connected

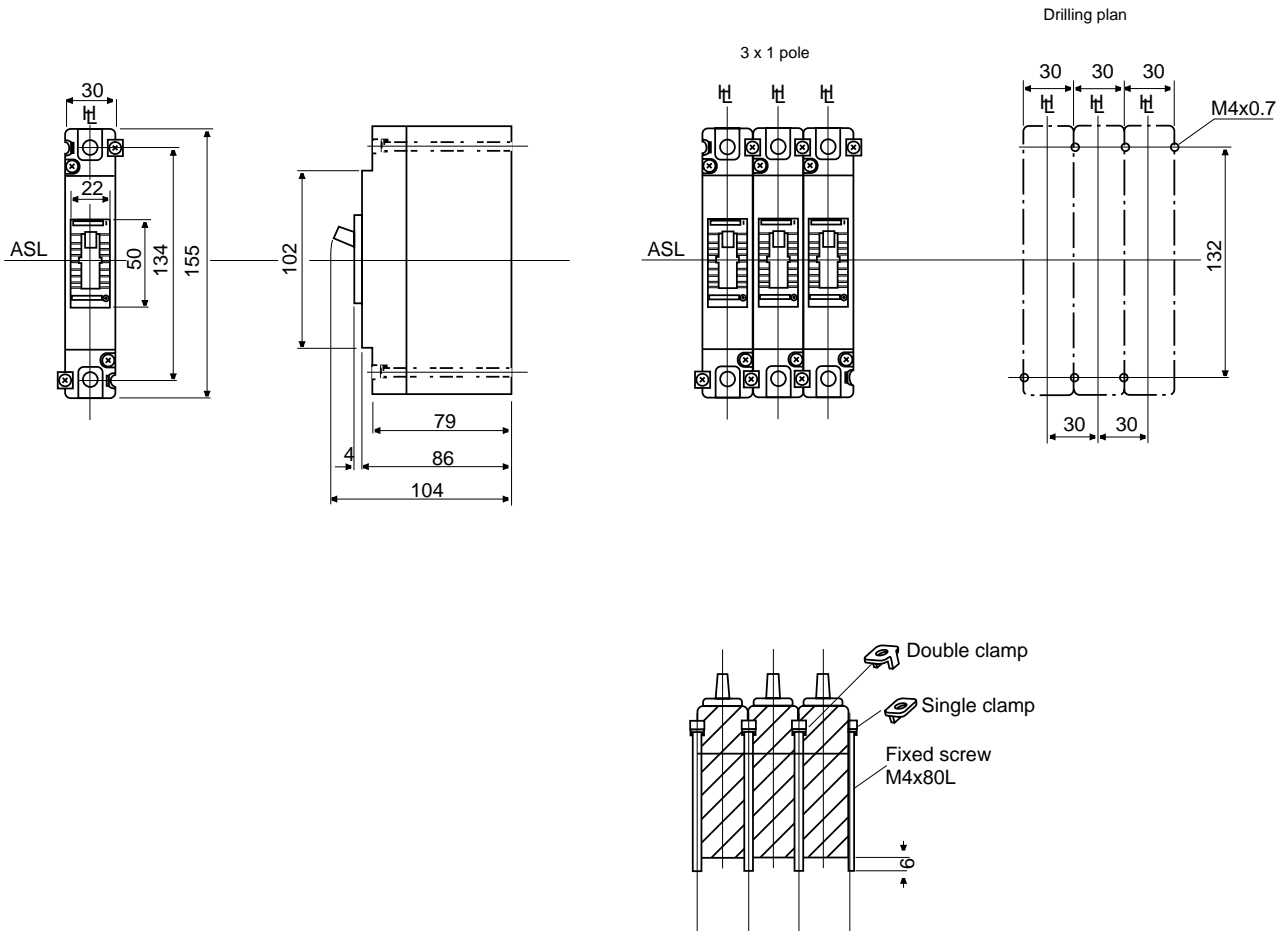

Panel cut-out

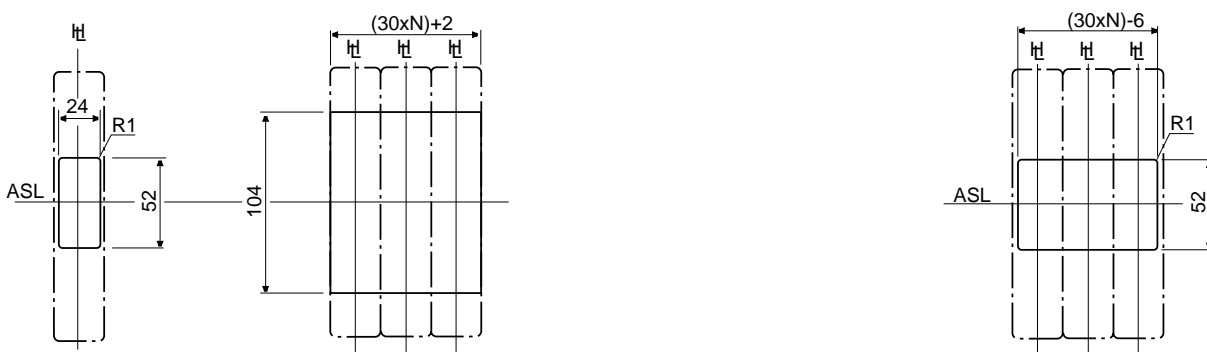



Outline dimensions (mm)

TemBreak

XS125CJ, XS125NJ, XH125NJ, XS125NN

ASL: Arrangement Standard Line
HL: Handle Frame Centre Line

Front connected

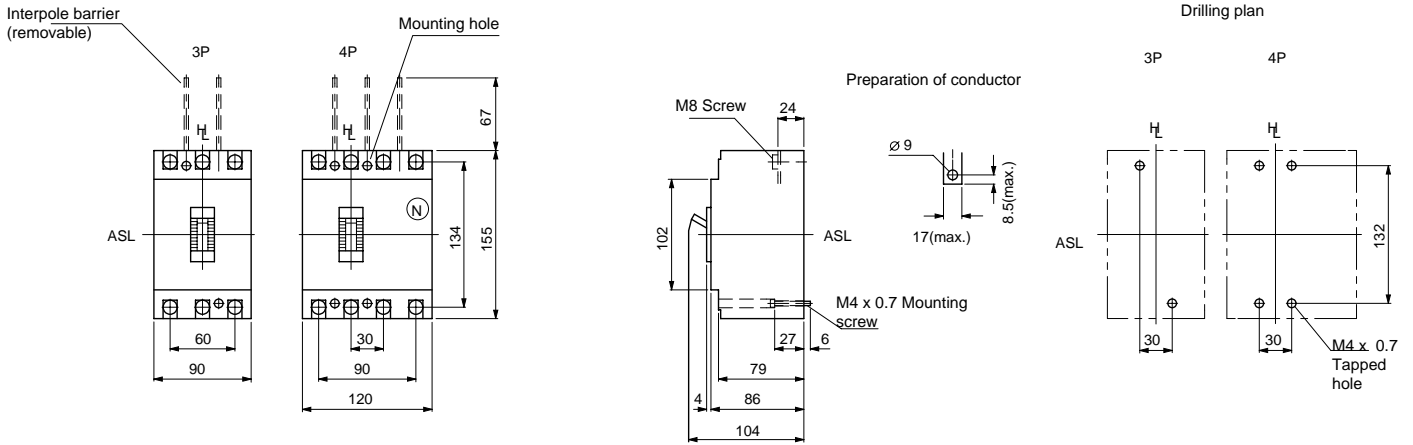

Rear connected with motor operator

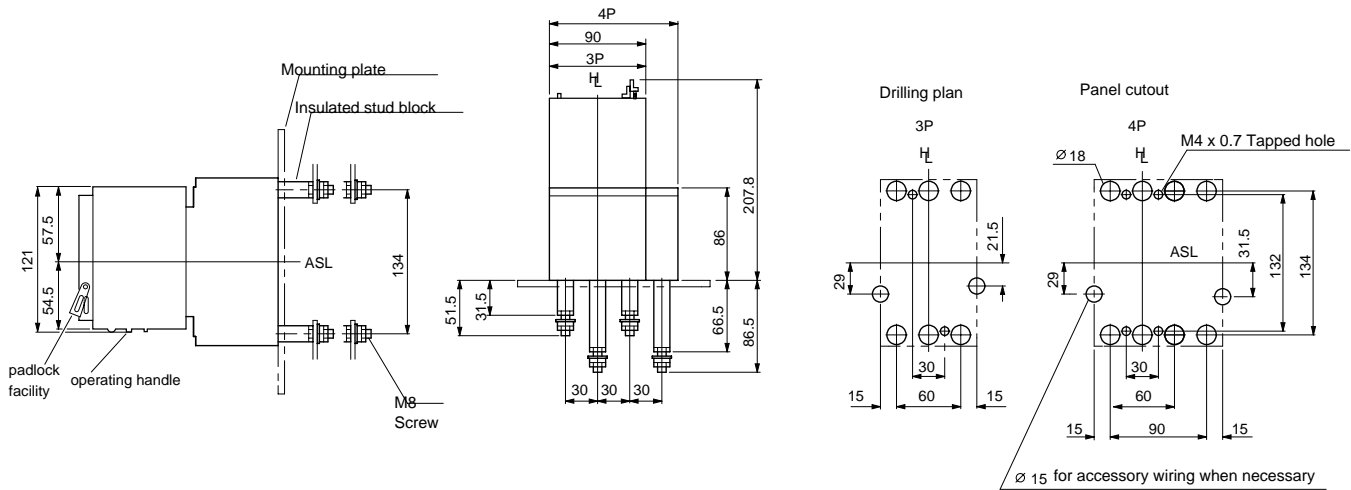

Plug-in

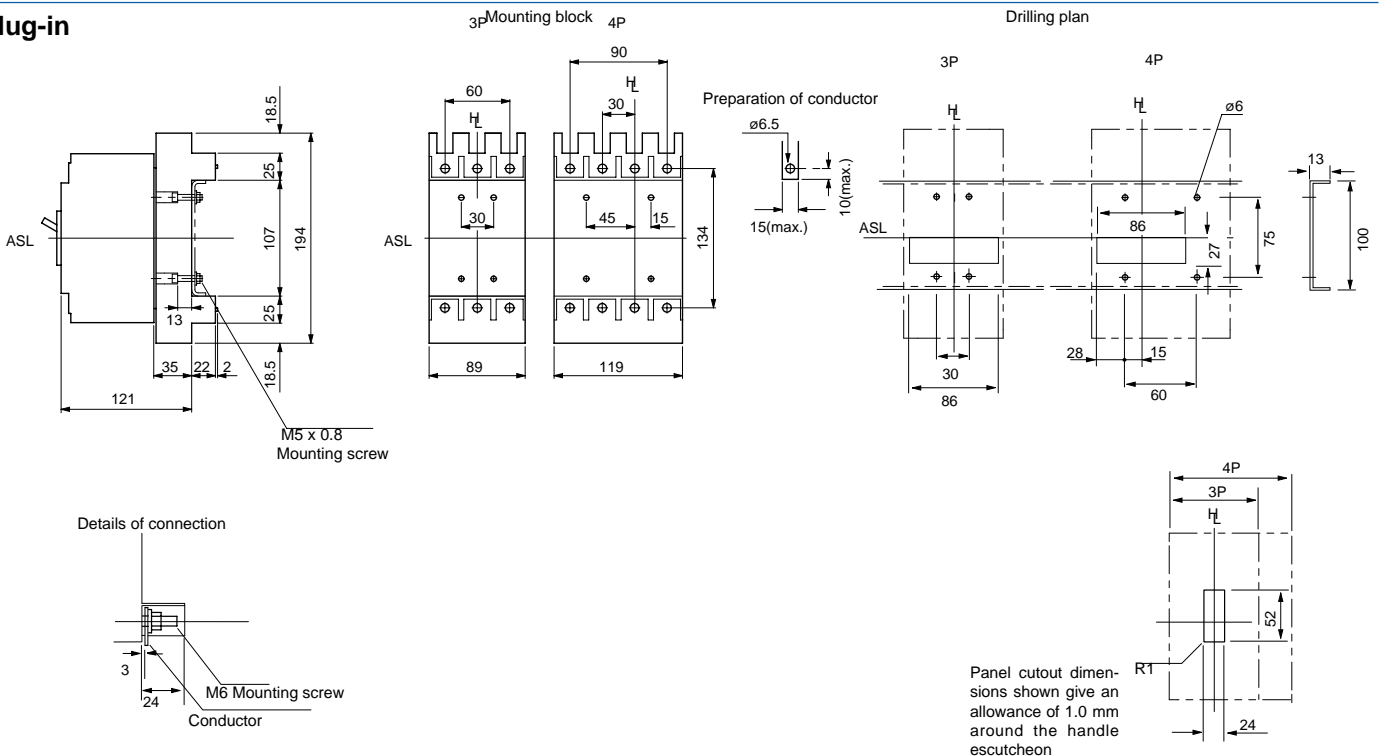



Outline dimensions (mm)

TemBreak

XS160NJ, XS160NN, XE225NS, XS250NJ, XS250NN

Note: XE225NS Available in three pole versions only

ASL: Arrangement Standard Line
H: Handle Frame Centre Line

Front connected

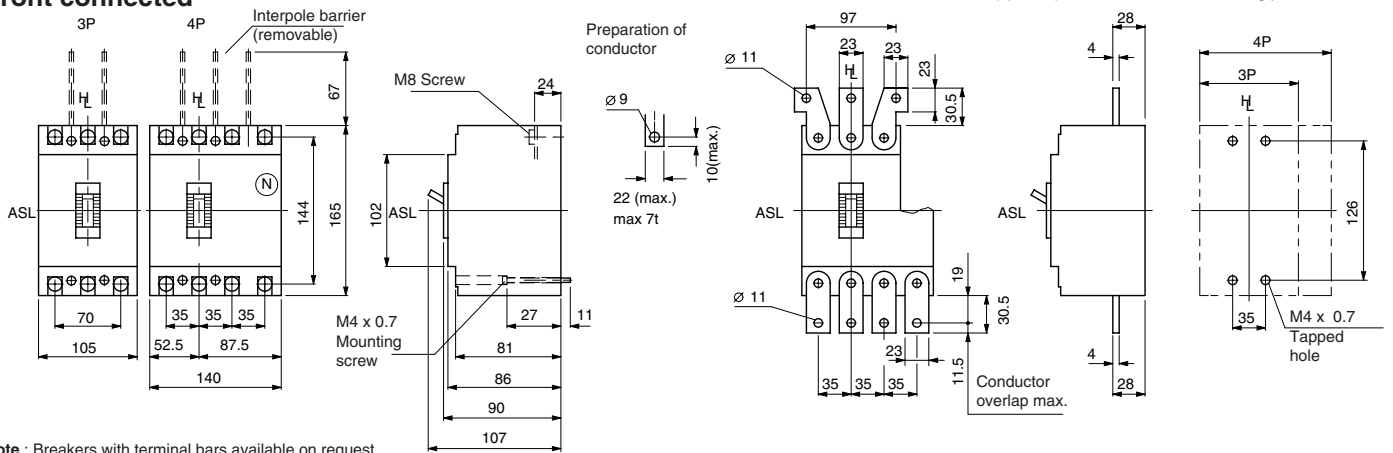

Note: Breakers with terminal bars available on request

Rear connected with motor operator

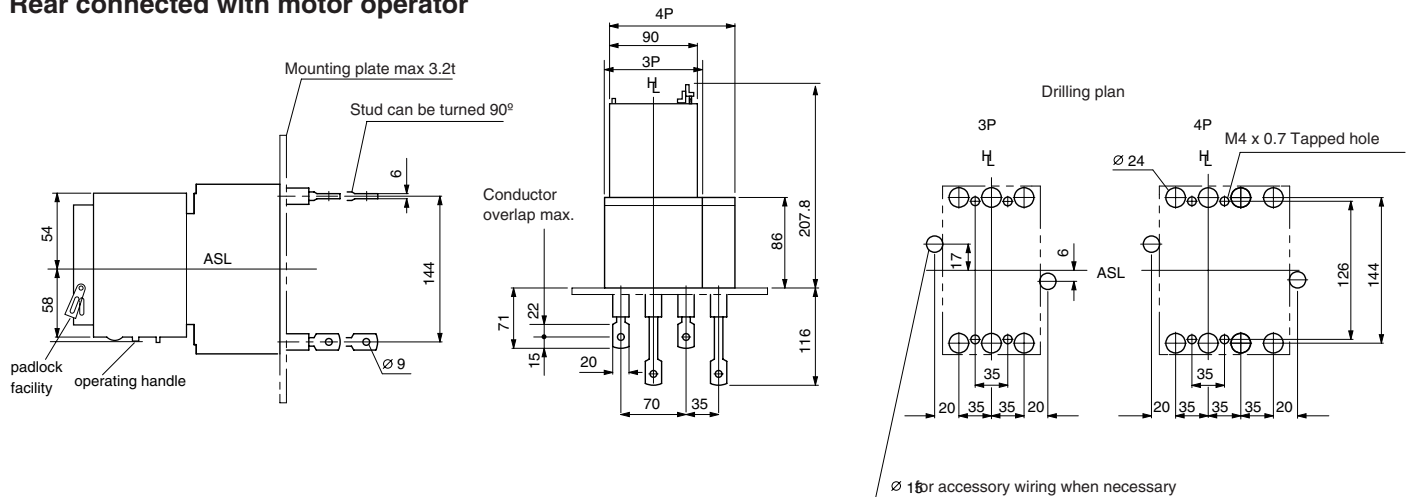

Note: In the normal shipment mode, both terminals on the line and the load side are in the horizontal direction

Plug-in

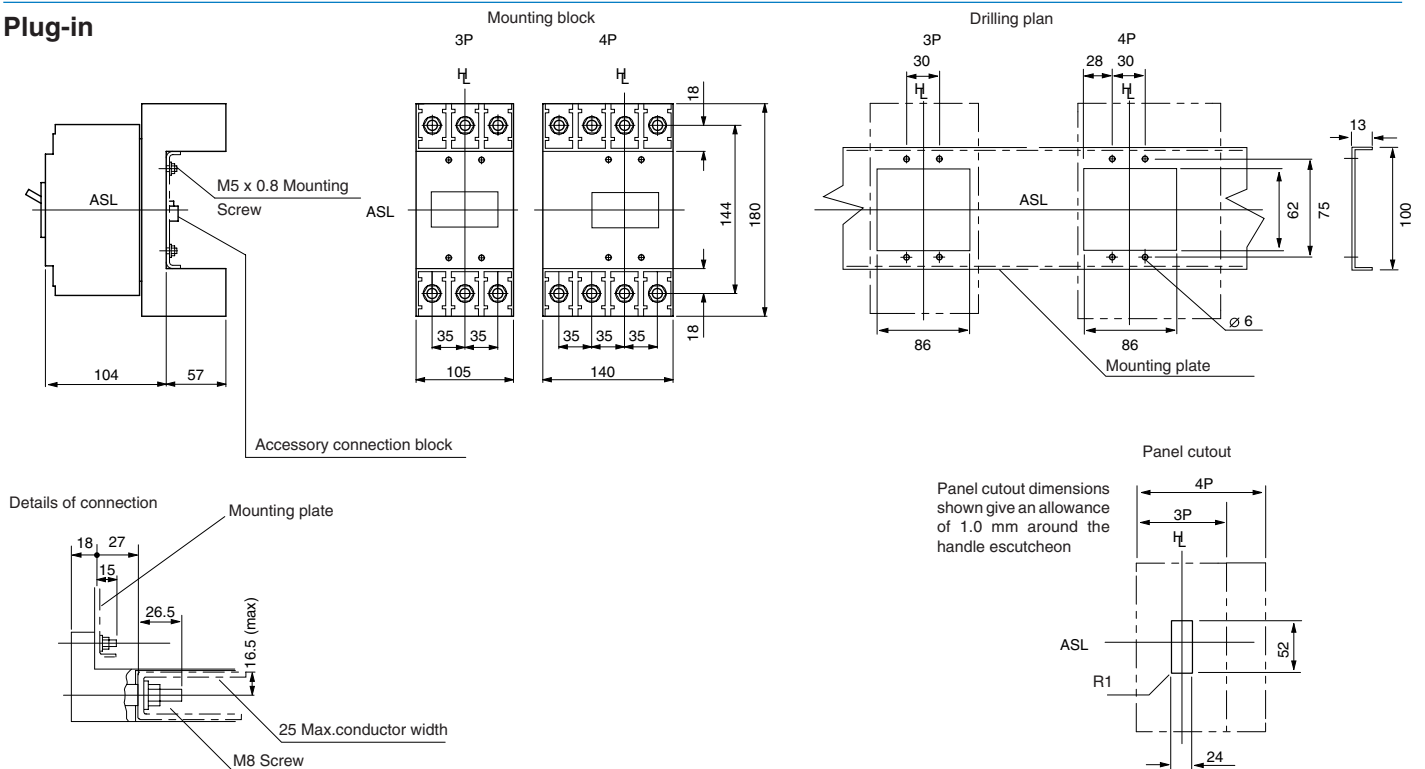



Outline dimensions (mm)

TemBreak

XH160NJ, XS250PJ, XH250NJ

ASL: Arrangement Standard Line
H: Handle Frame Centre Line

Front connected

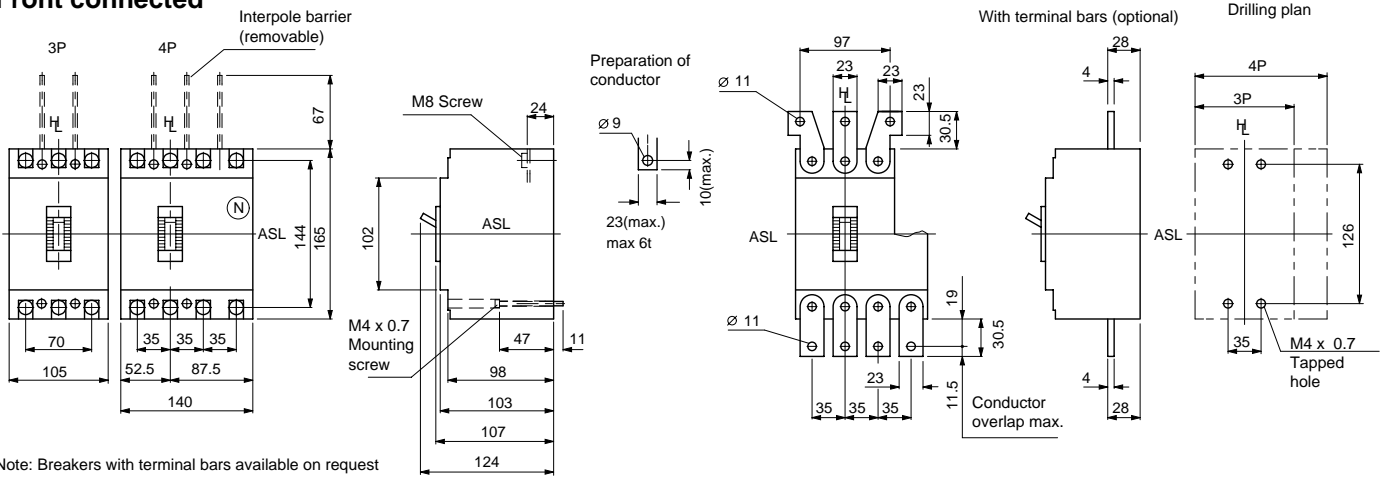

Note: Breakers with terminal bars available on request

Rear connected with motor operator

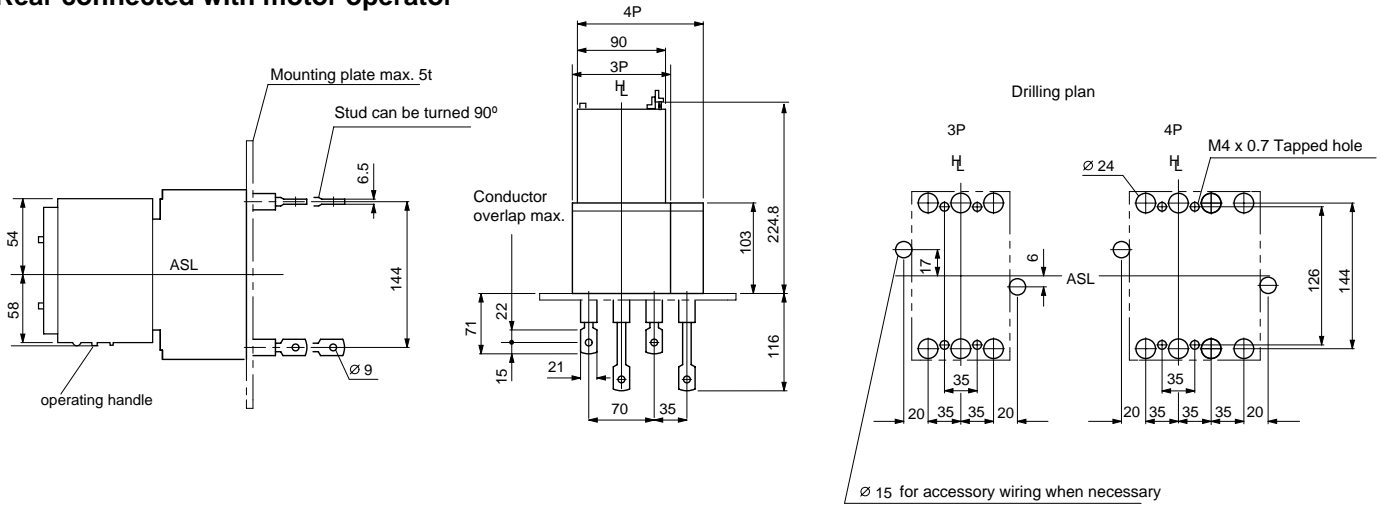

Plug-in

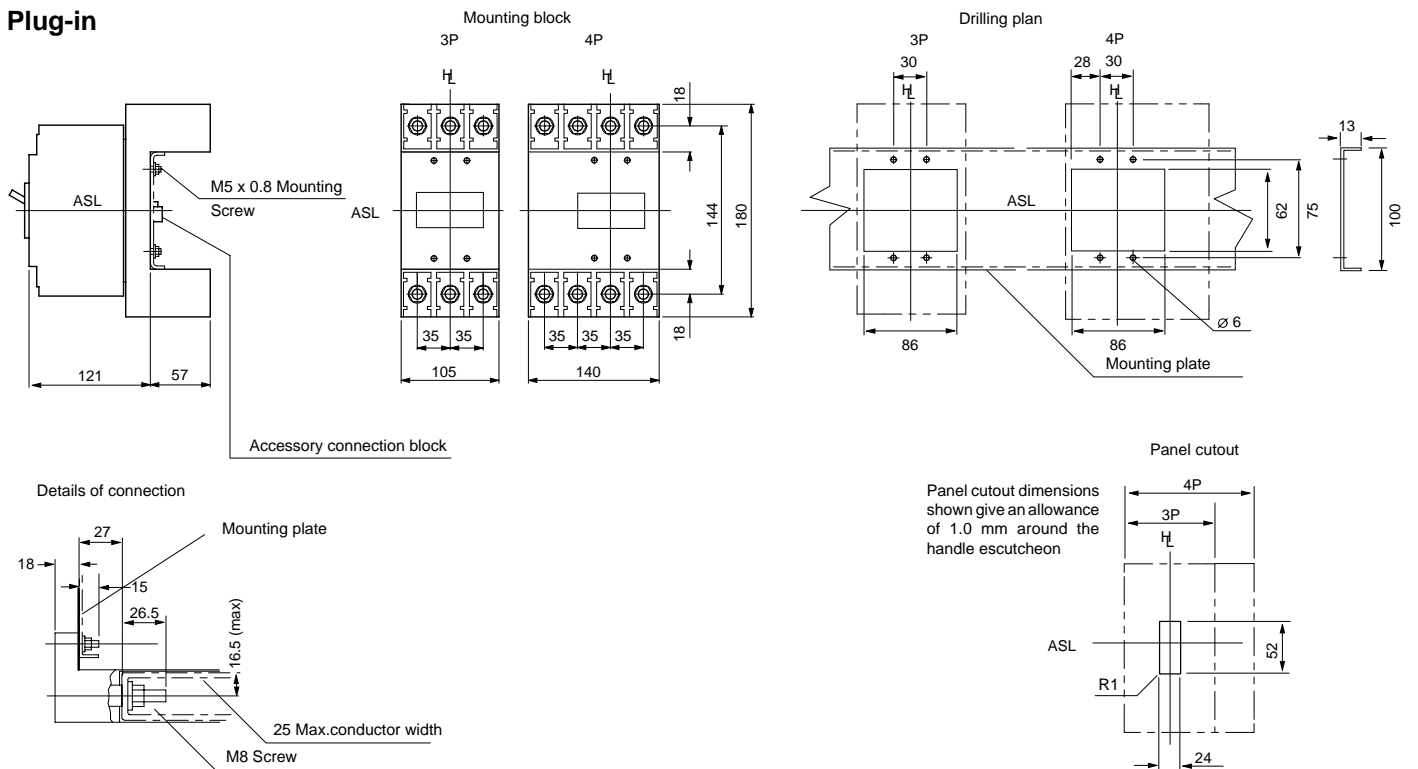



Outline dimensions (mm)

TemBreak

XH250PE, XE400NS, XS400CJ, XS400NJ, XS400SE-C, XS400SE, XH400SE, XS400NN

Note: XE400NS Available in three pole versions only

ASL: Arrangement Standard Line
HL: Handle Frame Centre Line

Front connected

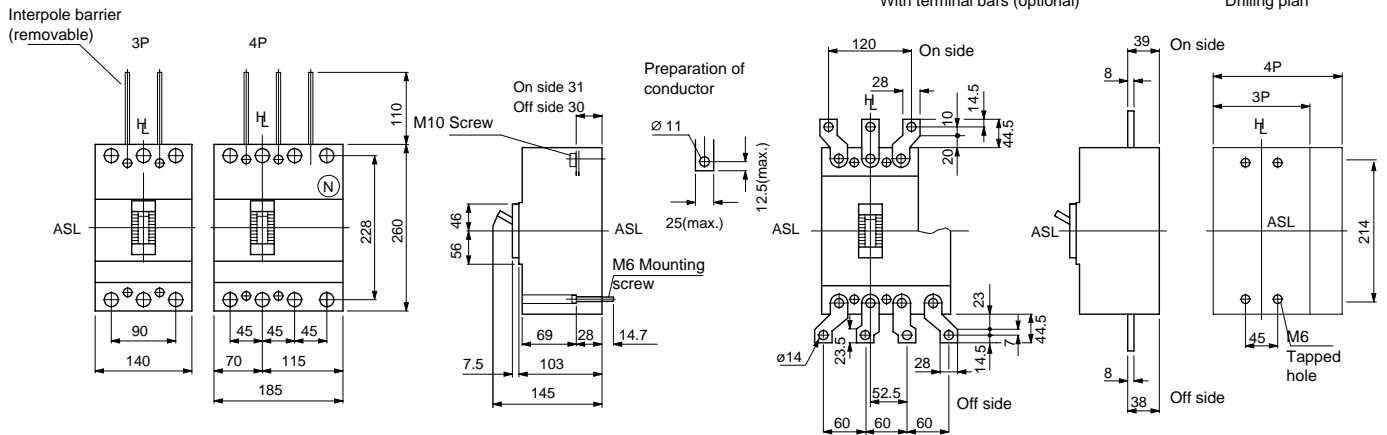

Note: Breakers with terminal bars available on request

Rear connected with motor operator

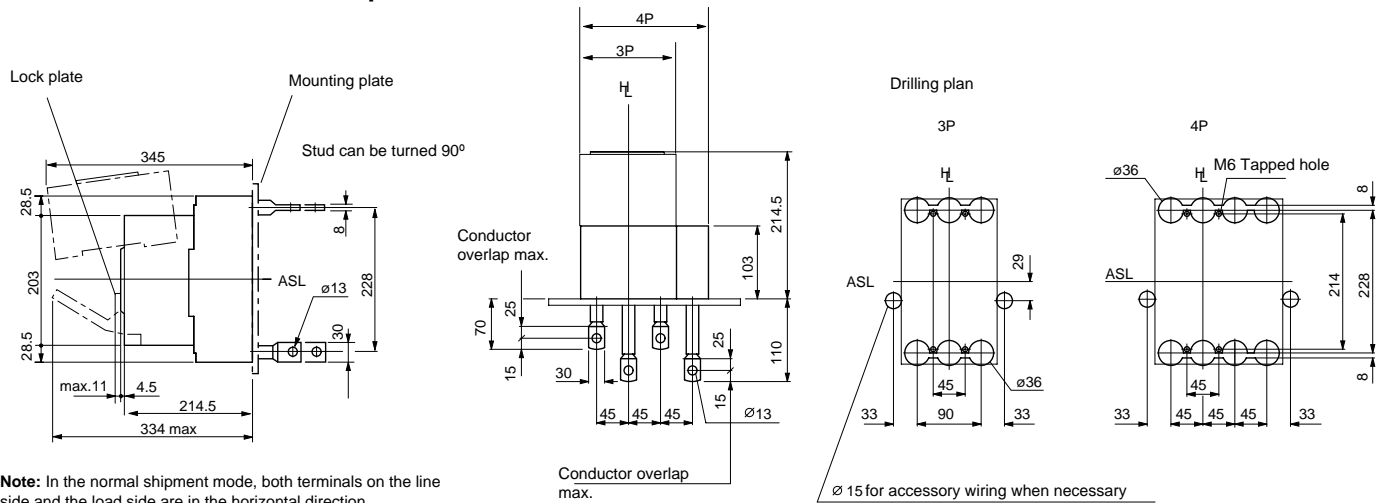

Note: In the normal shipment mode, both terminals on the line side and the load side are in the horizontal direction.

Plug-in

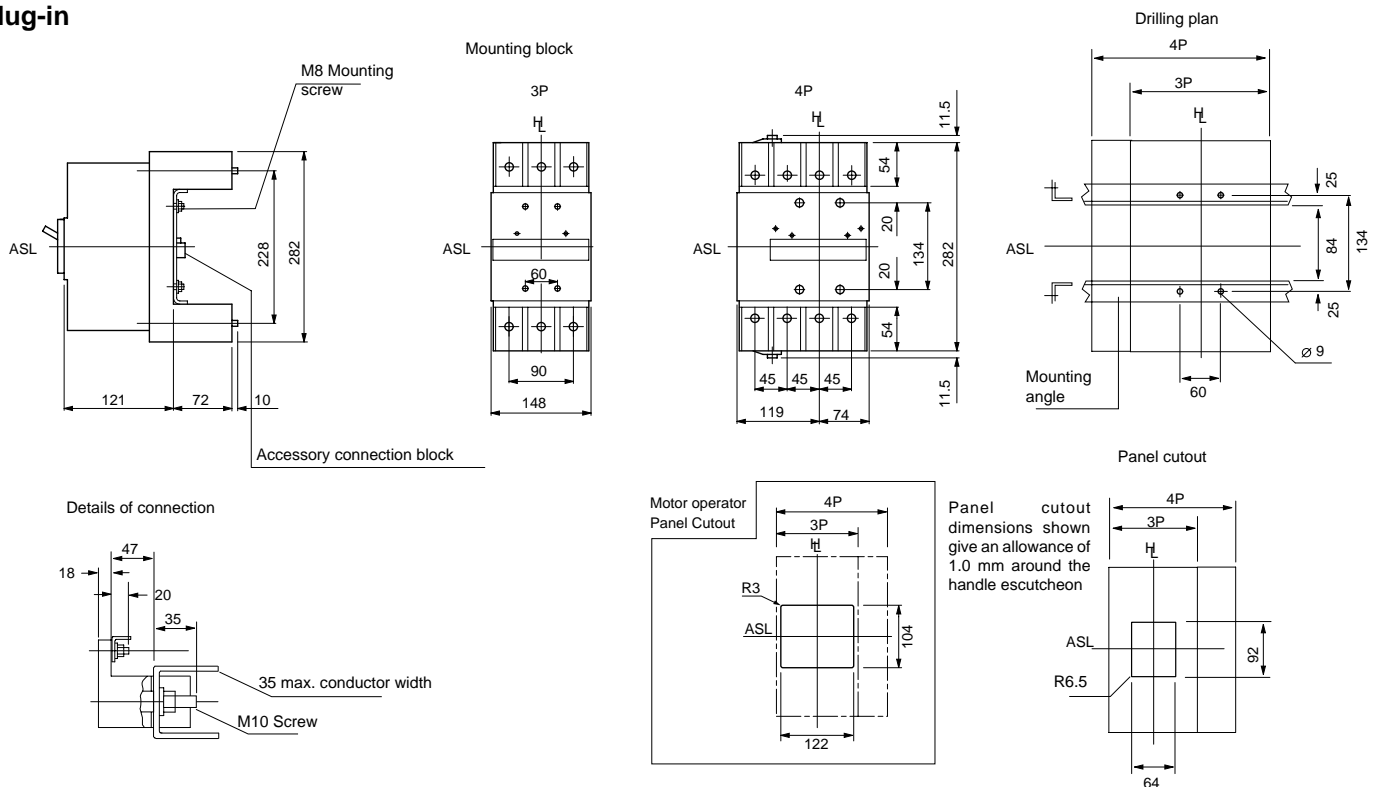



Outline dimensions (mm)

TemBreak

XE600NS, XS630CJ, XS630NJ, XS630SE-C, XS630SE, XH630SE, XS630NN, XS800NJ, XS800SE, XH800PS, XH800SE, XS800NN, XS1000ND

Note: XE600NS & XS1000ND Available in three pole versions only

ASL: Arrangement Standard Line
HL: Handle Frame Centre Line

Front connected

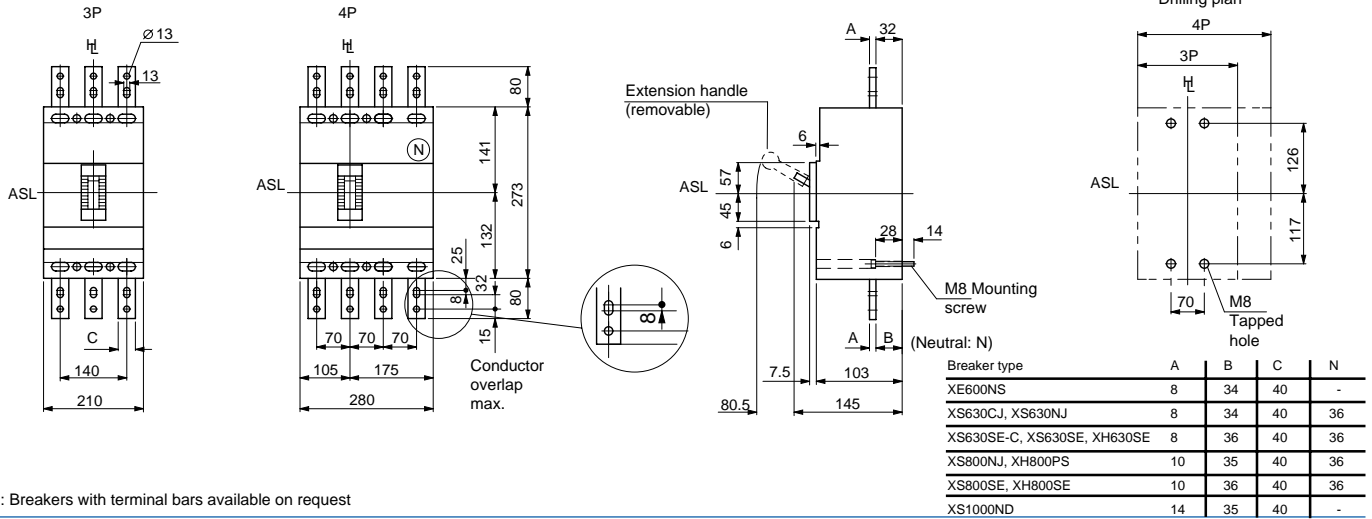

Note: Breakers with terminal bars available on request

Rear connected with motor operator

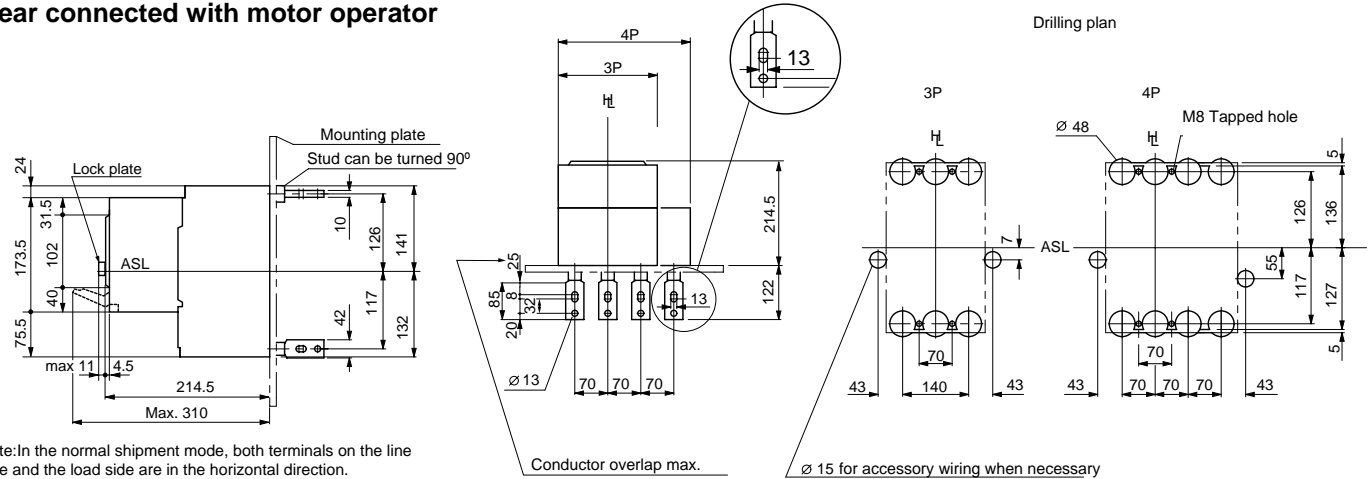

Plug-in

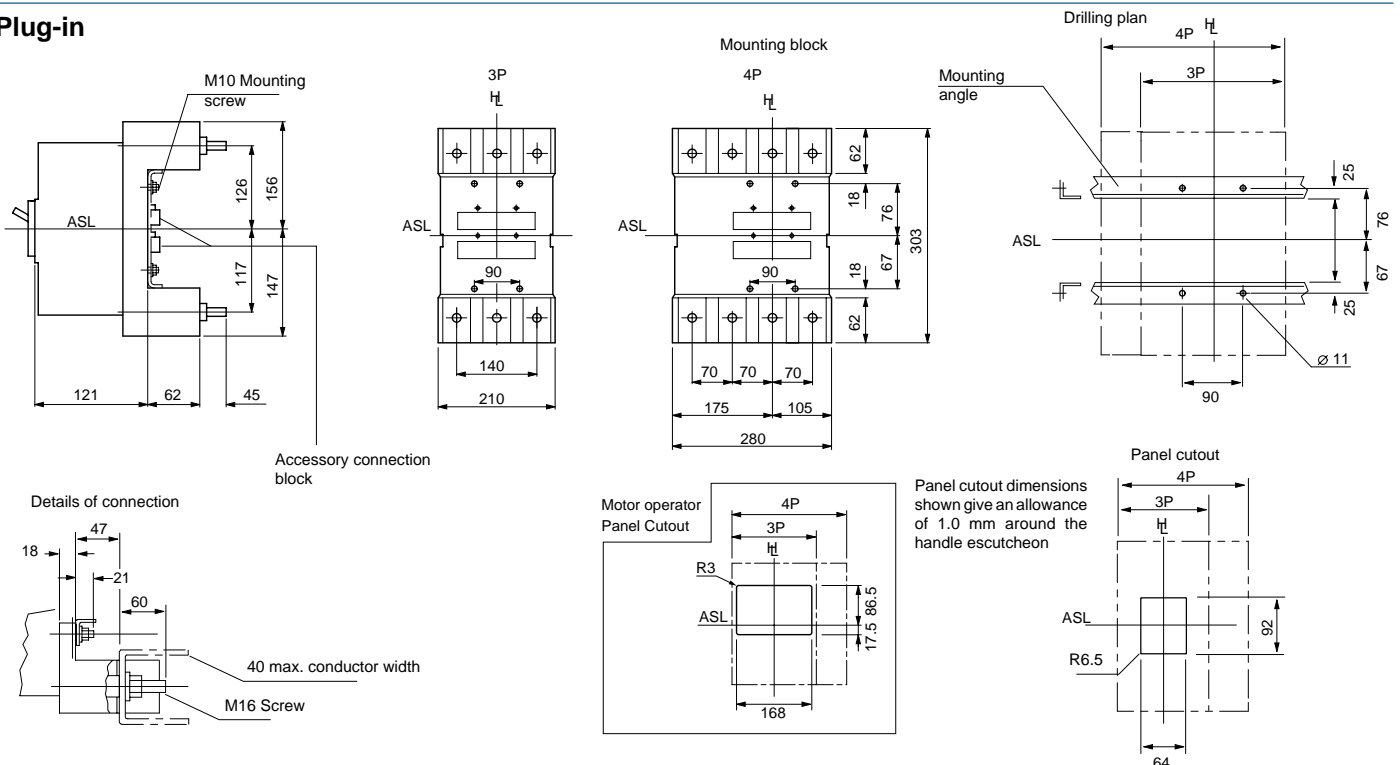



Outline dimensions (mm)

TemBreak

XS1250SE, XS1250NN

ASL: Arrangement Standard Line
HL: Handle Frame Centre Line

Front connected

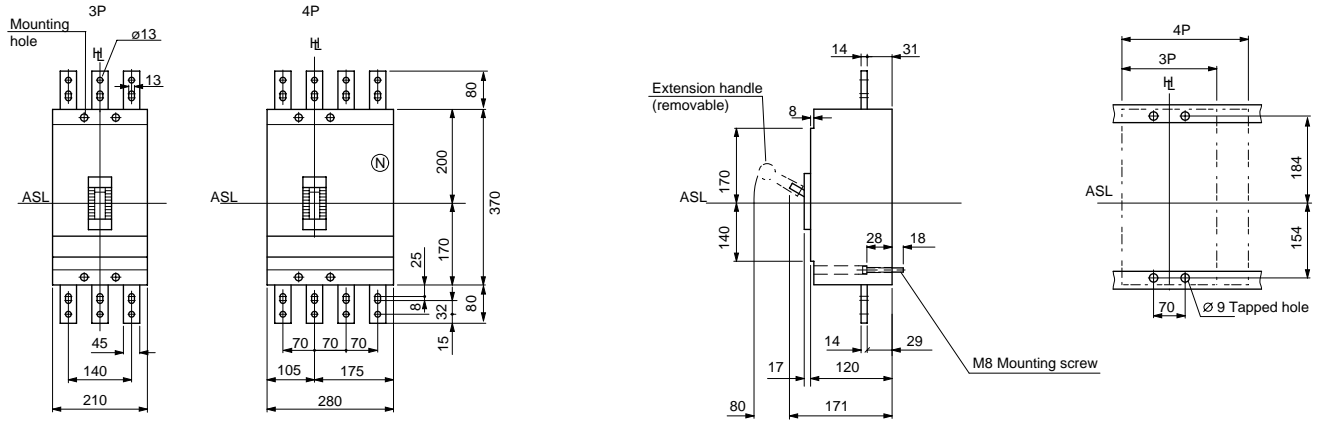

Rear connected with motor operator

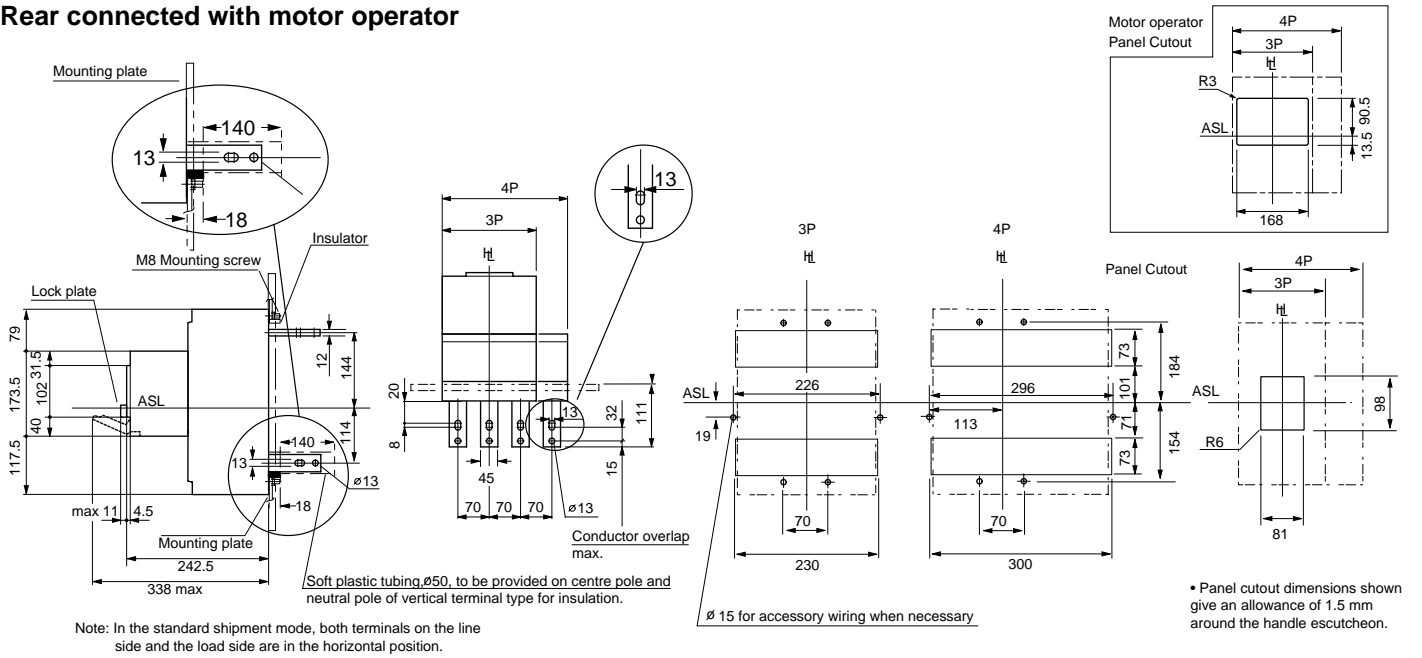

Plug-in

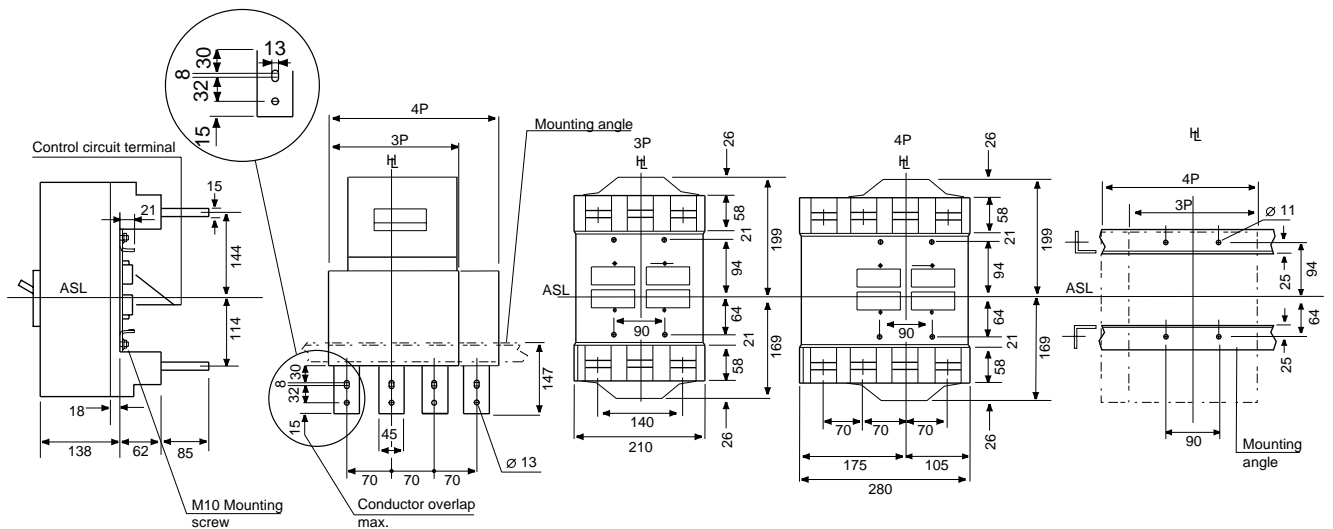

Front connected

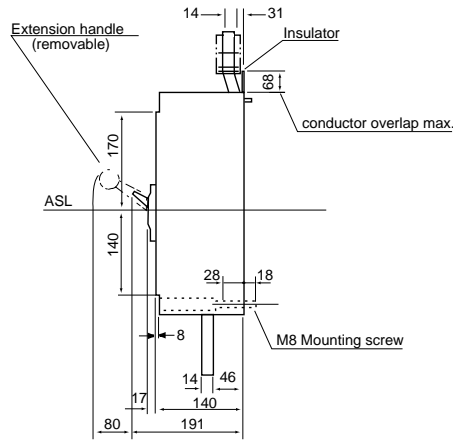
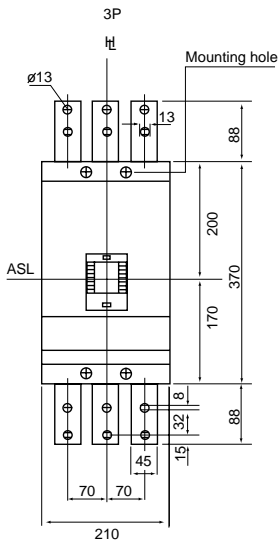

Drilling plan

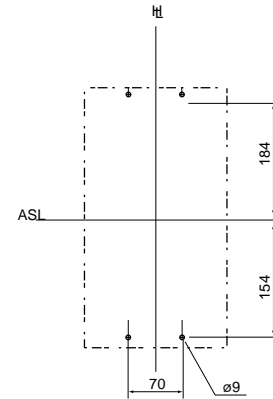

Rear connected

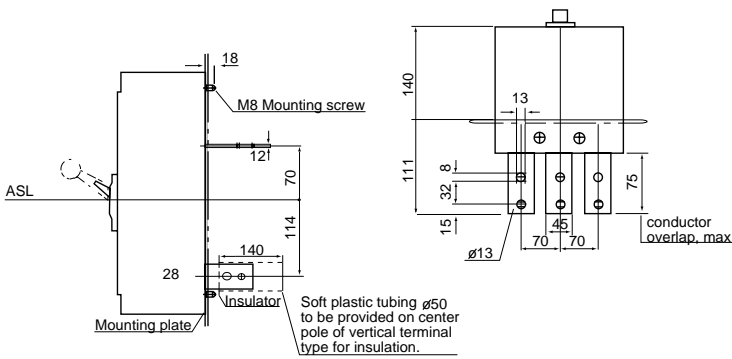

Drilling plan

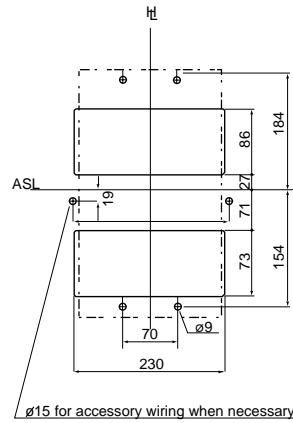

Panel cutout (*)

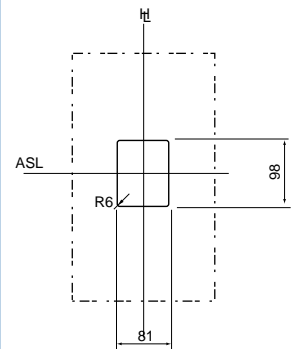

Note: In the standard shipment mode, both terminals on the line side and the load side are in horizontal direction.
For the vertical arrangement, specify it when ordering.

*Panel cut-out dimensions shown give an allowance of 1.5mm around the handle escutcheon.



Outline dimensions (mm)

TemBreak

XS1600SE, XS1600NN, XS1600ND

Note: XS1600ND available in 3 pole only

ASL : Arrangement Standard Line
Ht : Handle Frame Centre Line

Front connected

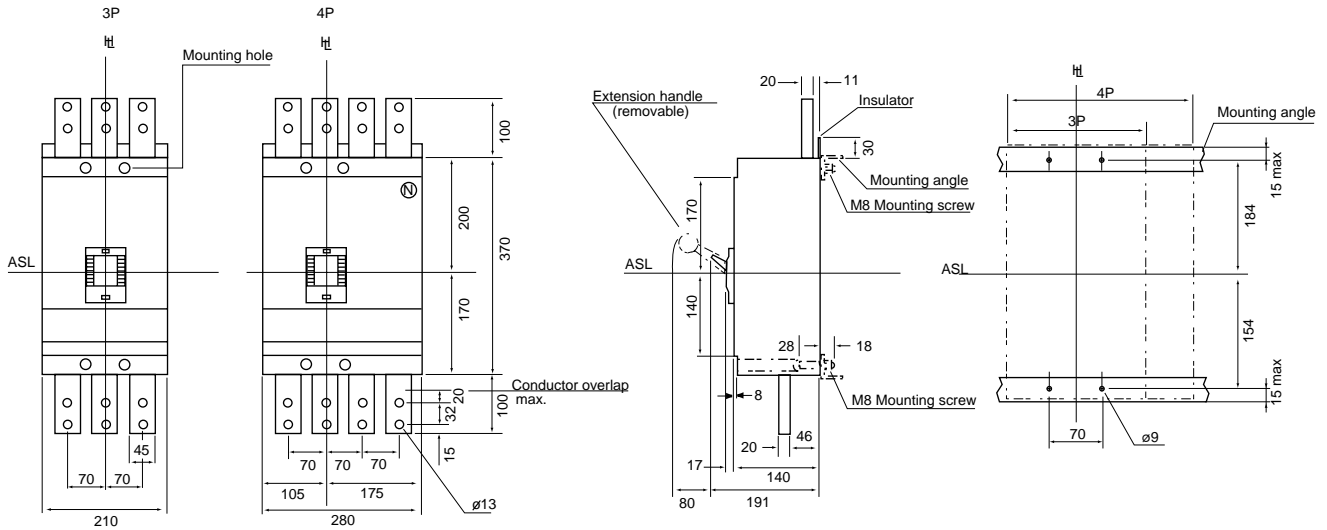

Rear connected with motor operator

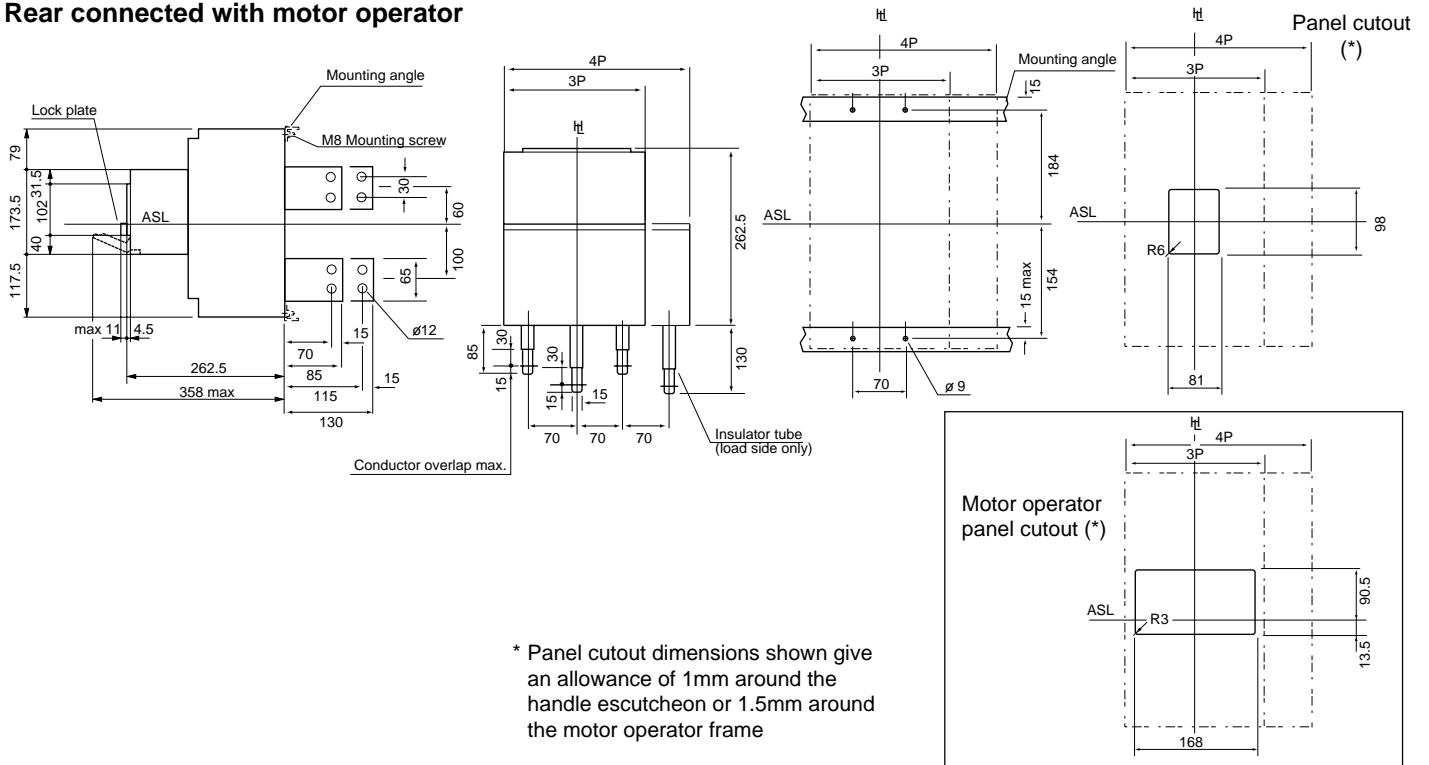

Draw-out

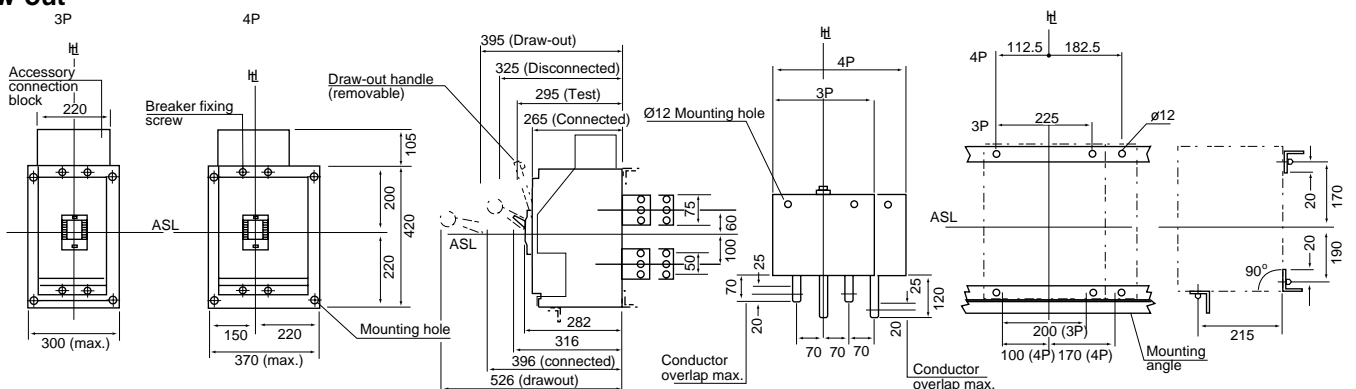



Outline dimensions (mm)

TemBreak

XS2000NE, XS2000ND

Note: XS2000ND available in 3 pole only

ASL: Arrangement Standard Line
H_L: Handle Frame Centre Line

Front connected

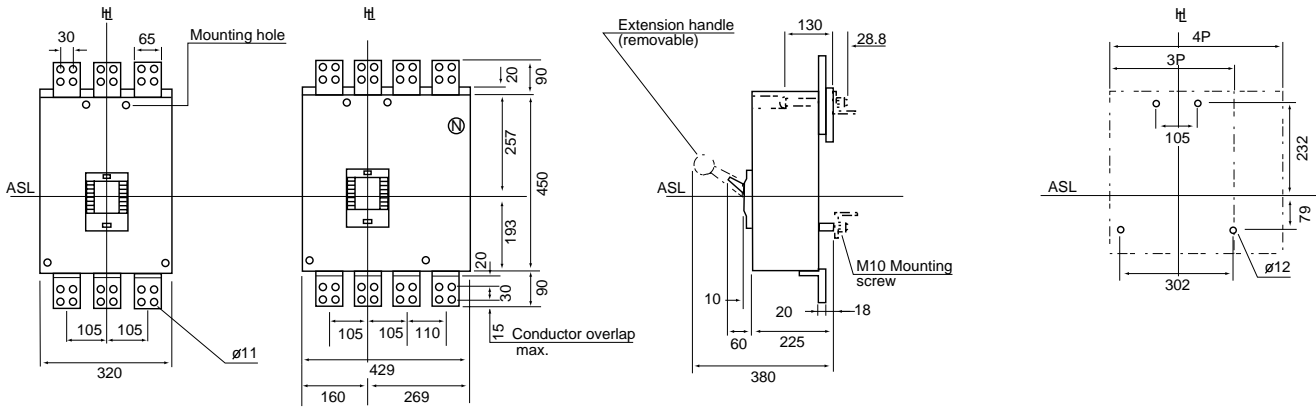

Rear connected with motor operator

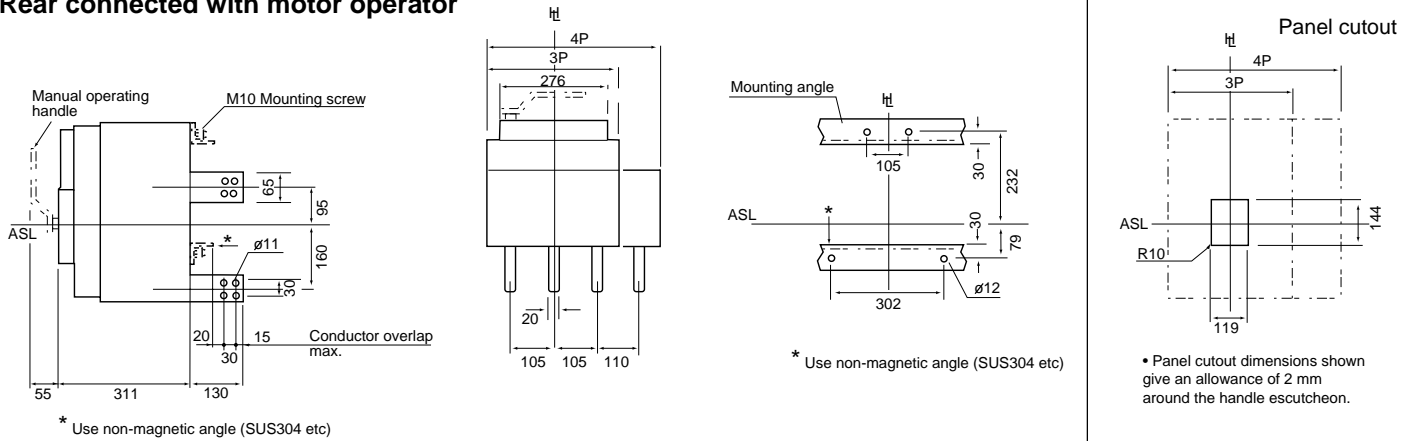

Draw-out

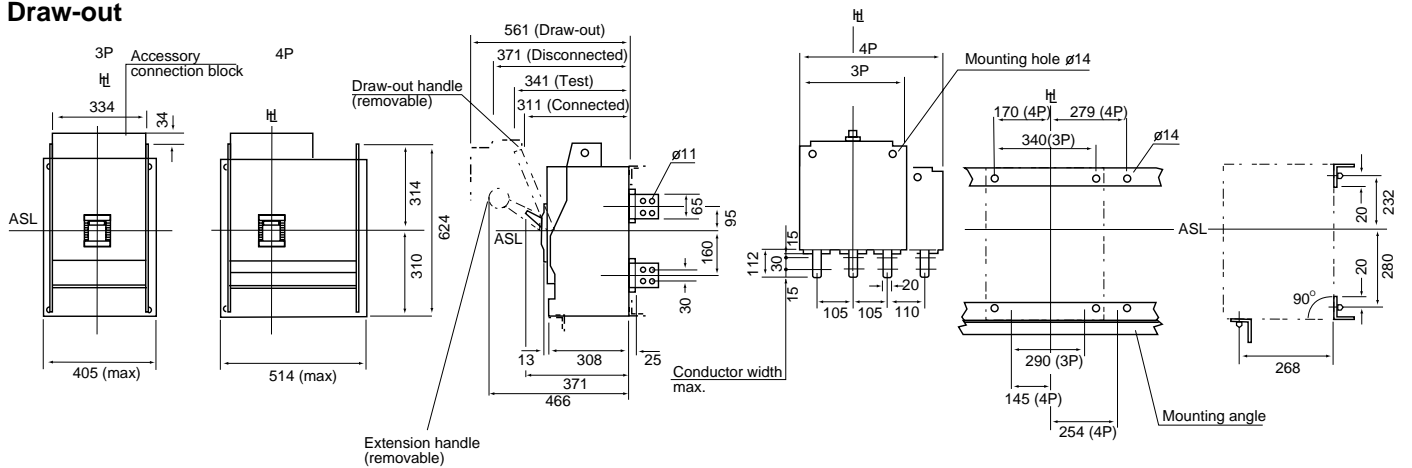



Outline dimensions (mm)

TemBreak

XS2500NE, XS2500ND

Note: XS2500ND available in 3 pole only

ASL: Arrangement Standard Line
HL: Handle Frame Centre Line

Rear connected

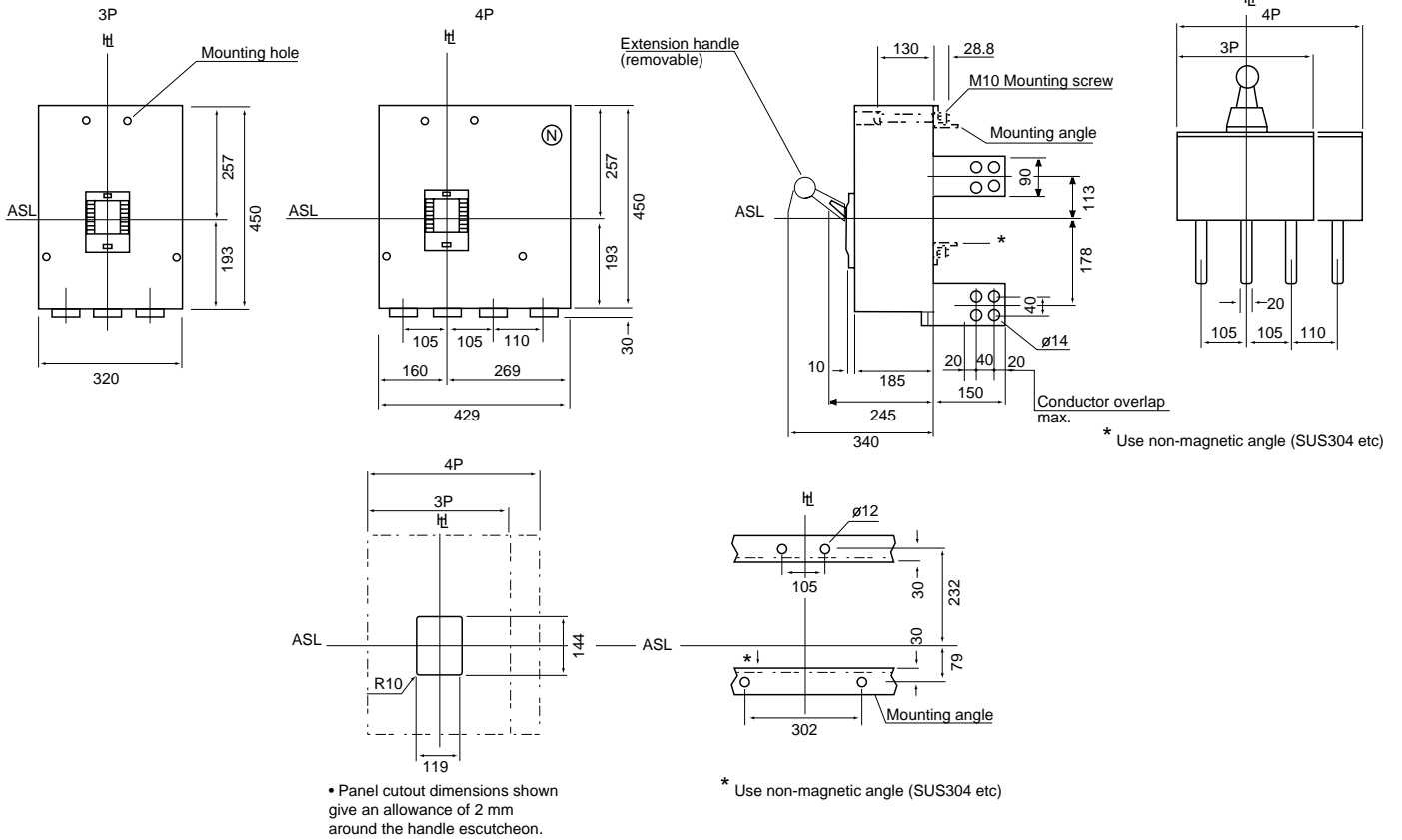

Rear connected with motor operator

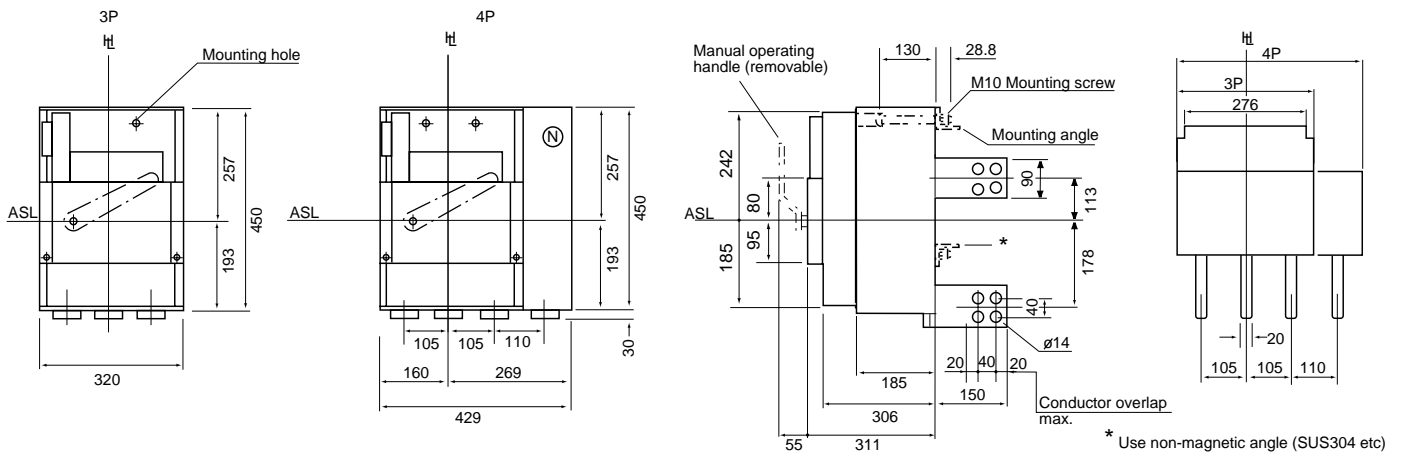

Catalogue Item Numbers

119-153

• Examples	120
• XM30PB	121-122
• XS50NB	123-124
• XE100NS	125-126
• XS125CS, XS125NS	127
• XS125CJ, XS125NJ, XH125NJ, XS125NN	128-130
• XS160NJ, XS160NN, XS250NJ, XS250NN	131-132
• XE225NS	
• XH160NJ, XH250NJ, XS250PJ	133-134
• XE400NS, XS400CJ, XS400NJ, XS400NN	135-137
• XH250PE, XS400SE-C, XS400SE, XH400SE	
• XE600NS, XS630CJ, XS630NJ, XS630NN	138-141
• XS630SE-C, XS630SE, XH630SE	
• XS800NJ, XS800NN, XH800PS, XS800SE, XH800SE	142-145
• XS1250NN, XS1000ND, XS1250ND, XS1250SE, XS1600NN, XS1600ND, XS1600SE	146-149
• XS2000ND, XS2000NE, XS2500ND, XS2500NE	150-151
• Earth Leakage Relays	152
• TemMeasure Multimeters and Analysers	152
• Earth Leakage Blocks	153
• TemTransfer Automatic Changeover Controller	153

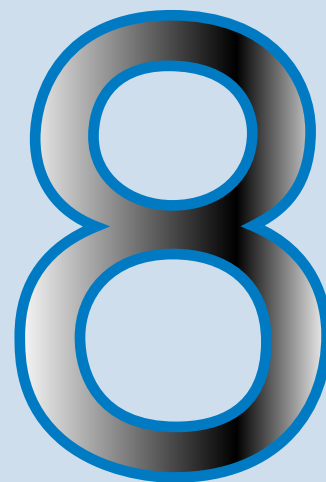

The following examples show which item numbers are used to build common combinations of MCCBs and accessories.

Example 1: XS400NJ, 3 pole, plug in type, fitted with undervoltage trip and OHH operating handle Refer to item numbers on pages 127-129.

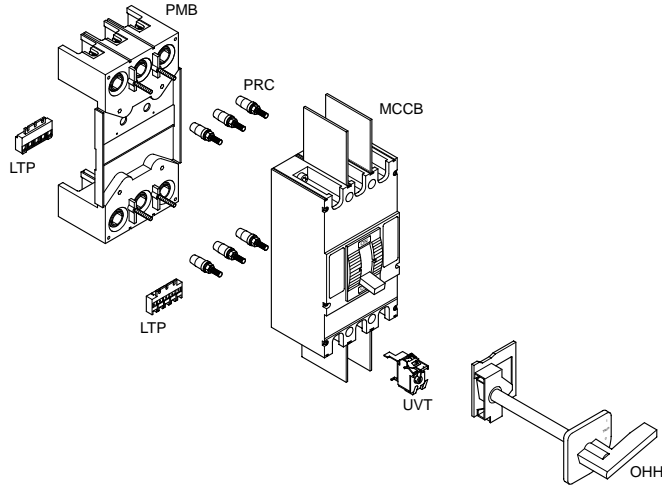

Select MCCB
 Select UVT operating voltage and time delay
 Select plug in connections (standard or IP20)
 Select plug in auxiliary connections for the MCCB (these are only required when electrical accessories are fitted to a plug in breaker. 1 terminal is required for each control wire, each connector has either 3 or 5 terminals)
 Select handle operating direction (C/W - clockwise or AC.W - anti-clockwise)
 Select door opening position (reset or off) and shaft length (std - standard or LNG - long)
 Select plug in base (standard or IP20)
 Select plug in auxiliary connections for the base (these are only required when electrical accessories are fitted to a plug in breaker. 1 terminal is required for each control wire, each connector has either 3 or 5 terminals).

XS400NJ 400A 3P FC MCCB	204320540
UVT AC 200 - 240V	211002074
PLUG IN CONNECTIONS	211003056
5 MCCB SIDE PLUG IN AUX CONN	215003072
OHH C/W RESET OPEN STD	212005005
PLUG IN BASE	211007037
5 BASE SIDE PLUG IN AUX CONN	215007049

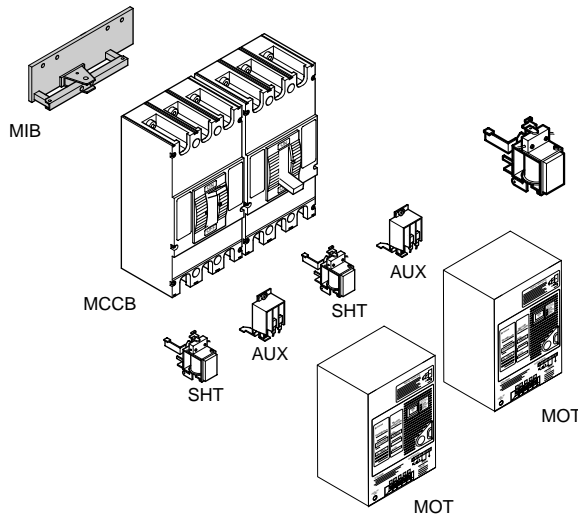

Select MCCB
 Select combination of alarm/auxiliary contacts
 Select shunt trip voltage
 Select motor operator voltage
 Select type of mechanical interlock. In this case, rear or wire mechanical interlock must be used as front mechanical interlock cannot be fitted with motor operators. The option including accessories must be selected to ensure that a terminal block for the auxiliary switch and shunt trip wiring is included. One mechanical interlock part per MCCB must be included.

XS630CJ 630A 3P FC MCCB	2 off 205410563
1AB AUXILIARY SWITCH	2 off 215001005
SHUNT DC 24V	2 off 215002032
MOTOR AC 240V	2 off 215008043
REAR MECH INTLTK + ACC	2 off 215009060



Moulded Case Circuit Breakers

Item No	Description	Item No	Description
204180500	XM30PB/0.7A 3P FC MCCB		
204180501	XM30PB/1.4A 3P FC MCCB		
204180510	XM30PB/10A 3P FC MCCB		
204180512	XM30PB/12A 3P FC MCCB		
204180503	XM30PB/2.6A 3P FC MCCB		
204180502	XM30PB/2A 3P FC MCCB		
204180504	XM30PB/4A 3P FC MCCB		
204180505	XM30PB/5A 3P FC MCCB		
204180508	XM30PB/8A 3P FC MCCB		
204180301	XM30PB/1.4A 3P PLUG IN MCCB		
204180310	XM30PB/10A 3P PLUG IN MCCB		
204180312	XM30PB/12A 3P PLUG IN MCCB		
204180303	XM30PB/2.6A 3P PLUG IN MCCB		
204180302	XM30PB/2A 3P PLUG IN MCCB		
204180304	XM30PB/4A 3P PLUG IN MCCB		
204180305	XM30PB/5A 3P PLUG IN MCCB		
204180308	XM30PB/8A 3P PLUG IN MCCB		

Auxiliary Switches



211001080	1AB AUXILIARY SWITCH
211001081	2AB AUXILIARY SWITCH
211001083	ALARM SWITCH
211001088	1AB AUX ALARM SWITCH

Shunt Trips



211002262	SHUNT AC 100-115V
211002263	SHUNT AC 200-480V
211002265	SHUNT DC 24V
211002266	SHUNT DC 48V
211002267	SHUNT DC 100-115V
211002278	SHUNT AC 24V
211002279	SHUNT AC 48V
211002264	SHUNT DC 12V
211002323	SHUNT DC30V
211002280	SHUNT DC 60V
211002324	SHUNT DC125V
211002268	SHUNT DC 200-230V

Connections

211003326	REAR CONNECTIONS
-----------	------------------

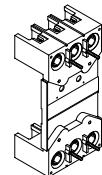

Plug-In Bases

211007145	PLUG-IN BASE
-----------	--------------

Mechanical Interlocks

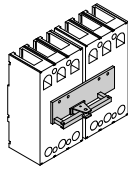

Item No	Description
211009090	FRONT MECHANICAL INTERLOCK
211011010	HANDLE HOLDER
211011009	HANDLE HOLDER & LOCK
211005159	DOOR FLANGE

Handle Mechanisms

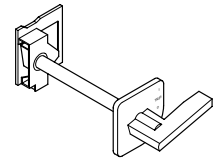

Item No	Description	OHH
211005339	OHE:HANDLE OPER MECHNSM.	
211005358	OHJ:RIGHT:BLACK:HANDLE	
211005359	OHJ:RIGHT:BLACK:IP55 HANDLE	
211005360	OHJ:RIGHT:RED/YEL:HANDLE	
211005361	OHJ:RIGHT:RED/YEL:IP55 HANDLE	
211005362	OHJ:LEFT:BLACK:HANDLE	
211005363	OHJ:LEFT:BLACK:IP55 HANDLE	
211005364	OHJ:LEFT:RED/YEL:HANDLE	
211005365	OHJ:LEFT:RED/YEL:IP55 HANDLE	
211005366	OHJ:UPPER:BLACK:HANDLE	
211005367	OHJ:UPPER:BLACK:IP55 HANDLE	
211005368	OHJ:UPPER:RED/YEL:HANDLE	
211005369	OHJ:UPPER:RED/YEL:IP55 HANDLE	
211005325	OHH CW OFF OPEN LONG	
211005321	OHH C/W OFF OPEN STD	
211005323	OHH CW RESET OPEN LG	
211005319	OHH C/W RESET OPEN STD	
211005354	OHH ACW OFF OPEN LNG	
211005355	OHH ACW OFF OPEN STD	
211005356	OHH ACW RESET OPEN LG	
211005357	OHH ACW RESET OPEN STD	

Accessory Terminal Blocks



LTF/LTS

215006001	1 OFF ACCESSORY TERMINAL BLOCK
-----------	--------------------------------



Moulded Case Circuit Breakers

Item No	Description	Item No	Description
204105310	XS50NB 10A 2P FC MCCB	204105510	XS50NB 10A 3P FC MCCB
204105315	XS50NB 15A 2P FC MCCB	204105515	XS50NB 15A 3P FC MCCB
204105320	XS50NB 20A 2P FC MCCB	204105520	XS50NB 20A 3P FC MCCB
204105330	XS50NB 30A 2P FC MCCB	204105530	XS50NB 30A 3P FC MCCB
204105340	XS50NB 40A 2P FC MCCB	204105540	XS50NB 40A 3P FC MCCB
204105350	XS50NB 50A 2P FC MCCB	204105550	XS50NB 50A 3P FC MCCB

Auxiliary Switches



211002294	UVT AC 100-120V
211001083	ALARM SWITCH
211001080	1AB AUXILIARY SWITCH
211001082	1AB AUX ALARM SWITCH
211001081	2AB AUXILIARY SWITCH

Undervoltage Trips

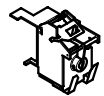

211002300	UVT AC 100-120V TIME DELAY
211002310	UVT AC 100-120V 1SEC TIME DEL
211002311	UVT AC 100-120V 2SEC TIME DEL
211002295	UVT AC 200-240V
211002301	UVT AC 200-240V TIME DELAY
211002306	UVT AC 200-240V 1SEC TIME DEL
211002307	UVT AC 200-240V 2SEC TIME DEL
211002296	UVT AC 380-450V
211002302	UVT AC 380-450V TIME DELAY
211002308	UVT AC 380-450V 1SEC TIME DEL
211002309	UVT AC 380-450V 2SEC TIME DEL
211002298	UVT DC 100-115V
211002299	UVT DC 200-230V
211002297	UVT DC 24V

Shunt Trips



211002287	SHUNT AC 100-115V
211002288	SHUNT AC 200-480V
211002303	SHUNT AC 24V
211002288	SHUNT AC 200-480V
211002304	SHUNT AC 48V
211002292	SHUNT DC 100-115V
211002289	SHUNT DC 12V
211002293	SHUNT DC 200-230V
211002290	SHUNT DC 24V
211002291	SHUNT DC 48V
211002305	SHUNT DC 60V

Connections

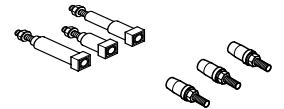

2P FRAME SIZE	
211003274	FC LINE/RC LOAD CONNECTIONS
211003278	1/2 SET SOLDERLESS TERMINALS
211003276	IP20 PLUG IN CONNECTIONS
211003272	PLUG IN CONNECTIONS
211003271	REAR CONNECTIONS
211003275	RC LINE/FC LOAD CONNECTIONS
211003270	SOLDERLESS TERMINAL
211003273	3 MCCB SIDE PLUG IN AUX CONN
3P FRAME SIZE	
211003284	FC LINE/RC LOAD CONNECTIONS
211003288	1/2 SET SOLDERLESS TERMINALS
211003286	IP20 PLUG IN CONNECTIONS
211003282	PLUG IN CONNECTIONS
211003281	REAR CONNECTIONS
211003285	RC LINE/FC LOAD CONNECTIONS
211003280	SOLDERLESS TERMINAL
211003283	5 MCCB SIDE PLUG IN AUX CONN

Terminal Covers

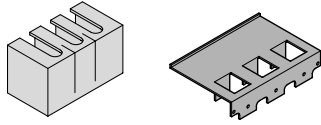

Item No.	Description
2P FRAME SIZE	
211004123	F.C. TERMINAL COVER
211004127	1/2 SET TERMINAL COVERS
211004125	1/2 SET INT/POLE BARRIER
211004124	RC/PI TERMINAL COVER
3P FRAME SIZE	
211004128	F.C. TERMINAL COVER
211004132	1/2 SET TERMINAL COVERS
211004129	RC/PI TERM COVER

Handle Mechanism

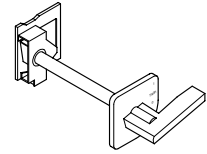

Item No.	Description
3P FRAME SIZE	
211005325	OHH CW OFF OPEN LONG
211005321	OHH C/W OFF OPEN STD
211005323	OHH CW RESET OPEN LG
211005319	OHH C/W RESET OPEN STD
211005339	OHE: HANDLE OPER MECHNSM.

Mechanical Interlocks

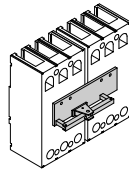

2P FRAME SIZE	
211011009	HANDLE HOLDER & LOCK
211011010	HANDLE HOLDER
3P FRAME SIZE	
211009014	REAR MECHANICAL INTERLOCK
211009090	FRONT MECHANICAL INTERLOCK
211010101	CAM FOR XFH HANDLE
211011010	HANDLE HOLDER

Plug-In Bases

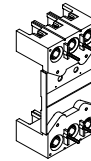

2P FRAME SIZE	
211007061	IP20 PLUG IN BASE
211007031	PLUG IN BASE
211007007	PLUG IN + ATT BARS
211007043	3 BASE SIDE PLUG IN AUX. CONN.
3P FRAME SIZE	
211007062	IP20 PLUG IN BASE
211007032	PLUG IN BASE
211007044	5 BASE SIDE PLUG IN AUX CONN

Double Mounting Bases

2P FRAME SIZE	
211013003	SIZE 2 2P 10-50A DMB
211013004	S2 2P 10-50A DMB+ACC
3P FRAME SIZE	
211013007	SIZE 2 3P 10-50A DMB
211013008	S2 3P 10-50A DMB+ACC

Motor Operators

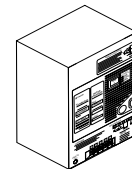

211008078	MOTOR AC 100-110V
211008079	MOTOR AC 200-220V
211008080	MOTOR AC 240V
211008082	MOTOR AC 440V
211008081	MOTOR DC 110V

Accessory Terminal Blocks

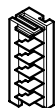

2P FRAME SIZE	
215006001	1 OFF ACCESSORY TERMINAL BLOCK
3P FRAME SIZE	
215006001	1 OFF ACCESSORY TERMINAL BLOCK
215006002	2 OFF ACCESSORY TERMINAL BLOCK



Moulded Case Circuit Breakers

Item No	Description
204103310	XE100NS 10A 2P FC MCCB
204103315	XE100NS 15A 2P FC MCCB
204103320	XE100NS 20A 2P FC MCCB
204103330	XE100NS 30A 2P FC MCCB
204103340	XE100NS 40A 2P FC MCCB
204103350	XE100NS 50A 2P FC MCCB
204103360	XE100NS 60A 2P FC MCCB
204103375	XE100NS 75A 2P FC MCCB
204103311	XE100NS 100A 2P FC MCCB

Item No	Description
204103510	XE100NS 10A 3P FC MCCB
204103515	XE100NS 15A 3P FC MCCB
204103520	XE100NS 20A 3P FC MCCB
204103530	XE100NS 30A 3P FC MCCB
204103540	XE100NS 40A 3P FC MCCB
204103550	XE100NS 50A 3P FC MCCB
204103560	XE100NS 60A 3P FC MCCB
204103575	XE100NS 75A 3P FC MCCB
204103511	XE100NS 100A 3P FC MCCB

Auxiliary Switches



2P FRAME SIZE

211001091	ALARM SWITCH
211001084	1AB AUXILIARY SWITCH
211001088	1AB AUX ALARM SWITCH
211001085	2AB AUXILIARY SWITCH

3P FRAME SIZE

211001083	ALARM SWITCH
211001080	1AB AUXILIARY SWITCH
212001046	1AB AUX ALARM SWITCH
212001048	2AB AUX ALARM SWITCH

Undervoltage Trips

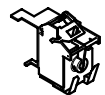

212002063	UVT AC 100-120V
212002115	UVT AC 100-120V TIME DELAY
211002239	UVT AC 100-120V 1SEC TIME DEL
211002248	UVT AC 100-120V 2SEC TIME DEL
212002071	UVT AC 200-240V
212002123	UVT AC 200-240V TIME DELAY
212002202	UVT AC 200-240V 1SEC TIME DEL
212002210	UVT AC 200-240V 2SEC TIME DEL
212002079	UVT AC 380-450V
212002131	UVT AC 380-450V TIME DELAY
212002221	UVT AC 380-450V 1SEC TIME DEL
212002097	UVT DC 100-115V
211002106	UVT DC 200-230V
212002087	UVT DC 24V
211002168	UVT DC 48V
212002177	UVT DC 60V

Shunt Trips



212002002	SHUNT AC 100-115V
212002010	SHUNT AC 200-480V
211002141	SHUNT AC 24V
212002010	SHUNT AC 200-480V
212002152	SHUNT AC 48V
212002046	SHUNT DC 100-115V
212002020	SHUNT DC 12V
212002194	SHUNT DC 125V
212002055	SHUNT DC 200-230V
212002028	SHUNT DC 24V
212002186	SHUNT DC 30V
212002036	SHUNT DC 48V
212002160	SHUNT DC 60V

Connections

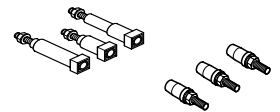

2P FRAME SIZE

211003183	1/2 SET SOLDERLESS TERMINALS
211003044	PLUG IN CONNECTIONS
211003044	PLUG IN CONNECTIONS
211003027	REAR CONNECTIONS
211003003	SOLDERLESS TERMINALS
211003273	3 MCCB SIDE PLUG IN AUX CONN

3P FRAME SIZE

211003184	1/2 SET SOLDERLESS TERMINALS
211003129	IP20 PLUG IN CONNECTIONS
211003045	PLUG IN CONNECTIONS
211003028	REAR CONNECTIONS
211003004	SOLDERLESS TERMINAL
211003283	5 MCCB SIDE PLUG IN AUX CONN

Terminal Covers

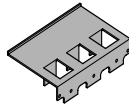
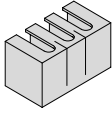

Item No	Description
2P FRAME SIZE	
212004004	F.C. TERMINAL COVER
211004054	1/2 SET TERMINAL COVERS
211004036	1/2 SET INT/POLE BARRIER
211004044	FULL SET I/POLE BARRIER
211004026	RC/PI TERM COVER
3P FRAME SIZE	
212004005	F.C. TERMINAL COVER
212004055	1/2 SET TERMINAL COVERS
211004027	RC/PI TERM COVER

Handle Mechanisms

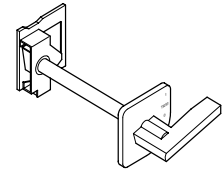

Item No	Description
3P FRAME SIZE	
211005051	OHH ACW OFF OPEN LNG
211005023	OHH ACW OFF OPEN STD
211005037	OHH ACW RESET OPN LG
211005008	OHH ACW RESET OPEN STD
211005044	OHH CW OFF OPEN LONG
211005016	OHH C/W OFF OPEN STD
211005030	OHH CW RESET OPEN LG
211005001	OHH C/W RESET OPEN STD
211005222	OHJ:LEFT:BLACK HANDLE
211005230	OHJ:LEFT:BLACK:IP55 HANDLE
211005238	OHJ:LEFT:RED/YEL HANDLE
211005246	OHJ:LEFT:R/Y:IP55 HANDLE
211005190	OHJ:RIGHT:BLACK HANDLE
211005198	OHJ:RIGHT:BLACK:IP55 HANDLE
211005206	OHJ:RIGHT:RED/YEL HANDLE
211005214	OHJ:RHT:R/Y:IP55 HANDLE
211005254	OHJ:UPPER:BLACK HANDLE
211005262	OHJ:UPPER:BLACK:IP55 HANDLE
211005270	OHJ:UPPER:RED/YEL HANDLE
211005278	OHJ:UPPER:R/Y:IP55 HANDLE
211005152	OHE:HANDLE OPER MECHNSM.

Mechanical Interlocks

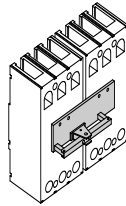

2P FRAME SIZE	
211011009	HANDLE HOLDER & LOCK
211011010	HANDLE HOLDER
3P FRAME SIZE	
211009001	FRONT MECHANICAL INTERLOCK
211009014	REAR MECHANICAL INTERLOCK
211010101	CAM FOR XFH HANDLE
211011009	HANDLE HOLDER & LOCK
211011010	HANDLE HOLDER

Plug-In Bases

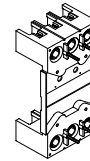

2P FRAME SIZE	
211007061	IP20 PLUG IN BASE
211007031	PLUG IN BASE
211007043	3 BASE SIDE PLUG IN AUX CONN
3P FRAME SIZE	
211007062	IP20 PLUG IN BASE
211007032	PLUG IN BASE
211007007	PLUG IN+ATT BARS
211007044	5 BASE SIDE PLUG IN AUX CONN

Double Mounting Blocks

2P FRAME SIZE	
211013005	SIZE2 2P 60-100A DMB
211013006	S2 2P 60-100A DMB+ACC
3P FRAME SIZE	
211013010	S2 3P 60-100A DMB+ACC

Motor Operators

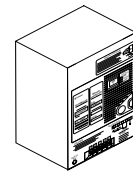

211008010	MOTOR AC 100-110V
211008019	MOTOR AC 200-220V
211008044	AC 240V MOTOR OPERATOR
211008045	MOTOR AC 440V 50HZ
211008058	MOTOR DC 110V

Accessory Terminal Blocks

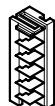

215006001	1 OFF ACCESSORY TERMINAL BLOCK
215006002	2 OFF ACCESSORY TERMINAL BLOCK



Catalogue Item Numbers

XS125CS, XS125NS

Moulded Case Circuit Breakers

Item No	Description	Item No	Description
204110116	XS125CS 16A 1P FC MCCB	204120116	XS125NS 16A 1P FC MCCB
204110120	XS125CS 20A 1P FC MCCB	204120120	XS125NS 20A 1P FC MCCB
204110125	XS125CS 25A 1P FC MCCB	204120125	XS125NS 25A 1P FC MCCB
204110132	XS125CS 32A 1P FC MCCB	204120132	XS125NS 32A 1P FC MCCB
204110140	XS125CS 40A 1P FC MCCB	204120140	XS125NS 40A 1P FC MCCB
204110150	XS125CS 50A 1P FC MCCB	204120150	XS125NS 50A 1P FC MCCB
204110163	XS125CS 63A 1P FC MCCB	204120163	XS125NS 63A 1P FC MCCB
204110180	XS125CS 80A 1P FC MCCB	204120180	XS125NS 80A 1P FC MCCB
204110111	XS125CS 100A 1P FC MCCB	204120111	XS125NS 100A 1P FC MCCB
204110112	XS125CS 125A 1P FC MCCB	204120112	XS125NS 125A 1P FC MCCB

Shunt Trips



211002138	SHUNT 1P AC 100-440V
211002139	SHUNT 1P DC 48-250V

Connections

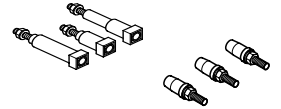

211003008	SOLDERLESS TERMINAL
211003010	REAR CONNECTIONS
211003035	REAR CONNECTIONS
211003187	1/2 SET SOLDERLESS TERMINALS

Terminal Covers

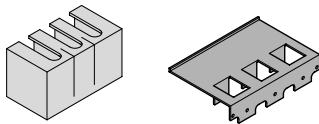

211004097	FC TERMINAL COVER
211004056	1/2 SET FC TERMINAL COVERS

Handle Mechanisms

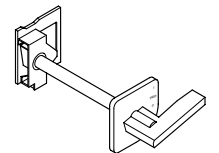

211005153	OHE:HANDLE OPER MECHNSM.
211005159	DOOR FLANGE
211011001	HANDLE LOCK



Catalogue Item Numbers

XS125CJ, XS125NJ, XH125NJ, XS125NN

Moulded Case Circuit Breakers

Item No	Description	Item No	Description
204111520	XS125CJ 20A 3P FC MCCB	204111720	XS125CJ 20A 4P FC MCCB
204111532	XS125CJ 32A 3P FC MCCB	204111732	XS125CJ 32A 4P FC MCCB
204111550	XS125CJ 50A 3P FC MCCB	204111750	XS125CJ 50A 4P FC MCCB
204111563	XS125CJ 63A 3P FC MCCB	204111763	XS125CJ 63A 4P FC MCCB
204111511	XS125CJ 100A 3P FC MCCB	204111711	XS125CJ 100A 4P FC MCCB
204111512	XS125CJ 125A 3P FC MCCB	204111712	XS125CJ 125A 4P FC MCCB
204121520	XS125NJ 20A 3P FC MCCB	204121720	XS125NJ 20A 4P FC MCCB
204121532	XS125NJ 32A 3P FC MCCB	204121732	XS125NJ 32A 4P FC MCCB
204121550	XS125NJ 50A 3P FC MCCB	204121750	XS125NJ 50A 4P FC MCCB
204121563	XS125NJ 63A 3P FC MCCB	204121763	XS125NJ 63A 4P FC MCCB
204121511	XS125NJ 100A 3P FC MCCB	204121711	XS125NJ 100A 4P FC MCCB
204121512	XS125NJ 125A 3P FC MCCB	204121712	XS125NJ 125A 4P FC MCCB
204122520	XS125NJ-G 20A 3P FC GEN SR1116	204122720	XS125NJ-G 20A 4PFC GEN SR1116
204122532	XS125NJ-G 32A 3P FC GEN SR1116	204122732	XS125NJ-G 32A 4PFC GEN SR1116
204122550	XS125NJ-G 50A 3P FC GEN SR1116	204122750	XS125NJ-G 50A 4P FC GEN SR1116
204122563	XS125NJ-G 63A 3P FC GEN SR1116	204122763	XS125NJ-G 63A 4P FC GEN SR1116
204122511	XS125NJ-G 100A 3PFC GEN SR1116	204122711	XS125NJ-G 100A 4PFC GEN SR1116
204122512	XS125NJ-G 125A 3PFC GEN SR1116	204122712	XS125NJ-G 125A 4PFC GEN SR1116
204127520	XS125NJ 20A 3P FC SRX5	204127720	XS125NJ 20A 4P FC SRX5
204127532	XS125NJ 32A 3P FC SRX5	204127732	XS125NJ 32A 4P FC SRX5
204127550	XS125NJ 50A 3P FC SRX5	204127750	XS125NJ 50A 4P FC SRX5
204127563	XS125NJ 63A 3P FC SRX5	204127763	XS125NJ 63A 4P FC SRX5
204127511	XS125NJ 100A 3P FC SRX5	204127711	XS125NJ 100A 4P FC SRX5
204127512	XS125NJ 125A 3P FC SRX5	204127712	XS125NJ 125A 4P FC SRX5
204123520	XS125NJ 20A 3P FC D600		
204123532	XS125NJ 32A 3P FC DC 600		
204123550	XS125NJ 50A 3P FC D600		
204123563	XS125NJ 63A 3P FC D600		
204123511	XS125NJ 100A 3P FC D600		
204123512	XS125NJ 125A 3P FC D600		
204124520	XH125NJ 20A 3P FC MCCB	204124720	XH125NJ 20A 4P FC MCCB
204124532	XH125NJ 32A 3P FC MCCB	204124732	XH125NJ 32A 4P FC MCCB
204124550	XH125NJ 50A 3P FC MCCB	204124750	XH125NJ 50A 4P FC MCCB
204124563	XH125NJ 63A 3P FC MCCB	204124763	XH125NJ 63A 4P FC MCCB
204124511	XH125NJ 100A 3P FC MCCB	204124711	XH125NJ 100A 4P FC MCCB
204124512	XH125NJ 125A 3P FC MCCB	204124712	XH125NJ 125A 4P FC MCCB
204192512	XS125NN 125A 3P FC ISOLATOR	204192712	XS125NN 125A 4P FC ISOLATOR



Catalogue Item Numbers

XS125CJ, XS125NJ, XH125NJ, XS125NN

Auxiliary Switches



Item No	Description
3P FRAME SIZE	
212001067	ALARM SWITCH
211001002	1AB AUXILIARY SWITCH
212001039	1AB AUX ALARM SWITCH
211001012	2AB AUXILIARY SWITCH
4P FRAME SIZE	
211001078	ALARM SWITCH
211001076	1AB AUXILIARY SWITCH
211001079	1AB AUX ALARM SWITCH
211001077	2AB AUXILIARY SWITCH



Shunt Trips

212002003	SHUNT AC 100-115V
212002011	SHUNT AC 200-480V
212002143	SHUNT AC 24V
212002011	SHUNT AC 200-480V
212002153	SHUNT AC 48V
212002048	SHUNT DC 100-115V
212002021	SHUNT DC 12V
212002195	SHUNT DC 125V
212002056	SHUNT DC 200-230V
212002029	SHUNT DC 24V
212002187	SHUNT DC 30V
211002037	SHUNT DC 48V
212002161	SHUNT DC 60V

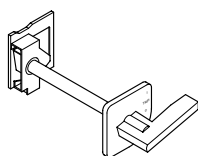

Handle Mechanisms

211005175	ANTI-CL/WISE TAMPER PROOF HAND
211005169	CLOCKWISE TAMPER PROOF HANDLE
211005052	OHH ACW OFF OPEN LNG
211005024	OHH ACW OFF OPEN STD
211005038	OHH ACW RESET OPN LG
211005009	OHH ACW RESET OPEN STD
212005045	OHH CW OFF OPEN LONG
212005017	OHH C/W OFF OPEN STD
212005031	OHH CW RESET OPEN LG
212005002	OHH C/W RESET OPEN STD
211005223	OHJ:LEFT:BLACK HANDLE
211005231	OHJ:LEFT:BLACK:IP55 HANDLE
211005239	OHJ:LEFT:RED/YEL HANDLE
211005247	OHJ:LEFT:R/Y:IP55 HANDLE
211005191	OHJ:RIGHT:BLACK HANDLE
211005199	OHJ:RIGHT:BLACK:IP55 HANDLE
211005207	OHJ:RIGHT:RED/YEL HANDLE
211005215	OHJ:RHT:R/Y:IP55 HANDLE
211005255	OHJ:UPPER:BLACK HANDLE
211005263	OHJ:UPPER:BLACK:IP55 HANDLE
211005271	OHJ:UPPER:RED/YEL HANDLE
211005279	OHJ:UPPER:R/Y:IP55 HANDLE
211005153	OHE:HANDLE OPER MECHNSM.

Undervoltage Trips



Item No	Description
212002064	UVT AC 100-120V
212002116	UVT AC 100-120V TIME DELAY
212002240	UVT AC 100-115V ISEC TIME DEL
212002249	UVT AC 100-115V 2SEC TIME DEL
212002072	UVT AC 200-240V
212002124	UVT AC 200-240V TIME DELAY
212002203	UVT AC 200-240V 1SEC TIME DEL
212002211	UVT AC 200-240V 2SEC TIME DEL
212002080	UVT AC 380-450V
212002132	UVT AC 380-450V TIME DELAY
212002222	UVT AC 380-450V 1SEC TIME DEL
212002232	UVT AC 380-450V 2SEC TIME DEL
212002098	UVT DC 100-115V
212002107	UVT DC 200-230V
212002088	UVT DC 24V
211002169	UVT DC 48V
212002178	UVT DC 60V

Connections

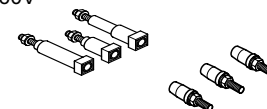

3P FRAME SIZE	
211003002	ATTACH BUSBARS
211003105	FC LINE/RC LOAD CONNECTIONS
211003187	1/2 SET SOLDERLESS TERMINALS
211003132	IP20 PLUG IN CONNECTIONS
211003050	PLUG IN CONNECTIONS
211003035	REAR CONNECTIONS
211003215	RC LINE/FC LOAD CONNECTIONS
211003008	SOLDERLESS TERMINAL
215003072	5 MCCB SIDE PLUG IN AUX CONN
4P FRAME SIZE	
211003001	ATTACH BUSBARS
211003106	FC LINE/RC LOAD CONNECTIONS
211003188	1/2 SET SOLDERLESS TERMINALS
211003051	PLUG IN CONNECTIONS
211003036	REAR CONNECTIONS
211003300	RC LINE/FC LOAD CONNECTIONS
211003009	SOLDERLESS TERMINAL
215003072	5 MCCB SIDE PLUG IN AUX CONN

Motor Operators

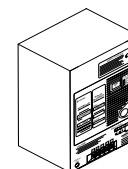

211008089	XMB2-C MOTOR AC 100-110V
211008090	XMB2-C MOTOR AC 200-220V
211008091	XMB2-C MOTOR AC 240V
211008092	XMB2-C MOTOR AC 440V
211008093	XMB2-C MOTOR 100V



Catalogue Item Numbers

XS125CJ, XS125NJ, XH125NJ, XS125NN

Mechanical Interlocks

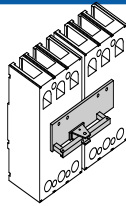

Item No	Description
3P FRAME SIZE	
211009002	FRONT MECHANICAL INTERLOCK
211009015	REAR MECHANICAL INTERLOCK
211009052	REAR MECH INTLK+ACC
211009130	REAR MECH I'LOCK+TEMTRANSFER
211009144	P/IN MECH I'LOCK+TEMTRANSFER
211009075	P/IN I'LOCK+ACCESSORIES
4P FRAME SIZE	
211009009	FRONT MECHANICAL INTERLOCK
211009016	REAR MECHANICAL INTERLOCK
211009053	REAR MECH INTLK+ACC
211009131	REAR MECH I'LOCK+TEMTRANSFER
211009076	P/IN I'LOCK+ACCESSORIES
3P & 4P FRAME SIZE	
211010001	CASTELL A LOCK IN CLOSE
211010015	CASTELL B LOCK IN CLOSE
211010039	CASTELL SPEC LOCK IN CLOSE
211010050	CASTELL A LOCK IN OPEN
211010061	CASTELL B LOCK IN OPEN
211010086	CASTELL SPEC LOCK IN OPEN
211010101	CAM FOR XFH HANDLE
211011001	HANDLE LOCK
211011011	ADJMNT SEALING FACILITY

Terminal Covers

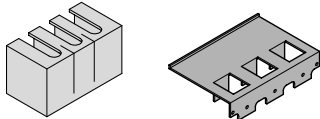

3P FRAME SIZE	
211004028	RC/PI TERM COVER
211004038	1/2 SET INT/POLE BARRIER
211004039	1/2 SET INT/POLE BARRIER
211004045	FULL SET I/POLE BARRIER
211004113	IP20 FRONT COVER
211004120	THERMAL ADJ BLANK
212004006	F.C. TERMINAL COVER
212004057	1/2 SET TERMINAL COVERS
212004058	1/2 SET TERMINAL COVERS
4P FRAME SIZE	
211004029	RC/PI TERM COVER
211004039	1/2 SET INT/POLE BARRIER
211004049	FULL SET I/POLE BARRIER
211004120	THERMAL ADJ BLANK
212004007	F.C. TERMINAL COVER
212004058	1/2 SET TERMINAL COVERS

Accessory Terminal Blocks

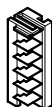

215006001	1 OFF ACCESSORY TERMINAL BLOCK
215006002	2 OFF ACCESSORY TERMINAL BLOCK

Plug-In Bases

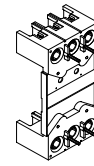

Item No	Description
211007063	
211007018	IP20 PLUG IN BASE
211007033	IP20 PI+ATT BARS
211007008	PLUG IN BASE
211007111	PLUG IN+ATT BARS
211007045	PIB+R/ANGLE ATT BARS/125A/3P
	5 BASE SIDE PLUGIN AUX CONN
211007064	
211007137	IP20 PLUG IN BASE
211007034	PIB+IP20+ATTACH BARS/125A/4P
211007133	PLUG IN BASE
211007045	PIB+ATTACH BARS/125A/4P
	5 BASE SIDE PLUGIN AUX CONN

Double Mounting Blocks

3P FRAME SIZE ONLY	
211013011	SIZE3 3P 20-50A DMB
211013012	S3 DMB+ACC 3P 20-50A
211013013	SIZE3 3P 60-125A DMB
211013014	S3DMB+ACC 3P 60-125A
211013023	S3DMB IP20,3P,20-50A
211013024	S3DMB IP20 60-125A3P



Catalogue Item Numbers

XS160NJ, XS160NN, XE225NS, XS250NJ, XS250NN

Moulded Case Circuit Breakers

Item No	Description	Item No	Description
204220516	XS160NJ 160A 3P FC MCCB	204220716	XS160NJ 160A 4P FC MCCB
204219516	XS160NJ-G 160A 3PFC GEN SR1116	204219716	XS160NJ-G 160A 4PFC GEN SR1116
204290516	XS160NN 160A 3P FC ISOLATOR	204290716	XS160NN 160A 4P FC ISOLATOR
204200512	XE225NS 125A 3P FC MCCB		
204200515	XE225NS 150A 3P FC MCCB		
204200517	XE225NS 175A 3P FC MCCB		
204200520	XE225NS 200A 3P FC MCCB		
204200522	XE225NS 225A 3P FC MCCB		
204221516	XS250NJ 160A 3P FC MCCB	204221716	XS250NJ 160A 4P FC MCCB
204221525	XS250NJ 250A 3P FC MCCB	204221725	XS250NJ 250A 4P FC MCCB
204222525	XS250NJ-G 250A 3PFC GEN SR1116	204222725	XS250NJ-G 250A 4PFC GEN SR1116
204291525	XS250NN 250A 3P FC ISOLATOR	204291725	XS250NN 250A 4P FC ISOLATOR

Auxiliary Switches



212001068	ALARM SWITCH
212001003	1AB AUXILIARY SWITCH
212001040	1AB AUX ALARM SWITCH
212001013	2AB AUXILIARY SWITCH

Undervoltage Trips

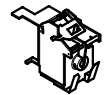

212002065	UVT AC 100-120V
212002117	UVT AC 100-120V TIME DELAY
212002241	UVT AC 100-120V 1SEC TIME DEL
212002250	UVT AC 100-120V 2SEC TIME DEL
212002073	UVT AC 200-240V
212002125	UVT AC 200-240V TIME DELAY
212002204	UVT AC 200-240V 1SEC TIME DEL
212002213	UVT AC 200-240V 2SEC TIME DEL
212002081	UVT AC 380-450V
212002133	UVT AC 380-450V TIME DELAY
211002223	UVT AC 380-450V 1SEC TIME DEL
212002233	UVT AC 380-450V 2SEC TIME DEL
212002099	UVT DC 100-115V
211002109	UVT DC 200-230V
212002091	UVT DC 24V
211002170	UVT DC 48V
212002179	UVT DC 60V

Shunt Trips



212002004	SHUNT AC 100-115V
212002012	SHUNT AC 200-480V
212002144	SHUNT AC 24V
212002012	SHUNT AC 200-480V
212002154	SHUNT AC 48V
212002049	SHUNT DC 100-115V
212002022	SHUNT DC 12V
212002196	SHUNT DC 125V
212002057	SHUNT DC 200-230V
212002030	SHUNT DC 24V
212002188	SHUNT DC 30V
212002038	SHUNT DC 48V
212002162	SHUNT DC 60V

Connections

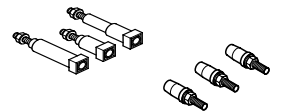

3P FRAME SIZE	
211003013	ATTACH BUSBARS
211003107	FC LINE/RC LOAD CONNECTIONS
212003189	1/2 SET SOLDERLESS TERMINALS
212003134	IP20 PLUG IN CONNECTIONS
212003052	PLUG IN CONNECTIONS
211003037	REAR CONNECTIONS
211003109	RC LINE/FC LOAD CONNECTIONS
212003011	SOLDERLESS TERMINAL
215003072	5 MCCB SIDE PLUG IN AUX CONN
4P FRAME SIZE	
211003014	ATTACH BUSBARS
211003108	FC LINE/RC LOAD CONNECTIONS
212003190	1/2 SET SOLDERLESS TERMINALS
212003135	IP20 PLUG IN CONNECTIONS
212003053	PLUG IN CONNECTIONS
211003038	REAR CONNECTIONS
211003118	RC LINE/FC LOAD CONNECTIONS
212003012	SOLDERLESS TERMINAL
215003072	5 MCCB SIDE PLUG IN AUX CONN

Terminal Covers

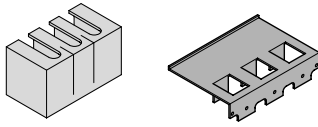

Item No	Description
3P FRAME SIZE	
211004008	F.C. TERMINAL COVER
211004032	RC/PI TERM COVER
211004038	1/2 SET INT/POLE BARRIER
211004045	FULL SET I/POLE BARRIER
211004059	1/2 SET TERMINAL COVERS
211004114	IP20 FRONT COVER
4P FRAME SIZE	
211004009	F.C. TERMINAL COVER
211004033	RC/PI TERM COVER
211004039	1/2 SET INT/POLE BARRIER
211004049	FULL SET I/POLE BARRIER
211004060	1/2 SET TERMINAL COVERS
211004137	IP20 FRONT COVER

Mechanical Interlocks

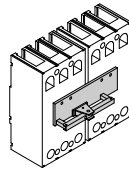

3P FRAME SIZE	
211009010	FRONT MECHANICAL INTERLOCK
211009017	REAR MECHANICAL INTERLOCK
211009054	REAR MECH INTLK+ACC
211009132	REAR MECH I'LOCK+TEMTRANSFER
211009077	P/IN I'LOCK+ACCESSORIES
4P FRAME SIZE	
211009011	FRONT MECHANICAL INTERLOCK
211009018	REAR MECHANICAL INTERLOCK
211009055	REAR MECH INTLK+ACC
211009133	REAR MECH I'LOCK+TEMTRANSFER
211009107	P/IN I'LOCK+ACCESSORIES
3P & 4P FRAME SIZE	
211010003	CASTELL A LOCK IN CLOSE
211010016	CASTELL B LOCK IN CLOSE
211010040	CASTELL SPEC LOCK IN CLOSE
211010051	CASTELL A LOCK IN OPEN
211010062	CASTELL B LOCK IN OPEN
211010087	CASTELL SPEC LOCK IN OPEN
211010101	CAM FOR XFH HANDLE
211011002	HANDLE LOCK
211011012	ADMNT SEALING FACILITY

Accessory Terminal Blocks

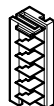

215006001	1 OFF ACCESSORY TERMINAL BLOCK
215006002	2 OFF ACCESSORY TERMINAL BLOCK

Handle Mechanisms

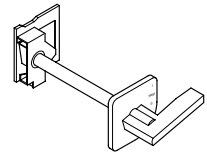

Item No	Description
211005176	ANTI-CL/WISE TAMPER PROOF HAND
211005170	CLOCKWISE TAMPER PROOF HANDLE
211005053	OHH ACW OFF OPEN LNG
211005025	OHH ACW OFF OPEN STD
211005039	OHH ACW RESET OPN LG
211005010	OHH ACW RESET OPEN STD
212005046	OHH CW OFF OPEN LONG
212005018	OHH C/W OFF OPEN STD
212005032	OHH CW RESET OPEN LG
212005003	OHH C/W RESET OPEN STD
211005224	OHJ:LEFT:BLACK HANDLE
211005232	OHJ:LEFT:BLACK:IP55 HANDLE
211005240	OHJ:LEFT:RED/YEL HANDLE
211005248	OHJ:LEFT:R/Y:IP55 HANDLE
211005192	OHJ:RIGHT:BLACK HANDLE
211005200	OHJ:RIGHT:BLACK:IP55 HANDLE
211005208	OHJ:RIGHT:RED/YEL HANDLE
211005216	OHJ:RHT:R/Y:IP55 HANDLE
211005256	OHJ:UPPER:BLACK HANDLE
211005264	OHJ:UPPER:BLACK:IP55 HANDLE
211005272	OHJ:UPPER:RED/YEL HANDLE
211005280	OHJ:UPPER:R/Y:IP55 HANDLE
211005154	OHE:HANDLE OPER MECHNISM.

Plug-In Bases

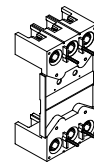

3P FRAME SIZE	
211007065	IP20 PLUG IN BASE
211007019	IP20 PI+ATT BARS
211007035	PLUG IN BASE
211007009	PLUG IN+ATT BARS
211007108	PIB+R/ANGLE ATT BARS/250A/3P
215007049	5 BASE SIDE PLUG IN AUX CONN
4P FRAME SIZE	
211007066	IP20 PLUG IN BASE
211007138	PIB+IP20+ATTACH BARS/250A/4P
211007036	PLUG IN BASE
211007134	PIB+ATTACH BARS/250A/4P
215007049	5 BASE SIDE PLUG IN AUX CONN

Motor Operators

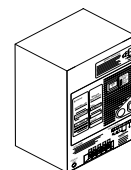

211008095	XMB3-C MOTOR AC 100-110V
211008096	XMB3-C MOTOR AC 200-220V
211008097	XMB3-C MOTOR AC 240V
211008098	XMB3-C MOTOR AC 440V
211008099	XMB3-C MOTOR DC 100V



Moulded Case Circuit Breakers

Item No	Description	Item No	Description
204223516	XH160NJ 160A 3P FC MCCB	204223716	XH160NJ 160A 4P FC MCCB
204226516	XH160PJ 160A 3P FC MCCB	204226716	XH160PJ 160A 4P FC MCCB
204225516	XS250PJ 160A 3P FC MCCB	204225716	XS250PJ 160A 4P FC MCCB
204225525	XS250PJ 250A 3P FC MCCB	204225725	XS250PJ 250A 4P FC MCCB
204224516	XH250NJ 160A 3P FC MCCB	204224716	XH250NJ 160A 4P FC MCCB
204224525	XH250NJ 250A 3P FC MCCB	204224725	XH250NJ 250A 4P FC MCCB

Auxiliary Switches



212001068	ALARM SWITCH
212001003	1AB AUXILIARY SWITCH
212001040	1AB AUX ALARM SWITCH
212001013	2AB AUXILIARY SWITCH

Undervoltage Trips

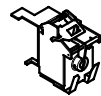

212002065	UVT AC 100-120V
212002117	UVT AC 100-120V TIME DELAY
212002241	UVT AC 100-120V 1SEC TIME DEL
212002250	UVT AC 100-120V 2SEC TIME DEL
212002073	UVT AC 200-240V
212002125	UVT AC 200-240V TIME DELAY
212002204	UVT AC 200-240V 1SEC TIME DEL
212002213	UVT AC 200-240V 2SEC TIME DEL
212002081	UVT AC 380-450V
212002133	UVT AC 380-450V TIME DELAY
211002223	UVT AC 380-450V 1SEC TIME DEL
212002233	UVT AC 380-450V 2SEC TIME DEL
212002099	UVT DC 100-115V
211002109	UVT DC 200-230V
212002091	UVT DC 24V
211002170	UVT DC 48V
212002179	UVT DC 60V

Shunt Trips



212002004	SHUNT AC 100-115V
212002012	SHUNT AC 200-480V
212002144	SHUNT AC 24V
212002012	SHUNT AC 200-480V
212002154	SHUNT AC 48V
212002049	SHUNT DC 100-115V
212002022	SHUNT DC 12V
212002196	SHUNT DC 125V
212002057	SHUNT DC 200-230V
212002030	SHUNT DC 24V
212002188	SHUNT DC 30V
212002038	SHUNT DC 48V
212002162	SHUNT DC 60V

Connections

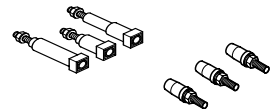

3P FRAME SIZE	
211003013	ATTACH BUSBARS
211003233	D/O CONNECTIONS
211003107	FC LINE/RC LOAD CONNECTIONS
211003291	1/2 SET SOLDERLESS TERMINALS
211003136	IP20 PLUG IN CONNECTIONS
211003054	PLUG IN CONNECTIONS
211003037	REAR CONNECTIONS
211003109	RC LINE/FC LOAD CONNECTIONS
211003290	SOLDERLESS TERMINAL
215003072	5 MCCB SIDE PLUG IN AUX CONN
4P FRAME SIZE	
211003014	ATTACH BUSBARS
211003235	D/O CONNECTIONS
211003108	FC LINE/RC LOAD CONNECTIONS
211003293	1/2 SET SOLDERLESS TERMINALS
211003138	IP20 PLUG IN CONNECTIONS
211003055	PLUG IN CONNECTIONS
211003038	REAR CONNECTIONS
211003118	RC LINE/FC LOAD CONNECTIONS
211003292	SOLDERLESS TERMINAL
215003072	5 MCCB SIDE PLUG IN AUX CONN

Accessory Terminal Blocks

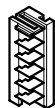

215006001	1 OFF ACCESSORY TERMINAL BLOCK
215006002	2 OFF ACCESSORY TERMINAL BLOCK

Terminal Covers

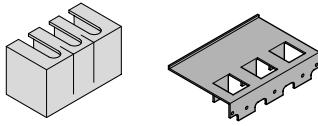

Item No	Description
3P FRAME SIZE	
211004010	F.C. TERMINAL COVER
211004030	RC/PI TERM COVER
211004031	RC/PI TERM COVER
211004040	1/2 SET INT/POLE BARRIER
211004048	FULL SET I/POLE BARRIER
211004061	1/2 SET TERMINAL COVERS
211004089	IP20 FRONT COVER
4P FRAME SIZE	
211004011	F.C. TERMINAL COVER
211004031	RC/PI TERM COVER
211004041	1/2 SET INT/POLE BARRIER
211004062	1/2 SET TERMINAL COVERS
211004095	FULL SET I/POLE BARRIER

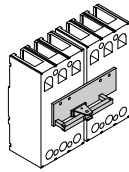

Mechanical Interlocks

3P FRAME SIZE	
211009010	FRONT MECHANICAL INTERLOCK
211009019	REAR MECHANICAL INTERLOCK
211009056	REAR MECH INTLK+ACC
211009066	R MCH INTLK+TMTRC
211009134	REAR MECH I'LOCK+TEMTRANSFER
211009078	P/IN I'LOCK+ACCESSORIES
4P FRAME SIZE	
211009011	FRONT MECHANICAL INTERLOCK
211009020	REAR MECHANICAL INTERLOCK
211009057	REAR MECH INTLK+ACC
211009135	REAR MECH I'LOCK+TEMTRANSFER
211009046	P/IN I'LOCK+ACCESSORIES
3P & 4P FRAME SIZE	
211010004	CASTELL A LOCK IN CLOSE
211010018	CASTELL B LOCK IN CLOSE
211010041	CASTELL SPEC LOCK IN CLOSE
211010052	CASTELL A LOCK IN OPEN
211010063	CASTELL B LOCK IN OPEN
211010088	CASTELL SPEC LOCK IN OPEN
211010101	CAM FOR XFH HANDLE
211011002	HANDLE LOCK
211011012	ADJMNT SEALING FACILITY

Drawout Chassis

3P FRAME SIZE	
211014001	DRAW OUT CHASSIS
211014003	D/O CHASSIS+POS SWITCH
4P FRAME SIZE	
211014005	DRAW OUT CHASSIS
211014007	D/O CHASSIS+POS SWITCH

Handle Mechanisms

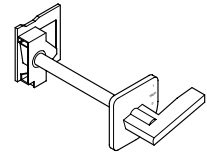

Item No	Description
211005177	ANTI-CL/WISE TAMPER PROOF HAND
211005171	CLOCKWISE TAMPER PROOF HANDLE
211005054	OHH ACW OFF OPEN LNG
211005026	OHH ACW OFF OPEN STD
211005040	OHH ACW RESET OPN LG
211005011	OHH ACW RESET OPEN STD
212005047	OHH CW OFF OPEN LONG
212005019	OHH C/W OFF OPEN STD
212005033	OHH CW RESET OPEN LG
212005004	OHH C/W RESET OPEN STD
211005225	OHJ:LEFT:BLACK HANDLE
211005233	OHJ:LEFT:BLACK:IP55 HANDLE
211005241	OHJ:LEFT:RED/YEL HANDLE
211005249	OHJ:LEFT:R/Y:IP55 HANDLE
211005193	OHJ:RIGHT:BLACK HANDLE
211005201	OHJ:RIGHT:BLACK:IP55 HANDLE
211005209	OHJ:RIGHT:RED/YEL HANDLE
211005217	OHJ:RHT:R/Y:IP55 HANDLE
211005257	OHJ:UPPER:BLACK HANDLE
211005265	OHJ:UPPER:BLACK:IP55 HANDLE
211005273	OHJ:UPPER:RED/YEL HANDLE
211005281	OHJ:UPPER:R/Y:IP55 HANDLE
211005154	OHE:HANDLE OPER MECHNSM.

Plug-In Bases

3P FRAME SIZE	
211007065	IP20 PLUG IN BASE
211007019	IP20 PI+ATT BARS
211007035	PLUG IN BASE
211007009	PLUG IN+ATT BARS
211007108	PIB+R/ANGLE ATT BARS/250A/3P
215007049	5 BASE SIDE PLUG IN AUX CONN
4P FRAME SIZE	
211007066	IP20 PLUG IN BASE
211007138	PIB+IP20+ATTACH BARS/250A/4P
211007036	PLUG IN BASE
211007134	PIB+ATTACH BARS/250A/4P
215007049	5 BASE SIDE PLUG IN AUX CONN

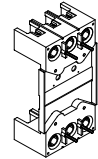

Motor Operators

211008100	XMB3-C MOTOR AC 100-110V
211008101	XMB3-C MOTOR AC 200-220V
211008102	XMB3-C MOTOR AC 240V
211008103	XMB3-C MOTOR AC 440V
211008103	XMB3-C MOTOR AC 440V
211008104	XMB3-C MOTOR DC 100V

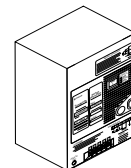



Catalogue Item Numbers

XH250PE, XE400NS, XS400CJ, XS400NJ, XS400SE-C, XS400SE, XH400SE, XS400NN

Moulded Case Circuit Breakers

Item No	Description	Item No	Description
204300525	XE400NS 250A 3P FC MCCB		
204300530	XE400NS 300A 3P FC MCCB		
204300535	XE400NS 350A 3P FC MCCB		
204300540	XE400NS 400A 3P FC MCCB		
204310525	XS400CJ 250A 3P FC MCCB	204310725	XS400CJ 250A 4P FC MCCB
204310540	XS400CJ 400A 3P FC MCCB	204310740	XS400CJ 400A 4P FC MCCB
204311525	XS400CJ 250A 3P FC GEN MCCB	204311725	XS400CJ/250A 4P FC GEN MCCB
204311540	XS400CJ 400A 3P FC GEN MCCB	204311740	XS400CJ 400A 4P FC GEN MCCB
204320525	XS400NJ 250A 3P FC MCCB	204320725	XS400NJ 250A 4P FC MCCB
204320540	XS400NJ 400A 3P FC MCCB	204320740	XS400NJ 400A 4P FC MCCB
204321525	XS400NJ-G 250A 3P FC GEN MCCB	204321725	XS400NJ-G 250A 4P FC GEN MCCB
204321540	XS400NJ-G 400A 3P FC GEN MCCB	204321740	XS400NJ-G 400A 4P FC GEN MCCB
204390540	XS400NN 400A 3P FC ISOLATOR	204390740	XS400NN 400A 4P FC ISOLATOR
204280525	XH250PE 250A 3P FC MCCB	204280725	XH250PE 250A 4P FC MCCB
204281525	XH250PE 250A &AI 3P FC MCCB	204281725	XH250PE 250A &AI 4P FC MCCB
204282525	XH250PE 250A &AP 3P FC MCCB	204282725	XH250PE 250A &AP 4P FC MCCB
204282725	XH250PE 250A &AP 4P FC MCCB	204282725	XH250PE 250A &AP 4P FC MCCB
204283525	XH250PE 250A & AH 3P FC MCCB	204283725	XH250PE 250A & AH 4P FC MCCB
204284525	XH250PE 250A &AH&AP 3P FC MCCB	204284725	XH250PE 250A &AH&AP 4P FC MCCB
204340525	XS400SE-C 250A 3P FC MCCB	204340725	XS400SE-C 250A 4P FC MCCB
204340540	XS400SE-C 400A 3P FC MCCB	204340740	XS400SE-C 400A 4P FC MCCB
204341525	XS400SE-C 250A & AI 3P FC MCCB	204341725	XS400SE-C 250A & AI 4P FC MCCB
204341540	XS400SE-C 400A & AI 3P FC MCCB	204341740	XS400SE-C 400A & AI 4P FC MCCB
204342525	XS400SE-C 250A & AP 3P FC MCCB	204342725	XS400SE-C 250A & AP 4P FC MCCB
204342540	XS400SE-C 400A & AP 3P FC MCCB	204342740	XS400SE-C 400A & AP 4P FC MCCB
204343525	XS400SE-C 250A & AH 3P FC MCCB	204343725	XS400SE-C 250A & AH 4P FC MCCB
204343540	XS400SE-C 400A & AH 3P FC MCCB	204343740	XS400SE-C 400A & AH 4P FC MCCB
204370525	XS400SE 250A 3P FC MCCB	204370725	XS400SE 250A 4P FC MCCB
204370540	XS400SE 400A 3P FC MCCB	204370740	XS400SE 400A 4P FC MCCB
204373525	XS400SE 250A & AI 3P FC MCCB	204373725	XS400SE 250A &AI 4P FC MCCB
204373540	XS400SE 400A & AI 3P FC MCCB	204373740	XS400SE 400A & AI 4P FC MCCB
204374525	XS400SE 250A & AP 3P FC MCCB	204374725	XS400SE 250A & AP 4P FC MCCB
204374540	XS400SE 400A & AP 3P FC MCCB	204374740	XS400SE 400A & AP 4P FC MCCB
204375525	XS400SE 250A & AH 3P FC MCCB	204375725	XS400SE 250A & AH 4P FC MCCB
204375540	XS400SE 400A & AH 3P FC MCCB	204375740	XS400SE 400A &AH 4P FC MCCB
204380525	XH400SE 250A 3P FC MCCB	204380725	XH400SE 250A 4P FC MCCB
204380540	XH400SE 400A 3P FC MCCB	204380740	XH400SE 400A 4P FC MCCB
204383525	XH400SE 250A & AI 3P FC MCCB	204383725	XH400SE 250A &AI 4P FC MCCB
204383540	XH400SE 400A & AI 3P FC MCCB	204383740	XH400SE 400A & AI 4P FC MCCB
204384540	XH400SE 400A & AP 3P FC MCCB	204384725	XH400SE 250A & AP 4P FC MCCB
204384525	XH400SE 250A & AP 3P FC MCCB	204384740	XH400SE 400A & AP 4P FC MCCB
204385540	XH400SE 400A & AH 3P FC MCCB	204385725	XH400SE 250A & AH 4P FC MCCB
204385525	XH400SE 250A & AH 3P FC MCCB	204385740	XH400SE 400A & AH 4P FC MCCB



Catalogue Item Numbers

XH250PE, XE400NS, XS400CJ, XS400NJ, XS400SE-C, XS400SE, XH400SE, XS400NN

Auxiliary Switches



Item No	Description
212001069	ALARM SWITCH
212001004	1AB AUXILIARY SWITCH
212001041	1AB AUX ALARM SWITCH
212001100	1AB AUX 2 ALARM SWITCH
212001099	2 ALARM SWITCH
212001014	2AB AUXILIARY SWITCH
212001051	2AB AUX ALARM SWITCH
212001024	3AB AUXILIARY SWITCH

Undervoltage Trips

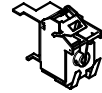

Item No	Description
211002066	UVT AC 100-120V
211002118	UVT AC 100-120V TIME DELAY
211002242	UVT AC 100-120V 1SEC TIME DEL
211002251	UVT AC 100-120V 1SEC TIME DEL
211002074	UVT AC 200-240V
211002126	UVT AC 200-240V TIME DELAY
211002205	UVT AC 200-240V 1SEC TIME DEL
211002214	UVT AC 200-240V 2SEC TIME DEL
211002312	UVT (IND) 240V
211002082	UVT AC 380-450V
211002134	UVT AC 380-450V TIME DELAY
211002225	UVT AC 380-450V 1SEC TIME DEL
211002234	UVT AC 380-450V 2SEC TIME DEL
212002100	UVT DC 100-115V
211002110	UVT DC 200-230V
211002092	UVT DC 24V
212002172	UVT DC 48V
212002180	UVT DC 60V

Shunt Trips



Item No	Description
211002005	SHUNT AC 100-115V
211002013	SHUNT AC 200-480V
212002145	SHUNT AC 24V
211002013	SHUNT AC 200-480V
212002155	SHUNT AC 48V
211002050	SHUNT DC 100-115V
211002023	SHUNT DC 12V
212002197	SHUNT DC 125V
211002058	SHUNT DC 200-230V
212002031	SHUNT DC 24V
212002189	SHUNT DC 30V
211002039	SHUNT DC 48V
212002163	SHUNT DC 60V

Connections

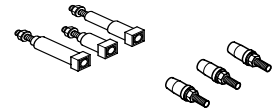

3P FRAME SIZE	
211003017	ATTACH BUSBARS
211003237	D/O CONNECTIONS
211003101	FC LINE/RC LOAD CONNECTIONS
212003191	1/2 SET SOLDERLESS TERMINALS
211003139	IP20 PLUG IN CONNECTIONS
211003056	PLUG IN CONNECTIONS
211003032	REAR CONNECTIONS
211003113	RC LINE/FC LOAD CONNECTIONS
212003015	SOLDERLESS TERMINAL
211003033	REAR CONNECTIONS
211003102	FC LINE/RC LOAD CONNECTIONS
211003213	T/WAY CON PSTS(1250ABUSBAR)
211003126	TEMWAY CONN POSTS 800A BUSBAR
215003072	5 MCCB SIDE PLUG IN AUX CONN
4P FRAME SIZE	
211003018	ATTACH BUSBARS
211003240	D/O CONNECTION
211003102	FC LINE/RC LOAD CONNECTIONS
212003220	1/2 SET SOLDERLESS TERMINALS
211003140	IP20 PLUG IN CONNECTIONS
211003057	PLUG IN CONNECTIONS
211003033	REAR CONNECTIONS
211003114	RC LINE/FC LOAD CONNECTIONS
212003016	SOLDERLESS TERMINAL
211003033	REAR CONNECTIONS
211003102	FC LINE/RC LOAD CONNECTIONS
215003072	5 MCCB SIDE PLUG IN AUX CONN

Motor Operators

211008007	MOTOR DC 48V
211008015	AC 100-110V MOTOR OPERATOR
211008023	AC 220V MOTOR OPERATOR
211008042	AC 240V MOTOR OPERATOR
211008053	DC 24V MOTOR OPERATOR
211008056	MOTOR DC 110V
211008062	MOTOR DC 24V LRC 240V
211008086	AC 440V 50/60HZ MOTOR OPERATOR



Catalogue Item Numbers

XH250PE, XE400NS, XS400CJ, XS400NJ, XS400SE-C, XS400SE, XH400SE, XS400NN

Terminal Covers

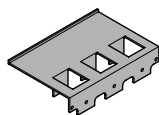
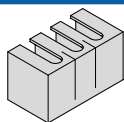

Item No	Description
3P FRAME SIZE	
212004074	F.C. TERM.COVER (NO ATT.BAR)
212004016	F.C. TERM.COVER (+ATT.BAR)
212004067	1/2 SET TERM.COVER (+ATT BAR)
211004115	IP20 FRONT COVER
211004022	RC/PI TERM COVER
211004072	TEMWAY LINE TERM COVER
211004091	TEMWAY LOAD TERM COVER
4P FRAME SIZE	
211004075	F.C. TERM.COVER (NO ATT.BARS)
211004017	F.C. TERM.COVER (+ATT BARS)
211004023	RC/PI TERM COVER

Mechanical Interlocks

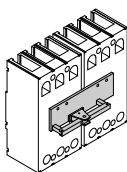

Item No	Description
3P FRAME SIZE	
211009003	FRONT MECHANICAL INTERLOCK
211009021	REAR MECHANICAL INTERLOCK
211009034	R MCH INTLK 1M WIRE
211009039	R MCH INTLK 1.5M WIRE
211009058	REAR MECH INTLK+ACC
211009136	REAR MECH I'LOCK+TEMTRANSFER
211009079	P/IN I'LOCK+ACCESSORIES
4P FRAME SIZE	
211009004	FRONT MECHANICAL INTERLOCK
211009022	REAR MECHANICAL INTERLOCK
211009034	R MCH INTLK 1M WIRE
211009039	R MCH INTLK 1.5M WIRE
211009044	P/IN I'LOCK+ACCESSORIES
211009059	REAR MECH INTLK+ACC
211009137	REAR MECH I'LOCK+TEMTRANSFER

Item No	Description
3P & 4P FRAME SIZE	
211010009	CASTELL A LOCK IN CLOSE
211010023	CASTELL B LOCK IN CLOSE
211010057	CASTELL A LOCK IN OPEN
211010068	CASTELL B LOCK IN OPEN
211010093	CASTELL SPEC LOCK IN OPEN
215010100	CASTELL LOCK XFH HANDLE
215010102	CAM FOR XFH HANDLE
212011003	HANDLE LOCK
211011013	ADJMNT SEALING FACILITY

Accessory Terminal Blocks



215006001	1 OFF ACCESSORY TERMINAL BLOCK
215006002	2 OFF ACCESSORY TERMINAL BLOCK
215006003	3 OFF ACCESSORY TERMINAL BLOCK
215006004	4 OFF ACCESSORY TERMINAL BLOCK

Handle Mechanisms

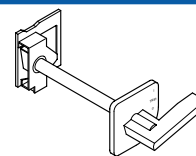

Item No	Description
211005178	ANTI-CL/WISE TAMPER PROOF HAND
211005172	CLOCKWISE TAMPER PROOF HANDLE
211005055	OHH ACW OFF OPEN LNG
211005027	OHH ACW OFF OPEN STD
211005041	OHH ACW RESET OPN LG
211005012	OHH ACW RESET OPEN STD
212005048	OHH CW OFF OPEN LONG
212005020	OHH C/W OFF OPEN STD
212005034	OHH CW RESET OPEN LG
212005005	OHH C/W RESET OPEN STD
211005226	OHJ:LEFT:BLACK HANDLE
211005234	OHJ:LEFT:BLACK:IP55 HANDLE
211005242	OHJ:LEFT:RED/YEL HANDLE
211005250	OHJ:LEFT:R/Y:IP55 HANDLE
211005194	OHJ:RIGHT:BLACK HANDLE
211005202	OHJ:RIGHT:BLACK:IP55 HANDLE
211005210	OHJ:RIGHT:RED/YEL HANDLE
211005218	OHJ:RHT:R/Y:IP55 HANDLE
211005258	OHJ:UPPER:BLACK HANDLE
211005266	OHJ:UPPER:BLACK:IP55 HANDLE
211005274	OHJ:UPPER:RED/YEL HANDLE
211005282	OHJ:UPPER:R/Y:IP55 HANDLE
211005155	OHE:HANDLE OPER MECHNSM.

Plug-In Bases

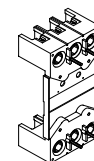

Item No	Description
3P FRAME SIZE	
211007067	IP20 PLUG IN BASE
211007020	IP20 PI+ATT BARS
211007037	PLUG IN BASE
211007010	PLUG IN+ATT BARS
211007109	PIB+R/ANGLE ATT BARS/400A/3P
215007049	5 BASE SIDE PLUG IN AUX CONN
4P FRAME SIZE	
211007068	IP20 PLUG IN BASE
211007139	PIB+IP20+ATTACH BARS/400A/4P
211007038	PLUG IN BASE
211007135	PIB+ATTACH BARS/400A/4P
215007049	5 BASE SIDE PLUG IN AUX CONN

Drawout Chassis

3P FRAME SIZE	
211014009	DRAW OUT CHASSIS/400AF/3P
211014012	D/O CHASSIS+POS SWITCH
4PFRAME SIZE	
211014015	DRAW OUT CHASSIS/400AF/4P
211014018	D/OCHASSIS+POS SWITCH



Catalogue Item Numbers

XE600NS, XS630CJ, XS630NJ, XS630SE-C, XS630SE, XH630SE, XS630NN

Moulded Case Circuit Breakers

Item No	Description	Item No	Description
205400550	XE600NS 500A 3P FC MCCB		
205400560	XE600NS 600A 3P FC MCCB		
205410540	XS630CJ 400A 3P FC MCCB	205410740	XS630CJ 400A 4P FC MCCB
205410563	XS630CJ 630A 3P FC MCCB	205410763	XS630CJ 630A 4P FC MCCB
205412540	XS630CJ 400A 3P FC GEN MCCB	205412740	XS630CJ 400A 4P FC GEN MCCB
205412563	XS630CJ 630A 3P FC GEN MCCB	205412763	XS630CJ 630A 4P FC GEN MCCB
205420540	XS630NJ 400A 3P FC MCCB	205420740	XS630NJ 400A 4P FC MCCB
205420563	XS630NJ 630A 3P FC MCCB	205420763	XS630NJ 630A 4P FC MCCB
205422540	XS630NJ 400A 3P FC GEN MCCB	205422740	XS630NJ 400A 4P FC GEN MCCB
205422563	XS630NJ 630A 3P FC GEN MCCB	205422763	XS630NJ 630A 4P FC GEN MCCB
205490563	XS630NN 630A 3P FC ISOLATOR	205490763	XS630NN 630A 4P FC ISOLATOR
205440563	XS630SE-C 630A 3P FC MCCB	205440763	XS630SE-C 630A 4P FC MCCB
205441563	XS630SE-C 630A & AI 3P FC MCCB	205441763	XS630SE-C 630A & AI 4P FC MCCB
205442563	XS630SE-C 630A & AP 3P FC MCCB	205442763	XS630SE-C 630A & AP 4P FC MCCB
205443563	XS630SE-C 630A & AH 3P FC MCCB	205443763	XS630SE-C 630A & AH 4P FC MCCB
205445563	XS630SE-C 630A & AG 3P FC MCCB	205445763	XS630SE-C 630A & AG 4P FC MCCB
205470563	XS630SE 630A 3P FC MCCB	205470763	XS630SE 630A 4P FC MCCB
205471563	XS630SE 630A & AI 3P FC MCCB	205471763	XS630SE 630A & AI 4P FC MCCB
205472563	XS630SE 630A & AP 3P FC MCCB	205472763	XS630SE 630A & AP 4P FC MCCB
205473563	XS630SE 630A & AH 3P FC MCCB	205473763	XS630SE 630A & AH 4P FC MCCB
205474563	XS630SE 630A & AG 3P FC MCCB	205474763	XS630SE 630A & AG 4P FC MCCB
205475563	XH630SE 630A 3P FC MCCB	205475763	XH630SE 630A 4P FC MCCB
205481563	XH630SE 630A & AI 3P FC MCCB	205481763	XH630SE 630A & AI 4P FC MCCB
205482563	XH630SE 630A & AP 3P FC MCCB	205482763	XH630SE 630A & AP 4P FC MCCB
205483563	XH630SE 630A & AH 3P FC MCCB	205483763	XH630SE 630A & AH 4P FC MCCB
205485563	XH630SE 630A & AG 3P FC MCCB	205485763	XH630SE 630A & AG 4P FC MCCB
205426540	XH630PJ 400A 3P FC MCCB	205426740	XH630PJ 400A 4P FC MCCB
205426563	XH630PJ 630A 3P FC MCCB	205426763	XH630PJ 630A 4P FC MCCB
205427563	XH630PE 630A 3P FC MCCB	205427763	XH630PE 630A 4P FC MCCB
205421563	XH630PE 630A & AI 3P FC MCCB	205421763	XH630PE 630A & AI 4P FC MCCB
205424563	XH630PE 630A & AH 3P FC MCCB	205424763	XH630PE 630A & AH 4P FC MCCB
205425563	XH630PE 630A & AG 3P FC MCCB	205425763	XH630PE 630A & AG 4P FC MCCB
205428563	XH630PE 630A & AP 3P FC MCCB	205428763	XH630PE 630A & AP 4P FC MCCB
XGA50-06	4TH NEUTRAL CT 630A		



Catalogue Item Numbers

XE600NS, XS630CJ, XS630NJ, XS630SE-C, XS630SE, XH630SE, XS630NN

Auxiliary Switches



Item No	Description
215001070	ALARM SWITCH
215001005	1AB AUXILIARY SWITCH
215001042	1AB AUX ALARM SWITCH
215001015	2AB AUXILIARY SWITCH
215001052	2AB AUX ALARM SWITCH
215001098	2AB AUX 2 ALARM SWITCH
215001025	3AB AUXILIARY SWITCH
215001097	3AB AUX 1 ALARM SWITCH

Undervoltage Trips



Item No	Description
215002067	UVT AC 100-120V
215002119	UVT AC 100-120V TIME DELAY
215002243	UVT AC 100-120V 1SEC TIME DEL
215002253	UVT AC 100-120V 2SEC TIME DEL
215002075	UVT AC 200-240V
215002127	UVT AC 200-240V TIME DELAY
215002206	UVT AC 200-240V 1SEC TIME DEL
215002215	UVT AC 200-240V 2SEC TIME DEL
215002313	UVT (IND) 240V
215002083	UVT AC 380-450V
215002135	UVT AC 380-450V TIME DELAY
215002226	UVT AC 380-450V 1SEC TIME DEL
215002235	UVT AC 380-450V 2SEC TIME DEL
215002101	UVT DC 100-115V
215002111	UVT DC 200-230V
215002093	UVT DC 24V
215002173	UVT DC 48V
215002181	UVT DC 60V

Shunt Trips



Item No	Description
215002006	SHUNT AC 100-115V
215002014	SHUNT AC 200-480V
215002024	SHUNT DC 12V
215002032	SHUNT DC 24V
215002040	SHUNT DC 48V
215002051	SHUNT DC 100-115V
215002059	SHUNT DC 200-230V
215002146	SHUNT AC 24V
215002156	SHUNT AC 48V
215002164	SHUNT DC 60V
215002198	SHUNT DC 125V
215002190	SHUNT DC 30V

Connections

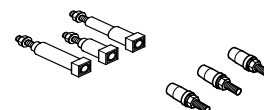

630A 3P FRAME SIZE	
215003243	D/O CONNECTION
215003103	FC LINE/RC LOAD CONNECTIONS
215003192	1/2 SET SOLDERLESS TERMINAL
215003141	IP20 PLUG IN CONNECTIONS
215003058	PLUG IN CONNECTIONS
215003216	REAR CONNECTIONS
215003115	RC LINE/FC LOAD CONNECTIONS
215003019	SOLDERLESS TERMINAL
215003034	REAR CONNECTIONS
215003104	FC LINE/RC LOAD CONNECTIONS
215003127	TEMWAY CONNECTION POSTS
215003072	5 MCCB SIDE PLUG IN AUX CONN

630A 4P FRAME SIZE	
215003247	D/O CONNECTION
215003104	FC LINE/RC LOAD CONNECTIONS
215003193	1/2 SET SOLDERLESS TERMINALS
215003142	IP20 PLUG IN CONNECTIONS
215003059	PLUG IN CONNECTIONS
215003034	REAR CONNECTIONS
215003116	RC LINE/FC LOAD CONNECTIONS
215003020	SOLDERLESS TERMINAL
215003034	REAR CONNECTIONS
215003104	FC LINE/RC LOAD CONNECTIONS
215003072	5 MCCB SIDE PLUG IN AUX CONN

Motor Operators

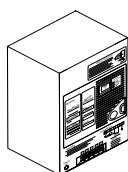

Item No	Description
215008016	MOTOR AC 100-110V
215008024	MOTOR AC 200-220V
215008043	MOTOR AC 240V
215008054	MOTOR DC 24V
215008057	MOTOR DC 110V

Mechanical Interlocks

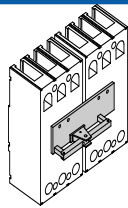

Item No	Description
3P FRAME SIZE	
215009005	FRONT MECHANICAL INTERLOCK
215009023	REAR MECHANICAL INTERLOCK
215009035	R MCH INTLK 1M WIRE
215009040	R MCH INTLK 1.5M WIRE
215009060	REAR MECH INTLK+ACC
215009138	REAR MECH I'LOCK+TEMTRANSFER
215009080	P/IN I'LOCK+ACCESSORIES
4P FRAME SIZE	
215009006	FRONT MECHANICAL INTERLOCK
215009024	REAR MECHANICAL INTERLOCK
215009035	R MCH INTLK 1M WIRE
215009040	R MCH INTLK 1.5M WIRE
215009045	P/IN I'LOCK+ACCESSORIES
215009061	REAR MECH INTLK+ACC
215009139	REAR MECH I'LOCK+TEMTRANSFER
3P & 4P FRAME SIZE	
215010010	CASTELL A OPEN TRAP
215010024	CASTELL B OPEN TRAP
215010047	CASTELL SPEC OPEN TRAP
215010058	CASTELL A CLOSE TRAP
215010069	CASTELL B CLOSE TRAP
215010094	CASTELL SPEC CLOSE TRAP
215010100	CASTELL LOCK XFH HANDLE
215010102	CAM FOR XFH HANDLE
215010107	CASTELL LCK XFH SP HANDLE
215011004	HANDLE LOCK
215011007	HANDLE EXTENSION
215011014	ADJMNT SEALING FACILITY

Handle Mechanisms

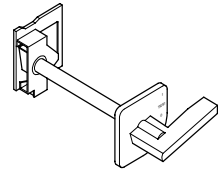

Item No	Description
215005179	ANTI-CL/WISE TAMPERPROOF HAND
215005173	CLOCKWISE TAMPERPROOF HANDLE
215005056	OHH ACW : OFF OPEN LONG
215005028	OHH ACW : OFF OPEN STD
215005042	OHH ACW : RESET OPEN LONG
215005013	OHH ACW : RESET OPEN STD
215005049	OHH CW OFF OPEN LONG
215005021	OHH C/W OFF OPEN STD
215005035	OHH CW RESET OPEN LG
215005006	OHH C/W RESET OPEN STD
215005227	TFJ:LEFT:BLACK HANDLE
215005235	TFJ:LEFT:BLACK:IP55 HANDLE
215005243	TFJ:LEFT:RED/YEL HANDLE
215005251	TFJ:LEFT:RED/YEL HANDLE
215005195	TFJ:RIGHT:BLACK HANDLE
215005203	TFJ:RIGHT:BLACK: IP55 HANDLE
215005211	TFJ:RIGHT:RED/YEL HANDLE
215005219	TFJ:RIGHT:RED/YEL:IP55 HANDLE
215005259	TFJ:UPPER:BLACK HANDLE
215005267	TFJ:UPPER:BLACK:IP55 HANDLE
215005275	TFJ:UPPER:RED/YEL HANDLE
215005283	TFJ:UPPER:RED/YEL:IP55 HANDLE
215005156	OHE:HANDLE OPER MECHNSM.

Plug-In Bases

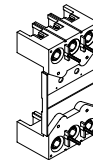

3P FRAME SIZE	
215007069	IP20 BASE/ PI MCCB
215007021	IP20 PI+ATT BARS
215007039	PLUG IN BASE
215007011	PLUG IN+ATT BARS
215007110	PIB+R/ANGLE ATT BARS/800A/3P
215007049	5 BASE SIDE PLUG IN AUX CONN
4P FRAME SIZE	
215007070	IP20 BASE/ PI MCCB
215007140	PIB+IP20+ATTACH BARS/800A/4P
215007040	PLUG IN BASE
215007136	PIB+ATTACH BARS/800A/4P
215007049	5 BASE SIDE PLUG IN AUX CONN



Catalogue Item Numbers

XE600NS, XS630CJ, XS630NJ, XS630SE-C, XS630SE, XH630SE, XS630NN

Drawout Chassis

Item No	Description
3P FRAME SIZE	
215014036	DRAW OUT CHASSIS
215014041	D/O CHASSIS+POS SWITCH
4P FRAME SIZE	
215014045	DRAW OUT CHASSIS
215014049	D/O CHASSIS+POS SWITCH

Terminal Covers

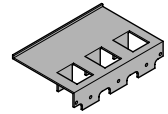
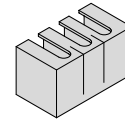

Item No	Description
3P FRAME SIZE	
215004018	F.C. TERMINAL COVER
215004042	1/2 SET INT/POLE BARRIER
215004050	FULL SET I/POLE BARRIER
215004139	IP20 TERMINAL COVER
215004180	IP40 RC/PI TERM COVER
215004024	RC/PI TERM COVER
215004073	TEMWAY LINE TERM COVER
215004092	TEMWAY LOAD TERM COVER
4P FRAME SIZE	
215004019	F.C. TERMINAL COVER
215004069	1/2 SET TERMINAL COVERS
215004043	1/2 SET INT/POLE BARRIER
215004051	FULL SET I/POLE BARRIER
215004025	RC/PI TERM COVER
215004025	RC/PI TERM COVER

Accessory Terminal Covers

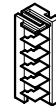

215006001	1 OFF ACCESSORY TERMINAL BLOCK
215006002	2 OFF ACCESSORY TERMINAL BLOCK
215006003	3 OFF ACCESSORY TERMINAL BLOCK
215006004	4 OFF ACCESSORY TERMINAL BLOCK



Catalogue Item Numbers

XS800NJ, XH800PS, XS800SE, XH800SE, XS800NN, XS1000ND

Moulded Case Circuit Breakers

Item No	Description	Item No	Description
205520580	XS800NJ 800A 3P FC MCCB	205520780	XS800NJ 800A 4P FC MCCB
205522580	XS800NJ 800A 3P FC GEN MCCB	205522780	XS800NJ 800A 4P FC GEN MCCB
205590580	XS800NN 800A 3P FC ISOLATOR	205590780	XS800NN 800A 4P FC ISOLATOR
205595570	XH800PS 700A 3P FC MCCB	205595770	XH800PS 700A 4P FC MCCB
205595580	XH800PS 800A 3P FC MCCB	205595780	XH800PS 800A 4P FC MCCB
205570580	XS800SE 800A 3P FC MCCB	205570780	XS800SE 800A 4P FC MCCB
205571580	XS800SE 800A & AI 3P FC MCCB	205571780	XS800SE 800A & AI 4P FC MCCB
205572580	XS800SE 800A & AP 3P FC MCCB	205572780	XS800SE 800A & AP 4P FC MCCB
205575580	XS800SE 800A & AG 3P FC MCCB	205575780	XS800SE 800A & AG 4P FC MCCB
205576580	XH800SE 800A 3P FC MCCB	205576780	XH800SE 800A 4P FC MCCB
205581580	XH800SE 800A & AI 3P FC MCCB	205581780	XH800SE 800A & AI 4P FC MCCB
205582580	XH800SE 800A & AP 3P FC MCCB	205582780	XH800SE 800A & AP 4P FC MCCB
205585580	XH800SE 800A & AG 3P FC MCCB	205585780	XH800SE 800A & AG 4P FC MCCB
204640510	XS1000ND 3P FC MCCB		
XGA50-08	4TH NEUTRAL CT 800A		

Auxiliary Switches



Item No	Description
215001070	ALARM SWITCH
215001005	1AB AUXILIARY SWITCH
215001042	1AB AUX ALARM SWITCH
215001015	2AB AUXILIARY SWITCH
215001052	2AB AUX ALARM SWITCH
215001098	2AB AUX 2 ALARM SWITCH
215001025	3AB AUXILIARY SWITCH
215001097	3AB AUX 1 ALARM SWITCH

Undervoltage Trips

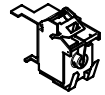

Item No	Description
* 215002067	UVT AC 100-120V
* 215002119	UVT AC 100-120V TIME DELAY
* 215002243	UVT AC 100-120V 1SEC TIME DEL
* 215002253	UVT AC 100-120V 2SEC TIME DEL
* 215002075	UVT AC 200-240V
* 215002127	UVT AC 200-240V TIME DELAY
* 215002206	UVT AC 200-240V 1SEC TIME DELAY
* 215002215	UVT AC 200-240V 2SEC TIME DEL
* 215002313	UVT (IND) 240V
* 215002083	UVT AC 380-450V
* 215002135	UVT AC 380-450V TIME DELAY
* 215002226	UVT AC 380-450V 1SEC TIME DEL
* 215002235	UVT AC 380-450V 2SEC TIME DEL
215002101	UVT DC 100-115V
215002111	UVT DC 200-230V
215002093	UVT DC 24V
* 215002173	UVT DC 48V
* 215002181	UVT DC 60V

Shunt Trips



215002006	SHUNT AC 100-115V
215002014	SHUNT AC 200-480V
215002024	SHUNT DC 12V
215002032	SHUNT DC 24V
215002040	SHUNT DC 48V
215002051	SHUNT DC 100-115V
215002059	SHUNT DC 200-230V
215002146	SHUNT AC 24V
215002156	SHUNT AC 48V
215002164	SHUNT DC 60V
215002198	SHUNT DC 125V
215002190	SHUNT DC 30V

Connections

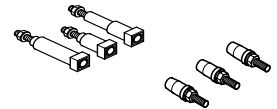

800A 3P FRAME SIZE

215003251	D/O CONNECTION
215003103	FC LINE/RC LOAD CONNECTIONS
215003192	1/2 SET SOLDERLESS TERMINAL
215003143	IP20 PLUG IN CONNECTIONS
215003060	PLUG IN CONNECTIONS
215003216	REAR CONNECTIONS
215003115	RC LINE/FC LOAD CONNECTIONS
215003019	SOLDERLESS TERMINAL
215003034	REAR CONNECTIONS
215003104	FC LINE/RC LOAD CONNECTIONS
215003127	TEMWAY CONNECTION POSTS
215003072	5 MCCB SIDE PLUG IN AUX CONN

800A 4P FRAME SIZE

215003256	D/O CONNECTION
215003104	FC LINE/RC LOAD CONNECTIONS
215003193	1/2 SET SOLDERLESS TERMINALS
215003144	IP20 PLUG IN CONNECTIONS
215003061	PLUG IN CONNECTIONS
215003034	REAR CONNECTIONS
215003116	RC LINE/FC LOAD CONNECTIONS
215003020	SOLDERLESS TERMINAL
215003034	REAR CONNECTIONS
215003104	FC LINE/RC LOAD CONNECTIONS
215003072	5 MCCB SIDE PLUG IN AUX CONN

Motor Operators

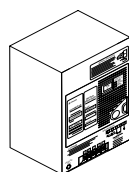

215008016	MOTOR AC 100-110V
215008024	MOTOR AC 200-220V
215008043	MOTOR AC 240V
215008054	MOTOR DC 24V
215008057	MOTOR DC 110V

* Not available for XS1000ND



Catalogue Item Numbers

XS800NJ, XH800PS, XS800SE, XH800SE, XS800NN, XS1000ND

Mechanical Interlocks

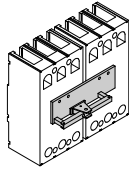

Item No	Description
3P FRAME SIZE	
215009005	FRONT MECHANICAL INTERLOCK
215009023	REAR MECHANICAL INTERLOCK
215009035	R MCH INTLK 1M WIRE
215009040	R MCH INTLK 1.5M WIRE
215009060	REAR MECH INTLK+ACC
215009138	REAR MECH I'LOCK+TEMTRANSFER
215009080	P/IN I'LOCK+ACCESSORIES
4P FRAME SIZE	
215009006	FRONT MECHANICAL INTERLOCK
215009024	REAR MECHANICAL INTERLOCK
215009035	R MCH INTLK 1M WIRE
215009040	R MCH INTLK 1.5M WIRE
215009045	P/IN I'LOCK+ACCESSORIES
215009061	REAR MECH INTLK+ACC
215009139	REAR MECH I'LOCK+TEMTRANSFER
3P & 4P FRAME SIZE	
215010010	CASTELL A OPEN TRAP
215010024	CASTELL B OPEN TRAP
215010047	CASTELL SPEC OPEN TRAP
215010058	CASTELL A CLOSE TRAP
215010069	CASTELL B CLOSE TRAP
215010094	CASTELL SPEC CLOSE TRAP
215010100	CASTELL LOCK XFH HANDLE
215010102	CAM FOR XFH HANDLE
215010107	CASTELL LCK XFH SP HANDLE
215011004	HANDLE LOCK
215011007	HANDLE EXTENSION
215011014	ADJMNT SEALING FACILITY

Handle Mechanisms

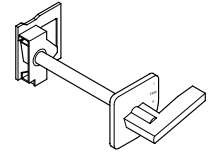

Item No	Description
215005179	ANTI-CL/WISE TAMPERPROOF HAND
215005173	CLOCKWISE TAMPERPROOF HANDLE
215005056	OHH ACW : OFF OPEN LONG
215005028	OHH ACW : OFF OPEN STD
215005042	OHH ACW : RESET OPEN LONG
215005013	OHH ACW : RESET OPEN STD
215005049	OHH CW OFF OPEN LONG
215005021	OHH C/W OFF OPEN STD
215005035	OHH CW RESET OPEN LG
215005006	OHH C/W RESET OPEN STD
215005227	TFJ:LEFT:BLACK HANDLE
215005235	TFJ:LEFT:BLACK:IP55 HANDLE
215005243	TFJ:LEFT:RED/YEL HANDLE
215005251	TFJ:LEFT:RED/YEL HANDLE
215005195	TFJ:RIGHT:BLACK HANDLE
215005203	TFJ:RIGHT:BLACK: IP55 HANDLE
215005211	TFJ:RIGHT:RED/YEL HANDLE
215005219	TFJ:RIGHT:RED/YEL:IP55 HANDLE
215005259	TFJ:UPPER:BLACK HANDLE
215005267	TFJ:UPPER:BLACK:IP55 HANDLE
215005275	TFJ:UPPER:RED/YEL HANDLE
215005283	TFJ:UPPER:RED/YEL:IP55 HANDLE
215005156	OHE:HANDLE OPER MECHNSM.

Plug-In Bases

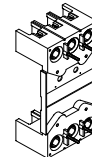

3P FRAME SIZE	
215007069	IP20 BASE/ PI MCCB
215007021	IP20 PI+ATT BARS
215007039	PLUG IN BASE
215007011	PLUG IN+ATT BARS
215007110	PIB+R/ANGLE ATT BARS/800A/3P
215007049	5 BASE SIDE PLUG IN AUX CONN
4P FRAME SIZE	
215007070	IP20 BASE/ PI MCCB
215007140	PIB+IP20+ATTACH BARS/800A/4P
215007040	PLUG IN BASE
215007136	PIB+ATTACH BARS/800A/4P
215007049	5 BASE SIDE PLUG IN AUX CONN



Catalogue Item Numbers

XS800NJ, XH800PS, XS800SE, XS800NN, XS1000ND

Drawout Chassis

Item No	Description
3P FRAME SIZE	
215014036	3P FRAME SIZE DRAW OUT CHASSIS
215014041	D/O CHASSIS+POS SWITCH
215004050	FULL SET I/POLE BARRIER
4P FRAME SIZE	
215014045	DRAW OUT CHASSIS
215014049	D/O CHASSIS+POS SWITCH
215004073	TEMWAY LINE TERM COVER
215004092	TEMWAY LOAD TERM COVER

Terminal Covers

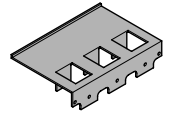
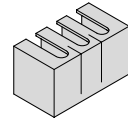

Item No	Description
215004018	F.C. TERMINAL COVER
215004042	1/2 SET INT/POLE BARRIER
215004139	IP20 TERMINAL COVER
215004180	IP40 RC/PI TERM COVER
215004024	RC/PI TERM COVER
4P FRAME SIZE	
215004019	F.C. TERMINAL COVER
215004069	1/2 SET TERMINAL COVERS
215004043	1/2 SET INT/POLE BARRIER
215004051	FULL SET I/POLE BARRIER
215004025	RC/PI TERM COVER
215004025	RC/PI TERM COVER

Accessory Terminal Covers



215006001	1 OFF ACCESSORY TERMINAL BLOCK
215006002	2 OFF ACCESSORY TERMINAL BLOCK
215006003	3 OFF ACCESSORY TERMINAL BLOCK
215006004	4 OFF ACCESSORY TERMINAL BLOCK



Catalogue Item Numbers

XS1250SE, XS1250ND, XS1250NN, XS1600SE, XS1600ND, XS1600NN

Moulded Case Circuit Breakers

Item No	Description	Item No	Description
204690512	XS1250NN 1250A 3P FC ISOLATOR	204690712	XS1250NN 1250A 4P FC ISOLATOR
204645512	XS1250ND 3P FC MCCB		
204670510	XS1250SE 1000A 3P FC MCCB	204670710	XS1250SE 1000A 4P FC MCCB
204670512	XS1250SE 1250A 3P FC MCCB	204670712	XS1250SE 1250A 4P FC MCCB
204671510	XS1250SE 1000A & AI 3P FC MCCB	204671710	XS1250SE 1000A &AI 4P FC MCCB
204671512	XS1250SE 1250A & AI 3P FC MCCB	204671712	XS1250SE 1250A &AI 4P FC MCCB
204672510	XS1250SE 1000A & AP 3P FC MCCB	204672710	XS1250SE 1000A & AP 4P FC MCCB
204672512	XS1250SE 1250A & AP 3P FC MCCB	204672712	XS1250SE 1250A & AP 4P FC MCCB
204675510	XS1250SE 1000A & AG 3P FC MCCB	204675710	XS1250SE 1000A & AG 4P FC MCCB
204675512	XS1250SE 1250A & AG 3P FC MCCB	204675712	XS1250SE 1250A & AG 4P FC MCCB
204790516	XS1600NN 1600A 3P FC ISOLATOR	204790716	XS1600NN 1600A 4P FC ISOLATOR
204790616	XS1600NN 1600A 3P RC ISOLATOR	204790816	XS1600NN 1600A 4P RC ISOLATOR
204790916	XS1600NN 1600A 3P DRAWOUT	204790016	XS1600NN 1600A 4P DRAWOUT
204770516	XS1600ND 1600A 3P FC MCCB		
204790516	XS1600SE1600A 3P FC MCCB	204770716	XS1600SE 1600A 4P FC MCCB
204790516	XS1600SE 1600A &A1 3P FC MCCB	204771716	XS1600SE 1600A&AI 4P FC MCCB
204772516	XS1600SE 1600A &AP 3P FC MCCB	204772716	XS1600SE 1600A&AP 4P FC MCCB
204790516	XS1600SE 1600A &AG 3P FC MCCB	204775716	XS1600SE 1600A&AG 4P FC MCCB
XGA85-10	4TH NEUTRAL CT 1000A		
XGA85-12	4TH NEUTRAL CT 1250A		
XGA85-16	4TH NEUTRAL CT 1600A		



Catalogue Item Numbers

XS1250SE, XS1250ND, XS1250NN, XS1600SE, XS1600ND, XS1600NN

Auxiliary Switches



Item No	Description
3P FRAME SIZE	
212001071	ALARM SWITCH
212001006	1AB AUXILIARY SWITCH
212001043	1AB AUX ALARM SWITCH
212001016	2AB AUXILIARY SWITCH
212001053	2AB AUX ALARM SWITCH
212001102	2AB AUX 2 ALARM SWITCH
212001026	3AB AUXILIARY SWITCH
212001101	3AB AUX 1 ALARM SWITCH
3P FRAME SIZE	
212001072	ALARM SWITCH
211001007	1AB AUXILIARY SWITCH
212001044	1AB AUX ALARM SWITCH
212001017	2AB AUXILIARY SWITCH
212001054	2AB AUX ALARM SWITCH
212001104	2AB AUX 2 ALARM SWITCH
212001027	3AB AUXILIARY SWITCH
212001103	3AB AUX 1 ALARM SWITCH

Undervoltage Trips



Item No	Description
* 212002068	UVT AC 100-120V
* 212002120	UVT AC 100-120V TIME DELAY
* 211002244	UVT AC 100-120V 1SEC TIME DEL
* 211002254	UVT AC 100-120V 2SEC TIME DEL
* 212002076	UVT AC 200-240V
* 212002128	UVT AC 200-240V TIME DELAY
* 212002208	UVT AC 200-240V 1SEC TIME DEL
* 211002216	UVT AC 200-240V 2SEC TIME DEL
* 211002314	UVT (IND) 240V
* 211002084	UVT AC 380-450V
* 212002136	UVT AC 380-450V TIME DELAY
* 211002228	UVT AC 380-450V 1SEC TIME DEL
* 211002236	UVT AC 380-450V 2SEC TIME DEL
212002102	UVT DC 100-115V
212002112	UVT DC 200-230V
212002094	UVT DC 24V
* 212002174	UVT DC 48V
* 212002183	UVT DC 60V

Shunt Trips



212002007	SHUNT AC 100-115V
212002015	SHUNT AC 200-480V
211002147	SHUNT AC 24V
211002157	SHUNT AC 48V
212002052	SHUNT DC 100-115V
211002025	SHUNT DC 12V
212002199	SHUNT DC 125V
212002060	SHUNT DC 200-230V
212002033	SHUNT DC 24V
212002191	SHUNT DC 30V
212002041	SHUNT DC 48V
211002165	SHUNT DC 60V

Connections

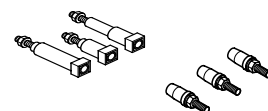

1250A 3P FRAME SIZE	
212003260	D/O CONNECTION
211003099	FC LINE/RC LOAD CONNECTIONS
212003145	IP20 PLUG IN CONNECTIONS
212003062	PLUG IN CONNECTIONS
212003025	REAR CONNECTIONS
211003110	RC LINE/FC LOAD CONNECTIONS
212003026	REAR CONNECTIONS
212003100	FC LINE/RC LOAD CONNECTIONS
215003072	5 MCCB SIDE PLUG IN AUX CONN

1250A 4P FRAME SIZE	
212003264	D/O CONNECTION
212003100	FC LINE/RC LOAD CONNECTIONS
212003146	IP20 PLUG IN CONNECTIONS
212003063	PLUG IN CONNECTIONS
212003026	REAR CONNECTIONS
212003111	RC LINE/FC LOAD CONNECTIONS
212003026	REAR CONNECTIONS
212003100	FC LINE/RC LOAD CONNECTIONS
215003072	5 MCCB SIDE PLUG IN AUX CONN

1600A 3P FRAME SIZE	
212003212	FC LINE/RC LOAD CONNECTIONS
212003112	RC LINE/FC LOAD CONNECTIONS

1600A 4P FRAME SIZE	
211003307	REAR CONNECTIONS

Motor Operators

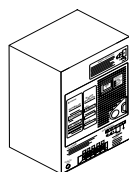

211008074	XMD MOTOR AC100-115V
211008075	XMD MOTOR AC200-230V
211008076	XMD MOTOR DC 24V
211008077	XMD MOTOR DC100-110V
212008044	MOTOR AC 240V

* Not available for XS1250ND, XS1600ND

Terminal Covers

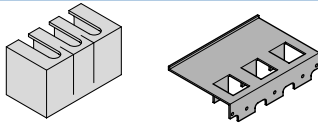

Item No	Description
1250A 3P FRAME SIZE	
211004020	F.C. TERMINAL COVER
211004070	1/2 SET TERMINAL COVERS
1250A4P FRAME SIZE	
211004021	F.C. TERMINAL COVER
211004071	1/2 SET TERMINAL COVERS

Handle Mechanisms

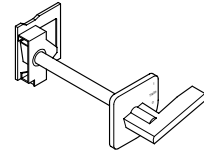

Item No	Description
211005181	ANTI-CL/WISE TAMPER PROOF HAND
211005174	CLOCKWISE TAMPER PROOF HANDLE
211005057	OHH ACW OFF OPEN LNG
211005029	OHH ACW OFF OPEN STD
211005043	OHH ACW RESET OPN LG
211005014	OHH ACW RESET OPEN STD
212005050	OHH CW OFF OPEN LONG
212005022	OHH C/W OFF OPEN STD
212005036	OHH CW RESET OPEN LG
212005007	OHH C/W RESET OPEN STD
211005228	OHJ:LEFT:BLACK HANDLE
211005236	OHJ:LEFT:BLACK:IP55 HANDLE
211005244	OHJ:LEFT:RED/YEL HANDLE
211005252	OHJ:LEFT:R/Y:IP55 HANDLE
211005196	OHJ:RIGHT:BLACK HANDLE
211005204	OHJ:RIGHT:BLACK:IP55 HANDLE
211005212	OHJ:RIGHT:RED/YEL HANDLE
211005220	OHJ:RHT:R/Y:IP55 HANDLE
211005260	OHJ:UPPER:BLACK HANDLE
211005268	OHJ:UPPER:BLACK:IP55 HANDLE
211005276	OHJ:UPPER:RED/YEL HANDLE
211005284	OHJ:UPPER:R/Y:IP55 HANDLE
211005157	OHE:HANDLE OPER MECHNSM.

Plug-In Bases

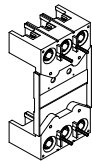

3P FRAME SIZE	
211007071	IP20 PLUG IN BASE
211007041	PLUG IN BASE
215007049	5 BASE SIDE PLUG IN AUX CONN
4P FRAME SIZE	
211007072	IP20 PLUG IN BASE
211007042	PLUG IN BASE
215007049	5 BASE SIDE PLUG IN AUX CONN

Drawout Chassis

1250A 3P FRAME SIZE	
211014053	DRAW OUT CHASSIS
211014057	D/O CHASSIS+POS SWITCH
1250A 4P FRAME SIZE	
211014061	DRAW OUT CHASSIS
211014065	D/O CHASSIS+POS SWITCH

Accessory Terminal Blocks

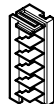

215006001	1 OFF ACCESSORY TERMINAL BLOCK
215006002	2 OFF ACCESSORY TERMINAL BLOCK
215006003	3 OFF ACCESSORY TERMINAL BLOCK
215006004	4 OFF ACCESSORY TERMINAL BLOCK



Catalogue Item Numbers

XS1250SE, XS1250ND, XS1250NN, XS1600SE, XS1600ND, XS1600NN

Mechanical Interlocks

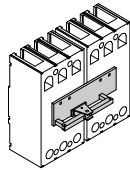

Item No	Description
1250A 3P FRAME SIZE	
211009007	FRONT MECHANICAL INTERLOCK
211009025	REAR MECHANICAL INTERLOCK
211009028	REAR MECH INTLK+ACC
211009036	R MCH INTLK 1M WIRE
211009041	R MCH INTLK 1.5M WIRE
1250A 4P FRAME SIZE	
211009008	FRONT MECHANICAL INTERLOCK
211009026	REAR MECHANICAL INTERLOCK
211009029	REAR MECH INTLK+ACC
211009141	REAR MECH I'LOCK+TEMTRANSFER
211009036	R MCH INTLK 1M WIRE
211009041	R MCH INTLK 1.5M WIRE
211009082	P/IN I'LOCK+ACCESSORIES
1600A 3P FRAME SIZE	
211009007	FRONT MECHANICAL INTERLOCK
211009027	REAR MECHANICAL INTERLOCK
211009030	REAR MECH INTLK+ACC
211009033	R MCH INTLK+TMTRC
211009037	R MCH INTLK 1M WIRE
211009042	R MCH INTLK 1.5M WIRE
211009142	REAR MECH I'LOCK+TEMTRANSFER
1600A 4P FRAME SIZE	
211009008	FRONT MECHANICAL INTERLOCK
211009037	R MCH INTLK 1M WIRE
211009042	R MCH INTLK 1.5M WIRE
211009087	REAR MECHANICAL INTERLOCK
3P & 4P FRAME SIZE	
211010013	CASTELL A LOCK IN CLOSE
211010025	CASTELL B LOCK IN CLOSE
211010059	CASTELL A LOCK IN OPEN
211010070	CASTELL B LOCK IN OPEN
215010100	CASTELL LOCK XFH HANDLE
215010102	CAM FOR XFH HANDLE
215010107	CASTELL LCK XFH SP HANDLE
211011005	HANDLE LOCK
215011007	HANDLE EXTENSION
211011015	ADJMNT SEALING FACILITY
211010048	CASTELL SPEC LOCK IN CLOSE
211010097	CASTELL SPEC LOCK IN OPEN



Moulded Case Circuit Breakers

Item No	Description	Item No	Description
204840520	XS2000ND 3P FC MCCB	204850720	XS2000NE 2000A 4P FC MCCB
204840620	XS2000ND 3P RC MCCB	204850820	XS2000NE 2000A 4P RC MCCB
204850520	XS2000NE 2000A 3P FC MCCB	204851720	XS2000NE 2000A &AI 4P FC MCCB
204850620	XS2000NE 2000A 3P RC MCCB	204851820	XS2000NE 2000A &AI 4P RC MCCB
204851520	XS2000NE 2000A &AI 3P FC MCCB	204852720	XS2000NE 2000A &AP 4P FC MCCB
204851620	XS2000NE 2000A &AI 3P RC MCCB	204852820	XS2000NE 2000A &AP 4P RC MCCB
204852520	XS2000NE 2000A &AP 3P FC MCCB	204853720	XS2000NE 2000A &AH 4P FC MCCB
204852620	XS2000NE 2000A &AP 3P RC MCCB	204853820	XS2000NE 2000A &AI 4P RC MCCB
204853520	XS2000NE 2000A &AH 3P FC MCCB	204854720	XS2000NE 2000A&AH&AP 4PFC MCCB
204853620	XS2000NE 2000A &AI 3P RC MCCB	204854820	XS2000NE 2000A AI&AP4P RC MCCB
204854520	XS2000NE 2000A&AH&AP 3PFC MCCB	204855720	XS2000NE 2000A &AG 4P FC MCCB
204854620	XS2000NE 2000A&AH&AP3P RC MCCB	204855820	XS2000NE 2000A &AG 4P RC MCCB
204855520	XS2000NE 2000A &AG 3P FC MCCB		
204855620	XS2000NE 2000A &AG 3P RC MCCB		
204940625	XS2500ND 3P RC MCCB	204950825	XS2500NE 2500A 4P RC MCCB
204950625	XS2500NE 2500A 3P RC MCCB	204951825	XS2500NE 2500A &AI 4P RC MCCB
204951625	XS2500NE 2500A &AI 3P RC MCCB	204952825	XS2500NE 2500A &AP 4P RC MCCB
204952625	XS2500NE 2500A &AP 3P RC MCCB	204953825	XS2500NE 2500A &AH 4P RC MCCB
204953625	XS2500NE 2500A &AH 3P RC MCCB	204955825	XS2500NE 2500A &AG 4P RC MCCB
204955625	XS2500NE 2500A &AG 3P RC MCCB		
204890520	XS2000NN 2000A 3P FC ISOLATOR	204990625	XS2500NN 2500A 3P RC ISOLATOR
204890620	XS2000NN 2000A 3P RC ISOLATOR	204990825	XS2500NN 2500A 4P RC ISOLATOR
204890720	XS2000NN 2000A 4P FC ISOLATOR		
204890820	XS2000NN 2000A 4P RC ISOLATOR		
XGA85-20	4TH NEUTRAL CT 2000A		

Auxiliary Switches



212001010	1AB AUXILIARY SWITCH
212001020	2AB AUXILIARY SWITCH
212001030	3AB AUXILIARY SWITCH
212001031	4AB AUXILIARY SWITCH
212001035	5AB AUXILIARY SWITCH
212001036	6AB AUXILIARY SWITCH
212001047	1AB AUX ALARM SWITCH
212001057	2AB AUX ALARM SWITCH
212001063	3AB AUX ALARM SWITCH
212001064	4AB AUX ALARM SWITCH
212001065	5AB AUX ALARM SWITCH
212001075	ALARM SWITCH



Shunt Trips

211002008	SHUNT AC 100-115V
211002016	SHT AC 200/240V(XS2000/2500NE)
211002017	SHT AC 380/450V(XS2000/2500NE)
211002026	SHUNT DC 12V
212002034	SHUNT DC 24V
211002042	SHUNT DC 48V
211002053	SHUNT DC 100-115V
211002061	SHUNT DC 200-230V
212002148	SHUNT AC 24V
212002158	SHUNT AC 48V
212002166	SHUNT DC 60V

Undervoltage Trips

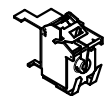

* 212002069	UVT AC 100-120V
* 211002077	UVT AC 200-240V
* 211002085	UVT AC 380-450V
* 211002095	UVT DC 24V
* 212002103	UVT DC 100-115V
* 212002113	UVT DC 200-230V
* 211002121	UVT AC 100-120V TIME DELAY
* 211002129	UVT AC 200-240V TIME DELAY
* 211002137	UVT AC 380-450V TIME DELAY
* 212002208	UVT AC 200-240V 1SEC TIME DEL
* 212002217	UVT AC 200-240V 2SEC TIME DEL
* 212002229	UVT AC 380-450V 1SEC TIME DEL
* 212002237	UVT AC 380-450V 2SEC TIME DEL
* 212002245	UVT AC 100-120V 1SEC TIME DEL
* 212002255	UVT AC 100-120V 2SEC TIME DEL
* 212002175	UVT DC 48V
* 212002184	UVT DC 60V
* 211002315	UVT (IND) 240V

Motor Operators

211008018	MOTOR AC 100-110V
211008026	MOTOR AC 200-220V
211008103	XMB3-C MOTOR AC 440V

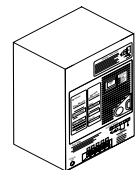

* Not available for XS2000ND, XS2500ND



Catalogue Item Numbers

XS2000NE, XS2000ND, XS2500NE, XS2500ND

Mechanical Interlock

211002192

SHUNT DC 30V

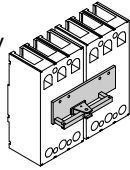

Item No

Description

3P FRAME SIZE

211009012	FRONT MECHANICAL INTERLOCK
211009038	R MCH INTLK 1M WIRE
211009043	R MCH INTLK 1.5M WIRE
211009116	REAR MECH.INTERLOCK

4P FRAME SIZE

211009013	FRONT MECHANICAL INTERLOCK
211009038	R MCH INTLK 1M WIRE
211009043	R MCH INTLK 1.5M WIRE
211009117	REAR MECH.INTERLOCK

3P & 4P FRAME SIZES

211009038	R MCH INTLK 1M WIRE
211009043	R MCH INTLK 1.5M WIRE
211010014	CASTELL A LOCK IN CLOSE
211010026	CASTELL B LOCK IN CLOSE
211010049	CASTELL SPEC LOCK IN CLOSE
211010060	CASTELL A LOCK IN OPEN
211010071	CASTELL B LOCK IN OPEN
211010098	CASTELL SPEC LOCK IN OPEN
211011006	HANDLE LOCK
211011016	ADJMNT SEALING FACILITY

Handle Mechanisms

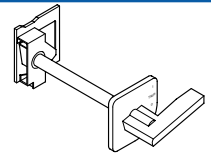

Item No

Description

211005158	OHE:HANDLE OPER MECHNSM.
211005162	DOOR FLANGE

Accessory Terminal Blocks

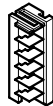

215006001	1 OFF ACCESSORY TERMINAL BLOCK
215006002	2 OFF ACCESSORY TERMINAL BLOCK
215006003	3 OFF ACCESSORY TERMINAL BLOCK
215006004	4 OFF ACCESSORY TERMINAL BLOCK



Earth Leakage Relays, Toroidal CTs and Multimeters

Item No	Description	Item No	Description
601101001	ELRC-1/35/24~48 V AC/DC	631030100	RFC-3
601101003	ELRC-1/35/110/240/415 V AC	631040100	RFC-4
601102001	ELRC-1/60/24~48 V AC/DC	631040110	RFC-4B
601102003	ELRC-1/60/110/240/415 V AC	631040200	RFCA
601103001	ELRC-1/80/24~48 V AC/DC	631060101	RFC-6D
601103003	ELRC-1/80/110/240/415 V AC	631100010	TEMA 10 ANALYSER
601104001	ELRC-1/110/24~48 V AC/DC	631100014	TEMA 14 ANALYSER
601104003	ELRC-1/110/110/240/415 V AC	631100096	TEMA 96 ANALYSER RS232 PORT
601110001	ELR-1/24~48V AC/DC	631100110	TEMA 10H ANALYSER
601110002	ELR-1/110V DC	631100114	TEMA 14H ANALYSER
601110003	ELR-1/110/240/415 V AC	631100196	TEMA 96H ANALYSER RS232
601110101	ELRM-1/24~48V AC/DC	631101010	TEMA 10 ANALYSER-DC
601110102	ELRM-1 110V DC	631101014	TEMA 14 ANALYSER-DC
601110103	ELRM-1/110/240/415 V AC		
601120011	ELR-2S/24~48 V AC/DC	631101101	2, ANALOGUE O/P - PIM
601120012	ELR-2S/110 V DC	631101102	4, ANALOGUE O/P - PIM
601120013	ELR-2S/110/240/415 V AC	631101103	2DIGITAL O/P+2DIGITAL I/P-PIM
601120111	ELRM-2S/24~48 V AC/DC	631101104	4 DIGITAL O/P - PIM
601120112	ELRM-2S/110 V DC	631101105	S485/232 COMMS PORT -PIM
601120113	ELRM-2S/110/240/415 V AC	631101106	1Mb MEMORY -PIM
601130001	ELR-3C/24~48 V AC/DC	631101110	TEMA 10H ANALYSER-DC
601130003	ELR-3C/110/240/415 V AC	631101114	TEMA 14H ANALYSER-DC
601140001	ELR-40/24~48 V AC/DC	631101196	TEMA 96H ANALYSER-DC
601140003	ELR-40/110/240/415 V AC	631102010	TEMA 10 ANALYSER WITH MODBUS
601140101	ELRM-40/24~48 V AC/DC	631102014	TEMA 14 ANALYSER-WITH MODBUS
601140103	ELRM-40/110/240/414 V AC	631102096	TEMA 96 ANALYSER-WITH MODBUS
601150001	ELR-4V/24~48 V AC/DC	631102110	TEMA 10H ANALYSER WITH MODBUS
601150003	ELR-4V/110/240/415 V AC	631102114	TEMA 14H ANALYSER-WITH MODBUS
601150101	ELRM-4V/24~48 V AC/DC	631102196	TEMA 96H ANALYSER-WITH MODBUS
601150103	ELRM-4V/110/240/415 V AC	631103096	TEMA 96 ANALYSER-RS485 PORT
601160003	ELR-51/110/240/415 V AC	631103196	TEMA 96H ANALYSER-RS485
601160013	ELR-52/110/240/415 V AC	631104096	TEMA 96 ANALYSER-1 O/P
601160103	ELRM-51/110/240/415 V AC	631104196	TEMA 96H ANALYSER-1 O/P
601160113	ELRM-52/110/240/415 V AC	631200001	TEMM-4 MULTIMETER
601170001	ELR-61/24~48 V AC/DC	631200002	TEMM-D4 MULTIMETER
601170003	ELR-61/110/240/415 V AC	631200003	TEMM-4T MULTIMETER
601170011	ELR-62/24~48 V AC/DC	631200004	TEMM-4E MULTIMETER
601170013	ELR-62/110/240/415 V AC	631200005	TEMM-4EP MULTIMETER
601170101	ELRM-61/24~48 V AC/DC	631201006	TEMM-4EP-485 MULTIMETER
601170103	ELRM-61/110/240/415 V AC	631201007	TEMM-4EPT-485 MULTIMETER
601170111	ELRM-62/24~48 V AC/DC	631201008	TEMM-D4EP-485 MULTIMETER
601170113	ELRM-62/110/240/415 V AC	631201009	TEMM-D4EPT-485 MULTIMETER
601181005	ELRC-L	631201010	TEMM 4EPN-485 MULTIMETER
601200000	AD	631201011	TEMM 4EPTN-485 MULTIMETER
601210000	EXTERNAL MULTIPLIER	631300002	NRG 2 SOFTWARE
611300111	TCS-1/24~48 V AC/DC	631300004	NRG 4 SOFTWARE
611310113	TCS-2/110/240/415 V AC	631300008	NRG 8 SOFTWARE
621401000	CT-1/35	631300016	NRG 16 SOFTWARE
621402000	CT-1/60	631300028	NRG 128 SOFTWARE
621403000	CT-1/80	631300032	NRG 32 SOFTWARE
621404000	CT-1/110	631300064	NRG 64 SOFTWARE
621405000	CT-1/210	631400101	2 ANALOGUE O/P-PIM
621414000	CTA-1/110		
621415000	CTA-1/210	631400103	2DIGITAL O/P+2DIGITAL I/P-PIM
631030100	RFC-3	631400104	4DIGITAL O/P-PIM
631040100	RFC-4	631400105	S485/232 COMMS PORT-PIM
631040110	RFC-4B	631400106	1Mb MEMORY -PIM
631040200	RFCA	631501000	ELRC-1 COVER 100MM
631060101	RFC-6D	631501054	ELR IP54 COVER
631501500	ELRC-1 COVER 150MM		
621421000	CT-1/S 8 FOR BUSBAR & CABLES	641401000	T35 CURRENT TRANSFORMER
621422000	CT-1/S 10 FOR BUSBAR & CABLES	641402000	T60 CURRENT TRANSFORMER
621423000	CT-1/S 12 FOR BUSBAR & CABLES	641403000	T80 CURRENT TRANSFORMER
621424000	CT-1/S 16 FOR BUSBAR & CABLES	641404000	T110 CURRENT TRANSFORMER
621425000	CT-1/S 20 FOR BUSBAR & CABLES	641405000	T160 CURRENT TRANSFORMER
621426000	CT-1/S 24 FOR BUSBAR & CABLES	641406000	T210 CURRENT TRANSFORMER
621427000	CT-1/S 30 FOR BUSBAR & CABLES	641414000	TA110 CURRENT TRANSFORMER
621428000	CT-1/S 40 FOR BUSBAR & CABLES	641416000	TA210 CURRENT TRANSFORMER
621429000	CT-1/S 60 FOR BUSBAR & CABLES		



Earth Leakage Blocks

211017001	STANDARD ELB FOR 125AF
211017002	ADVANCED ELB FOR 125AF
211017003	STANDARD ELB FOR XS250AF
211017004	ADVANCED ELB FOR XS250AF
211017005	STANDARD ELB FOR XH250AF
211017006	ADVANCED ELB FOR XH250AF

Tropicalisation Cold Climate Treatment

211016001	TROPICALISATION 50 Ø 125AF
211016002	TROPICALISATION 250AF
211016003	TROPICALISATION 400AF
215016004	TROPICALISATION 630/800AF
211016005	TROPICALISATION 1250AF
211016006	TROPICALISATION 1600 Ø 3200AF

TemTransfer Changeover Controllers

302001000	TEMTRANSFER 115V
302001001	TEMTRANSFER (230V)
302001002	TEMTRANSFER INTERFACE KIT
211009156	TEMTRANSFER PANEL/FC/125
211009157	TEMTRANSFER PANEL/FC/250
211009158	TEMTRANSFER PANEL/FC/400
211009160	TEMTRANSFER PANEL/FC/1250/1600
215009159	TEMTRANSFER PANEL/FC/630/800

TERASAKI OVERSEAS NETWORK

TERASAKI (EUROPE) LTD.

80 Beardmore Way, Clydebank Industrial Estate, Clydebank, Glasgow G81 4HT Scotland (UK)
Telephone: 44-141 941-1940 / Fax: 44-141-952-9246 / e-mail: marketing@terasaki.co.uk
www.terasaki.com

TERASAKI ITALIA s.r.l.

Via Campania 4/6, 20090 Segrate, Milano, Italy
Telephone: 39-02-2137574 / Fax: 39-02-26922931 / e-mail: terasaki@terasaki.it
www.terasaki.it

TERASAKI ESPAÑA, S.A.U.

Roma, s/n 08400 Granollers, Barcelona, Spain
Telephone: 34-93-879-60-50 / Fax: 34-93-870-39-05 / e-mail: terasaki@terasaki.es
www.terasaki.es

TERASAKI SKANDINAVISKA AB

Frasarvagan 32, SE-142 50 Skogas, SWEDEN
Telephone: 468-556-28230 / Fax: 468-556-28239 / e-mail: info@terasaki.se
www.terasaki.se

TERASAKI CIRCUIT BREAKERS (S) PTE. LTD.

227 UBI Avenue 4, Singapore 408815, SINGAPORE
Telephone: 65-6744-9752 / Fax: 65-6748-7592 / e-mail: teecs@pacific.net.sg

TERASAKI ELECTRIC (M) SDN. BHD.

Lot 3, Jalan 16/13D, 40000 Shah Alam, Selangor Darul Ehsan, Malaysia
Telephone: 60-3-5549-3820 / Fax: 60-3-5549-3960 / e-mail: terasaki@terasaki.com.my

TERASAKI DO BRASIL LTDA

Rua Cordovil, 259-Parada De Lucas, 21250-450 Rio De Janeiro-R.J., Brazil
Telephone: 55-21-3301-9898 / Fax: 55-21-3301-9861 / e-mail: terasaki@terasaki.com.br
www.terasaki.com.br

TERASAKI ELECTRIC (CHINA) LIMITED

72 Pacific Industrial Park, Xiangtang Zengcheng, Guangzhou 511340, CHINA
Telephone: 86-20-8270-8556 / Fax: 86-20-8270-8586 / e-mail: terasaki@public.guangzhou.gd.cn

TERASAKI ELECTRIC CO., LTD.

Head Office: 7-2-10 Hannancho, Abenoku, Osaka, JAPAN
Circuit Breaker Division: 7-2-10 Kamihigashi, Hiranoku, Osaka, Japan
Telephone: 81-6-791-9323 / Fax: 81-6-791-9274 / e-mail: int-sales@terasaki.co.jp
www.terasaki.co.jp

March 2003 CATALOGUE No. 03-I20E

Ratings and specifications covered in this catalogue may be subject to change without notice.