

MA-MB-PA Modular Prewired Switches

- Metal housing, coated with baked UV resistant powder, cable output from right or bottom
- Saline smoke resistance: ≥ 300 hours in NSS according to ISO 9227
- 3 integrated cable types available
- Version with M12 connector from right or bottom, suitable for safety applications
- Protection degree IP67 & IP69K
- 14 contact blocks available
- 36 actuators available



Always consistent with its innovation and the company quality targets, IMO Precision Controls Ltd introduces three new prewired switches series provided with innovative and unique characteristics. These products series are the result of four years research, development and testing; they fulfil new solutions requested by the market and they include more than twenty years company experience in the position switches sector. That's why we are proud to introduce the new MA, MB and PA in the IMO Precision Controls range.

Options & Ordering Codes

Note: The feasibility of a code number does not mean the effective availability of a product

MA S11 0 A2 - R B 2 G D7 H6 AT

Housing		MA	S11	0	A2	-	R	B	2	G	D7	H6	AT	Transmission Block
metal, 20mm holes interaxes	MA													without transmission block
metal, 25mm holes interaxes	MB													AT 90° transmission block
Contact Blocks														Utilisation Temperatures
1NO+1NC, snap action	S11													-25 °C ... +80 °C
2NC, snap action	S02													H6 -40 °C ... +80 °C
1NO+2NC, snap action	S12													Roller
2NO+2NC, snap action	S22													with Ø 18 mm plastic roller
1NO+1NC, slow action	D11													D7 with Ø 14 mm plastic roller
2NC, slow action	D02													D18 with Ø 18 mm plastic roller
1NO+2NC, slow action	D12													D19 with Ø 22 mm plastic roller
2NO+2NC, slow action	D22													D22 with Ø 20 mm plastic roller
1NO+1NC, slow action overlapped	M11													D23 with Ø 14 mm stainless steel roller
1NO+2NC, slow action overlapped	M12													D24 with Ø 20 mm stainless steel roller
2NO+2NC, slow action overlapped	M22													D25 with Ø 35 mm plastic roller
1NO+1NC, slow action closer	C11													Contacts Type
1NO+2NC, slow action closer	C12													silver contacts (standard)
2NO+2NC, slow action closer	C22													G silver contacts gold plated 1 µm
Other Contact Blocks available on request														
Actuation Heads														Cable Length
without head	0													2 cable length 2 m (standard)
head for revolving level actuators	H													5 cable length 5 m
Actuators														C with connector
with short plunger	A1													Other lengths available upon request
with plunger	A2													Type of Cable
Connection Output Direction														B cable PVC IEC 60332-1 black (standard)
cable or connector from right	R													G cable CEI 20-22 II grey
connector from bottom	B													P cable PUR halogen free grey
														H M12 connector

Switches with connectors

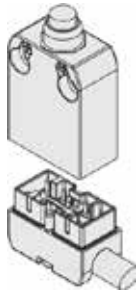

The main new characteristic of the IMO prewired switches is the capability of separating the switch body from the wiring thereby allowing the user to change a product without having to remove the field wiring. Moreover, this way it is easier to assemble and use products with different cable types and lengths.

New actuators

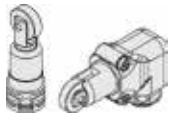

New actuators have been created for the MA, MB and PA, switch series which were not previously available from IMO.

Adjustable cable output

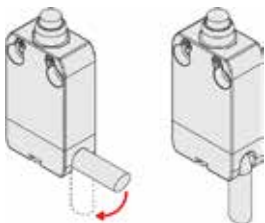

The wired connector is provided with the capability to allow cable bending to 90°, therefore allowing for installation very close to walls.

Rotating heads

All the heads can rotate in 90° steps. When using the revolving lever actuators, they have been designed with dimensions that allow the lever to be positioned such that it is possible to install these switches by a wall.

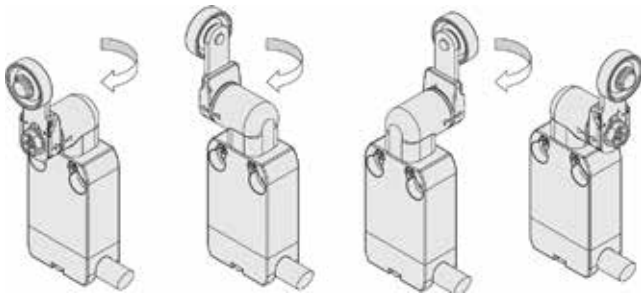

Rotating levers

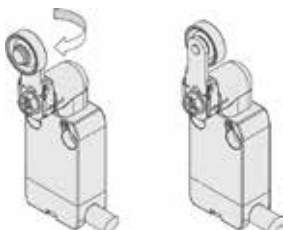

The levers on switches can be placed in “straight” or “reverse side”, whilst still maintaining the positive coupling, this way it is possible to obtain two further working positions of the lever.

Protection degree IP67 and IP69K

IP67
IP69K

These IMO MA, MB and PA series switches are all IP67 and IP69K rated.

Positive opening contact blocks with 1-2-3-4 poles

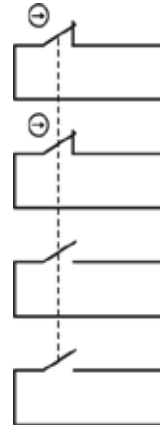

The IMO contact blocks used within the MA, MB and PA switches are versatile and compact, and whilst occupying the same space as previous versions, it is now possible to have up to 4 different contacts, galvanically separated and provided with positive opening (NC contacts). Standard contact combinations available are 1NO+1NC, 2NC, 1NO+2NC and 2NO+2NC although other combinations are available upon request.

The contact blocks are designed so that they maintain the same connection positions in the connector independently of the type of action (slow, snap) and the number of contacts, therefore allowing the use of the same cable connector both for slow action and snap action contacts without crossing wires. Additionally, the above IMO design allows the use of cabled connectors to fit both, more contacts (e.g. 2NO+2NC) or fewer contacts (e.g. 1NO+1NC).

Adjustable levers

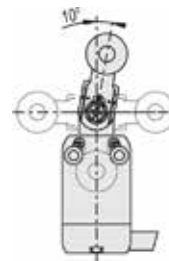

In switch models with a revolving lever actuator it is possible to adjust the lever in 10° steps for the whole 360° rotational range.

The positive movement transmission is always guaranteed thanks to the geometrical coupling between the lever and the revolving shaft which is designed to meet the safety requirements of the German standard BG-GS-ET-15.

Unidirectional heads

All the switches with revolving levers are supplied with a selector which allows the installer to choose the lever operating direction.

The following operations are possible: right-left (industrial standard set up), only from right or only from left. Selection at the directional operation is achieved by revolving a special ring nut inside this type of head.

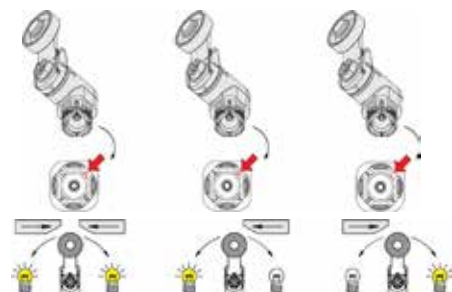

Increased or reduced actuating force

Based on the chosen actuator, many product variants are available, of these actuators with revolving levers are available upon request, with the ability to increase or decrease the actuating force. This feature allows for selection of a switch perfectly tailored for the application. For further information contact the IMO technical support team.

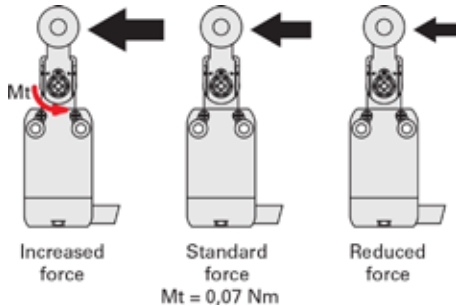

90° transmission block for actuators



This component largely increases the new product's application possibilities. Actuators that can be attached directly to the switch body can also be fitted via the Transmission Block (PPH00-RA) increasing the positioning options and therefore the application possibilities. The Transmission Block can also be used

with revolving lever heads as well as plunger heads

N.B. Even though it is possible with some actuators, it is not advisable to connect more than one Transmission Block to the same switch.

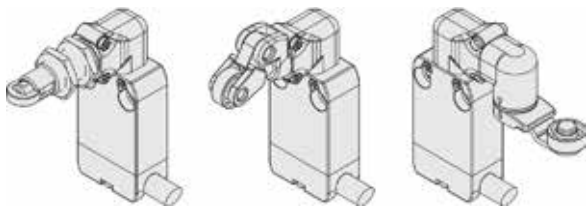

Reversible housing

The fixing holes and switch body design, added with the flexibility of the rotating head, make this switch perfectly symmetrical. If it is necessary to have the switch with cable output from left (the connector cannot be rotated), as opposed to the standard right exit, then it is possible to rotate the device completely, maintaining the unchanged actuator position.

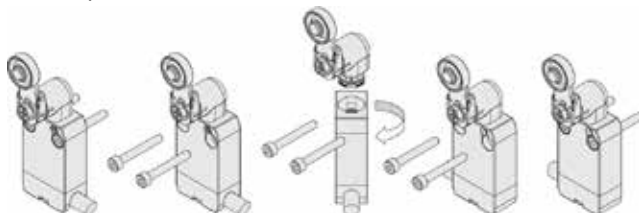

Extended temperature range

-40°C

The IMO MA, MB and PA range of switches are also available in a special version with an extended ambient operating temperature range of -40°C to +80°C. This is particularly useful for applications in cold stores, sterilisers and other low temperature environments.

Adjustable levers with anti-vibration washer

Even once mounted, installation tolerances sometimes require slight variation of the actuator positioning. The majority of revolving levers for MA, MB and PA switches can be adjusted for extension at 1mm intervals. This feature, in conjunction with the radial adjusting actuators provide unique flexibility of alignment whilst still maintaining the geometrical coupling between the lever and the revolving shaft as prescribed for in safety applications.

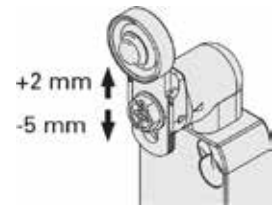

Switch components available separately

The IMO MA, MB and PA products are designed in a modular format, allowing the individual parts to be purchased separately giving stock flexibility for customers requiring spare parts, on-site changes or even new combinations.

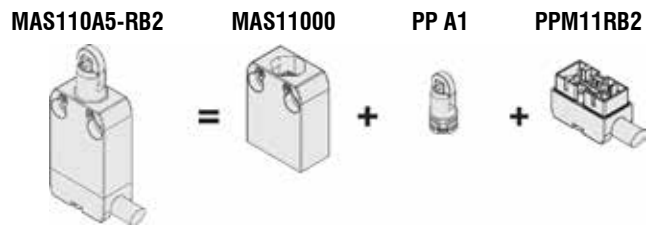

4-8 poles M12 safety connectors

IMO Precision Controls Ltd experience in these switches has led to the development of the first 4-8 pole connector, integrated in a safety switch that complies with the requirements of EN 60947-5-1. The high insulation voltage (Ui 250 Vac) of the device allows these MA, MB and PA parts to be marked as suitable for safety applications with the symbol (direct opening action).



Applications requiring personal protection

Only switches with should be used in applications requiring personal protection. The safety circuit must always be connected to the NC contacts as stipulated in the standard EN 60947-5-1 annex K, para 2. The switch must be actuated by operational movement at least up to the positive travel indicated in the travel diagram; and actuated with a positive opening force (shown in the brackets underneath each part) that is on the line Min. force. All relevant standards to the application must be considered.

Selection diagram for articles MA-MB series sold assembled

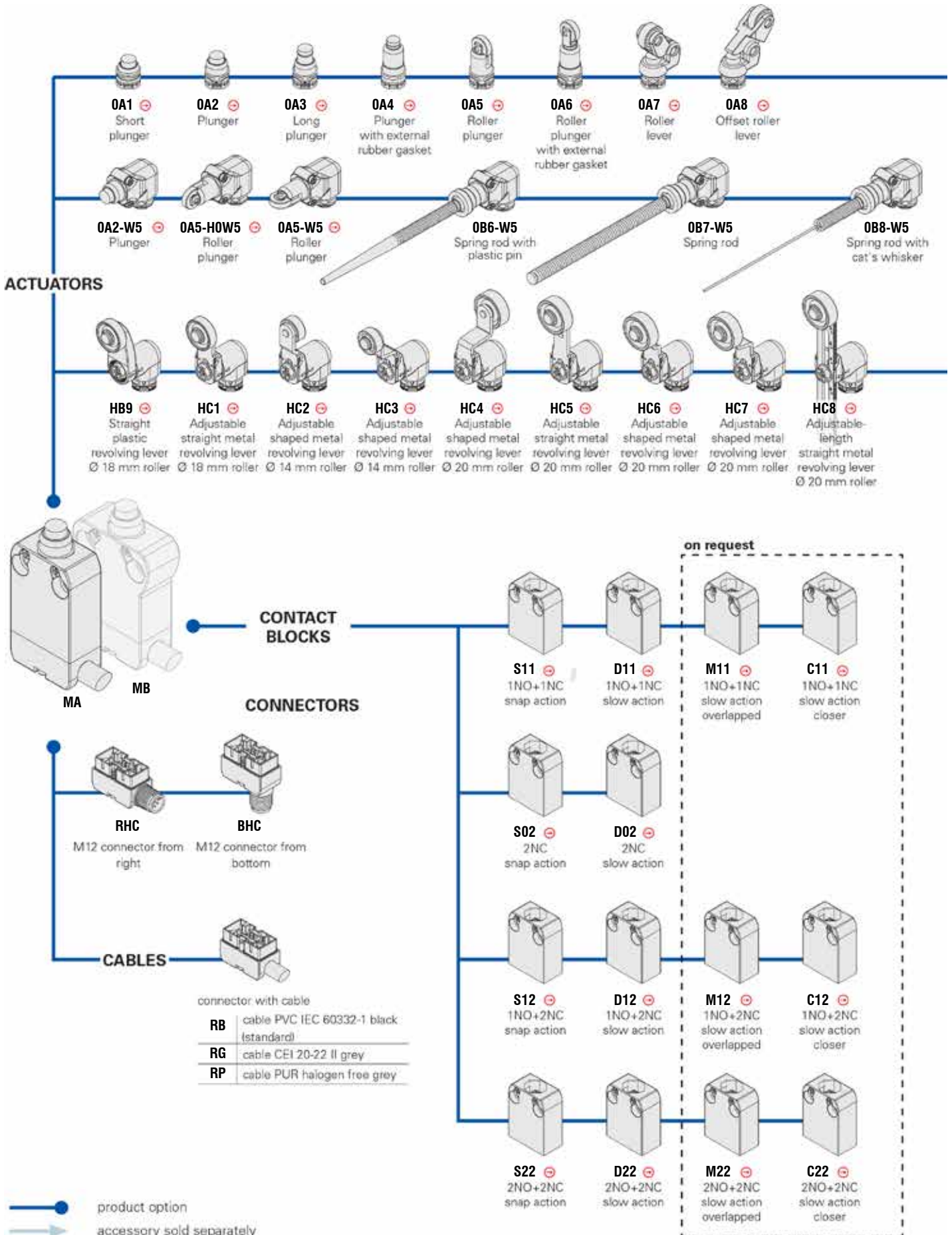

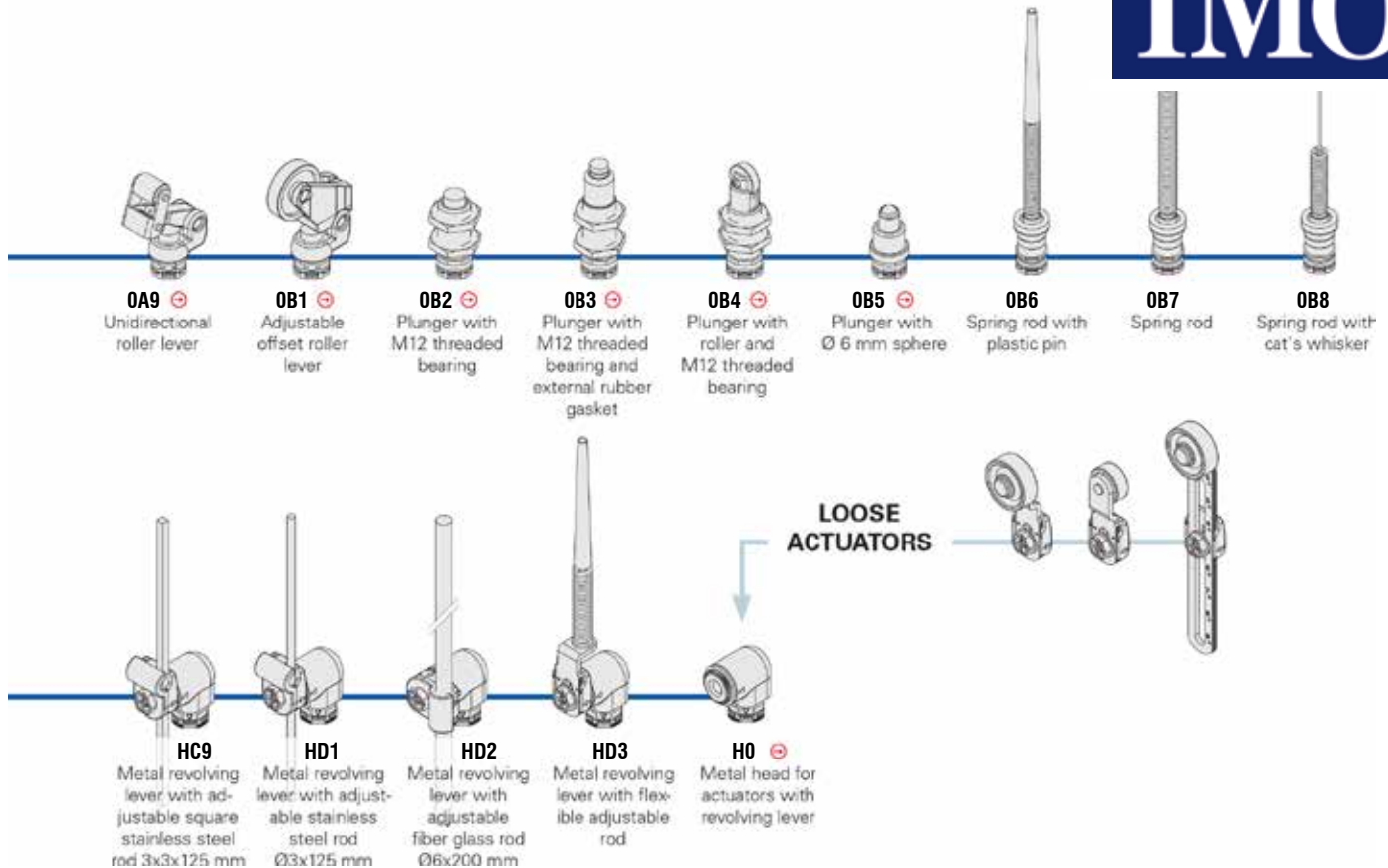

General Data

Utilisation temperatures: See table on next page
 Max. operating frequency 3600 operations cycles*/hour
 Mechanical endurance 20 million operation cycles*
 Assembling position: any

* One operation cycle means two movements, one to close and one to open contacts, as foreseen by EN 60947- 5-1 standard.

Data type approved by UL

Utilization categories: R300 pilot duty (28 VA, 125-250 Vdc), B300 pilot duty (360 VA, 120-240 Vac)
 Data of the housing type 1, 4X "indoor use only", 12
 In conformity with standard: UL 508

In conformity with standards:

IEC 60947-5-1, EN 60947-5-1, IEC 60204-1, EN 60204-1, EN 1088, EN ISO 12100-1, EN ISO 12100-2, IEC 529, EN 60529, NFC 63-140, VDE 0660-200, VDE 0113

In conformity with requirements requested by:

Low Voltage Directive 2006/95/EC, Machinery Directive 2006/42/EC and Electromagnetic Compatibility 2004/108/EC.

Positive contact opening in conformity with standards:

IEC 60947-5-1, EN 60947-5-1, VDE 0660-206.

Installation for persons protection applications:

Use only switches marked with the symbol . The safety circuit must always be connected with the contacts NC as stated in the standard EN 60947-5-1, encl. K, par. 2. The switch must be actuated with at least up to the positive opening travel indicated in the travel diagrams. The switch must be actuated at least with the positive opening force, shown in brackets, underneath each article, near the value of the min. force. All enforceable standards must be respected.

Attention: switch off the circuit voltage before disconnecting the connector from the switch. The connector is not suitable for sectioning of electrical loads. According to EN 60204-1, versions with 8 poles M12 connector can be used only in circuits PELV.

Utilisation temperatures and electrical data:

output with cable								output with connector M12		Output with AMP connector
2 contacts versions				3 contacts versions		4 contacts versions		2 contacts versions	3-4 contacts versions	2 contacts versions
Cable type B 5x0,75 mm ²	Cable type G 5x0,75 mm ²	Cable type P 5x0,75 mm ²	Cable type R 5x0,5mm ²	Cable type B 7x0,5 mm ²	Cable type P 7x0,5 mm ²	Cable type B 9x0,34 mm ²	Cable type R 9x0,5mm ²	5 poles M12 connector	8 poles M12 connector	AMP super seal 1,5 connector
		Max Speed 100 m/min Max Acceleration 2 m/s ²	Cable for railway applications EN50306-4 1E-300V-5x0,5 mm ² MM-90		Max Speed 300 m/min Max Acceleration 25 m/s ²		Cable for railway applications EN50306-4 1P-300V-9x0,5 mm ² MM-90			
Sheath PVC H05VV-F, Not flame-spreading IEC 60332-1-2 IEC 60332-1-3	Sheath PVC S05VV-F, Not flame-spreading IEC 60332-1-2 IEC 60332-1-3 IEC 60332-3 CEI 20-22 II	Sheath PUR HALO-GEN FREE Not flame-spreading IEC 60332-1-2 IEC 60332-1-3	According to: EN 50306-4 EN 45555 Not flame-spreading IEC 60332-1 EN 50305 EN 50306-1	Sheath PVC H05VV-F, Not flame-spreading IEC 60332-1-2 IEC 60332-1-3	Sheath PUR HALO-GEN FREE Not flame-spreading IEC 60332-1-2 IEC 60332-1-3	Sheath PVC H05VV-F, Not flame-spreading IEC 60332-1-2 IEC 60332-1-3	According to: EN 50306-4 EN 45555 Not flame-spreading IEC 60332-1 EN 50305 EN 50306-1			
Min. bend radius: 72 mm	Min. bend radius: 72 mm	Min. bend radius: 70 mm Without halogens Oil-resistant IEC 60811-2-1	Min. bend radius: 60 mm	Min. bend radius: 108 mm	Min. bend radius: 108 mm Without halogens Oil-resistant IEC 60811-2-1	Min. bend radius: 94 mm	Min. bend radius: 60 mm			
Copper class 5 IEC 60228	Copper class 5 IEC 60228	Copper class 6 IEC 60228	Copper class 5 IEC 60228	Copper class 5 IEC 60228	Copper class 6 IEC 60228	Copper class 5 IEC 60228	Copper class 5 IEC 60228			

Utilization temperatures	Standard								Extended -16			
	Fixed laying cable	Flexible laying cable	Dynamic laying cable	Fixed laying cable	Flexible laying cable	Dynamic laying cable	Fixed laying cable	Flexible laying cable	Dynamic laying cable	Thermal current I _{th}	Rated insulation Voltage U _i	Protection against short circuits (fuse)
Electrical data	-25°C ... +70°C	-25°C ... +70°C	-25°C ... +80°C	-25°C ... +80°C	-25°C ... +80°C	-25°C ... +80°C	-25°C ... +80°C	-25°C ... +80°C	-25°C ... +80°C	10 A	250 Vac	10 A 500 V type gG
	+5°C ... +70°C	+5°C ... +70°C	-25°C ... +80°C	-25°C ... +80°C	-5°C ... +80°C	-25°C ... +80°C	-5°C ... +80°C	-25°C ... +80°C	-25°C ... +80°C	10 A	250 Vac	10 A 500 V type gG
	/	/	-25°C ... +80°C	/	/	-25°C ... +80°C	/	/	/	10 A	250 Vac	10 A 500 V type gG
	/	/	-40°C ... +80°C	-40°C ... +80°C	/	-40°C ... +80°C	/	-40°C ... +80°C	-40°C ... +80°C	6 A	250 Vac	6 A 500 V type gG
	/	/	-40°C ... +80°C	-40°C ... +80°C	/	-30°C ... +80°C	/	-40°C ... +80°C	-40°C ... +80°C	6 A	250 Vac	6 A 500 V type gG
	/	/	-40°C ... +80°C	/	/	-30°C ... +80°C	/	/	/	6 A	250 Vac	6 A 500 V type gG
Utilization categories DC13	24 V	2 A	2 A	2 A	2 A	2 A	2 A	2 A	2 A	3 A	250 Vac	3 A 500 V type gG
	125 V	0,4 A	0,4 A	0,4 A	0,4 A	0,4 A	0,4 A	0,4 A	0,4 A	4 A	250 Vac	4 A 500 V type gG
	250 V	0,3 A	0,3 A	0,3 A	0,3 A	0,3 A	0,3 A	0,3 A	0,3 A	3 A	250 Vac	3 A 500 V type gG
	24 V	4 A	4 A	4 A	4 A	4 A	4 A	4 A	4 A	4 A	250 Vac	4 A 500 V type gG
	120 V	4 A	4 A	4 A	4 A	4 A	4 A	4 A	4 A	3 A	250 Vac	3 A 500 V type gG
	250 V	4 A	4 A	4 A	4 A	4 A	4 A	4 A	4 A	3 A	250 Vac	3 A 500 V type gG
Approvals of switches with integrated cable	CE cULus	CE	CE cULus	CE	CE cULus	CE cULus	CE cULus	CE	CE cULus	CE cULus	CE cULus	CE cULus

Internal connections

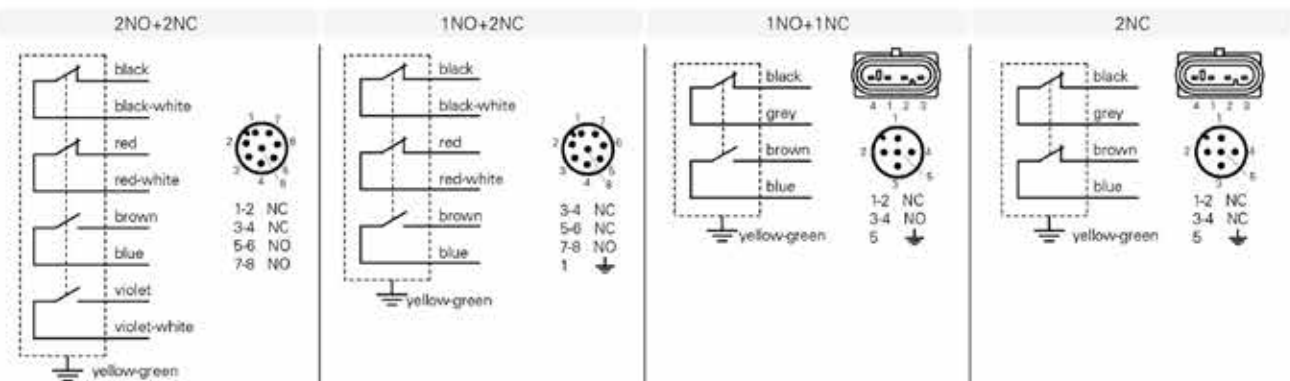

Contacts type:
R = snap action
L = slow action

						With external rubber gasket		
Contact blocks								
S11	R MAS110A1-RB2	⊕ 1NO+1NC	MAS110A2-RB2	⊕ 1NO+1NC	MAS110A3-RB2	⊕ 1NO+1NC	MAS110A4-RB2	⊕ 1NO+1NC
S02	R MAS020A1-RB2	⊕ 2NC	MAS020A2-RB2	⊕ 2NC	MAS020A3-RB2	⊕ 2NC	MAS020A4-RB2	⊕ 2NC
S12	R MAS120A1-RB2	⊕ 1NO+2NC	MAS120A2-RB2	⊕ 1NO+2NC	MAS120A3-RB2	⊕ 1NO+2NC	MAS120A4-RB2	⊕ 1NO+2NC
S22	R MAS220A1-RB2	⊕ 2NO+2NC	MAS220A2-RB2	⊕ 2NO+2NC	MAS220A3-RB2	⊕ 2NO+2NC	MAS220A4-RB2	⊕ 2NO+2NC
D11	L MAD110A1-RB2	⊕ 1NO+1NC	MAD110A2-RB2	⊕ 1NO+1NC	MAD110A3-RB2	⊕ 1NO+1NC	MAD110A4-RB2	⊕ 1NO+1NC
D02	L MAD020A1-RB2	⊕ 2NC	MAD020A2-RB2	⊕ 2NC	MAD020A3-RB2	⊕ 2NC	MAD020A4-RB2	⊕ 2NC
D12	L MAD120A1-RB2	⊕ 1NO+2NC	MAD120A2-RB2	⊕ 1NO+2NC	MAD120A3-RB2	⊕ 1NO+2NC	MAD120A4-RB2	⊕ 1NO+2NC
D22	L MAD220A1-RB2	⊕ 2NO+2NC	MAD220A2-RB2	⊕ 2NO+2NC	MAD220A3-RB2	⊕ 2NO+2NC	MAD220A4-RB2	⊕ 2NO+2NC
Max speed	type 4		type 4		type 4		type 4	
Min. force	7 N (25 N ⊕)		7 N (25 N ⊕)		7 N (25 N ⊕)		7 N (25 N ⊕)	
Travel diagrams	group 1		group 1		group 1		group 1	

		With external rubber gasket		With stainless steel roller on request		With stainless steel roller on request		
Contact blocks								
S11	R MAS110A5-RB2	⊕ 1NO+1NC	MAS110A6-RB2	⊕ 1NO+1NC	MAS110A7-RB2	⊕ 1NO+1NC	MAS110A8-RB2	⊕ 1NO+1NC
S02	R MAS020A5-RB2	⊕ 2NC	MAS020A6-RB2	⊕ 2NC	MAS020A7-RB2	⊕ 2NC	MAS020A8-RB2	⊕ 2NC
S12	R MAS120A5-RB2	⊕ 1NO+2NC	MAS120A6-RB2	⊕ 1NO+2NC	MAS120A7-RB2	⊕ 1NO+2NC	MAS120A8-RB2	⊕ 1NO+2NC
S22	R MAS220A5-RB2	⊕ 2NO+2NC	MAS220A6-RB2	⊕ 2NO+2NC	MAS220A7-RB2	⊕ 2NO+2NC	MAS220A8-RB2	⊕ 2NO+2NC
D11	L MAD110A5-RB2	⊕ 1NO+1NC	MAD110A6-RB2	⊕ 1NO+1NC	MAD110A7-RB2	⊕ 1NO+1NC	MAD110A8-RB2	⊕ 1NO+1NC
D02	L MAD020A5-RB2	⊕ 2NC	MAD020A6-RB2	⊕ 2NC	MAD020A7-RB2	⊕ 2NC	MAD020A8-RB2	⊕ 2NC
D12	L MAD120A5-RB2	⊕ 1NO+2NC	MAD120A6-RB2	⊕ 1NO+2NC	MAD120A7-RB2	⊕ 1NO+2NC	MAD120A8-RB2	⊕ 1NO+2NC
D22	L MAD220A5-RB2	⊕ 2NO+2NC	MAD220A6-RB2	⊕ 2NO+2NC	MAD220A7-RB2	⊕ 2NO+2NC	MAD220A8-RB2	⊕ 2NO+2NC
Max speed	type 2		type 5		type 3		type 3	
Min. force	7 N (25 N ⊕)		7 N (25 N ⊕)		5 N (25 N ⊕)		5 N (25 N ⊕)	
Travel diagrams	group 1		group 1		group 2		group 2	
Housing MB series		M12 connector output from right		M12 connector output from bottom		M12 connector output from bottom		

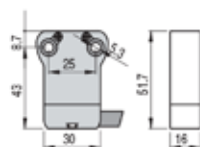

In order to buy a MB series product:
 substitute on above mentioned codes MA with MB.
 Example:
MAS110A1-RB2 → MBS110A1-RB2
 All measures in the drawings are in mm

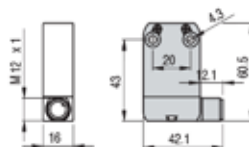

In order to buy a product with M12 connector output from right substitute on above mentioned codes RB2 with RHK. Example:
MAS110A1-RB2 → MAS110A1-RHK

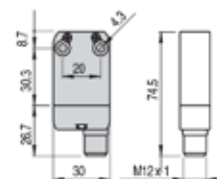

In order to buy a product with M12 connector output from bottom substitute on above mentioned codes RB2 with BHC. Example:
MAS110A1-RB2 → MAS110A1-BHC

Contacts type:
R = snap action
L = slow action

Fixed only by threaded head

Fixed only by threaded head
 With external rubber gasket

Contact blocks							
S11	R	MAS110A9-RB2	⊕ 1NO+1NC	MAS110B1-RB2	⊕ 1NO+1NC	MAS110B2-RB2	⊕ 1NO+1NC
S02	R	MAS020A9-RB2	⊕ 2NC	MAS020B1-RB2	⊕ 2NC	MAS020B2-RB2	⊕ 2NC
S12	R	MAS120A9-RB2	⊕ 1NO+2NC	MAS120B1-RB2	⊕ 1NO+2NC	MAS120B2-RB2	⊕ 1NO+2NC
S22	R	MAS220A9-RB2	⊕ 2NO+2NC	MAS220B1-RB2	⊕ 2NO+2NC	MAS220B2-RB2	⊕ 2NO+2NC
D11	L	MAD110A9-RB2	⊕ 1NO+1NC	MAD110B1-RB2	⊕ 1NO+1NC	MAD110B2-RB2	⊕ 1NO+1NC
D02	L	MAD020A9-RB2	⊕ 2NC	MAD020B1-RB2	⊕ 2NC	MAD020B2-RB2	⊕ 2NC
D12	L	MAD120A9-RB2	⊕ 1NO+2NC	MAD120B1-RB2	⊕ 1NO+2NC	MAD120B2-RB2	⊕ 1NO+2NC
D22	L	MAD220A9-RB2	⊕ 2NO+2NC	MAD220B1-RB2	⊕ 2NO+2NC	MAD220B2-RB2	⊕ 2NO+2NC
Max speed		type 3		type 3		type 4	
Min. force		3 N (25 N ⊕)		3 N (25 N ⊕)		7 N (25 N ⊕)	
Travel diagrams		group 6		group 3		group 1	

Fixed only by threaded head

With external rubber gasket

With external rubber gasket

Contact blocks							
S11	R	MAS110B4-RB2	⊕ 1NO+1NC	MAS110B5-RB2	⊕ 1NO+1NC	MAS110B6-RB2	1NO+1NC
S02	R	MAS020B4-RB2	⊕ 2NC	MAS020B5-RB2	⊕ 2NC	MAS020B6-RB2	2NC
S12	R	MAS120B4-RB2	⊕ 1NO+2NC	MAS120B5-RB2	⊕ 1NO+2NC	MAS120B6-RB2	1NO+2NC
S22	R	MAS220B4-RB2	⊕ 2NO+2NC	MAS220B5-RB2	⊕ 2NO+2NC	MAS220B6-RB2	2NO+2NC
D11	L	MAD110B4-RB2	⊕ 1NO+1NC	MAD110B5-RB2	⊕ 1NO+1NC	MAD110B6-RB2	1NO+1NC
D02	L	MAD020B4-RB2	⊕ 2NC	MAD020B5-RB2	⊕ 2NC	MAD020B6-RB2	2NC
D12	L	MAD120B4-RB2	⊕ 1NO+2NC	MAD120B5-RB2	⊕ 1NO+2NC	MAD120B6-RB2	1NO+2NC
D22	L	MAD220B4-RB2	⊕ 2NO+2NC	MAD220B5-RB2	⊕ 2NO+2NC	MAD220B6-RB2	2NO+2NC
Max speed		type 2		type 2		1 m/s	
Min. force		7 N (25 N ⊕)		7 N (25 N ⊕)		0,03 Nm	
Travel diagrams		group 1		group 1		group 4	

Accessories

Article	Description
AC DT1F	Spacers for MA-PA series
VF D16B	Spacers for MB series

By interposing spacers between the switches, it is possible to join two or more prewired switches, preventing them from moving one against the other.
10 pcs packs

Article	Description
M12F0xx	Female wired connectors



General data:
 - Please refer to <http://www.imopc.com/products/FAMILY76750000>

Contacts type:
R = snap action
L = slow action

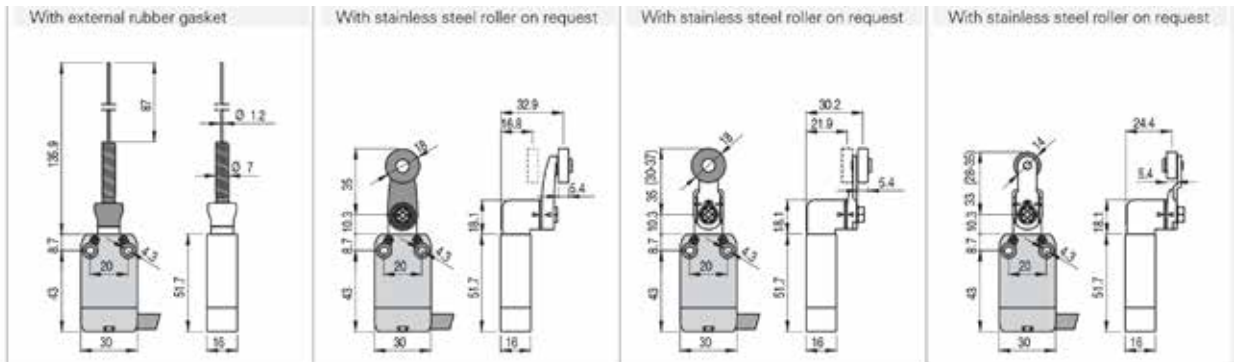

Contact blocks

S11	R	MAS110B8-RB2	1NO+1NC	MAS11HB9-RB2	⊕ 1NO+1NC	MAS11HC1-RB2	⊕ 1NO+1NC	MAS11HC2-RB2	⊕ 1NO+1NC
S02	R	MAS020B8-RB2	2NC	MAS02HB9-RB2	⊕ 2NC	MAS02HC1-RB2	⊕ 2NC	MAS02HC2-RB2	⊕ 2NC
S12	R	MAS120B8-RB2	1NO+2NC	MAS12HB9-RB2	⊕ 1NO+2NC	MAS12HC1-RB2	⊕ 1NO+2NC	MAS12HC2-RB2	⊕ 1NO+2NC
S22	R	MAS220B8-RB2	2NO+2NC	MAS22HB9-RB2	⊕ 2NO+2NC	MAS22HC1-RB2	⊕ 2NO+2NC	MAS22HC2-RB2	⊕ 2NO+2NC
D11	L	MAD110B8-RB2	1NO+1NC	MAD11HB9-RB2	⊕ 1NO+1NC	MAD11HC1-RB2	⊕ 1NO+1NC	MAD11HC2-RB2	⊕ 1NO+1NC
D02	L	MAD020B8-RB2	2NC	MAD02HB9-RB2	⊕ 2NC	MAD02HC1-RB2	⊕ 2NC	MAD02HC2-RB2	⊕ 2NC
D12	L	MAD120B8-RB2	1NO+2NC	MAD12HB9-RB2	⊕ 1NO+2NC	MAD12HC1-RB2	⊕ 1NO+2NC	MAD12HC2-RB2	⊕ 1NO+2NC
D22	L	MAD220B8-RB2	2NO+2NC	MAD22HB9-RB2	⊕ 2NO+2NC	MAD22HC1-RB2	⊕ 2NO+2NC	MAD22HC2-RB2	⊕ 2NO+2NC
Max speed		1 m/s		type 1		type 1		type 1	
Min. force		0,03 Nm		0,07 Nm (0,25 Nm ⊕)		0,07 Nm (0,25 Nm ⊕)		0,07 Nm (0,25 Nm ⊕)	
Travel diagrams		group 4		group 5		group 5		group 5	

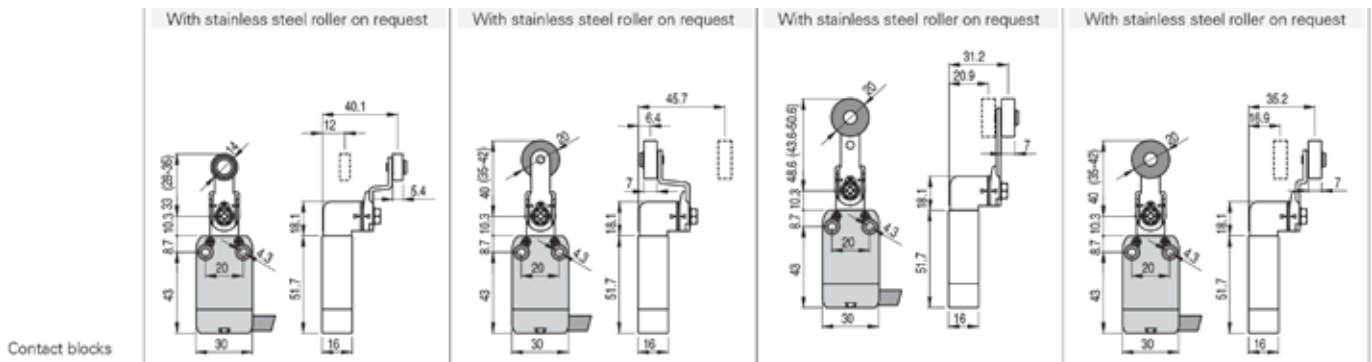

Contact blocks

S11	R	MAS11HC3-RB2	⊕ 1NO+1NC	MAS11HC4-RB2	⊕ 1NO+1NC	MAS11HC5-RB2	⊕ 1NO+1NC	MAS11HC6-RB2	⊕ 1NO+1NC
S02	R	MAS02HC3-RB2	⊕ 2NC	MAS02HC4-RB2	⊕ 2NC	MAS02HC5-RB2	⊕ 2NC	MAS02HC6-RB2	⊕ 2NC
S12	R	MAS12HC3-RB2	⊕ 1NO+2NC	MAS12HC4-RB2	⊕ 1NO+2NC	MAS12HC5-RB2	⊕ 1NO+2NC	MAS12HC6-RB2	⊕ 1NO+2NC
S22	R	MAS22HC3-RB2	⊕ 2NO+2NC	MAS22HC4-RB2	⊕ 2NO+2NC	MAS22HC5-RB2	⊕ 2NO+2NC	MAS22HC6-RB2	⊕ 2NO+2NC
D11	L	MAD11HC3-RB2	⊕ 1NO+1NC	MAD11HC4-RB2	⊕ 1NO+1NC	MAD11HC5-RB2	⊕ 1NO+1NC	MAD11HC6-RB2	⊕ 1NO+1NC
D02	L	MAD02HC3-RB2	⊕ 2NC	MAD02HC4-RB2	⊕ 2NC	MAD02HC5-RB2	⊕ 2NC	MAD02HC6-RB2	⊕ 2NC
D12	L	MAD12HC3-RB2	⊕ 1NO+2NC	MAD12HC4-RB2	⊕ 1NO+2NC	MAD12HC5-RB2	⊕ 1NO+2NC	MAD12HC6-RB2	⊕ 1NO+2NC
D22	L	MAD22HC3-RB2	⊕ 2NO+2NC	MAD22HC4-RB2	⊕ 2NO+2NC	MAD22HC5-RB2	⊕ 2NO+2NC	MAD22HC6-RB2	⊕ 2NO+2NC
Max speed		type 1		type 1		type 1		type 1	
Min. force		0,07 Nm (0,25 Nm ⊕)		0,07 Nm (0,25 Nm ⊕)		0,07 Nm (0,25 Nm ⊕)		0,07 Nm (0,25 Nm ⊕)	
Travel diagrams		group 5		group 5		group 5		group 5	

Housing MB series

M12 connector output from right

M12 connector output from bottom

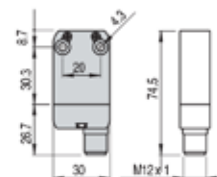
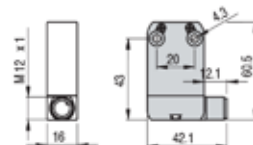
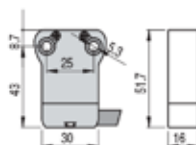

In order to buy a MB series product:
 substitute on above mentioned codes MA with MB.
 Example:
 MAS110A1-RB2 → MBS110A1-RB2

In order to buy a product with M12 connector
 output from right substitute on above
 mentioned codes RB2 with RHC. Example:
 MAS110A1-RB2 → MAS110A1-RHC

In order to buy a product with M12 connector
 output from bottom substitute on above
 mentioned codes RB2 with BHC. Example:
 MAS110A1-RB2 → MAS110A1-BHC

Contacts type:
R = snap action
L = slow action

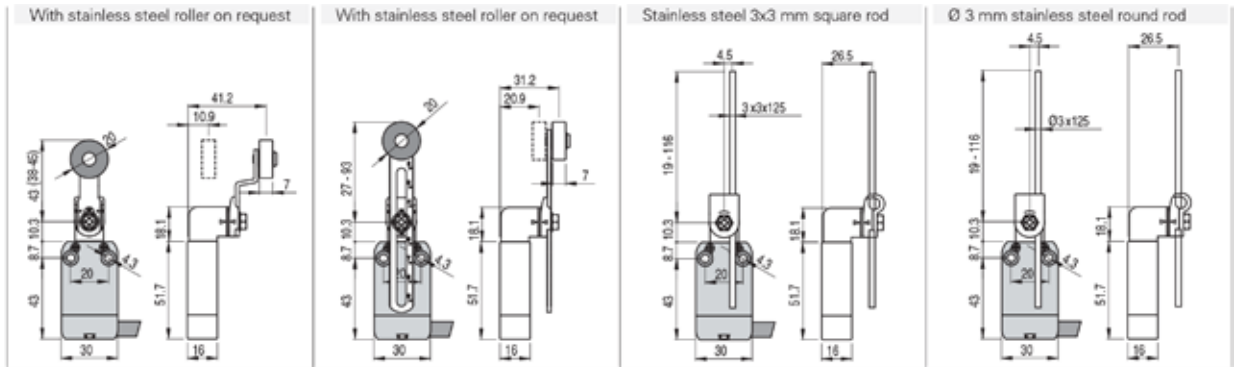

Contact blocks

S11	R	MAS11HC7-RB2	⊕ 1NO+1NC	MAS11HC8-RB2	⊕ 1NO+1NC	MAS11HC9-RB2	1NO+1NC	MAS11HD1-RB2	1NO+1NC
S02	R	MAS02HC7-RB2	⊕ 2NC	MAS02HC8-RB2	⊕ 2NC	MAS02HC9-RB2	2NC	MAS02HD1-RB2	2NC
S12	R	MAS12HC7-RB2	⊕ 1NO+2NC	MAS12HC8-RB2	⊕ 1NO+2NC	MAS12HC9-RB2	1NO+2NC	MAS12HD1-RB2	1NO+2NC
S22	R	MAS22HC7-RB2	⊕ 2NO+2NC	MAS22HC8-RB2	⊕ 2NO+2NC	MAS22HC9-RB2	2NO+2NC	MAS22HD1-RB2	2NO+2NC
D11	L	MAD11HC7-RB2	⊕ 1NO+1NC	MAD11HC8-RB2	⊕ 1NO+1NC	MAD11HC9-RB2	1NO+1NC	MAD11HD1-RB2	1NO+1NC
D02	L	MAD02HC7-RB2	⊕ 2NC	MAD02HC8-RB2	⊕ 2NC	MAD02HC9-RB2	2NC	MAD02HD1-RB2	2NC
D12	L	MAD12HC7-RB2	⊕ 1NO+2NC	MAD12HC8-RB2	⊕ 1NO+2NC	MAD12HC9-RB2	1NO+2NC	MAD12HD1-RB2	1NO+2NC
D22	L	MAD22HC7-RB2	⊕ 2NO+2NC	MAD22HC8-RB2	⊕ 2NO+2NC	MAD22HC9-RB2	2NO+2NC	MAD22HD1-RB2	2NO+2NC
Max speed	type 1			type 1		1,5 m/s		1,5 m/s	
Min. force	0,07 Nm (0,25 Nm ⊖)			0,07 Nm (0,25 Nm ⊕)		0,07 Nm		0,07 Nm	
Travel diagrams	group 5			group 5		group 5		group 5	

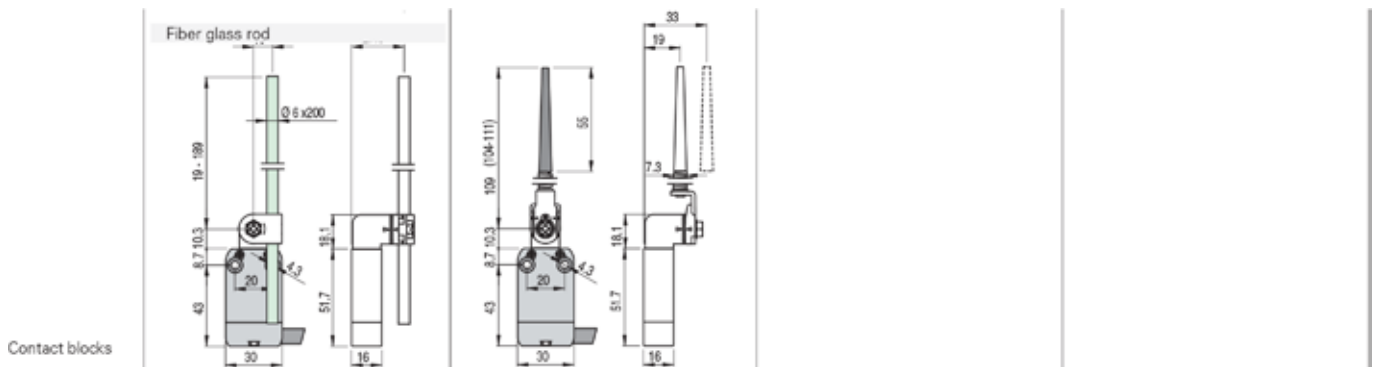

Contact blocks

S11	R	MAS11HD2-RB2	1NO+1NC	MAS11HD3-RB2	1NO+1NC				
S02	R	MAS02HD2-RB2	2NC	MAS02HD3-RB2	2NC				
S12	R	MAS12HD2-RB2	1NO+2NC	MAS12HD3-RB2	1NO+2NC				
S22	R	MAS22HD2-RB2	2NO+2NC	MAS22HD3-RB2	2NO+2NC				
D11	L	MAD11HD2-RB2	1NO+1NC	MAD11HD3-RB2	1NO+1NC				
D02	L	MAD02HD2-RB2	2NC	MAD02HD3-RB2	2NC				
D12	L	MAD12HD2-RB2	1NO+2NC	MAD12HD3-RB2	1NO+2NC				
D22	L	MAD22HD2-RB2	2NO+2NC	MAD22HD3-RB2	2NO+2NC				
Max speed	1,5 m/s			1,5 m/s					
Min. force	0,07 Nm			0,07 Nm					
Travel diagrams	group 5			group 5					

Accessories

Article	Description
AC DT1F	Spacers for MA-PA series
VF D16B	Spacers for MB series

By interposing spacers between the switches, it is possible to join two or more prewired switches, preventing them from moving one against the other.
10 pcs packs

Article	Description
M12F0xx	Female wired connectors

General data:
 - Please refer to <http://www.imopc.com/products/FAMILY76750000>

Contacts type:

- R** = snap action
- L** = slow action

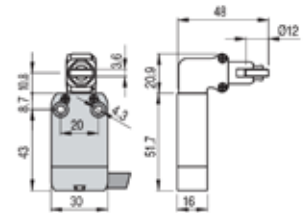
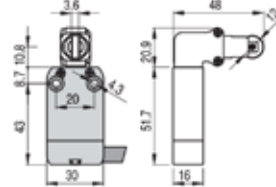
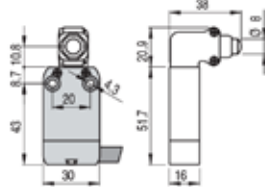

Contact blocks

S11	R	MAS110A2-RB2AT	⊕ 1NO+1NC	MAS110A5-RB2HOAT	⊕ 1NO+1NC	MAS110A5-RB2AT	⊕ 1NO+1NC
S02	R	MAS020A2-RB2AT	⊕ 2NC	MAS020A5-RB2HOAT	⊕ 2NC	MAS020A5-RB2AT	⊕ 2NC
S12	R	MAS120A2-RB2AT	⊕ 1NO+2NC	MAS120A5-RB2HOAT	⊕ 1NO+2NC	MAS120A5-RB2AT	⊕ 1NO+2NC
S22	R	MAS220A2-RB2AT	⊕ 2NO+2NC	MAS220A5-RB2HOAT	⊕ 2NO+2NC	MAS220A5-RB2AT	⊕ 2NO+2NC
D11	L	MAD110A2-RB2AT	⊕ 1NO+1NC	MAD110A5-RB2HOAT	⊕ 1NO+1NC	MAD110A5-RB2AT	⊕ 1NO+1NC
D02	L	MAD020A2-RB2AT	⊕ 2NC	MAD020A5-RB2HOAT	⊕ 2NC	MAD020A5-RB2AT	⊕ 2NC
D12	L	MAD120A2-RB2AT	⊕ 1NO+2NC	MAD120A5-RB2HOAT	⊕ 1NO+2NC	MAD120A5-RB2AT	⊕ 1NO+2NC
D22	L	MAD220A2-RB2AT	⊕ 2NO+2NC	MAD220A5-RB2HOAT	⊕ 2NO+2NC	MAD220A5-RB2AT	⊕ 2NO+2NC
Max speed	type 4			type 2		type 2	
Min. force	9,5 N (25 N ⊕)			9,5 N (25 N ⊕)		9,5 N (25 N ⊕)	
Travel diagrams	group 1			group 1		group 1	

With external rubber gasket

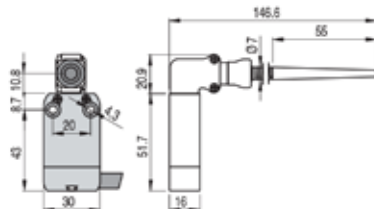

With external rubber gasket

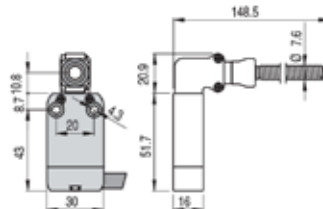

With external rubber gasket

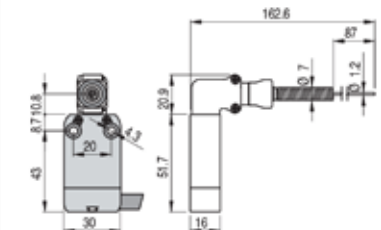

Contact blocks

S11	R	MAS110B6-RB2AT	1NO+1NC	MAS110B7-RB2AT	1NO+1NC	MAS110B8-RB2AT	1NO+1NC
S02	R	MAS020B6-RB2AT	2NC	MAS020B7-RB2AT	2NC	MAS020B8-RB2AT	2NC
S12	R	MAS120B6-RB2AT	1NO+2NC	MAS120B7-RB2AT	1NO+2NC	MAS120B8-RB2AT	1NO+2NC
S22	R	MAS220B6-RB2AT	2NO+2NC	MAS220B7-RB2AT	2NO+2NC	MAS220B8-RB2AT	2NO+2NC
D11	L	MAD110B6-RB2AT	1NO+1NC	MAD110B7-RB2AT	1NO+1NC	MAD110B8-RB2AT	1NO+1NC
D02	L	MAD020B6-RB2AT	2NC	MAD020B7-RB2AT	2NC	MAD020B8-RB2AT	2NC
D12	L	MAD120B6-RB2AT	1NO+2NC	MAD120B7-RB2AT	1NO+2NC	MAD120B8-RB2AT	1NO+2NC
D22	L	MAD220B6-RB2AT	2NO+2NC	MAD220B7-RB2AT	2NO+2NC	MAD220B8-RB2AT	2NO+2NC
Max speed	1 m/s			1 m/s		1 m/s	
Min. force	0,08 Nm			0,12 Nm		0,08 Nm	
Travel diagrams	group 4			group 4		group 4	

Housing MB series

M12 connector output from right

M12 connector output from bottom

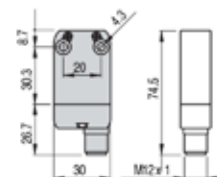
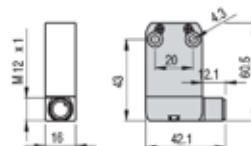
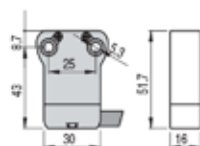

In order to buy a MB series product:
substitute on above mentioned codes MA with MB.
Example:
MAS110A1-RB2 → MBS110A1-RB2

In order to buy a product with M12 connector output from right substitute on above mentioned codes RB2 with RHC. Example:
MAS110A1-RB2 → MAS110A1-RHC

In order to buy a product with M12 connector output from bottom substitute on above mentioned codes RB2 with BHC. Example:
MAS110A1-RB2 → MAS110A1-BHC

Diagrams Table

Contact block	Group 1	Group 2	Group 3	Group 4	Group 5	Group 6
S11 1NO+1NC						
S02 2NC						
S12 1NO+2NC						
S22 2NO+2NC						
D11 1NO+1NC				/		
D02 2NC						
D12 1NO+2NC				/		
D22 2NO+2NC				/		
M11 1NO+1NC						
M12 1NO+2NC						
M22 2NO+2NC						
C11 1NO+1NC						
C12 1NO+2NC						
C22 2NO+2NC						

Legend

Closed contact |
 Opened contact |
 Positive opening travel |
 Pushing the switch /
 Releasing the switch

PA Modular Prewired Switches

- Glass reinforced polymer housing, self extinguishing, shockproof thermoplastic resin
- Saline smoke resistance: ≥ 300 hours in NSS according to ISO 9227
- 3 integrated cable types available
- Version with M12 connector from right or bottom, suitable for safety applications
- Protection degree IP67
- 14 contact blocks available
- 23 actuators available



Approval UL: E146236



Always consistent with its innovation and the company quality targets, IMO Precision Controls Ltd introduces three new prewired switches series provided with innovative and unique characteristics. These products series are the result of four years research, development and testing; they fulfil new solutions requested by the market and they include more than twenty years company experience in the position switches sector. That's why we are proud to introduce the new MA, MB and PA in the IMO Precision Controls range.

Options & Ordering Codes

Note: The feasibility of a code number does not mean the effective availability of a product

PA		S11	0	A2	-	R	B	2	G	D7	AT
Housing		Transmission Block									
Polymer, 20mm holes interaxes		without transmission block									
PA		AT 90° transmission block									
Contact Blocks		Roller									
1NO+1NC, snap action	S11	with Ø 18 mm plastic roller									
2NC, snap action	S02	D7 with Ø 14 mm plastic roller									
1NO+2NC, snap action	S12	D18 with Ø 18 mm plastic roller									
2NO+2NC, snap action	S22	D19 with Ø 22 mm plastic roller									
1NO+1NC, slow action	D11	D22 with Ø 20 mm plastic roller									
2NC, slow action	D02	D23 with Ø 14 mm stainless steel roller									
1NO+2NC, slow action	D12	D24 with Ø 20 mm stainless steel roller									
2NO+2NC, slow action	D22	D25 with Ø 35 mm plastic roller									
1NO+1NC, slow action overlapped	M11	Contacts Type									
1NO+2NC, slow action overlapped	M12	silver contacts (standard)									
2NO+2NC, slow action overlapped	M22	G silver contacts gold plated 1 µm									
1NO+1NC, slow action closer	C11	Cable Length									
1NO+2NC, slow action closer	C12	2 cable length 2 m (standard)									
2NO+2NC, slow action closer	C22	5 cable length 5 m									
Other Contact Blocks available on request		C with connector									
		Other lengths available upon request									
Actuation Heads		Type of Cable									
without head	0	B cable PVC IEC 60332-1 black (standard)									
head for revolving level actuators	2	G cable CEI 20-22 II grey									
Actuators		P cable PUR halogen free grey									
with short plunger	A1	H M12 connector									
with plunger	A2										
Connection Output Direction											
cable or connector from right	R										
connector from bottom	B										

MA-MB-PA Modular Prewired Switches

Selection diagram for articles MA - MB - PA series sold separately

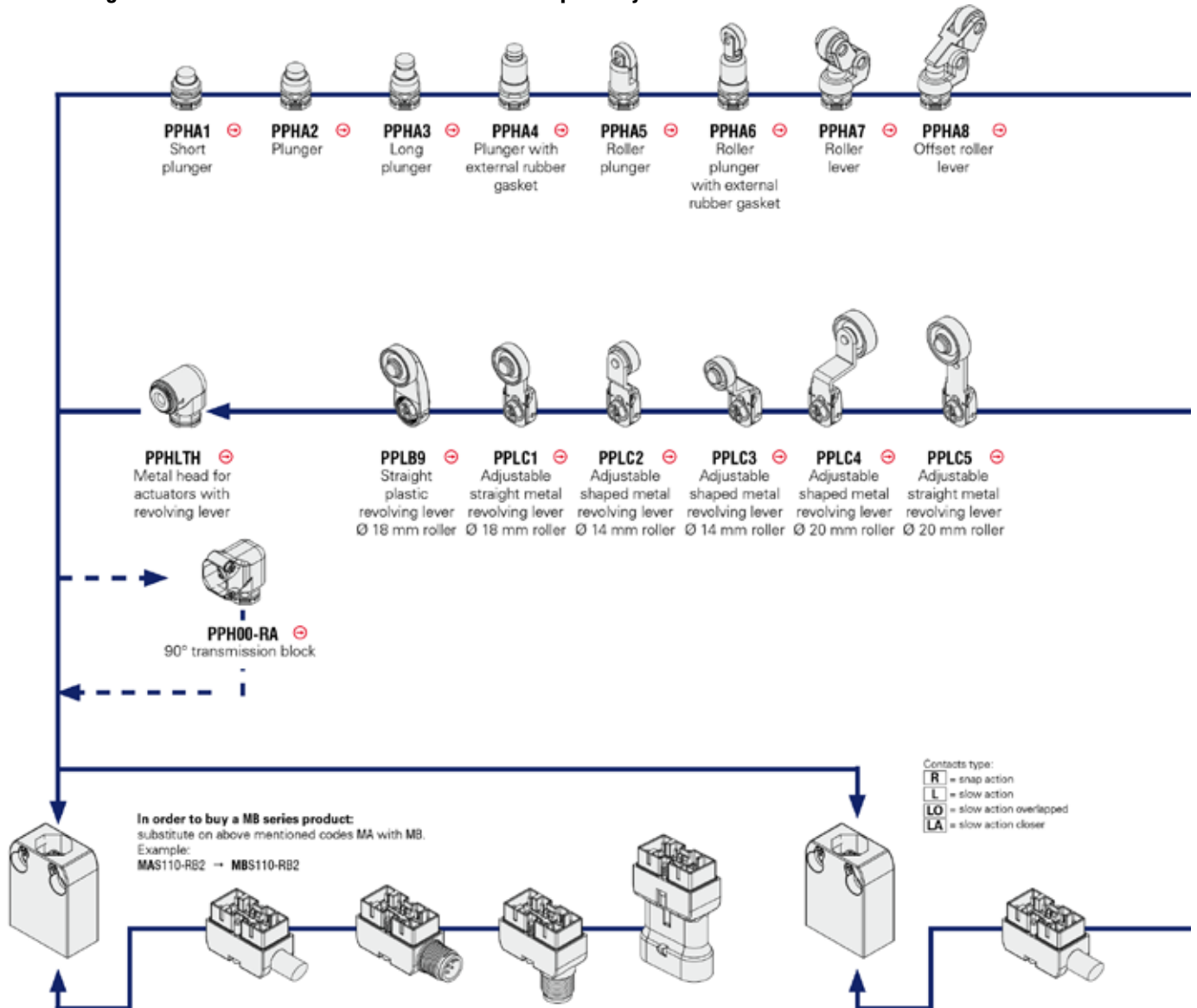

METAL housing MA 20 mm holes interaxes	Metal connector with cable cable length(m)	M12 metal connector from right	M12 metal connector from bottom,	AMP type polymer connector from bottom	POLYMER housing PA 20 mm holes interaxes	Polymer connectors with cable cable length(m)
MAS11000 ⊕ 1NO+1NC [R]	PPM11RB2 2	PPM11RH ↔	PPM11BH ↔	PPM11BA ↔	PAS11000 ⊕ 1NO+1NC [R]	PPP11RB2 2
MAD11000 ⊕ 1NO+1NC [L]	PPM11RB5 5				PAD11000 ⊕ 1NO+1NC [L]	PPP11RB5 5
MAC11000 ⊕ 1NO+1NC [LA]	PPM02RB2 2 PPM02RB5 5	PPM02RH ↔	PPM02BH ↔	PPM02BA ↔	PAL11000 ⊕ 1NO+1NC [LA]	PPP02RB2 2 PPP02RB5 5
MAM11000 ⊕ 1NO+1NC [LO]					PAM11000 ⊕ 1NO+1NC [LO]	
MAS02000 ⊕ 2NC [R]	/	PPM20RH ↔	PPM20BH ↔	PPM20BA ↔	PAS02000 ⊕ 2NC [R]	/
MAD02000 ⊕ 2NC [L]					PAD02000 ⊕ 2NC [L]	
MAS20000 ⊕ 2NO [R]	/	PPM12RH ↔	PPM12BH ↔	PPM12BA ↔	PAS20000 ⊕ 2NO [R]	/
MAD20000 ⊕ 2NO [L]					PAD20000 ⊕ 2NO [L]	
MAS12000 ⊕ 1NO+2NC [R]	PPM12RB2 2	PPM22RH ↔	PPM22BH ↔	PPM22BA ↔	PAS12000 ⊕ 1NO+2NC [R]	PPP12RB2 2
MAD12000 ⊕ 1NO+2NC [L]	PPM12RB5 5				PAS22000 ⊕ 2NO+2NC [R]	PPP22RB2 2
MAC12000 ⊕ 1NO+2NC [LA]	PPM22RB2 2 PPM22RB5 5	PPM22RH ↔	PPM22BH ↔	PPM22BA ↔	PAL12000 ⊕ 1NO+2NC [LA]	PPP22RB5 5
MAM12000 ⊕ 1NO+2NC [LO]					PAM12000 ⊕ 1NO+2NC [LO]	
MAS22000 ⊕ 2NO+2NC [R]	/	PPM22RH ↔	PPM22BH ↔	PPM22BA ↔	PAS22000 ⊕ 2NO+2NC [R]	/
MAD22000 ⊕ 2NO+2NC [L]					PAD22000 ⊕ 2NO+2NC [L]	
MAC22000 ⊕ 2NO+2NC [LA]	/	PPM22RH ↔	PPM22BH ↔	PPM22BA ↔	PAC22000 ⊕ 2NO+2NC [LA]	/
MAM22000 ⊕ 2NO+2NC [LO]					PAM22000 ⊕ 2NO+2NC [LO]	

⚠ Forbidden to install PPM***** connector on polymer housing

⚠ Forbidden to install PPP***** connector on metal housing

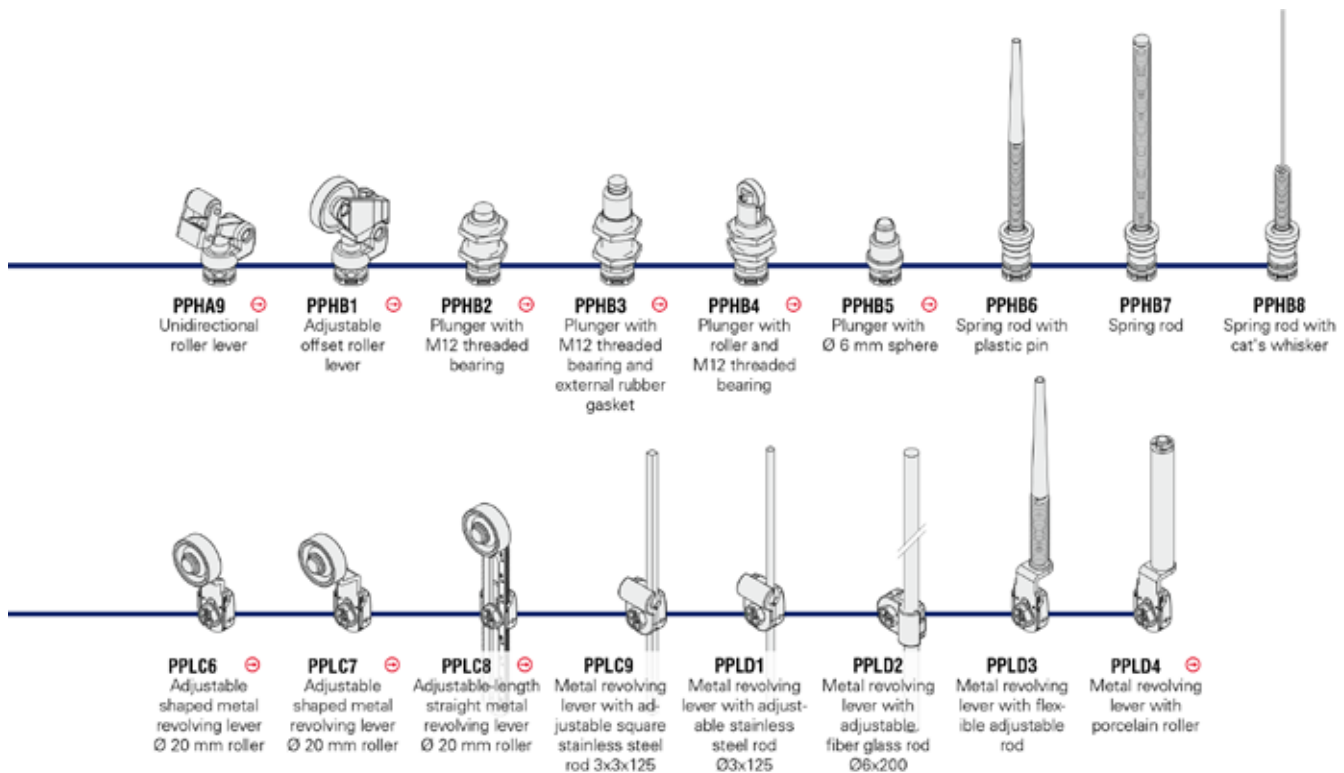

⚠ Installation for persons protection applications:

In order to obtain a safety switch with positive opening ⊕, assemble housings having the positive opening symbol next to the code ⊕ with actuators having the positive opening symbol next to the code ⊖.

Example: PPLC1⊖ + PPHLTH⊖ + MAS110NA⊕

Examples of article code composition

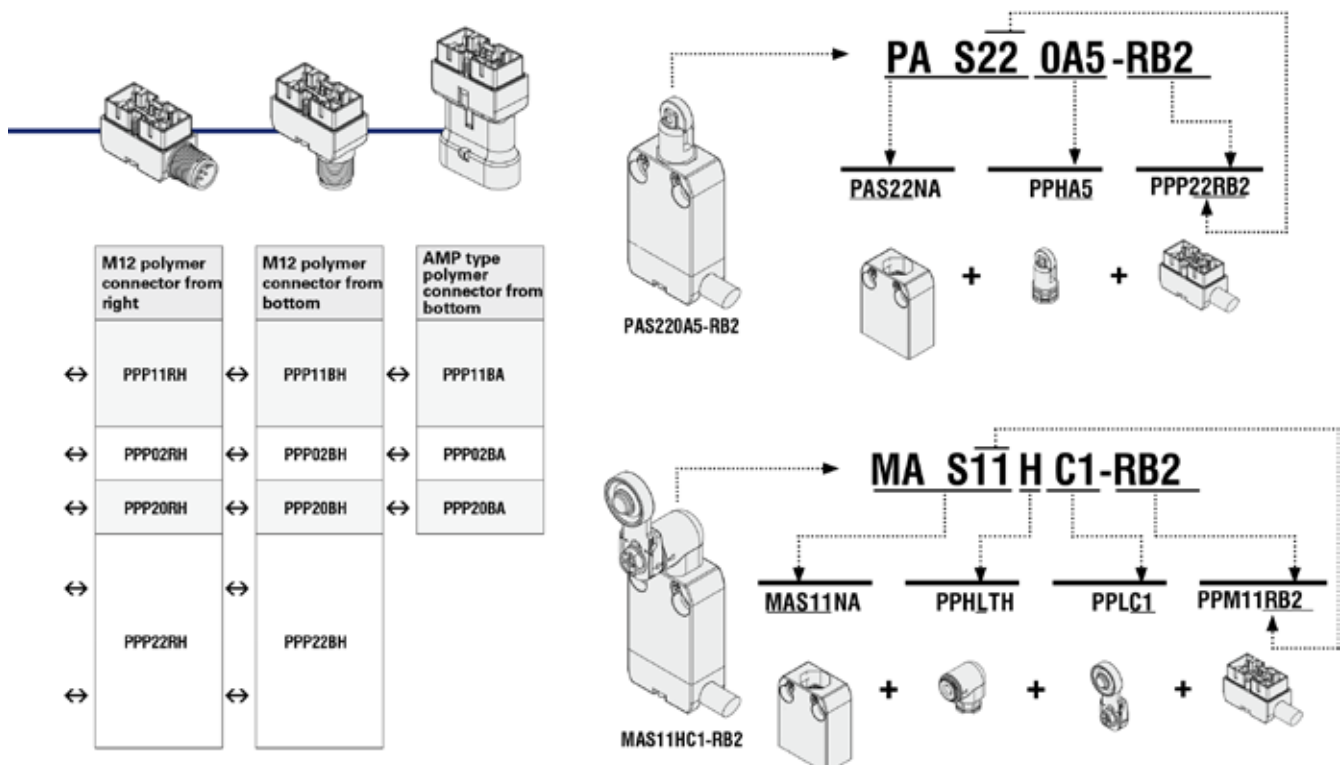

Housings

metal housing MA	metal housing MB
MA S11000 ⊕ 1NO+1NC [R]	MB S11000 ⊕ 1NO+1NC [R]
MA D11000 ⊕ 1NO+1NC [L]	MB D11000 ⊕ 1NO+1NC [L]
MA S12000 ⊕ 1NO+2NC [R]	MB S12000 ⊕ 1NO+2NC [R]
MA D12000 ⊕ 1NO+2NC [L]	MB D12000 ⊕ 1NO+2NC [L]
MA C12000 ⊕ 1NO+2NC [LA]	MB C12000 ⊕ 1NO+2NC [LA]
MA S22000 ⊕ 2NO+2NC [R]	MB S22000 ⊕ 2NO+2NC [R]
MA D22000 ⊕ 2NO+2NC [L]	MB D22000 ⊕ 2NO+2NC [L]
MA C22000 ⊕ 2NO+2NC [LA]	MB C22000 ⊕ 2NO+2NC [LA]
MA M22000 ⊕ 2NO+2NC [LO]	MB M22000 ⊕ 2NO+2NC [LO]

Contacts type:
 [R] = snap action
 [L] = slow action
 [LO] = slow action overlapped
 [LA] = slow action closer

polymer housing PA
PA S110NA ⊕ 1NO+1NC [R]
PA D110NA ⊕ 1NO+1NC [L]
PA S120NA ⊕ 1NO+2NC [R]
PA D120NA ⊕ 1NO+2NC [L]
PA C120NA ⊕ 1NO+2NC [LA]
PA S220NA ⊕ 2NO+2NC [R]
PA D220NA ⊕ 2NO+2NC [L]
PA C220NA ⊕ 2NO+2NC [LA]
PA M220NA ⊕ 2NO+2NC [LO]

Connector with cable

metal connectors for MA and MB housing		Cable length(m)	Cable type B = PVC Fixed laying cable H = PUR HALOGEN FREE Dynamic laying cable
PP M11RB2 1NO+1NC		2	B
PP M11RB5 1NO+1NC		5	
PP M12RB2 1NO+2NC		2	
PP M12RB5 1NO+2NC		5	
PP M22RB2 2NO+2NC		2	
PP M22RB5 2NO+2NC		5	
PP M11RH2 1NO+1NC		2	H
PP M11RH5 1NO+1NC		5	
PP M12RH2 1NO+2NC		2	
PP M12RH5 1NO+2NC		5	

Other cable lengths on request

polymer connectors for PA housing		Cable length(m)	Cable type B = PVC Fixed laying cable
PP P11RB2 1NO+1NC		2	B
PP P11RB5 1NO+1NC		5	
PP P12RB2 1NO+2NC		2	
PP P12RB5 1NO+2NC		5	
PP P22RB2 2NO+2NC		2	
PP P22RB5 2NO+2NC		5	

M12 or AMP connector

⚠ Attention: Always check that the electric load used respects the voltage and current limits for the connectors.

metal connectors for MA and MB housing	
M12 connector from right 	M12 connector from bottom
PP M11RH 1NO+1NC	PP M11BH 1NO+1NC
PP M02RH 2NC	PP M02BH 2NC
PP M22RH 2NO+2NC	PP M22BH 2NO+2NC

polymer connectors for PA housing	
M12 connector from right 	M12 connector from bottom
PP P11RH 1NO+1NC	PP P11BH 1NO+1NC
PP P02RH 2NC	PP P02BH 2NC
PP P22RH 2NO+2NC	PP P22BH 2NO+2NC

polymer connectors for MA and MB housing	
AMP super seal 1,5 connector 	
PP M11BA 1NO+1NC	
PP M02BA 2NC	
PP M20BA 2NO	

AMP super seal 1,5 connector	
PP P11BA 1NO+1NC	
PP P02BA 2NC	
PP P20BA 2NO	

Actuators

 PPHA1	 PPHA2	 PPHA3	 PPHA4	 PPHA5	 PPHA6
 PPHA7	 PPHA8	 PPHA9	 PPHB1	 PPHB2	 PPHB3
 PPHB4	 PPHB5	 PPHB6	 PPHB7	 PPHB8	

Revolving levers

ATTENTION: These loose actuators can be used with products of series MA, MB and PA only.

 PPLB9	 PPLC1	 PPLC2	 PPLC3	 PPLC4	 PPLC5
 PPLC6	 PPLC7	 PPLC8	 PPLC9	 PPLD1	 PPLD2
 PPLD3	 PPLD4				

Head

 PPHLTH

Transmission block

 PPH00-RA

Utilisation temperatures and electrical data:

Output with cable				Output with M12 connector		Output with connector AMP
2 contacts versions		3 contacts versions	4 contacts versions	2 contacts versions	3/4 contacts versions	2 contacts versions
Cable type B 4x0,75 mm ²	Cable type G 4x0,75 mm ²	Cable type B 6x0,5 mm ²	Cable type B 8x0,34 mm ²	4 poles M12 connector	8 poles M12 connector	AMP super seal 1,5 connector
Sheath PVC H06VV-F Not flame-spreading IEC 60332-1-2 IEC 60332-1-3	Sheath PVC H06VV-F Not flame-spreading IEC 60332-1-2 IEC 60332-1-3 IEC 60332-3 CEI 20-22 II	Sheath PVC H06VV-F Not flame-spreading IEC 60332-1-2 IEC 60332-1-3	Sheath PVC H06VV-F Not flame-spreading IEC 60332-1-2 IEC 60332-1-3			
Min. bend radius: 72 mm	Min. bend radius: 72 mm	Min. bend radius: 108 mm	Min. bend radius: 94 mm			
Copper class 5 IEC 60228	Copper class 5 IEC 60228	Copper class 5 IEC 60228	Copper class 5 IEC 60228			

Utilization temperatures	Standard temperature	Fixed laying cable	-25°C ... +70°C	-25°C ... +70°C	-25°C ... +80°C	-25°C ... +80°C			
	Extended temperature -T6	Flexible laying cable	+5°C ... +70°C	+5°C ... +70°C	+5°C ... +80°C	-5°C ... +80°C			-25°C ... +80°C
		Dynamic laying cable	/	/	/	/			
Fixed laying cable		/	/	/	/				
	Flexible laying cable	/	/	/	/			-40°C ... +80°C	
	Dynamic laying cable	/	/	/	/				
Electrical data	Thermal current I _{th}	10 A	10 A	6 A	3 A	4 A	2 A	10 A	
	Rated insulation Voltage U _i	250 Vac	250 Vac	250 Vac	250 Vac	250 Vac 300 Vdc	30 Vac 36 Vdc	250 Vac 300 Vdc	
	Protection against short circuits (fuse)	10 A 500 V type gG	10 A 500 V type gG	6 A 500 V type gG	3 A 500 V type gG	4 A 500 V type gG	2 A 500V type gG	10 A 500 V type gG	
	Conditional short circuit current according with EN 60947-5-1	1000 A	1000 A	1000 A	1000 A	1000 A	1000 A	1000 A	
	Utilization categories DC13	24 V	2 A	2 A	2 A	2 A	2 A	2 A	2 A
		125 V	0,4 A	0,4 A	0,4 A	0,4 A	0,4 A	/	0,4 A
		250 V	0,3 A	0,3 A	0,3 A	0,3 A	0,3 A	/	0,3 A
	Utilization categories AC15	24 V	4 A	4 A	4 A	4 A	4 A	2 A	4 A
		120 V	4 A	4 A	4 A	4 A	4 A	/	4 A
		250 V	4 A	4 A	4 A	4 A	4 A	/	4 A
Approvals of switches with integrated cable	CE, cULus	CE	CE, cULus	CE, cULus	CE, cULus	CE, cULus	CE, cULus	CE, cULus	

Internal connections

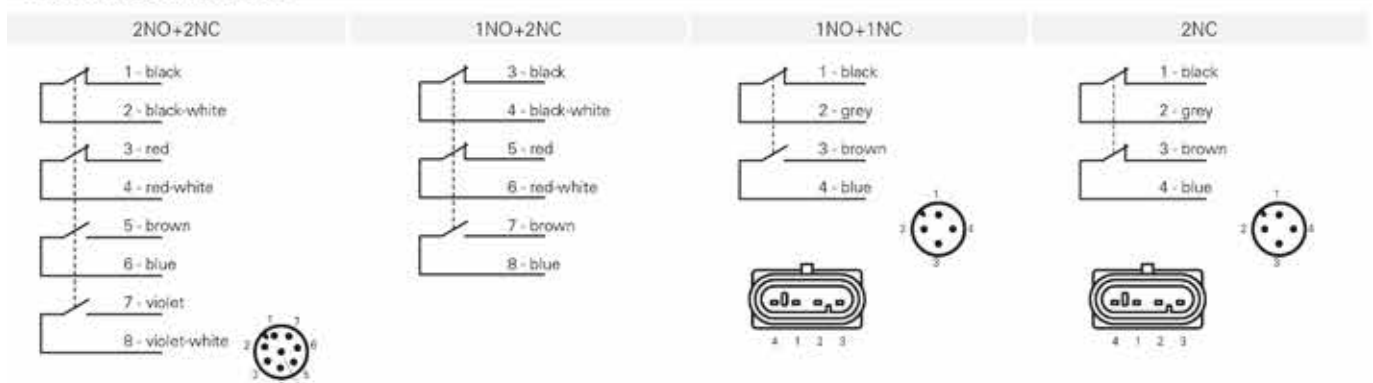

Maximum and minimum actuation speed

Roller lever - Type 1

φ	Vmax (m/s)	Vmin (mm/s) [L]	Vmin (mm/s) [R]
15°	2,5	9	0,07
30°	1,5	8	
45°	1	7	
60°	0,75	7	

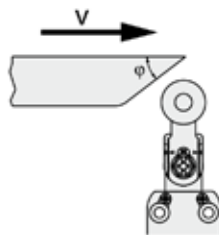

Plunger with roller - Type 2

φ	Vmax (m/s)	Vmin (mm/s) [L]	Vmin (mm/s) [R]
15°	1	4	0,04
30°	0,5	2	0,02
45°	0,3	1	0,01

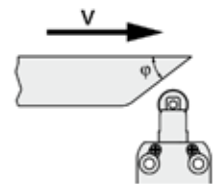

Roller lever - Type 3

φ	Vmax (m/s)	Vmin (mm/s) [L]	Vmin (mm/s) [R]
15°	1	5	0,05
30°	0,5	2,5	0,025
45°	0,3	1,5	0,015

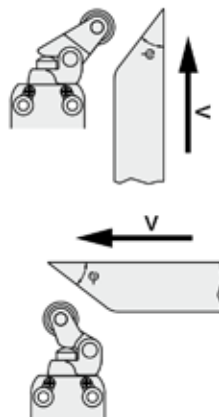

Plunger - Type 4

Vmax (m/s)	Vmin (mm/s) [L]	Vmin (mm/s) [R]
0,5	1	0,01

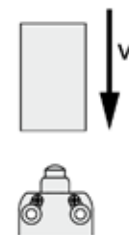

Plunger with roller - Type 5

φ	Vmax (m/s)	Vmin (mm/s) [L]	Vmin (mm/s) [R]
15°	0,3	4	0,04

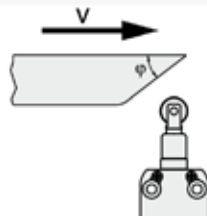

Contacts type:

[R] = snap action
[L] = slow action

Driving torques:

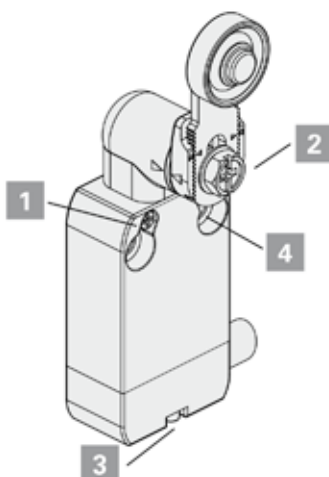

MA-MB Series

Head screws **1**
Lever screws **2**
Connectors screws **3**
M4 housing fastening screws **4**

0,5 ... 0,7 Nm
0,8 ... 1,2 Nm
0,3 ... 0,6 Nm
2... 3 Nm

PA Series

Head screws **1**
Lever screws **2**
Connectors screws **3**
M4 housing fastening screws **4**

0,3 ... 0,4 Nm
0,8 ... 1,2 Nm
0,2 ... 0,3 Nm
2... 3 Nm