

## NZ1HS-528-M (ORDER NO. 090970)

Safety switch NZ.HS, lever arm with steel roller

- ▶ Version A according to EN 50041(steel roller ø 18 mm)
- ▶ Cable entry M20 x 1.5



### Description

#### Approach direction

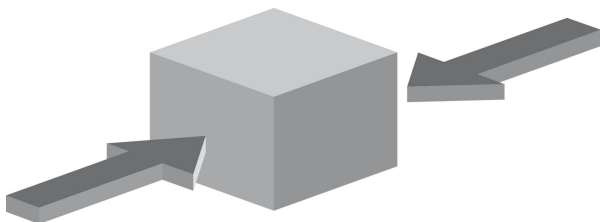

Figure

Horizontal

#### switching direction

- ▶ Right, left or both sides

#### Switching element

528H Slow-action switching contact 1 NC  + 1 NO

#### Dimension drawing

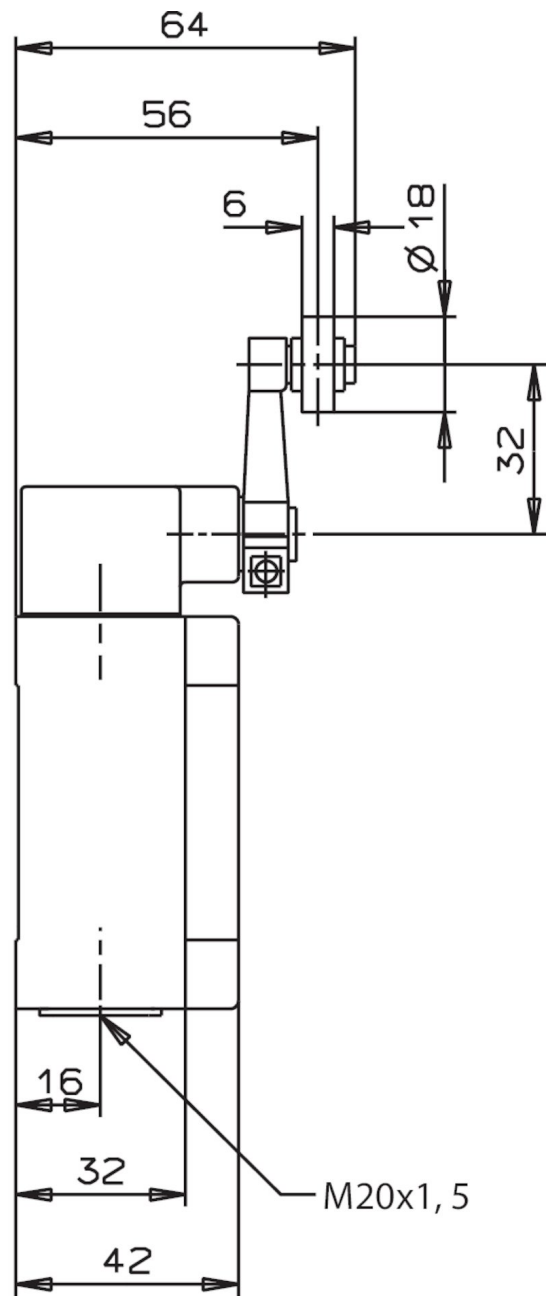
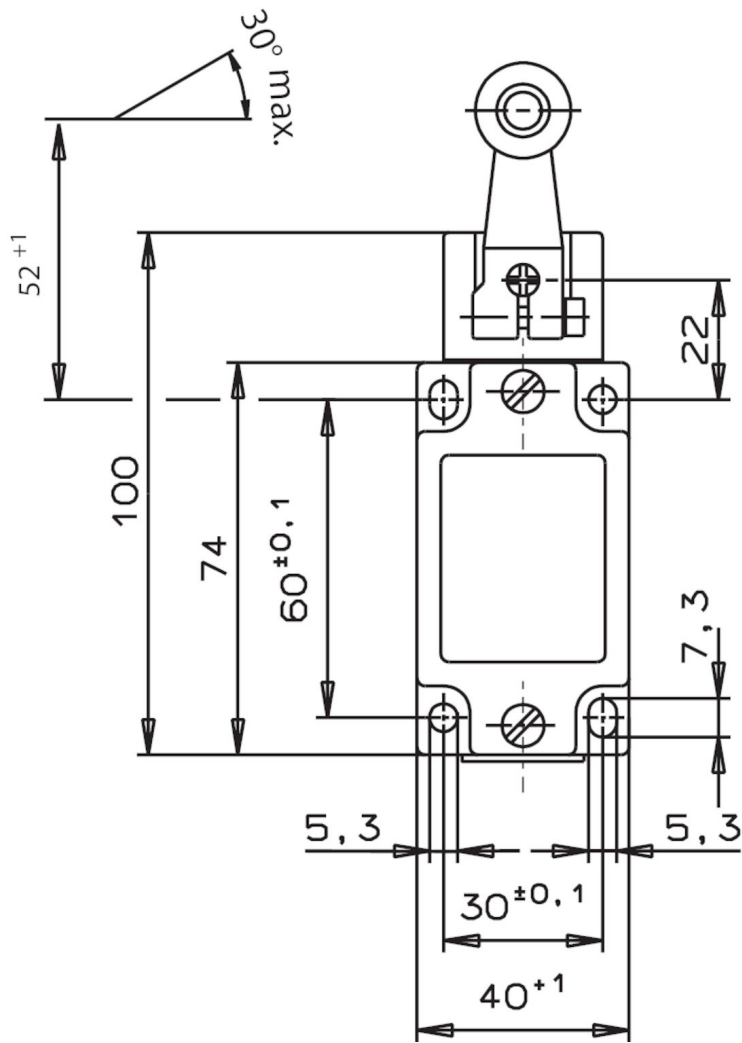

528H

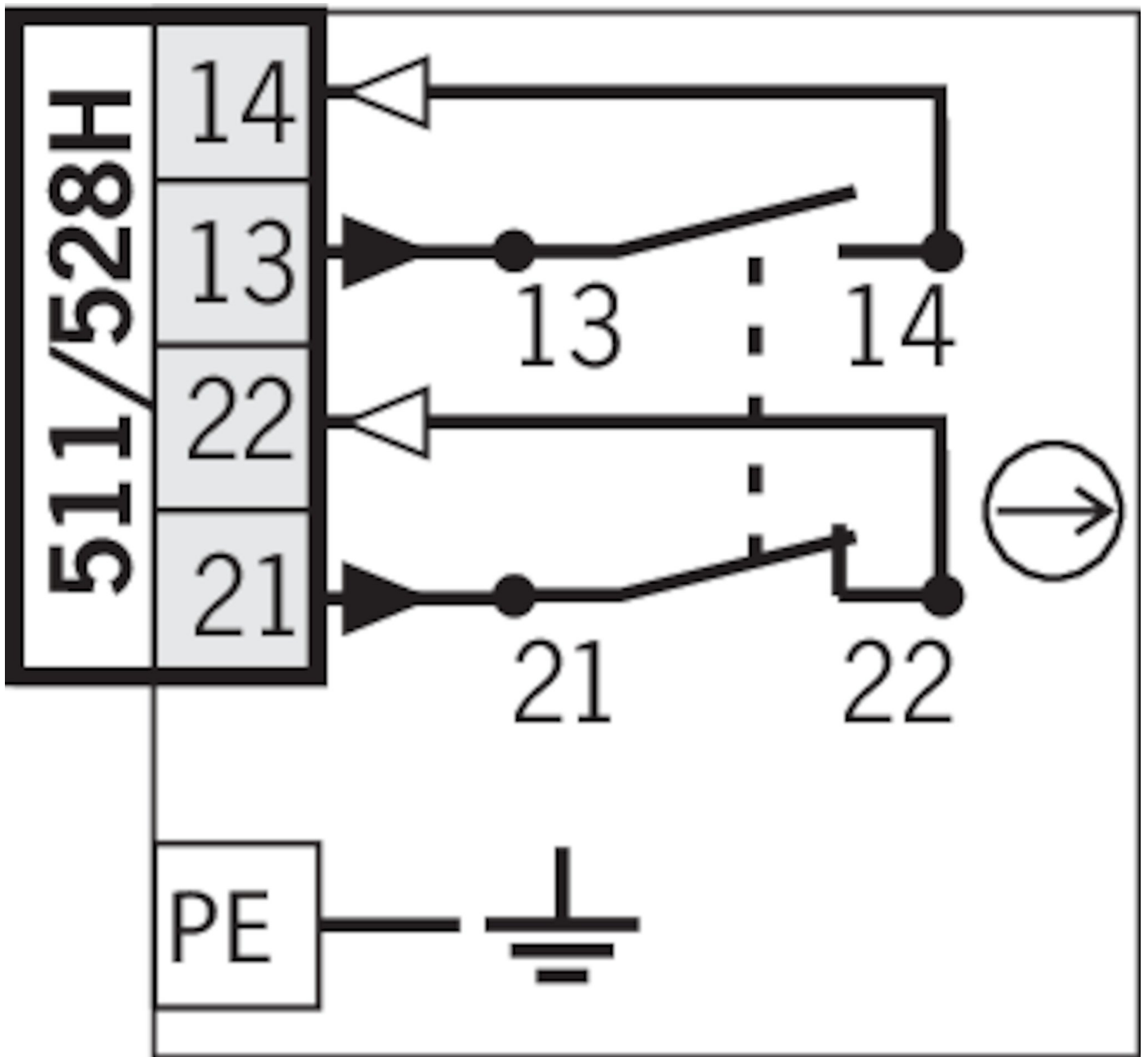



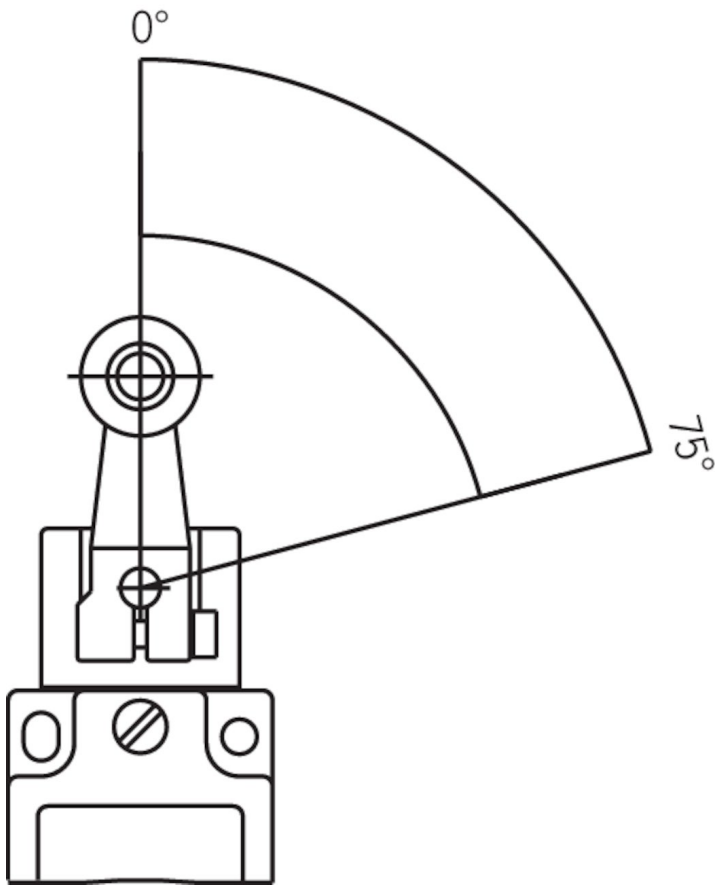

Travel diagram

# NZ...HS NZ...HB

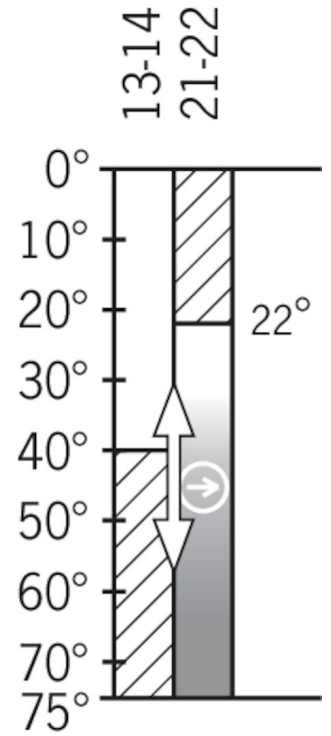

# 528H



-  Contacts closed
-  Contacts open
-  Contacts positively driven

## Technical data

### Approvals



### Mechanical values and environment

## Housing material

	Housing	Anodized die-cast alloy
Weight	Net	0,3 kg
Ambient temperature		-25 ... 80 °C
Degree of protection		IP67
Mechanical life		30 x 10 <sup>6</sup>
Contact material		Silver alloy, gold flashed
Switching principle		Slow-action switching contact
Installation orientation		Any
Number of door position positively driven contacts		1
Number of NO contacts		1
Connection		1 x M20 x 1.5
Approach speed		0,1 ... 60 m/min
Actuating element	Plain bearing metal	Lever arm (d roller = 18 mm, length 32 mm)
Actuating force		min.15 N

## Electrical connection ratings

Thermal rated current I <sub>th</sub>		4 A
Utilization category acc. to EN 60947-5-1		
	AC-15	4A 230V
	DC-13	4A 24V
Short circuit protection according to IEC 60269-1		4A gG
Rated insulation voltage U <sub>i</sub>		250 V
Rated impulse withstand voltage U <sub>imp</sub>		2,5 kV
Switching current		
	Min. at DC 24V	1 mA
Connection cross-section		0,34 ... 1,5 mm <sup>2</sup>

## Reliability values according to EN ISO 13849-1

		<b>Monitoring of the safety guard position</b>
B10 <sub>D</sub>		20 x 10 <sup>6</sup>

## Accessories

### Connection material

## Cable glands M20x1.5, cable Ø 6.5-9.5 mm

---



077683  
EKVM20/06

## Cable glands M20x1.5, cable Ø 9-13 mm

---



077684  
EKVM20/09

## Spare parts

### Lever arm with steel roller

---



012043  
NHS ROLLENHEBEL

▶ Steel roller Ø18 mm

## Contacts

🏠 EUCHNER GmbH + Co. KG  
Kohlhammerstraße 16  
70771 Leinfelden-Echterdingen

☎ +49 711 7597-0

📠 +49 711 753316

✉ info(at)euchner.de