



# HAWKER LEVEL CONTROL SYSTEMS

## Light Duty Multi Electrode Holder Type E14

The E14 is available in 2, 3 or 4 way versions to accommodate up to four 3.2mm diameter electrodes. The body is moulded in polypropylene with a screw on cap. The mounting thread is 3/4 B.S.P. parallel. In addition, a lock nut is provided. The screwed conduit entry is 20mm diameter. Electrodes (other than Hastelloy) are plastic coated to prevent tracking. For applications where excessive moisture is present, a recessed headed version is available and it is possible to have cable connected at works and the terminals potted. Two spacers are included to separate the electrodes. For use at normal atmospheric pressure and temperatures between -20°C and +60°C not suitable for aggressive liquids which attack polypropylene.

For ordering purposes, the head and electrodes are ordered separately. When ordering please specify-

- 1) E14/N - Where N = No of electrodes 2, 3 or 4
- 2) 'L' = Length of electrodes below shoulder in mm
- 3) E14 electrode holders are normally supplied as fully made up assemblies c/w electrodes fitted. If you would prefer us not to fit the electrodes please advise when ordering.
- 4) Additional pairs of spacers/separators are available if required Type Ref 216.

ATEX APPROVED models available for use with P7/IS level controller. (Type Ref – 1GOHPE14/I.S )

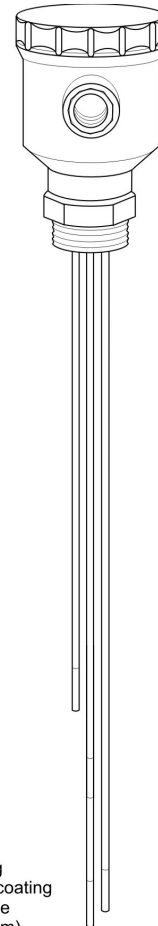

When installing bare back the coating on the electrode (Minimum 50mm)

Material - Coating	Order Ref	Dia	Max Length	Coating Colour
S/Steel 316L- Epoxy Thermomelt Coated	176	3.2mm	1m	Black
S/Steel 316L- Epoxy Fusion Bond Coated	219	3.2mm	1m	Aqua Green
Titanium - Epoxy Thermomelt Coated	207	3.2mm	1m	Blue
Hastelloy – Uncoated/Bare	220	3.2mm	880mm	None

Other coatings are available to special order. An additional Type 71/Stainless Steel 304/316L grade mounting bracket is available. The electrodes are push to fit into body, which should be warmed to approximately 80°C to facilitate or removal.

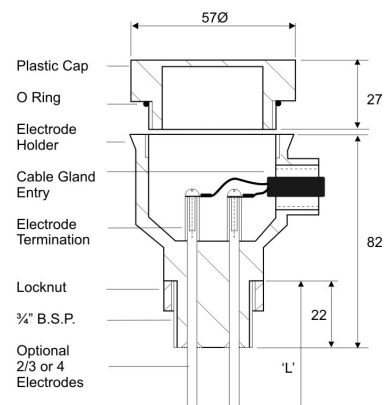

*This product has been designed and complies to the relevant standards as listed in its certificate of conformity. The installer/user must ensure compliance. The crossed out bin symbol, placed on the product, reminds you of the need to dispose of the product correctly at the end of its life. Because of continuing development we reserve the right to change the specifications without notice*

### HAWKER ELECTRONICS LTD.

57 The Avenue,  
 Rubery Industrial Estate,  
 Birmingham B45 9AL, ENGLAND  
 Telephone: +44 (0)121-453-8911 Fax: +44(0)121-453-3777  
 email: info@hawker-electronics.co.uk www.hawker-electronics.co.uk



FM 10000



BRITISH MADE