

WIRING INFORMATION
P1 TX+
P2 RX+
P3 TX-
P4 RX-

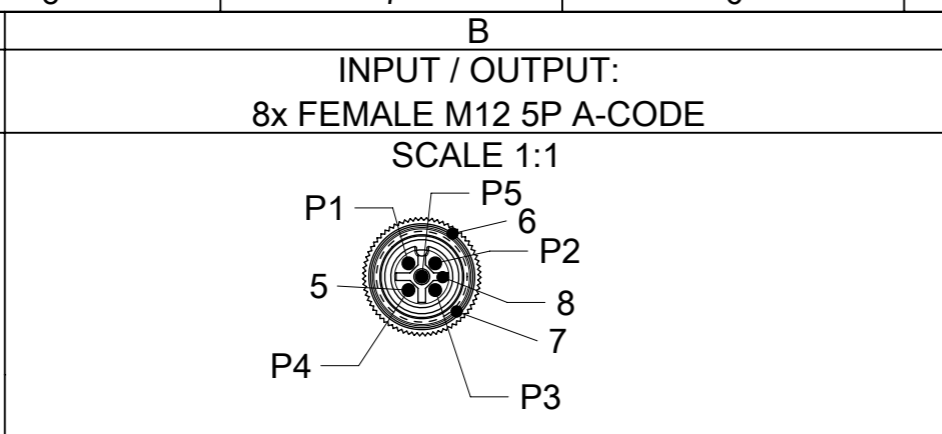

WIRING INFORMATION INPUT
P1 - +24 VDC
P2 - Input (even)
P3 - 0 V (Ground)
P4 - Input (odd)
P5 - PE (Protected Earth)

WIRING INFORMATION OUTPUT
P1 - N/C
P2 - Output (even)
P3 - 0 V (Ground)
P4 - Output (odd)
P5 - PE (Protected Earth)

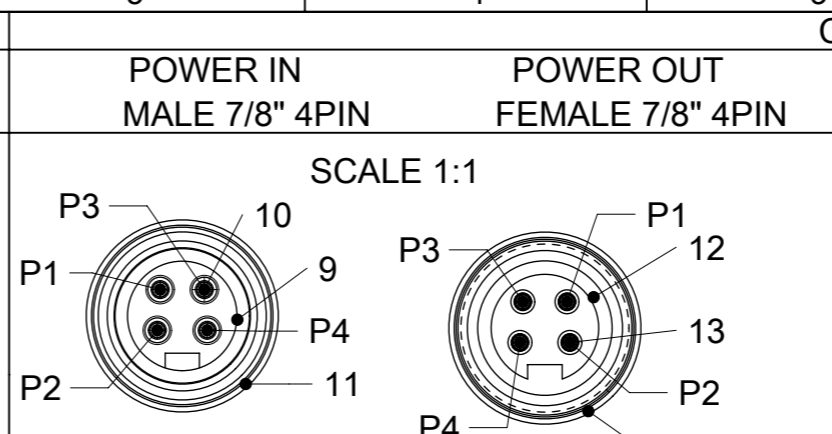

WIRING INFORMATION
P1 - +24 VDC (Outputs Power)
P2 - +24 VDC (Module & Inputs Power)
P3 - 0 V (Module & Inputs Power)
P4 - 0 V (Outputs Power)

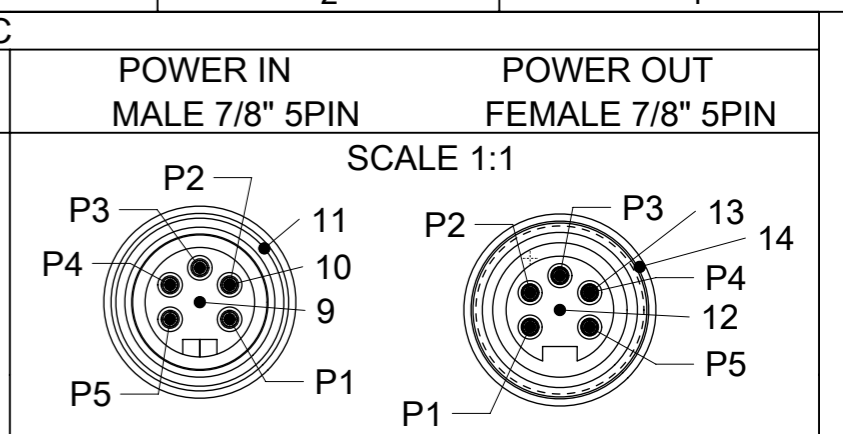

WIRING INFORMATION
P1 - 0 V (Outputs Power)
P2 - 0 V (Module & Inputs Power)
P3 - PE (Protected Earth)
P4 - +24 VDC (Module and Inputs Power)
P5 - +24 VDC (Outputs Power)

BILL OF MATERIAL

ITEM	DESCRIPTION	MATERIAL	FINISH
1	INSERT	TPU	BLACK
2	CONTACT	COPPER ALLOY	GOLD OVERNICKEL
3	SHELL	BRASS	NICKEL PLATET
4	GASKET	FPM	RED
5	CONTACT	COPPER ALLOY	GOLD OVER NICKEL
6	GASKET	FPM	RED
7	SHELL	BRASS	NICKEL PLATET
8	INSERT	TPU	BLACK
9	INSERT	TPE	YELLOW
10	CONTACT	COPPER ALLOY	GOLD OVERNICKEL
11	SHELL	BRASS	NICKEL PLATET
12	INSERT	TPE	YELLOW
13	CONTACT	COPPER ALLOY	GOLD OVER NICKEL
14	SHELL	BRASS	NICKEL PLATET
15	WINDOW	PC	TRANSPARENT
16	SCREW	V2A	-
17	LABEL	PC	WHITE
18	FIBER OPTIC	PA	TRANSPARENT
19	WASHER	BRASS	NICKEL PLATET
20	SCREW	V2A	-
21	SHIELD PLATE	STAINLESS STEEL	-
22	RESIN	EPOXY	TRANSPARENT
23	LABEL	PVC	WHITE
24	HOUSING	PBT	BLACK
25	LABEL	PVC	YELLOW

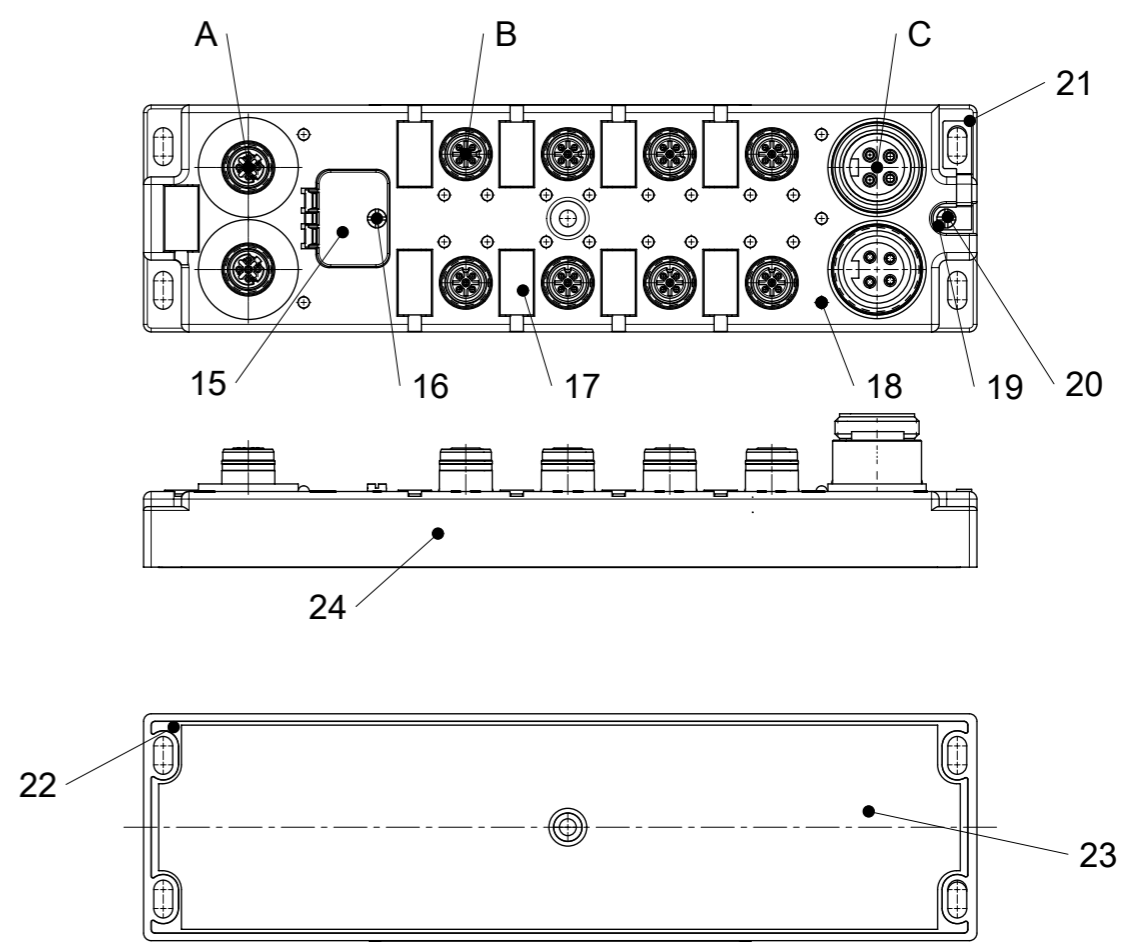
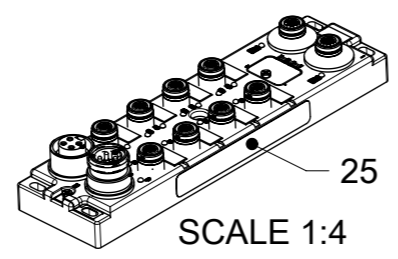

SYMBOLS DIMENSION UNITS: mm SCALE: 1:2 GENERAL TOLERANCES (UNLESS SPECIFIED): ANGULAR TOL: ± ° 4 PLACES: ± 3 PLACES: ± 2 PLACES: ± 1 PLACE: ± 0.3 0 PLACES: ± 0.5 DRAFT WHERE APPLICABLE MUST REMAIN WITHIN DIMENSIONS THIRD ANGLE PROJECTION	THIS DRAWING CONTAINS INFORMATION THAT IS PROPRIETARY TO MOLEX ELECTRONIC TECHNOLOGIES, LLC AND SHOULD NOT BE USED WITHOUT WRITTEN PERMISSION CURRENT REV DESC: ADD NEW P/N'S	
	EC NO: 171585 DRWN: RSCHIEBER 2018/01/22 CHK'D: ULETTENMEIER 2018/02/01 APPR: RSILLER 2018/02/05	
INITIAL REVISION: DRWN: ULETTENMEIER 2015/01/19 APPR: JALEXANDER 2015/06/25		PRODUCT CUSTOMER DRAWING DOCUMENT NUMBER: 1120950007 DOC TYPE: PSD DOC PART: 000 REVISION: B
MATERIAL NUMBER: 112095 CUSTOMER: GENERAL MARKET		SHEET NUMBER: 2 OF 8

TABLE 1 UNIVERSAL PRINTING

POWER TYPE	INPUT / OUTPUT	MODBUS TCP		EtherNet/IP		PROFINET		3D MODEL NO.	
		ENG.NO.	MOLEX P/N	ENG.NO.	MOLEX P/N	ENG.NO.	MOLEX P/N		
7/8" 5 POLE	NPN	16I	TCDEM-8D0N-D1U	1120950007	TCDEI-8D0N-D1U	1120955003	TCDEP-8D0N-D1U	1120955029	1120950007 (PDM)
		14I / 2O	TCDEM-8C2N-D1U	1120950005	TCDEI-8C2N-D1U	1120955004	TCDEP-8C2N-D1U	1120955030	
		12I / 4O	TCDEM-8B4N-D1U	1120950003	TCDEI-8B4N-D1U	1120955005	TCDEP-8B4N-D1U	1120955031	
		8I / 8O	TCDEM-888N-D1U	1120950001	TCDEI-888N-D1U	1120955006	TCDEP-888N-D1U	1120955032	
	16 USER CONFIG.	TCDEM-8YYX-D1U	1120950009	TCDEI-8YYX-D1U	1120955011	TCDEP-8YYX-D1U	1120955037		
	USER CONFIG.			TCDEI-8YYX-DYU-02	1120955117				
	PNP	16I	TCDEM-8D0P-D1U	1120950008	TCDEI-8D0P-D1U	1120955007	TCDEP-8D0P-D1U	1120955033	
		14I / 2O	TCDEM-8C2P-D1U	1120950006	TCDEI-8C2P-D1U	1120955008	TCDEP-8C2P-D1U	1120955034	
		12I / 4O	TCDEM-8B4P-D1U	1120950004	TCDEI-8B4P-D1U	1120955009	TCDEP-8B4P-D1U	1120955035	
		8I / 8O	TCDEM-888P-D1U	1120950002	TCDEI-888P-D1U	1120955010	TCDEP-888P-D1U	1120955036	
7/8" 4 POLE	NPN	16I	TCDEM-8D0N-DYU	1120955021	TCDEI-8D0N-DYU	1120955012			1120950007 (PDM)
		14I / 2O	TCDEM-8C2N-DYU	1120955022	TCDEI-8C2N-DYU	1120955013			
		12I / 4O	TCDEM-8B4N-DYU	1120955023	TCDEI-8B4N-DYU	1120955014			
		8I / 8O	TCDEM-888N-DYU	1120955024	TCDEI-888N-DYU	1120955015			
	16 USER CONFIG.	TCDEM-8YYX-DYU	1120955038	TCDEI-8YYX-DYU	1120955020				
	USER CONFIG.			TCDEI-8YYX-DYU-02	1120955116				
	PNP	16I	TCDEM-8D0P-DYU	1120955025	TCDEI-8D0P-DYU	1120955016			
		14I / 2O	TCDEM-8C2P-DYU	1120955026	TCDEI-8C2P-DYU	1120955017			
		12I / 4O	TCDEM-8B4P-DYU	1120955027	TCDEI-8B4P-DYU	1120955018			
		8I / 8O	TCDEM-888P-DYU	1120955028	TCDEI-888P-DYU	1120955019			

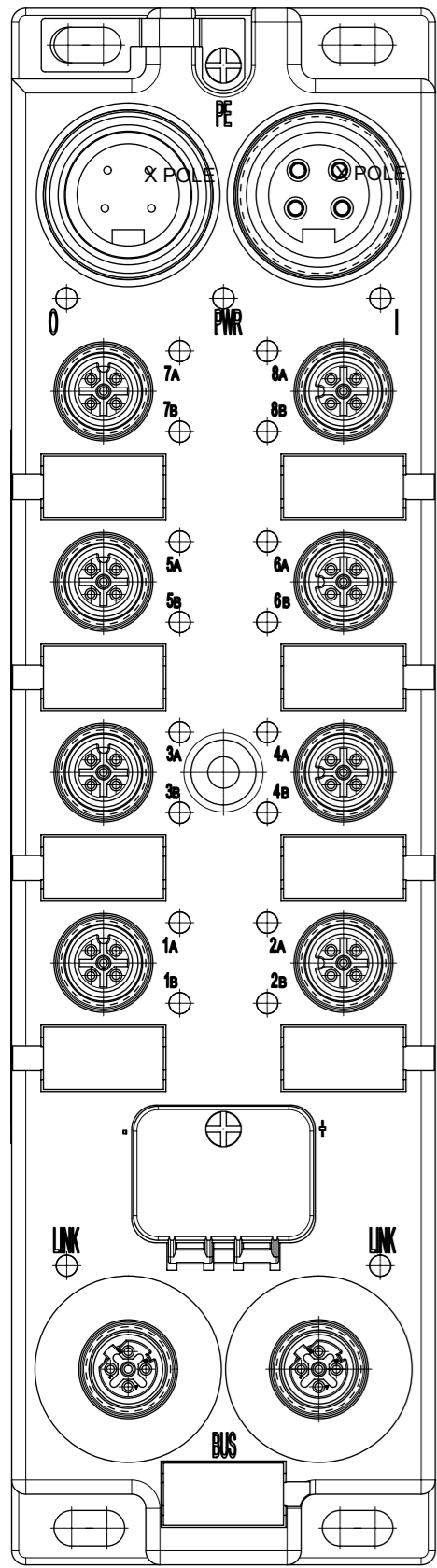

UNIVERSAL PRINTING

SYMBOLS	THIS DRAWING CONTAINS INFORMATION THAT IS PROPRIETARY TO MOLEX ELECTRONIC TECHNOLOGIES, LLC AND SHOULD NOT BE USED WITHOUT WRITTEN PERMISSION		CURRENT REV DESC: ADD NEW P/N'S		molex
	DIMENSION UNITS	SCALE			
▽ = 0	mm	1:1			DBO ETH 60 MM 7/8" 4P/5P AC MA FE U12 5P U12 4P 2PT DC FE
▽ = 0	GENERAL TOLERANCES (UNLESS SPECIFIED)				
▽ = 0	ANGULAR TOL ± °				PRODUCT CUSTOMER DRAWING
▽ = 0	4 PLACES ±				
▽ = 0	3 PLACES ±				DOCUMENT NUMBER: 1120950007 DOC TYPE: PSD DOC PART: 000 REVISION: B
▽ = 0	2 PLACES ±				
▽ = 0	1 PLACE ± 0.3				INITIAL REVISION: DRWN: ULETENMEIER 2015/01/19 APPR: JALEXANDER 2015/06/25
▽ = 0	0 PLACES ± 0.5				
■ = 0	DRAFT WHERE APPLICABLE MUST REMAIN WITHIN DIMENSIONS		THIRD ANGLE PROJECTION	DRAWING	SERIES
▽ = 0				A3-SIZE	112095
MATERIAL NUMBER: SEE TABLE 1,2,3,4,5,6			CUSTOMER: GENERAL MARKET		SHEET NUMBER: 3 OF 8

TABLE 3 8I/8O PRINTING

POWER TYPE	INPUT/OUTPUT	EtherNet/IP		PROFINET		3D MODEL NO.	
		ENG. NO	MOLEX P/N	ENG. NO	MOLEX P/N		
7/8" 5 POLE	PNP	8I/8O	TCDEI-888P-D1U-G	1120955061	TCDEP-888P-D1U-G	1120955050	1120950007 (PDM)
		8I/8O	TCDEI-888P-D1U-G02	1120955142			
		8IN/4M	TCDEI-88MP-D1U-G	1120955118			
7/8" 4 POLE	PNP	8I/8O	TCDEI-888P-DYU-G	1120955041	TCDEP-888P-DYU-G	1120955053	1120950007 (PDM)
			TCDEI-888P-DYU-G01	1120955072			
			TCDEI-888P-DYU-G02	1120955138			

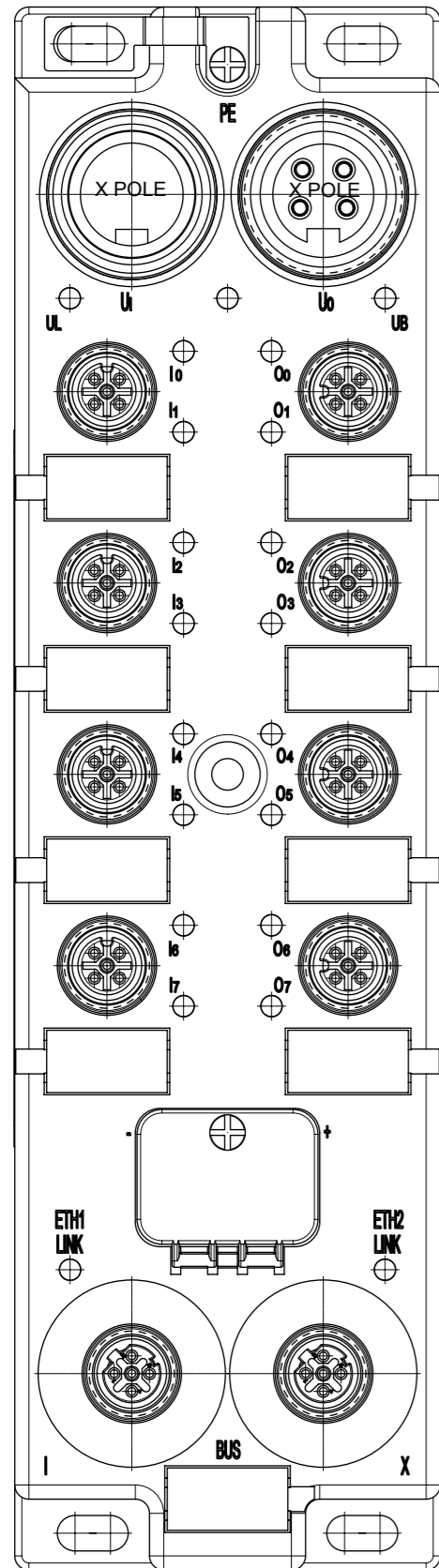

8I/8O IN PRINTING

SYMBOLS	THIS DRAWING CONTAINS INFORMATION THAT IS PROPRIETARY TO MOLEX ELECTRONIC TECHNOLOGIES, LLC AND SHOULD NOT BE USED WITHOUT WRITTEN PERMISSION		CURRENT REV DESC: ADD NEW P/N'S		molex	
	DIMENSION UNITS	SCALE				DBO ETH 60 MM 7/8" 4P/5P AC MA FE U12 5P U12 4P 2PT DC FE
▽ = 0	mm	1:1			PRODUCT CUSTOMER DRAWING	
▽ = 0	GENERAL TOLERANCES (UNLESS SPECIFIED)					
▽ = 0	ANGULAR TOL ± °				DOCUMENT NUMBER	
▽ = 0	4 PLACES ±		EC NO: 171585			
▽ = 0	3 PLACES ±		DRWN: RSCHIEBER 2018/01/22		1120950007	
▽ = 0	2 PLACES ±		CHK'D: ULETTENMEIER 2018/02/01			
▽ = 0	1 PLACE ± 0.3		APPR: RSILLER 2018/02/05		DOC TYPE	
▽ = 0	0 PLACES ± 0.5		INITIAL REVISION:			DOC PART
☒ = 0	DRAFT WHERE APPLICABLE MUST REMAIN WITHIN DIMENSIONS		DRWN: ULETTENMEIER 2015/01/19		REVISION	
☒ = 0			APPR: JALEXANDER 2015/06/25			B
☒ = 0			THIRD ANGLE PROJECTION	DRAWING	SHEET NUMBER	
☒ = 0				A3-SIZE		5 OF 8
		SERIES	MATERIAL NUMBER	CUSTOMER		
		112095	SEE TABLE 1,2,3,4,5,6	GENERAL MARKET		

TABLE 4 12I/4O PRINTING

POWER TYPE	INPUT/OUTPUT	EtherNet/IP		PROFINET		3D MODEL NO.	
		ENG. NO	MOLEX P/N	ENG. NO	MOLEX P/N		
7/8" 5 POLE	PNP	12I/4O	TCDEI-8B4P-D1U-G	1120955063	TCDEP-8B4P-D1U-G	1120955051	1120950007 (PDM)
		12I/4O	TCDEI-8B4P-D1U-G02	1120955143			
7/8" 4 POLE	PNP	12I/4O	TCDEI-8B4P-DYU-G	1120955043	TCDEP-8B4P-DYU-G	1120955054	1120950007 (PDM)
		12I/4O	TCDEI-8B4P-DYU-G01	1120955073			
		12I/4O	TCDEI-8B4P-DYU-G02	1120955139			

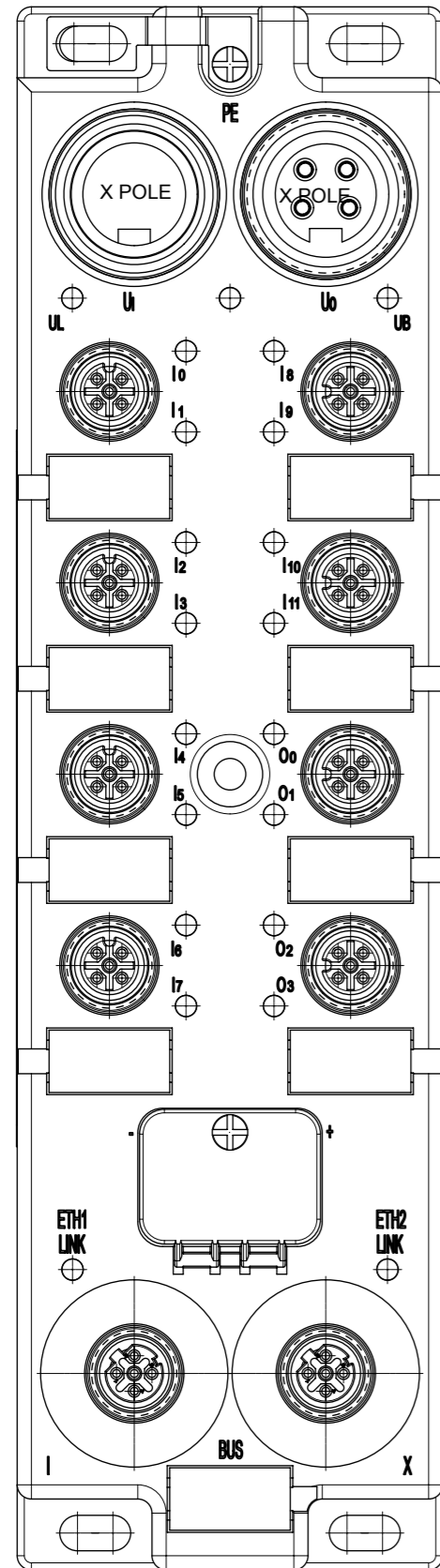

12I/4O PRINTING

SYMBOLS	THIS DRAWING CONTAINS INFORMATION THAT IS PROPRIETARY TO MOLEX ELECTRONIC TECHNOLOGIES, LLC AND SHOULD NOT BE USED WITHOUT WRITTEN PERMISSION		CURRENT REV DESC: ADD NEW P/N'S				
	DIMENSION UNITS	SCALE					
▽ = 0	mm	1:1	1120950007	PSD	000	B	
▽ = 0	GENERAL TOLERANCES (UNLESS SPECIFIED)		EC NO: 171585		DRW: RSCHIEBER 2018/01/22		
▽ = 0	ANGULAR TOL ± °		CHK'D: ULETTENMEIER 2018/02/01		APPR: RSILLER 2018/02/05		
▽ = 0	4 PLACES ±		INITIAL REVISION:		DRWN: ULETTENMEIER 2015/01/19		
▽ = 0	3 PLACES ±		DRWN: ULETTENMEIER 2015/01/19		APPR: JALEXANDER 2015/06/25		
▽ = 0	2 PLACES ±		DRAFT WHERE APPLICABLE MUST REMAIN WITHIN DIMENSIONS		THIRD ANGLE PROJECTION		
▽ = 0	1 PLACE ± 0.3		DRAWING		SERIES		
▽ = 0	0 PLACES ± 0.5		A3-SIZE		112095		
■ = 0	DRAFT WHERE APPLICABLE MUST REMAIN WITHIN DIMENSIONS		MATERIAL NUMBER		CUSTOMER		
▽ = 0			SEE TABLE 1,2,3,4,5,6		GENERAL MARKET		
						SHEET NUMBER	
						6 OF 8	

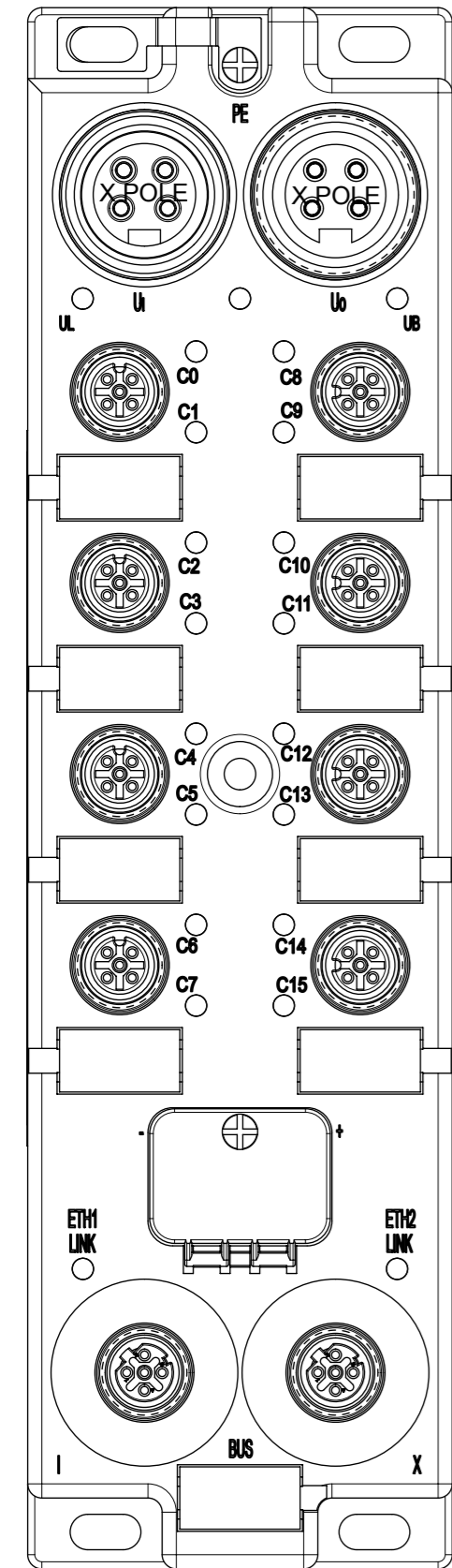
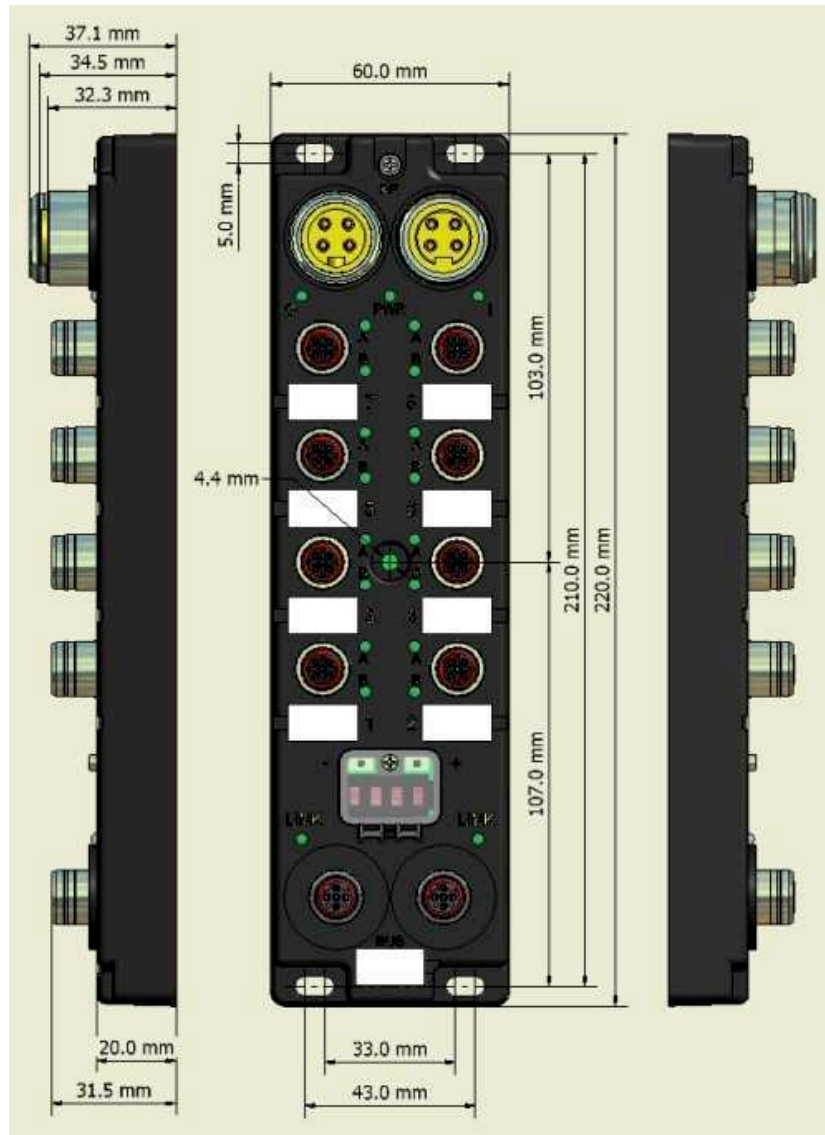

TABLE 6 16 USER CONFIG PRINTING

POWER TYPE	INPUT/OUTPUT		EtherNet/IP		PROFINET		3D MODEL NO.
			ENG. NO	MOLEX P/N	ENG. NO	MOLEX P/N	
7/8" 5 POLE	PNP	USER CONFIG	TCDEI-8YYX-D1U-G02	1120955117	TCDEP-8YYX-D1U-01	1120955115	1120950007 (PDM)
7/8" 4 POLE			TCDEI-8YYX-DYU-G02	1120955116	TCDEP-8YYX-DYU-01	1120955114	

SYMBOLS	THIS DRAWING CONTAINS INFORMATION THAT IS PROPRIETARY TO MOLEX ELECTRONIC TECHNOLOGIES, LLC AND SHOULD NOT BE USED WITHOUT WRITTEN PERMISSION		CURRENT REV DESC: ADD NEW P/N'S		molex
	DIMENSION UNITS	SCALE			
▽ = 0	mm	1:1			DBO ETH 60 MM 7/8" 4P/5P AC MA FE U12 5P U12 4P 2PT DC FE
▽ = 0	GENERAL TOLERANCES (UNLESS SPECIFIED)				
▽ = 0	ANGULAR TOL ± °				PRODUCT CUSTOMER DRAWING
▽ = 0	4 PLACES ±		EC NO: 171585		
▽ = 0	3 PLACES ±		DRWN: RSCHIEBER 2018/01/22		
▽ = 0	2 PLACES ±		CHK'D: ULETTENMEIER 2018/02/01		
▽ = 0	1 PLACE ±	0.3	APPR: RSILLER 2018/02/05		
▽ = 0	0 PLACES ±	0.5	INITIAL REVISION:		
☒ = 0	DRAFT WHERE APPLICABLE MUST REMAIN WITHIN DIMENSIONS		THIRD ANGLE PROJECTION	DRAWING	SERIES
▽ = 0				A3-SIZE	112095
			MATERIAL NUMBER	CUSTOMER	SHEET NUMBER
			1120950007	GENERAL MARKET	8 OF 8



Part Number	Description
TCDEM-8D0N-DYU	IO:MDB/TCP:IP67:60MM:8P4:16DI:NPN
TCDEM-8C2N-DYU	IO:MDB/TCP:IP67:60MM:8P4:14DI/2DO:NPN
TCDEM-8B4N-DYU	IO:MDB/TCP:IP67:60MM:8P4:12DI/4DO:NPN
TCDEM-888N-DYU	IO:MDB/TCP:IP67:60MM:8P4:8DI/8DO:NPN
TCDEM-8D0P-DYU	IO:MDB/TCP:IP67:60MM:8P4:16DI:PNP
TCDEM-8C2P-DYU	IO:MDB/TCP:IP67:60MM:8P4:14DI/2DO:PNP
TCDEM-8B4P-DYU	IO:MDB/TCP:IP67:60MM:8P4:12DI/4DO:PNP
TCDEM-888P-DYU	IO:MDB/TCP:IP67:60MM:8P4:8DI/8DO:PNP
TCDEM-8YYX-DYU	IO:MDB/TCP:IP67:60MM:8P4:16 DCONFIG

REVISION: A	ECR/ECN INFORMATION: EC No: NA DATE: 2010/02 /01	TITLE: Modbus TCP IO Block IP67 60MM M12 8 Ports with Power connector 4 Poles	SHEET No. 1 of 1
DOCUMENT NUMBER: SD-112095-5021	CREATED / REVISED BY: SZOUTARD	CHECKED BY: SMENARD	APPROVED BY: SZOUTARD



The BradControl™ IP67 I/O modules provide a reliable solution for connecting industrial controllers to I/O devices in harsh environments.

24 Mar. 10
DW2007208

HarshIO 600 eMB

MODBUS TCP

IP67 Modbus TCP I/O block



Features

- Supports Modbus TCP (TCP/IP & UDP)
- Accepts M12 threaded connectors or BradConnectivity™ Ultra-Lock™ connection system
- Standard hole pattern allows for interchangeability with popular I/O modules
- Supports PNP & NPN input devices
- Several I/O configurations to choose from
 - TCDEM-8YYX-DIU offers 16 points of configurable I/O where the user can configure each point as either an input, output or input/output
- Visible LEDs provide maintenance personnel with the ability to easily determine I/O, module & network status
- Rated IP67 for harsh environments
- Designed for direct machine mount applications
- IP addressing via Bootp, DHCP or static (through web interface, push button & Modbus commands)
- Scrolling 4 characters status display for IP addressing and module status
- Built-in 3-port Ethernet switch
 - 10/100 Mbps auto-sensing and crossover capability
- Built-in web server for remote monitoring, configuration and diagnostics
- Configurable I/O capability (through web interface & Modbus commands)
- Watchdog

I/O Systems for Harsh Duty Environments

BradControl™ Modbus I/O modules provide a reliable solution for connecting industrial controllers to I/O devices in harsh duty environments.

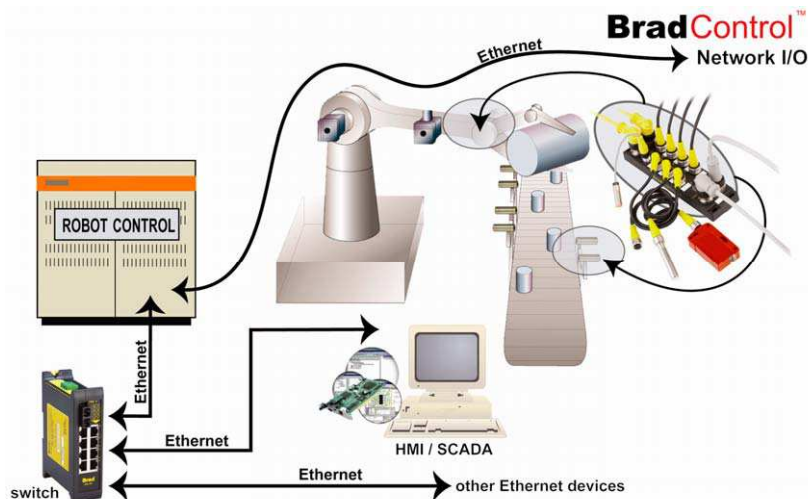

Contained in an IP67 rated housing, BradControl I/O modules can be machine mounted and are able to withstand areas where liquids, dust or vibration may be present. This makes them ideally suited for many applications including material handling equipment and automated assembly machinery.

Advanced network features such as 10/100 Mbps auto-sensing, web server capabilities and a flexible IP address setup method, make configuration and operation simple. Following traditional industrial fieldbus practices, standard M12 connectors from sensing devices or actuators plug directly into the I/O module. An environmentally sealed IP67 connection between the I/O module and the Ethernet network is created using the Ultra-Lock™ connection system built into the BradControl Ethernet I/O module.

HarshIO 600 eMB



LED Indicators

Module & Input Power (I):

Green –power present
Off –power not connected

Output Power (O):

Green –power present
Off –power not connected

Display Box:

Inform about Ethernet address, I/O and Watchdog status

Input / Output (Ix / OX):

Green – input/output on
Red – input/output fault
Off – input/output off

Ethernet Link (LNK 1/2):

Solid Green – Ethernet link at 100 Mbit/s without activity.

Flashing Green – Ethernet link at 100 Mbit/s with activity.

Solid Yellow – Ethernet link at 10 Mbit/s without activity.

Flashing Yellow – Ethernet link at 10 Mbit/s with activity.

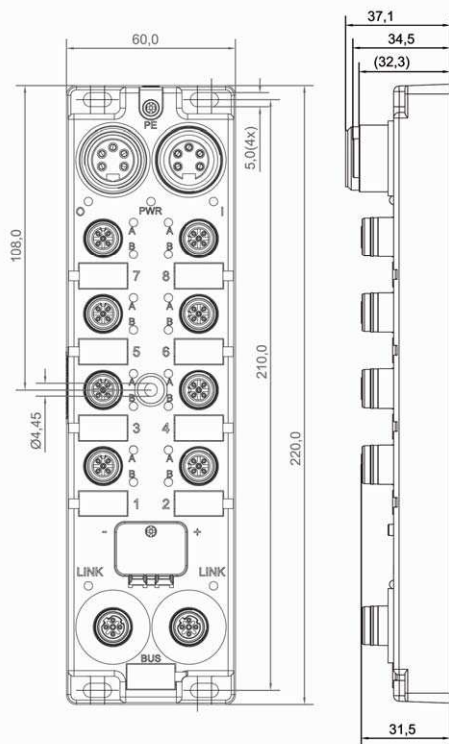

Technical Information

I/O Configurations	16 inputs 14 inputs / 2 outputs 12 inputs / 4 outputs 8 inputs / 8 outputs 16 Universal & user configurable input / output channels
I/O Connectors	Micro-Change [®] 5-pole M12 female BradConnectivity [™] Ultra-Lock [™] , internally threaded
Ethernet Connectors	2 connectors 4-pole female M12 D-Coded Ultra-Lock Acting as a switch. Crossover capability
Power Connectors	Power in : male Mini-Change 4-pole or 5-pole Power out : female Mini-Change 4-pole or 5-pole
Power Requirements	Module & input power : 24 Vdc, Module output power : 24 Vdc (13 ↔ 28 V), 8A max per bloc
Communications Rate	10/100 Mbps auto-sensing, auto-detecting, full duplex
IP Address Capabilities	BOOTP (default), DHCP, static address
Protocol	Modbus (TCP & UDP) Function code: 01, 02, 03, 04, 05, 06, 15, 16, 23
Input Type	Compatible with dry contact and PNP or NPN 3-wire switches. Electronic short circuit protection
Input Delay	2.5 ms default or Configurable through Modbus messaging
Input Device Supply	200 mA per port at 25°C
Output Load Current	Maximum 2.0 A per channel Electronic short circuit protection
Max. Switching Freq.	200 Hz
Housing Dimensions	60mm x 220mm x 20mm (2.36 x 8.66 x .78 inches)
Mounting Dimensions	37.5 mm (1.48 inches) horizontal on centers 210 mm (8.27 inches) vertical on centers Center hole
Operating Temperature	-20°C to 70°C (-4°F to 158°F)
Storage Temperature	-40°C to 85°C (-40°F to 185°F)
Protection	IP67 according to IEC 60529
Vibration	IEC 60068-2-6
Mechanical Shock	10G, 11ms, 3 axis
Approvals	CE, UL, cUL

Ordering Information

	Part Number	SAP number	Product Description
4-pin Power	TCDEM-8D0N-DYU	112095-5021	8-port, M12 Ultra-Lock, 16 input, NPN
	TCDEM-8C2N-DYU	112095-5022	8-port, M12 Ultra-Lock, 14 input, 2 output, NPN
	TCDEM-8B4N-DYU	112095-5023	8-port, M12 Ultra-Lock, 12 input, 4 output, NPN
	TCDEM-888N-DYU	112095-5024	8-port, M12 Ultra-Lock, 8 input, 8 output, NPN
	TCDEM-8D0P-DYU	112095-5025	8-port, M12 Ultra-Lock, 16 input, PNP
	TCDEM-8C2P-DYU	112095-5026	8-port, M12 Ultra-Lock, 14 input, 2 output, PNP
	TCDEM-8B4P-DYU	112095-5027	8-port, M12 Ultra-Lock, 12 input, 4 output, PNP
	TCDEM-888P-DYU	112095-5028	8-port, M12 Ultra-Lock, 8 input, 8 output, PNP
	TCDEM-8YXX-DYU	112095-5038	8-port, M12 Ultra-Lock, 16 I/O user configurable
5-pin Power	TCDEM-8D0N-D1U	112095-0007	8-port, M12 Ultra-Lock, 16 input, NPN
	TCDEM-8C2N-D1U	112095-0005	8-port, M12 Ultra-Lock, 14 input, 2 output, NPN
	TCDEM-8B4N-D1U	112095-0003	8-port, M12 Ultra-Lock, 12 input, 4 output, NPN
	TCDEM-888N-D1U	112095-0001	8-port, M12 Ultra-Lock, 8 input, 8 output, NPN
	TCDEM-8D0P-D1U	112095-0008	8-port, M12 Ultra-Lock, 16 input, PNP
	TCDEM-8C2P-D1U	112095-0006	8-port, M12 Ultra-Lock, 14 input, 2 output, PNP
	TCDEM-8B4P-D1U	112095-0004	8-port, M12 Ultra-Lock, 12 input, 4 output, PNP
	TCDEM-888P-D1U	112095-0002	8-port, M12 Ultra-Lock, 8 input, 8 output, PNP
	TCDEM-8YXX-D1U	112095-0009	8-port, M12 Ultra-Lock, 16 I/O user configurable

To contact us: www.woodhead.com

North America: US: +1-800-225-7724 – Canada: +1 (905) 624-6518

Europe: France: +33 (0)1 64 30 91 36 – Germany: +49 7252/94 96-0 – Italy: +39 026-6400321
United Kingdom: +44 1495 356300

Asia: Shanghai, China: +86 21-5835-9885 - Tianjin, China: +86 22-23321717
Singapore: +65 6268-6868 – Yamato, Japan: +81 46-265-2428 – Nagoya, Japan: +81 52-221-5950

Micro-Change & Mini-Change are registered trademarks and BradControl, BradConnectivity and Ultra-Lock are trademarks of Molex Incorporated. © 2007 Molex

Brad[®]
from **molex**