



Safety sensor 165

The 165 series stainless steel safety sensors are flexible in use thanks to their robust housing design.

The polished stainless steel housing, high IP69K protection class and the high temperature resistance of up to +80 °C make this ideal for use in hygienic or wet areas of a machine or system. Almost unrivalled robustness!

Technical specifications

- Food-safe cable allows installation in the process zone
- Simple diagnosis through optional control contact
- IP6K9K protection class (DIN 40050-9)

Technical drawing

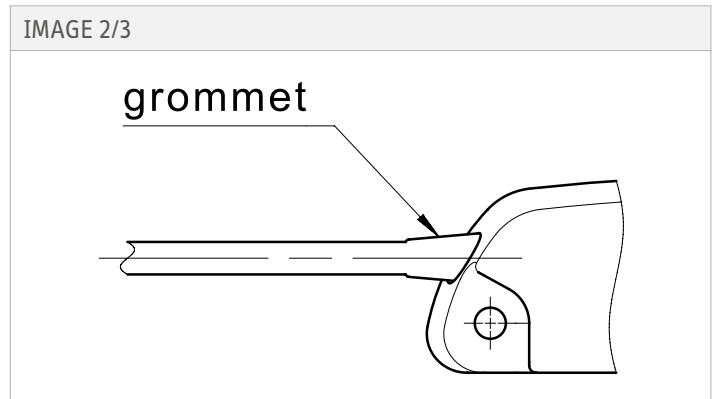
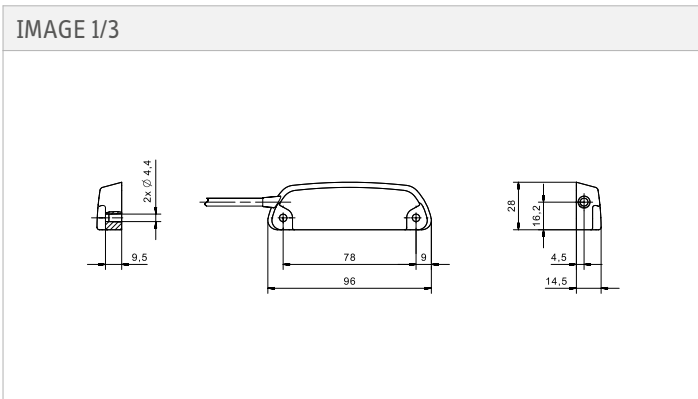
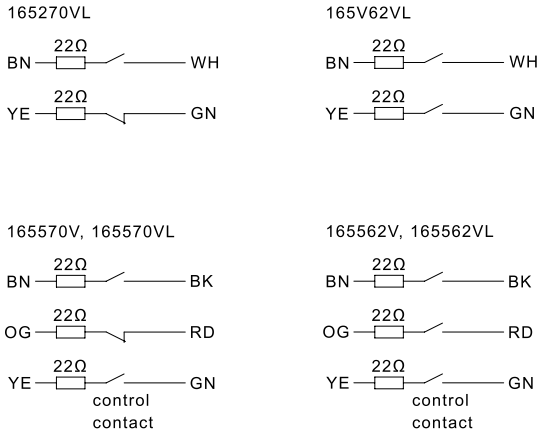
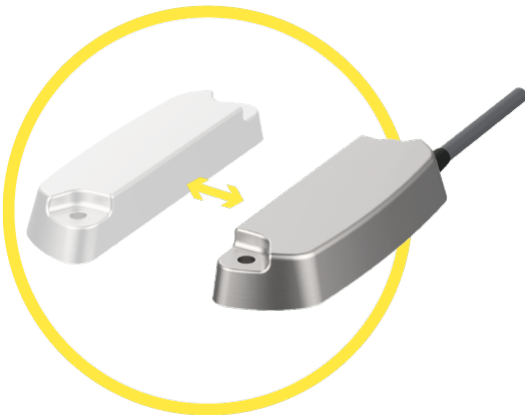

IMAGE 3/3



Product options

IMAGE 1/3



Assured switching distance (Sao) of 4 mm with standard actuators, 7 mm with extended-range actuators. Assured switch-off distance (Sar) of up to 16 mm with standard actuators, up to 23 mm with extended-range actuators.

IMAGE 2/3

ORDERING KEY

	165V62VL	165270VL	165562V
Cubic stainless steel housing, hygienic version	x	x	x
Increased temperature range (100 °C)	-	-	x
Connection cable 1m 1	x	x	x
Food-safe cable, UL- and FDA-approved	x	x	-
N.O./N.C. contacts	x	-	x
N.O./N.C. contacts	-	x	-
Additional N.O. control contact	-	-	x
Coded	x	x	x
Uncoded	-	-	-

	165562VL	165570V	165570VL
Cubic stainless steel housing, hygienic version	x	x	x
Increased temperature range (100 °C)	-	x	-
Connection cable 1m 1	x	x	x
Food-safe cable, UL- and FDA-approved	x	-	x
N.O./N.C. contacts	x	-	-
N.O./N.C. contacts	-	x	x
Additional N.O. control contact	x	x	x
Coded	x	x	x
Uncoded	-	-	-

* Other cable lengths, cable materials and connector types on request

IMAGE 3/3

MATCHING ACTUATORS

Actuators	Actuation direction	165V62VL			165279VL			165562V		
		S ₀	S ₁	S ₂	S ₀	S ₁	S ₂	S ₀	S ₁	S ₂
304 281 12 V	Front	0.5	4	16	0.5	4	16	0.5	5	16
304 281 12 VS		3	7	18	3	7	23	0.5	7	20

Actuators	Actuation direction	165562VL			165570V			165570VL		
		S ₀	S ₁	S ₂	S ₀	S ₁	S ₂	S ₀	S ₁	S ₂
304 281 12 V	Front	0.5	5	16	0.5	4	17	0.5	4	17
304 281 12 VS		0.5	7	20	0.5	6	21	0.5	6	21

S₀ = minimum switching distance (mm), S₁ = operating distance (mm), S₂ = assured switch-off distance (mm)