

Section 5: Serial Bus Transmitter & Expansion Cables

This chapter describes the serial expansion module and expansions cables for PACSystems RX3i controllers. It also gives specifications for building custom expansion cables.

Description	Catalog Number	Section
Serial Bus Transmitter Module	IC695LRE001	5.1
Expansion Cable, Wye, 1m (3 ft) Length	IC693CBL300	5.2.2
Expansion Cable, Wye, 2m (6 ft)	IC693CBL301	5.2.2
Expansion Cable, 2 Connectors, Built-in Terminating Resistor, 15m (50 ft)	IC693CBL302	5.2.1
Expansion Cable, Wye, 0.15m (0.5 ft)	IC693CBL312	5.2.2
Expansion Cable, Wye, 8m (25 ft)	IC693CBL313	5.2.2
Termination Resistor Pack	IC693ACC307	5.3.3

5.1 Serial Bus Transmitter Module: IC695LRE001

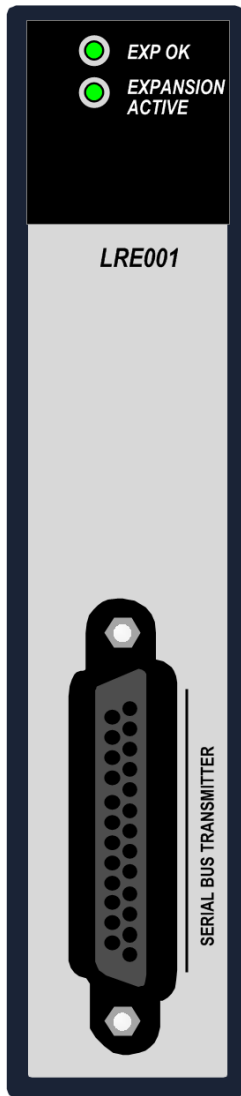

Figure 117: IC695LRE001

The RX3i Serial Bus Transmitter Module, IC695LRE001, provides communications between a PACSystems RX3i Universal Backplane (IC695-model number), and serial expansion and remote backplanes (IC694- or IC693-model numbers). It converts the signal levels present in the Universal Backplane to the signal levels required by a Serial Expansion Backplane.

The Serial Bus Transmitter Module must reside in the special expansion connector on the right end of the Universal Backplane.

Two green LEDs indicate the operating status of the module and the status of the expansion link.

- The EXP OK LED is lit when backplane 5Vdc power is applied to the module.
- The Expansion Active LED indicates the status of the expansion bus. This LED is ON when the Expansion module is communicating with expansion backplanes. It is OFF when they are not communicating.

The connector on the front of the module is used to attach the expansion cable.

5.1.1 Specifications: LRE001

Current Required from Backplane	5.0 Vdc: 132mA 3.3 Vdc: 0 mA
Maximum Total Expansion Cable Length	15 m (50 ft) – Expansion Backplanes 213 m (700 ft) – Remote Backplanes

Effective Data Rate	500 k Bytes per second if the expansion bus includes Remote backplanes
Electrical Isolation	Non-isolated differential communications

For product standards and general specifications, refer to *Appendix A*.

5.1.2 Expansion Module Installation

The Serial Bus Transmitter Module (LRE001) resides in the special expansion connector located on the right-hand end of the 12- or 16-slot RX3i Universal Backplane. It does not latch into the backplane. Secure LRE001 with the captive screws supplied (Figure 118).

This module may NOT be hot-inserted in the backplane; power must be removed before installing or removing the Expansion Module. In addition, the expansion cable may not be attached or removed while the expansion rack has power applied.

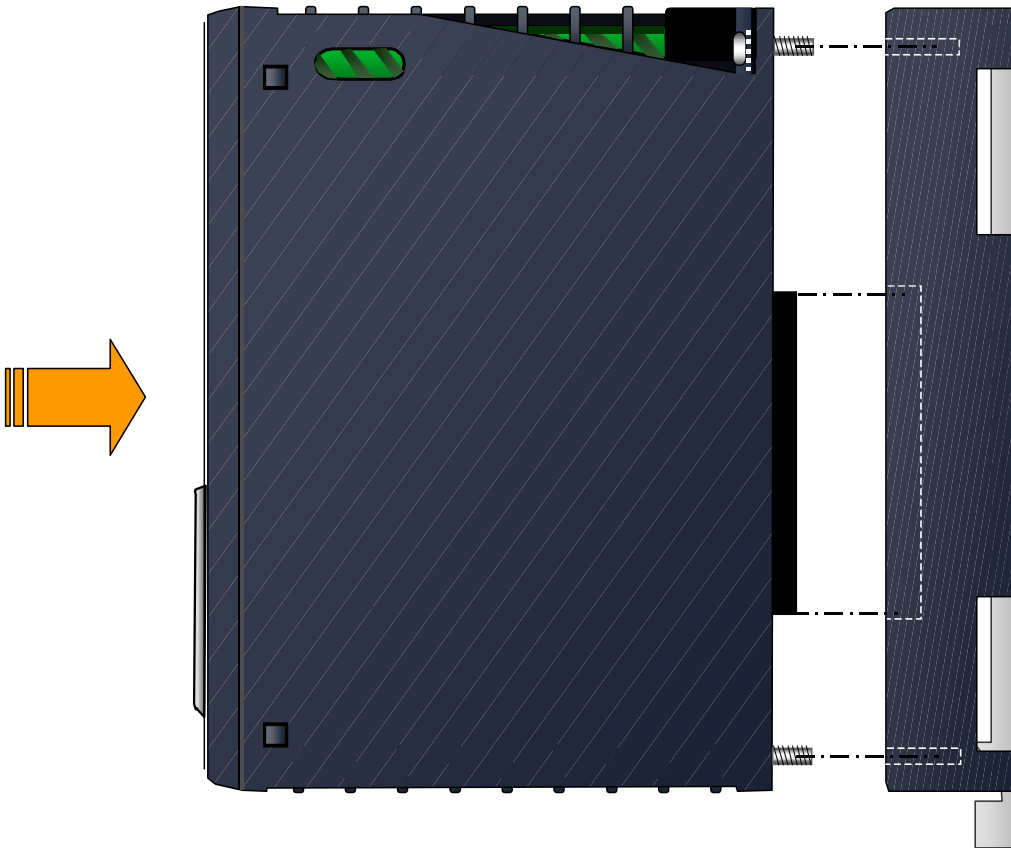

Figure 118: Install LRE001 in Rightmost Connector & Secure with Captive Screws

5.1.3 Powering Down Individual Expansion or Remote Backplanes

Expansion and Remote Backplanes can be powered down individually without affecting the operation of other backplanes; however, powering off a backplane generates a loss of module (LOSS_OF_MODULE) fault in the PLC Fault Table for each module in the backplane. When this fault condition occurs, and until the backplane is powered back on and all modules recovered, the lost I/O modules are not scanned.

5.2 I/O Bus Expansion Cables: IC693CBL300, 301, 302, 312, 313

I/O Bus Expansion Cables are used to connect a Serial Bus Transmitter Module, IC695LRE001, in a Universal Backplane (IC695CHS012 or IC695CHS016) to a Serial Expansion Backplane (IC694CHS392, IC694CHS398, IC693CHS392 or IC693CHS398).

These cables are also used to interconnect additional expansion and remote backplanes (as listed above) in the RX3i system.

Several lengths and configurations of prefabricated cables are available (part numbers IC693CBL300, IC693CBL301, IC693CBL302, IC693CBL312, and IC693CBL313), as described in this section.

The prefabricated cables described in this section are made with a *continuous*, 100% shield. The braided cable shield is connected to the metal shell of the connector around the entire perimeter of the connector. That provides a low-impedance path to frame ground for any noise energy that is coupled onto the cable shield.

5.2.1 Cable with Two Connectors: IC693CBL302

Cable IC693CBL302 (shown in Figure 119) is 15 meters (50 feet) long and has one male connector on each end. This cable has I/O bus terminating resistors built into the end connector on the cable.

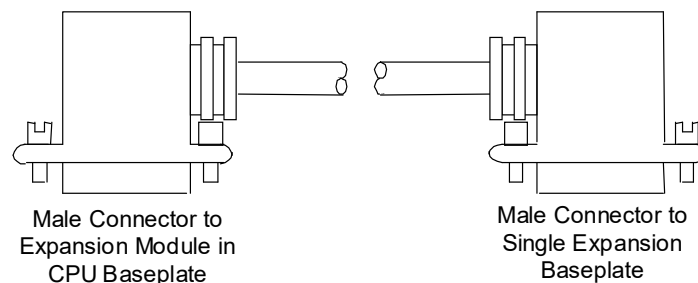
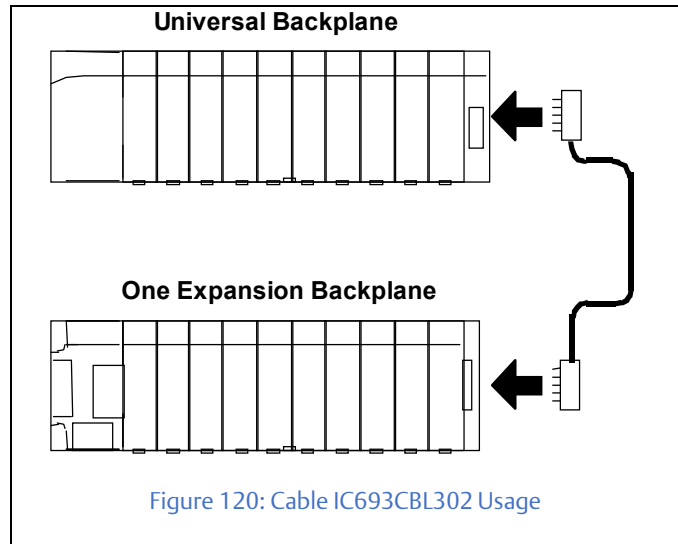

Figure 119: Cable IC693CBL302

This cable does not require a separate termination block. It can only be used in a system with just one expansion backplane (Figure 120).



5.2.2 Cables with Three Connectors: IC693CBL300, 301, 312, 313

Cables IC693CBL300, IC693CBL301, IC693CBL312, and IC693CBL313 (shown in Figure 121) have a male and female connector on one end and a male connector on the other end (“wye” cables).

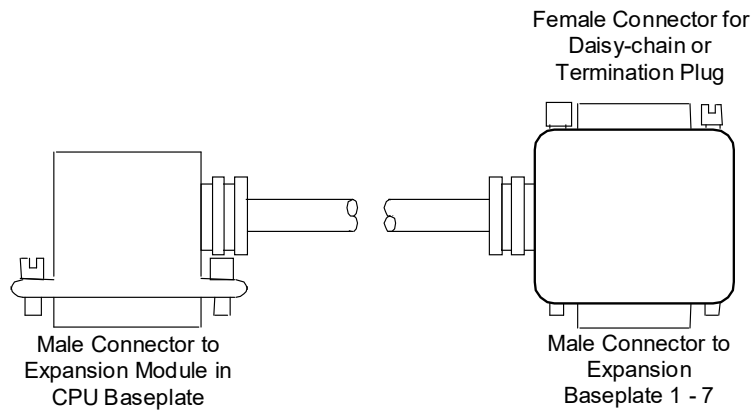

Figure 121: Cables IC693CBL300, IC693CBL301, IC693CBL312, or IC693CBL313

These cables are the same except for their lengths:

- IC693CBL312: 0.15 m (0.5 ft)
- IC693CBL300: 1 m (3 ft)
- IC693CBL301: 2 m (6 ft)
- IC693CBL313: 8 m (25 ft)

Combinations of these cables can be used to daisy-chain up to seven expansion backplanes to the main backplane (Figure 122). Custom cables can also be made. Wiring information is given in this section.

These cables can also be used to provide connection points for custom point-to-point cables (IC693CBL300 is often used for this).

These cables do not have built-in termination. The last cable in the expansion system must be terminated as displayed in bottom right of Figure 122. Terminator Plug IC693ACC307 can be used for this purpose.

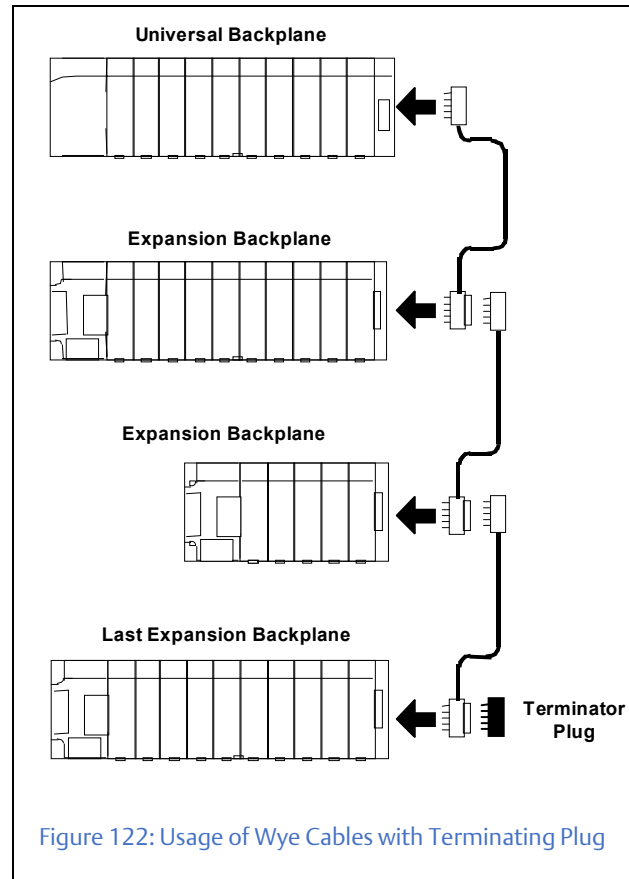

The maximum number of cables that can be included in an I/O expansion system is seven, and the total maximum cable length between the Universal Backplane and the last expansion backplane is 15 m (50 ft). Failure to observe these limits could result in erratic system operation.

5.3 Specifications: IC693CBL300, 301, 302, 312, 313

Cable	Belden 8107 only (no substitutes): Computer cable, overall braid over foil shield, twisted-pair 30 volt/80°C (176°F) 24 AWG (.22mm ²) tinned copper, 7 x 32 stranding Velocity of propagation = 70% Nominal impedance = 100Ω
25-Pin Male Connector	Crimp Plug = Amp 207464-7; Pin = Amp 66506-9 Solder Plug = Amp 5-747912-2
25-Pin Female Connector	Crimp Receptacle = Amp 207463-1; Pin = Amp 66504-9 Solder Receptacle = Amp 5-747913-2