

8 BE brake

8.1 Description

8.1.1 General information

On request, SEW-EURODRIVE motors and gearmotors can be supplied with an integrated mechanical brake. The brake is a DC-operated electromagnetic disk brake that is released electrically and applied using spring force. The brake is applied in case of a power failure. It meets the basic safety requirements.

The brake can also be released mechanically if equipped with manual brake release. Two options are available for manual brake release:

1. With automatic manual brake release (..HR); a hand lever is supplied.
2. With lock-type manual brake release (..HF), a set screw is supplied.

The brake is actuated with a brake control that is either installed in the motor wiring space or in the control cabinet.

A main advantage of brakes from SEW-EURODRIVE is their very short design. The integrated construction of the SEW brakemotor permits particularly compact and sturdy solutions.

8.1.2 Description

The brake is installed on the B-side and integrated in the motor.

It is an electromagnetic, spring-loaded brake powered by energized DC voltage via a rectifier. It uses the two-coil system from SEW-EURODRIVE.

The new BE brake is designed as a modular system and a patent has been applied for. It is generally low-noise.

The principle of the modular brake on a friction disk begins from motor size DR.90. In the smaller DR.71 and DR.80 motors, the brake operates according to the principle of the BM(G) – i.e., "brake integrated" directly on the endshield.

The modular brake allows up to three brake sizes to be fitted to a single motor. The B-side endshield is to be regarded like a mounting flange, which accommodates the BE brake pre-mounted on a friction disk.

Although the integrated brake is mounted on a complete brake endshield, it can be dimensioned to suit specific requirements, just like the modular brake.

8.2 Principles of the BE brake

8.2.1 Basic design

The principal parts of the brake system are the brake coil itself [8] (BS accelerator coil + TS coil section = holding coil), comprising the magnet body [9] with an encapsulated winding and a tap, the moving pressure plate [6], the brake springs [7], the brake disk [1], and the brake endshield [2].

A characteristic feature of SEW brakes is their very short length. The integrated construction of the SEW brakemotor permits particularly compact and sturdy solutions.

8.2.2 Basic function

The pressure plate is forced against the brake disk by the brake springs when the electromagnet is de-energized. The motor is slowed down. The number and type of the brake springs determine the braking torque. When the brake coil is connected to the corresponding DC voltage, the force of the brake springs [4] is overcome by magnetic force [11], thereby bringing the pressure plate into contact with the magnet body. The brake disc moves clear and the rotor can turn.

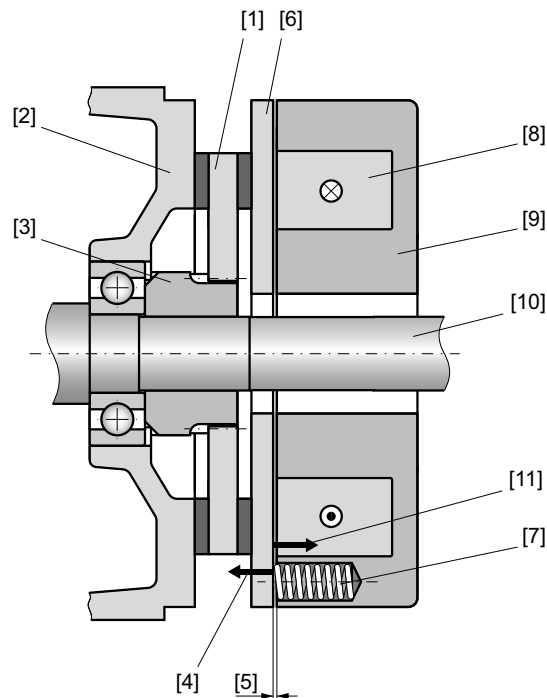

3985157259

- | | |
|---------------------|----------------------------|
| [1] Brake disk | [7] Brake spring |
| [2] Brake endshield | [8] Brake coil |
| [3] Driver | [9] Magnet body |
| [4] Spring force | [10] Motor shaft |
| [5] Working air gap | [11] Electromagnetic force |
| [6] Pressure plate | |

8.2.3 Particularly short response times at switch-on

In contrast to other disk brakes with a DC coil, the SEW brakes operate with a two-coil system. A special brake control ensures that only the accelerator coil is switched on first, followed by the holding coil (entire coil). The powerful impulse magnetization (high acceleration current) of the accelerator coil results in a very short response time, particularly in large brakes, without reaching the saturation limit. The brake disk moves clear very quickly, and the motor starts up with hardly any braking losses.

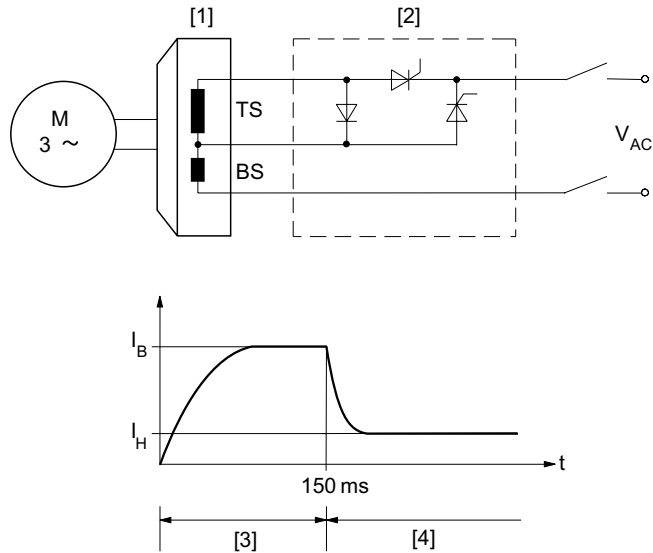

3985172747

- BS Accelerator coil
- TS Coil section
- [1] Brake
- [2] Brake control
- [3] Acceleration
- [4] Holding
- I_B Acceleration current
- I_H Holding current
- BS + TS = holding coil

The particularly short response times of SEW brakes lead to faster motor startup time and minimal startup heating, which reduces energy consumption and brake wear during startup (see following figure). Benefits for the user: very high starting frequency and a long brake service life.

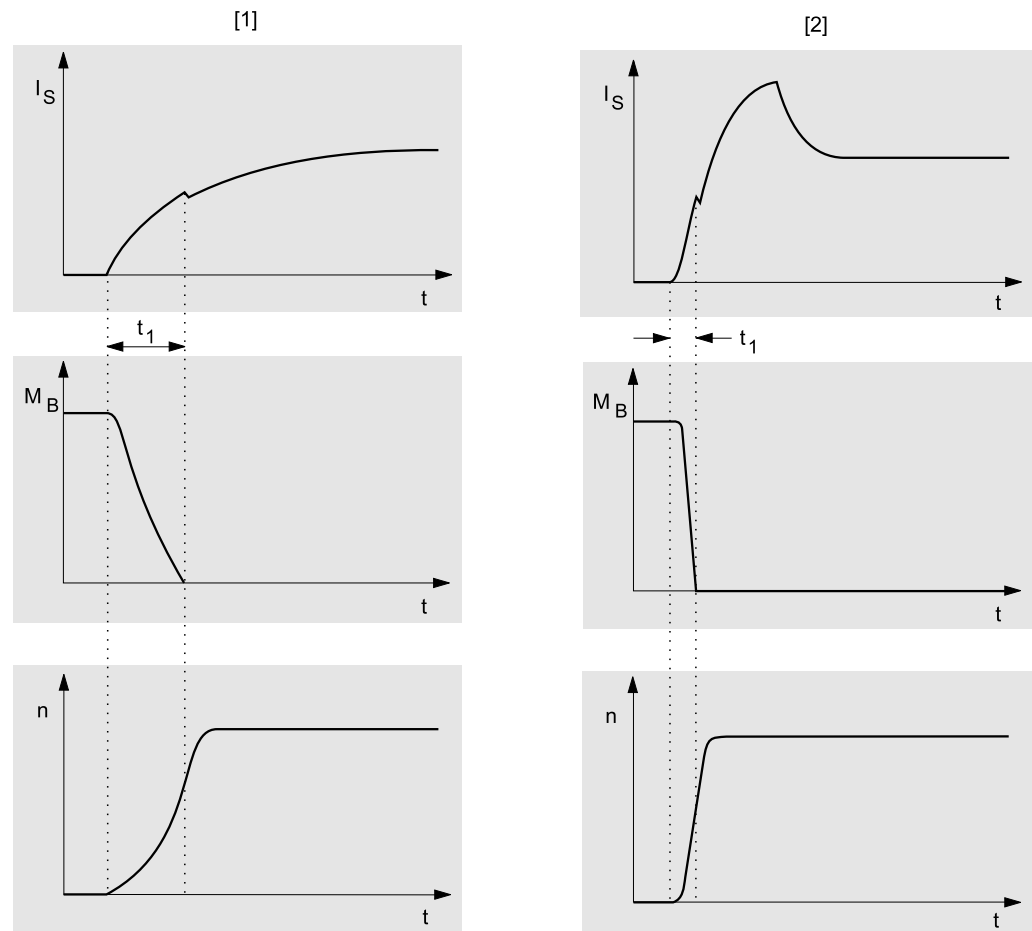

3985174411

- [1] Switch-on procedure for operation with rectifier without switching electronics
 [2] Switch-on procedure for operation with SEW rectifier with switching electronics, e.g., BGE (standard from size BE5)

I_s Coil current
 M_B Braking torque
 n Speed
 t_1 Brake response time

The system switches to the holding coil electronically as soon as the SEW brake has released. The braking magnet is now only magnetized to such an extent (weak holding current) that the pressure plate is held open with a sufficient degree of safety and minimum brake heating.

8.2.4 Particularly short response time at switch-off

A short response time means that de-excitation occurs very rapidly when the coil is switched off and the brake is applied with a very fast response time, particularly with large brakes. User benefits: very short braking distance with high repeat accuracy and a high degree of safety – e.g., for applications involving lifting drives.

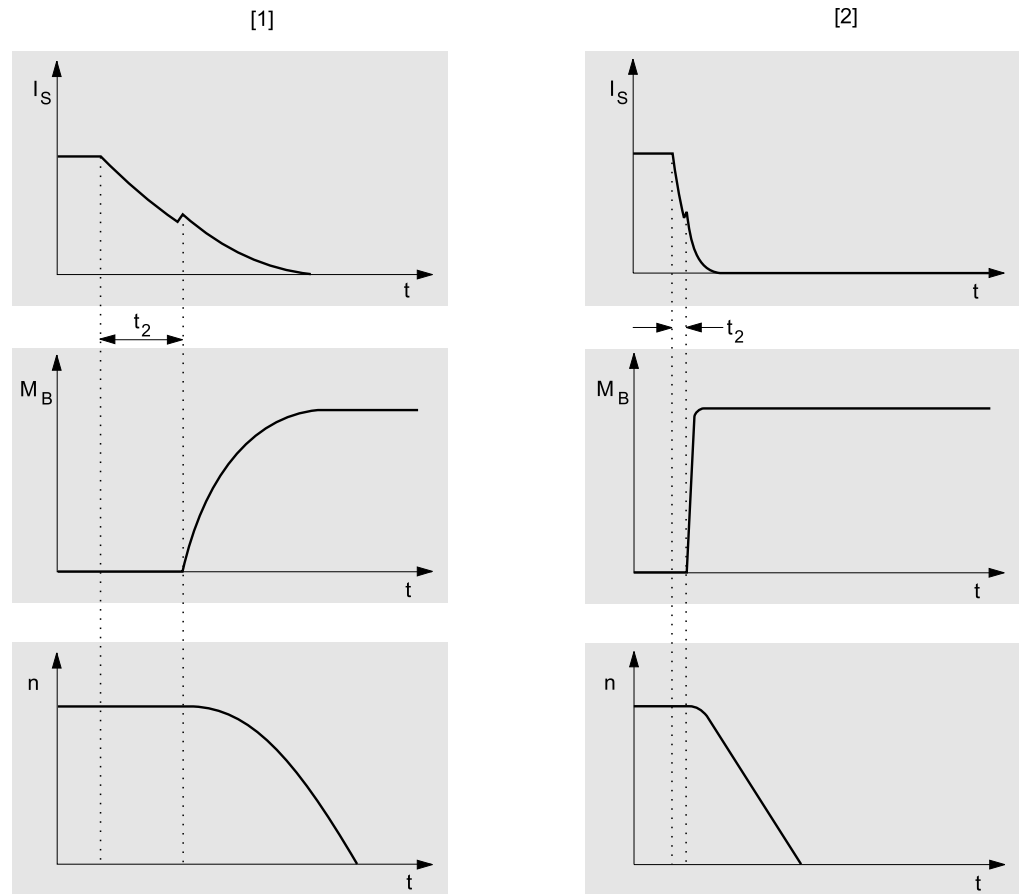

3985177099

[1] Brake response to cut-off in the AC circuit

[2] Brake response to cut-off in the AC and DC circuits

I_s Coil current

M_B Braking torque

n Speed

t_2 Brake application time

The response time for the application of the brake also depends on how rapidly the energy stored in the brake coil is dissipated when the current supply is switched off. A freewheeling diode is used to dissipate the energy for a "cut-off in the AC circuit." The current decays according to an e-function.

The current dissipates much more rapidly via a varistor when the DC and AC circuits are cut-off at the same time as the coil's DC circuit. The response time is significantly shorter. Conventionally, cut-off in the DC and AC circuits is implemented using an additional contact on the braking contactor (suitable for an inductive load).

Under certain conditions, you can also use SR and UR electronic relays for interrupting the DC circuit.

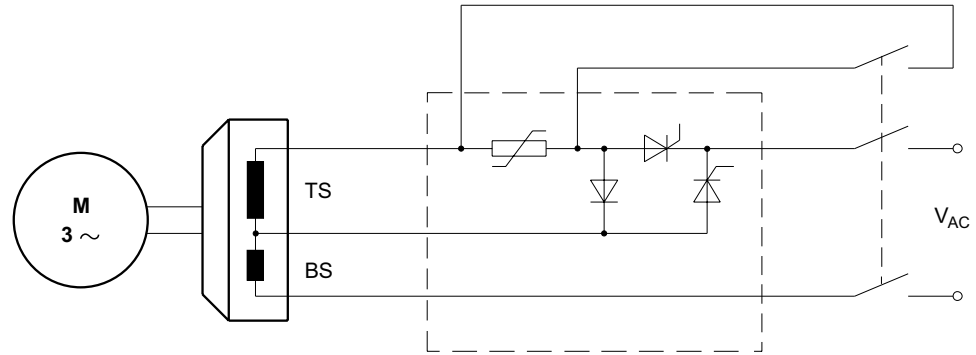

3985178763

8.2.5 Particularly quiet

Many applications in the power range up to approx. 5.5 kW (4-pole) require particularly quiet brakemotors to reduce noise pollution. SEW-EURODRIVE implements special design measures to meet these requirements as standard for all AC brakemotors without affecting the special dynamic features of the brake system.

8.2.6 Particularly safe

Tried and tested design components and brake controls tested in trial applications ensure that the SEW brake has a high degree of operational safety.

8.3 The BE brake in detail

8.3.1 The add-on concept

The BE.. brake is used for AC motors DR.71 – DR.315.

Main features of the brake:

- Various brake sizes can be mounted to each motor size
- Brake coil with tap
- Movable pressure plate
- Plug connector for simple electrical connection, starting at BE20
- The number of brake springs determines the braking torque
- Position of the manual brake release can be defined by the user

Integrated design

Integrated design of the brake for motor types up to size DR.80 means the B-side end-shield of the motor is an integral part of the brake with a friction surface.

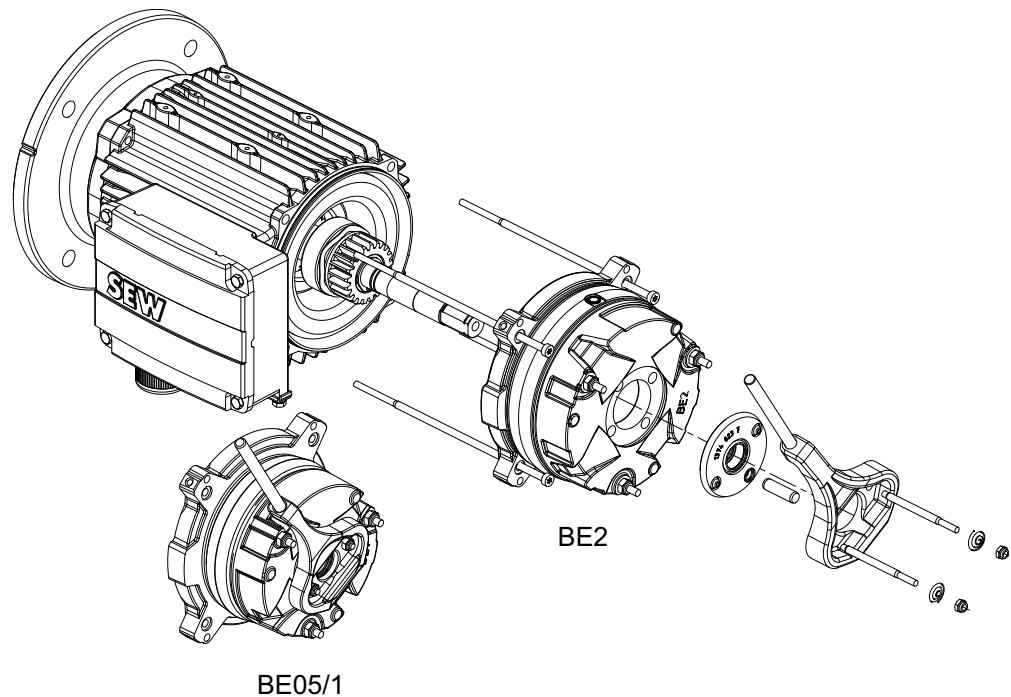

3985185547

Modular design

The modular design of the brake for motor types from DR.90 means the brake has a separate friction disk. The complete bearing of the motor is maintained even when the brake is removed.

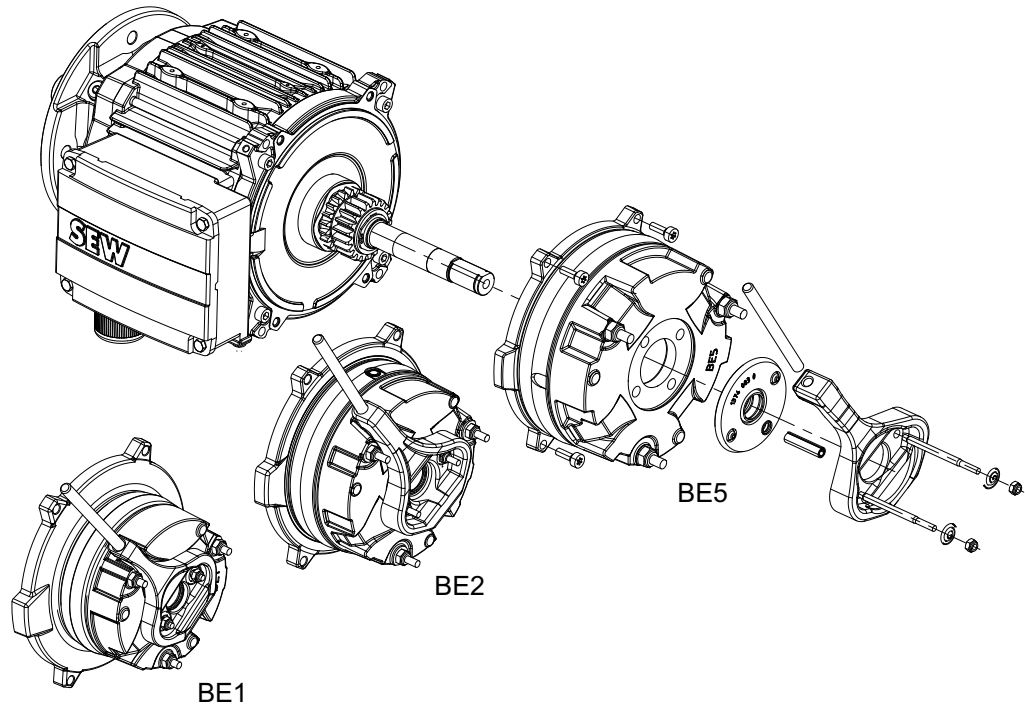

3985188235

8.3.2 Overview of brake/motor assignment

Depending on the demands placed on the brake, different brake mounting sizes are available for mounting to the respective motor.

Brake assignment

The below table shows the possible motor and BE brake assignments and possible braking torques:

Motor	Con-struction	Brake	W _{insp} 10 ⁶ J	Braking torque gradation in Nm												
				1.8	2.5	3.5	5.0	7.0	10	14	20	28	40	55	80	
DR.71	Integra- ted	BE05	120	x	x	x	x									
		BE1	120				x	x	x							
DR.80		BE05	120	x	x	x	x									
		BE1	120				x	x	x							
DR.90		BE2	180				x	x	x	x	x					
		BE5	390							x	x	x	x	x		
		DR.100	BE2	180					x	x	x	x				
BE5			390							x	x	x	x	x		
DR.112 DR. 132		Modu- lar	BE5	390							x	x	x	x	x	
			BE11	640								x	x	x	x	x
DR.160	BE11		640									x	x	x	x	x
	BE20		1000										x	x	x	x
DR.180	BE20		1000										x	x	x	

Motor	Con-struction	Brake	W _{insp} 10 ⁶ J	Braking torque gradation in Nm											
				100	110	150	200	300	400	500	600	800	1000	1200	1600
DR.112 DR.132	Modular	BE11	640		x										
		DR.160	BE11	640		x									
DR.180		BE20	1000		x	x	x								
		BE20	1000		x	x	x								
		BE30	1500	x		x	x	x							
DR.200 DR.225		BE32	1500	x		x	x	x	x	x	x				
		BE60	2500				x	x	x	x	x				
		BE62	2500						x		x	x			
DR.250 DR.280		BE60	2500				x	x	x	x	x				
		BE62	2500						x		x	x	x	x	
	BE120	390						x		x	x	x			
DR.315	BE122	300									x		x		
	BE120	390							x		x	x			
DR.315	BE122	300									x		x	x	

8.4 General information on brake configuration

8.4.1 Project planning procedure

The size of the brakemotor and its electrical connection must be selected carefully to ensure the longest possible service life.

The following aspects described in detail must be taken into account:

1. Selecting the brake/braking torque (→ 355).
2. Determining the brake voltage (→ 360).
3. Selecting the brake control and connection type (→ 360).
4. Dimensioning and routing of the cable (→ 369).
5. Selecting the braking contactor (→ 368).
6. Important design information (→ 374).
7. Motor protection switch (→ 371) if necessary (to protect the brake coil).
8. Diagnostic unit for brake monitoring (→ 522).

8.4.2 Selection criteria

Basic specification	Link/supplement/comment
Motor type	Brake type/brake control system
Braking torque ¹⁾	Brake springs
Brake application time	Connection type of the brake control (important for creation of wiring diagrams)
Braking time Braking distance Deceleration Braking accuracy	The required data can only be observed if the aforementioned parameters meet the requirements
Braking work Brake service life	Adjustment time (important for service)

1) The braking torque is determined from the requirements of the application with regard to the maximum deceleration and the maximum permitted distance or time.

For detailed information on brakemotor size selection and calculation of the braking data, refer to the documentation "Drive Engineering - Practical Implementation – Project Planning for Drives".

8.5 Selecting the brake size and braking torque

The brake suitable for the relevant application is selected by means of the following main criteria:

- Required braking torque
- Required working capacity

8.5.1 Determining the required braking torque

Braking torque

The required braking torque is usually selected according to the required deceleration of the application. Depending on the application, this selection may be influenced by the following:

- Maximum permitted stopping distance
- Maximum permitted deceleration time
- Maximum permitted deceleration

The nominal braking torque values of the BE brakes have been determined and checked in accordance with DIN VDE 0580.

The "Brake assignment" table shows the possible braking torque gradation (→ 353).

As well as the braking distances and times, additional factors have to be considered to determine the actual distance and times until the application comes to a standstill (stopping distances):

- Brake response times

Guide values can be specified (→ 388) for these times on the basis of the brake size and brake control.

- Reaction and signal transit times of the application

These times are application-specific and must be given special consideration during project planning. If in doubt, please consult the manufacturer of your control components

- Braking torque fluctuations

Due to the organic friction ring pads employed, the actual static holding torque or the dynamic braking torque is subject to natural fluctuations and can deviate from the nominal braking torque value depending on the ambient temperature, starting frequency, braking work done, and some other factors.

The variation of the braking distance as a result of braking torque fluctuations has been set empirically at $\pm 12\%$ of the nominal braking distance.

Braking torque in lifting applications

In the case of lifting applications and other uses with an additional static load, such as winding drives, the load torque must also be considered in addition to the selection criteria specified above.

With such applications, the selected braking torque must exceed the highest load torque (static load to be included) by at least a factor of 2 in order to ensure a reliable hold function.

If the brake is used as a pure holding brake (brake application only upon drive standstill), the minimum factor rises to 2.5 since the brake lining does not benefit from natural phases of regeneration resulting from regular dynamic braking.

INFORMATION



It is essential that the specified safety factors are taken into account during project planning, even if some application-specific standards would theoretically permit lower safety factors. Otherwise, SEW-EURODRIVE is unable to guarantee a reliable hold function.

INFORMATION



As a rule, applications with combined horizontal and vertical directions of movement (e.g., inclined conveyors or vehicles on an inclined surface) are to be treated as hoists during project planning. Please contact SEW-EURODRIVE if you are unable to explicitly classify the direction of movement of an application as vertical or horizontal.

8.5.2 Determining the required braking work

Working capacity

The working capacity of the brake is defined by the permitted braking work done W_1 per braking operation and the total permitted braking work W_{insp} until maintenance of the brake.

In general, the braking work per cycle/braking operation W_1 required for the application is initially calculated with the following formula:

$$W_1 = \frac{J_{\text{tot}} \cdot n^2 \cdot M_B}{182.4 \times (M_B \pm M_L)}$$

5463389579

- W_1 = Braking work per braking operation in J
 J_{tot} = Total mass moment of inertia (related to the motor shaft) in kgm^2
 n = Motor speed in rpm
 M_B = Braking torque in Nm
 M_L = Load torque in Nm (observe the +/- character)
 + : for vertical upward movement and horizontal movement
 - : for vertical downward movement

The permitted braking work per cycle/braking operation W_1 is specified in the chapter "Technical data of the BE brake" (→ 375). In the tables and diagrams contained in this chapter, W_1 is distinguished for different brake sizes and applications:

- Use as working brake (conventional line operation)
- Use as holding brake with emergency switching off capacity (usually controlled operation on frequency inverter).

Working brakes

In the case of working brakes, W_1 is specified on the basis of the starting frequency Z (braking operations per hour). No distinction between hoist and powertrain applications is required for working brakes.

W_1 values are specified for various line speeds of 2, 4, 6, and 8-pole drives in 50 Hz or 60 Hz supply systems. These can be found in the diagrams in the chapter "Permissible braking work of the BE brake for working brake operations" (→ 376).

INFORMATION



As of a specific brake size, working brake operations from 2-pole line speeds can no longer be permitted. Please refer to the notes on the diagrams (→ 376) in this regard.

Holding brake with emergency switching off capacity

In the case of holding brakes with emergency switching off capacity, the brake is not used to stop the application during operation, but instead only switches when the drive is at a standstill or in the case of an emergency.

When selecting a brake, a distinction must be made between hoist and powertrain applications.

In the case of holding brakes with emergency braking operations, the same maximum values W_1 initially apply as for working brakes, whereby an hourly starting frequency of $Z = 1$ is assumed. Permissible values can thus be specified for the speeds 750 rpm, 900 rpm, 1200 rpm, 1500 rpm, 1800 rpm, 3000 rpm, and 3600 rpm.

The general rule applies that the diagram of the next highest speed level must be observed for any given speed.

Example:

For an actual speed of 2500 rpm, W_1 must be determined from the diagram for 3000 rpm.

INFORMATION



Calculation of intermediate values through interpolation is not permitted. However, if you should still require more accurate intermediate values, please consult SEW-EURODRIVE.

INFORMATION



The basic speed limit for emergency braking operations is 3600 rpm. As of a specific brake size (BE60 and larger), emergency braking operations from speeds over 1800 rpm can no longer be permitted. If higher speeds are required, please consult SEW-EURODRIVE.

Increased emergency braking work for powertrain applications

For applications with purely horizontal direction of movement, such as in powertrain applications, higher levels of braking work can be permitted for emergency switching off under specific conditions. These conditions are as follows:

- Reduction of the nominal braking torque

The selected nominal braking torque must be at least one stage below the maximum nominal braking torque of the brake size.

Example:

BE20 with $M_{bmax} = 200$ Nm, reduced to 150 Nm for powertrain with increased emergency braking work.

- Extension of braking distance

During the braking operation, the effective dynamic braking torque can be reduced due to the heating of the brake lining. In extreme cases, the effective braking torque can be reduced to 60% of the nominal value. This must be taken into account when calculating the braking distance and braking time (extension by up to 70% in each case).

Example:

BE20 with $M_{BNom} = 150$ Nm, minimal effective torque is $M_{BAct} = 90$ Nm

- Increased wear of brake lining

Due to the heating of the brake lining, the specific wear of the lining can increase significantly. In extreme cases, it can even increase by a factor of 100. This must be taken into account when determining the number of cycles until maintenance (refer to the following section).

INFORMATION



The amount of permitted braking work is dictated by the speed at which the braking operation is triggered. The lower the speed, the higher the permitted braking work.

If, during project planning, you have calculated braking work that exceeds the permitted limit values, you should first attempt to achieve a lower motor speed by changing the gear unit ratio. If you are still unable to ensure a reliable operating situation, you must either use a larger brake or reduce the travel velocity of the application.

Example:

BE20 with $M_{BNom} = 150$ Nm, required braking work $W_1 = 80$ kJ at 2000 rpm. However, according to the table in the chapter "Permitted braking work of the BE brake in case of emergency switching off (→ 385)" only 65 kJ are permitted for BE20 at 2000 rpm. When the speed is reduced to 1600 rpm (by increasing the gear unit ratio by a factor of 1.25), the application becomes possible since 81 kJ are permitted at 1600 rpm.

Determining the number of cycles until maintenance

Particularly in the case of working brakes, the maintenance intervals are usually directly dependent on the braking work done and the resulting wear of the brake linings.

To be able to approximate these intervals, the braking work until maintenance W_{insp} is specified for each brake size. This permitted braking work W_{insp} is specified in the overview table "At a glance" (→ 375).

Based on the previously calculated braking work per cycle W_1 , the permitted number of braking operations until maintenance can be determined:

$$NB = \frac{W_{\text{insp}}}{W_1}$$

5463387659

NB = Number of braking operations until maintenance

W_{insp} = Total braking work until maintenance in J

W_1 = Braking work per braking operation in J

In principle, this calculation method also applies to holding brakes with emergency switching off capacity in hoist and powertrain applications. Here, this method can be used to determine the number of emergency braking operations until maintenance.

If the curves for increased powertrain work (→ 385) are applied for powertrain applications, the calculated number NB must be divided by 100 to take account of the increased wear in this case.

INFORMATION



In the case of holding brakes with emergency switching off capacity, the brake lining wear resulting from emergency braking operations is frequently not the decisive factor in the determination of maintenance intervals. This applies particularly to systems in which actual emergency braking operations are very rare. In such cases, please refer to the maintenance intervals in the drive operating instructions and consult SEW-EURODRIVE if necessary.

8.6 Selecting the brake voltage and brake control

Available brake voltages are specified in the chapter "Operating currents of the BE brakes" (→ 389).

The brake voltage should always be selected on the basis of the available AC supply voltage or motor operating voltage. This means the user is always guaranteed the most cost-effective installation for lower braking currents.

In the case of multi-voltage versions for which the line voltage has not been defined when the motor is purchased, the lower voltage must be selected in each case in order to achieve feasible connection conditions when the brake control is installed in the terminal box.

The standard brake voltages are listed in the following table:

Brake voltage		
Brakes	BE05 – BE20	BE30 – BE122
Voltage range	AC 220 – 242 V AC 380 – 420 V	
Nominal voltage	DC 24 V AC 230 V AC 400 V	- AC 230 V AC 400 V

For the global motors, an extended voltage range applies for the supply voltage of the brakes:

Brake voltage for global motors		
Brakes	BE05 – BE20	BE30 – BE122
Voltage range	AC 220 – 277 V AC 380 – 480 V	

Details on the motor voltages can be found in the chapter "Electrical characteristics" (→ 121).

Low potentials are often unavoidable for reasons of safety. However, they require a considerably greater investment in cables, switchgear, transformers, rectifiers, and overvoltage protection (e.g., for direct 24 V DC supply) than is the case for line voltage supply connections.

With the exception of BG and BMS, the maximum current flowing when the brake is released is 8.5 times the holding current. The voltage at the brake coil must not drop below 90% of the nominal voltage.

INFORMATION



An extended range applies for the permitted supply voltage of the global motor brakes.

If full use is made of this voltage range, the brake cannot be open (released) for long periods without cooling when the motor is stopped or operating at low speeds.

A forced cooling fan must be used if the motor is in use for more than 5 minutes at a speed of under 750 rpm.

8.6.1 Modular brake controls for various applications

The modular concept for brakemotors permits a wide range of variations using electronic and mechanical options. The options include special voltages, mechanical manual brake release, special degrees of protection, plug connections, and special brake control systems.

Various brake controls are available for controlling disk brakes with a DC coil, depending on the requirements and the operating conditions. All brake controls are fitted as standard with varistors to protect against overvoltage.

The brake controls are either installed directly in the motor wiring space or in the control cabinet. For motors of thermal class 180 (H) and explosion-proof motors, the control system must be installed in the control cabinet.

High starting frequency

Brakemotors often demand a high starting frequency and significant external mass moments of inertia.

In addition to the basic thermal suitability of the motor, the brake needs to have a response time t_1 short enough to ensure that it is already released when the motor starts. At the same time, the acceleration required for the mass moment of inertia also has to be taken into account. Without the usual startup phase when the brake is still applied, the temperature and wear balance of the SEW brake permits a high starting frequency.

Brakes from BE5 are designed for a high starting frequency as standard.

The table below shows that, besides BGE (BME) and BSG, the brake control systems BSR, BUR, BMH, BMK, and BMP also have properties for shortening the response time in addition to their other functions.

Brake	High starting frequency	
	Brake control for AC connection	Brake control for 24 V DC connection
BE05	BGE (BSR, BUR) in terminal box or BME (BMH, BMP, BMK) in control cabinet	BSG in terminal box or BMV and BSG in control cabinet
BE1		
BE2		
BE5		
BE11		
BE20		
BE30		
BE32	BGE in terminal box or BME in control cabinet	-
BE60		
BE62		
BE120		
BE122	BMP3.1	

High stopping accuracy

Positioning systems require high stopping accuracy.

Due to their mechanical principle, the degree of wear on the linings, and on-site basic physical conditions, brakemotors are subject to an empirically determined braking distance variation of $\pm 12\%$. The shorter the response times, the smaller the absolute value of the variation.

Cut-off in the DC and AC circuits makes it possible to shorten the brake application time t_{2II} considerably.

Cut-off in the DC and AC circuits is enabled by the following:

- A separate mechanical contact; see Brake control block diagrams (→ 399)
- BMP or BMK brake control with integrated voltage relay for control cabinet installation (→ 363)
- Wear-free electronic relays in the terminal box
 - Current relay (BSR) for motors with fixed speed (→ 365)
 - Voltage relay (BUR) for adjustable-speed motors (→ 366)

Relay retrofitting options suited to the motor and voltage are provided in the chapters "Installation in the control cabinet" and "Installation in the motor wiring space" (→ 363). The electronic relays can switch a maximum braking current of 1 A, thereby limiting the selection to BSR and BUR.

Low and fluctuating ambient temperatures

Brakemotors for low and fluctuating ambient temperatures are exposed to the dangers of condensation and icing. Functional limitations due to corrosion and ice can be prevented by using the BMH brake control with the additional "anti-condensation heating" function.

The "heating" function is activated externally. As soon as the brake has been applied and the heating function switched on during lengthy breaks, both coil sections of the brake control system are supplied with reduced voltage in an inverse-parallel connection by a thyristor operating at a reduced control factor setting. On the one hand, this practically eliminates the induction effect (brake does not release). On the other hand, it results in heating in the coil system, increasing the temperature by approx. 25 K in relation to the ambient temperature.

The heating function must be ended before the brake resumes its normal switching function following a heating period (see brake control BMH, K1 contactor (→ 410)).

BMH is available for motor sizes 71 – 225 and is only mounted in the control cabinet.

Increased ambient temperature or restricted ventilation

In addition to the basic considerations, increased ambient temperature, insufficient supply of cooling air, and/or thermal class 180 (H) are valid reasons for installing the brake control system in the control cabinet.

Only brake controls with electronic switching are used in order to ensure reliable switching at higher winding temperatures in the brake.

The use of BGE, BME, or BSG instead of BG, BMS, or 24 V DC direct connection is prescribed for brake sizes BE05 – BE2 in the special case represented by "electronic brake release when motor at standstill".

Special brakemotor designs for increased thermal loading have to be equipped with brake control systems in the control cabinet.

8.6.2 Installation in control cabinet

The following table lists the technical data of brake controls for installation in the control cabinet and the assignments with regard to motor size and connection technology. The different housings have different colors (= color code) to make them easier to distinguish.

Motor sizes DR.71 – DR.315

Type	Function	Voltage	Holding current I_{Hmax} in A	Type	Part number	Color code
BMS	Without electronic switching	AC 230 – 575 V	1.0	BMS 1.4	8298300	Black
		AC 150 – 500 V	1.5	BMS 1.5	8258023	Black
		AC 42 – 150 V	3.0	BMS 3	8258031	Brown
BME	One-way rectifier with electronic switching	AC 230 – 575 V	1.0	BME 1.4	8298319	Red
		AC 150 – 500 V	1.5	BME 1.5	8257221	Red
		AC 42 – 150 V	3.0	BME 3	825723X	Blue
BMH	One-way rectifier with electronic switching and heating function	AC 230 – 575 V	1.0	BMH 1.4	8298343	Green
		AC 150 – 500 V	1.5	BMH 1.5	825818X	Green
		AC 42 – 150 V	3.0	BMH 3	8258198	Yellow
BMP	One-way rectifier with electronic switching, integrated voltage relay for cut-off in the DC circuit	AC 230 – 575 V	1.0	BMP 1.4	8298327	White
		AC 150 – 500 V	1.5	BMP 1.5	8256853	White
		AC 42 – 150 V	3.0	BMP 3	8265666	Light blue
BMP 3.1	One-way rectifier with electronic switching, integrated voltage relay for cut-off in the DC circuit.	AC 230 – 575 V	2.8	BMP 3.1	8295077	-
BMK	One-way rectifier with electronic switching, 24 V DC control input, and cut-off in the DC circuit	AC 230 – 575 V	1.0	BMK 1.4	8298335	Water blue
		AC 150 – 500 V	1.5	BMK 1.5	8264635	Water blue
		AC 42 – 150 V	3.0	BMK 3	8265674	Bright red
BMV	Brake control unit with electronic switching, 24 V DC control input, and fast cut-off	DC 24 V	5.0	BMV 5	13000063	White

Type	Design	Standard terminal box	IS integrated plug connector	IV industrial plug connector ¹⁾ (AC., AS., AM., AB., AK., AD..)
BMS	BMS 1.4 BMS 1.5 BMS 3	71 – 100 / BE2	71 – 100 / BE2	71 – 100 / BE2
BME	BME 1.4 BME 1.5 BME 3	71 – 225 / BE32 250, 280 / BE60/62	71 – 132 / BE11	71 – 225 / BE32
BMP	BMP 1.4 BMP 1.5 BMP 3 BMP 3.1	71 – 225 / BE32 250, 280 / BE60/62	71 – 132 / BE11	71 – 225 / BE32
BMK	BMK 1.4 BMK 1.5 BMK 3	71 – 225 / BE32	71 – 132 / BE11	71 – 225 / BE32
BMH	BMH 1.4 BMH 1.5 BMH 3	71 – 225 / BE32	71 – 132 / BE11	71 – 225 / BE32
BMV	BMV 5	71 – 180 / BE20	71 – 132 / BE11	71 – 180 / BE20

1) Observe the permitted amperage of the relevant plug connector

8.6.3 Installation in motor wiring space

The following table lists the technical data of brake control systems for installation in the motor wiring space and the assignments with regard to motor size and connection technology. The different housings have different colors (= color code) to make them easier to distinguish.

Motor sizes DR.71 – DR.315

Type	Function	Voltage	Holding current I_{Hmax} in A	Type	Part number	Color code
BG ¹⁾	Without electronic switching	AC 230 – 575 V	1.0	BG 1.4	8278814	Black
		AC 150 – 500 V	1.5	BG 1.5	8253846	Black
		AC 24 – 150 V	3.0	BG 3	8253862	Brown
BGE	One-way rectifier with electronic switching	AC 230 – 575 V	1.0	BGE 1.4	8278822	Red
		AC 150 – 500 V	1.5	BGE 1.5	8253854	Red
		AC 42 – 150 V	3.0	BGE 3	8253870	Blue
BS ¹⁾	Terminal block with varistor protection circuit	DC 24 V	5.0	BS24	8267634	Water blue
BSG	Brake control unit with electronic switching	DC 24 V	5.0	BSG	8254591	White
BMP 3.1	One-way rectifier with electronic switching, integrated voltage relay for cut-off in the DC circuit.	AC 230 – 575 V	2.8	BMP 3.1	8295077	-

1) BE05 – BE2 only

Type	Design	Standard terminal box	IS integrated plug connector	IV industrial plug connector ¹⁾ (AC., AS., AM., AB., AK., AD.)
BG	BG1.4 BG1.5 BG3	71 – 100 / BE2	71 – 100 / BE2	71 – 100 / BE2
BGE	BGE1.4 BGE1.5 BGE3	71 – 280 / BE62	71 – 132 / BE11	71 – 225 / BE32
BS	BS24	71 – 100 / BE2	71 – 100 / BE2	71 – 100 / BE2
BSG	BSG	71 – 180 / BE20	71 – 132 / BE11	71 – 180 / BE20

1) Observe the permitted amperage of the relevant plug connector

8.6.4 Installation in the wiring space of the motor with additional switching relay BSR, BUR

BSR brake control

The BSR brake control combines the BGE control unit with an electrical SR current relay. In combination with a current relay, the BGE is supplied with voltage directly from the motor terminal board, meaning that no special incoming cable is required.

When the motor is disconnected, the motor current is interrupted practically instantaneously and is used for cut-off in the DC circuit of the brake coil via the SR current relay. This feature results in particularly fast brake application despite the remanence voltage at the motor terminal board and in the brake control system.

The brake voltage is defined automatically on the basis of the motor phase voltage without further customer data (e.g. motor 230 V/400 V, brake 230 V). As an option, the brake coil can also be configured for the line-to-line voltage (e.g. motor 400 V, brake 400 V).

The current relay and brake rectifier are allocated depending on the specified motor and brake voltages when ordering.

The following table shows the allocation of SR current relays to the nominal motor current I_N in Δ connection and the maximum holding current of the brake I_{Hmax} .

$$I_{Hmax} = I_H \times 1.3 A_{Ac}$$

Motor assignment	Current relay	Nominal motor current I_N in A in Δ connection	Max. holding current of the brake I_{Hmax} in A
DR.71 – 132	SR10	0.075 – 0.6	1
	SR11	0.6 – 10	1
	SR15	10 – 50	1
DR.160 – 225	SR15	10 – 30	1
	SR19	30 – 90	1

Type	Function	Voltage	Holding current I_{Hmax} in A	Type	Part number	Color code
BSR	One-way rectifier with current relay for cut-off in the DC circuit	AC 150 – 500 V	1.0	BGE 1.5 + SR 10	8253854 0826760X	Red -
			1.0	BGE 1.5 + SR 11	8253854 8267618	Red -
			1.0	BGE 1.5 + SR 15	8253854 8267626	Red -
			1.0	BGE 1.5 + SR 19	8253854 8262462	Red -
		AC 42 – 150 V	1.0	BGE 3 + SR10	8253870 0826760X	Blue -
			1.0	BGE 3 + SR11	8253870 8267618	Blue -
			1.0	BGE 3 + SR15	8253870 8267626	Blue -
			1.0	BGE 3 + SR19	8253870 8262462	Blue -

Type	Design	Standard terminal box	IS integrated plug connector	IV industrial plug connector ¹⁾ (AC.., AS.., AM.., AB.., AK.., AD..)
BSR	BGE1.5 + SR10 BGE1.5 + SR11 BGE1.5 + SR15 BGE1.5 + SR19 BGE3 + SR10 BGE3 + SR11 BGE3 + SR15 BGE3 + SR19	71 – 225 / BE62	71 – 132 / BE11	71 – 225 / BE32

1) Observe the permitted amperage of the relevant plug connector

BUR brake control

The BUR brake control system combines the BGE control unit with an electronic UR voltage relay. In this case, the BGE control unit has a separate voltage supply because there is no constant voltage at the motor terminal board (pole-changing motors, motors operated on a frequency inverter) and because the remanence voltage of the motor (single-speed motor) would cause a delay in the brake application time.

With cut-off in the AC circuit, the UR voltage relay triggers cut-off in the DC circuit of the brake coil almost instantaneously and the brake is applied especially quickly.

The brake voltage is defined automatically on the basis of the motor phase voltage without further customer data. Optionally, other brake voltages can be defined in accordance with the following table.

Brakes	BUR (BGE + UR..) for brake control (AC V)											
	79 -123	124 -138	139 -193	194 -217	218 -243	244 -273	274 -306	307 -343	344 -379	380 -431	432 -484	485 -542
BE05												
BE1												
BE2												
BE5												
BE11												
BE20												
BE30												
BE32												

UR15
 UR11
 Not possible

Type	Function	Voltage	Holding current I_{Hmax} in A	Type	Part number	Color code
BUR	Half-wave rectifier and voltage relay for cut-off in the DC circuit	AC 150 – 500 V	1.0	BGE 1.5 + UR 15	8253854 8267596	red -
		AC 42 – 150 V	1.0	BGE 3 + UR 11	8253870 8267588	blue -

Type	Design	Standard connection box	IS integrated plug connector	Industrial plug connector IV ¹⁾ (AC.., AS.., AM.., AB.., AK.., AD..)
BUR	BGE1.5 + UR15 BGE3 + UR11	71 – 225 / BE32	71 – 132 / BE11	71 – 225 / BE32

1) Note the permitted current strength of the relevant plug connector

8.6.5 Brake voltage supply via motor terminal board

The supply voltage for brakes with an AC connection is either supplied separately or taken from the supply system of the motor in the wiring space. Only motors with a fixed speed can be supplied by the motor supply voltage. The supply voltage for the brake must be supplied separately with multi-speed motors and for operation with a frequency inverter.

Furthermore, bear in mind that the brake response is delayed by the residual voltage of the motor if the brake is powered with motor supply voltage. The brake application time t_{2l} for cut-off in the AC circuit, (→  388) specified in the brake's technical data, applies to a separate supply only.

Direct voltage supply to the brake from the motor terminal board or from the KCC terminal strip is only possible with constant speed motors.

In hoists and hoist-like applications, this type of voltage supply is only permitted with an additional current relay (BSR control), which ensures the application of the brake also when the hoist is moving downward.

INFORMATION



In variable-speed motors, the brake voltage must not be picked up at the motor terminal board because the voltage there is not constant.

8.6.6 Parallel operation of several brakes with one controller

Brakes must be switched at the same time in multi-motor operation. The brakes must also be applied together when a fault occurs in one brake.

Simultaneous switching can be achieved by connecting any particular group of brakes in parallel to one brake control.

When several brakes are connected in parallel to the same brake rectifier, the total of all the operating currents must not exceed the rated current of the brake control.

INFORMATION



If a fault occurs in one brake, all brakes must be cut-off in the AC circuit.

8.7 Selection of voltage supply line and protection devices

8.7.1 Selecting the braking contactor

In view of the high current loading and the DC voltage to be switched at inductive load, the switchgear for the brake voltage and cut-off in the DC circuit either has to be a special DC contactor or an adapted AC contactor with contacts in utilization category AC 3 to EN 60947-4-1.

It is simple to select the braking contactor for line operation:

- For the standard voltages AC 230 V or AC 400 V, a power contactor with a rated power of 2.2 kW or 4 kW for AC-3 operation is selected.
- The contactor is configured for DC-3 operation with DC 24 V.

When applications require cut-off in the DC and AC circuits for the brake, it is a good idea to install SEW switchgear to perform this task.

Control cabinet installation

The brake rectifiers BMP (→ 407), BMV (→ 411) and BMK (→ 411) which perform (→ 363) the cut-off in the DC circuit internally, have been specially designed for this purpose.

Terminal box installation

The current and voltage relays SR1x (→ 365) and UR1x (→ 366), which are mounted directly on the motor, perform the same task.

Advantages compared to switch contacts:

- Special contactors with four AC-3 contacts are not required.
- The contact for cut-off in the DC circuit is subject to high loads and, therefore, a high level of wear. In contrast, the electronic switches operate without any wear at all.
- Customers do not have to perform any additional wiring. The current and voltage relays are wired at the factory. Only the power supply and brake coil have to be connected for the BMP and BMK rectifiers.
- Two additional conductors between the motor and control cabinet are no longer required.
- No additional interference emission from contact bounce when the brake is cut-off in the DC circuit.

Semi-conductor relay

Semi-conductor relays with RC protection circuits are not suitable for switching brake rectifiers with the exception of BG and BMS.

8.7.2 Dimensioning and routing of the cable

Select the cross section of the brake cable according to the currents in your application. Note the inrush current of the brake when selecting the cross section. When taking the voltage drop into account due to the inrush current, the value must not drop below 90 % of the rated voltage. The tables "BE brake – operating currents" (→ 389) provide information on the possible supply voltages and the resulting operating currents.

Refer to the tables below as a quick source of information for selecting the size of the cable cross sections with regard to the acceleration currents for cable lengths ≤ 50 m.

BE05 – BE122

Brakes	Minimum cable cross section of the brake cables in mm ² (AWG) for cable lengths ≤ 50 meters and brake voltage (AC V)					
	24	60 DC 24 V	120	184 - 208	230	254 - 575
BE05	10 (8)					
BE1						
BE2		2.5 (12)			1.5 (16)	
BE5	1)	4 (10)				
BE11		10 (8)	2.5 (12)			
BE20						
BE30 / 32						
BE120/122						

1) Not available

BE60 / 62, BR03

Brakes	Minimum cable cross section of the brake cables in mm ² (AWG) for cable lengths ≤ 50 meters and brake voltage (AC V)							
	42	48	56 DC 24 V	110	125-153	175-200	208-230	254-500
BR03				1.5 (16)				
BE60 / 62				1)			2.5 (14)	

1) Not available

Values in brackets = AWG (American Wire Gauge)

Wire cross sections of max. 2.5 mm² can be connected to the terminals of the brake control systems. Intermediate terminals must be used if the cross sections are larger.

Brake cables must always be routed separately from other power cables with phased currents unless they are shielded.

Provide for a suitable equipotential bonding between drive and control cabinet.

In particular, power cables with phased currents include:

- Output cables from frequency inverters and servo inverters, soft-start units and brake units
- Supply cables to braking resistors.

8.7.3 Varistor overvoltage protection with direct DC voltage supply

The brakes of sizes BE05 to BE2 can be operated with direct DC voltage without brake control, see technical data in chapter "BE brake – operating currents" (→ 389).

In this case, a suitable overvoltage protection in the form of a varistor must be installed by the customer to protect the switch contacts and the brake coil. This must be connected in parallel to the coil according to the diagram displayed below.

The following figure shows a varistor for protecting the brake coil.

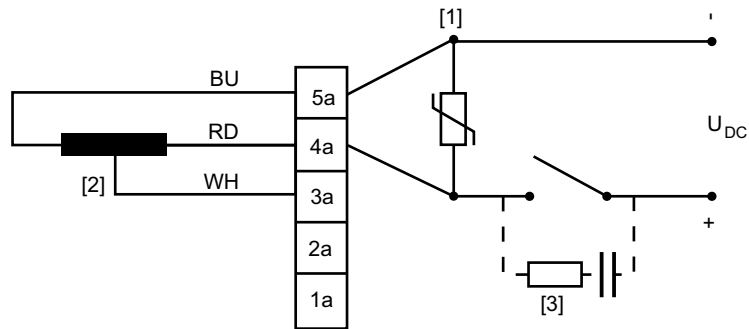

5463392779

[1]	Varistor	WH	white
[2]	Brake coil	RD	red
[3]	RC element	BU	blue

Example of a suitable varistor: SIOV-S10 K300, manufacturer EPCOS (varistor for 300 V).

INFORMATION



Please note:

The use of a freewheeling diode as overvoltage protection instead of a varistor is not permitted, as this can significantly extend brake application times.

If there are still problems with EMC interference in the voltage supply line despite the varistor overvoltage protection, then a suitable RC element can also be connected in parallel to the switch contact.

Only use switch contacts which are suitable for switching inductive loads to DC voltages! See chapter "Selection of braking contactor" (→ 368).

Special case: Brakes with DC 24 V supply

SEW-EURODRIVE always recommends the use of a BMV brake control for brakes with DC 24 V supply.

The BMV brake control has a wear-free, electronic switch which prevents, in particular, contact-breaking sparks when switching off the brake which could lead to EMC interference. BMV controls also have a powerful overvoltage protection for the switch contacts and the brake coil.

If the brake is not connected via a BMV brake control, then a varistor overvoltage protection is necessary as shown in the example above, although in the special case of a DC 24 V power supply, a varistor for a lower voltage should be used, e.g. SIOV-S10 K35, manufactured by EPCOS (varistor for 35 V).

8.7.4 Motor overload circuit breaker

Motor protection switches such as ABB type M25-TM are suitable as protection against short circuits for the brake rectifier and as thermal protection for the brake coil.

Select or set the motor protection switch to $1.1 \times I_H$ (I_H = brake holding current, r.m.s. value). For more information regarding holding current, refer to the "Installation in motor wiring space" (→  363) section.

Motor protection switches are suitable for all brake rectifiers in the control cabinet (important: except for the BMH heating function) and in the terminal box with separate voltage supply.

8

BE brake

Selection of voltage supply line and protection devices

Advantage: Motor protection switches prevent the brake coil from being destroyed when a fault occurs in the brake rectifier or the brake coil is connected incorrectly.

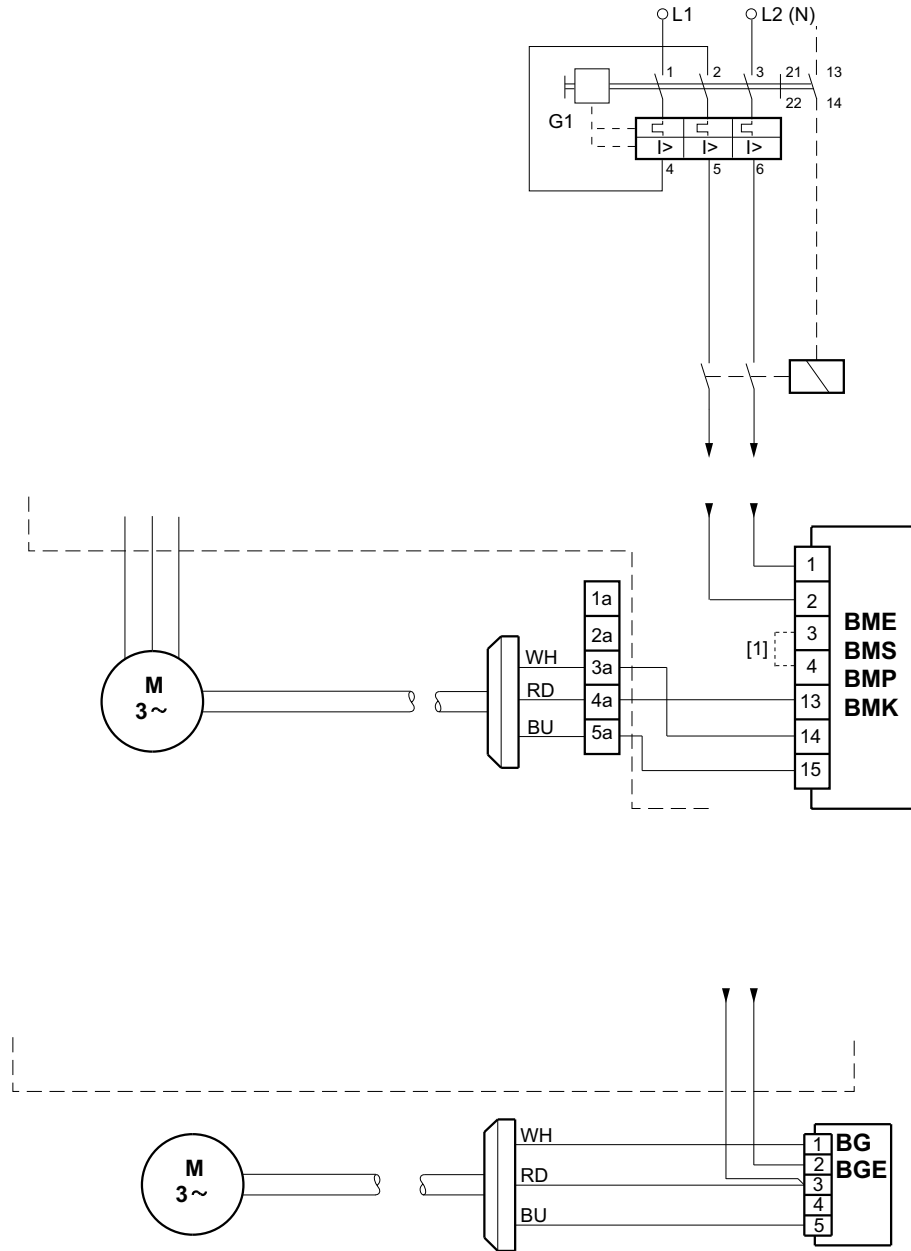

3985796235

[1] Customers must connect terminals 3 and 4 according to the relevant wiring diagram.

Key:

WH	white
RD	red
BU	blue

8.8 Brakes for global motors

The global motor brakes have an extended range of permitted supply voltage.

If full use is made of this voltage range, the brake cannot be open for long periods (released) without cooling when the motor is stopped or operating at low speeds.

A forced cooling fan must be used if the motor is in use for more than 5 minutes at a speed of under 750 rpm.

8.9 Important design information

8.9.1 EMC (Electromagnetic compatibility)

SEW AC brakemotors comply with the relevant EMC generic standards when operated in accordance with their designated use in continuous duty connected to mains power.

Additional instructions in the frequency inverter documentation must also be taken into account for operation with frequency inverters.

The instructions on laying cables (→  369) must always be adhered to.

8.9.2 Connection type

The electrical design team and, in particular the installation and startup personnel, must be given detailed information on the connection type and the intended brake function.

Maintaining certain brake application times may be relevant to safety. The decision to implement cut-off in the AC circuit or cut-off in the DC and AC circuits must be passed on clearly and unambiguously to the people undertaking the work. The brake application times t_{2I} specified in the data summary (→  388) for cut-off in the AC circuit only apply if there is a separate voltage supply. The times are longer if the brake is connected to the terminal board of the motor.

BG and BGE are always supplied wired up for cut-off in the AC circuit in the terminal box. The blue wire from the brake coil must be moved from terminal 5 of the rectifier to terminal 4 for cut-off in the AC and DC circuits. An additional contactor (or SR / UR) must also be connected between terminals 4 and 5.

8.9.3 Determining maintenance intervals

The time to maintenance is determined on the basis of the expected brake wear. This value is important for setting up the maintenance schedule for the machine to be used by the customer's service personnel (machine documentation).

8.9.4 Important measuring principles

The following points must be observed during service measurements on the brakes:

The values for DC voltage specified in the data sheets only apply if brakes are supplied with DC voltage from an external source without an SEW brake control.

Due to the fact that the freewheeling arm only extends over the coil section, the DC voltage that can be measured during operation with the SEW-EURODRIVE brake control is 10% – 20% lower than the normal one-way rectification when the freewheeling arm extends over the entire coil.

8.10 BE brake technical data

This section contains all the necessary technical data for project planning and operation.

- Braking work
 - until service (see following table)
 - for working brake actions (→ 376)
 - for emergency stop braking operations (→ 385)
- Cycle times (→ 388)
- Braking torque (see following table)
- Operating currents (→ 389)
- Resistance brake coils (→ 394)
- Brake control block diagrams (→ 399)
- Information about safety-rated brakes (→ 415)

8.10.1 At a glance: braking work, working air gap, braking torque, brake spring

The braking torque is determined depending on the nominal motor torque and corresponds approximately to double the nominal motor torque unless specified otherwise in the order.

Brakes	Braking work until maintenance	Working air gap		Brake disk	Part number damping plate	Braking torque settings					
		mm		mm		Brake torque	Type and number of			Purchase order number for Brake springs	
		min. ¹⁾	max.	min.			Nm (lb-in)	Normal	blue	white	Normal
BE05	120	0.25	0.6	9.0	13740563	5.0 (44) 3.5 (31) 2.5 (22) 1.8 (16)	3 – – –	4 6 3 –	– – – –	0135017X	13741373
BE1	120	0.25	0.6	9.0	13740563	10 (88.5) 7.0 (62) 5.0 (44)	63 4 –	– 2 –	– – –	0135017X	13741373
BE2	180	0.25	0.6	9.0	13740199	20 (177) 14 (124) 10 (88.5) 7.0 (62) 5.0 (44)	6 2 2 – –	– 4 2 4 3	– – – – –	13740245	13740520
BE5	390	0.25	0.9	9.0	13740695	55 (487) 40 (354) 28 (248)	6 2 2	– 4 2	– – –	13740709	13740717
						20 (177) 14 (124)	– –	– –	6 4		13747738
BE11	640	0.3	1.2	10.0	13741713	110 (974) 80 (708) 55 (487) 40 (354)	6 2 2 –	– 4 2 4	– – – –	13741837	13741845
					13741713 + 13746995	28 (248) 20 (177)	– –	3 –	– 4		13741837
					–	200 (1770) 150 (1328) 110 (974) 80 (708) 55 (487)	6 4 3 3 –	– 2 3 – 4	– – – – –	13743228	13742485
13746758	40 (354)	–	3	–							

19290411/EN – 10/2014

Brakes	Braking work until maintenance	Working air gap		Brake disk	Part number damping plate	Braking torque settings					
		mm				Nm (lb-in)	Type and number of			Purchase order number for Brake springs	
		10 ⁶ J	min. ¹⁾	max.			min.	Normal	blue	white	Normal
BE30	1500	0.3	1.2	10.0	–	300 (2655) 200 (1770) 150 (1328) 100 (885) 75 (667)	8 4 4 – –	– 4 – 8 6	– – – – –	01874551	13744356
BE32	1500	0.4	1.2	10.0	–	600 (5310) 500 (4425) 400 (3540) 300 (2655) 200 (1770) 150 (1328)	8 6 4 4 – –	– 2 4 – 8 6	– – – – – –	01874551	13744356
					13746731	100 (885)	–	4	–		
BE60	2500	0.3	1.2	1.2	–	600 (5310) 500 (4425) 400 (3540) 300 (2655) 200 (1770)	8 6 4 4 –	– 2 4 – 8	– – – – –	01868381	13745204
BE62	2500	0.4	1.2	1.2	–	1200 (10621) 1000 (8851) 800 (7081) 600 (5310) 400 (3540)	8 6 4 4 –	– 2 4 – 8	– – – – –	01868381	13745204
BE120	390	0.6	1.2	12.0	–	1000 (8851) 800 (7081) 600 (5310) 400 (3540)	8 6 4 4	– 2 4 –	– – – –	13608770	13608312
BE122	300	0.8	1.2	12.0	–	2000 (17701) 1600 (14161) 1200 (10621) 800 (7081)	8 6 4 4	– 2 4 –	– – – –	13608770	13608312

1) When checking the working air gap, note: Parallelism tolerances on the brake disk may give rise to deviations of ±0.15 mm after a test run.

The following table shows the brake spring layout:

BE05 – BE20:					
6 springs	3 + 3 springs	4 + 2 springs	2 + 2 springs	4 springs	3 springs
BE30 – BE122:					
8 springs	6 + 2 springs	4 + 4 springs	6 springs	4 springs	

8.10.2 Permissible braking work of the BE brake for working brake actions

If you are using a brake motor, you have to check whether the brake is approved for use with the required starting frequency "Z". The following diagrams show the permitted braking work W_1 per braking operation for different brakes and rated speeds. The values are given with reference to the required starting frequency "Z" in cycles/hour (1/h).

BE05, BE1, BE2, BE5, BE11, BE20, BE30, BE32

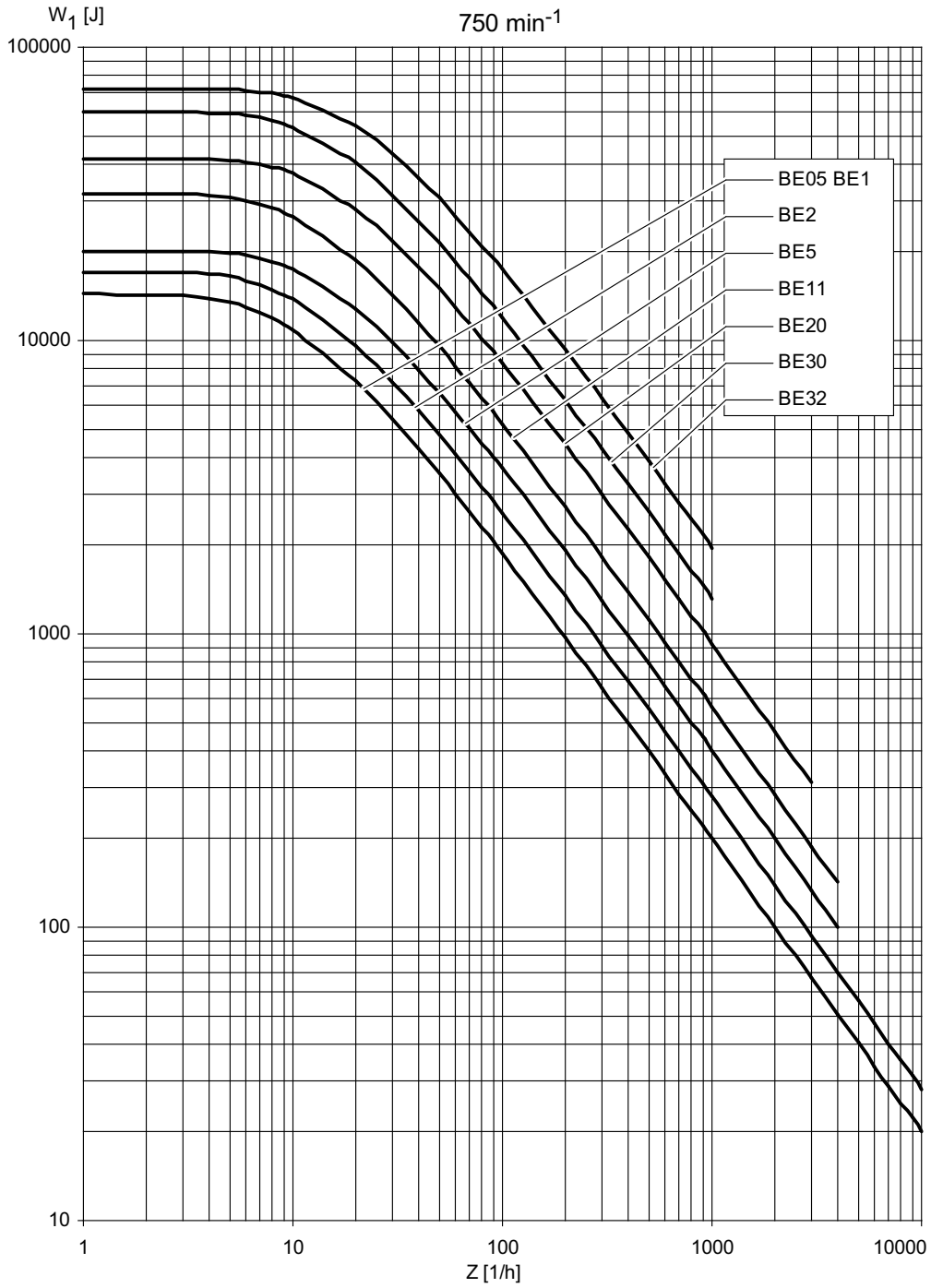

9007203295423883

19290411/EN – 10/2014

BE05, BE1, BE2, BE5, BE11, BE20, BE30, BE32

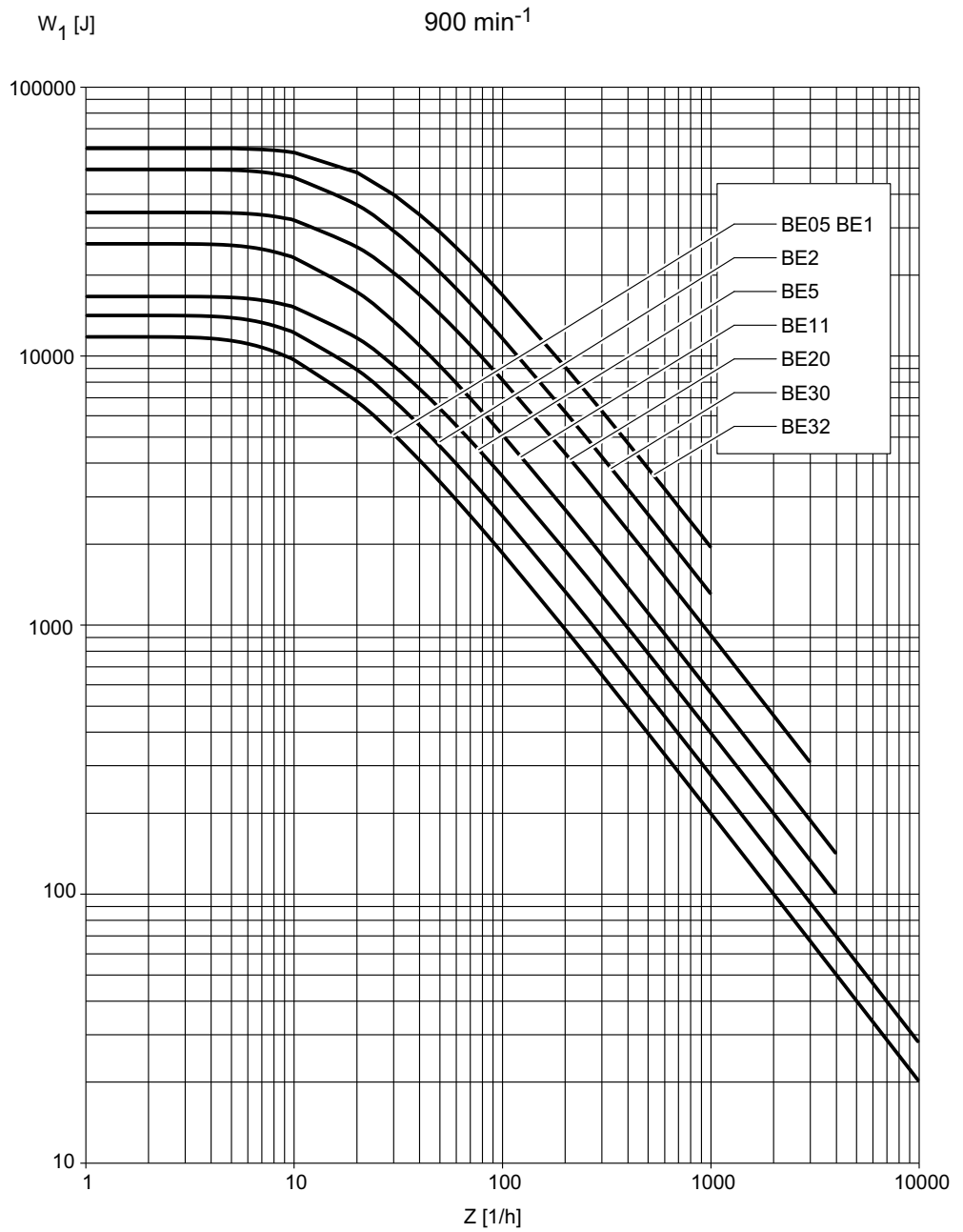

9007204858323083

BE05, BE1, BE2, BE5, BE11, BE20, BE30, BE32, BE60, BE62

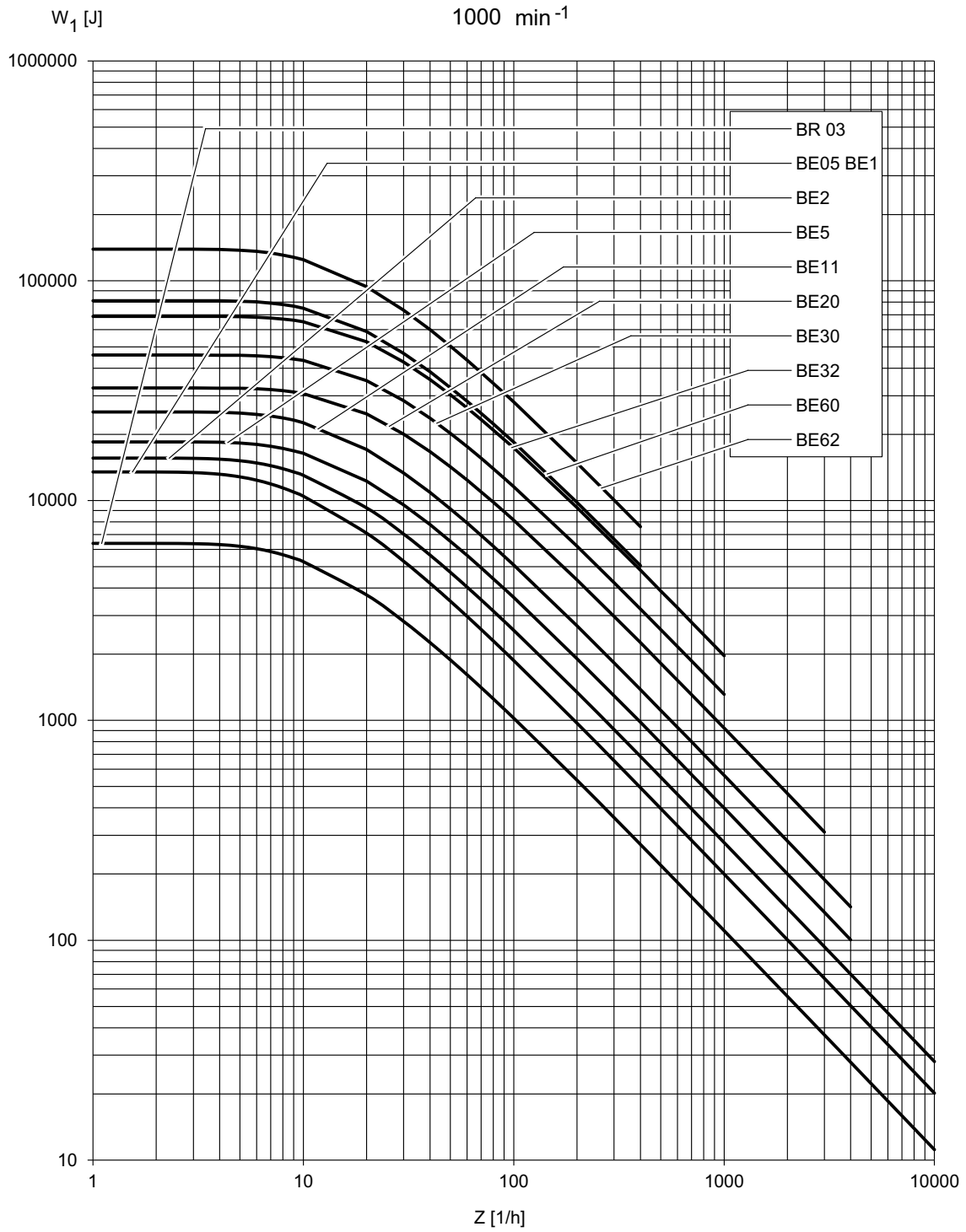

8

9007203295421195

19290411/EN – 10/2014

BE05, BE1, BE2, BE5, BE11, BE20, BE30, BE32, BE60, BE62

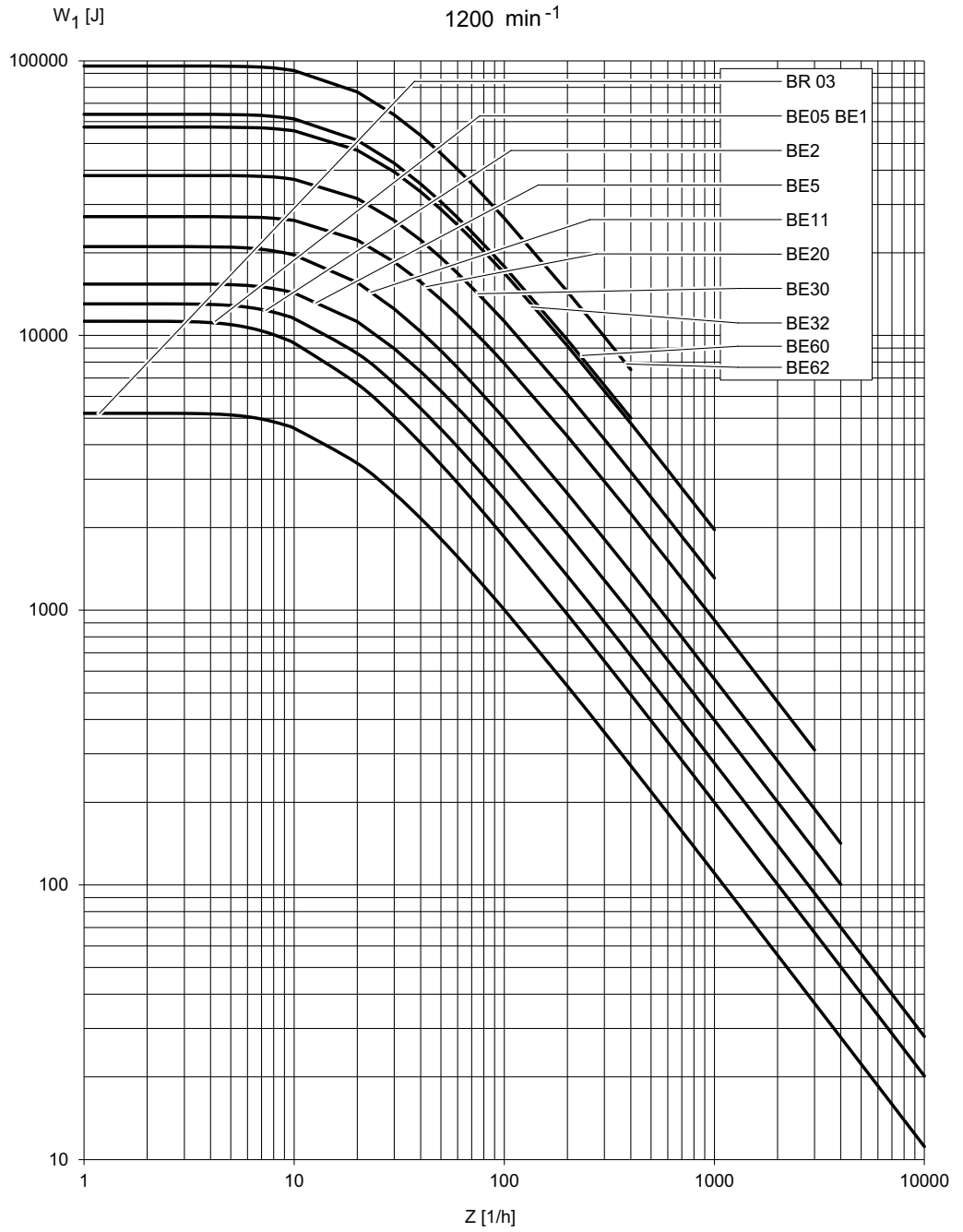

9007204859132171

BE05, BE1, BE2, BE5, BE11, BE20, BE30, BE32, BE60, BE62, BE120, BE122

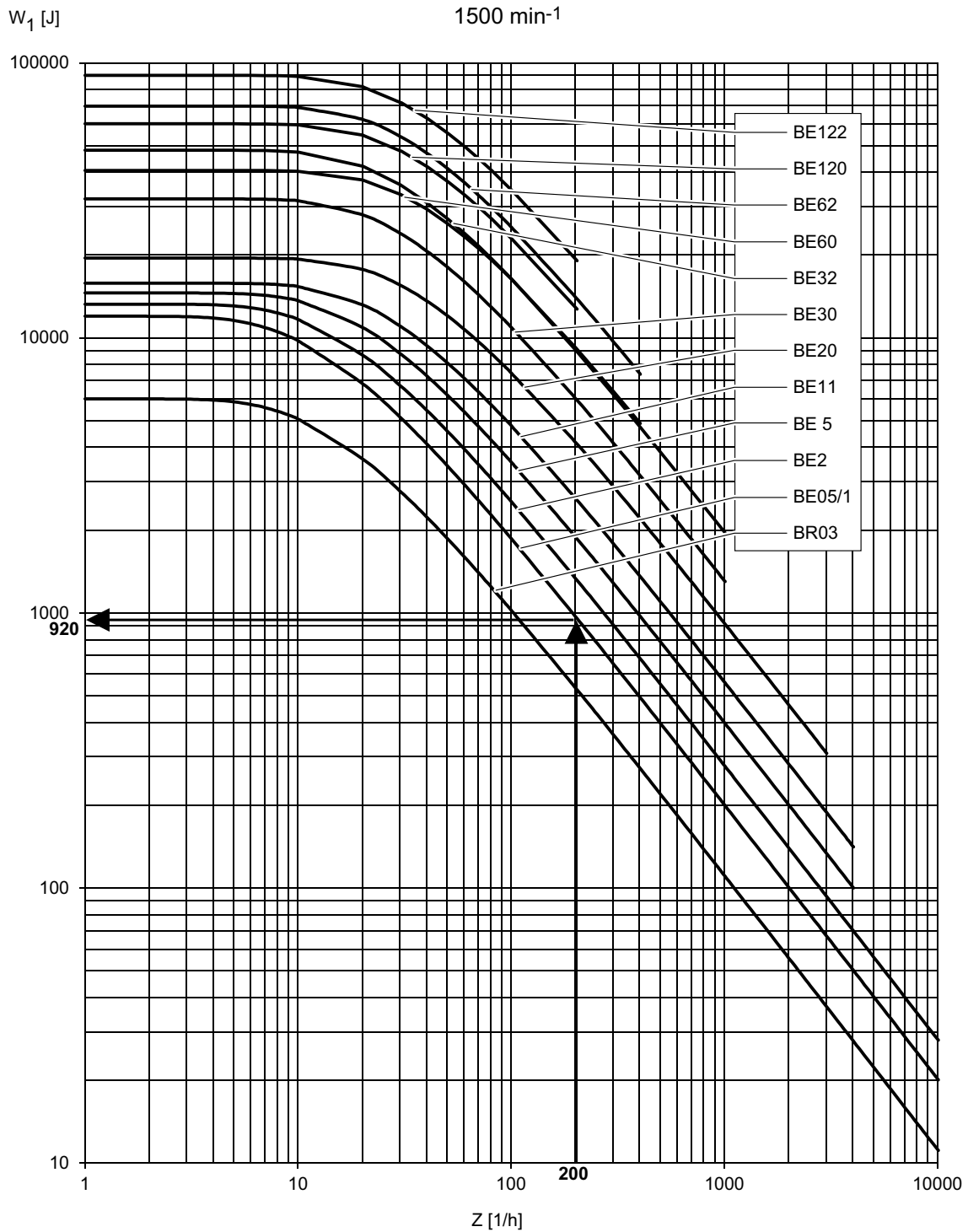

9007203295418507

Example: The rated speed is 1500 rpm and brake BE05 is used. At 200 braking operations per hour, the permitted braking work per braking operation is 920 J.

BE05, BE1, BE2, BE5, BE11, BE20, BE30, BE32, BE60, BE62, BE120, BE122

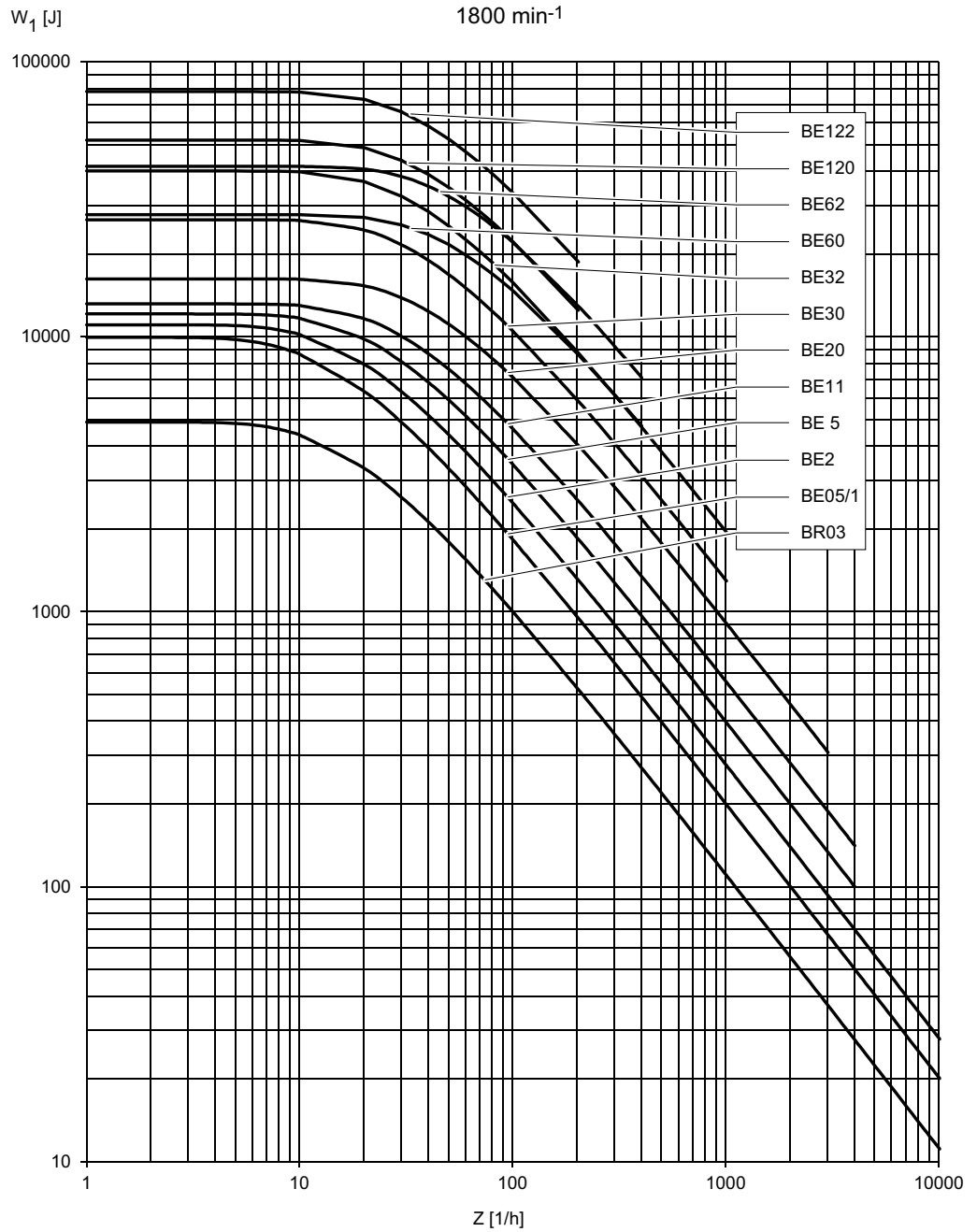

9007204859134603

INFORMATION



Braking operations of speeds greater than 1800 1/min are not permitted for brakes BE30, BE32, BE60, BE62, BE120 and BE122.

19290411/EN – 10/2014

BE05, BE1, BE2, BE5, BE11, BE20

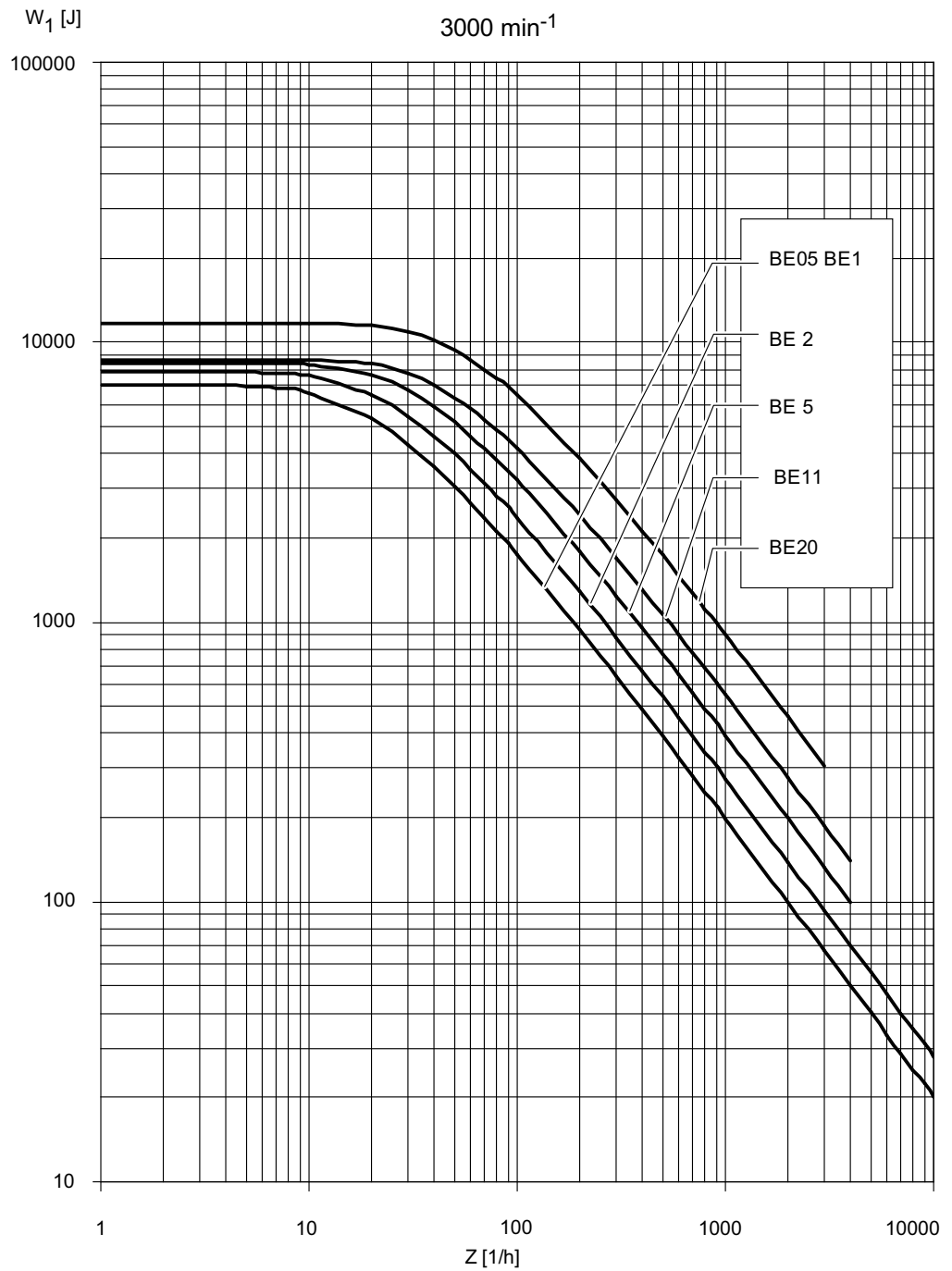

9007203295415819

19290411/EN – 10/2014

BE05, BE1, BE2, BE5, BE11, BE20

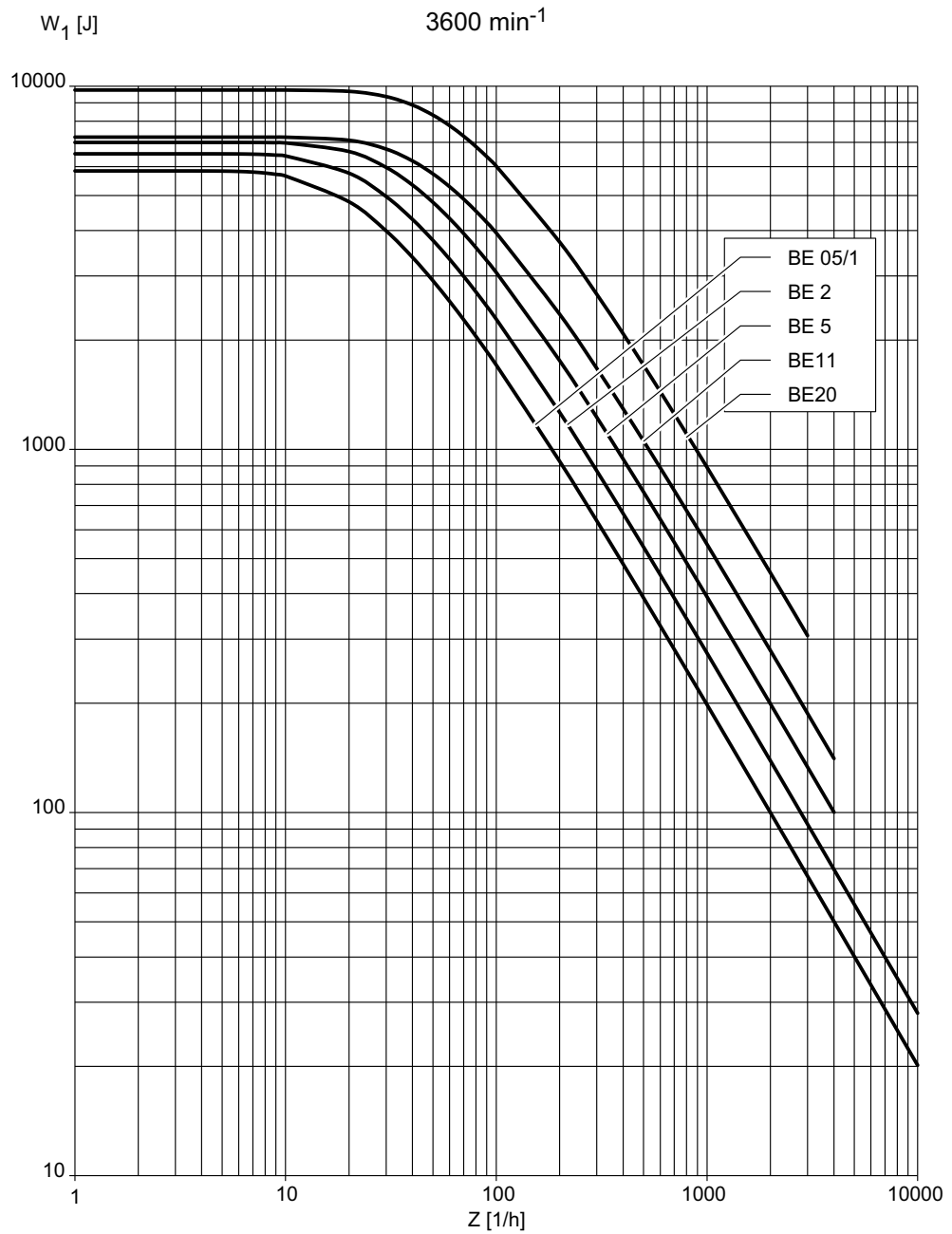

9007204859137419

8.10.3 Permitted braking work of the BE brake in case of emergency switching off

The permitted braking work of our brakes is defined in the known W_{\max}/Z diagrams. In hoists or hoist-like applications the maximum braking work defined here must not be exceeded even in the event of emergency switching off. In contrast, substantially higher values for emergency stop braking can be permitted in applications in travel drives in connection with reduced braking torques, taking the following restrictions into consideration:

- For this type of braking, the actual braking torque can be reduced by up to 60% compared to the normal braking torque.
- The specific wear increases by a factor of a 100 compared to the default value for normal load.
- The rated braking torque must be reduced by at least one stage compared to the maximum nominal braking torque of the assigned brake.

The following diagram and the following table show the maximum permitted braking work under the conditions referred to for emergency stop braking for travel drives depending on the maximum motor speeds.

Diagram: Maximum braking work for emergency switching off for travel drives.

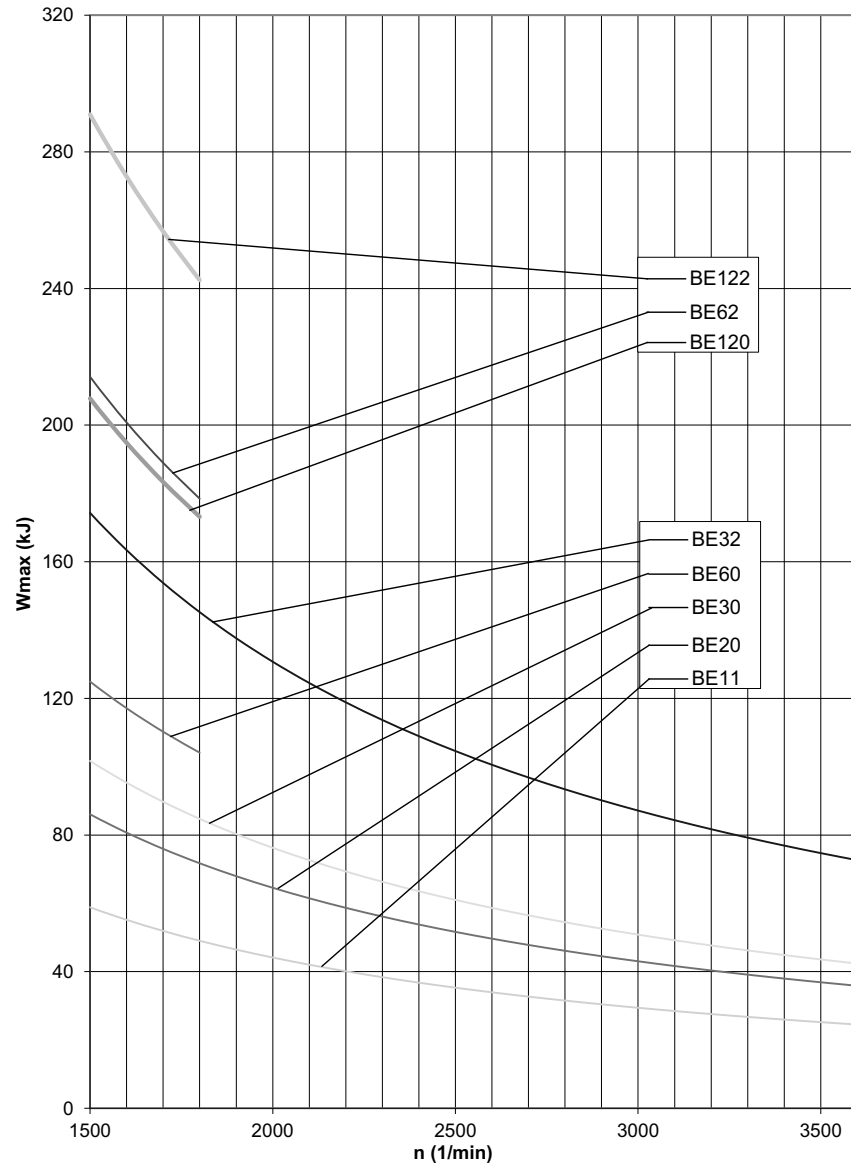

5596208267

If you require increased braking work for travel drive applications with brakes sizes BE05, BE1, BE2 or BE5, then please contact SEW-EURODRIVE.

n in rpm	W _{max} in kJ							
	BE11	BE20	BE30	BE32	BE60	BE62	BE120	BE122
1000	88	129	153	261	187	321	312	436
1100	80	117	139	238	170	292	283	397
1200	74	108	127	218	156	268	260	364
1300	68	99	117	201	144	247	240	336
1400	63	92	109	187	134	229	223	312
1500	59	86	102	174	125	214	208	291
1600	55	81	95	163	117	201	195	273

19290411/EN – 10/2014

n in rpm	W _{max} in kJ							
	BE11	BE20	BE30	BE32	BE60	BE62	BE120	BE122
1700	52	76	90	154	110	189	183	257
1800	49	72	85	145	104	178	173	242
1900	46	68	80	138	–	–	–	–
2000	44	65	76	131	–	–	–	–
2100	42	61	73	125	–	–	–	–
2200	40	59	69	119	–	–	–	–
2300	38	56	66	114	–	–	–	–
2400	37	54	64	109	–	–	–	–
2500	35	52	61	105	–	–	–	–
2600	34	50	59	101	–	–	–	–
2700	33	48	56	97	–	–	–	–
2800	32	46	54	93	–	–	–	–
2900	30	45	53	90	–	–	–	–
3000	29	43	51	87	–	–	–	–
3100	28	42	49	84	–	–	–	–
3200	28	40	48	82	–	–	–	–
3300	27	39	46	79	–	–	–	–
3400	26	38	45	77	–	–	–	–
3500	25	37	44	75	–	–	–	–
3600	25	36	42	73	–	–	–	–

Example: If the application speed is 2000 rpm, with the BE32 brake, the permitted emergency stop braking work per cycle is 135 kJ. Please note the section "Increase emergency switching off work for travel drive applications (→ 358)".

8.10.4 Pulse frequencies of the BE brake

The pulse frequencies of the brake generally depend on many factors, e.g. on the operating temperature of the brakes, the wear condition and the tolerances of the component parts used. A particular factor determining the pulse times is the braking torque set. The following table states guide values for the response times t_1 in operation with (BGE/BME) and without high-speed excitation (BG/BMS) and the application times for switch-off in just the AC circuit (t_{2I}) and DC and AC circuits (t_{2II}).

Brake type	t_1 in 10^{-3} s		t_2 in 10^{-3} s	
	BG/BMS	BGE/BME	t_{2II}	t_{2I}
BE05	34	15	10	42
BE1	55	10	12	76
BE2	73	17	10	68
BE5	-	35	10	70
BE11	-	41	15	82
BE20	-	57	20	88
BE30	-	60	16	80
BE32	-	60	16	80
BE60	-	90	25	120
BE62	-	90	25	120
BE120	-	120	40	130
BE122	-	120	40	130

t_1 = Response time

t_{2I} = Brake application time for cut-off in the AC circuit

t_{2II} = Brake application time for cut-off in the DC and AC circuit

INFORMATION



The times stated are guide values which were determined with the brakes at operating temperature. These may vary under real application conditions.

8.10.5 BE brake – operating currents

The following tables list the operating currents of the brakes at differing voltages.

The acceleration current I_B (= inrush current) flows only for a short time (approx. 160 ms for BE05 – 62, 400 ms for BE120/122) when the brake is released. When using the BG, BS24, or BMS brake controller and direct DC voltage supply without control unit (only possible with brake size BE05 – BE2), increased inrush current does not occur.

The values for the holding currents I_H are r.m.s. values. Only use current measurement units that are designed to measure rms values.

Legend

The following tables list the operating currents of the brakes at differing voltages.

The following values are specified:

- P_B = Electric power consumption in the brake coil in watt.
- U_N = Nominal voltage (nominal voltage range) of the brake in V (AC or DC).
- I_H = Holding current in ampere r.m.s. value of the brake current in the supply cable to the SEW brake control.
- I_G = Direct current in ampere in the brake cable with direct DC voltage supply
or
= Direct current in ampere in the brake cable with DC 24 V supply via BS24, BSG, or BMV.
- I_B = Acceleration current in ampere (AC or DC) when operated with SEW brake controller for high-speed excitation.
- I_B/I_H = Inrush current ratio ESV.
- I_B/I_{DC} = Inrush current ratio ESV for DC 24 V supply with BSG or BMV.

BE05, BE1, BE2 brake

The current values I_H (holding current) listed in the tables are r.m.s. values. Measure the r.m.s. values using only the appropriate measuring instruments. The inrush current (acceleration current) I_B only flows for a short time (ca. 160 ms) when the brake is released. There is no increased inrush current if a BG or BMS brake rectifier is used or if there is a direct DC voltage supply – only possible with brakes up to size BE2.

	BE05, BE1	BE2
Max. braking torque $M_{B\ max}$ in Nm	5/10	20
Braking power P_B in W	32	43
Inrush current ratio ESV	4	4

Rated voltage V_N		BE05, BE1		BE2	
V_{AC}	V_{DC}	I_H A_{AC}	I_G A_{DC}	I_H A_{AC}	I_G A_{DC}
	24 ¹⁾	-	1.17	-	1.53
24 (23-26)	10	2.25	2.90	2.95	3.80
60 (57-63)	24	0.90	1.17	1.18	1.53
120 (111-123)	48	0.45	0.59	0.59	0.77
184 (174-193)	80	0.29	0.37	0.38	0.49
208 (194-217)	90	0.26	0.33	0.34	0.43
230 (218-243)	96	0.23	0.29	0.30	0.39
254 (244-273)	110	0.20	0.26	0.27	0.34
290 (274-306)	125	0.18	0.23	0.24	0.30
330 (307-343)	140	0.16	0.21	0.21	0.27
360 (344-379)	160	0.14	0.18	0.19	0.24
400 (380-431)	180	0.13	0.16	0.17	0.21
460 (432-484)	200	0.11	0.14	0.15	0.19
500 (485-542)	220	0.10	0.13	0.13	0.17
575 (543-600)	250	0.09	0.11	0.12	0.15

1) Operation with control unit BSG, BS24, BMV

BE5, BE11, BE20 brake

The current values I_H (holding current) listed in the tables are r.m.s. values. Measure the r.m.s. values using only the appropriate measuring instruments. The inrush current (acceleration current) I_B only flows for a short time (ca. 160 ms) when the brake is released. A separate voltage supply is not possible.

	BE5	BE11	BE20
Max. braking torque $M_{B\ max}$ in Nm	55	110	200
Braking power P_B in W	49	76	100
Inrush current ratio ESV	5.8	6.7	7.5

Rated voltage V_N		BE5	BE11	BE20
V_{AC}	V_{DC}	I_H A_{AC}	I_H A_{AC}	I_H A_{AC}
	24 ¹⁾	1.67	2.67	3.32
60 (57-63)	-	1.28	2.05	2.55
120 (111-123)	-	0.64	1.04	1.28
184 (174-193)	-	0.41	0.66	0.81
208 (194-217)	-	0.36	0.59	0.72
230 (218-243)	-	0.33	0.52	0.65
254 (244-273)	-	0.29	0.47	0.58
290 (274-306)	-	0.26	0.42	0.51
330 (307-343)	-	0.23	0.37	0.45
360 (344-379)	-	0.21	0.33	0.40
400 (380-431)	-	0.18	0.29	0.36
460 (432-484)	-	0.16	0.26	0.32
500 (485-542)	-	0.15	0.23	0.29
575 (543-600)	-	0.13	0.21	0.26

1) Operation with control unit BSG, BMV

Brakes BE30, BE32, BE60, BE62, BE120, BE122

The current values I_H (holding current) listed in the tables are r.m.s. values. Measure the r.m.s. values using only the appropriate measuring instruments. The inrush current (acceleration current) I_B only flows for a short time (ca. 160 ms) when the brake is released. A separate voltage supply is not possible.

	BE30, BE32	BE60, BE62	BE120, BE122
Max. braking torque $M_{B \max}$ in Nm	300 / 600	1200	1000 / 2000
Braking power P_B in W	130	195	250
Inrush current ratio ESV	8.5	9.2	4.9

Rated voltage V_N	BE30, BE32	BE60, BE62	BE120, BE122
V_{AC}	I_H A_{AC}	I_H A_{AC}	I_H A_{AC}
120 (111-123)	1.66	-	-
184 (174-193)	1.05	-	-
208 (194-217)	0.94	1.5	-
230 (218-243)	0.84	1.35	1.78
254 (244-273)	0.75	1.2	1.59
290 (274-306)	0.67	1.12	1.42
330 (307-343)	0.59	0.97	1.12
360 (344-379)	0.53	0.86	1.0
400 (380-431)	0.47	0.77	0.89
460 (432-484)	0.42	0.68	0.80
500 (485-542)	0.37	0.6	0.71
575 (543-600)	0.33	0.54	1.78

Brake BE120, BE122

The current values I_H (holding current) listed in the tables are r.m.s. values. Measure the r.m.s. values using only the appropriate measuring instruments. The inrush current (acceleration current) I_{AC} only flows for a short time (max. 400 ms) when the brake is released. A separate voltage supply is not possible.

	BE120	BE122
Max. braking torque $M_{B\ max}$ in Nm	1000	2000
Braking power P_B in W	250	250
Inrush current ratio ESV	4.9	4.9

Rated voltage V_N	BE120	BE122
V_{AC}	I_H A_{AC}	I_H A_{AC}
230 (218-243)	1.78	1.78
254 (244-273)	1.59	1.59
290 (274-306)	1.42	1.42
360 (344-379)	1.12	1.12
400 (380-431)	1.0	1.0
460 (432-484)	0.89	0.89
500 (485-542)	0.80	0.80
575 (543-600)	0.71	0.71

8.10.6 Resistance brake coils

BE05, BE1, BE2 brake

	BE05, BE1	BE2
Max. braking torque $M_{B\ max}$ in Nm	5/10	20
Braking power P_B in W	32	43
Inrush current ratio ESV	4	4

Rated voltage V_N		BE05, BE1		BE2	
V_{AC}	V_{DC}	R_B	R_T	R_B	R_T
–	24 ¹⁾	4.9	14.9	3.60	11
24 (23-26)	10	0.78	2.35	0.57	1.74
60 (57-63)	24	4.9	14.9	3.60	11
120 (111-123)	48	19.6	59	14.4	44
184 (174-193)	80	49	149	36	110
208 (194-217)	90	62	187	45.5	139
230 (218-243)	96	78	235	58	174
254 (244-273)	110	98	295	72	220
290 (274-306)	125	124	375	91	275
330 (307-343)	140	156	470	115	350
360 (344-379)	160	196	590	144	440
400 (380-431)	180	245	750	182	550
460 (432-484)	200	310	940	230	690
500 (485-542)	220	390	1180	280	860
575 (543-600)	250	490	1490	355	1080

1) Operation with control unit BSG, BS24, BMV

BE5, BE11, BE20 brake

	BE5	BE11	BE20
Max. braking torque $M_{B \max}$ in Nm	55	110	200
Braking power P_B in W	49	76	100
Inrush current ratio ESV	5.8	6.7	7.5

Rated voltage V_N		BE5		BE11		BE20	
V_{AC}	V_{DC}	R_B	R_T	R_B	R_T	R_B	R_T
-	24 ¹⁾	2.20	10.5	1.22	6.9	0.85	5.7
60 (57-63)	24	2.20	10.5	1.22	6.9	0.85	5.7
120 (111-123)	-	8.70	42	4.9	27.5	3.4	22.5
184 (174-193)	-	22	105	12.3	69	8.5	57
208 (194-217)	-	27.5	132	15.5	87	10.7	72
230 (218-243)	-	34.5	166	19.5	110	13.5	91
254 (244-273)	-	43.5	210	24.5	138	17	114
290 (274-306)	-	55	265	31	174	21.5	144
330 (307-343)	-	69	330	39	220	27	181
360 (344-379)	-	87	420	49	275	34	230
400 (380-431)	-	110	530	62	345	42.5	285
460 (432-484)	-	138	660	78	435	54	360
500 (485-542)	-	174	830	98	550	68	455
575 (543-600)	-	220	1050	119	670	85	570

1) Operation with control unit BSG, BMV

Brakes BE30, BE32, BE60, BE62

	BE30, BE32	BE60, BE62
Max. braking torque $M_{B \max}$ in Nm	300 / 600	600/1200
Braking power P_B in W	130	195
Inrush current ratio ESV	8.5	9.2

Rated voltage V_N	BE30, BE32		BE60, BE62	
V_{AC}	R_B	R_T	R_B	R_T
120 (111-123)	2.3	17.2	-	-
184 (174-193)	5.8	43	-	-
208 (194-217)	7.3	54	3.95	32.5
230 (218-243)	9.2	69	5	41
254 (244-273)	11.6	86	6.3	52
290 (274-306)	14.6	109	5.6	64
330 (307-343)	18.3	137	9.9	80
360 (344-379)	23	172	12.6	101
400 (380-431)	29	215	15.8	128
460 (432-484)	36.5	275	19.9	163
500 (485-542)	46	345	25.5	205
575 (543-600)	58	430	31.5	260

Brake BE120, BE122

		BE120, BE122	
Max. braking torque $M_{B \max}$ in Nm		1000 / 2000	
Braking power P_B in W		250	
Inrush current ratio ESV		4.9	
Rated voltage V_N		BE120, BE122	
V_{AC}		R_B	R_T
230 (218-243)		8	29.9
254 (244-273)		10.1	37.6
290 (274-306)		12.7	47.4
360 (344-379)		20.1	75.1
400 (380-431)		25.3	94.6
460 (432-484)		31.8	119
500 (485-542)		40.1	149.9
575 (543-600)		50.5	188.7

8.10.7 Actuating force for manual brake release

In brakemotors with ..HR variant "Manual brake release with automatic reengaging function," you can release the brake manually using the lever supplied. The following table specifies the actuation force required at maximum braking torque to release the brake by hand. The values are based on the assumption that you operate the lever at the upper end. The length of that part of the manual lever projecting out of the fan guard is stated as well.

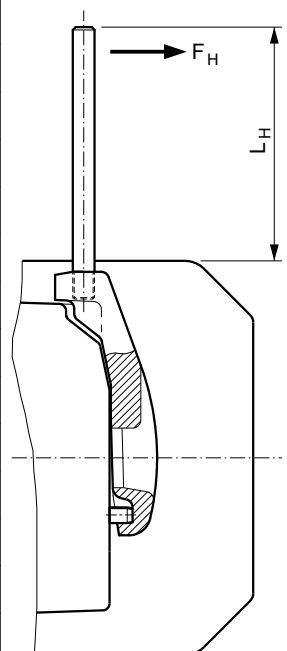
Brake type	Motor size	Actuation force F_H in N ¹⁾	Lever length L_H in mm	
BE05	71	20	80	
BE05	80	20	71	
BE1	71	40	80	
BE1	80	40	71	
BE1	90/100	40	57	
BE2	80	80	82	
BE2	90/100	80	67	
BE5	90/100	215	87	
BE5	112/132	215	70	
BE11	112/132	300	120	
BE11	160	300	96	
BE20	160	375	178	
BE20	180	375	150	
BE30/32	180	400	235	
BE30/32	200/225	400	216	
BE60/62	200/225	500	416	
BE60/62	250/280	500	358	

1) Tolerance of operating force: -10 % to +30 %

8.10.8 Brake control block diagrams

Legend

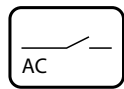

Cut-off in the AC circuit
(normal application of the brake)

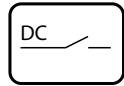

Cut-off in the DC circuit
(rapid application of the brake)

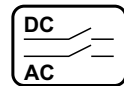

Cut-off in the DC and AC circuits
(rapid application of the brake)

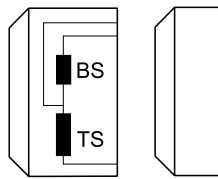

Brakes
BS = accelerator coil
TS = coil section

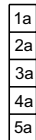

Auxiliary terminal strip in terminal box



Motor with delta connection



Motor with star connection

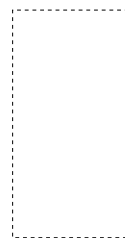

Control cabinet limit

3985837195

WH	White
RD	red
BU	blue
BN	Brown
BK	Black

BG brake control

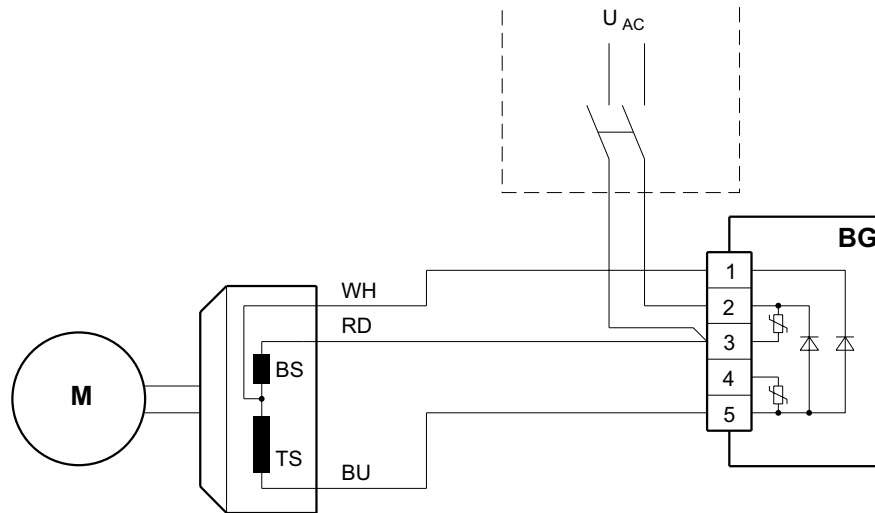
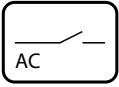

3985840267

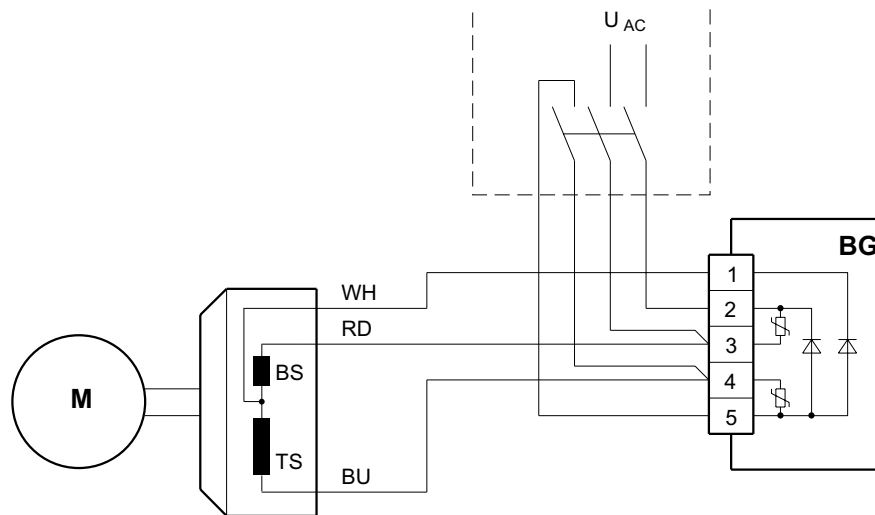
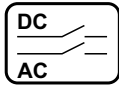

3985842315

BGE brake control

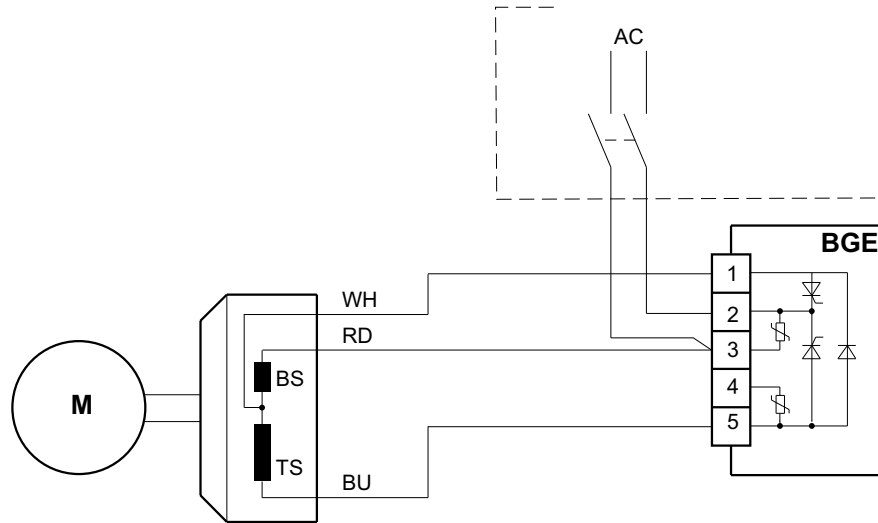
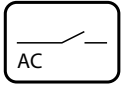

3985850507

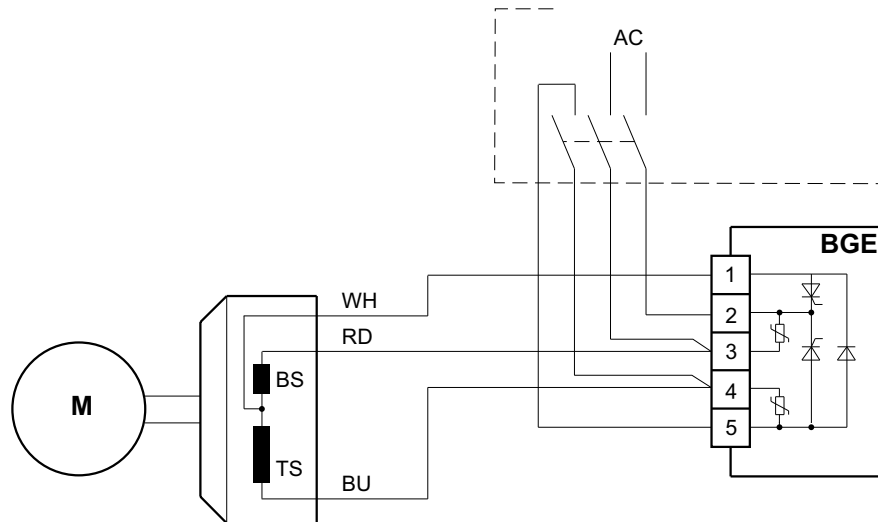
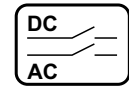

3985852555

8

BS brake control

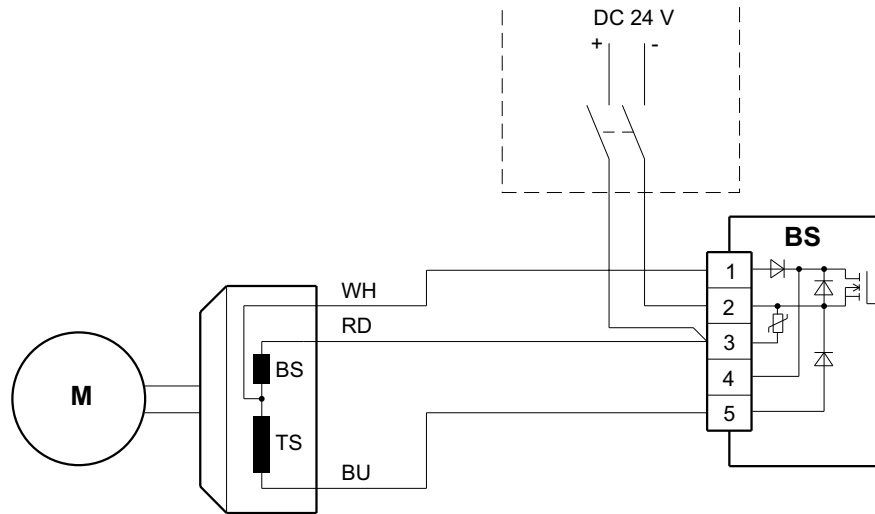
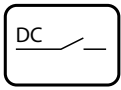

5465000459

BSG brake control

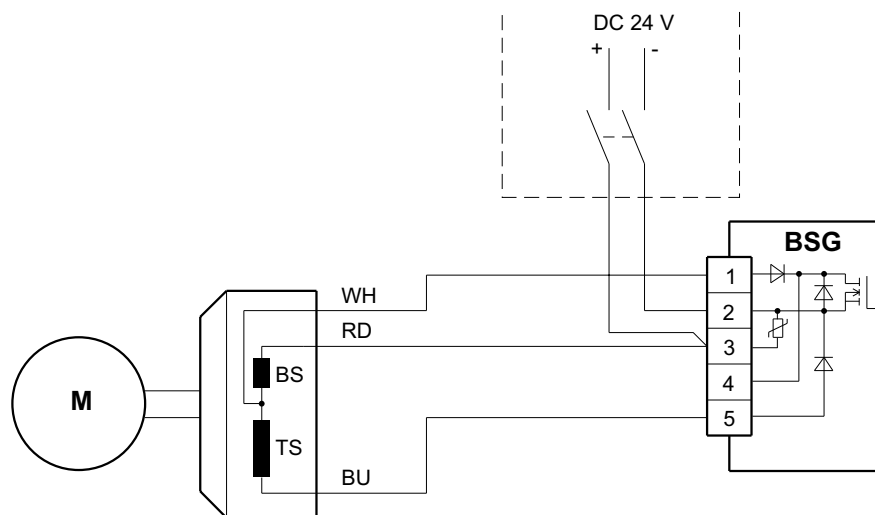
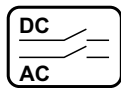

3985870219

BSR brake control

Brake voltage = Phase voltage

Example: Motor 230 V Δ / 400 V Y , brake AC 230 V

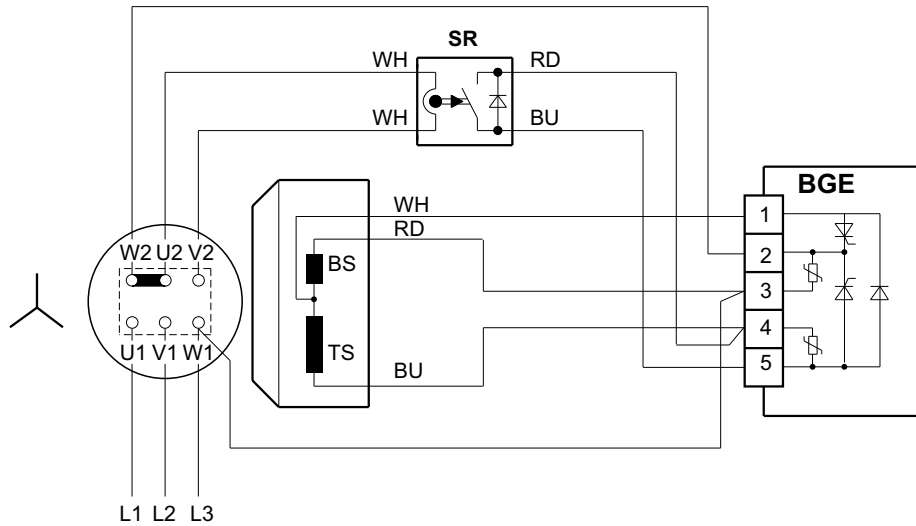
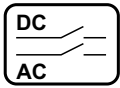

3985860747

Example: Motor 400 V Δ / 690 V Y , brake: AC 400 V

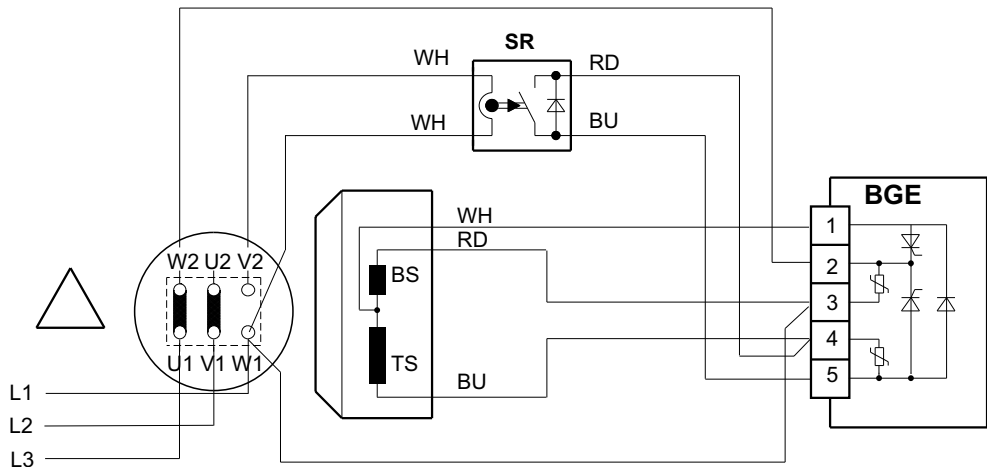
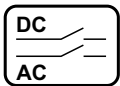

3985862411

Brake voltage = Phase-to-phase voltage

The input voltage of the brake rectifier corresponds to the line voltage of the motor, e.g. motor: 400 V Δ , brake: AC 400 V

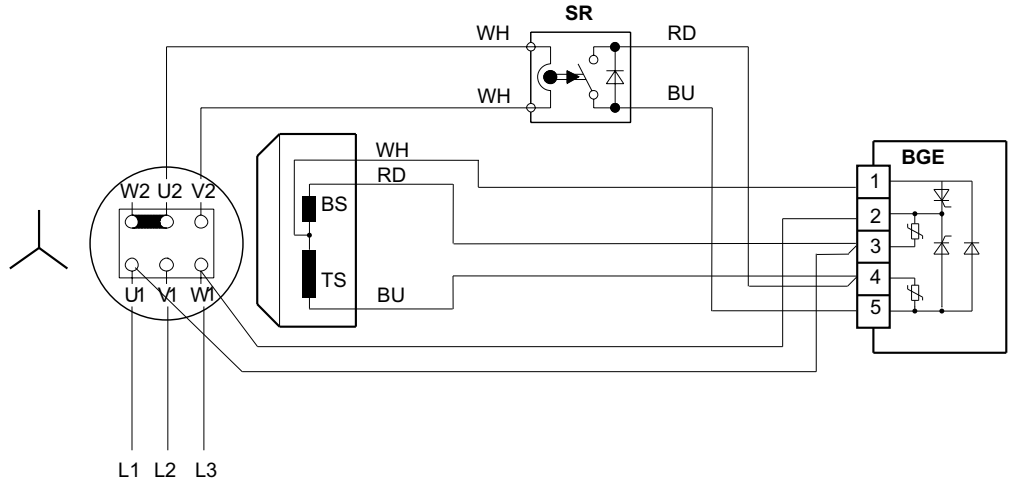
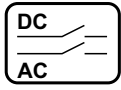

3985864075

BUR brake control

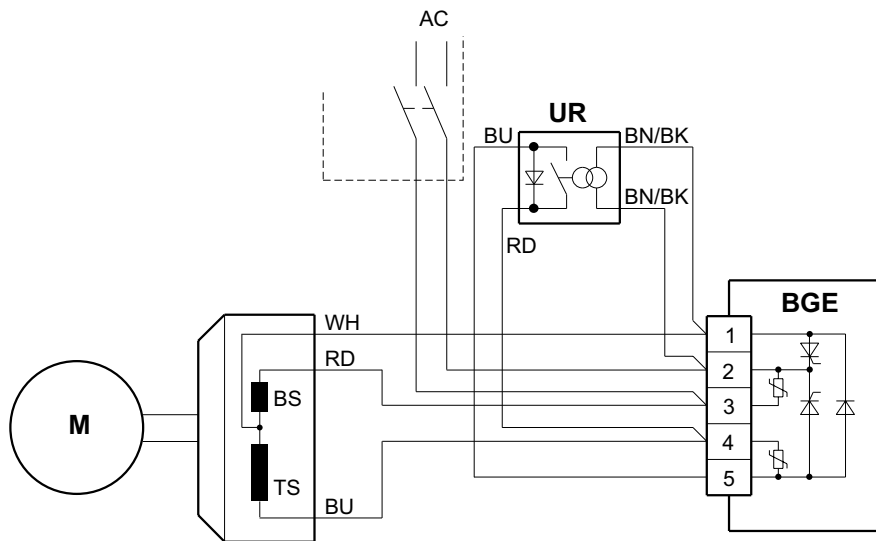
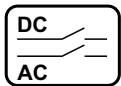

3985867147

BMS brake control

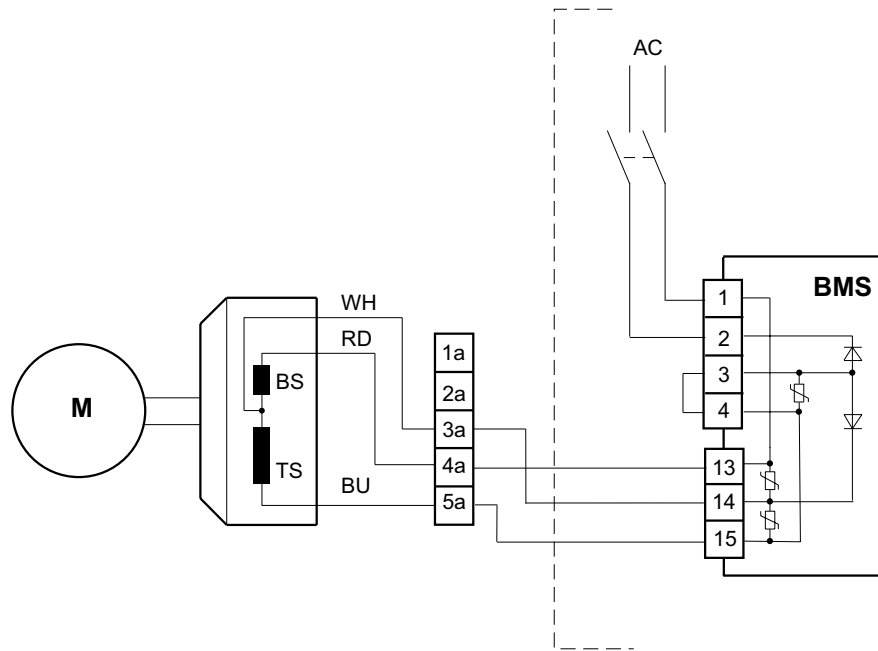
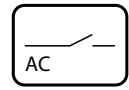

3985845387

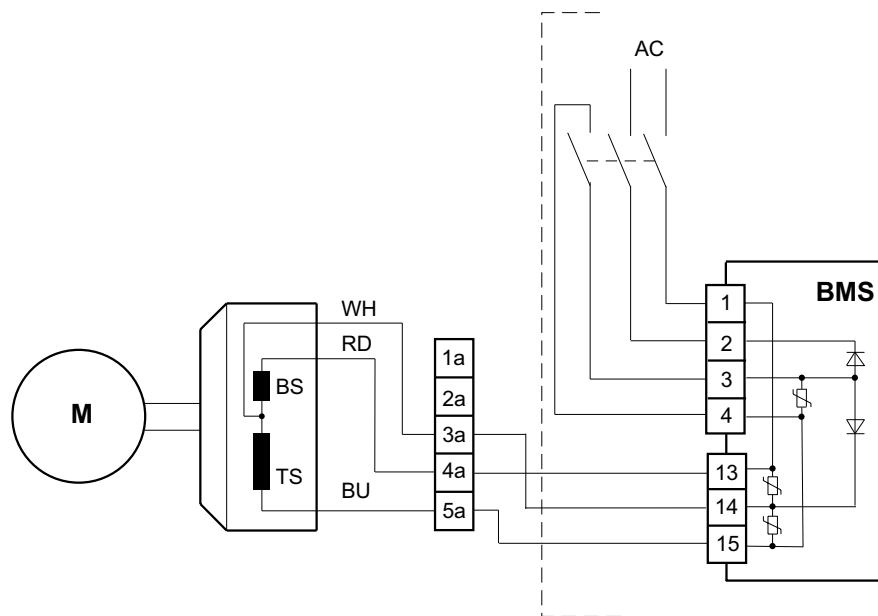
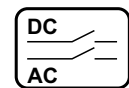

3985847435

BME brake control

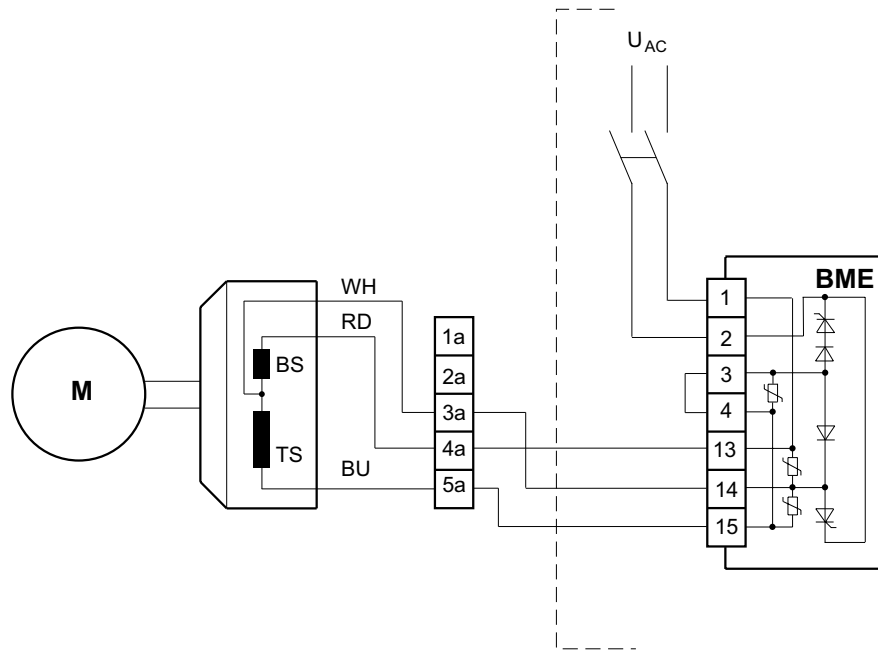
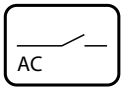

3985855627

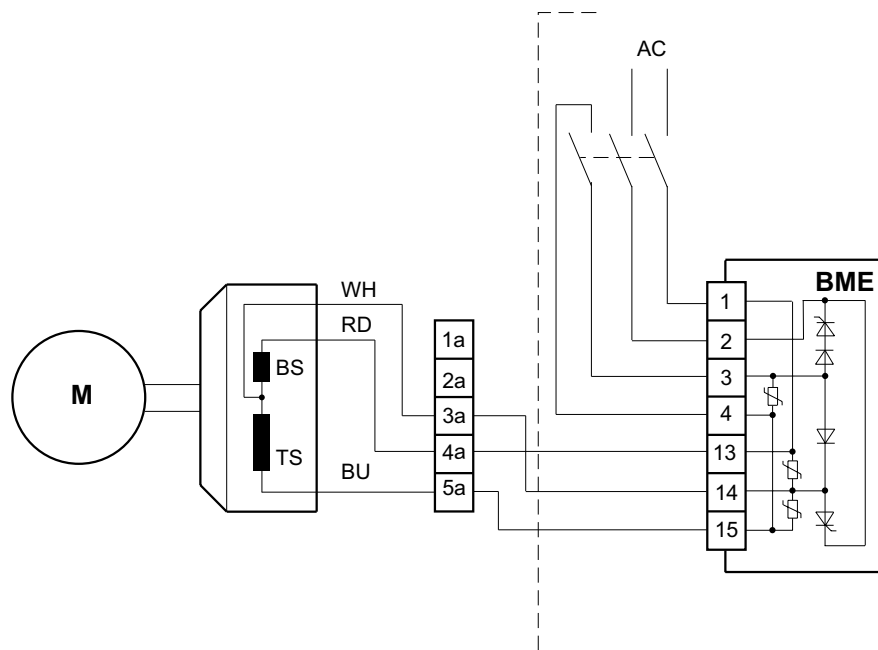
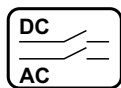

3985857675

BMP brake control

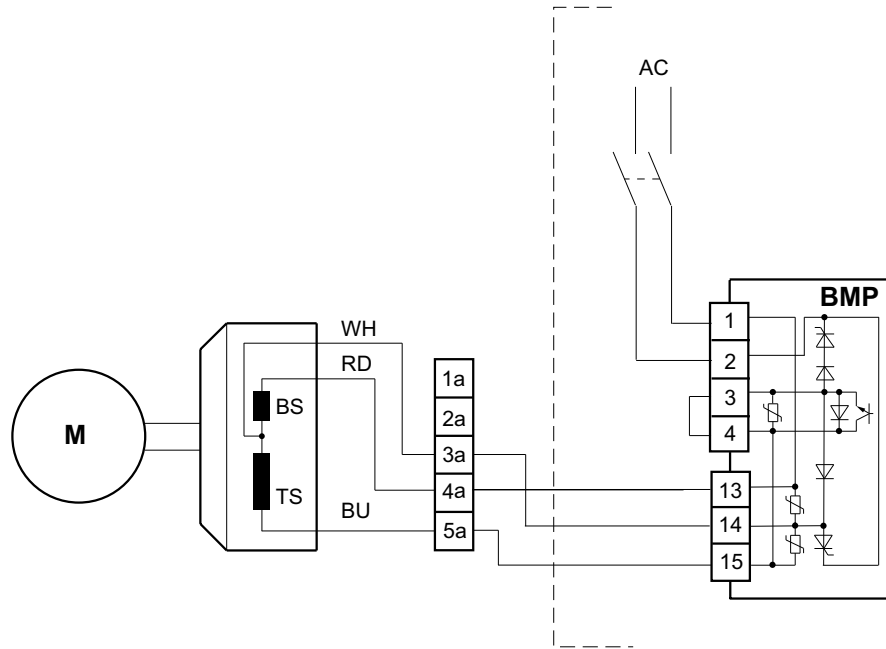
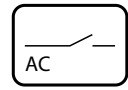

3985873291

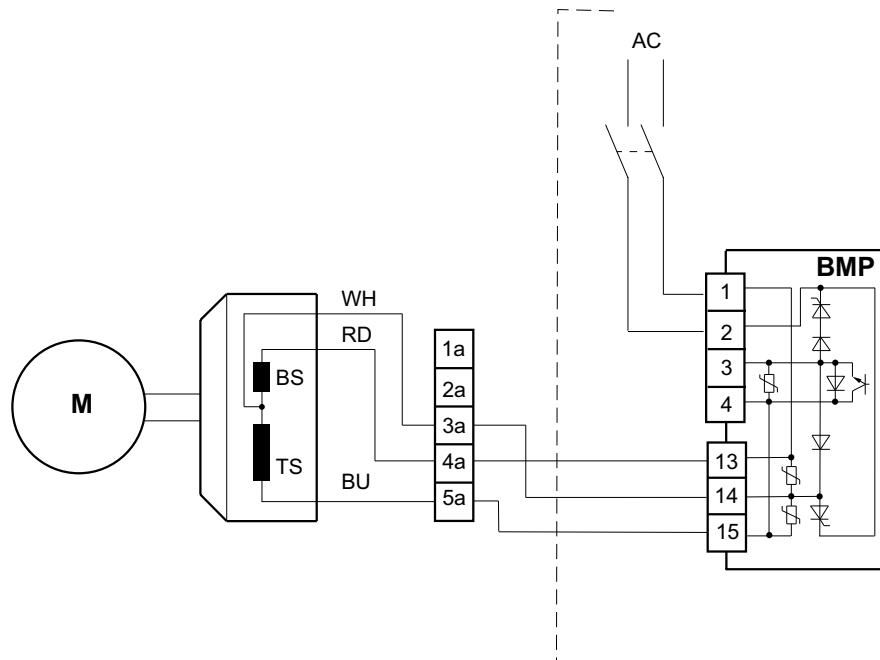
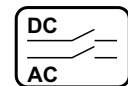

3985875339

BMP 3.1 brake control (motor)

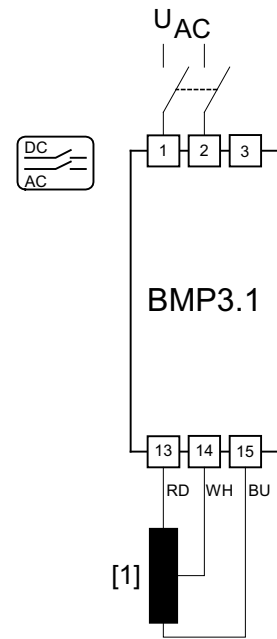
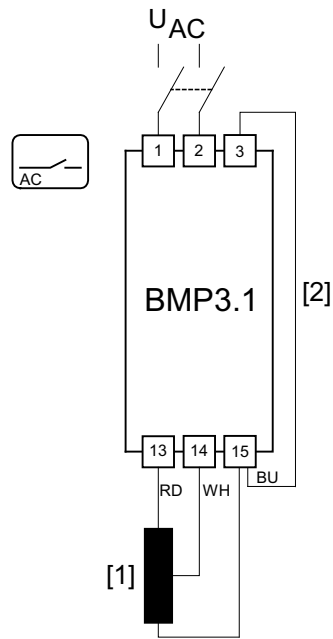

3985878027

[1] Brake coil

[2] Jumper

BMP 3.1 brake control (control cabinet)

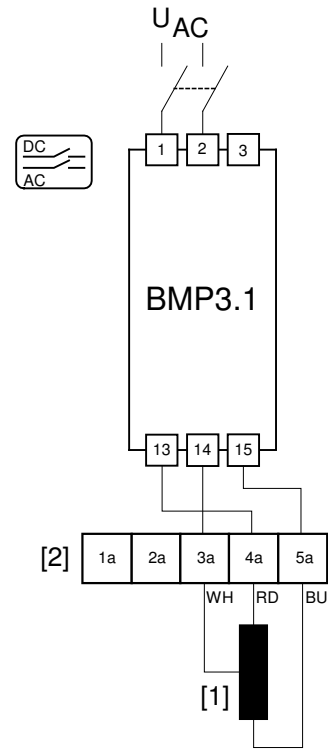
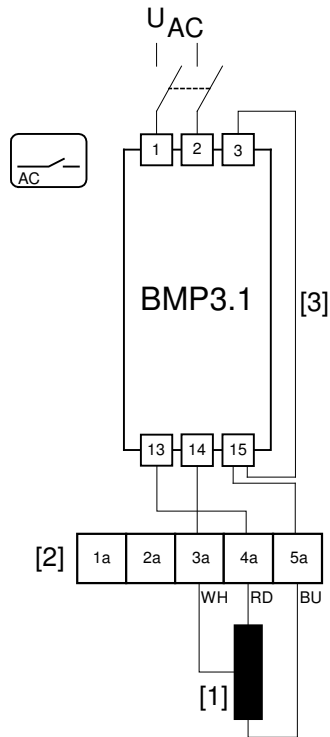

3985880715

- [1] Brake coil
- [2] Terminal strip
- [3] Jumper

INFORMATION



There is no need for the jumper in alternating current operation (AC) if connection 5a is wired directly to connection 3.

BMH brake control

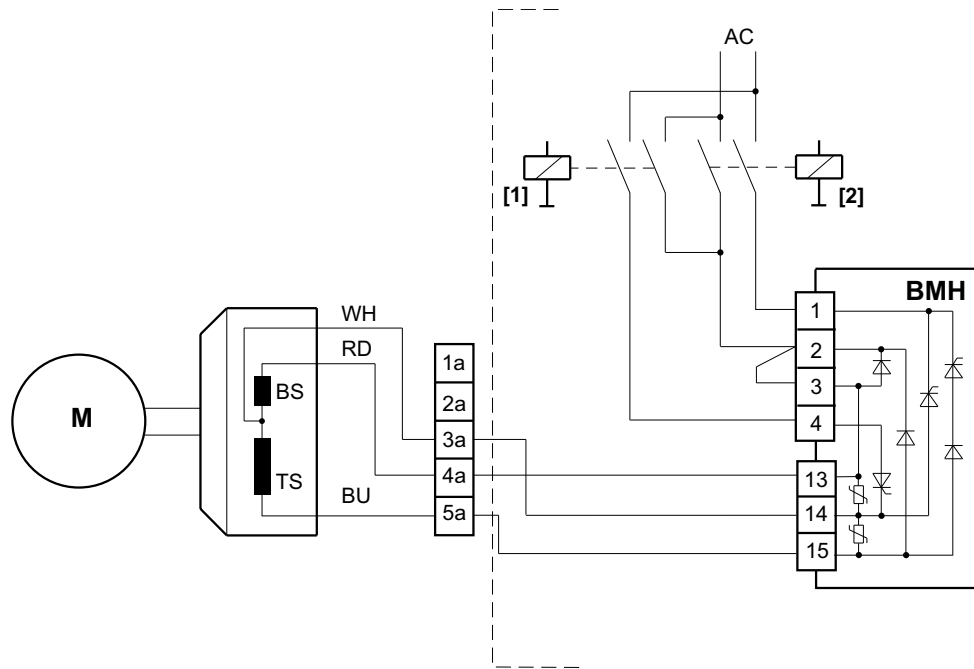
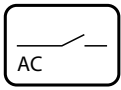

3985883787

- [1] Heating
- [2] Release

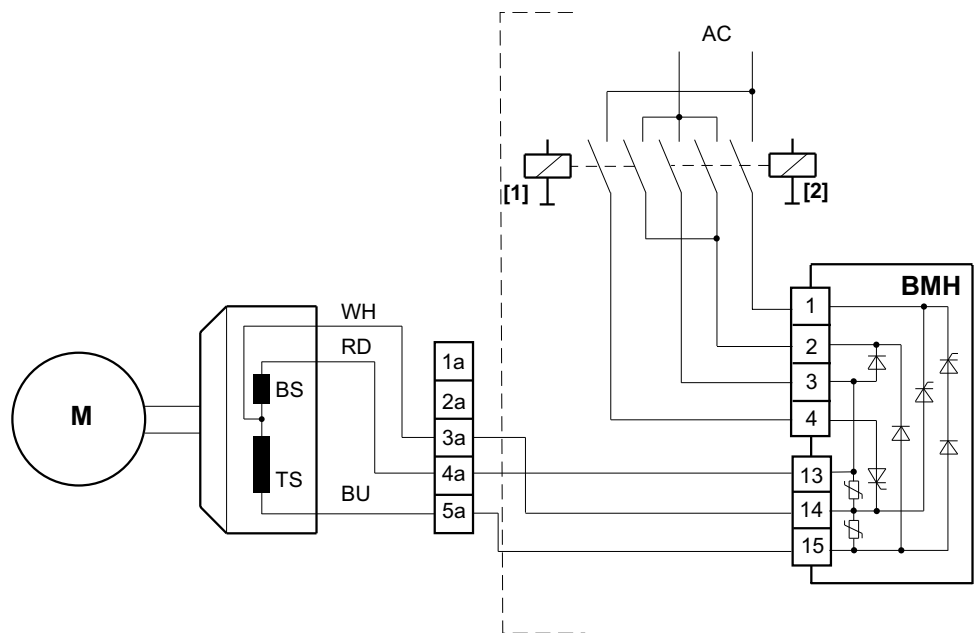
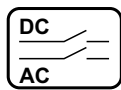

3985885835

- [1] Heating
- [2] Release

BMK brake control

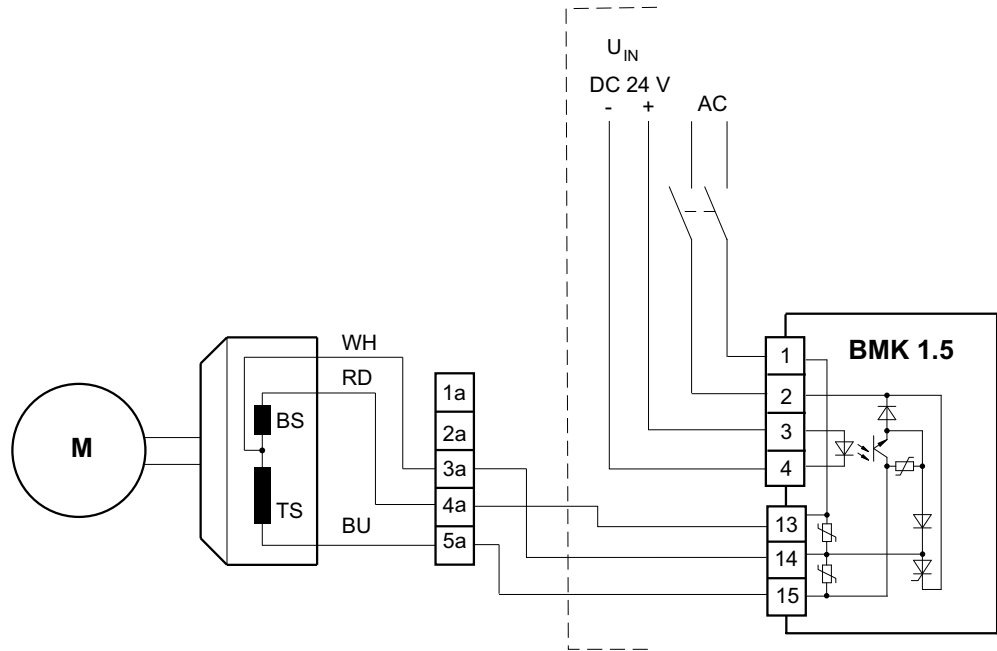
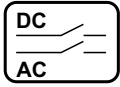

3985888907

BMV brake control

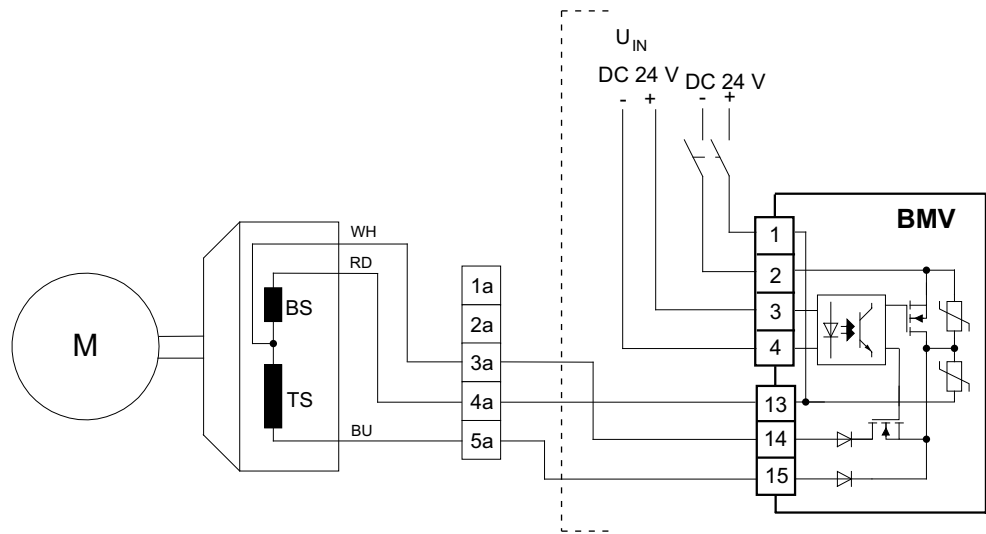
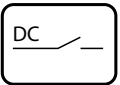

3985891979

V_{IN} = control signal

8.10.9 Dimension sheets brake controls

BG, BGE, BS, BSG

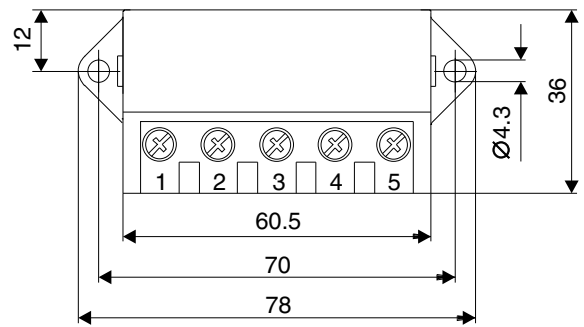
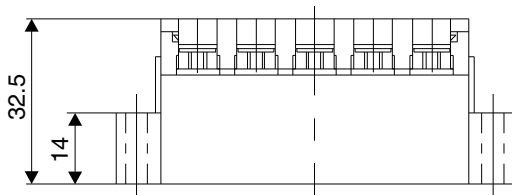

4040861323

Auxiliary terminal strip

For connection of the brake coil or TF/TH and strip heaters in the wiring space of the motor

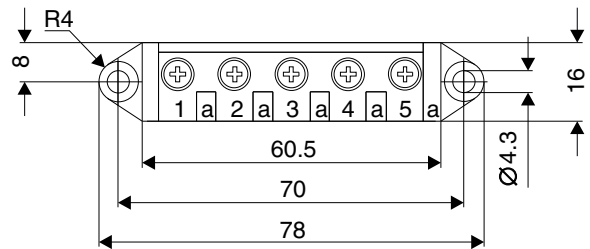
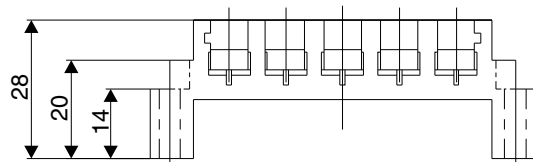

4040864011

SR10, SR11, SR15, UR11, UR15

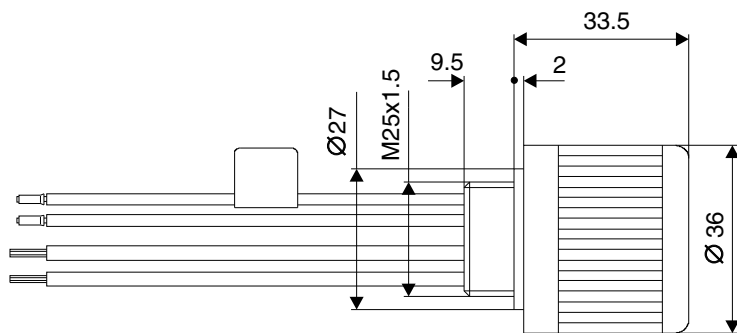

4040892299

SR19

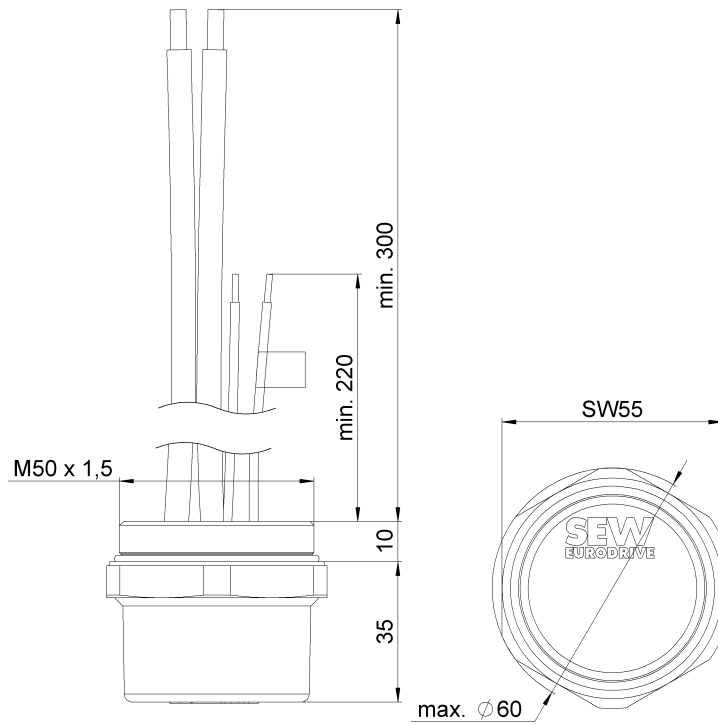

5636837259

BMS, BME, BMH, BMP, BMK, BMV

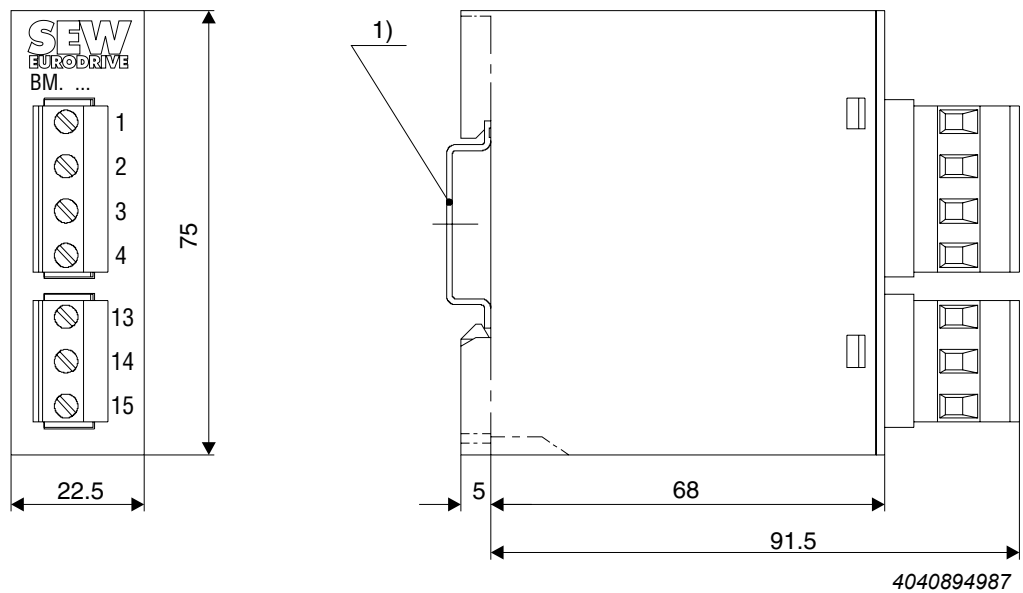

4040894987

[1] Support rail mounting EN 50022-35-7.5

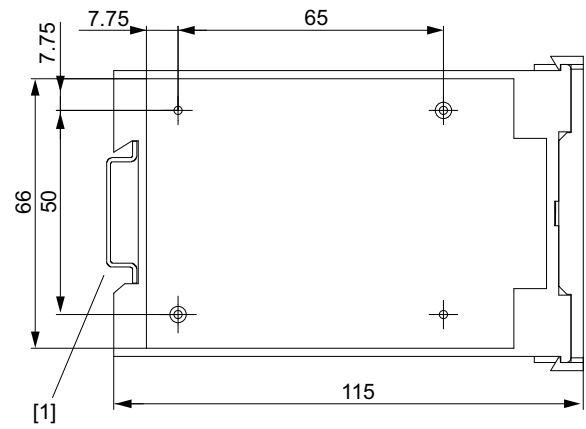
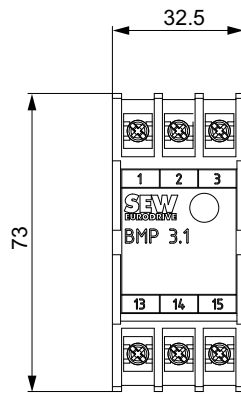
BMP3.1

4040897675

8.11 The safety-rated BE brake

8.11.1 Description

If necessary, the BE brake can also be delivered in a safety-rated design on the DR..motor.

The design is based on the regulations contained in EN 13849.

With a safety-rated brake, you can realize the following safety functions that force a standstill of a drive and safely hold the drive in its position.

- SBA (safe brake actuation)
- SBH (safe brake hold)

Performance Level

Safety-rated BE..(FS) brakes are a component in a safe braking system. The performance level of the safe brake system that can be achieved is influenced by the following factors:

- the selected safety architecture, i.e. the category according to EN ISO 13849
- how often the systems are used in the application (B10d, MTTFd)
- an available brake diagnosis (DC)
- the application in which the safe brake system is used (horizontal or vertical application).

BE brake compared to safety-rated BE brake (FS)

The table below shows the basic differences between the standard brake and the safety-rated BE brake.

	Standard BE brake	Safety-rated BE brake
Brake sizes	BE05 to BE122	BE05 to BE32
Holding brake	Yes	Yes (with emergency switching off properties)
Working brake	Yes	No
Braking torques	All	Restrictions (depending on the mounting position)
Manual brake release	HF: Yes HR: Yes	HF: No HR: Yes, retrofitting not permitted
DC direct voltage supply	Yes	No
Maintenance by the customer	Yes	No
Air gap adjustable	Yes	No
DR..motor design	All	DRS., DRE., DRP., DRL..
Number of poles	All	2-, 4-, 6-pole are permitted
Approval according to directive 94/9/EC	Yes, in cat. 3 (for zone 2 / 22)	No
In combination with MOVIMOT®	Yes	Contact SEW-EURODRIVE
In combination with MOV-SWITCH®	Yes	No
In combination with motor protection /TF	Optional	Mandatory

19290411/EN – 10/2014

8

BE brake

The safety-rated BE brake

	Standard BE brake	Safety-rated BE brake
In combination with motor protection /TH	Optional	No
In combination with flywheel fan /Z	Optional	Restrictions for DR.90/100 with BE5
Mounting position	All	Restrictions for permitted braking torques
Category	B	1
B10d value	-	Specification per size

INFORMATION



All the other components such as the gear unit type, suitable ratio i , service factor f_B , load change, output shaft, etc. must be selected by the customer.

8.11.2 Notes on the project planning for the safety-rated BE brake

Definition of the categories

The categories classify safety-related components regarding their resistance to errors and their response in the event of an error based on the reliability and/or the structural arrangement of the parts. A higher resistance to errors means a higher potential to reduce risk.

Brake type	Category
BE.. brake without safety rating	Category B (according to EN ISO 13849)
Safety characteristics BE.. brake (FS)	Category 1 (according to EN ISO 13849)

8.11.3 Braking work, working air gap, braking torques of the BE.. brakes (FS)

The following table lists the data for setting the BE.. brake (FS):

Brakes	Braking work until maintenance	Working air gap		Braking torques ¹⁾
	in 10 ⁶ J	in mm		in Nm (lb-in)
		min. ²⁾	max.	
BE05	120	0.25	0.6	5.0 (44) 3.5 (31) 2.5 (22) 1.8 (16)
BE1	120	0.25	0.6	10 (88.5) 7.0 (62) 5.0 (44)
BE2	165	0.25	0.6	20 (177) 14 (124) 10 (88.5) 7.0 (62) 5.0 (44)
BE5	260	0.25	0.7	55 (487) 40 (354) 28 (248) 20 (177) 14 (124)
BE11	285	0.3	0.7	110 (974) 80 (708) 55 (487) 40 (354)
BE20	445	0.3	0.7	200 (1770) 150 (1328) 110 (974) 80 (708) 55 (487)
BE30	670	0.3	0.7	300 (2655) 200 (1770) 150 (1328) 100 (885) 75 (667)
BE32	670	0.4	0.8	600 (5310) 500 (4425) 400 (3540) 300 (2655) 200 (1770) 150 (1328)

1) The braking torques are subject to a tolerance of -10% to +50 %.

2) When checking the working air gap, note: Parallelism tolerances on the brake disk may give rise to deviations of ±0.15 mm after a test run.

8.11.4 Permitted maximum braking work for emergency switching off for BE..(FS)

The permitted maximum braking work for emergency switching off for BE..(FS) is valid up to max. 10 switching cycles per hour for travel and hoist applications.

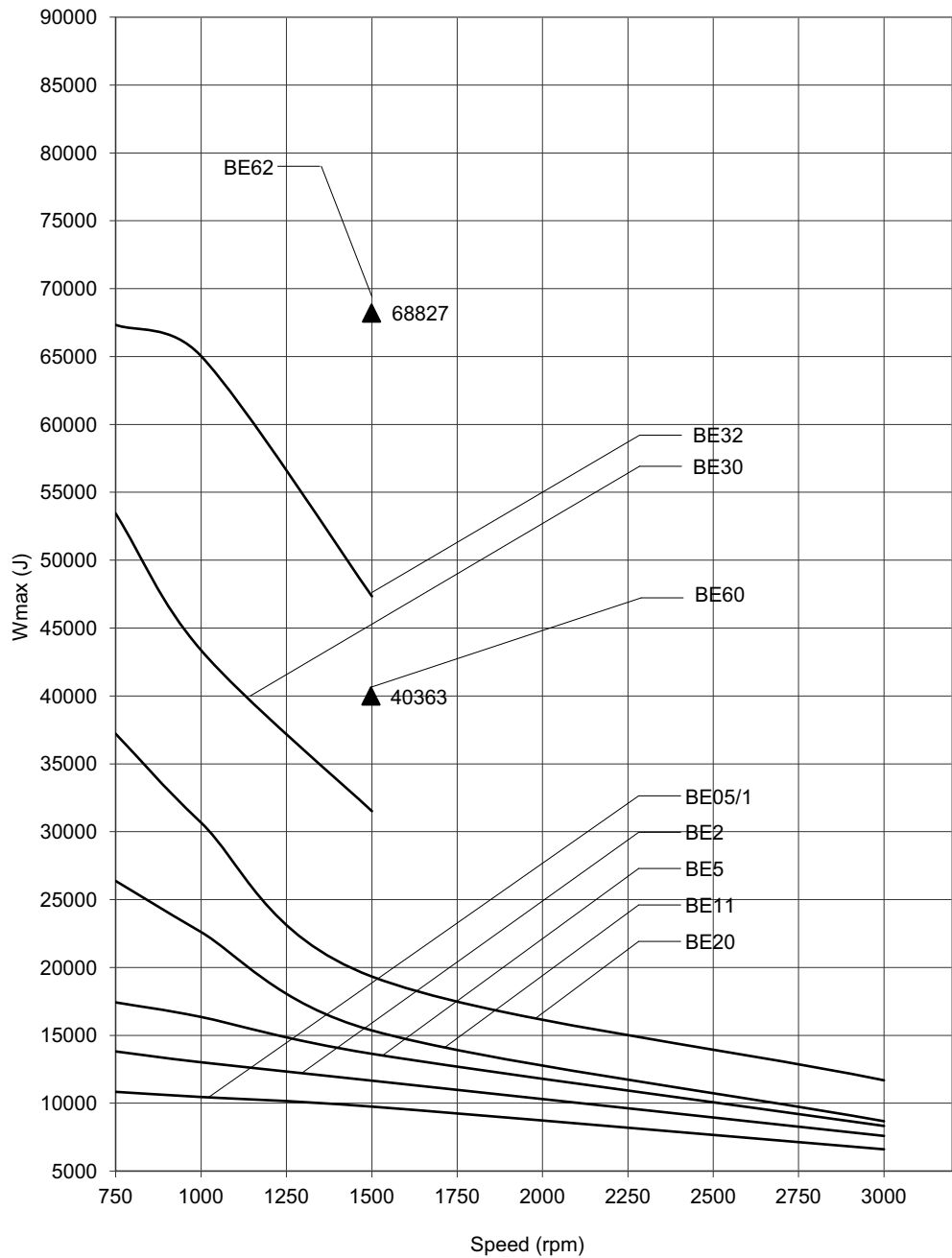

9007204858815499

8.11.5 Permitted braking work for emergency switching off for brakes BE11, BE20, BE30, BE32 on horizontal drives

The permitted braking work of our brakes is defined in the known W_{\max}/Z diagrams. In hoists or hoist-like applications the maximum braking work defined here must not be exceeded even in the event of emergency switching off. In contrast, substantially higher values for emergency switching off braking can be permitted in applications in travel drives in connection with reduced braking torques, taking the following restriction into consideration:

- For this type of braking, the actual braking torque can be reduced by the factor f_M compared to the normal braking torque:

$$M_B = f_M \times M_{B \text{ nominal}}$$

- The specific wear increases by the factor f_v , compared to the default value for normal load. This gives the number of cycles until servicing:

$$Z_B = W_{\text{insp}} / (W_1 \times f_v)$$

- The rated braking torque must be reduced by at least one stage compared to the maximum braking torque of the assigned brake.

The following tables and diagrams show the maximum permitted braking work under the conditions referred to for emergency stop braking for travel drives depending on the maximum motor speeds.

Friction characteristics are stable up to limit curve A. The overload range begins above limit curve A and the reproducibility of results decreases. The limit curves specified can therefore only be considered as benchmark values.

Limit curve A:

The catalog specifications apply for braking underneath this curve for the total braking work until inspection (e.g. for BE20: $W_{\text{insp}} = 1000 \text{ MJ}$).

Limit curve B:

For the area between curve A and curve B, W_{insp} must be divided by a factor of 10. The braking torque reduces to 80 % of the nominal value.

Limit curve C:

For the area between curve B and curve C, W_{insp} must be divided by a factor of 50. The braking torque reduces to 70 % of the nominal value.

Limit curve D:

For the area between curve C and curve D, W_{insp} must be divided by a factor of 100. The braking torque reduces to 60 % of the nominal value.

BE11 brakeValue table W_{max} BE11:

n in rpm	Limit curve A	Limit curve B	Limit curve C	Limit curve D
	BE11 ($f_v = 1 / f_M = 1$)	BE11 ($f_v = 10 / f_M = 0.8$)	BE11 ($f_v = 50 / f_M = 0.7$)	BE11 ($f_v = 100 / f_M = 0.6$)
1000	32	53	76	88
1100	29	48	70	80
1200	27	44	64	74
1300	25	41	59	68
1400	23	38	55	63
1500	22	35	51	59
1600	20	33	48	55
1700	19	31	45	52
1800	18	29	42	49
1900	17	28	40	46
2000	16	26	38	44
2100	15	25	36	42
2200	15	24	35	40
2300	14	23	33	38
2400	13	22	32	37
2500	13	21	31	35
2600	12	20	29	34
2700	12	20	28	33
2800	12	19	27	32
2900	11	18	26	30
3000	11	18	25	29
3100	10	17	25	28
3200	10	17	24	28
3300	10	16	23	27
3400	10	16	22	26
3500	9	15	22	25
3600	9	15	21	25

Diagram W_{max} BE11:

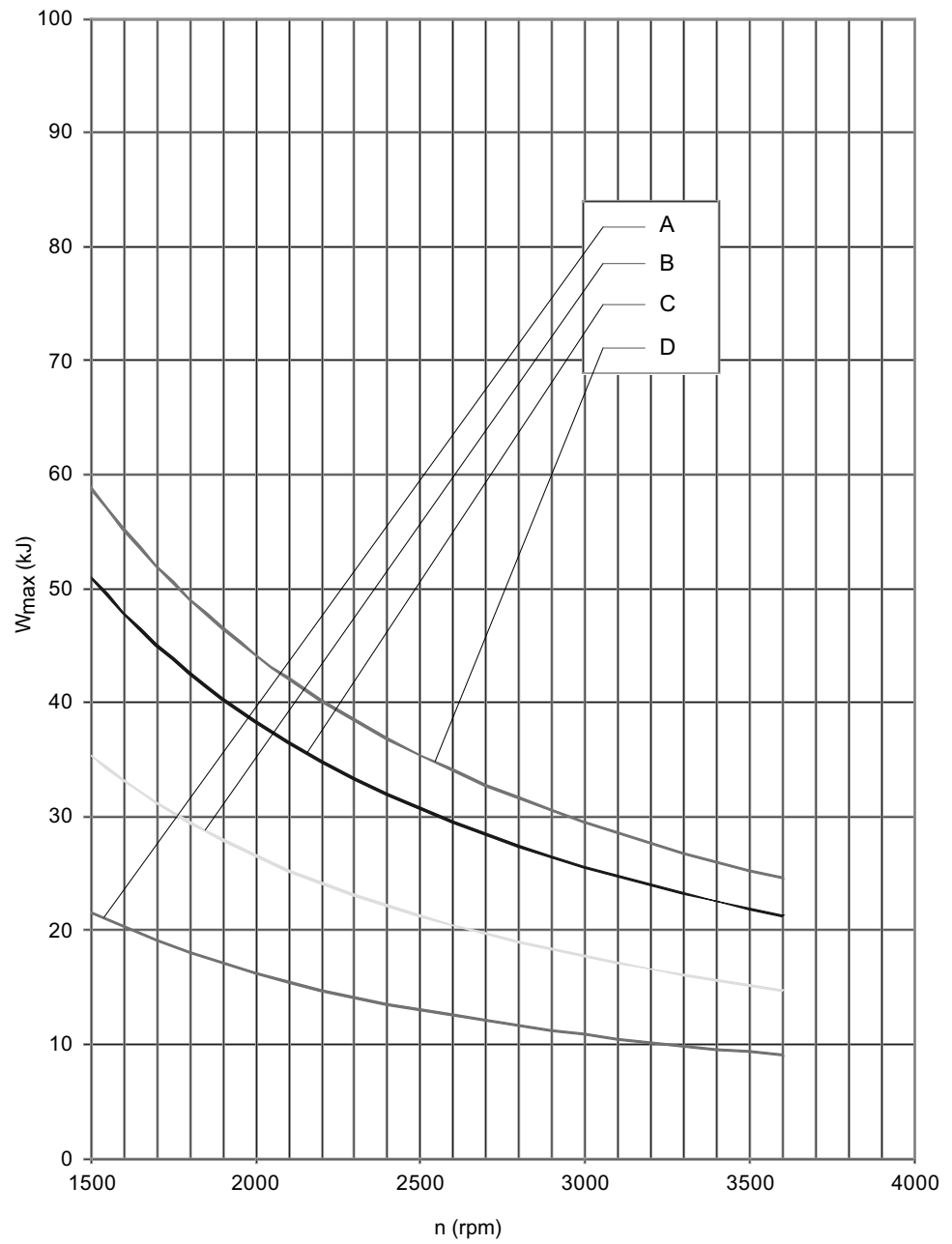

9007208523591563

BE20 brakeValue table W_{\max} BE20:

n in rpm	Limit curve A	Limit curve B	Limit curve C	Limit curve D
	BE20 ($f_v = 1 / f_M = 1$)	BE20 ($f_v = 10 / f_M = 0.8$)	BE20 ($f_v = 50 / f_M = 0.7$)	BE20 ($f_v = 100 / f_M = 0.6$)
1000	47	77	112	129
1100	43	70	102	117
1200	39	65	93	108
1300	36	60	86	99
1400	34	55	80	92
1500	32	52	75	86
1600	30	48	70	81
1700	28	46	66	76
1800	26	43	62	72
1900	25	41	59	68
2000	24	39	56	65
2100	23	37	53	61
2200	22	35	51	59
2300	21	34	49	56
2400	20	32	47	54
2500	19	31	45	52
2600	18	30	43	50
2700	18	29	41	48
2800	17	28	40	46
2900	16	27	39	45
3000	16	26	37	43
3100	15	25	36	42
3200	15	24	35	40
3300	14	23	34	39
3400	14	23	33	38
3500	14	22	32	37
3600	13	22	31	36

Diagram W_{max} BE20:

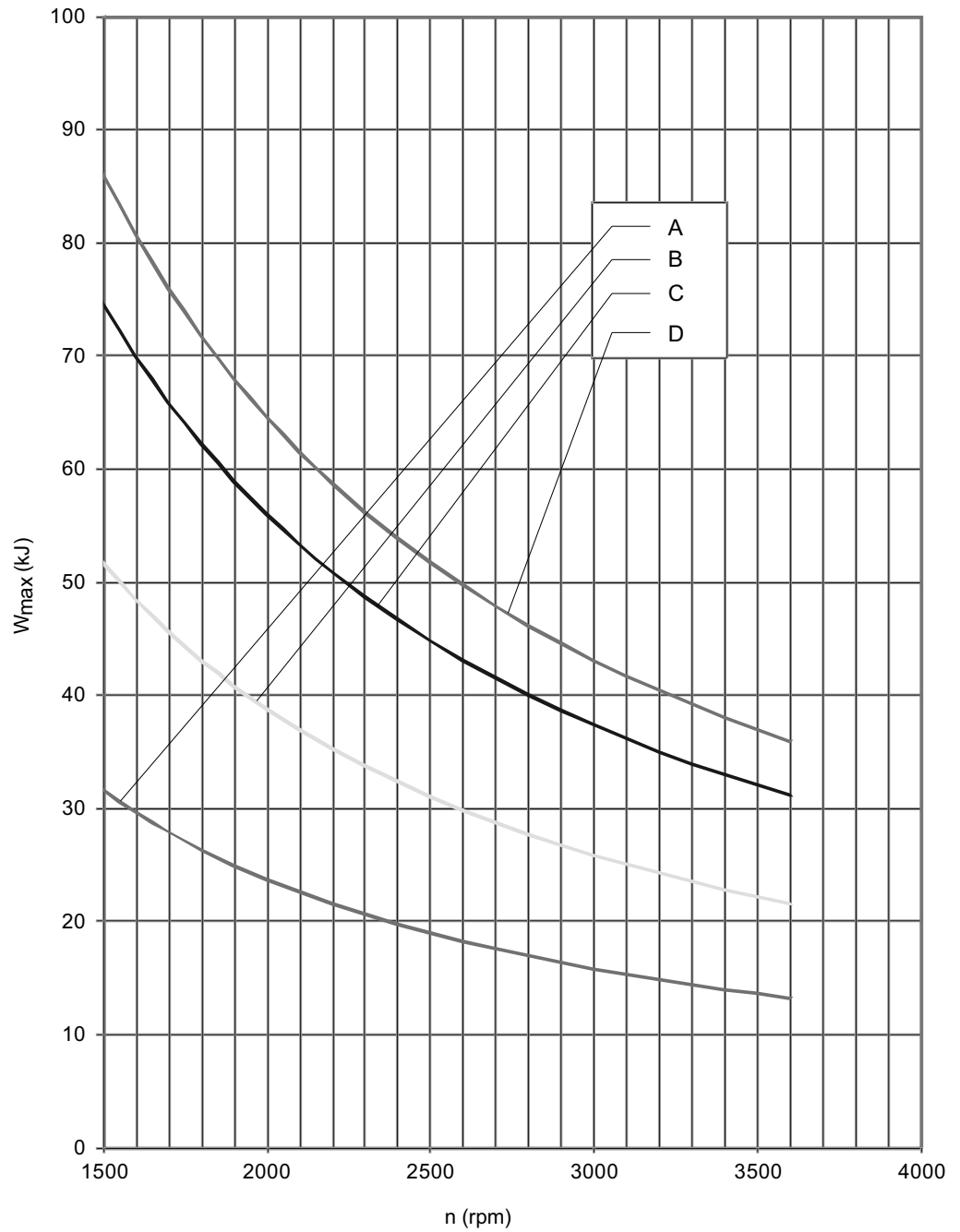

9007208523593483

BE30 brakeValue table W_{max} BE30:

n in rpm	Limit curve A	Limit curve B	Limit curve C	Limit curve D
	BE30 ($f_v = 1 / f_M = 1$)	BE30 ($f_v = 10 / f_M = 0.8$)	BE30 ($f_v = 50 / f_M = 0.7$)	BE30 ($f_v = 100 / f_M = 0.6$)
1000	56	92	131	153
1100	51	83	119	139
1200	46	76	109	127
1300	43	70	101	117
1400	40	65	93	109
1500	37	61	87	102
1600	35	57	82	95
1700	33	54	77	90
1800	31	51	73	85
1900	29	48	69	80
2000	28	46	65	76
2100	27	44	62	73
2200	25	42	59	69
2300	24	40	57	66
2400	23	38	54	64
2500	22	37	52	61
2600	21	35	50	59
2700	21	34	48	56
2800	20	33	47	54
2900	19	32	45	53
3000	19	31	44	51
3100	18	30	42	49
3200	17	29	41	48
3300	17	28	40	46
3400	16	27	38	45
3500	16	26	37	44
3600	15	25	36	42

Diagram W_{max} BE30:

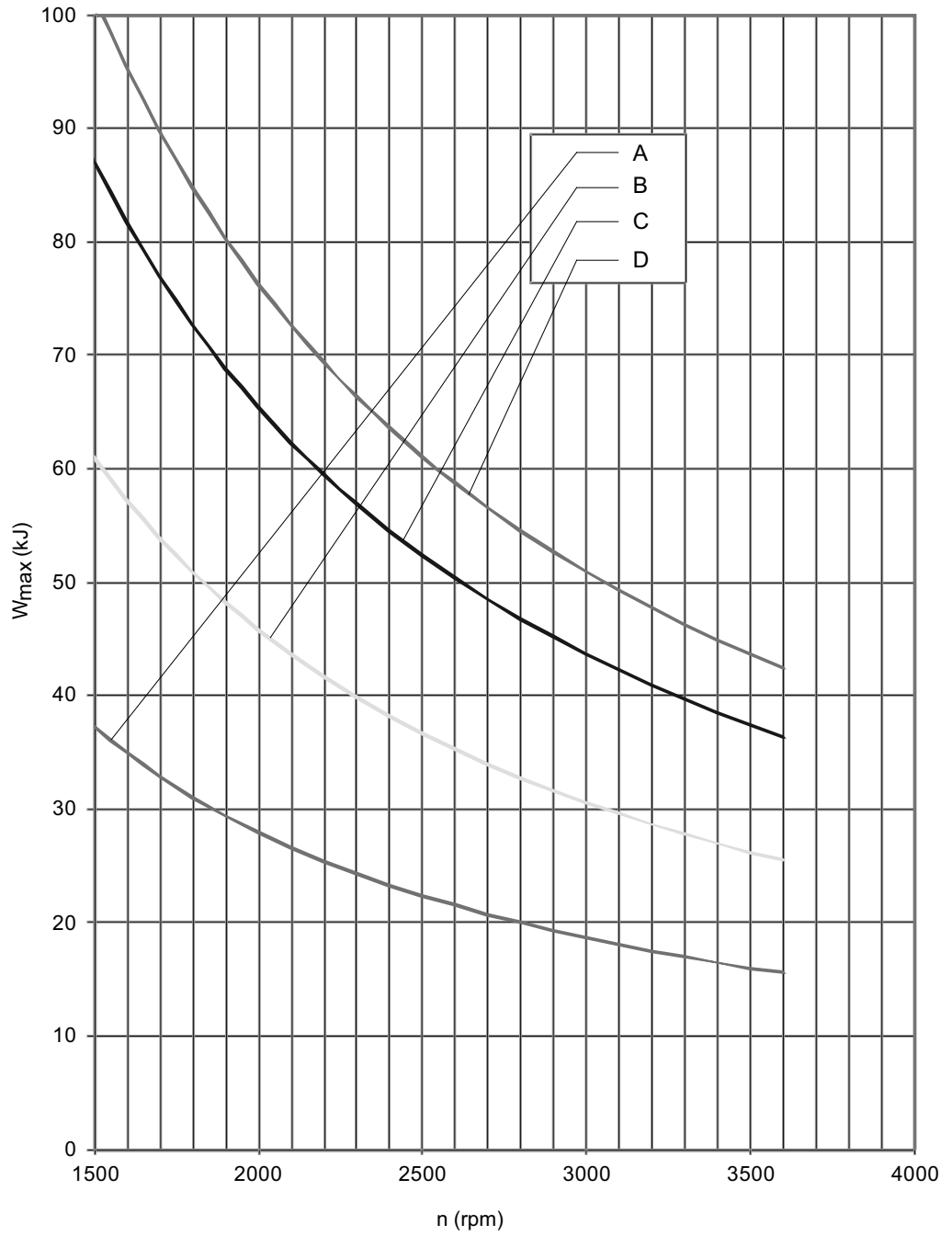

9007208523595403

BE32 brakeValue table W_{max} BE32:

n in rpm	Limit curve A	Limit curve B	Limit curve C	Limit curve D
	BE32 ($f_v = 1 / f_M = 1$)	BE32 ($f_v = 10 / f_M = 0.8$)	BE32 ($f_v = 50 / f_M = 0.7$)	BE32 ($f_v = 100 / f_M = 0.6$)
1000	96	157	224	261
1100	87	143	204	238
1200	80	131	187	218
1300	74	121	172	201
1400	68	112	160	187
1500	64	105	149	174
1600	60	98	140	163
1700	56	92	132	154
1800	53	87	124	145
1900	50	83	118	138
2000	48	78	112	131
2100	46	75	107	125
2200	44	71	102	119
2300	42	68	97	114
2400	40	65	93	109
2500	38	63	90	105
2600	37	60	86	101
2700	36	58	83	97
2800	34	56	80	93
2900	33	54	77	90
3000	32	52	75	87
3100	31	51	72	84
3200	30	49	70	82
3300	29	48	68	79
3400	28	46	66	77
3500	27	45	64	75
3600	27	44	62	73

Diagram W_{max} BE32:

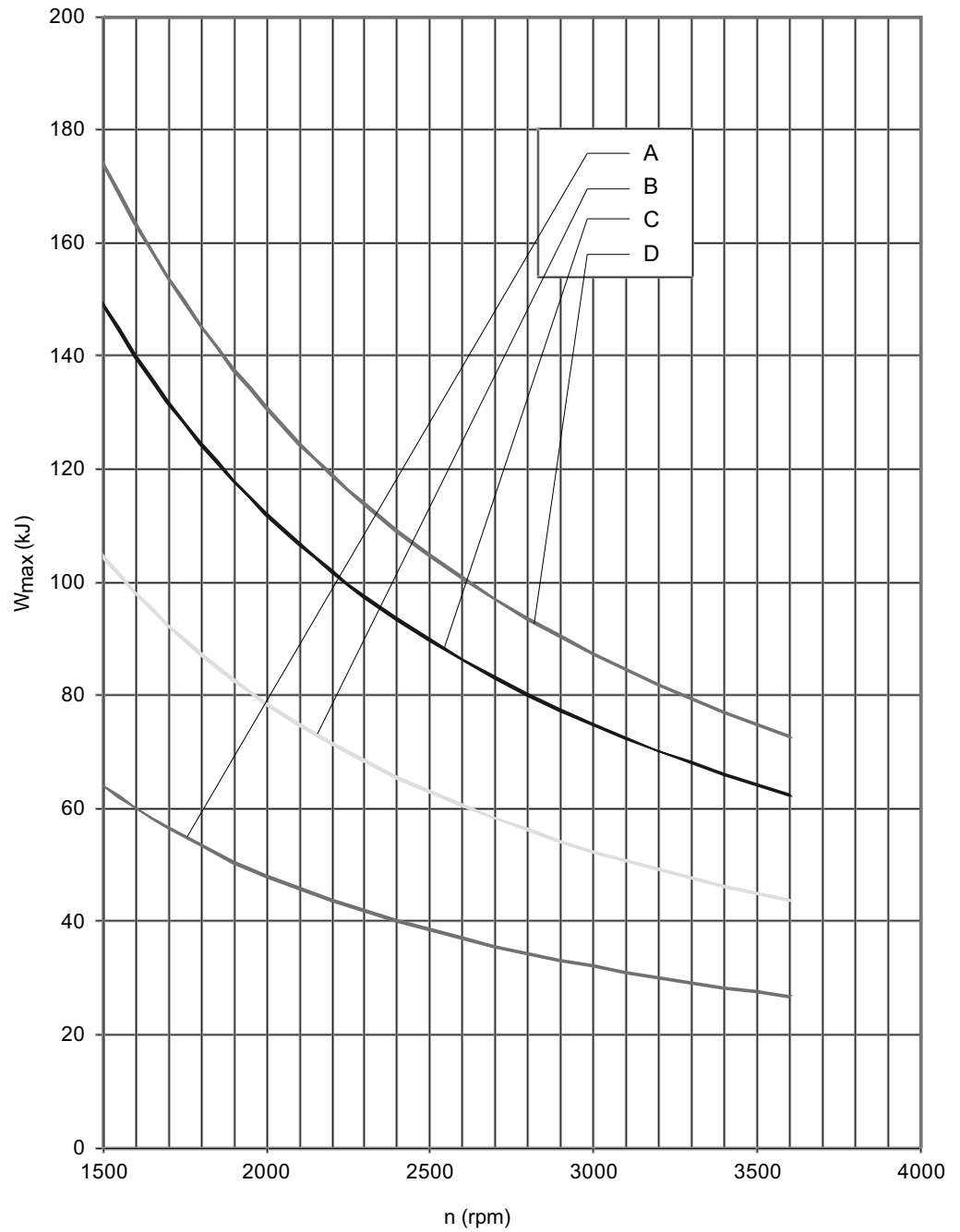

9007208523597323

19290411/EN – 10/2014

8.12 BST safety-related brake control

8.12.1 Description

The safety-related BST brake module is responsible for the power supply and control of the SEW disk brakes. The design is based on the regulations contained in EN 13849-1.

The following safety functions can be realized using the safety-related brake module:

- SBC (safe brake control according to EN ISO 61800-5-2)

8.12.2 Performance level

The safety-related BST brake module was developed and tested according to the following safety requirements:

- Performance level d according to EN ISO 13849-1

8.12.3 Safety concept

- The safety-related BST brake module features the following connection options:
 - an external, fail-safe safety relay
 - or
 - an external fail-safe safety controller.
- Disconnecting the safe control voltage $V_{24\text{ V safe}}$ means the connected brake is disconnected from the power supply. The power supply required for releasing the brake is interrupted safely.
- Instead of separating the brake control galvanically from the power supply using contactors or switches, the safe disconnection safely prevents the power semiconductors in the safety-related BST brake module from being activated. This means that all connected brakes are de-energized although the supply voltage is still present at the safety-related BST brake module.

8.12.4 BST break module block diagram

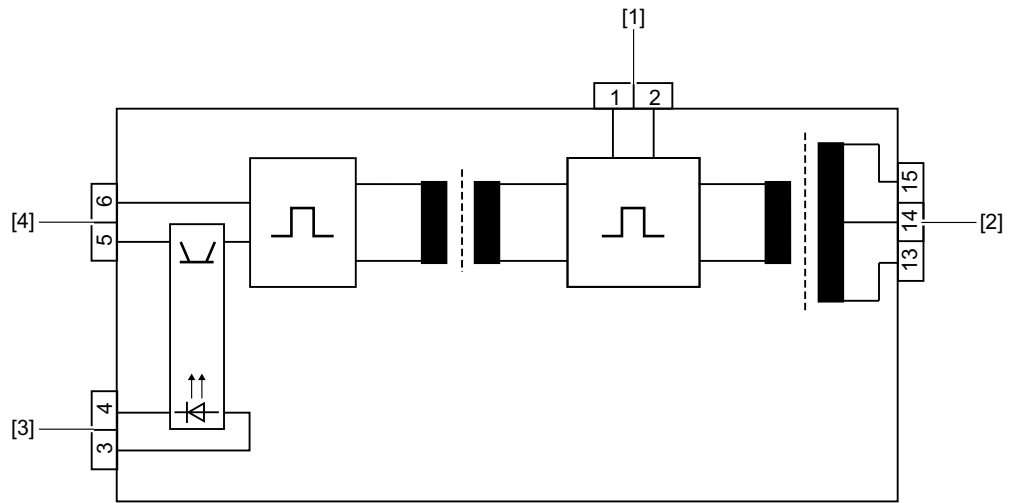

9007201124185483

- [1] DC link voltage V_{DC} (terminal 1/2) input
- [2] Brake (terminal 13/14/15) output
- [3] Functional control voltage $V_{24V in}$ (terminal 3/4) input
- [4] Safety-related control voltage $V_{24V safe}$ (terminal 5/6) input

8.12.5 BST brake module - technical data

The following table lists the technical data of the BST brake modules for installation in the control cabinet and the assignments with regard to motor size and connection technology.

Type	Function	Voltage	Holding current	Type designation	Part number
BST	Safety-related brake module	AC 230 V	DC 1.2 A	BST 1.2S	13001337
		AC 400 V	DC 0.7 A	BST 0.7S	13000772
		AC 460 V	DC 0.6 A	BST 0.6S	08299714

Type	Type designation	Standard connection box	IS /plug connector	IV /plug connector (/AC..., /AS..., /AM..., /AB..., /AD..., /AK...)
BST	BST 1.2S	DR.71 – 225	DR.71 – 132	DR.71 – 225
		BE05 – BE32	BE05 – BE11	BE05 – BE32
	BST 1.0S	DR.71 – 225	DR.71 – 132	DR.71 – 225
BST 0.7S	BST 0.7S	DR.71 – 225	DR.71 – 132	DR.71 – 225
		BE05 – BE32	BE05 – BE11	BE05 – BE32

Information on design

The BST brake module is used within the application with a standard brake or a safety-related brake.

19290411/EN – 10/2014

Dimension drawing

The following dimension drawing shows the space required in the control cabinet.

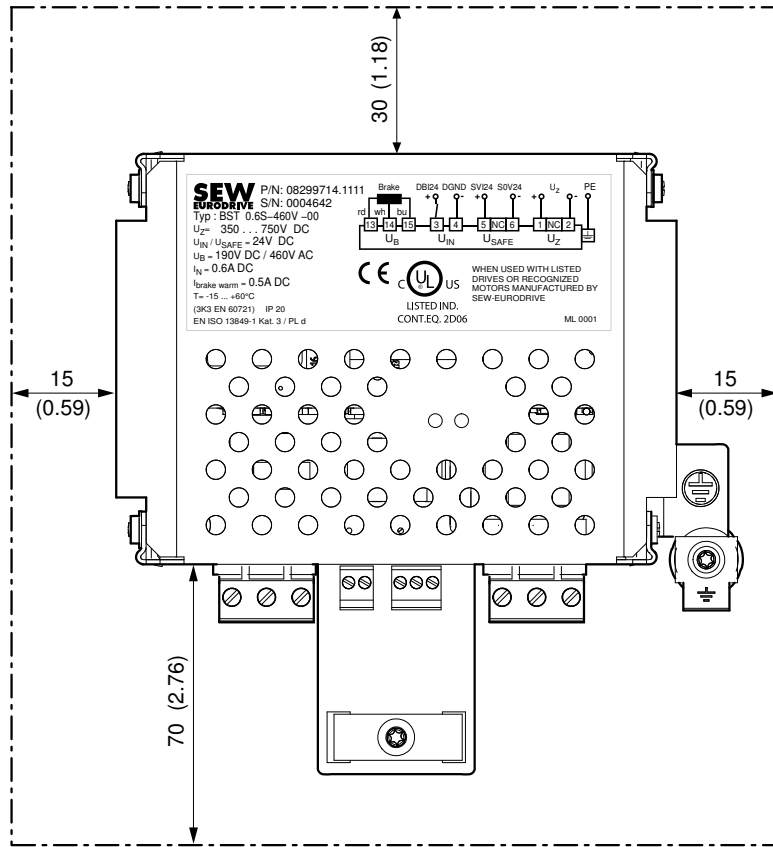

27021597901311499