

Features

- 1-channel isolated barrier
- 24 V DC supply (Power Rail)
- Dry contact or NAMUR inputs
- Input frequency 1 mHz ... 5 kHz
- 2 relay contact outputs
- Start-up override
- Configurable by keypad
- Line fault detection (LFD)
- Up to SIL2 acc. to IEC 61508

Function

This isolated barrier is used for intrinsic safety applications. It monitors for an overspeed or underspeed condition of a digital signal (NAMUR sensor/mechanical contact) from a hazardous area by comparing the input frequency to the user programmed reference frequency.

An overspeed or underspeed condition is signaled via the relay outputs. Line fault detection of the field circuit is indicated by a red LED, Power Rail and relay. The start-up override feature sets relay outputs to default conditions programmed by the user for up to 1,000 seconds.

The unit is easily programmed by the use of a keypad located on the front of the unit.

A unique collective error messaging feature is available when used with the Power Rail system.

For additional information, refer to the manual and www.pepperl-fuchs.com.

Assembly

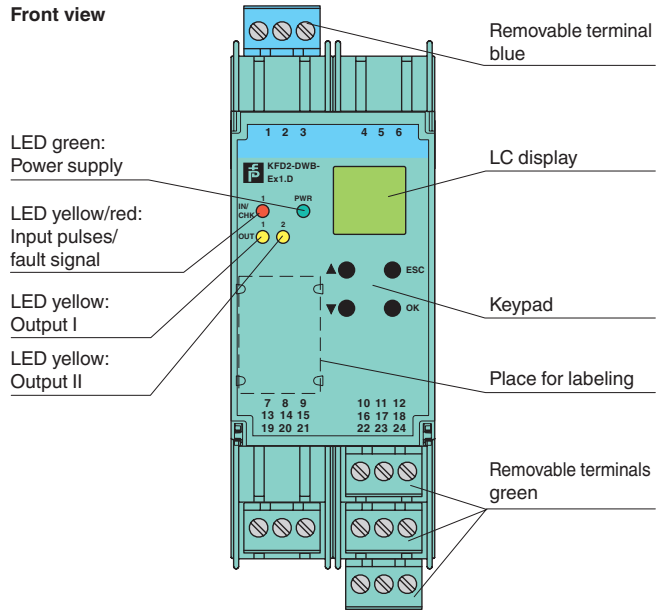

SIL2

Connection

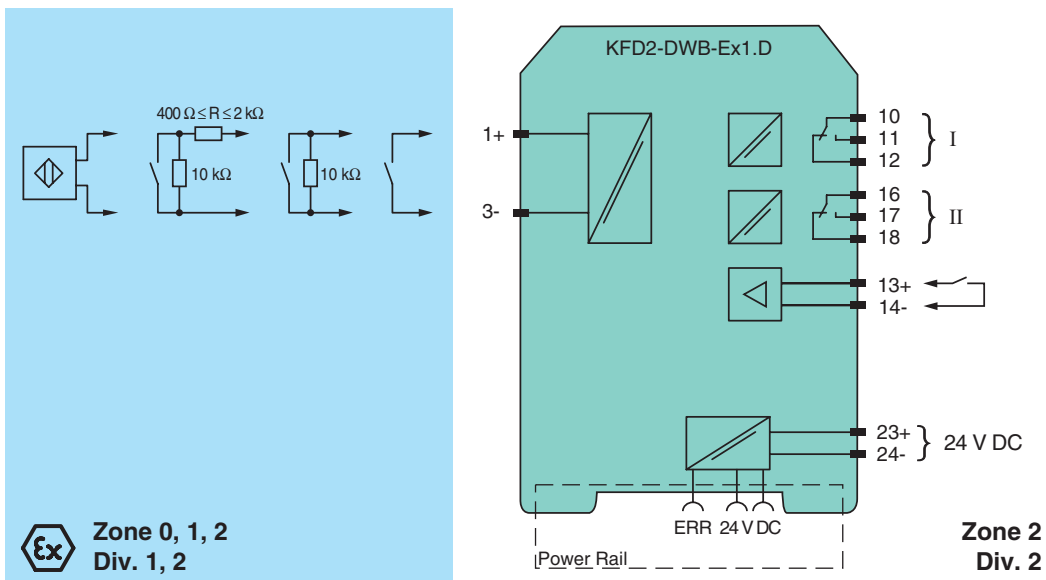

Release date 2011-09-28 11:51 Date of issue 2011-09-28 231203_eng.xml

General specifications		
Signal type	Digital Input	
Supply		
Connection	terminals 23+, 24- or power feed module/Power Rail	
Rated voltage	20 ... 30 V DC	
Rated current	approx. 100 mA	
Power loss/power consumption	≤ 1.8 W / 1.8 W	
Input		
Connection	Input I: intrinsically safe: terminals 1+, 3- Input II: non-intrinsically safe: terminals 13+, 14-	
Input I	acc. to EN 60947-5-6 (NAMUR), see system description for electrical data	
Pulse duration	> 50 μs	
Input frequency	0.001 ... 5000 Hz	
Lead monitoring	breakage I ≤ 0.15 mA; short-circuit I > 6.5 mA	
Input II	startup override: 1 ... 1000 s, adjustable in steps of 1 s	
Active/Passive	I > 4 mA (for min. 100 ms) / I < 1.5 mA	
Open circuit voltage/short-circuit current	18 V / 5 mA	
Output		
Connection	output I: terminals 10, 11, 12 output II: terminals 16, 17, 18	
Collective error message	Power Rail	
Output I, II	signal, relay	
Contact loading	250 V AC / 2 A / cos φ ≥ 0.7; 40 V DC / 2 A	
Mechanical life	5 x 10 ⁷ switching cycles	
Energized/De-energized delay	approx. 20 ms / approx. 20 ms	
Transfer characteristics		
Input I		
Measurement range	0.001 ... 5000 Hz	
Resolution	0.1 % of measured value , ≥ 0.001 Hz	
Accuracy	0.1 % of measured value , > 0.001 Hz	
Measuring time	< 100 ms	
Influence of ambient temperature	0.003 %/K (30 ppm)	
Output I, II		
Response delay	≤ 200 ms	
Electrical isolation		
Output I, II against each other	reinforced insulation according to IEC 61140, rated insulation voltage 300 V _{eff}	
Output I, II/other circuits	reinforced insulation according to IEC 61140, rated insulation voltage 300 V _{eff}	
Start-up override/power supply and collective error	functional insulation acc. to IEC 62103, rated insulation voltage 50 V _{eff}	
Directive conformity		
Electromagnetic compatibility		
Directive 2004/108/EC	EN 61326-1:2006	
Low voltage		
Directive 2006/95/EC	EN 50178:1997	
Conformity		
Insulation coordination	IEC 62103	
Electrical isolation	IEC 62103	
Electromagnetic compatibility	NE 21	
Protection degree	IEC 60529	
Protection against electric shock	IEC 61140	
Ambient conditions		
Ambient temperature	-20 ... 60 °C (-4 ... 140 °F)	
Mechanical specifications		
Protection degree	IP20	
Mass	300 g	
Dimensions	40 x 119 x 115 mm (1.6 x 4.7 x 4.5 in) , housing type C3	
Data for application in connection with Ex-areas		
EC-Type Examination Certificate	TÜV 99 ATEX 1408 , for additional certificates see www.pepperl-fuchs.com	
Group, category, type of protection	⊕ II (1)GD, I (M1) [Ex ia] IIC, [Ex iaD], [Ex ia] I (-20 °C ≤ T _{amb} ≤ 60 °C)	
Supply		
Maximum safe voltage U _m	40 V DC (Attention! U _m is no rated voltage.)	
Input I		
Voltage U _o	10.1 V	

Release date 2011-09-28 11:51 Date of issue 2011-09-28 231203_eng.xml

Current	I_o	13.5 mA
Power	P_o	34 mW (linear characteristic)
Input II		terminals 13+, 14- non-intrinsically safe
Maximum safe voltage	U_m	40 V (Attention! The rated voltage can be lower.)
Output I, II		terminals 10, 11, 12; 16, 17, 18 non-intrinsically safe
Maximum safe voltage	U_m	253 V (Attention! The rated voltage can be lower.)
Contact loading		253 V AC/2 A/cos $\phi > 0.7$; 40 V DC/2 A resistive load (TÜV 99 ATEX 1471)
Statement of conformity		TÜV 02 ATEX 1885 X , observe statement of conformity
Group, category, type of protection, temperature class		 II 3G Ex nA nC IIC T4
Output I, II		
Contact loading		50 V AC/2 A/cos $\phi > 0.7$; 40 V DC/1 A resistive load
Electrical isolation		
Input I/other circuits		safe electrical isolation acc. to IEC/EN 60079-11, voltage peak value 375 V
Directive conformity		
Directive 94/9/EC		EN 60079-0:2006, EN 60079-11:2007, EN 60079-15:2005, EN 60079-26:2007, EN 61241-0:2006, EN 61241-11:2006
International approvals		
FM approval		
Control drawing		16-538FM-12
General information		
Supplementary information		EC-Type Examination Certificate, Statement of Conformity, Declaration of Conformity, Attestation of Conformity and instructions have to be observed where applicable. For information see www.pepperl-fuchs.com .

Accessories

Power feed module KFD2-EB2

The power feed module is used to supply the devices with 24 V DC via the Power Rail. The fuse-protected power feed module can supply up to 100 individual devices depending on the power consumption of the devices. A galvanically isolated mechanical contact uses the Power Rail to transmit collective error messages.

Power Rail UPR-03

The Power Rail UPR-03 is a complete unit consisting of the electrical inset and an aluminium profile rail 35 mm x 15 mm. To make electrical contact, the devices are simply engaged.

Profile Rail K-DUCT with Power Rail

The profile rail K-DUCT is an aluminum profile rail with Power Rail insert and two integral cable ducts for system and field cables. Due to this assembly no additional cable guides are necessary.



Attention

Power Rail and Profile Rail must not be fed via the device terminals of the individual devices!