

# CP25QXVT80 CP70QXVT80 OCP662X0080

High-Performance Distance Sensor



## Operating Instructions

## Table of contents

<b>1. Proper Use</b>	<b>3</b>
<b>2. Safety Precautions</b>	<b>3</b>
2.1. Safety Precautions	3
2.2. Laser/LED warning	3
2.3. Approvals and IP Protection	4
<b>3. Technical Data</b>	<b>5</b>
<b>4. Installation Instructions</b>	<b>7</b>
<b>5. Initial Operation</b>	<b>8</b>
<b>6. Function</b>	<b>8</b>
<b>7. Manual Settings</b>	<b>9</b>
<b>8. Maintenance Instructions</b>	<b>18</b>
<b>9. Proper Disposal</b>	<b>18</b>
<b>10. EU Declaration of Conformity</b>	<b>19</b>

## 1. Proper Use

This wenglor product has to be used according to the following functional principle:

These sensors work with a high-resolution CMOS line and DSP technology and determine distance using angular measurement. As a result, material, color and brightness related switching point differences are virtually eliminated. Two independent switching outputs are available, at which two switching thresholds and one on or off-delay time (in 10 ms steps) can be configured. Sensor functions can be activated, and scanning results can be acquired via the RS-232 interface.

## 2. Safety Precautions

### 2.1. Safety Precautions

- This operating instruction is part of the product and must be kept during its entire service life.
- Read this operating instruction carefully before using the product.
- Installation, start-up and maintenance of this product has only to be carried out by trained personnel.
- Tampering with or modifying the product is not permissible.
- Protect the product against contamination during start-up.
- Not a safety component in accordance with the EU Machinery Directive.

### 2.2. Laser/LED warning

For the respective Laser/LED Class please view the technical data of the product.



#### Class Laser 1 (EN 60825-1)

Observe all applicable standards and safety precautions.

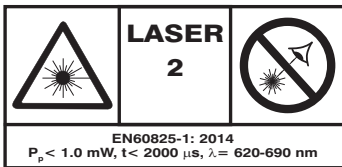

#### Class Laser 2 (EN 60825-1)

Observe all applicable standards and safety precautions.

The enclosed laser warning labels must be attached and visible at all time. Do not stare into beam.

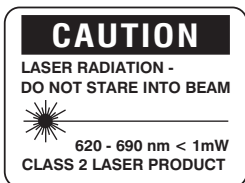

#### CAUTION!

Observe all applicable standards and safety precautions. The enclosed laser warning labels must be attached and visible at all time. Do not stare into beam.

# EN

## 2.3. Approvals and IP Protection



**RoHS**

### 3. Technical Data

Optical Data	CP70QXVT80	CP25QXVT80	OCP662X0080
Range	660 mm	240 mm	660 mm
Adjustable Range	60...660 mm	40...240 mm	60...660 mm
Switching Hysteresis*	<1 %	<0,5 %	<1 %
Light Source	Laser (red)	Laser (red)	Laser (red)
Wave Length	655 nm	655 nm	655 nm
Service Life (Tu = 25 °C)	100000 h	100000 h	100000 h
Laser Class (EN 60825-1)	2	2	1
max. Ambient Light	10000 Lux	10000 Lux	10000 Lux
Light Spot dimension 60 mm	0,6 × 2,5 mm	0,6 × 2,5 mm	0,5 × 1,2 mm
Light Spot dimension 660 mm	3,0 × 8,0 mm	1,0 × 4,0 mm	2,0 × 5,5 mm

Electrical Data			
Power Supply	10...30 V DC	10...30 V DC	10...30 V DC
Power Consumption (Ub=24 V)	<50 mA	<50 mA	<50 mA
Switching Frequency	250 Hz	500 Hz	100 Hz
Response Time	< 2 ms	< 1 ms	< 5 ms
ON-/OFF-Delay	0...1 s	0...1 s	0...1 s
Temperature Drift	<50 µm/°C	<15 µm/°C	<50 µm/°C
Temperature Range	-25...60 °C	-25...60 °C	-25...60 °C
Switching Outputs	2	2	2
Switching Output Voltage Drop	<1,5 V	<1,5 V	<1,5 V
Switching Output/Switching Current	200 mA	200 mA	200 mA
Error Outputs	1	1	1
Short Circuit Protection	yes	yes	yes
Reverse Polarity Protection	yes	yes	yes
Teach Mode	HT, VT, TP	HT, VT, TP	HT, VT, TP
Interface	RS-232	RS-232	RS-232
Baud Rate	38400 Bd	38400 Bd	38400 Bd
Protocol	8 N 1	8 N 1	8 N 1
NO/NC switchable	yes	yes	yes
PNP/NPN/Push-Pull programmable	yes	yes	yes

Mechanical Data			
Adjustment	Teach-In	Teach-In	Teach-In
Housing	Plastic	Plastic	Plastic
Protection Mode	IP67	IP67	IP67
Connection	M 12 × 1	M 12 × 1	M 12 × 1
Protection Class	III	III	III
FDA Accession Number	0820587-000	0820586-000	1120728-000

Reference material: kodak white 90 % remission

\*Relating to the adjusted switching distance

HT: Background Teach-In, VT: Foreground teach-In, TP: Key Potentiometer

## Connection Diagram

737

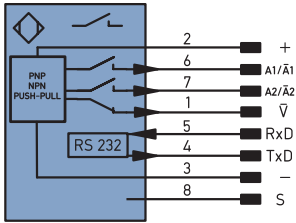

+	10 to 30 V supply power
A1/ $\bar{A}1$	Switching output A1
A2/ $\bar{A}2$	Switching output A2
V	Error Output
RxD	Interface input lead
TxD	Interface output lead
-	Minus
S	Shield

## Housing Dimensions

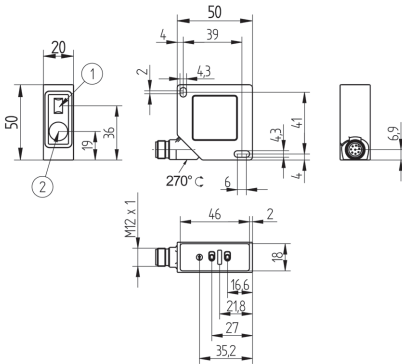

① Transmitter Diode

② Receiver Diode

Screw M4 = 0,5 Nm

## Control Panel

On the control panel you find the Plus key and the Minus key, several LEDs and the Rotary selector switch. The Rotary selector switch is used for choosing the setting- and operation functions.

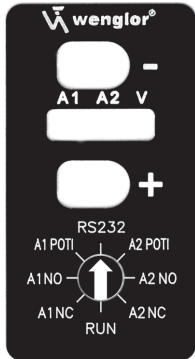

⊖ = Minus key (with LED)

⊕ = Plus key (with LED)

A1; A2; V = LEDs for Output A1, Output A2 and Error output

A2NC = Teach-In Switching Point Output A2, Normally Open function

RUN = Normal Mode

A1NC = Teach-In Switching Point Output A1, Normally Closed function

A1NO = Teach-In Switching Point Output A1, Normally Open function

A1POTI = Teach-In Switching Point with Key Potentiometer for Output A1

RS232 = Normal Mode (identical to RUN)

A2POTI = Teach-In Switching Point with Key Potentiometer for Output A2

ⓘ = Rotary selector switch

## Complementary Products (see catalog)

wenglor offers Connection Technology for field wiring.

Suiting Mounting Technology No.

380

Suiting Connection Technology No.

80

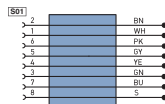

Interface Cable S232W3

Protection Housing Set ZSP-NN-02

Protection Housing ZSV-0x-01

## 4. Installation Instructions

During use of the sensors, applicable electrical and mechanical regulations, standards and safety precautions must be adhered to. The sensor must be protected against mechanical influences.

In case of very glossy surfaces the sensor has to be mounted slightly inclined (approx. 5°), to inhibit a direct reflection of the laser beam into the optics. The sensor has ideal ambient light properties if the background is located within the working range.

## 5. Initial Operation

Please control the proper connection of all conductors.

Impress a supply voltage of 10...30 V DC.

The LEDs A1 resp. A2 will now light up, if an object reaches the respective switching distance.

The settings can be operated either with the RS-232 interface or manually.

## 6. Function

The sensor uses a high-resolution CMOS line array, virtually eliminating material, color and brightness related switching point differences. Two independent switching outputs are available, at which two switching thresholds and one on or off-delay time (in 10 ms steps) can be configured. Sensor functions can be activated, and scanning results can be acquired via the RS-232 interface.

### Outputs:

**The outputs can be operated as PNP, NPN or Push-Pull. The chosen setting applies for all outputs.**

#### Output A1, Output A2:

These outputs are independent working switching outputs, at which two switching thresholds and on- or off-delay time (in 10 ms steps) can be configured. The outputs can be operated in Normally Open or Normally Closed function. The switching points are adjustable with the teaching mode or the key potentiometer.

#### Error output:

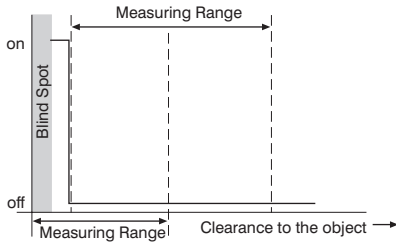

This output works as Normally Closed and is independent from the chosen delay times at outputs A1 and A2. Error messages are indicated at the Error output LED V, e. g. in case of not measurable surfaces or contamination.

#### RS-232 interface



This sensor is equipped with an RS-232 interface for communication with a device such as PC or a controller. Sensor functions can be activated, and scanning results can be acquired via the RS-232 interface.











## 7. Manual Settings

This wenglor® sensor is equipped with programmable output stages. Either PNP, NPN or Push-Pull can be selected. At the delivery status, PNP-stage is set. By the position of the rotary selector switch **A1NC**, **A1NO**, **A2NC** or **A2NO** you define, if the respective output operates as Normally Open or Normally Closed after the teaching process.





### 1) Select the output mode for the outputs:

Set the rotary selector switch  to **A1POTI**. Press and hold the plus  and minus  keys simultaneously for 5 seconds until the red error output-LED V blinks, then release the keys.

- To set up the output mode **PNP**, press the plus key  briefly
  - plus key  LED lights up
  - from now on the outputs operate as PNP\*
- To set up the output mode **NPN**, press the minus key  briefly
  - minus  key LED lights up
  - from now on the outputs operate as NPN
- To set up the output mode **Push-Pull**, briefly press the minus- and plus key simultaneously  
  - minus key LED  and plus key LED  light up
  - from now on the outputs operate as Push-Pull
- Rotary selector switch  to **RUN** or **RS-232**

### 2) Select Normally Closed or Normally Open-function for the respective output:



Firstly set the rotary selector switch  for output A1 to the desired function and continue with point 3) or 4) to set up the switching distance for output A1. Afterwards proceed likewise for output A2.

- output A1/Normally Closed NC: set rotary selector switch  to **A1NC** and press any key
- output A1/Normally Open NO: set rotary selector switch  to **A1NO** and press any key\*
- output A2/Normally Closed NC: set rotary selector switch  to **A2NC** and press any key
- output A2/Normally Open NO: set rotary selector switch  to **A2NO** and press any key\*

\* Default Setting

### 3) Set the Switching Distance for the respective output with Teach-In:

#### Foreground Teach-In: VT

- level the light spot at the foreground (e.g. can end)
- press the plus key  briefly
  - the teach mode VT is indicated by the plus key LED , which lights up
- rotary selector switch  to **RUN** or **RS-232**

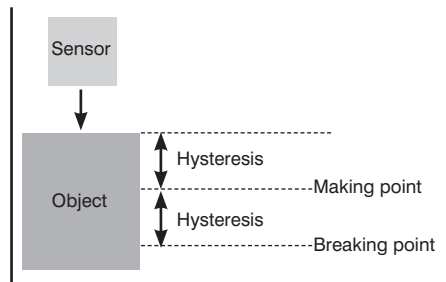

## Background Teach-In: HT

- level the light spot at the background (e. g. conveyor belt)
- press the minus key **⊖** briefly
  - The teach mode HT is indicated by the minus key LED **⊖**, which lights up
- rotary selector switch **⌚** to **RUN** or **RS-232**

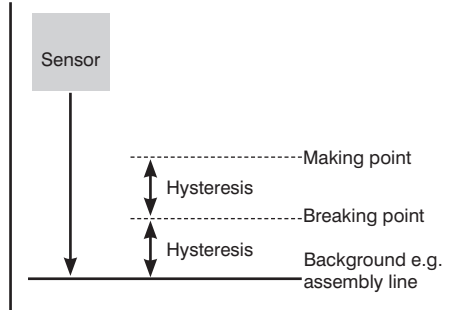

## 4) Set the Switching Distance for the respective output with the key potentiometer:

- Adjustment of the switching point for output A1: rotary selector switch **⌚** to A1POT1
- Adjustment of the switching point for output A2: rotary selector switch **⌚** to A2POT1
  - to increase the switching point distance at the respective output, press the plus key **⊕**.
  - to reduce the switching point distance at the respective output, press the minus key **⊖**.

To trim the switching point, e.g. after a teach-in operation, press the keys briefly for several times.

With a longer pressure on the keys you can move the switching point over the whole working range.

→ The position of the adjusted switching distance is indicated through a light scale of the plus- and minus-key LEDs **⊕** **⊖**. If the minimal possible switching distance is reached, the minus key LED **⊖** blinks. If the maximal possible switching distance is reached, the plus key LED **⊕** blinks.

- rotary selector switch **⌚** to **RUN** or **RS-232**

## 5) Execute Sensor Reset:

The reset sets the switching points back to delivery status and deactivates time delays, filter functions or extra hysteresis.

- rotary selector switch **⌚** to A2POT1
- press plus key **⊕** and minus key **⊖** simultaneously for 5 seconds until the red error output LED **V** blinks
- rotary selector switch **⌚** to **RUN** or **RS-232**

## Settings and Queries via the RS-232 interface

The interface utilizes a software handshake procedure (see protocol specification below). All sensor settings can be selected digitally with a PC, and all values generated by the sensor can be read out at a PC. The RS-232 interface connections RxD (5, grey) and TxD (connection 4, yellow) correspond to minus (connection 3, green) and can be connected to the appropriate connections of the communication partner.

The configuration can be made either with the following commands or easily by means of a software.

## Software Tools

Software for the interface for download under: [www.wenglor.com](http://www.wenglor.com)

## Interface configuration

Baud rate (Delivery status): 38.400 baud (adjustable, view page 16)

8 data bits, no parity, 1 stop bit

### Plug connectors of the wenglor® Plug Adapter S232W3:

- 8-pin M12 plug connector for connecting the power supply and the outputs
- 8-pin M12 socket connector for direct sensor connection
- 9-pin M12 sub-miniature socket connector for direct connection to the RS-232 interface at the PC, or the utilized controller

### 1) Connect the sensor over the wenglor® Plug Adapter S232W3 with PC, controller etc.

Installing the wenglor® Plug Adapter S232W3:

- Set the rotary selector switch  to **RUN** or **RS-232**
- Disconnect the 8-conductor connector cable (S80-xx) from the sensor
- Connect the S232W3 plug adapter directly to the sensor
- Connect the 8-conductor connector cable (S80-xx) to the plug adapter
- Connect the 9-pin sub-miniature socket connector to the serial interface at the PC
- Switch the power supply on

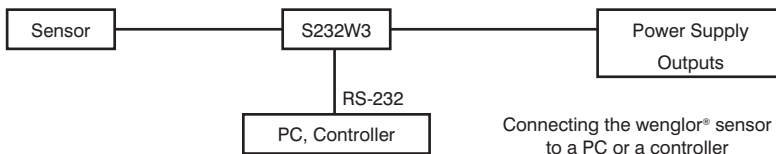

### 2) Procedure of the interface operation:

- Set the rotary selector switch  to **RUN** or **RS-232**
- Utilize our user-software to enter or query the sensor settings or enter the interface commands according to the protocol. Every interface command and every answer of the sensor starts with "/" (ASCII 47) and ends with "." (ASCII 46). In case of an incorrect communication, the sensor emits a Negative Acknowledge character (ASCII 21). If a command is not closed with ".", the sensor remains in wait state and does not give an answer or error message.
- Even with continuous query it should be adhered to a pause of 10 ms between two interface commands.

## Protocol for Communications via the RS-232 Interface

### Frame Layout for Data Transmission

Transmitting Partner	Characters (ASCII)		Receiving Partner	Frame Segment
Start Character	/ (ASCII 47)	→	Connect	Frame header
Length information	2 Byte	→	Connect	Frame header
Command Bytes	2 Byte	→		Frame header
1. Data Byte	2 Byte	→	Data information	User data
2. Data Byte	2 Byte	→		User data
..	..	→	Data information	User data
n. Data Byte	..	→	Data information	User data
Checksum (BCC)	2 Byte	→		Frame end
Stop bit	. (ASCII 46)	→	Disconnected	Frame end

Calculating the Checksum BCC (Block Check Character): The Checksum is generated from an EXOR frame operation.

Start Character	Length	Command	Data	Checksum	Stop Character
/	02	0D	00	59	.
2FH	30H 32H	30H 44H	30H 30H	35H 39H	2EH

Data used to calculate the checksum

#### Calculating Example:

/	2FH	=	0010 1111
0	30H	=	0011 0000
<hr/>			
2	XOR	=	0001 1111
	32H	=	0011 0010
<hr/>			
0	XOR	=	0010 1101
	30H	=	0011 0000
<hr/>			
D	XOR	=	0001 1101
	44H	=	0100 0100
<hr/>			
0	XOR	=	0101 1001
	30H	=	0011 0000
<hr/>			
0	XOR	=	0110 1001
	30H	=	0011 0000
<hr/>			
	XOR	=	0101 1001

#### Program Example:

Start
Transmitting Frame = "/020D0059." (Example) Transmitting Frame Length = 10 (in this example);
checksum = 0; n = 1;
as long as: n < (Transmitting Frame Length - 3)
Checksum = Checksum EXOR Transmitting Frame character (n)
n = n + 1
End

→ Checksum = 59H

## Interface commands for CP70 and CP25

In the following commands is:

x	=	place holder for entered and emitted values
qq	=	place holder for the Checksum

### Sensor Settings

Sensor Reset: The reset sets the switching points back to delivery status and deactivates time delays, filter functions or extra hysteresis.

**/000R4D.** answer: /020MRS51.

#### Foreground Teach Output A1:

**/020T1149.** answer: /030MT1105.

#### Background Teach Output A1:

**/020T124A.** answer: /030MT1206.

#### Foreground Teach Output A2:

**/020T214A.** answer: /030MT2106.

#### Background Teach Output A2:

**/020T2249.** answer: /030MT2205.

#### On-Delay Output A1:

**/030Y1xxqq.** answer: /040MY1xxqq. xx= 00...99  
Delay=xx times 10 ms

Example:

/030Y10175. Delay=10 ms answer: /040MY1013F.

#### On-Delay Output A2:

**/030Y2xxqq.** answer: /040MY2xxqq. xx= 00...99  
Delay=xx times 10 ms

Example:

/030Y20275. Delay=20 ms answer: /040MY2023F.

#### Off-Delay Output A1:

**/030Z1xxqq.** answer: /040MZ1xxqq. xx= 00...99  
Delay=xx times 10 ms

Example:

/030Z10572. Delay=50 ms answer: /040MZ10538.

## Off-Delay Output A2:

/030Z2xxqq.                      answer: /040MZ2xxqq.                      xx= 00...99  
Delay=xx times 10 ms

Example:

/030Z25071.                      Delay=500 ms                      answer: /040MZ2503B.

## Normally Open function Output A1:

/020A115C.                      answer: /030MA1110.

## Normally Closed function Output A1:

/020A105D.                      answer: /030MA1011.

## Normally Open function Output A2:

/020A215F.                      answer: /030MA2113.

## Normally Closed function Output A2:

/020A205E.                      answer: /030MA2012.

## Operate Outputs as PNP:

/020O0153. (O not 0)                      answer: /020MO12E.

## Operate Outputs as NPN:

/020O0250. (O not 0)                      answer: /020MO22D.

## Operate Outputs as Push-Pull:

/020O0351. (O not 0)                      answer: /020MO32C.

## Deactivate Laser:

/020L0051.                      answer: /020L0051.

## Activate Laser:

/020L0150.                      answer: /020L0150.

## Set Switching-On Point for Output 1: The switching-off point is calculated automatically via the hysteresis.

/060S1xxxxqq.                      answer: /020MS132.  
xxxx:                      Value in 1/100 mm

## Set Switching-On Point for Output 2: The switching-off point is calculated automatically via the hysteresis.

/060S2xxxxqq.                      answer: /020MS231.  
xxxx:                      Value in 1/100 mm

**Set switching-off point for output 1:** For flexible setting of the switching-off point resp. diminution of the switching hysteresis with the use of the filter function. Check switching function on sufficient hysteresis afterwards.

/060S3xxxxxqq.

Acceptance: /020MS332.  
Refuse: /020XS3qq.  
xxxxx: Value in 1/100 mm

**Set switching-off point for output 2:** For flexible setting of the switching-off point resp. diminution of the switching hysteresis with the use of the filter function. Check switching function on sufficient hysteresis afterwards.

/060S4xxxxxqq.

Acceptance: /020MS431.  
Refuse: /020XS4qq.  
xxxxx: Value in 1/100 mm

**Amplify Hysteresis at Output 1:** Reasonable e.g. in case of vibrations of the object.

/060H10xxxxqq.

answer: /020MH129.  
xxxx: Extra hysteresis in 1/100 mm

**Amplify Hysteresis at Output 2:** Reasonable e.g. in case of vibrations of the object.

/060H20xxxxqq.

answer: /020MH22A.  
xxxx: Extra hysteresis in 1/100 mm

**Set Maximal Exposure Time:** The sensor adjusts – up to a maximal value – its exposure time resp. light pulse time automatically to the detected object. In case of e. g. black or glossy objects it can be reasonable to increase this time. The reduction of the exposure time can be useful if the sensor is pointed towards light sources (delivery status CP25: 1000, CP70: 4000).

/060cr0xxxxqq.

answer: /060Mc0xxxxqq.  
xxxx: maximal exposure time (allowed 100...8000)

Example:

/060cr0800030. maximal exposure time=8000 answer: /060Mc080000F.

**Set filter function**

/030FSxxqq.

answer: /0030MFxxqq.  
xx: Number of filters for continuous average determination (allowed 0...99)

## Change baud rate

The baud rate of the sensor is standardized with 38400 baud. If you want to change the baud rate, proceed as follows. Open your hyper terminal and take the following settings: Baud rate: 38400, Data bit: 8, Stop bit: 1, Parity: none, Flow control: none. In order to change the baud rate, enter the following commands corresponding your desired baud rate.

The new baud rate is activated after the supply voltage is applied anew.

Function	Send Frame to the Sensor	Response Frame from the Sensor
Baud rate to 9600 Baud	/030?BR201.	/030Ade2qq.
Baud rate to 19200 Baud	/030?BR300.	/030Ade3qq.
Baud rate to 38400 Baud	/030?BR407.	/030Ade4qq.
Baud rate to 57600 Baud	/030?BR506.	/030Ade5qq.
Baud rate to 115200 Baud	/030?BR605.	/030Ade6qq.

## Query Sensor Settings and Values

### Query Sensor Version:

**/000V49.**                      answer: /070V8a:bbccqq.  
a:                      Software version  
bb:                      Sensor group  
cc:                      Sensor type

### Single Emission of Distance Values:

**/020D0e0C.**                      answer: /060Dxxxxnqq.  
xxxxx:                      Distance Value in 1/100 mm  
n:                      ASCII-Character NUL (hex: 00)

### Activate Permanent Emission of Distance Values:

**/020D0p19.**                      answer: /040D0P:134.                      Start of Permanent Distance Value Emission in format of the Single Emission (see above).  
xxxxx:                      Distance Value in 1/100 mm

### Deactivate Permanent Emission of Distance Values:

**/020D0a08.**                      answer: /040D0P:035.                      End of Permanent Distance Value Emission.

### Query Off-Delay Time for Output 1:

**/020WZ121.**                      answer: /050WZ10xxqq.  
xx times 10 ms:                      Off-Delay Time for Output A1 in ms



**Query Off-Delay Time for Output 2:**

**/020WZ222.** answer: /050WZ20xxqq. Off-Delay Time for Output A2 in ms  
xx times 10 ms:

**Query On-Delay Time for Output A1:**

**/020WZ323.** answer: /050WZ30xxqq. On-Delay Time for Output A1 in ms  
xx times 10 ms:

**Query On-Delay Time for Output A2:**

**/020WZ424.** answer: /050WZ40xxqq. On-Delay Time for Output A2 in ms  
xx times 10 ms:

**Query Switching-On Point for Output A1:**

**/020WC138.** answer: /070WC1xxxxqq. Switching-On Point for Output A1 in 1/100 mm  
xxxxx:

**Query Switching-On Point for Output A2:**

**/020WC23B.** answer: /070WC2xxxxqq. Switching-On Point for Output A2 in 1/100 mm  
xxxxx:

**Query Switching-Off Point for Output A1:**

**/020WD13F.** answer: /070WD1xxxxqq. Switching-Off Point for Output A1 in 1/100 mm  
xxxxx:

**Query Switching-Off Point for Output A2:**

**/020WD23C.** answer: /070WD2xxxxqq. Switching-Off Point for Output A2 in 1/100 mm  
xxxxx:

**Query Teach Mode for Output A1:**

**/020WT12F.** answer: /030WT1xqq. x=1 if VT, x=2 if HT

**Query Teach Mode for Output A2:**

**/020WT22C.** answer: /030WT2xqq. x=1 if VT, x=2 if HT

**Query Normally Open/ Normally Closed function for Output A1:**

**/020WA13A.** answer: /030WA1xqq. x=0 if NC, x=1 if NO

**Query Normally Open/ Normally Closed function for Output A2:**

**/020WA239.** answer: /030WA2xqq. x=0 if NC, x=1 if NO

## Query Error Status:

/020WE33C.

answer: /030WEfxqq.

x = 0 No error

x = 1 Error

f = 1 Error Output indicates Error Status

f = 0 Error Output indicates Normal Status

## Query Operating Mode of the Outputs:

/020WO336. (O nicht 0)

answer: /020WOxqq.

x = 1 if PNP

x = 2 if NPN

x = 3 if Push-Pull

## Query Switching Mode of the outputs:

/020WQ328.

answer: /040WQabcqq.

a: Switching mode output A1

b: Switching mode output A2

c: Switching mode error output

## Query Maximal Exposure Time:

/020WM334.

answer: /060WM0xxxxqq.

xxxx: maximum exposure time

## Query number measurement values for filter:

/020WF33F

answer: /040WF0xxqq.

xx: Number of measurement values for filter

## 8. Maintenance Instructions

- This wenglor sensor is maintenance-free.
- It is advisable to clean the lens and the display, and to check the plug connections at regular intervals.
- Do not clean with solvents or cleansers which could damage the device.

## 9. Proper Disposal

wenglor sensoric gmbh does not accept the return of unusable or irreparable products. Respectively valid national waste disposal regulations apply to product disposal.

## **10. EU Declaration of Conformity**

The EU declaration of conformity can be found on our website at [www.wenglor.com](http://www.wenglor.com) in download area.