

7800 SERIES: EC7895A,C; RM7895A,B,C,D; RM7896A,B,C,D RM7897A,C and RM7898A Relay Modules

SPECIFICATION DATA



APPLICATION

The Honeywell EC7895/RM7895/RM7896 is a microprocessor based integrated burner control for automatically fired gas, oil, or combination fuel single burner applications. A Relay Module, Subbase, Amplifier and Purge Card are required to complete the system. Options include Keyboard Display Module (KDM), Modbus™ Module, DATA CONTROLBUS MODULE™, Remote Display mounting, and First-Out Expanded Annunciator.

The Relay Module is programmed to provide a level of safety, functional capability and features beyond the capacity of conventional controls.

Functions provided by the Relay Module include

- Automatic burner sequencing
- Flame supervision
- System status indication
- System or self-diagnostics
- Troubleshooting
- RM7896 provides 15 seconds postpurge.

The RM7897 adds:

- Proof of closure input to the standard primary control function of the RM7895/RM7896 product.
- A blinking fault code function to the POWER LED on Alarm shutdown.
- Programmable postpurge using the S7800A1142 Keyboard Display Module (KDM).

The RM7897A1002 offers selectable pilot operation, intermittent on terminal 8 or interrupted on terminal 21. The RM7897C1000 offers interrupted pilot and delayed main valve for 2-step firing (Low-High-Low) applications.

The RM7897C1018 has 4 second MFEP (main flame establishing period).

The RM7897C1026 provides a special recycle function for configuration of Jumper JR2:

- JR 2 intact: Recycle on loss of flame.
- JR2 clipped: If flame loss occurs during the first 15 seconds in the Run period, then lockout occurs. If flame loss occurs after 15 seconds into the Run period, then recycle.

Factory default for postpurge time: 0 seconds.

The RM7898 provides unique functions to a standard primary control.

As received, the RM7898 offers the following features:

- Interrupted pilot with 10 second pilot flame establishing period.
- Main valve operation with 10 second MFEP.
- Pre-Ignition Interlock (POC) input.
- Shutter-driven output when appropriate amplifier is selected (R7861A, R7886A, R7851C).
- Blinking Fault Code Power LED on safety shutdown.
- Programmable postpurge using the S7800A1142 KDM - factory default time: 0 seconds.

RM7898A1018 offers early spark shutoff when flame is sensed.

Available features when appropriate terminals are energized:

- Intermittent pilot T8 (Terminal 19).
- Direct spark feature for Valve Proving System (VPS) (Terminal 18).
- Valve Proving System function (Terminal 17).

Programmable features using the S7800A1142 Keyboard Display Module (KDM) (not included):

- Postpurge time—(up to 60 minutes).
- Valve Prove System features, including:
 - VPS test time
 - When in burner sequence to conduct VPS time (Never, Before, After, Both or Split)



(RM7897, RM7898 only)



66-2026-05

FEATURES

- Safety features:
 - Interlock check.
 - Closed loop logic test.
 - Dynamic AMPLI-CHECK®.
 - Dynamic input check.
 - Dynamic safety relay test.
 - Dynamic self-check logic.
 - Internal hardware status monitoring.
 - Tamper resistant timing and logic.
- Access for external electrical voltage checks.
- Airflow switch check feature (RM7895B,D/RM7896B,D).
- Communication interface capability using Modbus.
- Delayed main valve (EC7895C; RM7895C,D; RM7896C,D; RM7897C)
- The Relay Module provides either 0.8 or 3 second Flame Failure Response Time (FFRT), depending on the amplifier selected.
- Dependable, long-term operation provided by microcomputer technology.
- First-out annunciation and system diagnostics are provided by a 2 row by 20 column Vacuum Fluorescent Display (VFD) located on the optional Keyboard Display Module.
- First-out expanded annunciation with 26 Light Emitting Diodes (LED) for limits and interlocks (optional).
- Five (LED) for sequence information, see Fig. 1.
- Two function Run/Test Switch (EC7895C; RM7895C,D; RM7896C,D; RM7897; RM7898).
- Interchangeable plug-in flame amplifiers.
- Local or remote annunciation of EC7895/RM7895 and RM7896 operation and fault information (optional).
- Nonvolatile memory; retains history files and sequencing status after loss of power.
- Remote reset (optional).
- Selectable recycle or lockout on loss of airflow.
- Selectable recycle or lockout on loss of flame (RM7895C1053 does not have the selectable option. It locks out on loss of flame.)
- Shutter drive output.
- Burner controller data (optional):
 - Expanded annunciator status.
 - Flame signal strength.
 - Hold status.
 - Lockout/alarm status.
 - Sequence status.
 - Sequence time.
 - Total cycles of operation.
 - Total hours of operation.
 - Fault history providing for the six most recent faults:
 - Cycles of operation at the time of the fault.
 - Expanded annunciator data at the time of the fault.
 - Fault message and code.
 - Hours of operation at the time of the fault.
 - Sequence status at the time of the fault.
 - Sequence time at the time of the fault.
 - Diagnostic information:
 - Device type.
 - Flame amplifier type.
 - Flame failure response time.
 - Manufacturing code.
 - On/Off status of all digital inputs and outputs.
 - Selected prepurge time.
 - Software revision and version of EC7895/RM7895/RM7896 and optional Keyboard Display Module.
 - Status of configuration jumpers.
- Status of Run/Test Switch (EC7895C/RM7895C,D/RM7896C,D; RM7897; RM7898).

SPECIFICATIONS

Dimensions: See Fig. 2.

Electrical Ratings, see Table 1:

Voltage and Frequency:

EC7895A,C: 220 to 240 Vac (+10/-15%), 50 or 60 Hz (±10%).

RM7895/RM7896: 120 Vac (+10/-15%), 50 or 60 Hz (±10%).

Power Dissipation:

10W maximum.

Maximum Total Connected Load: 2000 VA.

Fusing: Total Connected Load: 15A type SC or equivalent, fast-acting fuse.

Environmental Ratings:

Ambient Temperature:

Operating: -40°F to +140°F (-40°C to +60°C).

Storage: -60°F to +150°F (-40°C to +66°C).

Humidity: 85% RH continuous, noncondensing.

Vibration: 0.5G environment.

Weight: 1 pound 13 ounces, unpacked.

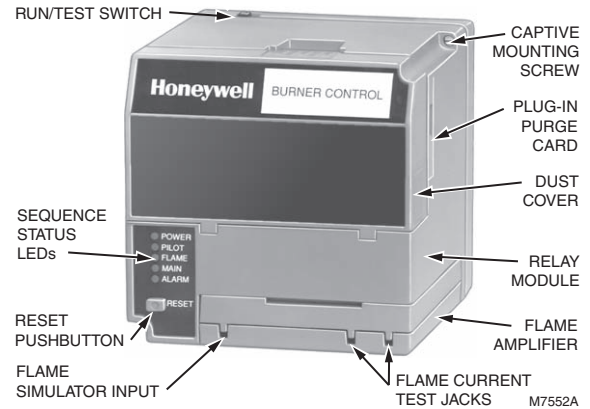

Fig. 1. Relay Module and sequence status LEDs.

Table 1. Terminal Ratings.

Terminal Number	Description	Ratings	
		RM7895/RM7896/RM7897	EC7895
G	Flame Sensor Ground	—	—
Earth G	Earth Ground ^a	—	—
L2(N)	Line Voltage Common	—	—
3	Alarm	120 Vac, 1A pilot duty.	220 to 240 Vac, 1A pilot duty.
4	Burner Motor	120 Vac, 9.8AFL, 58.8ALR (inrush).	220 to 240 Vac, 4A @ PF =0.5, 20A inrush.
5	Line Voltage Supply (L1)	120 Vac (+10%/-15%), 50 or 60 Hz (±10%) ^b .	220 to 240 Vac (+10%/-15%), 50 or 60 Hz (±10%).
6	Burner Control and Limits	120 Vac, 1 mA.	220 to 240 Vac, 1 mA.
7	Airflow Interlock	120 Vac, 8A run, 43A inrush.	8A @ PF= 0.5, 40A inrush, 2A @ PF = 0.2.
8	Pilot Valve/Ignition	120 Vac ^c .	220 to 240 Vac, 4A @ PF = 0.5, 20A inrush.
9	Main Fuel Valve	120 Vac ^c .	220 to 240 Vac, 4A @ PF = 0.5, 20A inrush.
10	Ignition	120 Vac ^c .	220 to 240 Vac, 2A @ PF = 0.2.
F(11)	Flame Sensor	60 to 220 Vac, current limited.	60 to 220 Vac, current limited.
12 to 20	Unused	—	—
20 (RM7897 only)	Pre-ignition Interlock	120Vac.	1mA
21	Delayed Main Valve (EC7895C, RM7895C, RM7896C,D)	120 Vac ^c .	220 to 240 Vac, 4A @ PF = 0.5, 20A inrush.
22	Shutter	120 Vac, 0.5A.	220 to 240 Vac ^d .

^a The relay module must have an earth ground providing a connection between the subbase and the control panel or the equipment. The earth ground wire must be capable of conducting the current to blow the 20A fuse (or breaker) in event of an internal short circuit. The relay module needs a low impedance ground connection to the equipment frame which, in turn, needs a low impedance to earth ground.

^b 2000 VA maximum connected load to relay module.

^c See Table 4 and 5.

^d 220 to 240 Vac application. Requires 220 to 240 Vac to 120 Vac, 10 VA stepdown transformer to operate the shutter.

Table 2. RM7898 Terminal Ratings.

Terminal Number	Description	Ratings
		RM7898
G	Flame Sensor Ground	—
Earth G	Earth Ground ^a	—
L2(N)	Line Voltage Common	—
3	Alarm	120 Vac, 1A pilot duty.
4	Burner Motor	120 Vac, 9.8A AFL, 58.8 ALR (inrush).
5	Line Voltage Supply (L1)	120 Vac (+10/-15%), 50 or 60 Hz ($\pm 10\%$). ^b
6 or 17	Burner Controller and Limits	120 Vac, 1 mA.
7	Lockout Interlock	120 Vac, 8A run, 43A inrush.
8	Pilot Valve/Ignition	120 Vac ^c
9	Main Fuel Valve	120 Vac ^c
10	Ignition	120 Vac ^c
F(11)	Flame Sensor	60 to 220 Vac, current limited.
12 to 15	— Not Used	—
16	Valve Proven Pressure Switch Impact	120Vac, 1mA.
17	Demand Input for Valve Proven Feature	120 Vac 1mA.
18	DSI for Valve Proving Enable	120 Vac 1mA.
19	Intermittent Pilot Enable (terminal 8)	120 Vac 1mA.
20	Pre-Ignition Interlock	120 Vac, 1 mA.
21	2nd Stage Main Valve	120 Vac ^c
22	Shutter	120 Vac, 0.5A

^a The relay module must have an earth ground providing a connection between the subbase and the control panel or the equipment. The earth ground wire must be capable of conducting the current to blow the 20A fuse (or breaker) in event of an internal short circuit. The relay module needs a low impedance ground connection to the equipment frame which, in turn, needs a low impedance to earth ground.

^b 2000 VA maximum load connected to RM7898 Assembly.

^c See Table 4 and 5.

Table 3. Sequence timing for normal operation.

Device	Initiate	Standby ^a	Purge ^b	Flame Establishing Period		AFSC ^c	DMV ^d	
				Pilot	Main			
EC7895A/RM7895A, RM7896A, RM7897A ^g	10 sec.			4 or 10 sec.	No	No	No	
RM7895B/RM7896B						Yes		
EC7895C/RM7895C/ RM7896C/RM7897C, RM7898 ^h				4 or 10 sec. ^{e,f}	10 sec.	No		Yes
RM7895D/RM7896D				4 or 10 sec.	10 sec.	Yes		

^a STANDBY and RUN can be an infinite time period.

^b PURGE will be determined by which ST7800 Purge Card is selected.

^c AFSC is a dynamic Air Flow Switch Check.

^d DMV is Delayed Main Valve.

^e RM7895C1020, RM7896C1036 have a fixed Pilot Flame Establishing Period of 10 seconds.

^f RM7895C1053, RM7897C1018 have a fixed Pilot Flame Establishing Period of 4 seconds.

^g RM7897A has intermittent pilot (terminal 8) or interrupted pilot (terminal 21).

^h RM7898 provides intermittent pilot (terminal 8) when power is applied to terminal 19.

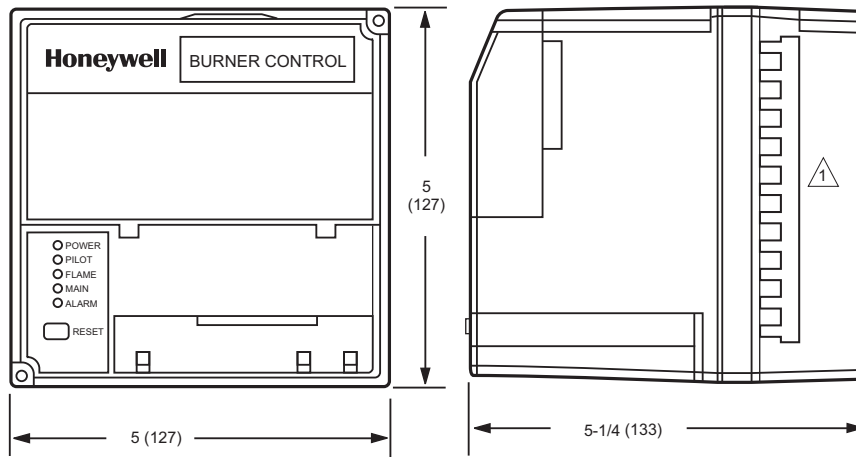

1 REMOVE ONLY FOR TERMINAL TEST ACCESS.

M5003A

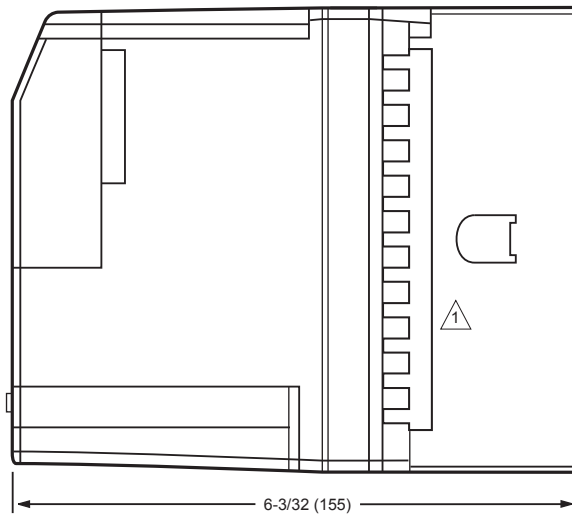

M17791

Fig. 2. Mounting dimensions of Relay Module, Q7800A Subbase and Q7800B Subbase, respectively, in in. (mm).

Table 4. Combinations for terminals 8, 9, 10 and 21.

Pilot Fuel 8	Main 9	Ignition 10	Delayed Main Valve 21
C	F	No Load	No Load
B	F	No Load	No Load
F ^a	No Load	No Load	No Load
F	F	A	No Load
F ^a	No Load	A	F
D	F	A	No Load
D ^a	No Load	A	D
D	D	A	No Load
D ^a	No Load	A	D

^a RM7895C,D: EC7895C, RM7896C,D Jumper terminals 8-9.

Table 5. Composition of each combination.

A.	B.	C.	D.	F.
4.5A ignition	50 VA Pilot Duty ^a plus 4.5A Ignition.	180 VA Ignition plus Motor valves with: 660 VA inrush, 360 VA open, 250 VA hold.	2A Pilot Duty. ^a	65 VA Pilot Duty ^a plus Motor valves with: 3850 VA inrush, 700 VA open, 250 VA hold.

^a Pilot Duty relates to solenoid-type valves.

SIL3 Capable

RM7897/RM7898 are SIL3 Capable in a properly designed Safety Instrumented System. See form 65-0312 for certificate agreement.

Approval Bodies:

RM7895, RM7896 only:
Underwriters Laboratories Inc. listed, File No. MP268, Guide No. MCCZ.
Canadian Standards Association certified, LR9S329-3.
Factory Mutual Approved: 1V9A0.AF.
SwissRe (formerly IRI) acceptable.
Federal Communications Commission: Part 15, Class B—Emissions.

EC7895A,C:
Factory Mutual Report OYOA9.AF.

Mounting: Q7800A for panel mount or Q7800B for wall or burner mount.

Required Components:

Plug-in Flame Signal Amplifier, see Table 2.
Plug-in Purge Timer Cards: selectable ST7800A: two seconds to 30 minutes.
Wiring Subbase Q7800A or Q7800B.

Accessories:

Keyboard Display Modules (KDM):
S7800A1001 English language.
S7800A1035 French language.
S7800A1043 German language.
S7800A1050 Italian language.

S7800A1068 Spanish language.
S7800A1118 Katakana (Japanese) language.
S7800A1126 Portuguese language.
S7800A1142 English language (for postpurge or VPS programming)
S7800A1167 Spanish language (for postpurge or VPS programming)

Communications:

S7810A1009 Data ControlBus™ Module (if no KDM is used).
S7810M ModBus™ Module.

Miscellaneous:

A7800A1010 7800 SERIES Tester.
S7820A1007 Remote Reset Module.
S7830A1005 Expanded Annunciator, 120 Vac, 50/60 Hz.
203541 Data ControlBus Connector, 5-wire.
203765 Remote Display Mounting Bracket.
221729 Dust Cover, Relay Module.
50023821-001 Keyboard Display Module Cover, NEMA 4, clear.
204718B Keyboard Display Module Cover, NEMA 1, clear.
50023821-002 Keyboard Display Module Cover, NEMA 4, clear with reset button.
205321B Flush Display mounting kit.
221818A Extension Cable, display, 5 ft (1524 mm).
221818C Extension Cable, display, 10 ft (3048 mm).
123514A Rectification Flame Simulator.
203659 Ultraviolet Flame Simulator.

Table 6. Flame Detector System.

Plug-In Flame Signal Amplifiers					Applicable Flame Detectors		
Type	Color	Self-Checking	Model	Flame Failure Response Time	Fuel	Type	Models
Rectification	Green	No	R7847A	0.8 or 3 sec.	Gas	Rectifying Flame Rod Holders ^a	C7004, C7007 Complete Assemblies: C7005, C7008, C7009, Q179
				3 sec.	Gas, oil, coal	Ultraviolet (Purple Peeper)	C7012A,C ^b
		Dynamic AMPLI-CHECK™	R7847B ^c	0.8 or 3 sec.	Gas	Rectifying Flame Rod Holders ^a	C7004, C7007 Complete Assemblies: C7005, C7008, C7009, Q179
				3 sec.	Gas, oil, coal	Ultraviolet (Purple Peeper)	C7012A,C ^b
		Dynamic Self-Check	R7847C ^d			Ultraviolet (Purple Peeper)	C7012E,F
		Infrared	Red/White	No	R7852A		
Dynamic AMPLI-CHECK™	R7852B ^c						
Ultraviolet	Purple	No	R7849A	0.8 or 3 sec.	Gas, oil	Ultraviolet (Minipeeper)	C7027, C7035, C7044 ^b
			R7849B ^c				
		Dynamic Self-Check	R7861A ^d			Ultraviolet	C7061
	Blue	Dynamic Self-Check	R7886A ^d	3 sec.	Gas, oil, coal	Ultraviolet (Adjustable Sensitivity)	C7076
Optical	White	Dynamic AMPLI-CHECK™	R7851B ^c	0.8 or 3 sec.	Gas, oil, coal	Optical (Ultraviolet, visible light)	C7927, C7962

^a Order flame rod separately, see holder instructions.

^b The C7012A,C; C7027, C7035 and C7044 Flame Detectors should be used only on burners that cycle on-off at least once every twenty-four hours. Appliances with burners that remain on continuously for twenty-four hours or longer should use the C7012E,F Flame Detector with the R7847C Amplifier; the C7061 Flame Detector with the R7861 Amplifier, or the C7076 Flame Detector with the R7886A Amplifier as the ultraviolet flame detection system.

^c Circuitry tests the flame signal amplifier at least 12 times a minute during burner operation and shuts down the boiler if the amplifier fails.

^d Circuitry tests all electronic components in the flame detection system (amplifier and detector) 12 times a minute during burner operation and shuts down the burner if the detection system fails.

Automation and Control Solutions

Honeywell International Inc.
1985 Douglas Drive North
Golden Valley, MN 55422
customer.honeywell.com

© U.S. Registered Trademark
© 2013 Honeywell International Inc.
66-2026—05 M.S. Rev. 12-13
Printed in United States

Honeywell