

Communication

IFM Modbus communication interface

P619111_17.eps



IFM Modbus communication interface.
Ref.: LV434000.

A

DB425689.eps

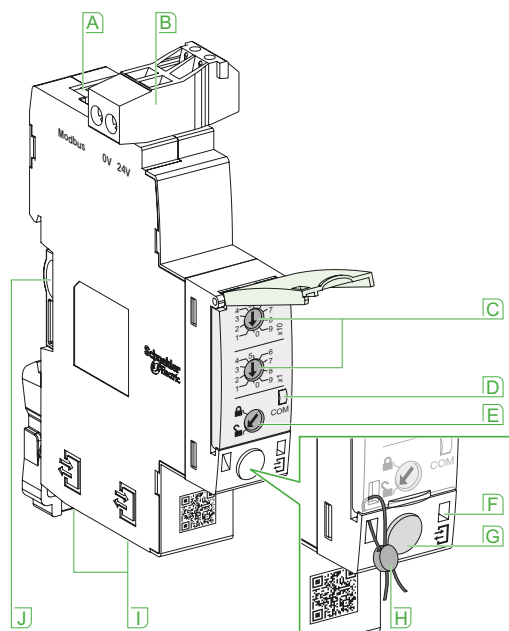

- A** Modbus screw clamp connector.
- B** Modbus address switches.
- C** Modbus traffic LED.
- D** Modbus locking pad.
- E** ULP activity LED.
- F** Test button.
- G** Mechanical lock.
- H** ULP RJ45 connectors.
- I** Stacking accessory connection.

Simplified IFM installation

Stacking IFM

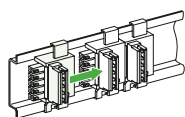

Stacking accessories

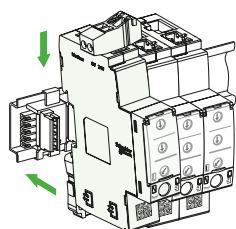

Up to 12 stacked IFM

Function

IFM - Modbus communication interface - is required for connecting MasterPact MTZ, NT/ NW or ComPact NS and NSX to Modbus network whenever the circuit breaker has an ULP port (Universal Logic Plug). The port is available on BCM ULP for MasterPact range and BSCM module for ComPact range.

Note: IFM is defined as an IMU (Intelligent Modular Unit) within the ULP connection System documentation.

Once connected to IFM, the circuit breaker is considered as a slave by the Modbus master. Its electrical values, alarm status, open/close signals can be monitored or controlled by a Programmable Logic Controller or any other system.

Characteristics

ULP port

2 RJ45 sockets, internal parallel wiring.

- Connection of a single circuit breaker.
- An ULP line terminator must be connected to the second RJ45 ULP socket. The RJ45 sockets deliver a 24 V DC supply fed from the Modbus socket.

Built-in test function, for checking the correct connection to the circuit breaker.

Modbus slave port

- Modbus Serial RJ45 port - RJ45 connector provides fast and reliable wiring.
- Lateral socket, for DIN rail stackable connector.
- Both top and lateral sockets are internally parallel wired.
- Multiple IFM can be stacked, thus sharing a common power supply and Modbus line without individual wiring.
- On the front face:
 - Modbus address setting (1 to 99): 2 coded rotary switches
 - Modbus locking pad: enables or disable the circuit breaker remote control and modification of IFM parameters.
 - Self adjusting communication format (Baud rate, parity).

24 V DC power supply

- Screw clamp terminal block
- High electrical insulation between Modbus and 24 V DC connectors
- Separated lines provides improved communication robustness.

Technical characteristics

General characteristics

Environmental Characteristics

Conforming to standards	IEC 61010, IEC 60950, UL 61010, UL 60950, CISPR 22, 24, 11, IACS E10
Certification	c UL us, CE, EAC, FCC marking
Ambient temperature	-20 to +70 °C
Relative humidity	5 - 85 %
Level of pollution	Level 3
Protective treatment	ULV0 conforming to IEC/EN 60068-2-30

Mechanical characteristics

Shock resistance	Conforming to IEC/EN 60068-2-27 15 g / 11 ms, 1/2 sinusoidal
Resistance to sinusoidal vibrations	Conforming to IEC/EN 60068-2-6 5 Hz < f < 8.4 Hz

Electrical characteristics

Consumption	30 mA at 24 V DC
Resistance to electrostatic discharge	IEC/EN 61000-4-2: 8 kV AD
Immunity to radiated fields	IEC/EN 61000-4-3: 10 V/m
Immunity to surges	IEC/EN 61000-4-5: class 2

Physical characteristics

Dimensions	109 x 73 x 18 mm
Mounting	DIN rail
Weight	120 g
Degree of protection of the installed module	<ul style="list-style-type: none"> ■ IP20 for connectors ■ IP30 for other areas ■ RJ45 for ULP and Modbus SL ■ Screw type terminals for Power
Connections	

Stacking an IFE interface + gateway with IFM

