

---

## MSM-1-N-AA-QQQ-B1-137610 (ORDER NO. 137610)

Submodule MSM-1-N... (blanking cover with 3 adhesive labels)

- ▶ Function expansion for modules MGB2 and MCM
- ▶ Connection type: N
- ▶ 3 cut-outs for slide-in labels
- ▶ incl. transparent label holder (AY-C-A1-156732)
- ▶ incl. slide-in labels



Description

Dimension drawings

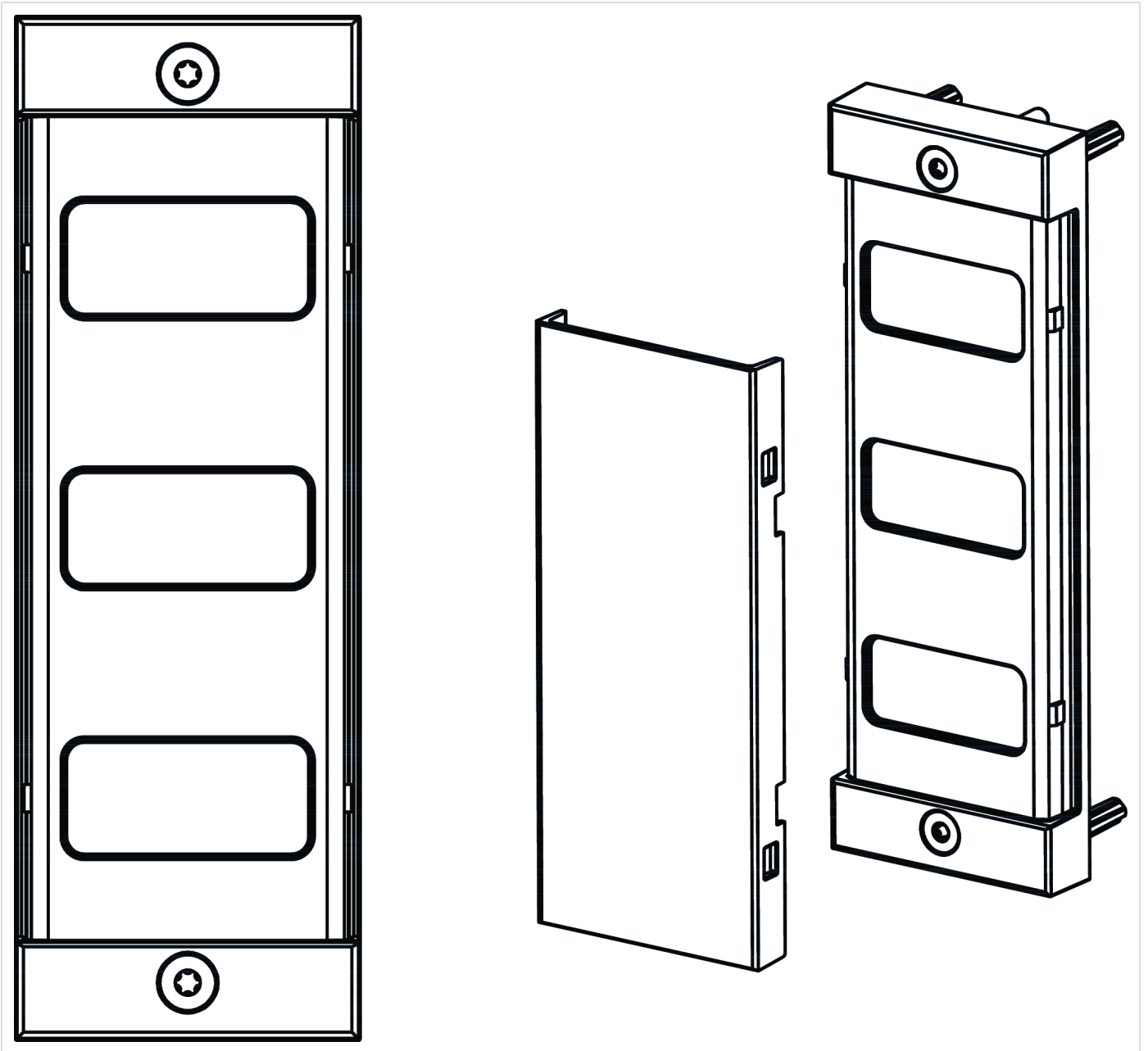

Dimension drawings

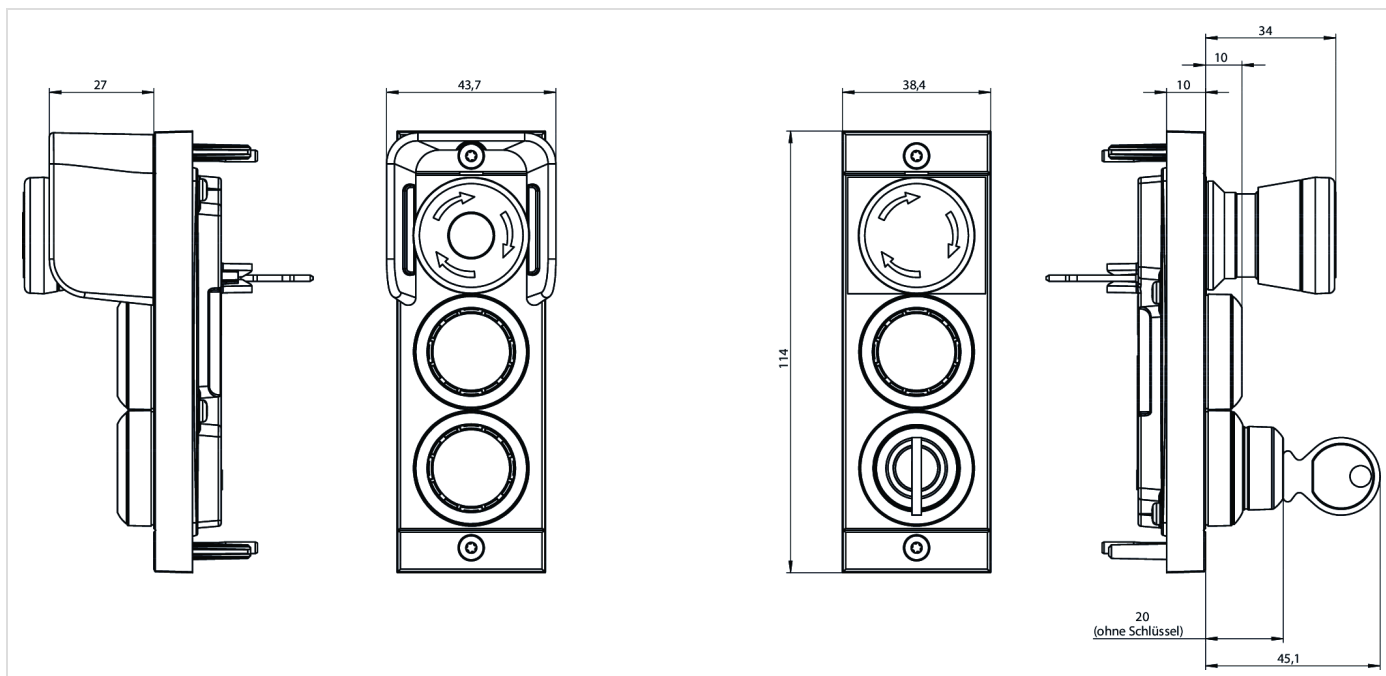

## Technical data

### Controls and indicators

Item	Extras	Color	Designation1	Number	LED	Switching element	Version	Einlegeschild Anmerkung	Slide-in label
S1							Position for slide-in label		
S2							Position for slide-in label		
S3							Position for slide-in label		

### Mechanical values and environment

Ambient temperature

at UB = 24V DC -25 ... +55 °C

Installation orientation

any

Material

Fiber glass reinforced plastic

Shock and vibration resistance

according to EN 60947-5-3

### Miscellaneous

Additional feature

incl. label holder ID no. 156732

Slide-in label

Anzahl

Beschriftung

Anmerkung

3

ohne Aufschrift

### Accessories

### Miscellaneous

## Adhesive labels

---

**114529**  
MGB-A-PLATESET-NN01-114529

- ▶ Adhesive labels suitable for MGB evaluation modules, bus modules and control modules
- ▶ silver, blank
- ▶ Packaging unit = 10 pcs.

## Mounting accessories

### Label holder for submodules MSM

---

**156732**  
AY-C-A1-156732

- ▶ Transparent label holder for submodule MSM-1-N-AA-QQ-B1-137610
- ▶ Easy and quick mounting

## Contacts

🏠 EUCHNER GmbH + Co. KG  
Kohlhammerstraße 16  
70771 Leinfelden-Echterdingen

☎ +49 711 7597-0

📠 +49 711 753316

✉ info(at)euchner.de