



Magnetic sensor

RC 60 1Sr-1m

Material number: 1184922 (Material number old: 26020102)

Features/Options:

- Thermoplastic enclosure
- Long life
- 1 Reed contact
- Actuation from front and from side
- Switching distance up to 33 mm depending on the actuating magnet
- With pre-wired cable

Notes

- 1 mounting nut is included in delivery
- The actuator is not included in the delivery of the switches

Dimensions

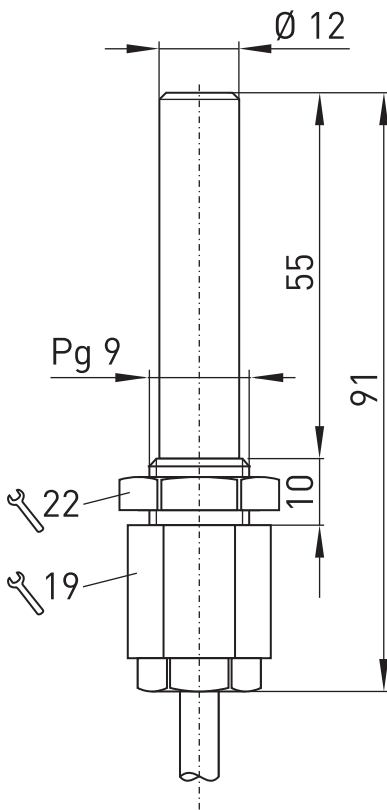

Technical data

Applied standards	EN 60947-5-2
Enclosure	polyamide, glass-fibre reinforced
Degree of protection	IP 67 to IEC/EN 60529
Switching system	reed contacts
Switching elements	1 bistable contact
Connection	pre-wired cable PVC
Cable cross-section	2 x 0.5 mm ²
Cable length	1 m
Switching voltage	max. 250 VAC/DC
Switching current	max. 2 A
Switching capacity	max. 50 W/VA
Switching frequency	max. 200 Hz
Ambient temperature	-10 °C ... +80 °C
Mechanical life	10 ⁹ operations
Electrical life	10 ⁹ operations
Repeatability	± 0.02 mm
Vibration resistance	20 g
Weight	66 g

Errors and omissions excepted.



Magnetic sensor

RC 60 1Sr-1m

Material number: 1184922 (Material number old: 26020102)

Contact diagram

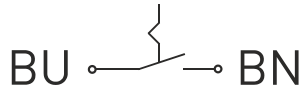



Magnetic sensor

RC 60 1Sr-1m

Material number: 1184922 (Material number old: 26020102)

Directive for the protection of reed contacts

1.) Protective circuit for inductive load to DC voltage

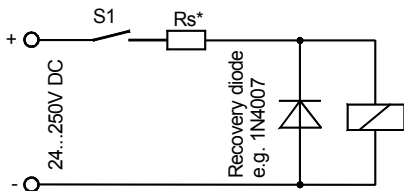

coil voltage Ue	serial resistor Rs
24 VDC	27 Ohm / 0.6 W
48 VDC	51 Ohm / 0.6 W

2.) Protective circuit for inductive load to AC voltage

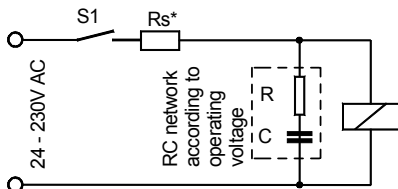

Permitted values for RC elements

coil voltage Ue	capacity C	resistor R	resistor Rs
24 VAC	0,1 µF	100 Ohm	27 Ohm/0,6 W
48 VAC	0,1 µF	220 Ohm	75 Ohm/0,6 W
115 VAC	0,1 µF	330 Ohm	180 Ohm/0,6 W
230 VAC	0,1 µF	470 Ohm	330 Ohm/0,6 W

3.) Protective circuit for capacitive load on DC / AC voltage

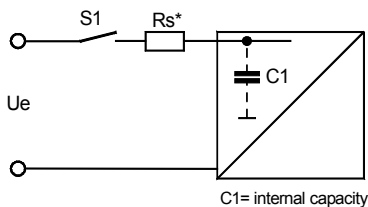

coil voltage Ue	serial resistor Rs
24 VDC	27 Ohm / 0.6 W
24 VAC	39 Ohm / 0.6 W
230 VAC	330 Ohm / 0.6 W

*Due to the cable capacitances it is necessary to place the series resistors Rs as near as possible to the reed contact, in general the next terminal point (junction box). For cable length > 5m. $R_s \ll R_L$ or R

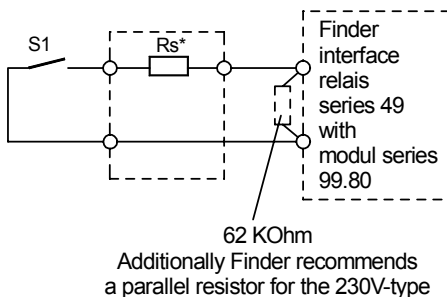

With unknown input currents, input capacitances we recommend the interposing of an interface relay. When using Finder relays series 49, in the following you will find some proposals to protect the reed contact against overload.

coil voltage Ue	serial resistor Rs
24 VDC	27 Ohm / 0.6 W
24 VAC	39 Ohm / 0.6 W
230 VAC	330 Ohm / 0.6 W