



HMI-70R

Multifunction Counter with
Ratemeter, Batch or Print Capability

Installation and Maintenance Instructions



1. Safety Information
2. General Information
3. Installation
4. Commissioning

Safety Information

Please read this instruction manual entirely and carefully before installation and start-up. Please observe all warnings and advice, both for your own safety and for general plant safety. If the device is not used in accordance with this instruction manual, then the intended protection can be impaired.

1.1 Safety Instructions and Warnings

Please use the device only if its technical condition is perfect, it should be used only for its intended purpose. Please bear in mind safety aspects and potential dangers and adhere to the operating instructions at all times. Defective or damaged devices should be disconnected immediately and taken out of operation. The device shall not be opened. Use the repair service offered by Kempston Controls only. Only connect the device to the electricity networks provided to that purpose.

The safety of the system in which the device is integrated is the responsibility of the installer.

Disconnect all electricity networks prior to any installation or maintenance work.

Use exclusively cables approved in your country and designed for your temperature and power ranges. Installation and service work shall be carried out exclusively by qualified personnel.

The device must compulsorily be protected with approved external fuses. The value of these fuses can be found in the installation section.

1.2 Use According to the Intended Purpose

The preset counter detects and measures pulses up to a max. 30 kHz and offers a wide variety of different operating modes. At the same time, the preset counter processes programmed presets. Use for any purpose over and beyond this will be deemed as not in accordance with its intended purpose and thus not complying with the requirements.

The application area for this device lies in industrial processes and controls, in the fields of manufacturing lines for the metal, wood, plastics, paper, glass, textile and other like industries. Over-voltages at the terminals of the device must be kept within the limits of over-voltage Category II.

The device must only be operated when mounted in a panel in the correct way and in accordance with the installation section. Mount the device away from heat sources and avoid direct contact with corrosive liquids, hot steam or similar. Provide a free space of 10mm all around the device for its ventilation. The device should be mounted so that the terminals are out of reach of the operator and cannot be touched by him. When mounting the device, consider the fact that only the front face is classified as accessible for the operator.

Safety Information

1.3 Hazardous Environments

The device is not suitable for use in hazardous areas and for areas excluded in EN 61010. If the device is used to monitor machines or processes in which, in the event of a failure or the device or an error made by the operator, there might be the risk of damaging the machine or causing an accident to the operators, It is your responsibility to take the appropriate safety measures.

1.4 Outdoor Usage

The device has been designed for indoor operation. It may nevertheless be used outdoors, provided the technical data is adhered to. In this case, take care to provide suitable UV protection.

1.5 Electrical Installation

The device must be disconnected from any power supply prior to installation or maintenance work. Make sure that no voltages liable to cause electrocution are present. Installation or maintenance work must only be carried out by qualified personnel and in compliance with the applicable national and international standards. The relay outputs are not protected internally in the device. Without suitable protection of the relay outputs, undesired heat development or even fire may occur. The relay outputs must be protected externally. It must also be made sure that, even in the case of a malfunction, the values stated in the installation section are under no circumstances exceeded.

1.6 Cleaning and Maintenance

The front face of the unit should only be cleaned with water via a soft damp cloth. Cleaning of the embedded rear side is not planned and is the responsibility of the service personnel or of the installer.

In normal operation this device is maintenance-free. Should the device nevertheless not operate properly, it must be sent back to Kempston Controls. Opening and repairing the device by the user is not allowed and can adversely affect the original protection level.

General Information

2.1 Description

The HMI-70R is a two preset counter intended for the control measurement of your product. An encoder can be directly in contact with your product via a wheel or roller, or can be connected indirectly to the drive system—even if the system is moving continually using the gate function.

The HMI-70R offers you a clear and user-friendly interface to help streamline and automate your process. Have confidence of your products exact length and save money on overcuts or costly returns from miss-measured product.

2.2 Principal Features

- 7.0 Inch Colour Touch Screen
- Large Digits & High Contrast Text
- 5 Control Inputs, 4 Relay Outputs
- 30kHz High Speed Counter
- IP66 Front, Easy to Clean
- Compact, Just 43mm Deep
- Automatic Power Saving Mode
- Metric & Imperial Toggle
- Pin Protected Pages
- Ethernet or RS232 Expansions
- External & Automatic Reset

2.3 The System

A typical system consists of a motor connected through a motor inverter with the capability of multiple speed presets. The HMI-70R incorporates two NO and NC relay outputs which can be used in conjunction to trigger a slow-down when you are close to your desired length and then completely stop the motor inverter when your target is reached. These outputs could also loop through to a switch or foot pedal for the operator or external alarms & alerts.

- All relays share the same common. If you have devices with different AC/DC inputs or that are outside of the relays ratings, please consider expanding with external relays.

General Information

2.4 Technical Data

Display	7.0 Inch Touchscreen TFT LCD. 25mm High Digits on Top Line. Green to Red when Target is met.
Presets	2x NO + NC Relay Outputs for Slowdown and Stop.
Input Modes	Count with Speed & Batch. Count with Print & Batch.
Count Inputs	A & B (30kHz)
Count Ranges	0 to 99999 0 to 9999.9 0 to 999.99
Screensaver	10 Minutes of Inactivity

2.5 Electrical Data

Current w/o Load	<190mA
External Fuse	315mA
Power Supply	20.4 to 28.8VDC
Output Relays	0 to 30VDC / 0 to 250VAC Max 3A Per Relay / Max 8A Common
Incremental Encoder	HTL 17 to 28.8VDC
Control Inputs	PNP 17 to 28.8VDC

General Information

2.6 Mechanical Data

Mounting Type	Panel Mounted
Size	210 x 146.4 x 42.3mm
Cut-Out	193 x 125mm
Weight	730 Grams Approx.

2.7 Ambient Conditions

Operating Temperature	0 to 50°C
Storage Temperature	-20 to 60°C
Operating Altitude	2000m
Environmental Protection	IP66 / NEMA4X
Relative Humidity	10% to 95% (non-condensing)

Installation

3.1 Mechanical Installation

When panel mounting the HMI-70R, pay close attention to both the safety and environmental limitations. Failing to do so may result in premature failure or create a safety hazard.

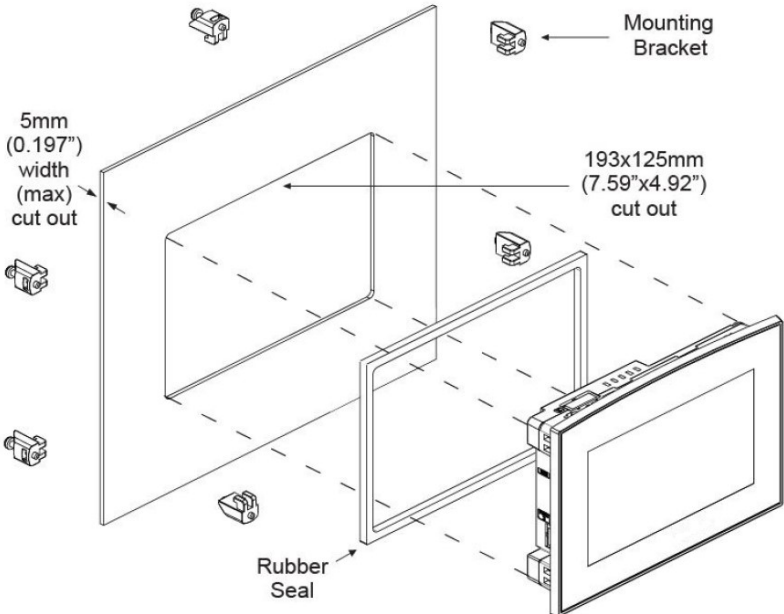
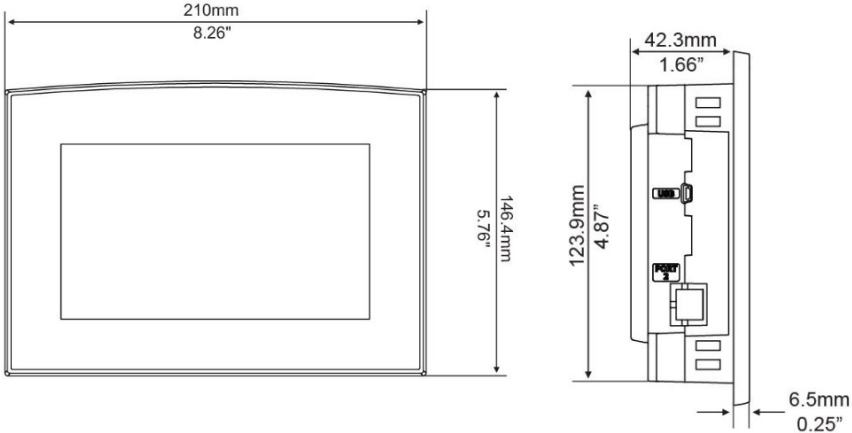

Installation

3.2 Electrical Installation

The electrical installation should be carried out by qualified personnel only, ensuring that relevant health and safety precautions are followed.

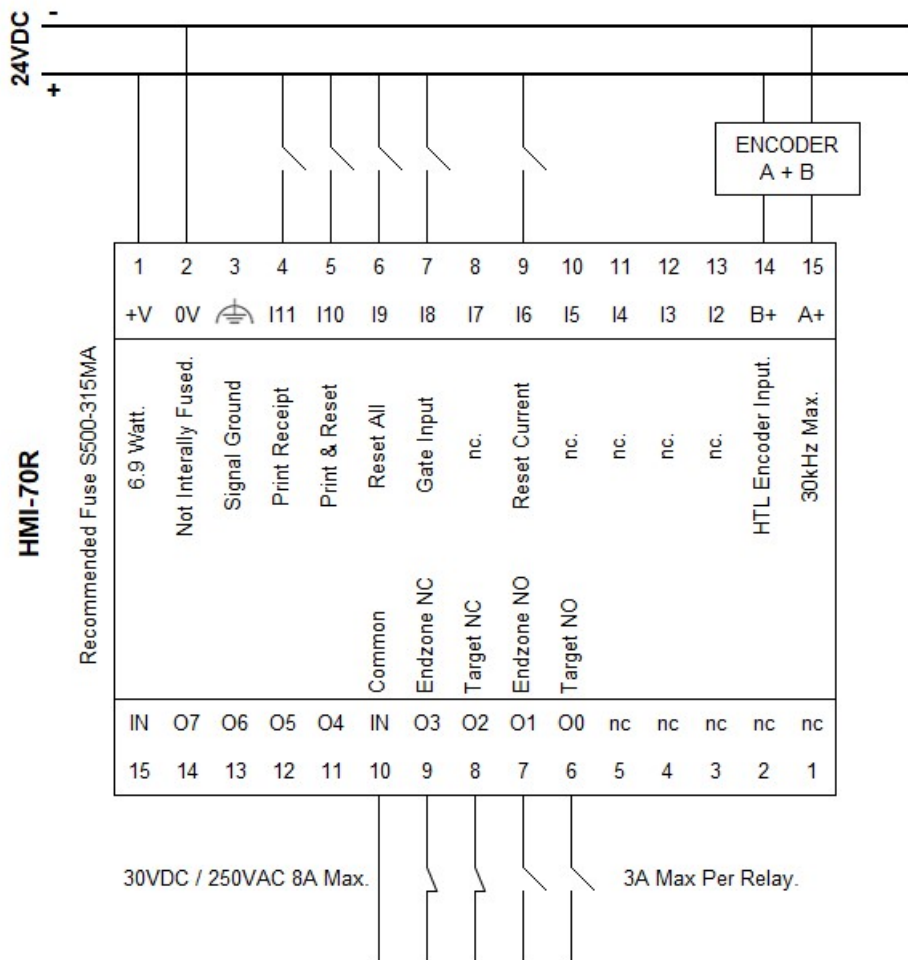

Commissioning

4.1 First Power-up

Upon powering up for the first time, you will be asked to select between two count modes. You will only be prompted to make this selection once, after which you will need to factory reset the device to be prompted again.



– **Print Mode**

The print mode works for both printers we offer, TFA-1079 adhesive label printer and TFA-1080 thermal ticket printer, both of which require the RS232 output card TFA-1077.

– **Standard Mode**

The standard mode gives you a speed readout as your process runs, at a glance allowing you to approximate how long is left on the job/run. This display proves crucial on applications like laminators where the speed of the run effects the end product.

Both modes will display a running total of length measured, allowing you to see your total production for a given time, this count requires a passcode to reset to prevent tampering.

Commissioning

4.2 Setup Pages

Once you have selected your desired mode, the home screen will permanently change to have two buttons, setup and run. The run button will not work initially, until you have configured your settings for the first time.



To enter the setup, press the setup button and then enter the default passcode 8888 in the keypad and press enter.

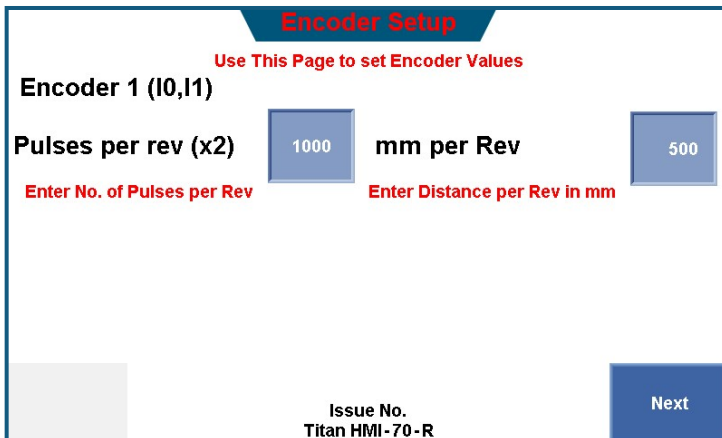

Enter the PPR of your encoder multiplied by 2 for quadrature, and secondly the distance in MM equivalent to 1 full encoder turn. In the example above, we have a 500PPR encoder connected to a 500mm wheel.

Commissioning

4.2 Setup Pages

The next page has a much broader range of settings, listed below are all the functions and their action.

Endzone value is the distance before the target that you want your first output to trigger. In the example below, if the target is 10m the endzone will trigger at 8m.

Auto reset delay dictates how long after the target is reached you want the counter to reset itself and start over. This is used for semi and fully automated processes, for no automatic reset, set to 00.00.

Output mode should be set to manual if you do not have an auto-reset or automatic if you are using the auto-reset.

The screenshot displays the 'General Setup' screen with the following settings and controls:

- End zone Value:** 2.0 m
- Auto reset delay:** 00.00
- Batch Count:** Enabled
- Factory Reset:** A grey button.
- Output Mode:** Manual
- Eng unit:** m (with a unit selection arrow button to the left)
- DP position:** 2

At the bottom of the screen, there are three buttons: 'Run', 'Admin', and 'Next'. A red text prompt reads 'Press Run to Start Counting.....'. The bottom status bar shows 'Issue No. Titan HMI - 70 - R'.

Disable the batch count if you do not want batch to appear on your print ticket, or simply do not want to record this.

The current count can display to 0, 1 or 2 decimal places with 5 figures maximum. Batch will always display without decimals and speed always with 2 decimals.

The factory reset button will completely wipe the PLC and return you to the selection of count mode (print/batch/standard). Please note this wipes all current parameters and reverts them back to our default parameters. Make a note of all your parameters prior to performing a factory reset.

Press admin and enter the default pin to enter the final setup page.

Commissioning

4.2 Setup Pages

The final page holds more specific features.

Admin pin is the code required to enter the setup pages (including this one).
The supervisor pin is the pin required to reset the batch count.

If changing the admin pin, it is your responsibility to remember the new code, otherwise you will be locked out of the settings.

The screenshot shows a 'Pin Code Setup' screen with a red warning message: '***Please apply a pin code for Admin and Supervisor Users. Please Note that you must remember these pin codes for future use'. The screen contains several settings:

Set Admin Pin	8888	Set Supervisor Pin	8888
Initialize and Reset		Screen Saver	Enabled
Reset PLC		Time Change	17:47:49
Printer Type	<> ZEBRA		Setup

Initialize and reset should only be used after consulting with Kempston. This is required in the case of a PLC glitch and is similar to a factory reset. This will wipe all settings from the unit, ensure you have remembered your existing settings.

Reset PLC is the equivalent of fully powering down the PLC and restarting. This is required when changing printer type.

The screensaver saves power and prevents screen burn, this screen saver displays after 10 minutes of inactivity or can be disabled.

If you are using a printer you will want to set the RTC to your time-zone and this can be subsequently changed at any time.

The printer type is defaulted to Zebra, if you are using the Epson thermal printer, use the <> button to switch to Epson and then reset PLC with the printer powered and connected.

Commissioning

4.3 Print Mode

In print mode, set your target by pressing anywhere within the red square. This will prompt an onscreen keypad where you can enter your desired target. Your previous target will be highlighted and will be erased as you start typing your new length.

Along the bottom of the screen you have four buttons and two indicators. The home button takes you back to the home screen where you can then go through to the settings pages, this does not pause any functions of the counter. The print button sends a command to the printer to print a ticket/label, while print & reset does the same but also resets the current count ready for a new job. This does not reset the batch if you have this enabled, this can be reset by pressing reset all (pin protected) or with a digital input (see wiring on page 8). Lastly, reset current will reset your current count.

The two indicators will turn either green or red depending on the state of the target and endzone. In the screenshot below the target is grey since no target has been set. Once the end zone is reached, this will turn to red to indicate that the relays have changed states, and then once the target is reached, this will turn red and the endzone will return to green to indicate that the target has changed states but the endzone has returned to its original state.

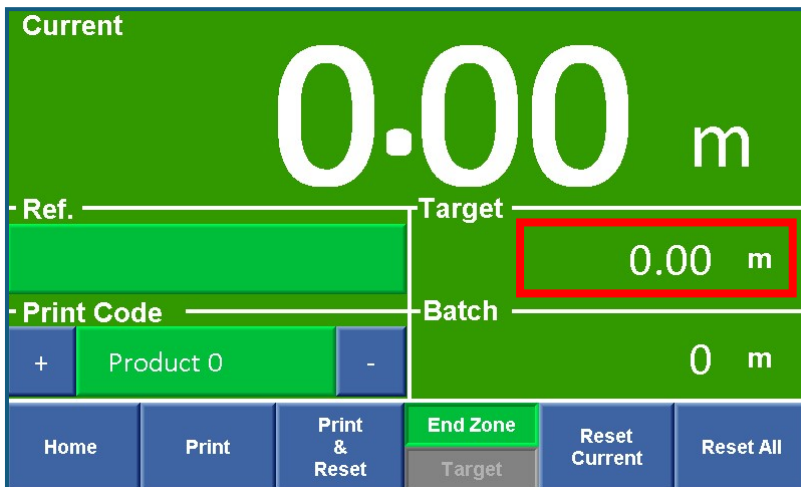

Setting of the print references will continue on the next page.

Commissioning

4.3 Print Mode

The print program has the facility to print two custom references. The first reference is intended to be changed frequently and rarely the same, where the second reference is intended to be semi-regular and called upon using the + and - buttons. To set the first reference, simply press anywhere within the ref box to prompt an alphanumeric keyboard.

For the product code, click the second box to be taken to a setup page.

On this page, cycle between the available references using the + and - buttons.

To set, press anywhere in the blank box underneath to prompt the alphanumeric keyboard and set your desired reference.

To confirm this, press enter and then if you are satisfied, 'Overwrite Current Code' to set this in the place of the above reference.

Continue this process for each product code you want to set.

Example Prints:

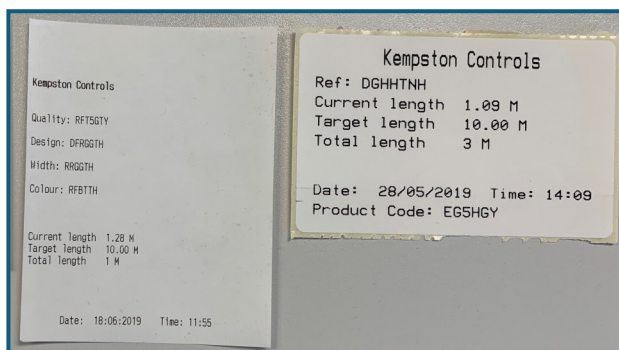

Commissioning

4.4 Standard Mode

In standard mode, set your target by pressing anywhere within the red square. This will prompt an onscreen keypad where you can enter your desired target. The previous target will be highlighted and clear as you enter your new length.

In this mode you have four buttons and two indicators.

The home button takes you back to the home screen where you can then go through the settings pages. This does not pause any functions of the counter.

Reset current will reset your current count, reset all will reset your current count as well as batch. This button is pin protected with the supervisors pin.

The units button will switch the counter from measuring in meters to measuring in feet or vice versa. This will reset the current count and so should not be done mid run.

The two indicators will turn either green or red depending on the state of the target and endzone. In the screenshot below the target is grey since no target has been set. Once the end zone is reached, this will turn to red to indicate that the relays have changed states, and then once the target is reached, the target indicator will turn red and the endzone will return to green to indicate that the target has changed states and the endzone has returned to its original state.

When your target is reached, the entire screen will also change to from green to red.

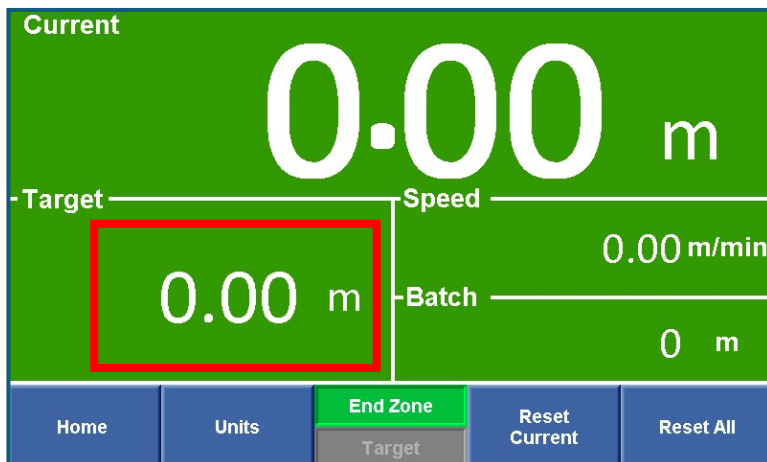

CONTACT US

UK, Europe, Asia, America, Africa:

Kempston Controls (A Division of Midland Automation Ltd)

Shirley Road, Rushden, NN10 6BZ, United Kingdom

Telephone: +44 (0) 1933 411 411

Email: sales@kempstoncontrols.co.uk

Middle East:

Kempston Controls LLC (A Division of Midland Automation Ltd)

PO Box: 60998, Umm Ramool, Dubai, UAE

Telephone: +971 (0) 4 298 7111

Email: sales@kempstoncontrols.ae