

# Installation Instructions

Original Instructions



**Allen-Bradley**  
by ROCKWELL AUTOMATION



## 440G-EZ Interlocking Safety Switch

Catalog Numbers 440G-EZS21STL05J, 440G-EZS21STL05H



**ATTENTION:** Read this document and the documents that are listed in [Additional Resources on page 4](#) about installation, configuration, and operation of this equipment before you install, configure, operate, or maintain this product. Users are required to familiarize themselves with installation and wiring instructions, and requirements of all applicable codes, laws, and standards. Only suitably trained personnel must perform activities including installation, adjustments, commissioning, use, assembly, disassembly, and maintenance in accordance with applicable code of practice. If this equipment is used in a manner that the manufacturer does not specify, the protection that is provided by the equipment may be impaired.

### Summary of Changes

This publication contains the following new or updated information. This list includes substantive updates only and is not intended to reflect all changes.

Topic	Page
Updated <a href="#">Figure 3</a> table.	2
Replaced <a href="#">Table 2</a> .	3
Added IP69K to enclosure ingress rating in Specifications table.	3

### Installation

Installation of the 440G-EZ safety switch must be in accordance with the following steps and stated specifications and implemented by suitably competent personnel. The unit is not to be used as a mechanical stop. Guard stops and guides must be mounted.

Adherence to the recommended maintenance instructions forms part of the warranty.



**ATTENTION:** The presence of spare actuators can compromise the integrity of the safety systems. Personal injury or death, property damage, or economic loss can result. Appropriate management controls, working procedures, and alternative protective measures should be introduced to control their use and availability.



**WARNING:** Do not defeat, tamper, remove, or bypass this unit. Severe injury to personnel could result. This device must be provided with a 24V DC PELV or SELV power supply that conforms to the requirements of 414-3 of IEC 60364-4-41 where provisions have been taken to confirm that, even if an internal fault is present, the voltage at the outgoing terminals cannot exceed 60V DC. Improper selection or installation of the devices affects the integrity of the safety systems.

### Intended Use

The 440G electromagnetic switch is suitable for monitoring the position of guard doors. It has a magnetic locking device for process protection only.



**ATTENTION:** Locking force is not monitored. Locking force is not a safety-related function.

### Mount Multiple Safety Switches

**IMPORTANT** When several safety switches are mounted, the minimum distance between the individual systems must be followed to avoid mutual interference.

Figure 1 - Spacing Requirement [mm (in.)]

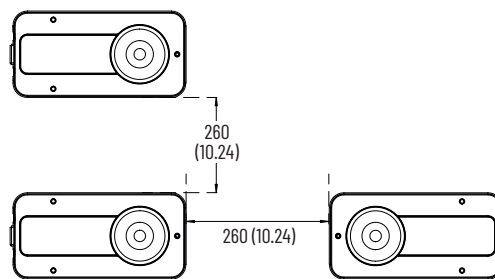

### Mounting

The sensor can be mounted in the following ways:

- Surface mount – The sensor is mounted on the fixed part of the protective device (for example, door frame).
- Flush mount – The sensor is mounted in the fixed part of the protective device (for example, door frame). There must be a suitable recess in the mounting surface. The thickness of the mounting surface must be between 1.5...3 mm (0.06...0.12 in.)

For recess dimensions for flush mounting, see [Figure 4 on page 4](#).

**IMPORTANT** Install the safety switch horizontally to help increase protection against manipulation.

## Mount the Sensor

1. Unscrew the fixing screw (hexagon socket, 2 mm [0.08 in.]) and remove the cover plate.

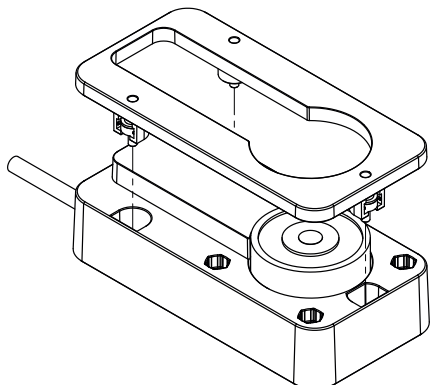

2. Mount the sensor on the fixed part of the protective device with 4 x M4 screws and secure it with four nuts.
  - For surface mount: mount the sensor on the fixed part of the protective device. The screws can be set in the front or the back.

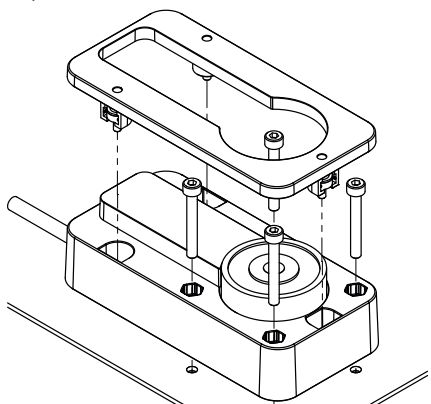

Tightening torque:  
1 N·m (8.9 lb·in)

- For flush mount: mount the sensor in the fixed part of the protective device.

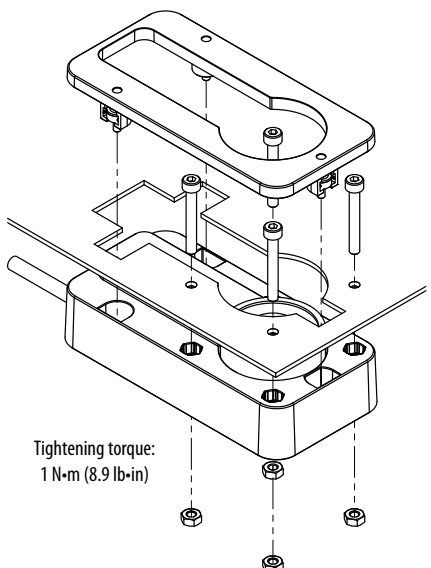

Tightening torque:  
1 N·m (8.9 lb·in)

3. Set cover plate on the sensor.
4. Tighten the fixing screws to 1 N·m (8.9 lb·in).

## Mount the Actuator

1. Align the actuator to the mounted sensor.
2. Mount the actuator on the moving part of the protective device (for example, door) with 4 x M4 screws. Tightening torque: 1 N·m (8.9 lb·in). Use disposable screws if possible.
  - Maximum angle between sensor and actuator when protective device is closed: 3°

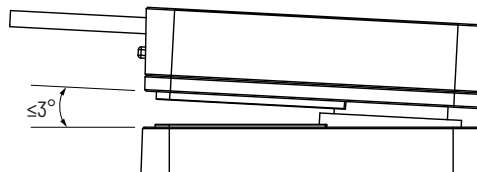

3. Cover drill holes of the actuator with protective caps.

## Wiring

Figure 2 - Device Connection Pin Assignment (Male Connector, M12, 5-pin, A-coded)

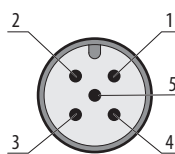

Pin	Wire Color <sup>(1)</sup>	Designation	Description
1	Brown	+24V DC	Safety switch voltage supply
2	White	OSSD 1	Safety output
3	Blue	0V	0V DC voltage supply
4	Black	OSSD 2	Safety output
5	Gray	Magnet	Magnet activation 24V DC

(1) Applies to the extension cables recommended as accessories.

**IMPORTANT** Pay attention to tightness of the plug connector.

Figure 3 - Device Connection Pin Assignment (Male Connector, M12, 8-pin, A-coded)

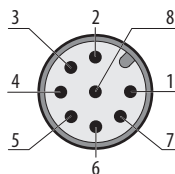

Pin	Wire Color <sup>(1)</sup>	Designation	Description
1	White	Aux	Application diagnostic output (not safe)
2	Brown	+24V DC	Safety switch voltage supply
3	Green	Magnet	Magnet activation 24V DC
4	Yellow	OSSD IN2	Safety input <sup>(2)</sup>
5	Gray	OSSD 1	Safety output
6	Pink	OSSD 2	Safety output
7	Blue	0V	0V DC voltage supply
8	Red	OSSD IN1	Safety input <sup>(2)</sup>

(1) Applies to the extension cables recommended as accessories.

(2) When used as an individual safety switch or as the first safety switch in a cascade apply 24V DC.

**IMPORTANT** Pay attention to tightness of the plug connector.

## Status Indicators

The switch has two status indicators:

**Table 1 - Status Indicator States**

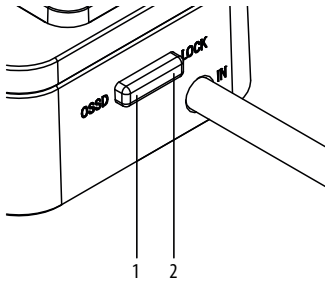

Item	Name	Color	Description
1	OSSD	Green/Red	<ul style="list-style-type: none"> <li>Green when the OSSD pair is in the ON state.</li> <li>Red when the OSSD pair is in the OFF state. <sup>(1)</sup></li> </ul>
2	LOCK	Yellow	Turns ON when the magnet is supplied with voltage.

(1) When a load is applied to the application diagnostic output that is too high, the red OSSD status indicator remains continuously ON. The actual switching behavior of the safety switch is not affected.

**Table 2 - Switch Status During Normal Operation**

Pins	Door/Guard Status	OSSD Inputs <sup>(1)</sup>	OSSD Indicator	AUX Status	OSSD Outputs
8-pin	Open	On or Off	Red	Off	Off
	Closed	On	Green	On <sup>(2)</sup>	On <sup>(2)</sup>
	Open	Off	Red	Off	Off
	Closed	Off	Red	Off	Off
5-pin	Open	—	Red	—	Off
	Closed	—	Green	—	On <sup>(2)</sup>

(1) OSSD input only available for use with 8-pin version.  
 (2) The AUX output and OSSD outputs are OFF if the device is in a fault state.

## Maintenance

Frequency	Description
Every week	<ul style="list-style-type: none"> <li>Ensure the alignment of the actuator to the switch and the correct operation of the switching circuit.</li> <li>Check for signs of abuse or interference.</li> <li>Inspect the switch casing and actuator for damage and replace if needed.</li> </ul>
At least every 6 months	<ul style="list-style-type: none"> <li>Isolate all power.</li> <li>Remove the lid and end cover.</li> <li>Inspect all terminals for tightness.</li> <li>Clean out any accumulation of fine dirt.</li> <li>Check for any sign of wear or damage, for instance, actuator wear, cam assembly wear, contact oxidization and replace if needed.</li> <li>Replace cover and tighten screws to specified settings.</li> <li>Reinstate the power and check for correct operation.</li> <li>Reapply tamper evident varnish or similar compound for mountings.</li> </ul>

## Repair

If there is any malfunction or damage, make no attempts at repair. Replace before machine operation is allowed.

**IMPORTANT** Do not dismantle the unit.

## Specifications

Attribute	440G-EZS2ISTL05J, 440G-EZS2ISTL05H
Functional Safety Data (Guard door sensing)	<ul style="list-style-type: none"> <li>PFHd= <math>1.5 \times 10^{-8}</math> at 40 °C (104 °F) and 1000 m (3280.8 ft) above sea level</li> <li>Mission time/PTI: 20 years</li> </ul>
<b>Operating Characteristics</b>	
Safe switch on distance	4 mm (0.16 in.)
Typical switch on distance	15 mm (0.59 in.)
Safe switch off distance	45 mm (1.77 in.)
Holding force	500 N
Retaining force	25 N
Maximum actuation frequency	0.5 Hz
Alignment tolerance for locking device	<ul style="list-style-type: none"> <li>Vertical: 5 mm (0.2 in.)</li> <li>Horizontal: 5 mm (0.2 in.)</li> </ul>
Aperture angle	3°
Offset tolerance	5 mm (0.2 in.)
Rated voltage	24V DC
Insulation voltage U <sub>i</sub>	32V
Rated impulse withstand voltage U <sub>imp</sub>	1.5 kV
Supply voltage when an individual safety switch is connected	24V DC (19.2...28.8 V DC) Class 2 supply
Supply voltage U <sub>V</sub> when a cascade is connected	<ul style="list-style-type: none"> <li>Sensor: 24V DC (22.8...28.8 V DC) Class 2 supply</li> <li>Magnet: 24V DC (21.6...28.8 V DC) Class 2 supply</li> </ul>
Power consumption	<ul style="list-style-type: none"> <li>Locking active: 350 mA</li> <li>Locking deactivated: 50 mA</li> </ul>
Switching frequency	≤0.5 Hz
Type of output	OSSD
Maximum Output current	≤100 mA
Diagnostic output	≤25 mA, short-circuit protected
Cable capacitance	400 nF (for OUT A and OUT B)
Response time	50 ms
Enable time	100 ms
Risk time	100 ms
Power up delay	2.5 s
Muting time when supply voltage is interrupted	4 ms
<b>Environmental</b>	
Operating temperature	-20...+55 °C (-4...+131 °F)
Storage temperature	-25...+70 °C (-13...+158 °F)
Relative humidity	50% at 70 °C (158 °F) (IEC 60947-5-2)
Enclosure ingress rating	IP67, IP69K
EMC	IEC EMC: EN IEC 61326-3-1, EN IEC 60947-5-2, EN IEC 60947-5-3
Vibration resistance	1 mm/10...55 Hz (IEC 60068-2-6)
Shock resistance	30 g, 11 ms (IEC 60068-2-27)
<b>Outputs</b>	
Safety outputs	2 x OSSDs, 2 x PNP, max 100 mA, short-circuit protected and overload-proof
Auxiliary output	25 mA max, short-circuit protected (resistive load)
Switching voltage	<ul style="list-style-type: none"> <li>ON State: 19.2...28.8 V DC</li> <li>OFF State: 0...2 V DC</li> </ul>
Switching current	<ul style="list-style-type: none"> <li>ON State: ≤100 mA</li> <li>OFF State: ≤500 μA</li> </ul>
Test pulse duration	300 μs
<b>Weight</b>	
Sensor	510 g (18 oz)
Actuator	210 g (7.4 oz)
<b>Material</b>	
Sensor housing	Anodized aluminum
Actuator housing	Fiberglass-reinforced PVC
Anchor plate	Nickel-plated steel

## Approximate Dimensions

Figure 4 - Flush Mounting [mm (in.)]

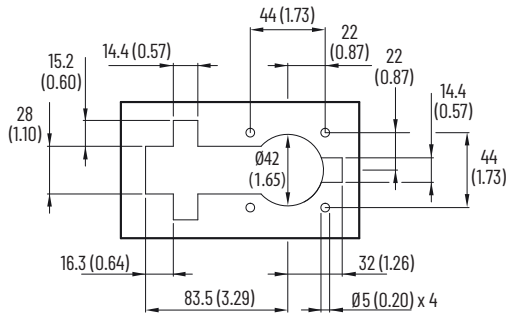

Figure 5 - Actuator [mm (in.)]

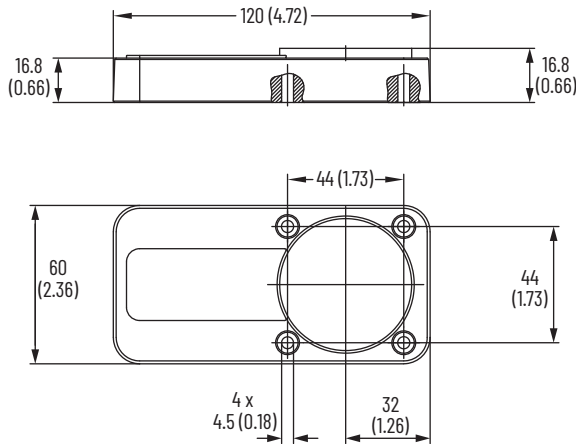
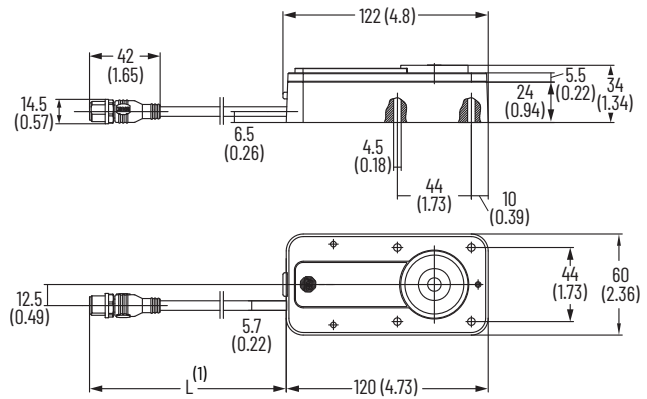

Figure 6 - Sensor [mm (in.)]



(1)  $L = 150 \pm 2$  mm (5.91 ± 0.79 in.)

## Additional Resources

These documents contain additional information concerning related products from Rockwell Automation.

Resource	Description
440G-EZ Interlocking Safety Switch User Manual, publication <a href="#">440G-UM003</a>	Provides information that is needed during the lifecycle of the 440G-EZ safety switch.
Industrial Automation Wiring and Grounding Guidelines, publication <a href="#">1770-4.1</a>	Provides general guidelines for installing a Rockwell Automation industrial system.
Product Certifications website: <a href="#">rok.auto/certifications</a>	Provides declarations of conformity, certificates, and other certification details.

You can view or download publications at [rok.auto/literature](#).

## Waste Electrical and Electronic Equipment (WEEE)







At the end of life, this equipment should be collected separately from any unsorted municipal waste.

Rockwell Automation maintains current product environmental compliance information on its website at [rok.auto/pec](#).

Your comments help us serve your documentation needs better. If you have any suggestions on how to improve our content, complete the form at [rok.auto/docfeedback](#).

For technical support, visit [rok.auto/support](#).

Rockwell Otomasyon Ticaret A.Ş. Kar Plaza İş Merkezi E Blok Kat:6 34752, İçerenköy, İstanbul, Tel: +90 (216) 5698400 EEE Yönetmeliğine Uygundur

Connect with us.    

[rockwellautomation.com](#)

expanding **human possibility**<sup>™</sup>

AMERICAS: Rockwell Automation, 1201 South Second Street, Milwaukee, WI 53204-2496 USA, Tel: (1) 414.382.2000, Fax: (1) 414.382.4444

EUROPE/MIDDLE EAST/AFRICA: Rockwell Automation NV, Pegasus Park, De Kleetlaan 12a, 1831 Diegem, Belgium, Tel: (32) 2 663 0600, Fax: (32) 2 663 0640

ASIA PACIFIC: Rockwell Automation, Level 14, Core F, Cyberport 3, 100 Cyberport Road, Hong Kong, Tel: (852) 2887 4788, Fax: (852) 2508 1846

Allen-Bradley, expanding human possibility, Guardmaster, and Rockwell Automation are trademarks of Rockwell Automation, Inc. Trademarks not belonging to Rockwell Automation are property of their respective companies.

Publication 440G-IN019C-EN-P - November 2020 | Supersedes Publication 440G-IN019B-EN-P- June 2020  
Copyright © 2020 Rockwell Automation, Inc. All rights reserved. Printed in the U.S.A.

10005248682 Ver 02  
8025119/1963/2020-11-03