

E1 Plus Electronic Overload Relays

Catalog Number Explanation/Product Selection

193 – EE C B
a b c d

2

a

Bulletin Number	
Code	Description
193	IEC Three-Phase
193S	IEC Single-Phase
592	NEMA Three-Phase
592S	NEMA Single-Phase

b

Type	
Code	Description
ED1*	Fixed Trip Class 10
EE	Selectable Trip Class

* Bulletin 193 overload relays only

c

Adjustment Range [A]			
Three-Phase		Single-Phase	
Code	Description	Code	Description
A	0.1...0.5	P	1.0...5.0
B	0.2...1.0	R	3.2...16
C	1.0...5.0	S	5.4...27
D	3.2...16	T	9...45
E	5.4...27	U	18...90
F	9...45	V	60...120
G	18...90	—	—
H	30...150	—	—
J	40...200	—	—
K	60...300	—	—
L	100...500	—	—
M	120...600	—	—
N	160...800	—	—

d

Bulletin 100 Contactor Size	
Code	Description
B	C09...C23
D	C30...C43
E	C60...C85, C60...C97
F	D95...D180, D115...D180
G	D210...D420
H	D630...D860
Bulletin 500 NEMA Contactor Size	
Code	Description
T	Size 00
C	Size 0...2
D	Size 3
Panel/DIN Rail Mount	
Code	Description
P	Integrated panel mount and pass-through wiring
Z	Panel mount with external current transformers

Product Selection

Bulletin 193-ED – Three-Phase Devices

- Fixed Trip Class 10
- Manual reset
- Screw-type control terminals

Mounts to Contactor	Adjustment Range [A]	Cat. No.
100-C09...100-C23	0.1...0.5	193-ED1AB
	0.2...1.0	193-ED1BB
	1.0...5.0	193-ED1CB
	3.2...16	193-ED1DB
	5.4...27	193-ED1EB
100-C30...100-C43	5.4...27	193-ED1ED
	9...45	193-ED1FD
	1.0...5.0	193-ED1CP
Integrated panel/DIN Rail mount and pass-thru wiring	3.2...16	193-ED1DP
	5.4...27	193-ED1EP

Bulletin 193-EE – Three-Phase Devices

- Selectable Trip Class (10, 15, 20, 30)
- Selectable manual/auto-manual reset
- Screw-type control terminals

Mounts to Contactor	Adjustment Range [A]	Cat. No.
100-C09...100-C23	0.1...0.5	193-EEAB
	0.2...1.0	193-EEBB
	1.0...5.0	193-EECB
	3.2...16	193-EEDB
	5.4...27	193-EEEB
100-C30...100-C43	5.4...27	193-EEED
	9...45	193-EEFD
100-C60...100-C97	18...90	193-EEGE
	60...120	193-EEVE
100-D95...100-D180	18...90	* 193-EEGF
	30...150	* 193-EEHF
	40...200	* 193-EEJF
	60...120	* 193-EEVF
100-D210...100-D420	40...200	* 193-EEJG
	60...300	* 193-EEKG
	100...500	* 193-EELG
100-D630...100-D860	120...600	* 193-EEMH
	160...800	* 193-EENH
Integrated panel/DIN Rail mount and pass-thru wiring	1.0...5.0	193-EECP
	3.2...16	193-EEDP
	5.4...27	193-EEEP

Package Quantity = 1

* Does not include terminal lugs. See page 2-212.



IEC Overload Relays & Modular Protection System

Product Overview

Overload Relays

Bulletin	193-ED	193-EE	193-EC1	193-EC2/EC3	193-EC5	193-EC4
Type	E1 Plus Electronic Overload Relay	E1 Plus Electronic Overload Relay	E3 Electronic Overload Relay	E3 Plus Electronic Overload Relay		E3 Plus Current Monitoring Relay
Rated Current (Range)	0.1...45 A	0.1...800 A	0.4...5000 A			
NEMA Operating Voltage, Nominal	—	600V	600V			
IEC Operating Voltage, Nominal	690V	690/1000V	690/1000V			
Overload Type	Electronic Overload	Electronic Overload	Microprocessor-Based			
Trip Class (Fixed)	10	—	—			
Trip Class (Adjustable)	—	10, 15, 20, 30	5...30		—	
Ambient Temperature Compensated	✓	✓	✓		—	
Reset Type	Manual Only	Automatic and Manual	Automatic and Manual			
Adjustment Range	5:1	5:1	5:1			
Phase Loss	3 s	3 s	Adjustable Delay			—
Ground (Earth) Fault	—	Optional	—	Sensitive	Sensitive	Sensitive
Overcurrent (Jam) Detection	—	Optional	✓	✓	✓	—
Stall Detection	—	—	✓	✓	✓	—
Underload Detection	—	—	✓	✓	✓	—
Current Imbalance	—	—	✓	✓	✓	—
PTC Thermistor Monitoring	—	Optional	—	✓	—	—
Warning Settings	—	—	✓	✓	✓	✓
N.C. Trip Contact	✓	✓	✓	✓	✓	✓
N.O. Alarm Contact	✓	✓	—	—	—	—
No. of Outputs	—	—	1	2	2	2
No. of Inputs	—	—	2	4	6	4
ODVA (DeviceNet) Conformance	—	Optional	✓	✓	✓	✓
Variable Frequency Drive (VFD) Compatible	—	—	✓	✓	✓	✓
Product Selection	Page 2-208	Page 2-208	Page 2-222	Page 2-222	Page 2-222	Page 2-222

2

Overload Relays & Modular Protection System

Bulletin	193-K	193-T1	825-P
Type	Bimetallic Overload Relay		Modular Protection System
Rated Current (Range)	0.1...12.5 A	0.1...90 A	0.5...5000 A
Operating Voltage, Nominal	600V		120...240V AC/DC, 24...48V DC
Overload Type	Bimetallic		Microprocessor based
Trip Class (Fixed)	10	10	—
Ambient Temperature Compensated	✓	✓	✓
Reset Type	Automatic and Manual	Automatic and Manual	Automatic and Manual
Adjustment Range	1.5:1	1.5:1	—
Phase Loss	Normal Sensing	Normal Sensing	Adjustable delay
N.C. Trip Contact	✓	✓	✓
N.O. Alarm Contact	✓	✓	✓
Variable Frequency Drive (VFD) Compatible	✓	✓	✓
Product Selection	Page 2-246	Page 2-249	Page 2-260

E1 Plus Electronic Overload Relays

Product Overview

2



E1 Plus Solid-State Overload Relays

193-ED/EE versions offer:

- Self-powered
- Phase loss protection
- Wide adjustment range (5:1)
- Over-molded power connections
- 1 N.O. and 1 N.C. isolated auxiliary contacts (B600 Rated)
- Low energy consumption (150 mW)
- Ambient temperature compensation
- Visible trip indication

193-ED version offers:

- 0.1...45 A current range
- Fixed Trip Class 10
- Manual reset

193-EE version offers:

- 0.1...800 A current range
- Selectable Trip Class (10, 15, 20, or 30)
- Selectable manual/auto-manual reset
- Single- and three-phase devices

Table of Contents

Product Selection 2-210
 Accessories..... 2-212
 Specifications..... 2-215
 Approximate Dimensions..... 2-219

Standards Compliance

IEC/EN 60947-4-1
 IEC/EN 60947-5-1
 CSA 22.2 No. 14
 UL 508

Certifications

CE
 cULus Listed
 C-Tick
 CCC

Your order must include 1) the Cat. No. of overload relay selected, and 2) if required, Cat. No. of any accessories.

Product Overview

Accurate, Reliable Performance

Current measurement-based protection

While electromechanical overload relays pass motor current through heating elements to provide an indirect simulation of motor heating, the E1 Plus Overload Relay directly measures motor current. Current measurement-based overload protection more accurately models a motor's thermal condition. Furthermore, ambient temperature does not impact the performance of current measurement-based designs over the specified temperature operating range.

Electronic design

Thermal modeling is performed electronically with precision solid-state components, where at the heart of the E1 Plus Overload Relay is an application-specific integrated circuit (ASIC). The ASIC continually processes motor current data to accurately maintain the time-current status of the motor thermal capacity utilization value.

Thermal memory

A thermal memory circuit allows the E1 Plus Overload Relay to model the heating and cooling effects of motor on and off periods. This ensures accurate protection for both hot and cold motors.

Enhanced phase loss protection

A separate phase loss detection circuit incorporated into the E1 Plus Overload Relay allows it to respond quickly to phase loss conditions; typical reaction time is 3 seconds.

Easy to Select and Apply

Straightforward installation

The self-powered design means that the E1 Plus Overload Relay installs in the same manner as traditional overload relays. Device setup is accomplished by simply dialing the setting potentiometer to the motor FLA rating. The low energy consumption of the electronic design minimizes temperature rise issues inside control cabinets.

Wide adjustment range

A wide 5:1 adjustment range results in the need for half as many catalog numbers as the bimetallic alternative in order to cover the same current range. This helps to reduce inventory carrying costs and affords greater installation flexibility for dual voltage machines. Evenly spaced setting tick marks enhance the ease of installation setup.

Rugged Construction

Over-molded power connections

The unique line-side over-molded power connections make for a sturdy two-component starter assembly that is unmatched in the industry. The pre-formed power connections allow easy starter assembly — every time.

Current transformers

The current transformers are secured separately in the overload housing to ensure the greatest degree of resistance to shock and vibration conditions. Varnished laminations ensure consistent performance and provide additional protection against corrosion.

Latching relay

The robust design of the bi-polar latching relay provides reliable trip and reset performance for the most demanding of applications. The self-enclosed relay offers additional environmental protection for use in industrial applications.

Application Flexibility

Isolated Contacts

The isolated contact configuration allows the N.C. and N.O. contacts to be applied in circuits operating at different voltage levels and without polarity restrictions. The B600 contact rating affords application in circuits rated to 600V.

DIP switch settings

Bul. 193-EE devices offer DIP switch settings to select the trip class (10, 15, 20 or 30) and the reset mode (manual or automatic), making these devices extremely versatile.

Pass-Thru Option

The E1 Plus Pass-Thru consumes 48% less panel space compared to a standard E1 Plus mounted in a panel mount adapter. The design provides an integrated DIN Rail mount and panel mounting holes and is intended for the following applications: DIN Rail and Panel Mount Applications, Bulletin 100-K mini contactor, external current transformers, and for use with non Allen-Bradley Contactors. The E1 Plus Pass-Thru Electronic Overload Relay provides all of the same expandable protection & communication capabilities as a standard E1 Plus, and eliminates the need for a separate panel mount adapter, which saves money and valuable panel space.



Side-Mount Expansion Modules

Through the use of optional side-mount expansion modules, functionality of the E1 Plus overload relays can be cost effectively expanded and machine operation and protection enhanced. Direct mounting to the left side of the 193-EE and 592-EE E1 Plus overload relays means that only 18 mm is added to the overall product width. The side-mounted accessory modules electronically interface with the E1 Plus overload relay so that all control circuit connections are made at the E1 Plus overload relay terminals.

E1 Plus DeviceNet™ Communication Module

The Bul. 193-EDN DeviceNet Communication Side-Mount Module provides a cost-effective, seamless deployment of motor starters onto the Integrated Architecture™ as an accessory for the E1 Plus electronic overload relay. The DeviceNet module provides Integrated I/O (2 inputs and 1 output) providing local connection of motor starter-related I/O. The DeviceNet module offers expanded protective functions including overload warning, jam protection, and underload warning. The DeviceNet module also allows access to average motor current (percentage of FLA setting), percentage of thermal capacity usage, device status, trip & warning identification, and trip history which allows continual monitoring of motor performance.

E1 Plus Remote Reset Module

The Bul. 193-ERR Remote Reset Module is available for applications that require remote reset of the E1 Plus overload relays after a trip occurs.

E1 Plus Jam Protection Module with Remote Reset

The Bul. 193-EJM Jam Protection Module provides front-accessible DIP switches which offers flexibility to provide jam protection to match application requirements. Selections are available for enabling or disabling the jam protection function and remote reset operation. Jam trip level settings are available at 150%, 200%, 300%, and 400% of full load current setting. Trip delay settings of 1/2, 1, 2, and 4 seconds are available to minimize nuisance tripping in applications where intermittent short-duration overloading is permissible.

E1 Plus Ground Fault Module with Remote Reset

The Bul. 193-EGF Ground Fault Protection Module offers front-accessible DIP switches providing flexibility to configure ground fault protection to match application requirements. Selections are available for enabling or disabling the ground fault protection function and remote reset operation. Ground fault trip level settings are available in four ranges: 20...100 mA (resistive loads only, for motor loads consult your local Rockwell Automation sales office or Allen-Bradley distributor), 100...500 mA, 0.2...1 A, and 1...5 A. Within each range, the specific ground fault trip level can be set (20%, 35%, 50%, 65%, 80%, 90%, or 100% of the maximum ground fault setting). Trip delay is fixed at 50 ms ± 20 ms.

E1 Plus Ground Fault/Jam Module with Remote Reset

The Bul. 193-EGJ Ground Fault/Jam Protection Module offers front-accessible DIP switches to provide flexibility to configure ground fault and jam protection to match application requirements. The ground fault selections are the same as the Bul. 193-EGF Ground Fault Protection Module. In addition to ground fault, this module offers selectable fixed jam protection. The user can enable or disable jam protection from the DIP switches. The jam protection is fixed at 400% of the full load current setting with a 0.5 second trip delay.

E1 Plus PTC Module with Remote Reset

The Bul. 193-EPT PTC Side-Mount Module provides two terminals for the connection of positive temperature coefficient (PTC) thermistor sensors. PTC sensors are commonly embedded in the motor stator windings to monitor winding temperature. PTC sensors react to actual temperature, so enhanced motor protection can be provided to address conditions like obstructed cooling and high ambient temperature.

E1 Plus EtherNet/IP Module

The Bul. 193-ETN EtherNet/IP network communication module delivers seamless control and direct access to motor performance and diagnostic data on an Ethernet-based network. It supports I/O and explicit messaging for data access by a programmable automation controller, and contains predefined ControlLogix® style tags for direct software access. The integrated web and e-mail server contains a web server to allow users to read information and configure parameters via a web browser. The device also uses a simple mail transfer protocol (SMTP) server to send e-mail or text messages in the event of a warning or trip condition.

E1 Plus Profibus Module

The Bul. 193-EPRB PROFIBUS network communication module delivers direct access to motor performance and diagnostic data on a field bus based network in addition to seamless control. The PROFIBUS communication module supports both PROFIBUS DP-V0 and DP-V1. Protective functions include overload warning, jam protection, and underload warning. The PROFIBUS network communication module monitors the motor current by electronically interfacing to the E1 Plus overload relay's current-sensing circuit. As a result, the side-mount module is able to identify the cause of the trip and provides warnings for overload, underload, phase loss, and jam. The module continuously monitors the motor's performance for average motor current, thermal capacity usage, and device status, and also provides a trip history for the five previous trips. Integrated I/O provides convenient local termination of motor-related inputs and outputs, simplifying the control architecture.

Bulletin 193S-EE – Single-Phase Devices

- Selectable Trip Class (10, 15, 20, 30)
- Selectable manual/auto-manual reset
- Screw-type control terminals

Mounts to Contactor	Adjustment Range [A]	Cat. No.
100-C09...100-C23	1.0...5.0	193S-EEPB
	3.2...16	193S-EERB
	5.4...27	193S-EESB
100-C30...100-C43	9...45	193S-EETD
100-C60...100-C85	18...90	193S-EEUE
Integrated panel/DIN Rail mount and pass-thru wiring	1.0...5.0	193S-EEPP
	3.2...16	193S-EERP
	5.4...27	193S-EESP

Bulletin 193 Panel Mount Devices for use with External Current Transformers §*

- Selectable Trip Class (10, 15, 20, 30)
- Selectable manual/auto-manual reset

CT Ratio	Adjustment Range [A]	Cat. No.
150:5	30...150	193-EEHZ
200:5	40...200	193-EEJZ
300:5	60...300	193-EEKZ
400:5	80...400	193-EEWZ
500:5	100...500	193-EELZ
600:5	120...600	193-EEMZ
800:5	160...800	193-EENZ

* Current Transformers supplied by customer, refer to page 2-216 for proper current transformer selection.
 § Order panel adapter, **Cat. No. 193-EPB**, separately.











Side-Mount Expansion Modules*



Function	E1 Plus‡ (Cat. No. 193/592-EE_)	E1 Plus w/ Jam Module (Cat. No. 193-EJM)	E1 Plus w/ Ground Fault Module* (Cat. No. 193-EGF)	E1 Plus w/ Ground Fault/Jam Module* (Cat. No. 193-EGJ)	E1 Plus w/ PTC Module (Cat. No. 193-EPT)	E1 Plus w/ Remote Reset Module (Cat. No. 193-ERR)	E1 Plus w/ DeviceNet Module (Cat. No. 193-EDN)	E1 Plus w/ EtherNet/IP Module (Cat. No. 193-ETN)	E1 Plus w/ Profibus Module (Cat. No. 193-EPRB)
Manual/Automatic Reset	X	X	X	X	X	X	X	X	X
Selectable Trip Class	10	X	X	X	X	X	X	X	X
	15	X	X	X	X	X	X	X	X
	20	X	X	X	X	X	X	X	X
	30	X	X	X	X	X	X	X	X
Jam Protection	On or Off	—	X	—	X	—	—	X	X
	Trip Level	—	Adjustable 150/200/300/400%	—	Fixed @ 400%	—	—	Adjustable 150...600% FLA	Adjustable 150...600% FLA
	Trip Delay	—	Adjustable 0.5/1.0/2.0/4.0 s	—	Fixed @ 0.5 s	—	—	Adjustable 0.5...25 s	Adjustable 0.5...25 s
	Inhibit	—	Dynamic Inhibit‡	—	Dynamic Inhibit‡	—	—	Dynamic Inhibit‡	Dynamic Inhibit‡
Ground Fault Protection	Type	—	—	Core-Balanced Ground Fault Protection*	Core-Balanced Ground Fault Protection*	—	—	—	—
	On or Off	—	—	X	X	—	—	—	—
	Trip Level	—	—	Adjustable 20 mA...5 A❖	Adjustable 20 mA...5 A❖	—	—	—	—
	Trip Delay	—	—	Fixed @ 50 ms ± 20 ms	Fixed @ 50 ms ± 20 ms	—	—	—	—
	Inhibit	—	—	Dynamic Inhibit‡	Dynamic Inhibit‡	—	—	—	—
PTC Protection	PTC Overtemperature Trip	—	—	—	—	X	—	—	—
	PTC Open Circuit	—	—	—	—	X	—	—	—
	PTC Short Circuit	—	—	—	—	X	—	—	—
Remote Reset Capability	—	X	X	X	X	X	X	X	X
Fault Indication	—	—	X	X	X	—	X	X	X

‡ Dynamic Inhibit: Protective function is enabled after the motor current goes above 150% and then falls to below 125%.
 * Requires use of an external ground fault sensor, **Cat. No. 193-CBCT_**.
 ❖ From 20...100 mA for resistive loads only.

E1 Plus Electronic Overload Relays

Accessories

	Description	For Use With	Pkg. Quantity	Cat. No.
	DIN Rail/Panel Adapter For separate mounting – can be mounted to top-hat rail EN 50 022-35	193-ED1_B, 193-EE_B, 193S-EE_B, 193-EE_Z, 592-EE_T	1	193-EPB
		193-ED1_D, 193-EE_D, 193S-EE_D		193-EPD
		193-EE_E, 193S-EE_E		193-EPE
	Current Adjustment Shield Prevents inadvertent adjustment of the current setting. Must be ordered in multiples of package quantities.	193-ED (all) 193-EE (all) 592-EE (all)	10	193-BC8
	External Reset Adapter For enclosed, through-the-door reset applications. Use with external reset button.	193-ED (all) 193-EE_B, 193-EE_D, 193-EE_E 193-EE_Z	1	193-ERA
	External Reset Button for Enclosed Devices	193-E all	1	800FM-R611 (Button)
				800F-ATR08 (Rod)
	Terminal Lugs • Set of two • Protection class IP2X per IEC 60529 and DIN 40 050	100-D115, 100-D140, 100-D180, 100-D115E...D180E, 193-EC_F, 193-EE_F	2	100-DTB180
		100-D210...100-D420, 193-EC_G, 193-EF2C, 193-EE_G	2	100-DTB420
	Terminal Lugs, Copper Frame Set of three	100-D115E, 193-EC_F, 193-EE_F	3	100-DLE110
		100-D210...100-D420, 193-EC_G, 193-EE_G	3	100-DL180
		100-D210...100-D420, 193-EC_G, 193-EE_G	3	100-DL420
		100-D630, 100-D860, 193-EC_H, 193-EE_H	3	100-DL630
		100-D630, 100-D860, 193-EC_H, 193-EE_H	3	100-DL860
	Terminal Covers • Protection class IP20 per IEC 60529 and DIN 40 050 • For direct-on-line, reversing, two-speed, and wye-delta/star-delta assemblies	100-D115...100-D180, 193-EC_F, 193-EE_F	1	100-DTC180
		100-D210...100-D420, 193-EC_G, 193-EE_G	1	100-DTC420
		100-D630...100-D860, 193-EC_H, 193-EE_H	1	100-DTC860
	DeviceNet Configuration Terminal Used to interface with objects on a DeviceNet network. Includes 1 m communications cable (193-CB1).	193-EDN, 193-EC (all), 592-EC (all); 280/281/283/284 ArmorStart, 825-P	1	193-DNCT
	1 meter communication cable, color-coded bare leads	193-DNCT	1	193-CB1
	1 meter communication cable, microconnector (male)	193-DNCT	1	193-CM1
	Panel Mount Adapter/Door Mount Bezel Kit	193-DNCT	1	193-DNCT-BZ1

	Description	For Use With	Pkg. Quantity	Cat. No.
	E1 Plus DeviceNet and Protection Module Communicates motor diagnostic data via DeviceNet, includes additional I/O, and provides enhanced motor protection options.*	193-EE (all), 592-EE (all), 193S-EE (all), 592S-EE (all)	1	193-EDN
	E1 Plus EtherNet/IP and Protection Module Communicates motor diagnostic data via EtherNet/IP, includes additional I/O, and provides enhanced motor protection options.*	193-EE (all), 592-EE (all), 193S-EE (all), 592S-EE (all)	1	193-ETN
	E1 Plus PROFIBUS & Protection Module Communicates motor diagnostic data via PROFIBUS, includes additional I/O, and provides enhanced motor protection options.*	193-EE (all), 592-EE (all), 193S-EE (all), 592S-EE (all)	1	193-EPRB
	E1 Plus Jam Protection Module Provides Jam protection with adjustable trip level and trip delay setting. The module also provides an input to allow remote reset of a trip.*	193-EE (all), 592-EE (all), 193S-EE (all), 592S-EE (all)	1	193-EJM
	E1 Plus Ground Fault Module Provides adjustable 20 mA...5 A ground fault protection. The module also provides an input to allow remote reset of a trip.*	193-EE (all), 592-EE (all), 193S-EE (all), 592S-EE (all)	1	‡ 193-EGF
	E1 Plus Ground Fault/Jam Module Provides adjustable 20 mA...5 A ground fault and fixed jam protection. The module also provides an input to allow remote reset of a trip.*	193-EE (all), 592-EE (all), 193S-EE (all), 592S-EE (all)	1	‡ 193-EGJ
	E1 Plus PTC Module Provides terminals for connection up to six PTC thermistor sensors. Sensors react to actual temperature and therefore provide enhanced motor protection. Module also provides an input to allow remote reset of a trip.*	193-EE (all), 592-EE (all), 193S-EE (all), 592S-EE (all)	1	193-EPT
	E1 Plus Remote Reset Module Provides an input to allow remote reset of a trip.*	193-EE (all), 592-EE (all), 193S-EE (all), 592S-EE (all)	1	193-ERR
	E1 Plus Remote Indicator Display Displays the status of an E1 Plus from the front of a panel and features a reset button. Mounts in a standard 22 mm push button cutout.*	193-EGF, 193-EJM, 193-EGJ, 193-PTC, 193-ERR (Ser. B or later)	1	193-ERID
	Module Adjustment Cover Prevents inadvertent adjustment of setting. Must be ordered in multiples of package quantity.	193-EJM	25	193-EMC





* Only one module may be added.

‡ Requires use of an external ground fault sensor (Cat. No. 193-CBCT_).

E1 Plus Electronic Overload Relays

Accessories



2

	Description	Size	For Use With	Pkg. Quantity	Cat. No.
	Core Balanced Ground Fault Sensor <ul style="list-style-type: none"> Required when using either an E1 Plus Ground Fault Protection or Ground Fault/Jam Module Required for ground fault protection with the Cat. No. 193-EC3_ _ overload relay 	20 mm (0.79 in.)	100-C09...100-C37 NEMA size 00...2	1	193-CBCT1
		40 mm (1.57 in.)	100-C09...100-C85 NEMA size 00...3	1	193-CBCT2
		63 mm (2.5 in.)	100-C09...100-C85, 100-D95...100-D180 NEMA size 00...4	1	193-CBCT3
		82 mm (3.25 in.)	100-C09...100-C85, 100-D95...100-D420 NEMA size 00...5	1	193-CBCT4







	Description	For Use With	Cat. No.
	24V AC, 50/60 Hz	E1 Plus (Series C and later)	193-EMRJ
	110/120V AC, 50/60 Hz		193-EMRD
	220/240V AC, 50/60 Hz		193-EMRA
	24V DC		193-EMRZ24
	48V DC		193-EMRZ48
	115V DC		193-EMRZ01

Marking Systems

Uniform labeling materials for contactors, motor starting equipment, timing relays and circuit breakers

	Description	Pkg. Qty.*	Cat. No.
	Label Sheet 105 self-adhesive paper labels each, 6 x 17 mm	10	100-FMS
	Marking Tag Sheet 160 perforated paper labels each, 6 x 17 mm, to be used with a transparent cover	10	100-FMP
	Transparent Cover To be used with marking tag sheets	100	100-FMC
	Marking Tag Adapters To be used with marking tag: System 1492 W	100	100-FMA2

* Must be ordered in multiples of package quantities.

		Cat. No. 193-ED1_B, 193-EE_B, and 592-EE_T	Cat. No. 193-EE_D, and 592-EE_C	Cat. No. 193-EE_E, and 592-EE_D	Cat. No. 193-EE_F†	Cat. No. 193-EE_G	Cat. No. 193-EE_H
Main Circuits							
Rated Insulation Voltage (U _i)		690V AC			1000V AC		
Rated Impulse Strength (U _{imp})		6 kV AC			6 kV AC		
Rated Operating Voltage (U _o) IEC/UL		690V AC/600V AC			1000V AC/600V AC		
Rated Operating Frequency		50/60 Hz (sinusoidal)			50/60 Hz (sinusoidal)		
Terminal Cross-Sections	Terminal Type						
	Terminal Screws	M5		M8	Lug		
Flexible-Stranded with Ferrule	Single Conductor Torque	2.5...16 mm ² 2.5 N•m	2.5...16 mm ² 2.5 N•m	4...35 mm ² 24 N•m	—	—	—
	Two Conductor Torque	2.5...10 mm ² * 3.4 N•m	2.5...10 mm ² * 3.4 N•m	4...25 mm ² 4 N•m	—	—	—
Coarse-Stranded/Solid	Single Conductor Torque	2.5...25 mm ² 2.5 N•m	2.5...25 mm ² 2.5 N•m	4...50 mm ² 4 N•m	16...150 mm ² 28 N•m	—	—
	Two Conductor Torque	6...16 mm ² * 3.4 N•m	6...16 mm ² * 3.4 N•m	4...35 mm ² 4 N•m	—	25...185 mm ² 28 N•m	70...240 mm ² 45 N•m
	Four Conductor Torque	6...16 mm ² * 3.4 N•m	6...16 mm ² * 3.4 N•m	4...35 mm ² 4 N•m	—	—	70...240 mm ² 45 N•m
Stranded/Solid	Single Conductor Torque	14...6 AWG 22 lb•in	14...6 AWG 22 lb•in	12...1 AWG 35 lb•in	6...300 MCM 250 lb•in	—	—
	Two Conductor Torque	14...6 AWG* 30 lb•in	14...6 AWG* 30 lb•in	6...2 AWG 35 lb•in	—	4...350 MCM 250 lb•in	2/0...500 MCM 400 lb•in
	Four Conductor Torque	14...6 AWG* 30 lb•in	14...6 AWG* 30 lb•in	6...2 AWG 35 lb•in	—	—	2/0...500 MCM 400 lb•in
Poizidriv Screwdriver Size		2	2	—	—	—	—
Slotted Screwdriver (mm)		1 x 6	1 x 6	—	—	—	—
Hexagon Socket Size (mm)		—	—	4	8	8	8
Control Circuits							
Rated Insulation Voltage (U _i)		690V AC					
Rated Impulse Strength (U _{imp})		6 kV AC					
Rated Operating Voltage (U _o) IEC/UL		690V AC / 600V AC					
Rating Designation		B600					
Rated Operating Current I _e		N.O./N.C.					
AC-15	12...120V	3/2					
	220...240V	1.5/1.5					
	380...480V	0.75/0.75					
	500...600V	0.6/0.6					
Thermal Current I _{the}		5 A					
Contact Reliability		17V, 5 mA					
Screw Terminal Cross Sections	Terminal Screw	M3					
	Single Conductor Torque	0.5...2.5 mm ² 0.55 N•m					
Flexible-Stranded with Ferrule	Two Conductor Torque	0.25...1.5 mm ² 0.55 N•m			0.2...0.75 mm ² 0.55 N•m		
	Single Conductor Torque	0.5...4 mm ² 0.55 N•m					
Coarse-Stranded/Solid	Two Conductor Torque	0.2...2.5 mm ² 0.55 N•m			0.2...1.5 mm ² 0.55 N•m		
	Single Conductor Torque	24...10 AWG 5 lb•in					
Stranded/Solid	Two Conductor Torque	24...12 AWG 5 lb•in			22...16 AWG 5 lb•in		
	Screwdriver Size (mm)	#1 Pozidriv/0.6 x 3.5 slotted					
Cage Clamp Cross-Sections							
Flexible-Stranded with Ferrule		0.25...1 mm ²					
Coarse-Stranded/Solid		0.2...1.5 mm ²					
Stranded/Solid		24...14 AWG					

* For multiple conductor applications, the same style and size of wire must be used.
 † Cat. Nos. 193-EEGF and 193-EEVF follow Cat. No. 193-EE_E specifications.

E1 Plus Electronic Overload Relays

Specifications

3-Pole Terminal Blocks

Cat. No. 100-DTB180	Cat. No. 100-DTB420
(A) 6...1/0 AWG, 16...50 mm ² (B) 6 AWG...250 MCM, 16...120 mm ² 90...110 lb•in, 10...12 N•m	(2) 4 AWG...600 MCM, 25...240 mm ² 180...220 lb•in, 20...25 N•m

Terminal Lug Kits

Cat. No. 100-DLE110	Cat. No. 100-DL180	Cat. No. 100-DL420	Cat. No. 100-DL630	Cat. No. 100-DL860
Lug: 6...2/0 AWG, 16...70 mm ² 90...110 lb•in, 10...12 N•m Terminal: 13/32 in., 10 mm 150 lb•in, 17 N•m	Lug: 6 AWG...250 MCM, 16...120 mm ² 90...110 lb•in, 10...12 N•m Terminal: 1/2 in., 13 mm 275 lb•in, 16 N•m	Lug: 2 AWG...350 MCM, 375 lb•in, 42 N•m Terminal: 11/16 in., 17 mm 140 lb•in, 16 N•m	Lug: 2/0 AWG...500 MCM, 70...240 mm ² 400 lb•in, 45 N•m Terminal: 3/4 in., 19 mm 600 lb•in, 68 N•m	Lug: 2/0 AWG...500 MCM, 70...240 mm ² 400 lb•in, 45 N•m Terminal: 3/4 in., 19 mm 600 lb•in, 68 N•m

Environmental Ratings

Ambient Temperature	Storage Operating	-40...+85 °C (-40...+185 °F) -20...+60 °C (-4...+140 °F)
Humidity	Operating Damp Heat	5...95% Non-condensing per IEC 68-2-3 and IEC 68-2-30
Vibration (per IEC 68-2-6)		3 G
Shock (per IEC 68-2-27)		30 G
Max. Altitude		2000 m
Pollution Environment		Pollution Degree 3
Degree of Protection		IP20

Protection

Type of Relay	Ambient Compensated, Time Delay, Phase Loss Sensitive	
Nature of Relay	Solid-State	
Trip Rating	120% FLA	
Trip Class	Type ED	10
	Type EE	10, 15, 20, 30
Reset Mode	Type ED	Manual
	Type EE	Automatic or Manual

Electromagnetic Compatibility

Electrostatic Discharge Immunity	Test Level	8 kV Air Discharge, 6 kV Contact Discharge
	Performance Level	1 ‡*
RF Immunity	Test Level	10 V/m
	Performance Level	1 ‡*
Electrical Fast Transient/Burst Immunity	Test Level	4 kV
	Performance Level	1 ‡*
Surge Immunity	Test Level	2 kV (L-E), 1 kV (L-L)
	Performance Level	1 ‡*

‡ Performance Criteria 1 requires the device under test (DUT) to experience no degradation or loss of performance.

* Environment 2.

General

	Cat. No. 193-ED1_B, 193-EE_B	Cat. No. 193-EE_D	Cat. No. 193-EE_E
Standards	UL508, CSA C22.2 No. 14, NEMA ICS 2-1993 Part 4, EN 60947-4-1, EN 60947-5-1		
Certifications	CE, cULus, C-Tick, CCC		
Approximate Weights (unpackaged)	0.25 kg (0.55 lb)	0.25 kg (0.55 lb)	0.52 kg (1.06 lb)

External Current Transformers (for use with cat. nos. 193-EE_Z)

The user shall provide one current transformer (CT) for each motor phase, and shall connect the CT's secondary leads to the appropriate E1 Plus overload relay power terminals, as shown in current transformer's wiring diagrams. The CT shall have the appropriate ratio (refer to the product nameplate or product description). Additionally, the CT shall be selected to be capable of providing the required VA to the secondary load, which includes the E1 Plus overload relay burden at the rated secondary current and the wiring burden. Finally, the CT shall be rated for protective relaying to accommodate the high inrush currents associated with motor startup, and shall have an accuracy of $\pm 2\%$ over its normal operating range. Typical CT ratings include (Instrument Transformers, Inc. — Model #23 or equivalent):

ANSI (USA)	Class C5B0.1
CSA (Canada)	Class 10L5
IEC (Europe)	5 VA Class 5P10

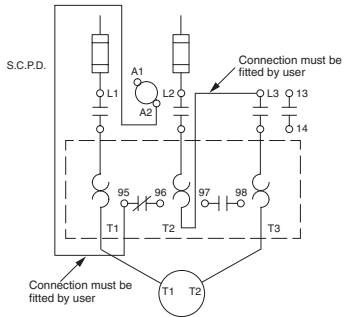

Typical Wiring for 1-Phase IEC Applications

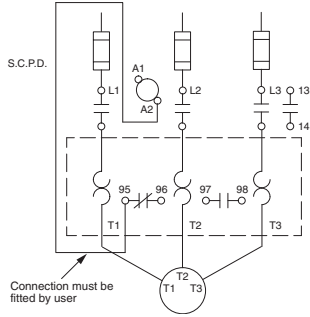

Typical Wiring for 3-Phase IEC Applications

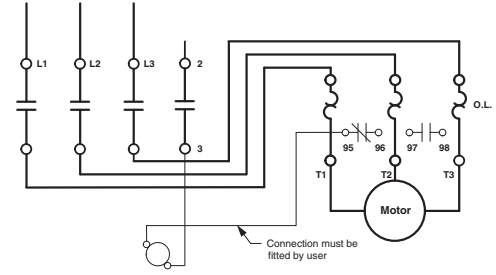

Typical Wiring for NEMA Applications

Trip Curves

Typical reset time for 193-EE devices set to automatic reset mode is 120 seconds.

Trip Class 10

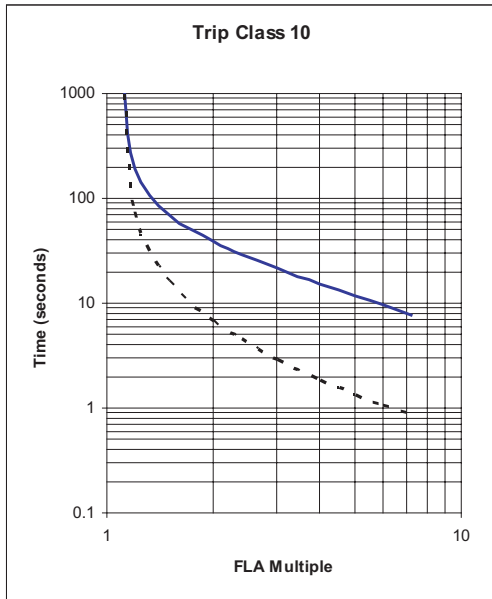

Trip Class 20

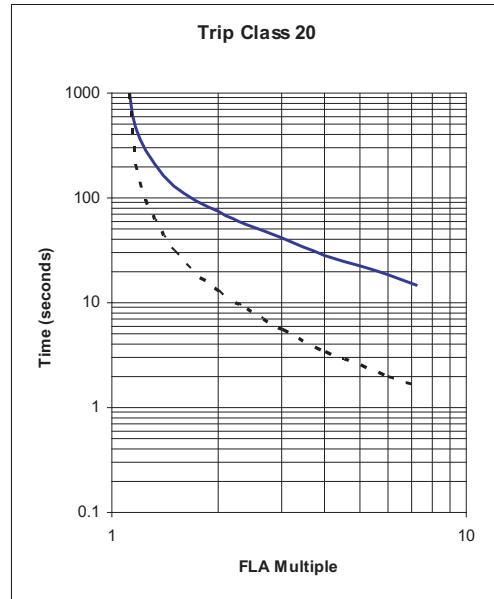

Trip Class 15

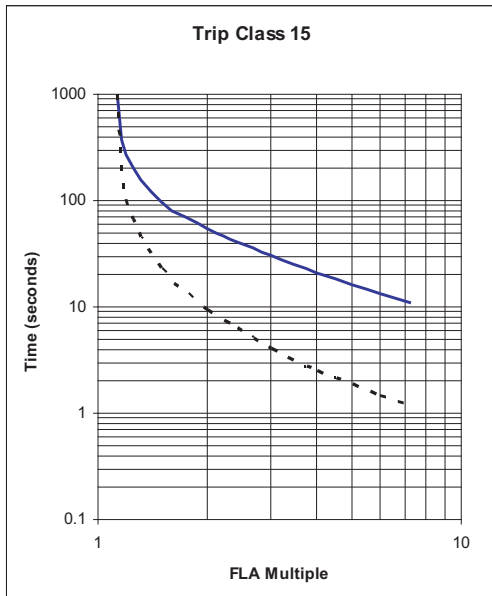

Trip Class 30

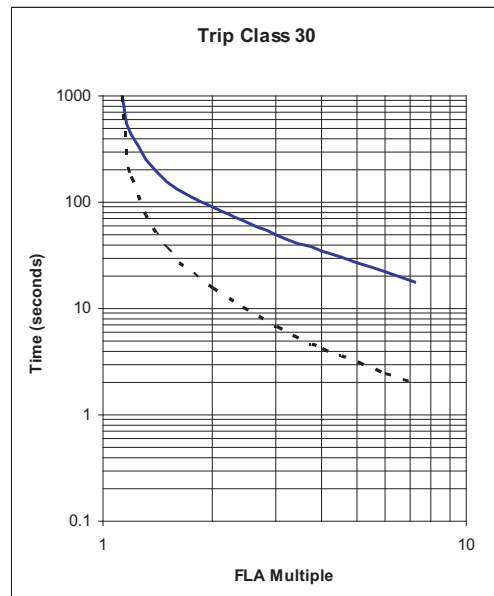

Trip Curve Legend: Cold Trip ———
 Hot Trip - - - - -



E1 Plus Electronic Overload Relays

Approximate Dimensions

Approximate dimensions are shown in millimeters (inches). Dimensions are not to be used for manufacturing purposes.

E1 Plus Pass-thru Style

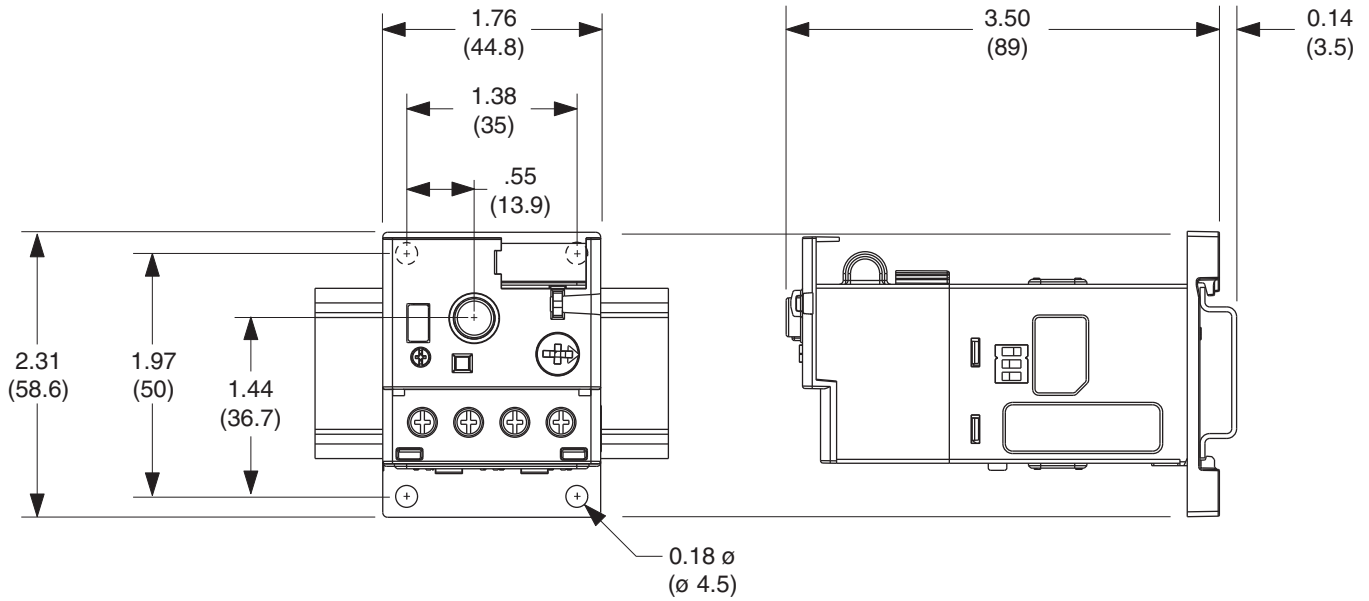

2

Approximate dimensions are shown in millimeters (inches). Dimensions are not to be used for manufacturing purposes.

Bulletin 100-C Contactor Mounted

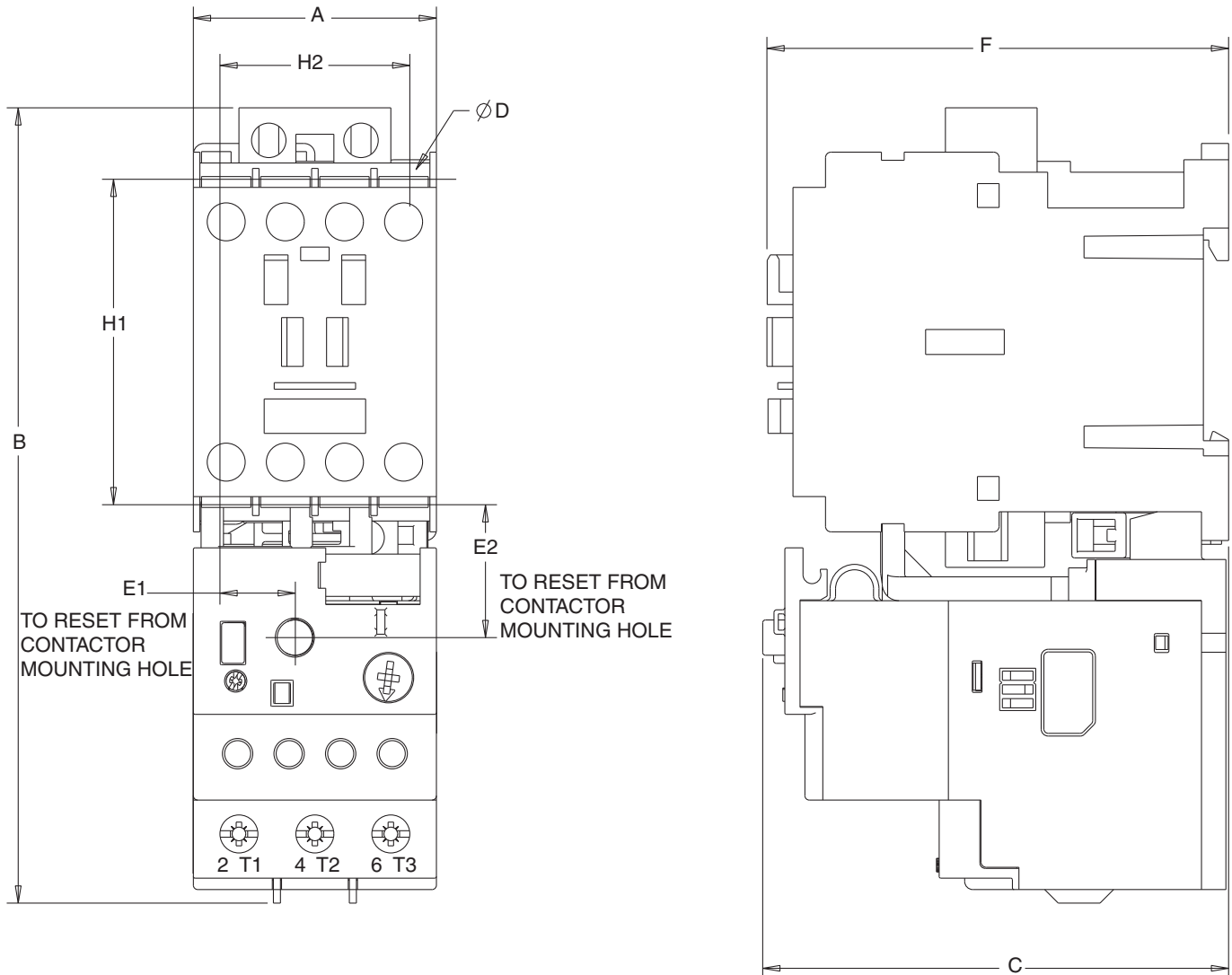

Overload Cat. No.	Contactor Cat. No.	Width A	Height B	Depth C	D	E1	E2	F	H1	H2
193-ED_B 193-EE_B 193R-EE_B 193S-EE_B	100-C09, -C12, -C16, -C23	45 (1-25/32)	146.6 (5-25/32)	85.2 (3-23/64)	4.5 (3/16)	13.9 (35/64)	24.5 (31/32)	86.5 (3-13/32)	60 (2-23/64)	35 (1-3/8)
193-EE_D 193R-EE_D 193S-EE_D	100-C30, -C37	45 (1-25/32)	146.6 (5-25/32)	101.2 (3-63/64)	4.5 (3/16)	13.9 (35/64)	24.5 (31/32)	104 (4-3/32)	60 (2-23/64)	35 (1-3/8)
193-EE_D 193R-EE_D 193S-EE_D	100-C43	54 (2-1/8)	146.6 (5-25/32)	101.2 (3-63/64)	4.5 (3/16)	18.9 (3/4)	24.5 (31/32)	104 (4-3/32)	60 (2-23/64)	45 (1-25/32)
193-EE_E 193R-EE_E 193S-EE_E	100-C60, -C72, -C85	72 (2-53/64)	192.3 (7-37/64)	120.4 (4-3/4)	5.4 (7/32)	23.8 (15/16)	29 (1-9/64)	125.5 (4-15/16)	100 (3-15/16)	55 (2-11/64)

E1 Plus Electronic Overload Relays

Approximate Dimensions

Approximate dimensions are shown in millimeters (inches). Dimensions are not to be used for manufacturing purposes.

Bulletin 100-D Contactor Mounted

2

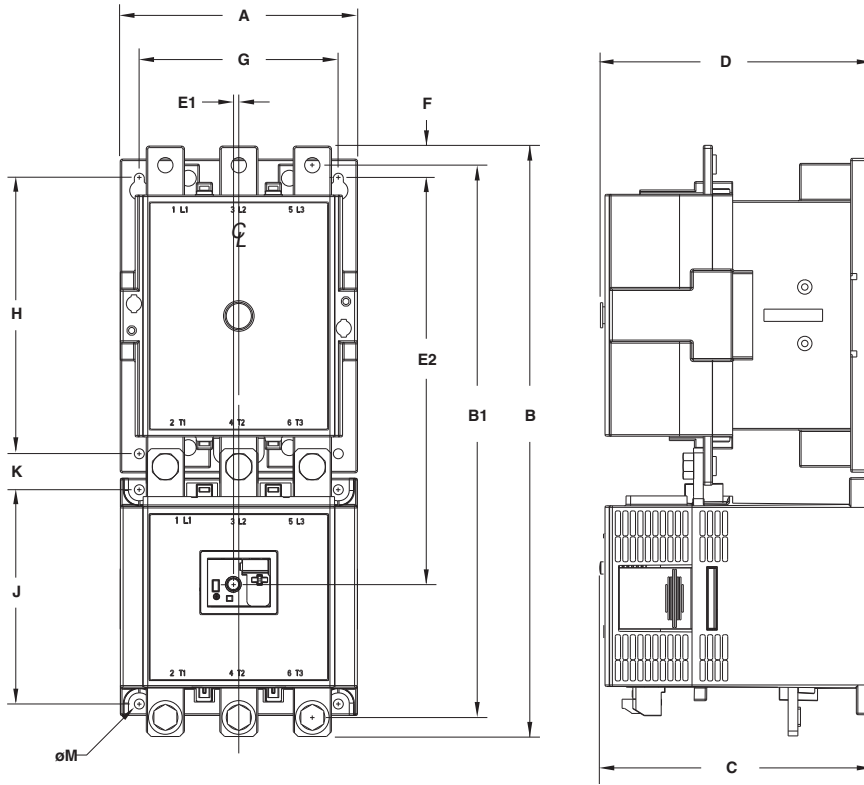

Overload Cat. No.	Contactor Cat. No.	Width A	Height B		Height B1	Depth C		E1	E2
			Without Terminal Covers	With Terminal Covers		(Reset)	D		
193-EE_F	100-D95, -D110	120 (4.72)	336.3 (13.24)	418 (16.46)	311.8 (12.27)	152.7 (6.01)	156 (6.14)	3.6 (0.14)	226.3 (8.91)
193-EE_F	100-D140, -D180	120 (4.72)	339.8 (13.38)	418 (16.46)	317.8 (12.51)	152.7 (6.01)	156 (6.14)	3.6 (0.14)	226.3 (8.91)
193-EE_G	100-D210, -D250, -D300, -D420	155 (6.10)	385.8 (15.19)	487.4 (19.19)	360.8 (14.2)	176.5 (6.95)	180 (7.09)	3.6 (0.14)	265.2 (10.44)
193-EE_H	100-D630, -D860	255 (10.04)	552 (21.73)	915 (36.02)	508 (20)	269.3 (10.6)	270.7 (10.66)	3.6 (0.14)	384.1 (15.12)

Overload Cat. No.	Contactor Cat. No.	F	G	H	J	K	øM
193-EE_F	100-D95, -D110	45 (1-25/32)	100 (3.94)	145 (5.71)	135 (5.31)	22.3 (0.88)	8 - 5.6 (8 - 0.22)
193-EE_F	100-D140, -D180	45 (1-25/32)	100 (3.94)	145 (5.71)	135 (5.31)	22.3 (0.88)	8 - 5.6 (8 - 0.22)
193-EE_G	100-D210, -D250, -D300, -D420	54 (2-1/8)	130 (5.12)	180 (7.09)	140 (5.51)	23.5 (0.93)	8 - 6.5 (8 - 0.26)
193-EE_H	100-D630, -D860	52.5 (2.07)	226 (8.90)	230 (9.06)	108 (4.25)	109 (4.29)	8 - 13 (8 - 0.51)



Approximate dimensions are shown in millimeters (inches). Dimensions are not to be used for manufacturing purposes.

Panel Adapter Mounted

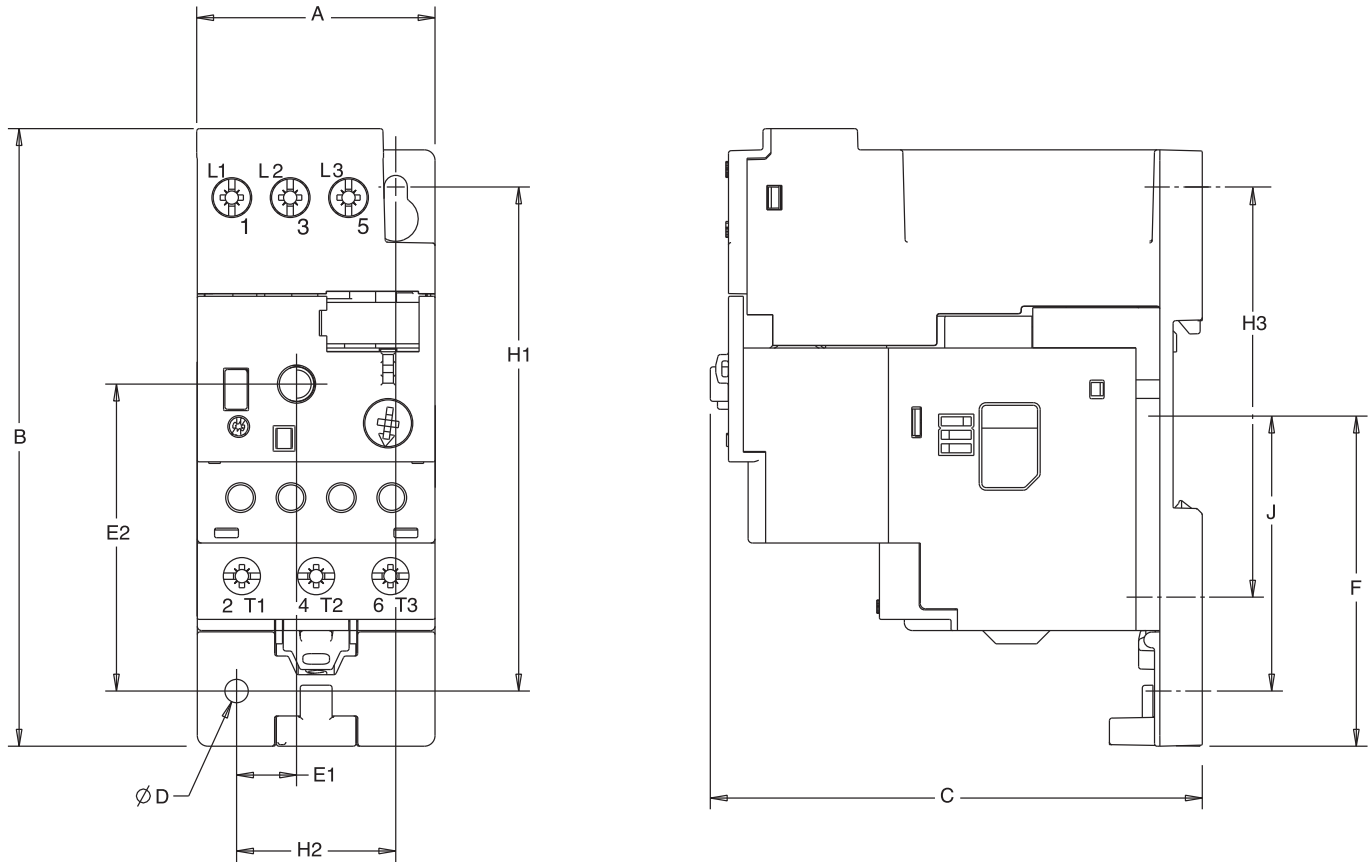

Panel Adapter Cat. No.	Overload Cat. No.	Width A	Height B	Depth C	D	E1	E2	F	H1	H2	H3	J
193-EPB	193-ED_B 193-EE_B 193R-EE_B 193S-EE_B	45 (1-25/32)	116.5 (4-19/16)	92.7 (3-21/32)	4.4 (11/64)	11.4 (0.45)	57.9 (2-9/32)	62.5 (2-15/32)	95 (3-3/4)	30 (1-3/16)	75 (2-31/32)	52.1 (2-3/64)
193-EPD	193-EE_D 193R-EE_D 193S-EE_D	45 (1-25/32)	112.4 (4-7/16)	108.7 (4-9/32)	4.4 (11/64)	11.4 (0.45)	57.9 (2-9/32)	62.5 (2-15/32)	95 (3-3/4)	30 (1-3/16)	75 (2-31/32)	52.1 (2-3/64)
193-EPE	193-EE_E 193R-EE_E 193S-EE_E	72 (2-53/64)	107.4 (4-15/64)	127 (5/32)	5.5 (5/32)	26.4 (1-1/32)	54.5 (2-9/64)	48.3 (1-29/32)	90 (3-23/64)	60 (2-23/64)	—	43.3 (1-45/64)

DIN Rail / Panel Adapter - Terminal Cross Sections

		Cat. No. 193-EPB *	Cat. No. 193-EPD *	Cat. No. 193-EPE
Flexible-Stranded with Ferrule	Single Conductor	1.0...4.0 mm ²	2.5...16 mm ²	4.0...35 mm ²
	Torque	1.8 N•m	2.3 N•m	4.0 N•m
	Two Conductor	1.0...4.0 mm ²	2.5...10 mm ²	4.0...25 mm ²
	Torque	1.8 N•m	2.3 N•m	4.0 N•m
Coarse-Stranded/Solid	Single Conductor	1.5...6.0 mm ²	2.5...25 mm ²	4.0...50 mm ²
	Torque	1.8 N•m	2.3 N•m	4.0 N•m
	Two Conductor	1.5...6.0 mm ²	2.5...16 mm ²	4.0...35 mm ²
	Torque	1.8 N•m	2.3 N•m	4.0 N•m
Stranded/Solid	Single Conductor	14...8 AWG	16...6 AWG	12...1 AWG
	Torque	16 lb•in	20 lb•in	35 lb•in
	Two Conductor	14...10 AWG	16...6 AWG	12...2 AWG
	Torque	16 lb•in	20 lb•in	35 lb•in

* For multiple conductor applications, the same size and style wire must be used.