

# PACSystems\* RX3i IC695PSD140E

GFK-2377F  
January 2016

## Multipurpose DC Power Supply, 40 Watts

PACSystems<sup>®</sup> RX3i Power Supply IC695PSD140 is a multipurpose 40-Watt supply that operates from an input voltage source in the range of 18 VDC to 30 VDC.

This power supply provides three outputs:

- +5.1 VDC output,
- +24 VDC relay output that can be used to power circuits on Output Relay modules.
- +3.3 VDC. This output is used internally by RX3i modules with IC695 catalog numbers.

Multipurpose Power Supply IC695PSD140 is suitable for use in load-sharing and redundancy applications. It must be installed in a PACSystems RX3i (IC695 catalog number) Universal Backplane. It can be used as the only power supply in the backplane, or combined with up to three additional Multipurpose Power Supplies.

### Caution

***This Power Supply cannot be used with RX3i IC695PSD040 or IC695PSA040 Power Supplies in redundant or increased capacity modes. Damage to equipment may result.***

## Load Sharing

When RX3i Multipurpose DC Power Supplies are combined into load-sharing applications, following the installation guidelines given in this datasheet, they must be wired to the same power source in such a way that they all can be powered up or powered down simultaneously. The On/Off front panel switch on each of the power supplies must be left in the On position.

### Caution

**In a load-sharing application, it is important to ensure that the load-sharing power supply modules' On/Off switches cannot be inadvertently used. The minimum number of power supplies needed to meet the system power requirements MUST have their switches always kept in the On position. Also, the load-sharing power supplies must be connected to the system power source through the same external switch. The system must be powered up and powered down only from the external switch. If individual power supplies are powered up or powered down using their On/Off switches or separate external switches, resulting in insufficient power capacity, equipment damage may result. It may be necessary to reload the PLC operating system to resume operation.**



\* Indicates a trademark of General Electric Company and/or its subsidiaries. All other trademarks are the property of their respective owners.

## LEDs

Four LEDs on the Power Supply indicate:

- Power (Green/Amber). When this LED is green, it indicates power is being supplied to the backplane. When this LED is amber, power is applied to the Power Supply but the Power Supply switch is off.
- P/S Fault (Red). When this LED is lit, it indicates the Power Supply has failed and is no longer supplying sufficient voltage to the backplane.
- Over Temperature (Amber). When this LED is lit, it indicates the Power Supply is near or exceeding its maximum operating temperature.
- Overload (Amber). When this LED is lit, it indicates the Power Supply is near or exceeding its maximum output capability on at least one of its outputs.

If the red P/S FAULT LED is lit, the Power Supply has failed and is no longer supplying sufficient voltage to the backplane .

The amber OVERTEMP and OVERLOAD LEDs light to warn of high temperature or high load conditions.

The CPU Fault Table shows a fault if any Overtemperature, Overload, or P/S Fault occurs.

## Wiring Terminals

Terminals for +24V and -24V power, ground, and MOV disconnect accept individual 14 to 22AWG wires.

## On/Off Switch

The ON/OFF switch is located behind the door on the front of the module. The switch controls the operation of the outputs of the supply. It does NOT interrupt line power. A projecting tab next to the switch helps prevent accidentally turning it on or off.

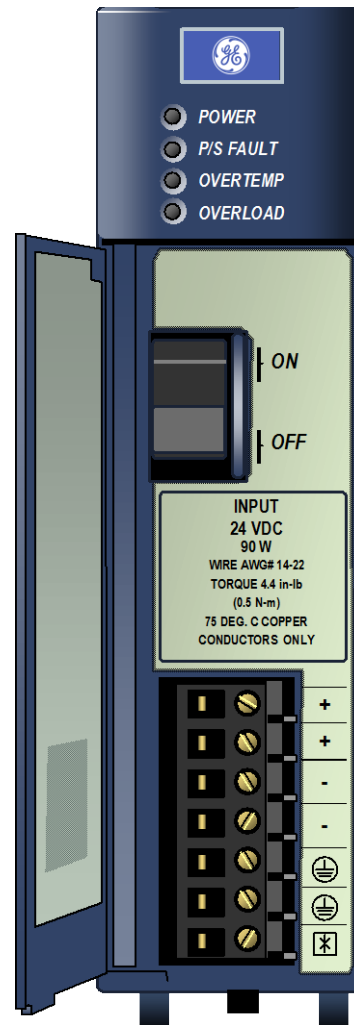

**Specifications: IC695PSD140**

<b>Nominal Rated Voltage</b>	24 VDC
<b>Input Voltage Range</b>	18 to 30 VDC
<b>Input Power</b>	60 Watts maximum at full load
<b>Inrush Current</b>	4 Amps, 100 milliseconds maximum †
<b>Output Power</b>	40 Watts maximum total of both outputs. 5.1 VDC = 30 Watts maximum 3.3 VDC = 30 Watts maximum Maximum output power depends on ambient temperature, as shown.
<b>Output Voltage</b>	5.1 VDC: 5.0 VDC to 5.25 VDC (5.1 VDC nominal) 3.3 VDC: 3.2 VDC to 3.465 VDC (3.3 VDC nominal)
<b>Output Current</b>	5.1 VDC: 0 to 6 Amps 3.3 VDC: 0 to 9 Amps
<b>Isolation</b>	None
<b>Ripple (all outputs)</b>	50 mV
<b>Noise (all outputs)</b>	50 mV
<b>Ride-through time</b>	10 ms This is the length of time the Power Supply maintains valid outputs if the power source is interrupted. If this Power Supply is used with IC694 and IC693 modules that have relay outputs, special precautions should be taken because dropouts in the source voltage will be seen by the module and could cause relay dropouts.
<b>Wiring Terminals</b>	Each terminal accepts one 14 AWG to 22 AWG wire.
<b>Terminal Current</b>	6 Amps
<b>Number of Daisy-Chained PSD140 Supplies</b>	Up to 4
<b>Number of PSD140 Supplies in Universal Backplane</b>	Up to 4
<b>Installation Environment</b>	For use in Pollution Degree 2 environments only

† The Inrush Current specification is given as a guide for sizing the external power source for the IC695PSD140. Peak inrush current may be higher for shorter durations.

**Overcurrent Protection**

The 5.1 VDC output is electronically limited to 7 Amps. The 3.3 VDC output is limited to 10 Amps. If an overload (including short circuits) occurs, it is sensed internally and the Power Supply shuts down. Because it is designed for redundancy applications, this Power Supply latches “OFF” in fault conditions and will not automatically try to restart. Input power must be cycled to clear a latched fault. However, if the Power Supply is used in a non-redundant application where automatic restarting is required, a jumper plug can be installed as shown below.

An internal non-repairable fusible link in the input line is provided as a backup. The Power Supply usually shuts down before the fusible link blows. The fusible link also protects against internal supply faults. The CPU Fault Table shows a fault if any Overtemperature, Overload, or P/S Fault occurs. There is no additional indication if the Power Supply fusible link blows.

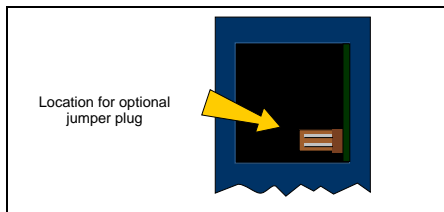

In a non-redundancy application, where automatic restarting may be appropriate, a shunt can be installed on back of the module as shown at left. The shunt must have 0.100 inch spacing on center and accommodate 0.25 inch pins. Example parts are Radio Shack DIP Programming Shunt #276-1512 and DIGI-Key #59000-ND. The module must be removed from the backplane to install the shunt.

## Thermal Deratings: PSD140

The maximum output power for Power Supply PSD140 depends on the ambient temperature, as shown below. Full output power is available up to at least 40°C (89.6°F).

### 5.1 Volt Fully-Loaded

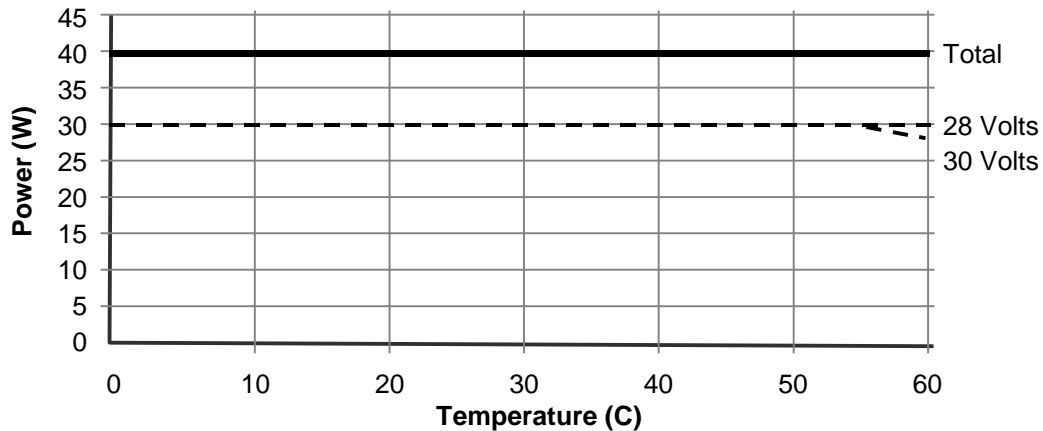

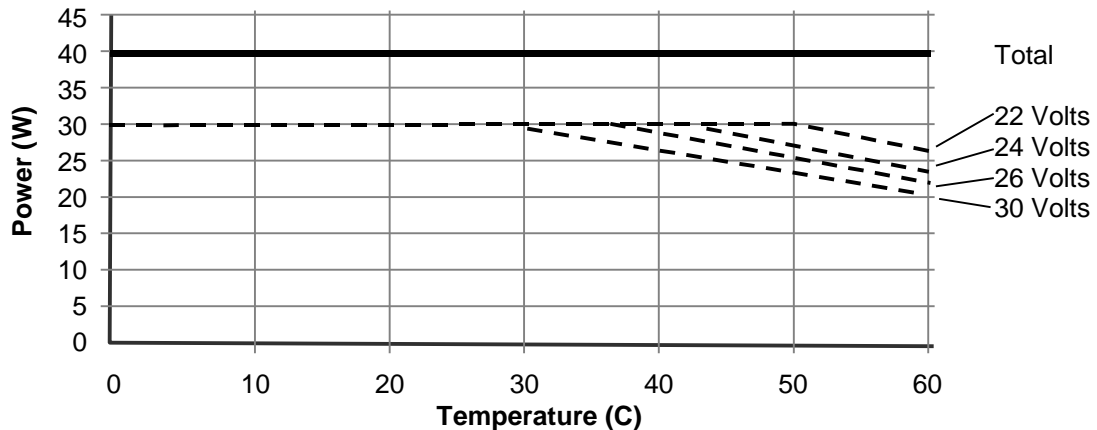

### 3.3 Volt Fully Loaded



## Installation in Hazardous Areas

The following information is for products bearing the UL marking for Hazardous Locations or ATEX marking for explosive atmospheres:

-  WARNING - EXPLOSION HAZARD - SUBSTITUTION OF COMPONENTS MAY IMPAIR SUITABILITY FOR CLASS I, DIVISION 2 OR ZONE 2;
  -  WARNING - EXPLOSION HAZARD - WHEN IN HAZARDOUS LOCATIONS, TURN OFF POWER BEFORE REPLACING OR WIRING MODULES; AND
  -  WARNING - EXPLOSION HAZARD - DO NOT CONNECT OR DISCONNECT EQUIPMENT UNLESS POWER HAS BEEN SWITCHED OFF OR THE AREA IS KNOWN TO BE NONHAZARDOUS.
- EQUIPMENT LABELED WITH REFERENCE TO CLASS I, GROUPS A, B, C & D, DIV. 2 OR ZONE 2 HAZARDOUS LOCATIONS IS SUITABLE FOR USE IN CLASS I, DIVISION 2, GROUPS A, B, C, D, ZONE 2, OR NON-HAZARDOUS LOCATIONS ONLY.

## Field Wiring: IC695PSD140

### Power Source and Ground Connections

The wires from the power source and ground connect to the terminals on the Power Supply as shown at right. Each terminal accepts one AWG 14 to AWG 22 wire.

When tightening the screw terminals, do not exceed the maximum torque limit of 0.5 N-m (4.4 inch-lbs). Use copper conductors rated 75 degree C minimum.

**Warning**

*If the same external DC power source is used to provide power to two or more power supplies in the system, connection polarity must be identical at each RX3i power supply. A resulting difference in potential can injure personnel or cause damage to equipment. Also, each backplane must be connected to a common system ground.*

### Input Overvoltage Protection

The bottom terminal is normally connected to frame ground with a user-installed jumper as shown at lower right. If overvoltage protection is not required or is supplied upstream, no jumper is required.

To Hi-pot test this supply, overvoltage protection must be disabled during the test by removing the jumper. Re-enable overvoltage protection after testing by reinstalling the jumper.

**Warning**

**This power supply is not isolated and is therefore not compatible with floating or positive grounded systems.**

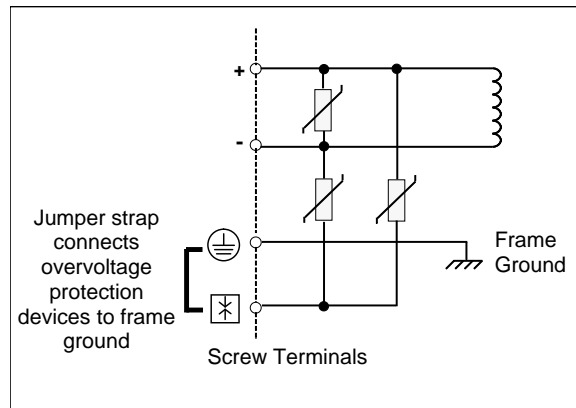
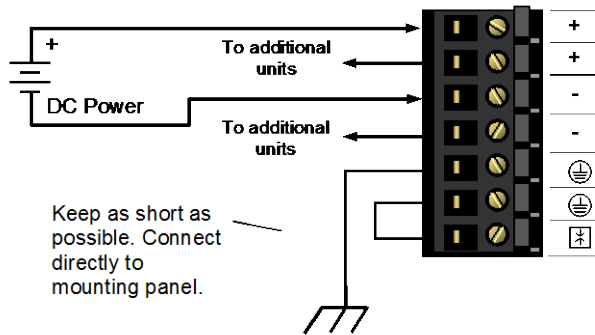

### Power Supply Field Wiring Terminals

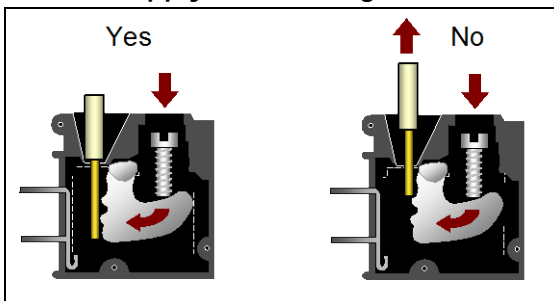

Each terminal accepts one AWG 14 to AWG 22 wire. The end of each wire should be stripped at least 9mm (3/8-inch). The terminal can accept a wire that is stripped up to 11 mm (0.433 in) while providing full seating of the insulator. The wire must be fully inserted as shown at left, so that the insulation meets the insulation stop position inside the terminal. Tightening the terminal screw pivots the clamp firmly against the stripped end of the wire, holding it in place. If the wire is not fully inserted as shown at right, tightening the terminal screw could push the wire upward so that it is not connected.

### Connections for Load Sharing

In load-sharing installations, additional Multipurpose Power Supplies above the minimum required for the system load may be wired to the same power source, or a different source.

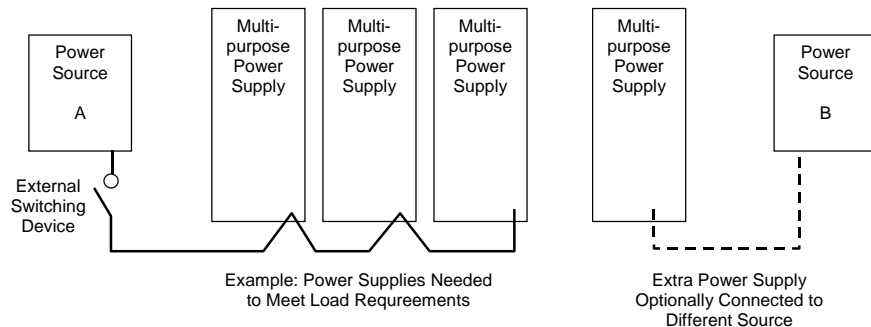

### Connections for Power Supply Redundancy

Power Supply redundancy can be provided by using one additional Multipurpose Power Supply above the minimum required for the system power load. In this type of installation, all Multipurpose Power Supplies contribute a share of the backplane power and run at a correspondingly reduced load. This results in longer life for the individual power supplies. In addition, should one power supply module fail, system operation is not interrupted. The front panel switch can be used to remove a redundant unit. Note that this type of system does not provide protection against loss of the input power source. If more than power supply is switched off, the remaining power supplies may become overloaded and shut down. An External switching device must be used to remove power from more than 1 power supply at a time in the Power Supply Redundancy mode.

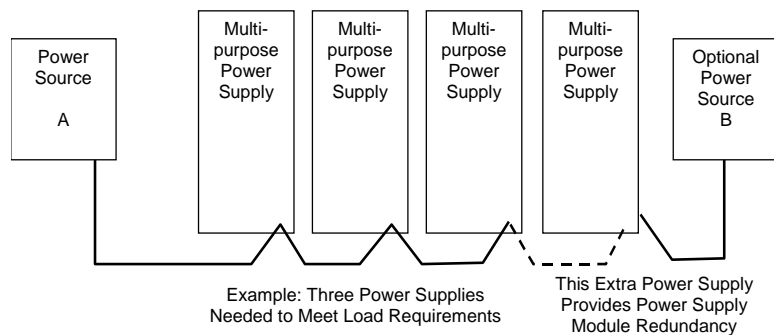

### **Power Source Redundancy**

If the overall power needs of the system can be met using either one or two Multipurpose Power Supplies, then power source redundancy can be provided. This requires using twice the minimum number of Multipurpose Power Supplies required to meet the system load requirements. In this type of system, half of the Multipurpose Power Supplies must be connected to one power source and the other half must be connected to a separate source. This arrangement provides all the advantage of a Basic Redundancy system, as described above, plus power source redundancy. The front panel switch may be used to remove an individual power supply as long as the minimum number of units remain powered up.

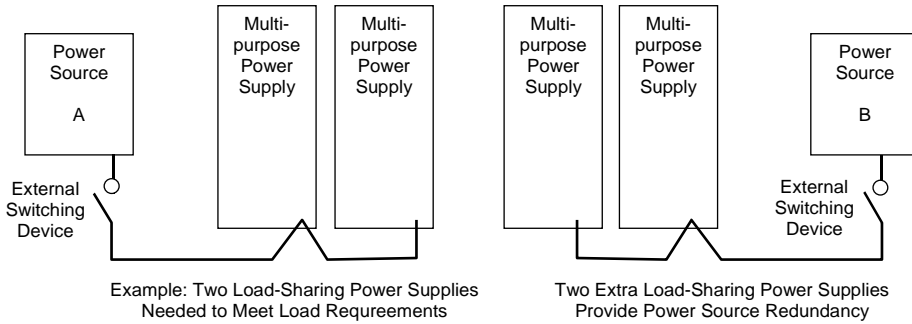

## Release History

<b>Version</b>	<b>Date</b>	<b>Comments</b>
IC695PSD140E	Jan 2016	Updated modules are RoHS converted product with applicable exemptions. No change in form-fit-functionality
IC695PSD140D	May 2013	Increases the margin of the 5V and 3.3V under voltage detectors to prevent PS faults during power-up.
IC695PSD140C	Sep. 2011	Resolves radiated susceptibility and surge issues in the RX3i PSD140 DC power supplies.
IC695PSD140B	May 2010	Resolves an issue with previous versions of this power supply occasionally failing to power up when installed in a 16-Slot Universal Backplane, IC695CHS016.
IC695PSD140A	Mar. 2005	Initial release.

## Important Product Information for This Release

### Compatibility

#### Output Relay Modules

When the following modules in an RX3i backplane are powered by Power Supply IC695PSD040:

IC693MDL930	IC694MDL930
IC693MDL931	IC694MDL931
IC693MDL940	IC694MDL940

and the 24Vdc input power to the power supply could experience a momentary loss of power, special precautions should be taken. A momentary loss of input power will cause a momentary loss of +24V relay power. This loss of +24Vrelay power may cause the module relays to momentarily drop out. Power dropouts of up to 10mS do not affect the 5 VDC and 3.3 VDC power outputs.

## Problems Resolved by This Product Revision

None



1-800-433-2682

1-434-978-5100

[www.ge-ip.com](http://www.ge-ip.com)