

FEATURES

- Excellent resistance to corrosive media (stainless steel barrel and rod)
- Mountings integrated in the front and MP4 cap in the rear cover for trunnion mounting
- Compact threaded mount for direct attachment of front or rear covers on machine
- Double acting cylinders with or without pneumatic cushioning

GENERAL

Detection	Equipped for magnetic position detectors
Fluid	Air or inert gas, filtered, lubricated or not
Operating pressure	[1 bar = 100 kPa]
single acting	2 to 10 bar
double acting	10 bar, max.
Ambient temperature	-10°C to +70°C
Optimal max. speed	≤ 1 m/s (for optimal service life)
Max. speed rate	2 m/s
Standards	ISO 6432



B

CONSTRUCTION

Barrel	Non-magnetic stainless steel
Rod	Stainless steel
Front and rear ends	Anodised light alloy (stainless steel: SSC option)
Cushioning seals	PUR (polyurethane)
Cushioning ^(a)	Pneumatic, adjustable from both sides with captive screw
Rod nut / neck nut	Galvanised steel
Piston	Light alloy POM (polyacetal) fitted with an annular permanent magnet
Piston seals	PUR (polyurethane)
Dismounting	Cannot be dismounted

Double acting ^(a) cushioning length
Ø 16 mm = 12,5 mm
Ø 20 mm = 17,5 mm
Ø 25 mm = 18 mm

^(a) CSH option

HOW TO ORDER

15-DIGIT PRODUCT CODE

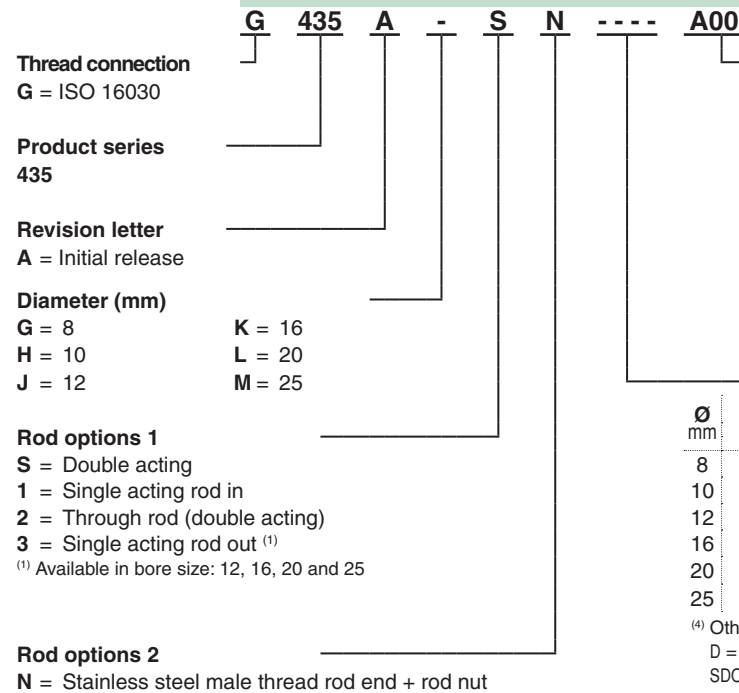

Options

- A00** = Not cushioned piston, prepared for magnetic detection
 - CSH** = Pneumatic cushioned piston, prepared for magnetic detection ⁽²⁾
 - SSC** = Not cushioned piston, prepared for magnetic detection, with stainless steel covers ⁽³⁾
 - AT1** = Not cushioned piston, prepared for magnetic detection, certified for ATEX 1/21 zones
 - AT2** = Not cushioned piston, prepared for magnetic detection, certified for ATEX 2/22 zones
- ⁽²⁾ Available in bore size: 16, 20 and 25 (double acting only)
⁽³⁾ Available in bore size: 12, 16, 20 and 25 (double acting only)

Recommended standard strokes (mm) ⁽²⁾

Ø mm	connect. Ø	connect.					max. stroke
		25	50	80	100	160	
8	M5	SD	SD	D	D	-	400
10	M5	SD	SD	D	D	-	400
12	M5	SDO	SDO	D	D	-	400
16	M5	SDO	SDO	D	D	-	400
20	G1/8	SDO	SDO	D	D	D	400
25	G1/8	SDO	SDO	D	D	D	900

⁽⁴⁾ Other strokes on request. / Min. stroke: 5 mm



D = Double acting only / SD = Single & Double acting
SDO = Single acting rod in + Single acting rod out + Double acting



POSITION DETECTORS

Magnetic position detectors must be ordered separately: "T" model (see page P291), reed switch or magneto-resistive type

INSTALLATION

- The cylinders can be mounted in any position without affecting operation
- Each cylinder is delivered with a neck nut and a rod nut
- Mountings: **catalogue number**

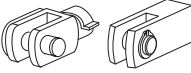
Ø (mm)						
	MF8		MS3			
	steel	st. steel	steel	st. steel	steel	st. steel
8 - 10	P493AG42A000A00	-	P493AG425000A00	-	P493AG42C000A00	-
12 - 16	P493AJ42A000A00	P493AJ42A200A00	P493AJ425000A00	P493AJ425200A00	P493AJ42C000A00	P493AJ42C200A00
20	P493AL42A000A00	P493AL42A200A00	P493AL425000A00	P493AL425200A00	P493AL42C000A00	P493AL42C200A00
25	P493AL42A000A00	P493AL42A200A00	P493AL425000A00	P493AL425200A00	P493AL42C000A00	P493AL42C200A00

Ø (mm)						
	AP2		AP6		MR3	
	steel	st. steel	steel	steel	st. steel	st. steel
8 - 10	P493AG431000A00	-	P493AG432000A00	P493AG42F000A00	-	-
12 - 16	P493AJ431000A00	P493AJ431200A00	P493AJ432000A00	P493AJ42F000A00	P493AJ42F200A00	P493AJ42F200A00
20	P493AL431000A00	P493AL431200A00	P493AL432000A00	P493AL42F000A00	P493AL42F200A00	P493AL42F200A00
25	P493A3131000A00	P493AM431200A00	P493A3132000A00	P493AL42F000A00	P493AL42F200A00	P493AL42F200A00

- Pipe connections G 1/8 have standard thread according to ISO 16030
- Installation/maintenance instructions are included with each cylinder

DIMENSIONS (mm), WEIGHT (kg)



SINGLE-ROD TYPE CYLINDER

Bare cylinder, single and double acting
Supplied with front cover nut
ISO 6432



THROUGH-ROD TYPE CYLINDER

Bare cylinder, double acting
Supplied with front cover nut
ISO 6432

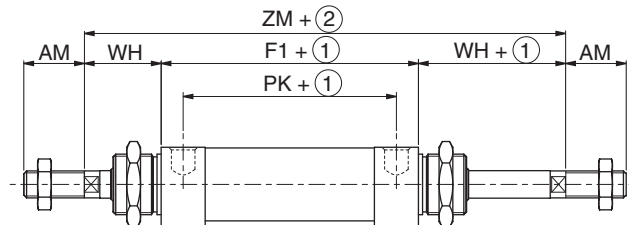
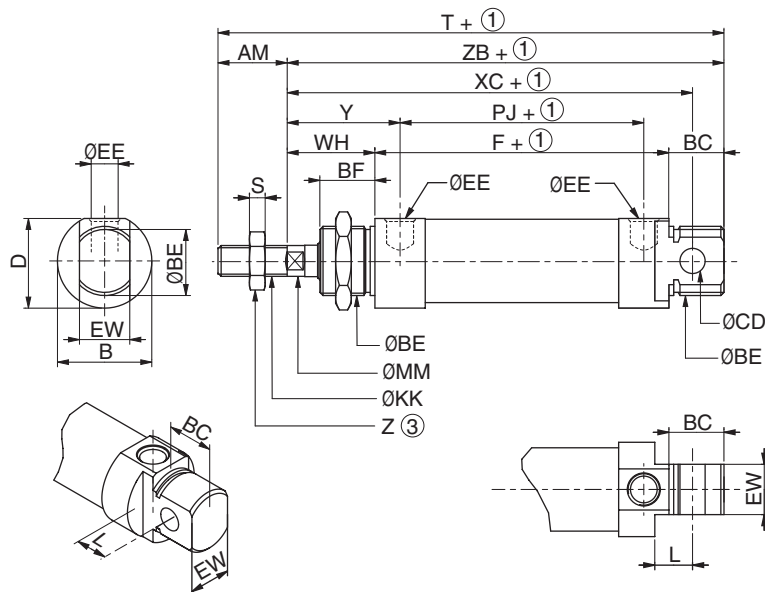

- ① Stroke
- ② Stroke x 2
- ③ Width across flats

Ø	AM	B	BC	ØBE	BF	ØCD	D	ØEE	EW	F	F1	ØKK	L	MM	PJ	PK	S	T	WH	XC	Y
8	12	16	12	M12x1,25	12	4 H 9	15	M5	8 d 13	46	-	M4x0,7	6	4	34	-	2	86	16	64	22
10	12	16	12	M12x1,25	12	4 H 9	15	M5	8 d 13	46	-	M4x0,7	6	4	34	-	2	86	16	64	22
12	16	19	14	M16x1,5	14	6 H 11	18	M5	12 d 11	48,5	48,5	M6x1	9	6	34,5	34,5	3	100,3	22	75	29
16	16	19	14	M16x1,5	14	6 H 11	18	M5	12 d 11	55	55	M6x1	9	6	41,5	41,5	3	107	22	82	28,5
20	20	27	17,5	M22x1,5	17,5	8 H 11	25,4	G 1/8	16 d 11	63,5	63,5	M8x1,25	12	8	47,3	47,3	4	125	24	95	32
25	22	30	17,5	M22x1,5	17,5	8 H 11	28,5	G 1/8	16 d 11	68,5	68,5	M10x1,25	12	10	52,5	52,5	5	136	28	104	36

Ø	Z	ZB	ZM	weight	
				(4)	(5)
8	7	74	-	0,030	0,020
10	7	74	-	0,030	0,040
12	10	84,5	82,5	0,070	0,090
16	10	91	99	0,100	0,100
20	13	105	111,5	0,170	0,160
25	17	114	124,5	0,200	0,200

(4) Cylinder weight at 0 mm stroke.
(5) Weight to be added per additional 100 mm length.

NOTE:
- Single and double acting cylinders Ø 8 to 25 mm have the same dimensions.
- The length of the single acting rod in version is twice the nominal stroke.
- The mountings are always delivered separately

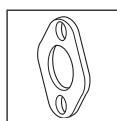

MOUNTING

Front or rear flange
MF8

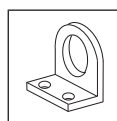
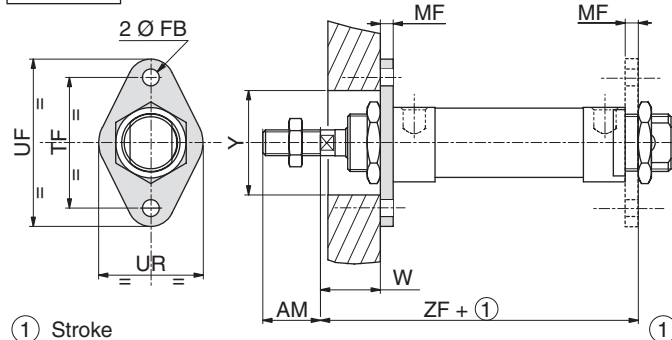

MOUNTING

High foot
Foot mounting are supplied in single units,
not in pairs
MS3

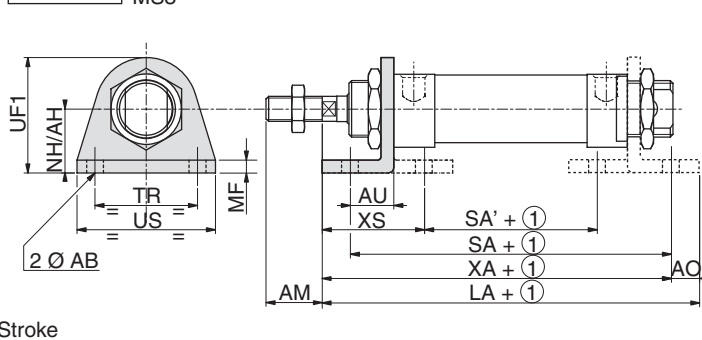

Ø (mm)	AM	ZF	MF	Y	W	ØFB	UF	TF	UR	weight
08	12	65	3	22	13	4,5	40	30	22	0,020
10	12	65	3	22	13	4,5	40	30	22	0,020
12	16	74,5	4	22	18	5,5	52	40	30	0,020
16	16	81,0	4	22	18	5,5	52	40	30	0,020
20	20	92,5	5	31	19	6,6	64	50	40	0,040
25	22	101,5	5	31	23	6,6	64	50	40	0,040

Ø (mm)	UF1	NH/AH	TR	US	MF	ØAB	AM	AU	XS	SA	SA'	XA	LA	AO	weight
08	26	16	25	35	3	4,5	12	11	24	68	30	73	78	5	0,030
10	26	16	25	35	3	4,5	12	11	24	68	30	73	78	5	0,030
12	32	20	32	42	4	5,5	16	14	32	76,5	28,5	84,5	90,5	6	0,050
16	32	20	32	42	4	5,5	16	14	32	83	35	91	97	6	0,050
20	45	25	40	54	5	6,6	20	17	36	97,5	39,5	104,5	113,5	9	0,100
25	45	25	40	54	5	6,6	22	17	40	102,5	44,5	113,5	122,5	9	0,100

01426GB-2013/R01
Availability, design and specifications are subject to change without notice. All rights reserved.

DIMENSIONS (mm), WEIGHT (kg)

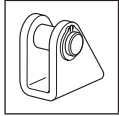

MOUNTING
Rear trunnion

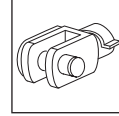

MOUNTING
Female rod clevis
ISO 8140
AP2

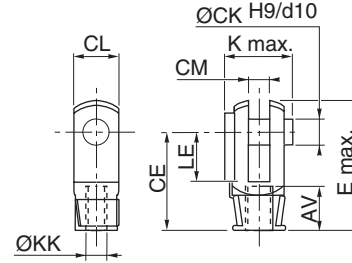
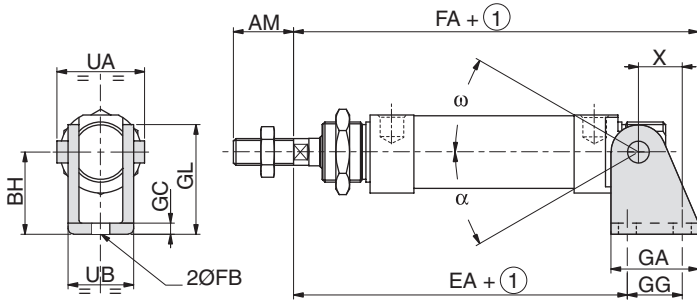

① Stroke

Ø (mm)	AM	BH	EA	FA	FB	GA	GC	GG	GL	UA	UB	X	α	ω	weight
8	12	24	62,7	79	4,5	20	2,5	12,5	29	18	13	11,2	7°	160°	0,020
10	12	24	62,7	79	4,5	20	2,5	12,5	29	18	13	11,2	7°	160°	0,020
12	16	27	72,5	93	5,5	25	3	16	34	25	18	13,5	50°	180°	0,050
16	16	27	79,5	100	5,5	25	3	16	34	25	18	13,5	47°	180°	0,050
20	20	30	91	117	6,6	32	4	20	40	32	24	16	8°	168°	0,080
25	20	30	100	126	6,6	32	4	20	40	32	24	16	8°	168°	0,080

Ø (mm)	Ø CK	CM	K	AV	LE	CE	CL	ØKK	E max.	weight
8	4	4 +0,4 +0,1	11	8	8	16	8	M4x0,7	22,5	0,010
10	4	4 +0,4 +0,1	11	8	8	16	8	M4x0,7	22,5	0,010
12	6	6 +0,4 +0,1	16,5	12	12	24	12	M6x1	33,5	0,020
16	6	6 +0,4 +0,1	16,5	12	12	24	12	M6x1	33,5	0,020
20	8	8 +0,5 +0,15	22	15	16	32	16	M8x1,25	45	0,050
25	10	10 +0,5 +0,15	26	20	20	40	20	M10x1,25	56	0,100

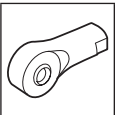

MOUNTING
Spherical rod end
ISO 8139
AP6

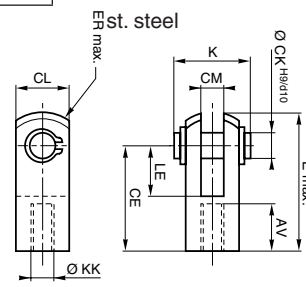
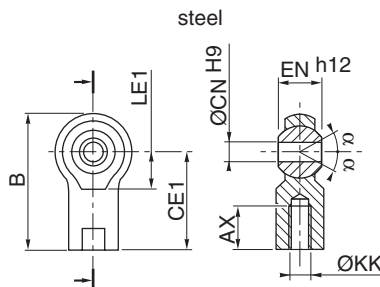
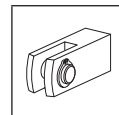

Ø (mm)	AX	B	CE1	ØCN	LE1	ØKK		EN	α	weight
						steel	st. steel			
8	8	36	27	5	10	M4x0,7	-	8	4°	0,020
10	8	36	27	5	10	M4x0,7	-	8	4°	0,020
12	12	40	30	6	11	M6x1	M6x1	9	4°	0,030
16	12	40	30	6	11	M6x1	M8x1	9	4°	0,030
20	15	48	36	8	13	M8x1,25	M8x1,25	12	4°	0,050
25	20	57	43	10	15	M10x1,25	M10x1,25	14	4°	0,070

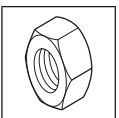

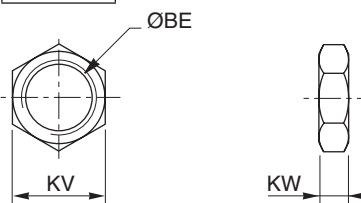

MOUNTING
Front neck nut
MR3



Ø (mm)	ØBE	KV	KW	weight
8	M12x1,25	19	6	0,010
10	M12x1,25	19	6	0,010
12	M16x1,5	19	4	0,010
16	M16x1,5	19	4	0,010
20	M22x1,5	27	5	0,010
25	M22x1,5	27	5	0,010

PRECISE & STURDY CUSHIONING
 . Precise cushioning by means of captive micrometer screws
 . Large cushioning length

MAGNETIC POSITION DETECTOR

 Reed-switch type or magneto-resistive type (MR)
 Installation into the T-slot grooves (see page P291)

T-SLOT GROOVES

 Grooves in 3 sides

EASY MOUNTING
 Wide choice of standard mountings and rod ends

STURDY DESIGN
 Rod in hard chrome steel

ESTHETIC DESIGN
 Cylinders with profiled barrel in hard anodised aluminium

VERSIONS TO ATEX 
 (see page P229-3)

STANDARD SWIVEL TRUNNION MOUNT

 As a fastening option, this trunnion slides on the barrel for on-site positioning.

EASY MAINTENANCE
 . Series 453 cylinders do not require lubrication
 . All the functions in the same side:
 - air ports
 - cushioning adjustment
 - detection

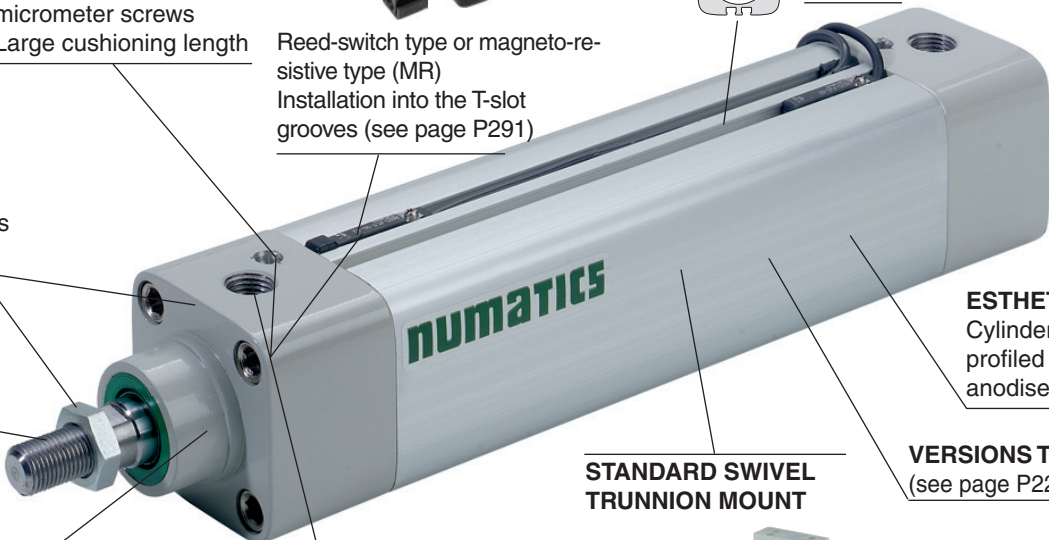
PRECISE ROD GUIDANCE
 With high-performance self-lubricating bearing and non-abrasive scraper seal



OPTIONS (see page P229-3)

STANDARD MOUNTINGS (see page P235)

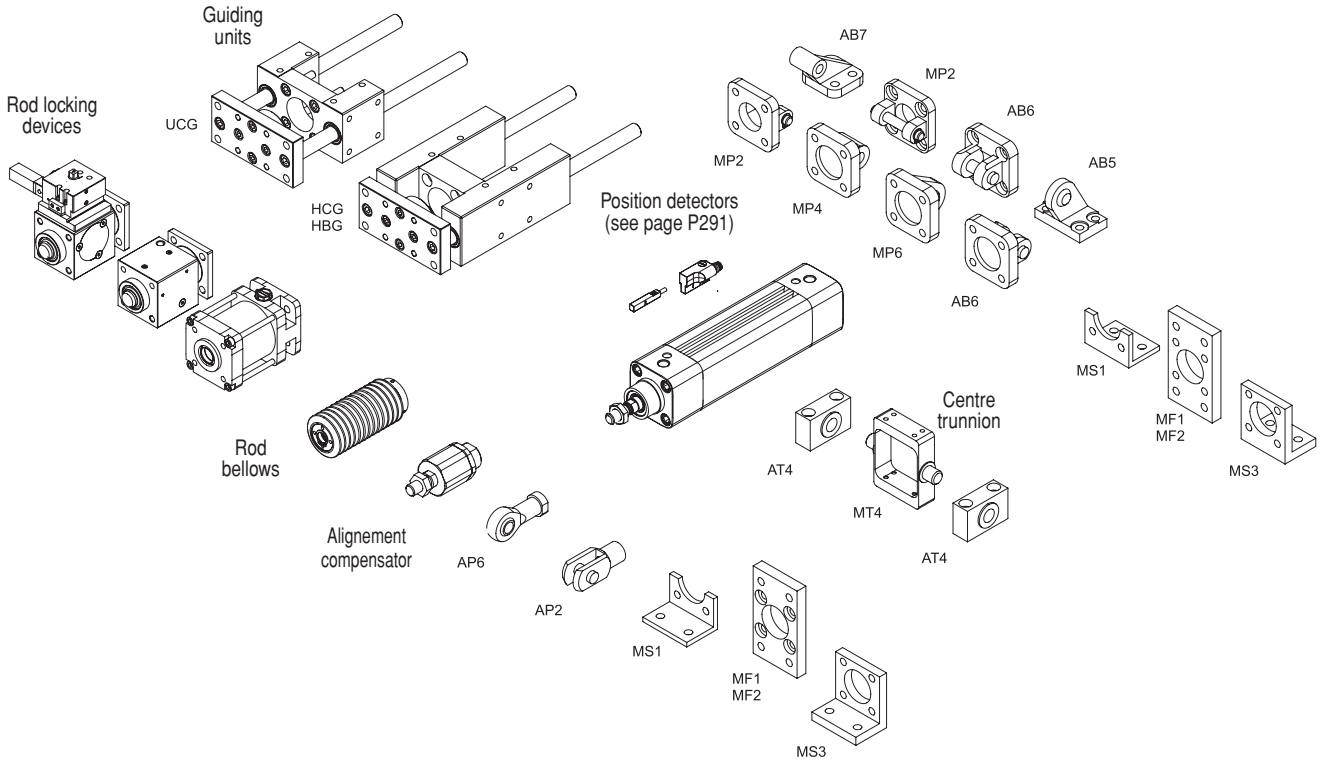

Guiding units
 UCG
 HCG
 HBG

Rod locking devices

Rod bellows

Alignment compensator
 AP6
 AP2

Position detectors (see page P291)

MP2
 MP4
 MP6

AB7
 AB6
 AB5

Centre trunnion
 AT4
 MT4

MS1
 MF1
 MF2
 MS3

SPECIAL ASSEMBLIES (see page P229-13)

CONFIGURABLE INTO PLUG & PLAY UNITS
 5/2 and 5/3 valves with mounting pad to ISO or Namur Mountings, detectors, pneumatic function fittings
 Custom solutions assembled and tested on delivery



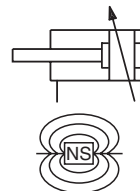

GENERAL

Detection	Equipped for magnetic position detectors
Fluid	Air or inert gas, filtered, lubricated or not
Operating pressure	10 bar, max. [1 bar = 100 kPa]
Ambient temperature	-20°C to +70°C (for higher temperature, see HTP option)
Optimal max. speed	≤ 1 m/s (for optimal service life)
Max. speed rate	2 m/s (for higher and lower speed rate, see LFS option)
Standards	ISO 15552

CONSTRUCTION

Barrel	Hard anodized aluminium alloy	
Front and rear ends	Aluminium alloy	
Bearing	Self-lubricating metal	
Cushioning seals	PUR (polyurethane)	
Cushioning	Pneumatic, adjustable from both sides with captive screw	
Rod	Hard chrome plated steel	
Rod nut	Galvanised steel	
Piston	Ø 32 to 80 mm	POM (polyacetal)
	Ø 100 mm	light alloy
	fitted with an annular permanent magnet	
Piston seals	PUR (polyurethane)	



B

2D/3D CAD models - *In 3D*

HOW TO ORDER

15-DIGIT PRODUCT CODE

G 453 A - S K - - - A00

Thread connection
G = ISO 16030

Product series
453

Revision letter
A = Initial release

Diameter (mm)
3 = 32
4 = 40
5 = 50
6 = 63
8 = 80
1 = 100

Rod options 1

S = Chromed single rod
2 = Through rod
3 = AISI 303 stainless steel rod
4 = AISI 303 stainless steel through rod
6 = AISI 316 stainless steel rod
7 = AISI 316 stainless steel through rod
Stainless steel rod nuts delivered with options 3, 4, 6 & 7.

Rod options 2

K = No option
3 = Static rod-locking device (see P229-24)
4 = Static rod-locking device and manual operator (see P229-24)
5 = Dynamic rod-locking device - Ø 40 to 100 mm (see P229-29)
6 = Oversized piston rod - Ø 63 to 100 mm (see P229-33)
8 = Rod bellow (see P229-35)
T = Eye rod end
Extended piston rod, consult us

Options

A00 = Without
MT4 = Non fixed centre trunnion (MT4 axis perpendicular to the ports)⁽¹⁾
MS4 = Non fixed centre trunnion (MT4 axis parallel to the ports)⁽¹⁾
UCG = Plain bearing "U" guiding unit (see P229-20)
HCG = Plain bearing "H" guiding unit (see P229-20)
HBG = Ball bearing "H" guiding unit (see P229-20)
AT1 = ATEX zones 1/21
AT2 = ATEX zones 2/22
HTP = High temperature (up to 120°C)⁽²⁾
FPM = FPM seals
FFP = FPM front end seals
NPC = Anticorrosion treatment on covers & high-quality rod seals
SCN = Stainless steel cover nuts
LFS = Low friction piston seals - Ø 32 to 80 mm⁽³⁾(see P229-15)
NCS = Without pneumatic cushioning

⁽¹⁾ For fixed supplied centre trunnion, consult our Dynamic Product Modeling Tool on www.asconumatics.eu and indicate XV dimension.

⁽²⁾ Magnetic detectors cannot be fitted to this version.

⁽³⁾ Special characteristics for this option:

- . piston material: light alloy
- . max. speed rate: 3 m/s

Recommended standard strokes (mm) ⁽⁵⁾

Ø mm	connect. Ø (G)	25	50	80	100	125	160	200	250	320	400	500	600	700	800	900	1000	1500	max. stroke
32	G1/8	●	●	●	●	●	●	●	●	●	●								2000
40	G1/4	●	●	●	●	●	●	●	●	●	●	●	●						2000
50	G1/4	●	●	●	●	●	●	●	●	●	●	●	●	●					2000
63	G3/8	●	●	●	●	●	●	●	●	●	●	●	●	●	●				2000
80	G3/8	●	●	●	●	●	●	●	●	●	●	●	●	●	●	●			2000
100	G1/2	●	●	●	●	●	●	●	●	●	●	●	●	●	●	●	●	●	2000

⁽⁵⁾ Other strokes on request. / Min. stroke: 5 mm

POSITION DETECTORS

Magnetic position detectors must be ordered separately: "T" model (see page P291), reed switch or magneto-resistive type

MOUNTINGS

Mountings must be ordered separately: see page P235

DIMENSIONS (mm), WEIGHT (kg)



SINGLE-ROD TYPE CYLINDER

Bare cylinder
ISO 15552



THROUGH-ROD TYPE CYLINDER

Bare cylinder
ISO 15552

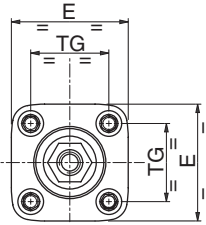
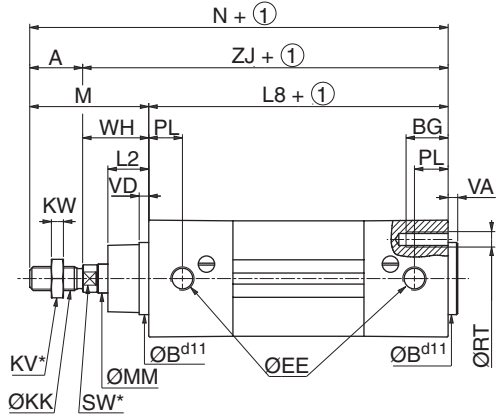

- ① Stroke
- ② Stroke x 2
- * Width across flats

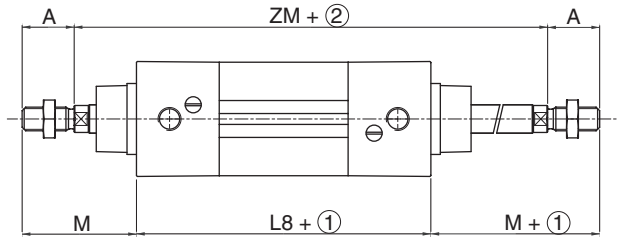

Ø (mm)	A	ØBd11	BG	E	ØEE (3)	ØKK	KV	KW	L2	L8	M	ØMM	N	PL	ØRT	SW	TG	VA	VD min.	WH	ZJ	ZM	weight	
																							(4)	(5)
32	22	30	16	48	G1/8	M10x1,25	16	5	17	94	48	12	142	14	M6	10	32,5 ±0,5	4	4	26	120	146	0,49	0,0029
40	24	35	16	54	G1/4	M12x1,25	18	6	19	105	54	16	159	16	M6	13	38 ±0,5	4	4	30	135	165	0,78	0,0037
50	32	40	16	66	G14	M16x1,5	24	8	24	106	69	20	175	18,5	M8	17	46,5 ±0,5	4	4	37	143	180	1,00	0,0053
63	32	45	16	78	G3/8	M16x1,5	24	8	24	121	69	20	190	19	M8	17	56,5 ±0,5	4	4	37	158	195	1,35	0,0057
80	40	45	17	96	G3/8	M20x1,5	30	10	33	128	86	25	214	16,5	M10	22	72 ±0,5	4	4	46	174	220	2,36	0,0086
100	40	55	17	115	G1/2	M20x1,5	30	10	35,5	138	91	25	229	19,5	M10	22	89 ±0,5	4	4	51	189	240	3,46	0,0099

(3) Thread connections G have standard thread according to ISO 16030.

(4) Cylinder weight at 0 mm stroke.

(5) Weight to be added per additional mm length.

SPARE PARTS KITS CODE

Ø (mm)	1 + 2 + 3 + 4 ⁽¹⁾		rod + piston unit
32	97802343		97802736 ⁽²⁾
40	97802344		97802737 ⁽²⁾
50	97802345		97802738 ⁽²⁾
63	97802346		97802739 ⁽²⁾
80	97802347		97802740 ⁽²⁾
100	97802259		97802741 ⁽²⁾

⁽¹⁾ For best results, use grease supplied in each kit. Supplementary tube (11 cm³) available on request, catalogue number: **97802100**

⁽²⁾ Specify stroke length (in mm).

- All mountings can be used in explosives atmospheres, zones 1-21 and 2-22

SPECIFICATIONS ⁽¹⁾

Ø (mm)				Low feet (set of 2 items) MS1		High foot MS3	Rectangular front or rear flange MF1 - MF2	
449	453	454	450	stamped sheet steel	stainless steel	light alloy	steel	stainless steel
20	-	-	-	P493AL124000A00	-	-	P493AL126000A00	-
25	-	-	-	P493AM124000A00	-	-	P493AM126000A00	-
32	32	32	32	P493A3124000A00	P493A3124200A00	P493A3125100A00	P493A3126000A00	P493A3126200A00
40	40	40	40	P493A4124000A00	P493A4124200A00	P493A4125100A00	P493A4126000A00	P493A4126200A00
50	50	50	50	P493A5124000A00	P493A5124200A00	P493A5125100A00	P493A5126000A00	P493A5126200A00
63	63	63	63	P493A6124000A00	P493A6124200A00	P493A6125100A00	P493A6126000A00	P493A6126200A00
80	80	80	80	P493A8124000A00	P493A8124200A00	P493A8125100A00	P493A8126000A00	P493A8126200A00
100	100	100	100	P493A1124000A00	P493A1124200A00	-	P493A1126000A00	P493A1126200A00
-	-	-	125	P493AP124000A00	-	-	P493AP126000A00	-
-	-	-	160	P493AQ124000A00	-	-	P493AQ126000A00	-
-	-	-	200	P493AR124000A00	-	-	P493AR126000A00	-

Centre trunnion MT4				Centre trunnion MT4		Support for centre trunnion (set of 2 items) MT4		
Ø (mm)		delivered separately	supplied loose	delivered separately	supplied fixed /XV ⁽²⁾	aluminium		
449	453	cast iron		450	cast iron	aluminium		
20	-	-	-	-	-	-	-	
25	-	-	-	-	-	-	-	
32	32	P493A3111000A00	See page: P226-2 and P229-3	32	P493A3113000A00	Check codes on DPM (Dynamic Product Modeling) with our on-line configurator tool at: www.asconumatics.eu		P493A3112100A00
40	40	P493A4111000A00		40	P493A4113000A00			P493A4112100A00
50	50	P493A5111000A00		50	P493A5113000A00			P493A4112100A00
63	63	P493A6111000A00		63	P493A6113000A00			P493A6112100A00
80	80	P493A8111000A00		80	P493A8113000A00			P493A6112100A00
100	100	P493A1111000A00		100	P493A1113000A00			P493A1112100A00
-	-	-		-	125	P493AP113000A00		
-	-	-	-	160	P493AQ113000A00			P493AQ112100A00
-	-	-	-	200	P493AR113000A00			P493AQ112100A00

⁽¹⁾ Refer to the dimensional drawings on the following page.
NOTE: With the exception of the centre trunnion, mountings are delivered separately.
⁽²⁾ Trunnion supplied fixed to the barrel: specify XV dimension when ordering.

REAR MOUNTINGS ⁽¹⁾



Ø (mm)				Cap, detachable clevis MP2			
449	453	454	450	light alloy	cast iron	light alloy anticorrosion (NPC treatment)	stainless steel
20	-	-	-	-	-	-	-
25	-	-	-	-	-	-	-
32	32	32	32	P493A3121110A00	P493A3121010A00	P493A3121100NPC	P493A3121200A00
40	40	40	40	P493A4121110A00	P493A4121010A00	P493A4121100NPC	P493A4121200A00
50	50	50	50	P493A5121110A00	P493A5121010A00	P493A5121100NPC	P493A5121200A00
63	63	63	63	P493A6121110A00	P493A6121010A00	P493A6121100NPC	P493A6121200A00
80	80	80	80	P493A8121110A00	P493A8121010A00	P493A8121100NPC	P493A8121200A00
100	100	100	100	P493A1121110A00	P493A1121010A00	P493A1121100NPC	P493A1121200A00
-	-	-	125	-	P493AP121010A00	-	-
-	-	-	160	-	P493AQ121010A00	-	-
-	-	-	200	-	P493AR121010A00	-	-



Ø (mm)				Cap, detachable eye (trunnion) MP4			
449	453	454	450	light alloy	cast iron	light alloy anticorrosion (NPC treatment)	stainless steel
20	-	-	-	P493AL122110A00	-	-	-
25	-	-	-	P493AM122110A00	-	-	-
32	32	32	32	P493A3122100A00	P493A3122010A00	P493A3122100NPC	P493A3122200A00
40	40	40	40	P493A4122100A00	P493A4122010A00	P493A4122100NPC	P493A4122200A00
50	50	50	50	P493A5122100A00	P493A5122010A00	P493A5122100NPC	P493A5122200A00
63	63	63	63	P493A6122100A00	P493A6122010A00	P493A6122100NPC	P493A6122200A00
80	80	80	80	P493A8122100A00	P493A8122010A00	P493A8122100NPC	P493A8122200A00
100	100	100	100	P493A1122100A00	P493A1122010A00	P493A1122100NPC	P493A1122200A00
-	-	-	125	-	P493AP122010A00	-	-
-	-	-	160	-	P493AQ122010A00	-	-
-	-	-	200	-	P493AR122010A00	-	-





Ø (mm)				Angular clevis bracket AB7				Cap clevis for spherical eye or clevis bracket AB6	Cap eye with spherical eye ⁽²⁾ MP6	Angular clevis bracket spherical bearing ⁽²⁾ AB5
449	453	454	450	light alloy	cast iron	light alloy anticorrosion (NPC treatment)	stainless steel	steel	steel	steel
20	-	-	-	-	-	-	-	-	-	-
25	-	-	-	-	-	-	-	-	-	-
32	32	32	32	P493A3123110A00	P493A3123010A00	P493A3123100NPC	P493A3123200A00	P493A3129000A00	P493A3128000A00	P493A3127000A00
40	40	40	40	P493A4123110A00	P493A4123010A00	P493A4123100NPC	P493A4123200A00	P493A4129000A00	P493A4128000A00	P493A4127000A00
50	50	50	50	P493A5123110A00	P493A5123010A00	P493A5123100NPC	P493A5123200A00	P493A5129000A00	P493A5128000A00	P493A5127000A00
63	63	63	63	P493A6123110A00	P493A6123010A00	P493A6123100NPC	P493A6123200A00	P493A6129000A00	P493A6128000A00	P493A6127000A00
80	80	80	80	P493A8123110A00	P493A8123010A00	P493A8123100NPC	P493A8123200A00	P493A8129000A00	P493A8128000A00	P493A8127000A00
100	100	100	100	P493A1123110A00	P493A1123010A00	P493A1123100NPC	P493A1123200A00	P493A1129000A00	P493A1128000A00	P493A1127000A00
-	-	-	125	-	P493AP123010A00	-	-	P493AP129000A00	P493AP128000A00	P493AP127000A00
-	-	-	160	-	P493AQ123010A00	-	-	-	-	-
-	-	-	200	-	P493AR123010A00	-	-	-	-	-

⁽¹⁾ Refer to the dimensional drawings on the following page.

⁽²⁾ These accessories allows accurate angular compensation adjustment spherical of 4°.

ROD MOUNTINGS ⁽¹⁾

									
				Femelle rod clevis ⁽²⁾ AP2		Spherical rod end AP6		Alignment compensator ⁽³⁾	
Ø (mm)				steel	stainless steel	steel	stainless steel	steel	
449	453	454	450						
20-25	-	-	-	P493AL431000A00	-	P493AL432000A00			-
32-40	32	32	32	P493A3131000A00	P493A3131200A00	P493A3132000A00	P493A3132200A00	P493A3134000A00	
50-63	40	40	40	P493A4131000A00	P493A4131200A00	P493A4132000A00	P493A4132200A00	P493A4134000A00	
80-100	50-63	50-63	50-63	P493A5131000A00	P493A5131200A00	P493A5132000A00	P493A5132200A00	P493A5134000A00	
-	80-100	80-100	80-100	P493A8131000A00	P493A8131200A00	P493A8132000A00	P493A8132200A00	P493A8134000A00	
-	-	-	125	P493AP131000A00	-	P493AP132000A00	-	-	
-	-	-	160-200	P493AQ131000A00	-	P493AQ132000A00	-	-	

⁽¹⁾ Refer to the dimensional drawings on the following page.

⁽²⁾ Ø125 to 200 mm: Clevis with axis locking pin

⁽³⁾ This accessory allows accurate angular compensation adjustment spherical of 4° and radial of 0,7 mm.

B

DIMENSIONS (mm), WEIGHT (kg)

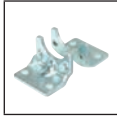

MOUNTING
Low foot
MS1

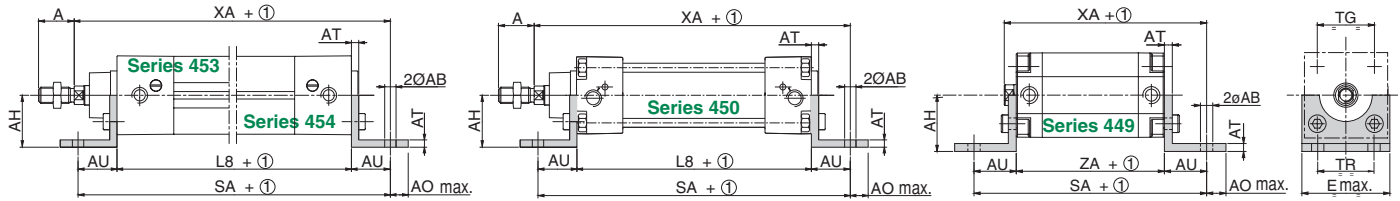

① Stroke

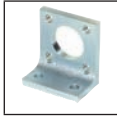

MOUNTING
High foot
MS3

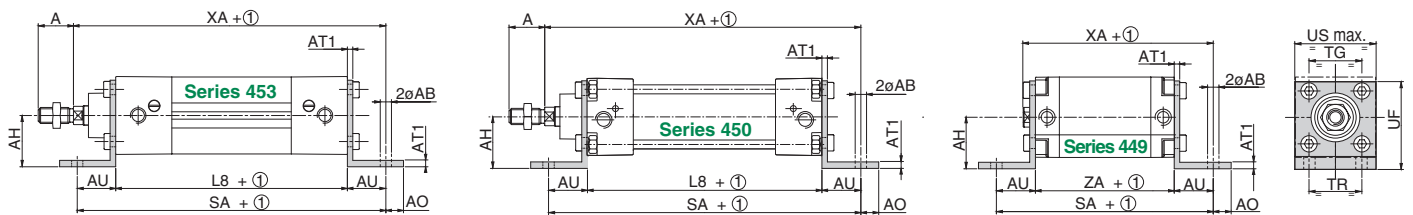

① Stroke

Ø (mm)				ØAB	A	AO	AH	AT	AT1	AU	E	L8	SA		TR	TG	UF	US	XA		ZA	weight	
449	453	454	450										449	453/454/450					449	453/454/450		2 x MS1	1 x MS3
20	-	-	-	7	-	7	27	4	-	16	38	-	69	-	22	22	-	-	59	-	37	0,064	-
25	-	-	-	7	-	7	29	4	-	16	41	-	71	-	26	26	-	-	61	-	39	0,076	-
32	32	32	32	7	22	11	32	4	8	24	50	94	92	142	32	32,5	54	50	79	144	44	0,150	0,180
40	40	40	40	10	24	15	36	4	8	28	58	105	101	161	36	38	62	58	83	163	45	0,190	0,250
50	50	50	50	10	32	15	45	5	10	32	70	106	109	170	45	46,5	77	70	88	175	45	0,395	0,470
63	63	63	63	10	32	15	50	5	10	32	85	121	113	185	50	56,5	87	85	91,5	190	49	0,445	0,595
80	80	80	80	12	40	20	63	6	12	41	105	128	146	210	63	72	110	105	107,5	215	54	0,790	1,265
100	100	100	100	14,5	40	25	71	6	12	41	130	138	149	220	75	89	130	130	128,5	230	67	1,400	-
-	-	-	125	16,5	54	25	90	8	16	45	157	160	-	250	90	110	161	157	-	270	-	2,330	-
-	-	-	160	18,5	72	25	115	10	-	60	195	180	-	300	115	140	-	-	-	320	-	4,860	-
-	-	-	200	24	72	35	135	12	-	70	238	180	-	320	135	175	-	-	-	345	-	7,900	-



MOUNTING
Front or rear flange
MF1 - MF2
Rectangular

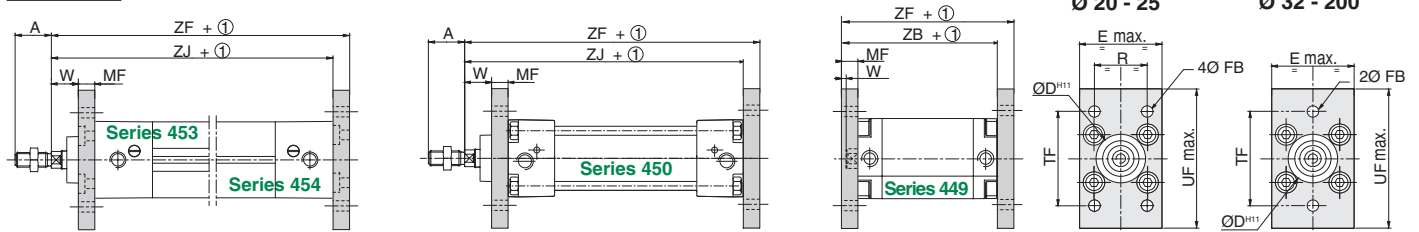

① Stroke

Ø (mm)				A	ØD	E	ØFB	MF	R	TF	UF	W		ZB	ZJ	ZF		weight
449	453	454	450									449	453/454/450			449	453/454/450	
20	-	-	-	-	16	38	6,6	8	-	55	70	2	-	43	-	51	-	0,016
25	-	-	-	-	16	41	6,6	8	-	60	76	2	-	45	-	53	-	0,020
32	32	32	32	22	30	50	7	10	32	64	86	3	16	55	120	65	130	0,190
40	40	40	40	24	35	58	9	10	36	72	96	3	20	55	135	65	145	0,245
50	50	50	50	32	40	70	9	12	45	90	115	4	25	56	143	67	155	0,500
63	63	63	63	32	45	85	9	12	50	100	130	4	25	59,5	158	71,5	170	0,580
80	80	80	80	40	45	105	12	16	63	126	165	6	30	66,5	174	82,5	190	1,390
100	100	100	100	40	55	130	14	16	75	150	187	6	35	77,5	189	93,5	205	1,630
-	-	-	125	54	60	157	16	20	90	180	224	-	45	-	225	-	245	4,270
-	-	-	160	72	65	195	18	20	115	230	280	-	60	-	260	-	280	6,880
-	-	-	200	72	75	238	22	25	135	270	320	-	70	-	275	-	300	12,330

DIMENSIONS (mm), WEIGHT (kg)



MOUNTING

Centre trunnion

MT4

(Series 449-453)

XV Dimension must be specified when ordering.



MOUNTING

Centre trunnion

MT4

(Series 450)

XV Dimension must be specified when ordering.

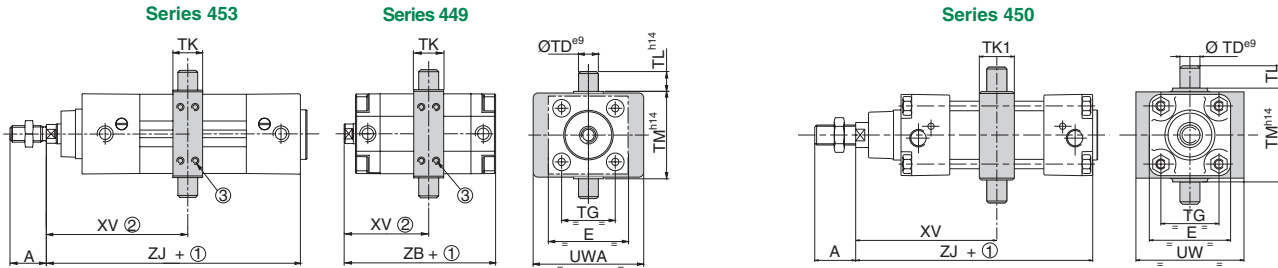

- ① Stroke
- ② Except when XV dimension is specified when ordering, the position of the trunnion may be adjusted along the unit. Consequently, the centre trunnion is not screwed on and must be adjusted after delivery.
- ③ 8 locking screws.

Ø (mm)			A	E	TD	TG	TK	TK1	TL	TM	UW	UWA	ZB	ZJ	XV min.			XV max.			min. stroke	weight		
449	453	450													449	453	450	449	453	450		449	449/453	450
20	-	-	-	-	-	-	-	-	-	-	-	-	-	-	-	-	-	-	-	-	-	-	-	-
25	-	-	-	-	-	-	-	-	-	-	-	-	-	-	-	-	-	-	-	-	-	-	-	-
32	32	32	22	56	12	32,5	18	22	12	50	55	64,5	55	120	32,3	71,5	72	25,9	75	74,5	6,5	0,185	0,2	-
40	40	40	24	67	16	38	20	28	16	63	58	74,5	55	135	34	81	83	25	84,2	82	9	0,33	0,4	-
50	50	50	32	89	16	46,5	20	28	16	75	68	91	56	143	37	89,5	89,5	24	91,3	91	13	0,475	0,5	-
63	63	63	32	89	20	56,6	25	35	20	90	84	94	59,5	158	40	89,5	93,5	25	102	102,5	15	0,57	0,9	-
80	80	80	40	112	20	72	25	35	20	110	102	130	66,5	174	44,5	106,5	106,5	29,5	114	114,5	15	1,12	1,1	-
100	100	100	40	112	25	89	30	40	25	132	145	145	87,5	189	52,5	116,5	114	34,8	124	126,5	18	1,52	1,86	-
-	-	125	54	155	25	110	40	40	25	160	175	175	-	225	-	-	135	-	-	155,5	-	-	2,55	-
-	-	160	72	201	32	140	50	50	32	200	220	220	-	260	-	-	159,5	-	-	181	-	-	4,7	-
-	-	200	72	201	32	175	50	50	32	250	260	260	-	275	-	-	173,5	-	-	197	-	-	4,2	-



MOUNTING

Support for centre trunnion (set of 2 items)

MT4

(Series 449-453-450)

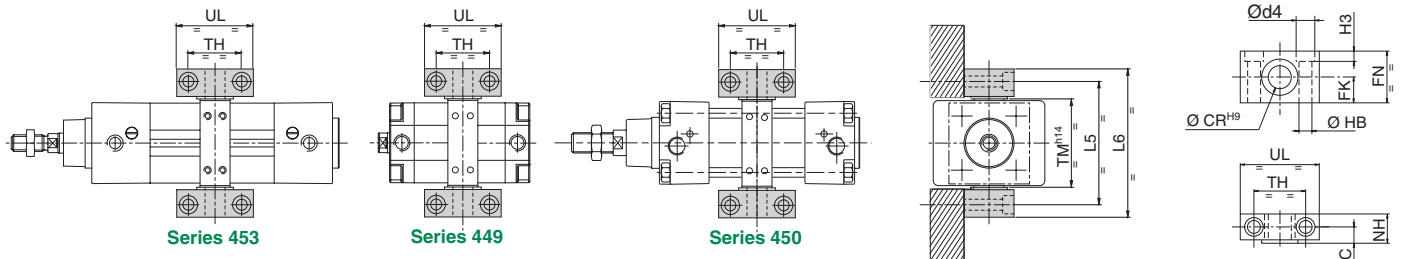

Ø (mm)			C	ØCR	Ød4	FK	FN	HB	H3	L5	L6	NH	TH	TM	UL	weight
449	453	450														
20	-	-	-	-	-	-	-	-	-	-	-	-	-	-	-	-
25	-	-	-	-	-	-	-	-	-	-	-	-	-	-	-	-
32	32	32	10,5	12	11	15	30	6,6	6,8	71	86	18	32	50	46	0,12
40	40	40	12	16	15	18	36	9	9	87	105	21	36	63	55	0,23
50	50	50	12	16	15	18	36	9	9	99	117	21	36	75	55	0,23
63	63	63	13	20	18	20	40	11	11	116	136	23	40	90	65	0,33
80	80	80	13	20	18	20	40	11	11	136	156	23	40	110	65	0,33
100	100	100	16	25	20	25	50	13,5	13	164	189	28,5	50	132	75	0,58
-	-	125	16	25	20	25	50	13,5	13	192	219	28,5	50	160	75	0,58
-	-	160	22,5	32	26	30	60	17,5	17,5	245	280	40	60	200	92	1,03
-	-	200	22,5	32	26	30	60	17,5	17,5	295	330	40	60	250	92	1,03

01416GB-2012/R03
Availability, design and specifications are subject to change without notice. All rights reserved.

B

DIMENSIONS (mm), WEIGHT (kg)



REAR MOUNTING
Cap, detachable clevis
MP2

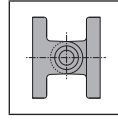
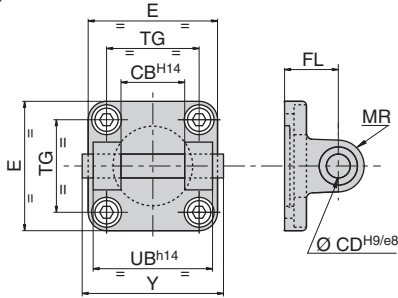

MP2 + MP4
Cap, detachable clevis
+
Cap, detachable eye (trunnion)

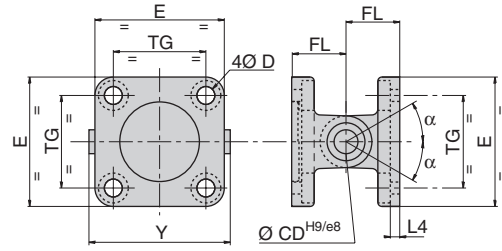

REAR MOUNTING
Cap, detachable eye (trunnion)
MP4

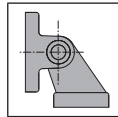
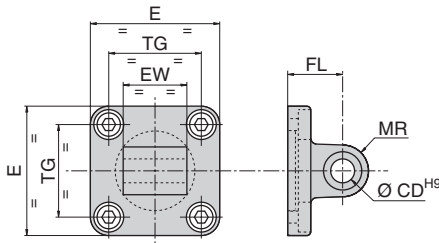

MP2 + AB7
Cap, detachable clevis
+
Angular clevis bracket

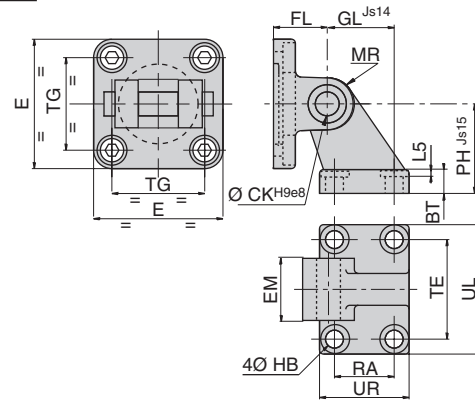

REAR MOUNTING
Angular clevis bracket
AB7

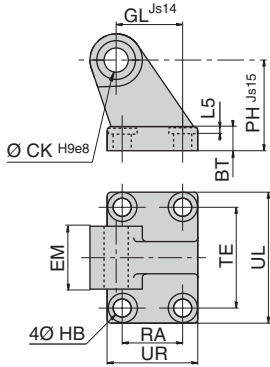

① Stroke

Ø (mm)				weight								
				light alloy			cast iron			stainless steel		
449	453	454	450	MP2	MP4	AB7	MP2	MP4	AB7	MP2	MP4	AB7
20	-	-	-	-	0,085	-	-	0,21	-	-	-	-
25	-	-	-	-	0,092	-	-	0,23	-	-	-	-
32	32	32	32	0,105	0,085	0,16	0,205	0,21	0,34	0,41	0,41	0,16
40	40	40	40	0,15	0,092	0,23	0,305	0,23	0,45	0,67	0,67	0,24
50	50	50	50	0,24	0,17	0,39	0,43	0,43	0,79	0,97	0,97	0,42
63	63	63	63	0,37	0,25	0,57	0,685	0,62	1,08	1,585	1,585	0,525
80	80	80	80	0,635	0,445	0,95	1,375	1,1	2,09	3,46	3,46	1,055
100	100	100	100	0,99	0,755	0,5	2,1	1,7	2,75	5,35	5,35	1,36
-	-	-	125	-	-	-	3,57	3,1	6,61	-	-	-
-	-	-	160	-	-	-	6,66	5,22	12,47	-	-	-
-	-	-	200	-	-	-	9,89	7,78	16,76	-	-	-

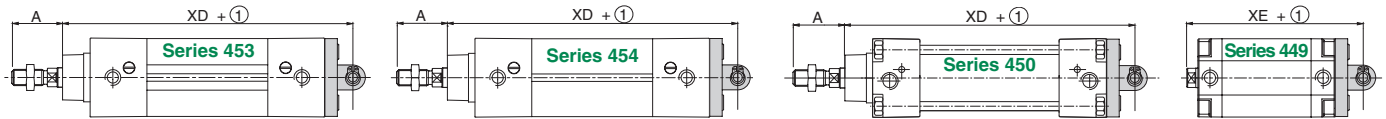

Ø (mm)				A	BT	CB EM	CD CK	D	E	EW	FL	GL	HB	L4	L5	MR	PH	RA	TE	TG	UB	UR	UL	XD	XE	Y	α
449	453	454	450																								
20	-	-	-	-	-	-	8	-	38	16	20	-	-	-	9	-	-	-	22	-	-	-	-	63	-	-	
25	-	-	-	-	-	-	8	-	41	16	20	-	-	-	9	-	-	-	26	-	-	-	-	65	-	-	
32	32	32	32	22	8	26	10	6,6	50	26	22	21	6,6	5,5	1,6	11	32	18	38	32,5	45	31	51	142	73	56	45°
40	40	40	40	24	10	28	12	6,6	58	28	25	24	6,6	5,5	1,6	13	36	22	41	38	52	35	54	160	77	63	50°
50	50	50	50	32	12	32	12	9	70	32	27	33	9	6,5	1,6	13	45	30	50	46,5	60	45	65	170	80	71	40°
63	63	63	63	32	12	40	16	9	85	40	32	37	9	6,5	1,6	17	50	35	52	56,5	70	50	67	190	89	81	55°
80	80	80	80	40	14	50	16	11	105	50	36	47	11	10	2,5	17	63	40	66	72	90	60	86	210	100	101	45°
100	100	100	100	40	15	60	20	11	130	60	41	55	11	10	2,5	21	71	50	76	89	110	70	96	230	118	128	35°
-	-	-	125	54	20	70	25	14	157	70	50	70	14	10	3,2	26	90	60	94	110	130	90	124	275	-	149	30°
-	-	-	160	72	25	90	30	14	195	90	55	97	14	10	4	31	115	88	118	140	170	126	156	315	-	183	30°
-	-	-	200	72	30	90	30	18	238	90	60	105	18	11	4	31	135	90	122	175	170	130	162	335	-	183	30°

DIMENSIONS (mm), WEIGHT (kg)



REAR MOUNTING
Cap clevis for spherical eye or clevis bracket
AB6

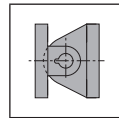
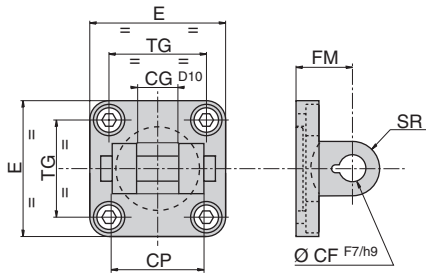

AB6 + MP6
Cap clevis for spherical eye or clevis bracket
+ Cap eye with spherical eye

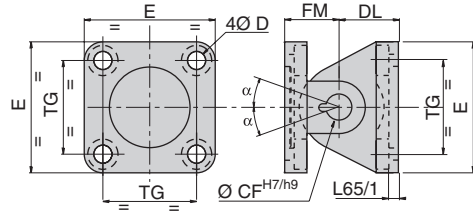

REAR MOUNTING
Cap eye with spherical eye
MP6

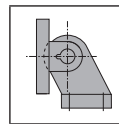
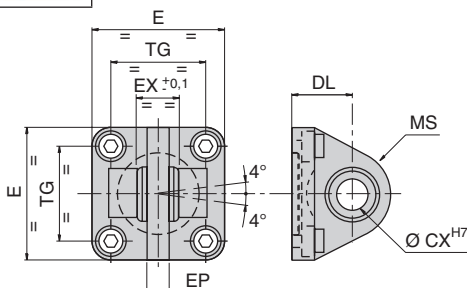

AB6 + AB5
Cap clevis for spherical eye or clevis bracket
+ Angular clevis bracket spherical bearing

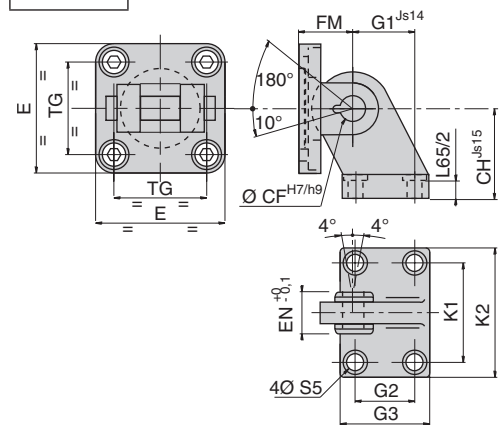

REAR MOUNTING
Angular clevis bracket spherical bearing
AB5

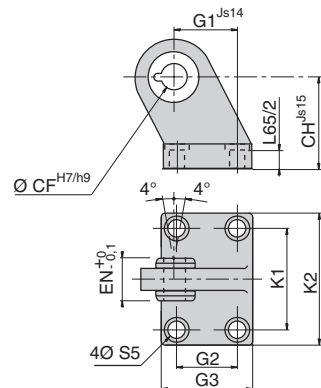

Ø (mm)				weight steel		
449	453	454	450	AB6	AB5	MP6
20	-	-	-	-	-	-
25	-	-	-	-	-	-
32	32	-	32	0,190	0,180	0,180
40	40	-	40	0,300	0,230	0,290
50	50	-	50	0,460	0,450	0,420
63	63	-	63	0,680	0,520	0,650
80	80	-	80	1,460	0,940	1,210
100	100	-	100	2,130	1,070	1,870
-	-	-	125	4,240	2,470	3,640
-	-	-	160	-	-	-
-	-	-	200	-	-	-

① Stroke

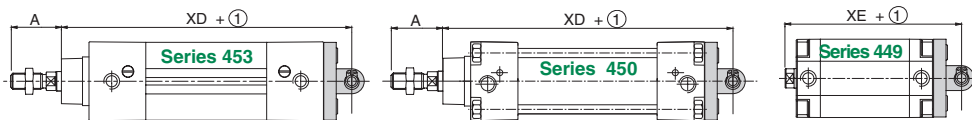

Ø (mm)				A	CG	CH	CP	CX CF	DL FM	E max.	EN EX	EP	G1	G2	G3 max.	K1	K2 max.	L65/1	L65/2	MS max.	TG	SR max.	S5 D	XD	XE	α	
449	453	454	450	-	-	-	-	-	-	-	-	-	-	-	-	-	-	-	-	-	-	-	-	-	-	-	
20	-	-	-	-	-	-	-	-	-	-	-	-	-	-	-	-	-	-	-	-	-	-	-	-	-	-	
25	-	-	-	-	-	-	-	-	-	-	-	-	-	-	-	-	-	-	-	-	-	-	-	-	-	-	
32	32	-	32	22	14	32	34	10	22	50	14	10,5	21	18	31	38	51	5,5	8,5	15	32,5	11	6,6	142	73	40°	
40	40	-	40	24	16	36	40	12	25	58	16	12	24	22	35	41	54	5,5	8,5	18	38	13	6,6	160	77	45°	
50	50	-	50	32	21	45	45	16	27	70	21	15	33	30	45	50	65	6,5	10	20	46,5	18	9	170	80	35°	
63	63	-	63	32	21	50	51	16	32	85	21	15	37	35	50	52	67	6,5	10	23	56,5	18	9	190	89	50°	
80	80	-	80	40	25	63	65	20	36	105	25	18	47	40	60	66	86	10	11,5	27	72	22	11	210	100	40°	
100	100	-	100	40	25	71	75	20	41	130	25	18	55	50	70	76	96	10	12,5	30	89	22	11	230	118	30°	
-	-	-	125	54	37	90	97	30	50	157	37	25	70	60	90	94	124	10	16,5	40	110	30	14	275	-	25°	
-	-	-	160	72	-	-	-	-	-	-	-	-	-	-	-	-	-	-	-	-	-	-	-	-	315	-	-
-	-	-	200	72	-	-	-	-	-	-	-	-	-	-	-	-	-	-	-	-	-	-	-	-	335	-	-

01434GB-2013//R02 Availability, design and specifications are subject to change without notice. All rights reserved.

B

DIMENSIONS (mm), WEIGHT (kg)



ROD MOUNTING

Female rod clevis
AP2



ROD MOUNTING

Spherical rod end
AP6

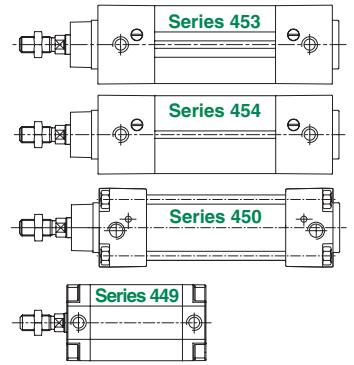
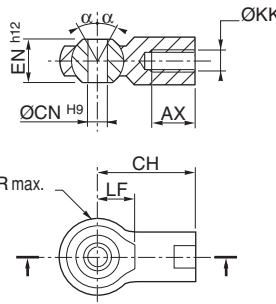
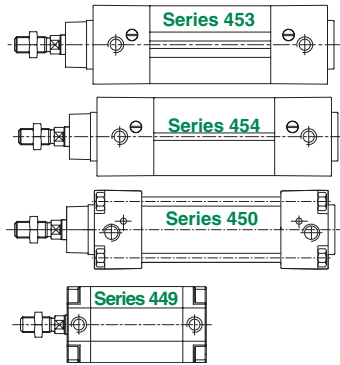
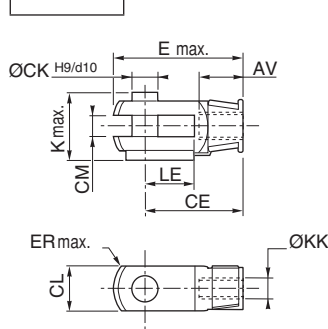

Ø (mm)					AV AX	CE	CH	ØCK	CL	CM	ØCN	E max.	EN	ER max.	K	ØKK	LE	LF	α	weight			
	449	453	454	450																steel		stainless steel	
																				AP2	AP6	AP2	AP6
20	-	-	-	-	15	32	36	8	16	8 ^{+0.5 +0.15}	8	42	12	12	22	M8x1,25	16	13	4°	0,05	0,05	-	-
25	-	-	-	-	15	32	36	8	16	8 ^{+0.5 +0.15}	8	56	14	14	22	M10x1,25	20	15	4°	0,1	0,07	-	-
32	32	32	32	-	20	40	43	10	20	10 ^{+0.5 +0.15}	10	56	14	14	26	M10x1,25	20	15	4°	0,1	0,07	0,09	0,08
40	-	-	-	-	20	40	43	10	20	10 ^{+0.5 +0.15}	10	56	14	14	26	M10x1,25	20	15	4°	0,1	0,07	-	-
-	40	40	40	-	22	48	50	12	24	12 ^{+0.5 +0.15}	12	67	16	16	32	M12x1,25	24	17	4°	0,15	0,12	0,16	0,12
50	-	-	-	-	22	48	50	12	24	12 ^{+0.5 +0.15}	12	67	16	16	32	M12x1,25	24	17	4°	0,15	0,12	-	-
-	50	50	50	-	28	64	64	16	32	16 ^{+0.5 +0.15}	16	89	21	21	41	M16x1,5	32	22	4°	0,33	0,22	0,31	0,23
63	-	-	-	-	22	48	50	12	24	12 ^{+0.5 +0.15}	12	67	16	16	32	M12x1,25	24	17	4°	0,15	0,12	-	-
-	63	63	63	-	28	64	64	16	32	16 ^{+0.5 +0.15}	16	89	21	21	41	M16x1,5	32	22	4°	0,33	0,22	0,31	0,23
80	-	-	-	-	28	64	64	16	32	16 ^{+0.5 +0.15}	16	89	21	21	41	M16x1,5	32	22	4°	0,33	0,22	-	-
-	80	80	80	-	33	80	77	20	40	20 ^{+0.6 +0.15}	20	112	25	25	48	M20x1,5	40	26	4°	0,67	0,39	0,67	0,42
100	-	-	-	-	28	64	64	16	32	16 ^{+0.5 +0.15}	16	89	21	21	41	M16x1,5	32	22	4°	0,33	0,22	-	-
-	100	100	100	-	33	80	77	20	40	20 ^{+0.6 +0.15}	20	112	25	25	48	M20x1,5	40	26	4°	0,67	0,39	0,67	0,42
-	-	-	-	-	125	110	110	30	55	30 ^{+0.6 +0.15}	30	155	37	35	65	M27x2	54	36	4°	1,81	1,6	-	-
-	-	-	-	-	160	144	125	35	70	35 ^{+0.6 +0.15}	35	201	43	40	84	M36x2	72	41	4°	3,85	1,6	-	-
-	-	-	-	-	200	144	125	35	70	35 ^{+0.6 +0.15}	35	201	43	40	84	M36x2	72	41	4°	3,85	1,6	-	-



ROD MOUNTING

Alignment compensator

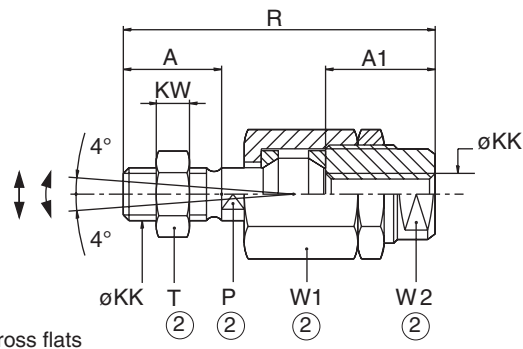

- ① Stroke
- ② Width across flats

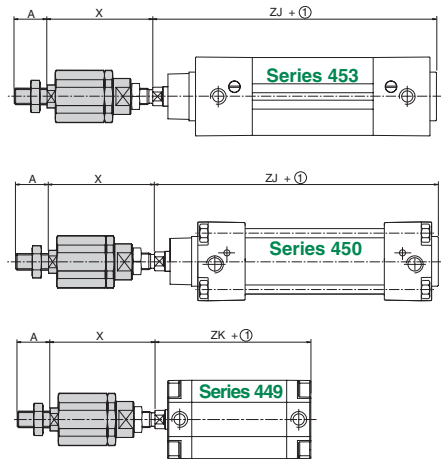

Ø (mm)	A	A1	P	ØKK	KW	R	T	W1	W2	X min.	ZJ	ZK	radial compensation (mm)	spherical angular compensation (°)	weight													
449	-	-	●	-	●	-	●	-	●	-	●	-	●	-	●													
-	453	450	-	●	-	●	-	●	-	●	-	●	-	●	●													
20	-	-	16	-	18	-	7	-	M8x1,25	-	4	-	55	-	13	-	17	-	10	-	45	-	43	0,5	-	4	0,06	
25	-	-	16	-	18	-	7	-	M8x1,25	-	4	-	55	-	13	-	17	-	10	-	45	-	45	0,5	-	4	0,06	
32	32	32	22	22	26	23	12	12	M10x1,25	M20x1,25	6	6	73	71	17	17	30	30	19	19	58	56	120	51	0,7	0,7	4	0,22
40	40	40	22	24	26	23	12	12	M10x1,25	M12x1,25	6	7	73	75	17	19	30	30	19	19	58	57	135	52	0,7	0,7	4	0,23
50	50	50	24	32	26	32	12	20	M12x1,25	M16x1,5	7	8	77	103	19	24	30	41	19	27	59	79	143	53	0,7	1	4	0,66
63	63	63	24	32	26	32	12	20	M12x1,25	M16x1,5	7	8	77	103	19	24	30	41	19	27	59	79	158	57	0,7	1	4	0,66
80	80	80	32	40	34	39	19	20	M16x1,5	M20x1,5	8	10	106	119	24	30	42	41	30	27	82	89	174	64	1	1	4	0,7
100	100	100	32	40	34	39	19	20	M16x1,5	M20x1,5	8	10	106	119	24	30	42	41	30	27	82	89	189	77	1	1	4	0,7
-	-	-	125	-	54	-	40	-	24	-	13,5	-	147	-	41	-	Ø62	-	54	-	107	225	-	-	1	4	1,7	

NOTE: The compensator is preset with an axial clearance of 0,05 to 0,1 - Do not reset.