



Sample image

**CA10**

Type Size: S0  
 Classification Contact: SOLID CONTACT  
 Classification Contact Mat: SILVER  
 Classification Terminal: SCREW TERMINAL  
 Contact development: A215  
 Face plate engraving: F990  
 Type of mounting: ER  
 Reference number: CA10 A215-603 ER

**IEC 60947-3 EN 60947-3, VDE 0660 Teil 107**

<b>Rated insulation voltage Ui</b>		Voltage (V) AC / DC	
		690 AC / DC	
<b>Rated impulse withstand voltage Uimp</b>			
Voltage (kV)	Overvoltage category	Pollution degree	Supply system
4 III		3	Valid for lines with grounded common neutral termination
<b>Function</b>			
Switch disconnecter			
<b>Rated uninterrupted current Iu/Ith</b>			
Current (A)	Ambient temperature (°C)	Peak temperature (°C)	additional requirements
20	55	60	Ambient temperature +55°C during 24 hours with peaks up to +60°C
<b>Rated operational current Ie</b>			
<b>Utilization category</b>		Voltage (V)	Current (A)
AC-15		220-240	6
AC-15		380-440	4
<b>Rated operational power</b>			
Utilization category	Voltage (V)	No. of phases	No. of poles
AC-3	220-240	3	3
AC-3	380-440	3	3
AC-3	660-690	3	3
AC-3	220-240	1	2
AC-3	380-440	1	2
AC-23A	220-240	3	3
AC-23A	380-440	3	3
AC-23A	660-690	3	3
AC-23A	220-240	1	2
AC-23A	380-440	1	2
<b>Power (kW)</b>			
3			
5,50			
5,50			
2,20			
3			
3,70			
7,50			
7,50			
2,50			
3,70			
<b>Current (A)</b>			
--			
11,50			
--			
--			
--			
--			
--			
--			
--			
--			
<b>Max Fuse Rating IEC</b>			
Fuse characteristic	Numb Fuses		Current (A)
gG	1		25

**UL60947-4-1 , UL508**

<b>Nominal Voltage</b>		Voltage (V) AC / DC	
		300 AC / DC	
<b>Horsepower rating</b>			
<b>Across-the-Line Motor Starting</b>		Voltage (V)	No. of phases
Reversing		110-120	1
Reversing		220-240	1
Reversing		277-277	1
Reversing		110-120	3
Reversing		220-240	3
		No. of poles	Power (HP)
		2	0,17
		2	0,50
		2	0,60
		3	0,50
		3	1
<b>SCCR / Max. fuse rating</b>			
<b>Conditions of acceptability</b>			
These devices are suitable for use on circuits capable of delivering not more than 5000 rms symmetrical amperes, 600V ac max. when protected by Class RK1 fuses. Manual Motor Controllers when intended for use as a motor disconnecter are suitable for use on a circuit capable of delivering not more than 5000 rms symmetrical amperes, 600V ac max. when protected by 30A Class J time delay fuses.			
<b>Temp. rating of wire</b>			
		Temperature rating (°C)	Current (A)
		60-75	--
<b>Connecting instructions</b>			
<b>Markings</b>			
When intended for use as a motor disconnecter the device shall be provided with a method of being locked in the OFF-position.			

General Use					
AC / DC	Voltage (V)	Current (A)	No. of phases	No. of poles	No. of contacts in series
AC	300	20	1	2	1
AC	300	20	3	3	1

Rated insulation voltage Ui	
Voltage (V)	AC / DC
300	AC

Rated thermal current		
Current (A)	Ambient temperature (°C)	Additional Text
20	0-40	

Horsepower rating					
Across-the-Line Motor Starting					
	Voltage (V)	No. of phases	No. of poles	Power (HP)	
DOL	110-120	1	2	0,50	
DOL	220-240	1	2	1	
DOL	277-277	1	2	2	
DOL	110-120	3	3	1,50	
DOL	220-240	3	3	3	

Pilot duty rating code	
Duty Code	
A300	

## CSA

Nominal Voltage	
Voltage (V)	AC / DC
300	AC

Temp. rating of wire	
Temperature rating (°C)	Current (A)
75	--

General Use					
AC / DC	Voltage (V)	Current (A)	No. of phases	No. of poles	No. of contacts in series
AC	300	20	1	1	1

## GENERAL TECHNICAL INFORMATION

Tightening torque of screws	
tightening torque (Nm)	tightening torque (lb-in)
0,60	5

Stripping length	
Length (mm)	--
8	STRIPPINGLENGTH

Size of conductor				
composition of conductor	Min. / Max. value	No. of conductor per terminal	Cross section (mm <sup>2</sup> ) or (AWG/kcmil)	Material of the wire
solid wire	Min.	1	0.5mm <sup>2</sup>	Copper
solid wire	Min.	2	0.5mm <sup>2</sup>	Copper
flexible wire	Min.	1	0.75mm <sup>2</sup>	Copper
flexible wire	Min.	2	0.75mm <sup>2</sup>	Copper
flexible wire	Max.	2	2.5mm <sup>2</sup>	Copper
flexible wire	Max.	2	AWG 14	Copper
Single-core or stranded wire	Max.	2	AWG 12	Copper
Single-core or stranded wire	Max.	2	2.5mm <sup>2</sup>	Copper
flexible wire with ferrule according to DIN 46228	Max.	2	2.5mm <sup>2</sup>	Copper
flexible wire with ferrule according to DIN 46228	Min.	1	0.5mm <sup>2</sup>	Copper
flexible wire with ferrule according to DIN 46228	Min.	2	0.5mm <sup>2</sup>	Copper

Recommended screw driver	
Type of screw driver	Value
Cross Screwdriver	PH1
Flat blade	0,8x4

### General Information

Text

Do not lubricate or treat contacts.

Switches may only be mounted, connected and set into operation by qualified persons according to the accepted rules of technology.

Use copper wire only. Do not coat the wire end with tin.

Terminals with factory fitted jumper links are tightened during production. Take care during installation to ensure factory fitted links are not lost by undoing both sides of linked terminals. After wiring, all terminal screws must be tightened to recommended torque specifications.

After installation of the switches the spacings between the terminals must be sufficient to fulfill the requirement of the applicable standards.





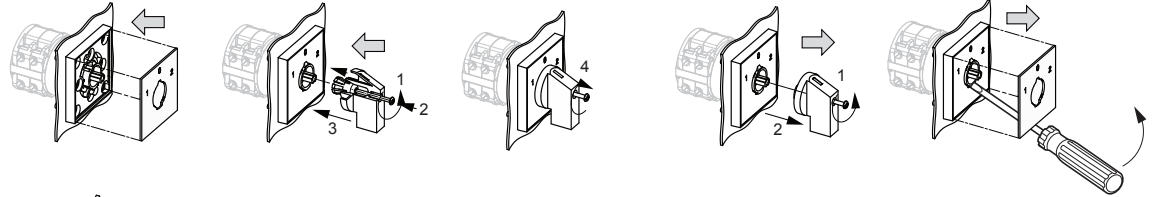

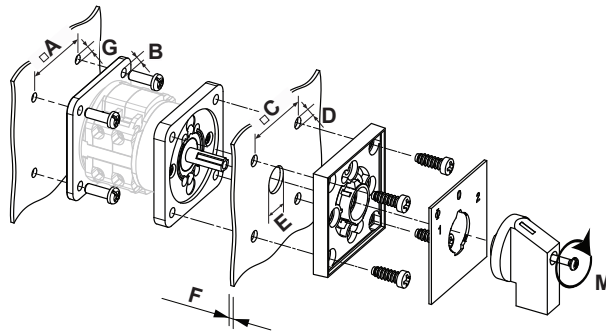

**Mounting-ER**

Mounting-ER



BF\_C\_ER



IP - Code front side		IP40
Stages		1,00 - 12,00
A		36,00 mm
B		4,10 mm
C		36,00 mm
D		5,00 mm
E		8,00 - 19,00 mm
F		<= 4,00 mm
G		5,00 mm
M		0,50 Nm

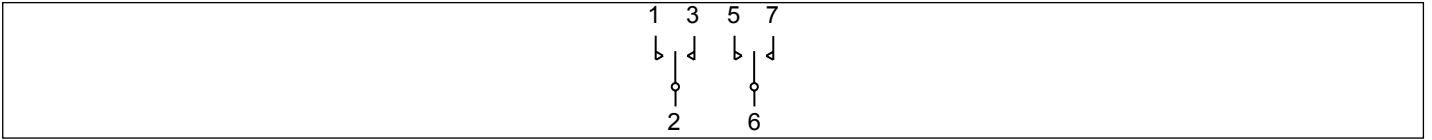

## F990

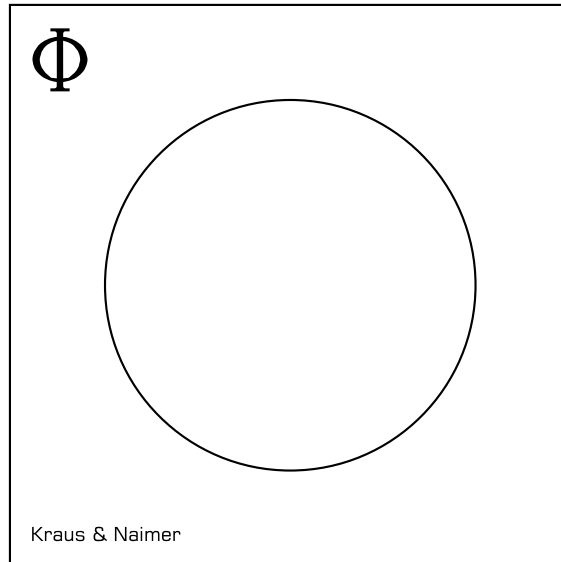

## G-1

### S0C.G251

Handle colour: \*1\* black

#### G-1 HANDLES

#### S0C.G251

