

PROFINET

BK9103

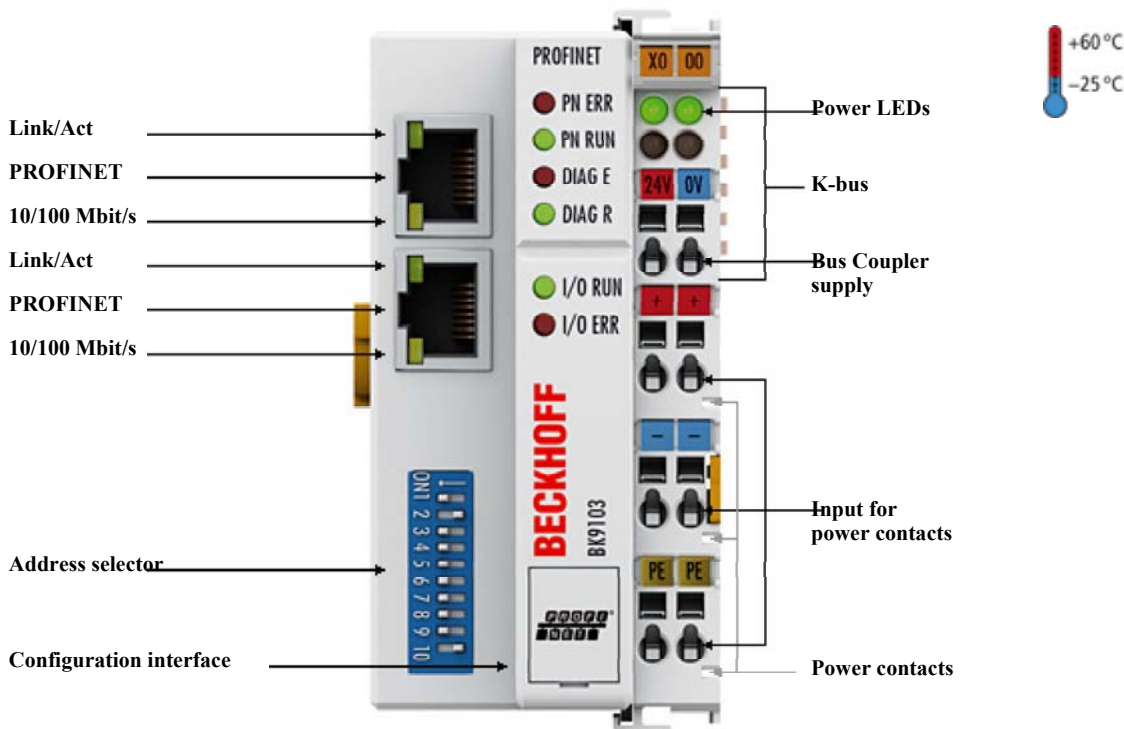

BK9103 | PROFINET Bus Coupler



The BK9103 Bus Coupler connects PROFINET RT with the modular, extendable elec consists of one Bus Coupler, any number from 1 to 64 terminals (255 with K-bus exte

The Bus Couplers recognise the terminals to which they are connected, and perform th outputs to the words of the process image automatically. The BK9103 Bus Coupler supports 10 Mbit/s and through normal RJ45 connectors. The IP address is set on the DIP switch (offset to a freely selectable start ; service for the allocation of the logical IP address to the physical node address [MAC-ID]) the Bus Coupler DHCP server.

The BK9103 contains a 3-port switch. Two ports operate external on RJ45 connectors and can be utilised. 7 configured with a line topology instead of the classic star topology. In many applications this significantly r cabling costs. The maximum distance between two couplers is 100 m. Up to 20 BK9103 Bus Couplers are c length of 2 km can be achieved.

PROFINET is the open Industrial Ethernet standard of the PNO (PROFIBUS User Organisation). Internatic as TCP/IP are used for communication. PROFINET RT describes the data exchange between controllers an standard Ethernet networks. Commercial switches are used for networking purposes.

System data	PROFINET BK9103
Number of I/O stations	only limited by IP addresses
Number of I/O points	depending on controller
Data transfer medium	4 x 2 twisted pair copper cable; category 3 (10 Mbit/s), category 5 (100 Mbit/s)
Distance between stations	100 m between hub/switch and Bus Coupler or between Bus Coupler and Bus
Data transfer rates	100 MBit/s

Topology	line or star wiring
Cascading	up to 20 BK9103 or max. line length 2 km
<hr/>	
Technical data	BK9103
Number of Bus Terminals	64 (255 with K-bus extension)
Max. number of bytes fieldbus	512 byte input and 512 byte output
Digital peripheral signals	512 inputs/outputs
Analog peripheral signals	256 inputs/outputs
Protocol	PROFINET RT (Class B)
Configuration possibility	via KS2000
Data transfer rates	10/100 Mbit/s, automatic recognition of the transmission rate
Bus interface	2 x RJ45 (2-channel switch)
Power supply	24 V DC (-15 %/+20 %)
Input current	70 mA + (total K-bus current)/4, 500 mA max.
Starting current	2.5 x continuous current
Recommended fuse	≤ 10 A
Current supply K-bus	1750 mA
Power contacts	max. 24 V DC/max. 10 A
Electrical isolation	500 V (power contact/supply voltage/fieldbus)
Weight	approx. 170 g
Operating/storage temperature	-25...+60 °C/-40...+85 °C
Relative humidity	95 %, no condensation
Vibration/shock resistance	conforms to EN 60068-2-6/EN 60068-2-27
EMC immunity/emission	conforms to EN 61000-6-2/EN 61000-6-4
Protect. class/installation pos.	IP 20/variable
Approvals/Markings	CE, UL, ATEX, GL
<hr/>	
Accessories	
TS6271	license for using the TwinCAT PROFINET RT Controller
KS2000	configuration software for extended parameterisation
Cordsets	cordsets and connectors
FC9001-0010 FC9011	Ethernet PCI fieldbus cards
<hr/>	
Related products	
BK9053	PROFINET “Compact” Bus Coupler for up to 64 Bus Terminals (255 with K
CX8093	PROFINET Embedded PC
<hr/>	
System	
PROFINET	For further PROFINET products please see the system overview