

Bulletin 1606 Switched Mode Power Supplies

Catalog Number: 1606-XLE960DX-3N

Index

	Page
1. Description	1
2. Specification Quick Reference	1
3. Catalog Numbers	1
4. Certification Marks	1
5. AC Input	3
6. Input Inrush Current	4
7. Output	5
8. Hold-up Time	6
9. Efficiency and Power Losses.....	7
10. Functional Diagram.....	8
11. Front Side and User Elements.....	8
12. Terminals and Wiring.....	9
13. Reliability	9
14. EMC	10
15. Environment	11
16. Protection Features	12
17. Safety Features	12
18. Dielectric Strength	12
19. Certifications	13
20. Environmental Compliance	13
21. Physical Dimensions and Weight	14
22. Installation and Operating Instructions	14
23. Accessories	15
24. Comparison between the 1606-XLE960DX-3N, a Transformer and a Traditional Switched- Mode Power Supply	15
25. Application Notes	16
25.1. Periodic Peak Power Capability	16
25.2. Charging Batteries	16
25.3. Output Circuit Breakers	17
25.4. External Input Protection	18
25.5. Back-Feeding Loads	18
25.6. Parallel Use to Increase Output Power	18
25.7. Parallel Use for Redundancy	18
25.8. Series Operation	19
25.9. Inductive and Capacitive Loads	19
25.10. Loss of One Input Phase	19
25.11. Use in a Tightly Sealed Enclosure	19
25.12. Mounting Orientations	20

Terminology and Abbreviations

- **PE and \oplus symbol**—PE is the abbreviation for **Protective Earth** and has the same meaning as the symbol \oplus .
- **Earth, Ground**—This document uses the term “earth” which is the same as the U.S. term “ground”.
- **T.b.d.**—To be defined, value or description will follow later.
- **3AC 400V**—A figure displayed with the AC or DC before the value represents a nominal voltage with standard tolerances (usually $\pm 15\%$) included. 3AC means three phase input. E.g.: DC 12V describes a 12V battery disregarding whether it is charged (13.7V) or discharged (10V). If not otherwise stated, 3AC 400V parameters are valid at 50Hz and 3AC 480V parameters are valid at 60Hz mains frequency.
- **3x 400Vac**—A figure with the unit (Vac) at the end is a value used during testing without any additional tolerance included. 3x 400Vac means a three phase input.



Semi-Regulated Power Supply

- Alternative or Replacement for AC Transformer
- Three Phase Input – DC Output
- Mountable on a Din Rail
- Width only 96mm
- 95.5% Efficiency
- 125% Peak Power Capability
- No Input Inrush Current
- Active Input Transient Blocker
- Full Power Between -25°C and +60°C
- Easy Failure Diagnostics
- No Electrolytic Capacitors on Input Side
- Cost Effective and Robust
- 3 Year Warranty

1. Description

The power supplies in the three-phase (-3) series feature a new and innovative concept for generating an isolated DC voltage from a three-phase mains system.

A semi-regulated resonant converter enables a very compact design, maximum efficiency and extremely competitive pricing with only a small compromise in the output voltage regulation, output ripple and hold-up time.

Weighing just 1.4 kg, the device provides 960 watts of continuous output power and an additional 25% power reserve for dynamic loads. The light-weight design along with compact dimensions facilitate straightforward mounting on DIN rail.

Primary use are applications involving supplies to motors, valves and other load circuits with a high power consumption, where an accurate output voltage regulation which is standard on traditional switched-mode power supplies is not required. Furthermore, these switched-mode power supplies can often replace mains transformers with rectifiers.

2. Specification Quick Reference

Output voltage	DC 24V	Factory setting to 24.1V
Adjustment range	none	
Output current	40A 50A	continuous for typ. 15s
Output power	960W 1200W	continuous for typ. 15s
Output ripple	< 1500mVpp < 200mVpp	20Hz-2kHz 2kHz to 20MHz
Input voltage	3AC 480V	1606-XLE960DX-3N
Mains frequency	50-60Hz	±6%
AC Input current	1.4A / phase	3x480V
Power factor	0.93	24V, 40A
AC Inrush current	typ. 2A peak	
Efficiency	95.5%	
Losses	45.2W	
Temperature range	-25°C to +70°C	operational
Derating	24W/°C	+60 to +70°C
Dimensions	96x124x159mm	WxHxD

3. Catalog Numbers

Power Supply 1606-XLE960DX-3N 480V Input

Accessory 1606-XLSBUFFER24 24V Buffer Unit

4. Certification Marks



Intended Use

- This device is designed for installation in an enclosure and is intended for the general professional use such as in industrial control, office, communication, and instrumentation equipment.
- Do not use this power supply in aircraft, trains, nuclear equipment or similar systems where malfunction may cause severe personal injury or threaten human life.
- This device is designed for use in non-hazardous, ordinary or unclassified locations.

Installation Requirements

- This device may only be installed and put into operation by qualified personnel.
- This device does not contain serviceable parts. The tripping of an internal fuse is caused by an internal defect.
- If damage or malfunction should occur during installation or operation, immediately turn power off and send unit to the factory for inspection.
- Mount the unit on a DIN rail so that the terminals are located on the bottom of the unit. For other mounting orientations, refer to section 25-14 in this document.
- This device is designed for convection cooling and does not require an external fan. Do not obstruct airflow and do not cover ventilation grid (e.g. cable conduits) by more than 30%!
- Keep the following installation clearances: 40mm on top, 20mm on the bottom, 5mm on the left and right sides are recommended when the device is loaded permanently with more than 50% of the rated power. Increase this clearance to 15mm in case the adjacent device is a heat source (e.g. another power supply).

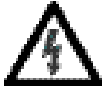

SHOCK HAZARD: Do not use the power supply without proper grounding (Protective Earth). Use the terminal on the input block for earth connection and not one of the screws on the housing.

- Turn power off before working on the device. Protect against inadvertent re-powering
- Make sure that the wiring is correct by following all local and national codes
- Do not modify or repair the unit
- Do not open the unit as high voltages are present inside
- Use caution to prevent any foreign objects from entering the housing
- Do not use in wet locations or in areas where moisture or condensation can be expected
- Do not touch during power-on, and immediately after power-off. Hot surfaces may cause burns.



WARNING: EXPLOSION HAZARDS!

Substitution of components may impair suitability for this environment. Do not disconnect the unit or operate the voltage adjustment or S/P jumper unless power has been switched off or the area is known to be non-hazardous.

5. AC-Input

1606-XLE960DX-3N

AC input	nom.	3AC 480V	
Mains arrangement		TN-, TT- or IT-Mains. Consult factory if one phase is grounded.	
AC input range	min.	3x 432-528Vac	fully regulated output ($\pm 2\%$), $P_{out} > 48W$
	min.	3x 360-552Vac	permanently allowed, see Fig. 5-1 for output voltage regulation
	max.	3x 565Vac	Absolute maximum input voltage with no damage to the power supply. Output might be off at this level.
Input frequency	nom.	50 – 60Hz	$\pm 6\%$
Turn-on voltage	typ.	3x 390Vac	see Fig. 5-2
Shut-down voltage	typ.	3x 355Vac	see Fig. 5-2
Input current	nom.	1.4A	at 40A, symmetrical input, see Fig. 5-4
Power factor (**)	typ.	0.93	at 40A, symmetrical input, see Fig. 5-5
Turn-on overshoot	typ.	480mV	see Fig. 5-3
Start-up delay (***)	typ.	350ms	over the entire load range, see Fig. 5-3
Rise time	typ.	40ms	0mF, 40A, see Fig. 5-3
	typ.	70ms	40mF, 40A, see Fig. 5-3

*) A minimum voltage of 3x408Vac is required to turn the power supply on.

**) The power factor is the ratio of the true (or real) power to the apparent power in an AC circuit.

***) The start-up delay for mains voltage interruptions up to 350ms is close to zero. In such cases, the power supply will immediately generate the output voltage once the mains voltage interruption is over. Do not use the 1606-XLSBUFFER24 buffer module as an accessory when longer mains interruptions need to be bridged (see section 23).

Input Voltage Range

Changes of the input voltage will be fully regulated within certain limits. The output voltage will only start to change proportionally to the input voltage with extreme under or over-voltages. The yellow LED reports an input voltage problem if exceeded by a window of $\pm 15\%$. The maximum increase of the output voltage is limited to the 29.9V OVP level. This level will be kept regulated for 2s before the power supply will shut down and reports "Shut-down" by the red LED.

Fig. 5-1 Output voltage vs. input voltage and input current

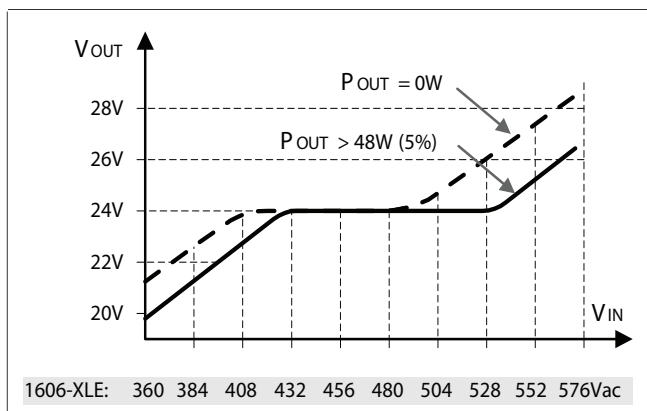

Fig. 5-2 Input Voltage Range

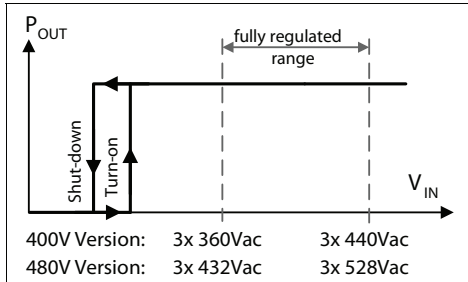

Fig. 5-3 Turn-on behavior definitions

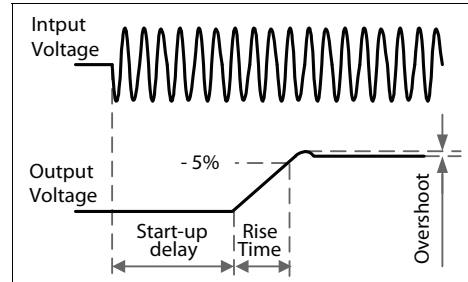

Fig. 5-4 Input current vs. output load

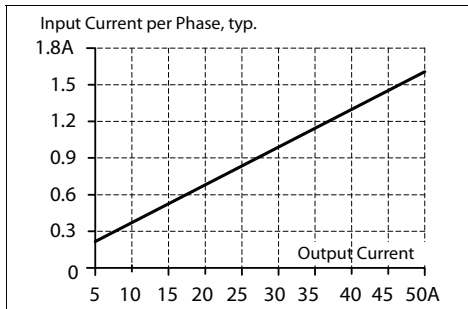
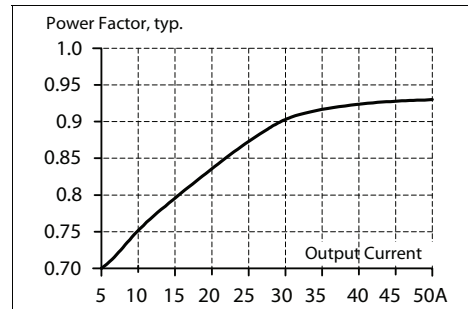

Fig. 5-5 Power factor vs. output load



6. Input Inrush Current

There is virtually no input inrush current surge as there are no electrolytic bulk-capacitors used on the input side of the power supply.

The charging current into the EMI suppression capacitors is disregarded for the first millisecond after switch-on.

1606-XLE960DX-3N

Inrush current	max.	4A _{peak}	-25°C to +70°C, see Fig. 6-1
Inrush energy	max.	5A ² s	-25°C to +70°C, see Fig. 6-1
Inrush delay	typ.	350ms	see Fig. 6-1

Fig. 6-1 Input inrush current

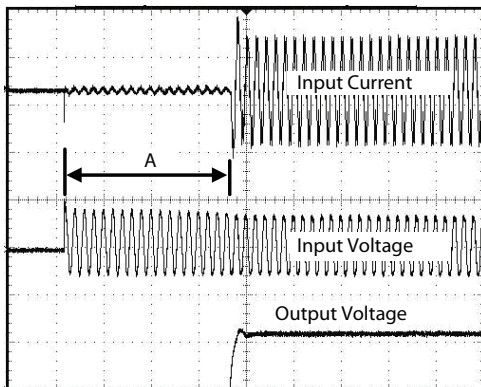

7. Output

Output voltage	nom.	24.1V	
Output voltage adjustment range		none	The output voltage is fixed. No adjustment possible.
Output current	nom.	40A 50A	continuous, see Fig. 7-1 up to 15s with full output voltage, see Fig. 7-1
Short-circuit current	typ.	180A	load impedance 25mOhm, see Fig. 7-1 Note: The short-circuit current is available for 0.1s.
Output power	nom.	960W 1200W	continuous up to 15s
Line regulation	max.	±2%	see Fig. 5-1
Load regulation	max.	800mV 200mV	static value, 0A → 40A → 0A static value, 5A → 40A → 5A
Ripple and noise voltage *)	max.	1500mVpp 50mVpp	20Hz-2kHz, 50Ohm 2kHz to 20MHz, 50Ohm
Output capacitance	typ.	20 000µF	

*) The ripple and noise voltage mostly consist of a mains ripple with 300Hz (50Hz mains) or 360Hz (60Hz mains). The ripple and noise voltage can be reduced by using external capacitors.

The power supply is also designed to support loads with a higher short-term current and power requirement. The short-term duration is firmware-controlled by an output power manager. If the nominal output power is exceeded for a certain period of time which is defined in zone A, B and C, the power supply responds with an automatic shut-down. Pressing the reset button or cycling the input power (10s off time is required) initiates a restart attempt. If the fault has been cleared the device will operate normally.

The short term power can be used periodically. See section 25.1 for further information.

Fig. 7-1 Output voltage vs. output current, typ.

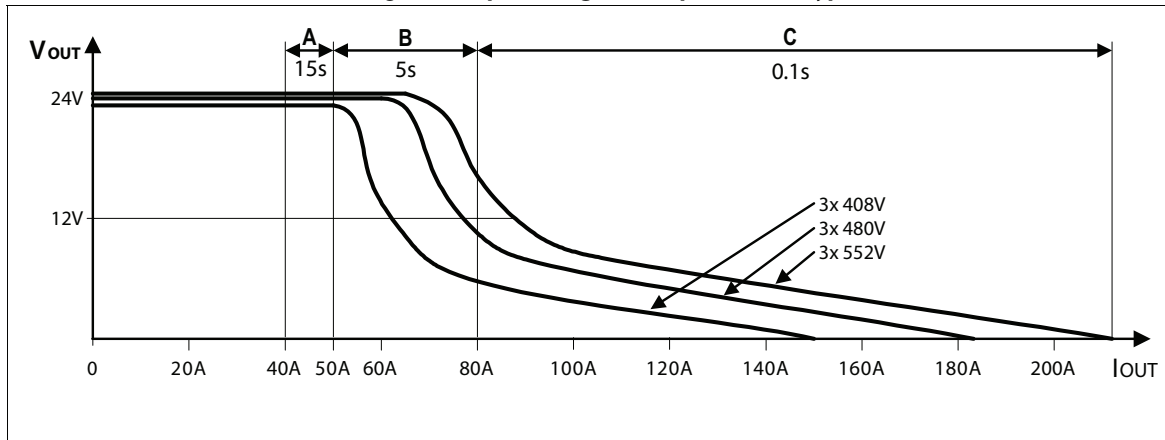

Zone A: 25% extra output power for typ. 15s

Zone B: 100% higher output current for typ. 5s

Zone C: Quick-acting shut-down after typ. 0.1s

8. Hold-up Time

1606-XLE960DX-3N

Hold-up Time	typ.	2.0ms	40A, resistive load, see Fig. 8-2
	typ.	1.8ms	40A, constant power load, see Fig. 8-2
	typ.	4.0ms	20A, resistive load
	typ.	3.6ms	20A, constant power load
Hold-up Time	min.	1.6ms	40A, resistive load, see Fig. 8-2
	min.	1.45ms	40A, constant power load, see Fig. 8-2
	min.	3.2ms	20A, resistive load
	min.	2.9ms	20A, constant power load

The energy is stored in the output capacitor. As soon as the input is turned off, the output capacitor will be discharged and the voltage will dissipate according to the curves in Fig 8-2. The lighter the load, the longer the hold-up time. Half the load means twice the hold-up time. The hold-up time depends on the load characteristic. The curves below show the hold-up time for a load with a resistive and a constant power characteristic. The hold-up time is defined as the period of time when the input is turned off and until the output voltage falls below 24V -15% (20.4V). This value is defined in the IEC61131-2 as the lower limit for the supplying voltage.

Fig. 8-1 Hold-up time, definitions

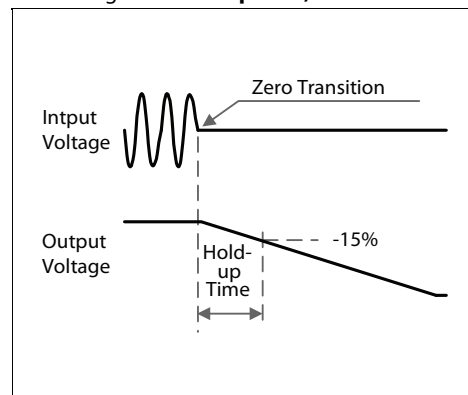
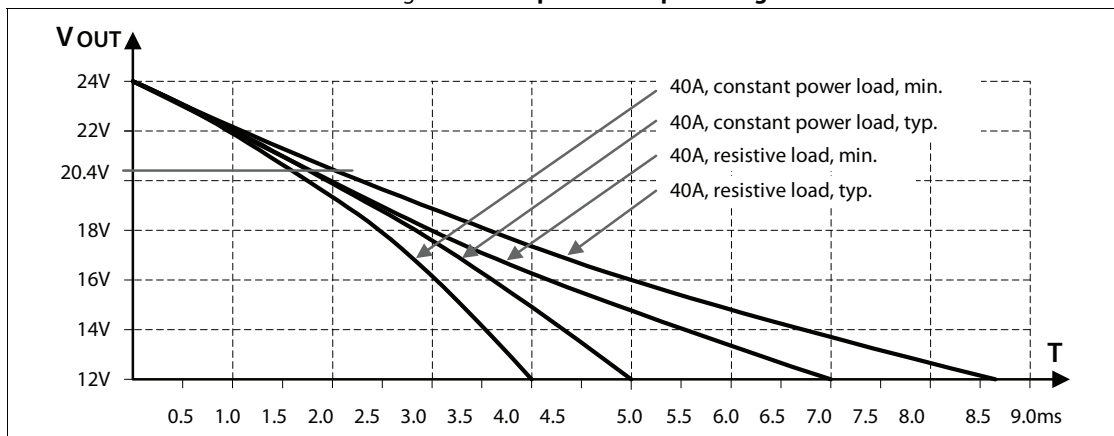

Fig. 8-2 Hold-up time vs. input voltage



Note: At no load, the hold-up time can be up to one minute. The green DC-ok LED is on at this time.

9. Efficiency and Power Losses

1606-XLE960DX-3N

Efficiency	typ.	95.5%	40A
Power losses	typ.	45.2W	40A
	typ.	18.2W	0A

Fig. 9-1 Efficiency vs. output current

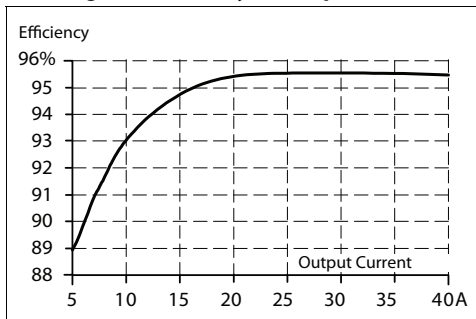

Fig. 9-2 Losses vs. output current

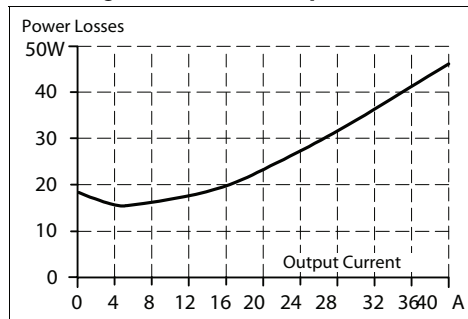

Fig. 9-3 Efficiency vs. input voltage, 24V, 40A

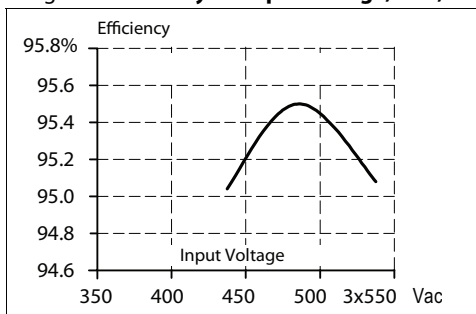
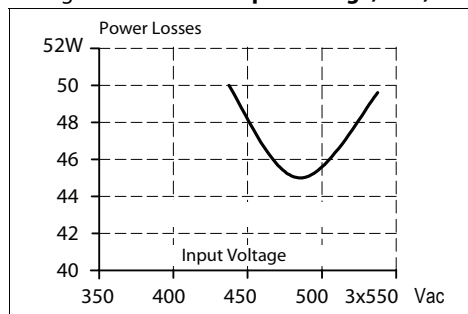
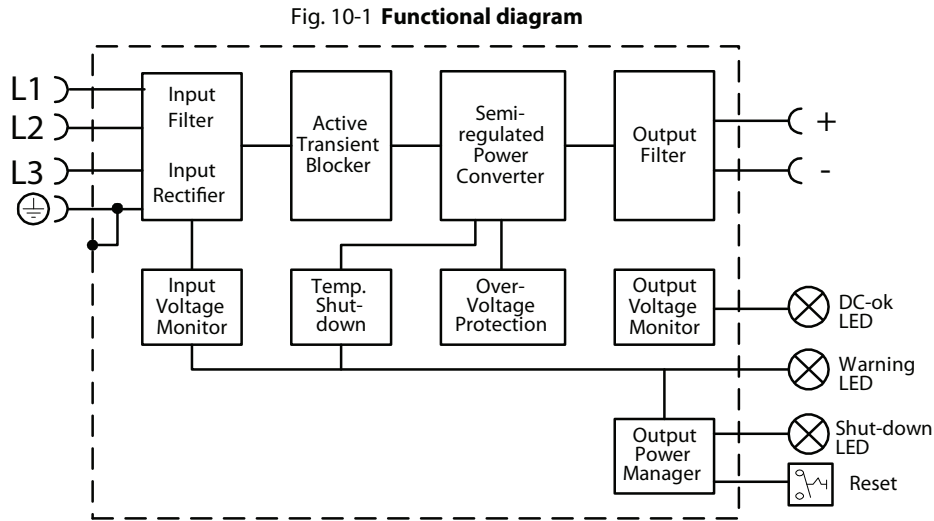

Fig. 9-4 Losses vs. input voltage, 24V, 40A



10. Functional Diagram



11. Front Side and User Elements

Fig. 11-1 **Front side of 1606-XLE960DX-3N**

A. Output Terminals

Large screw terminal

- + Positive output
- Negative (return) output

See section 12 "Terminals and Wiring" to choose appropriate wire size.

B. Input Terminals

Screw terminals

L1, L2, L3:

Line inputs

⊕ PE (Protective Earth) input

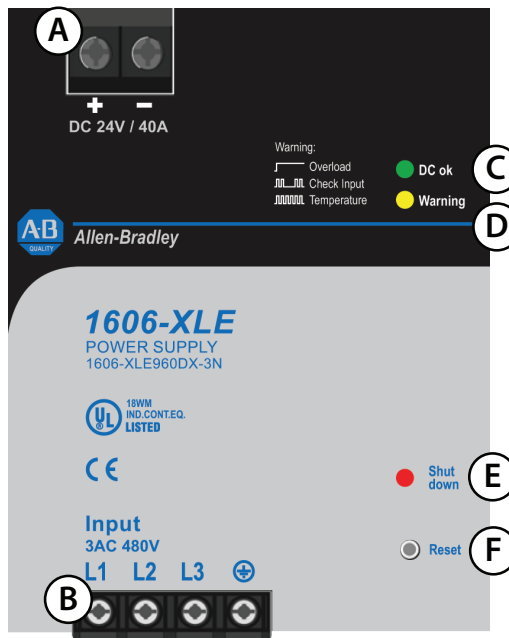

C. DC-ok LED (green)

Indicates a normal operation. The LED is on if the output voltage is higher than 21.6V.

D. Warning LED (yellow)

- A steady-state light indicates an output current higher than the nominal current and that the internal shutdown timer is running.
- A double flash indicates a phase-loss or too low / too high input voltage. (1606-XLE960DX-3N: < 3x400Vac or > 3x560Vac)
- A fast flash warns of an impending temperature shut-down. A shut-down can be expected within 10 minutes, if the ambient temperature or the load current stays constant.

E. Shut-down LED (red) and reset button F.

The red LED flashes when the device has shut down. Pressing the reset button or cycling the input power (10s required) initiates a restart. If the fault has been cleared the device will operate normally.

12. Terminals and Wiring

Use appropriate copper cables that are designed for a minimum operating temperatures of 60°C (for ambient up to 45°C) and 75°C (for ambient up to 60°C). Follow national installation codes and regulations! Ensure that all strands of a stranded wire enter the terminal connection! Do not use the power supply without PE (Ground) connection! Up to two stranded wires with the same cross section are permitted in one connection point (except PE wire). Ferrules are allowed, but not required.

	Input	Output
Type	Screw terminal	Screw terminal
Solid wire	0.5-6mm ²	0.5-16mm ²
Stranded wire	0.5-4mm ²	0.5-10mm ²
American wire gauge	20-10 AWG	22-8 AWG
Wire stripping length	7mm / 0.26inch	12mm / 0.5inch
Recommended tightening torque	0.8Nm / 7lb.inch	1.2Nm / 10.6lb.inch

13. Reliability

Lifetime expectancy	min.	51 000h	40°C, 24.1V, 40A
	min.	142 000h	25°C, 24.1V, 40A
MTBF SN 29500, IEC 61709		529 000h	40°C, 24.1V, 40A
		959 000h	25°C, 24.1V, 40A
MTBF MIL HDBK 217F		206 000h	40°C, 24.1V, 40A, Ground Benign GB40
		276 000h	25°C, 24.1V, 40A, Ground Benign GB25

The **Lifetime expectancy** shown in the table above indicates the operating hours (service life) and is determined by the lifetime expectancy of the built-in electrolytic capacitors.

Lifetime expectancy is specified in operational hours and is calculated according to specifications from the manufacturer of the capacitor. The prediction model allows a calculation up to 15 years from the shipping date.

MTBF stands for **Mean Times Between Failures** which is calculated according to statistical device failures, and indicates reliability of a device. It is the statistical representation of the likelihood of failure of the unit, and does not necessarily represent the life of a product.

14. EMC

The power supply is suitable for applications in industrial environments as well as in residential, commercial and light industry environment without any restriction. The CE Mark indicates conformance with EMC guideline 89/336/EC, 93/68/EC and the low-voltage directive (LVD) 73/23/EC, 93/68/EC and 2006/95/EC.

A detailed EMC Report is available upon request.

EMC Immunity	EN 61000-6-1, EN 61000-6-2		Generic standards	
	Electrostatic discharge	EN 61000-4-2	Contact discharge Air discharge	8kV 15kV
Electromagnetic RF field	EN 61000-4-3	80MHz-1GHz	10V/m	Criterion A
Fast transients (Burst)	EN 61000-4-4	Input lines Output lines	4kV 4kV	Criterion A Criterion A
Surge voltage on input	EN 61000-4-5	L1 → L2, L2 → L3, L1 → L3 L1 / L2 / L3 → PE	2kV 4kV	Criterion A Criterion A
Surge voltage on output	EN 61000-4-5	+ → - + → - PE	500V 500V	Criterion A Criterion A
Conducted disturbance	EN 61000-4-6	0.15-80MHz	10V	Criterion A
Mains voltage dips	EN 61000-4-11	0% of 400Vac 40% of 400Vac 70% of 100Vac 0% of 480Vac 40% of 480Vac 70% of 480Vac	20ms 200ms 500ms 20ms 200ms 500ms	Criterion B Criterion C Criterion C Criterion B Criterion C Criterion C
Power transients	VDE 0160	over entire load range	1300V, 1.3ms	Criterion D

Criteria:

- A:** Power supply shows normal behavior within the defined limits.
- B:** During the mains voltage dip, the output voltage will decrease according to curves in the Hold-up Time section. Unit works in normal mode after the voltage dip. If criterion A is required, use one or two buffer modules in addition to the 1606-XLE960DX-3N supply.
- C:** Temporary loss of function is possible. Power supply may shutdown and restart by itself. No damage or hazard to the power supply occurs.
- D:** The input transient blocker opens and the main converter is without input power during such transients. The output voltage decreases as well, as described in the Hold-up Time section, during such an event.

EMC Emission	EN 61000-6-3 and EN 61000-6-4	Generic standards
Conducted emission	EN 55011, EN 55022, FCC Part 15, CISPR 11, CISPR 22 EN 55022	Class B, input lines Class B, output lines
Radiated emission	EN 55011, EN 55022	Class B
Harmonic input current	EN 61000-3-2	Fulfilled, active PFC
Voltage fluctuations, flicker	EN 61000-3-3	Fulfilled

This device complies with FCC Part 15 rules.

Operation is subjected to following two conditions: (1) this device may not cause harmful interference, and (2) this device must accept any interference received, including interference that may cause undesired operation.

Switching frequency

Switching frequency	36kHz	Nearly constant
---------------------	-------	-----------------

15. Environment

Operational temperature	-25°C to +70°C (-13°F to 158°F)	Reduce output power above +60°C
Output derating	24W/°C	60-70°C (140°F to 158°F), see Fig. 15-1
Storage temperature	-40 to +85°C (-40°F to 185°F)	storage and transportation
Humidity	5 to 95% r.H.	no condensation allowed
Vibration sinusoidal	2-17.8Hz: ±1.6mm; 17.8-500Hz: 2g 2 hours / axis	IEC 60068-2-6
Vibration random	0.5m ² (s ³) 2 hours / axis	IEC 60068-2-64
Shock	15g 6ms, 10g 11ms 3 bumps / direction, 18 bumps in total	IEC 60068-2-27
Altitude	0 to 6000m (0 to 20 000ft)	Reduce output power or ambient temperature above 2000m sea level.
Output derating (for altitude)	60W/1000m or 5°C/1000m	above 2000m, see Fig. 15-2.
Over-voltage category	III	EN 50178, altitudes up to 2000m
	II	Altitudes from 2000m to 6000m
Degree of pollution	2	EN 50178, non conductive

Fig. 15-1 **Output current vs. ambient temp.,**

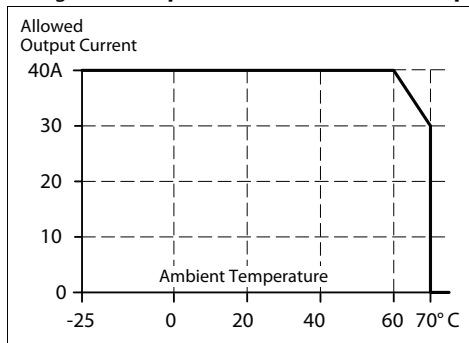
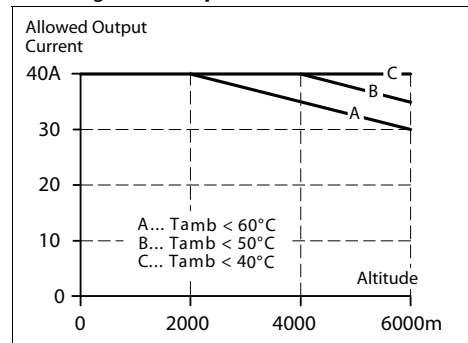

Fig. 15-2 **Output current vs. altitude**



The ambient temperature is defined 2cm below the unit.

16. Protection Features

Output protection	Electronically protected against overload, no-load and short-circuits *)	
Output overvoltage protection	max. 29.9Vdc	in case of an internal power supply defect, a redundant circuit limits the maximum output voltage. The output shuts down and automatically attempts to restart.
Input overvoltage shutdown	typ. 3x 560Vac	1606-XLE960DX-3N
Degree of protection	IP 20	EN/IEC 60529
Penetration protection	> 3.5mm	e.g. screws, small parts
Over-temperature protection	yes	output shut-down with automatic restart
Input transient protection	MOV (Metal Oxide Varistor) and active transient blocker	
Internal input fuse	not included	see section 25.4

*) An audible noise may be heard during a no-load, overload or short circuit event.

17. Safety

Input/output separation	SELV PELV double or reinforced insulation	IEC/EN 60950-1 EN 60204-1, EN 50178, IEC 60364-4-41
Class of protection	I	PE (Protective Earth) connection required
Isolation resistance	> 5M Ω m	input to output, 500Vdc
PE resistance	< 0.1 Ω m	between housing and PE terminal
Touch current (leakage current)	typ. 0.40mA < 0.45mA	13x480V, 60Hz, TN mains 3x524V, 60 Hz, TN mains

18. Dielectric Strength

Fig. 18-1 Dielectric strength

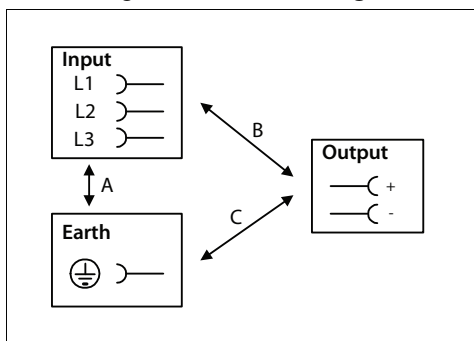

		A	B	C
Type test	60s	2500Vac	3000Vac	500Vac
Factory test	5s	2500Vac	2500Vac	500Vac
Field test	5s	2000Vac	2000Vac	500Vac

Type tests and factory tests:

Conducted by the manufacturer. Do not repeat these tests in the field!







Rules for field test:

Use appropriate test equipment which applies the voltage with a slow ramp! Connect L1, L2 and L3 together as well as all output poles.

The output voltage is floating and has no ohmic connection to ground. Grounding of output is allowed.

To fulfill the PELV requirements according to EN60204-1, paragraph 6.4.1, we recommend that either + pole or the - pole be connected to the protective earth system. This helps avoid situations in which a load starts unexpectedly or cannot be switched off when an unnoticed ground fault occurs.

19. Certifications

EN 60950-1, EN 61204-3		Complies with CE EMC and CE Low Voltage Directives
UL 508		LISTED E56639 for use in the U.S.A. (UL 508) and Canada (C22.2 No. 14-95)
UL 60950		RECOGNIZED E1168663 for use in the U.S.A. (UL 60950-1) and Canada (C22.2 No. 60950) Information Technology Equipment, Level 3
Marine RINA		RINA (Registro Italiano Navale) certified. See below for link to the Certificate.
GOST R		GOST R certification is applicable for products intended for sale and use within Russia. See below for link to the Certificate.
C-TICK		C-Tick compliance is for products intended for sale and use within the Australian market. See below for link to the C-Tick Declarations of Conformity.

Product certification information (including Certificates and Declarations of Conformity) can be found at www.ab.com/certifications.

20. Environmental Compliance

The unit does not release any silicone and is suitable for use in paint shops.

Electrolytic capacitors included in this unit do not use electrolytes such as Quaternary Ammonium Salt Systems.

Plastic housings and other molded plastic materials are free of halogens.

The materials used in our production process do not include the following toxic chemicals:
 Polychlorinated Biphenyl (PCB), Pentachlorophenol (PCP), Polychlorinated naphthalene (PCN), Polybrominated Biphenyl (PBB), Polybrominated Biphenyl Oxide (PBO), Polybrominated Diphenyl Ether (PBDE), Polychlorinated Diphenyl Ether (PCDE), Polybrominated Diphenyl Oxide (PBDO), Cadmium, Asbestos, Mercury, Silica

21. Physical Dimensions and Weight

Weight	1400g / 3.09lb
DIN Rail	Use 35mm DIN rails according to EN 60715 or EN 50022 with a height of 7.5 or 15mm. The DIN rail height must be added to the depth (157mm) to calculate the total required installation depth.

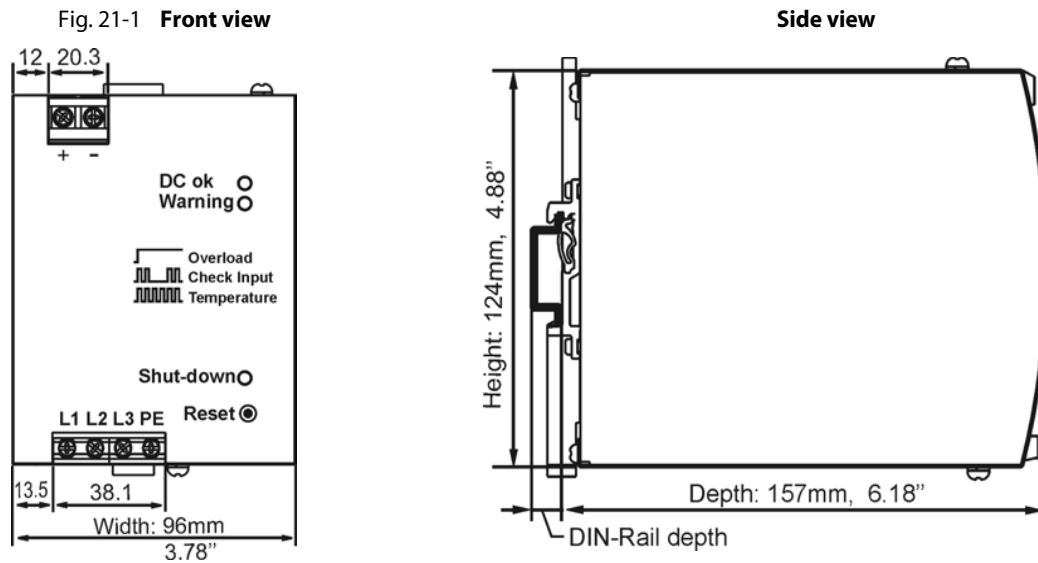

22. Installation and Operating Instructions

Mounting and installation:

Output terminal must be located on top and input terminal on the bottom. For other orientations see section 25.12. An appropriate electrical and fire end-product enclosure needs to be considered in the end use application.

Cooling:

Convection cooled, no forced air cooling required. Do not block ventilation grille by more than 30%!

Installation clearances:

40mm on top, 20mm on the bottom, 5mm on the left and right side are recommended when loaded permanently with full power. If the adjacent device is a heat source, 15mm clearance are recommended.

Risk of electrical shock, fire, personal injury or death!

Do not use the unit without proper earth connection (Protective Earth). Use the pin on the terminal block for earth connection and not one of the screws on the housing.

Turn power off before working on the power supply. Protect against inadvertent re-powering.

Make sure the wiring is correct by following all local and national codes.

Do not open, modify or repair the unit.

Use caution to prevent any foreign objects from entering the housing.

Do not use in wet locations or in areas where moisture and/or condensation are likely to occur.

Service parts:

The unit does not contain any field replaceable parts. In case of damage or malfunction, turn power off immediately and return the unit to the manufacturer for inspection.

23. Accessories

Buffer Module 1606-XLSBUFFER24

This buffer unit is a supplementary device for DC24V power supplies. It delivers power to bridge typical mains failures or extends the hold-up time after turn-off of the AC power. At times when the power supply provides sufficient voltages, the buffer unit stores energy in integrated electrolytic capacitors. In case of mains voltage fault, this energy is released again in a regulated process.

Fig. 23-1 Buffer module 1606-XLSBUFFER24



Fig. 23-2 Wiring diagram: 1606-XLSBUFFER24

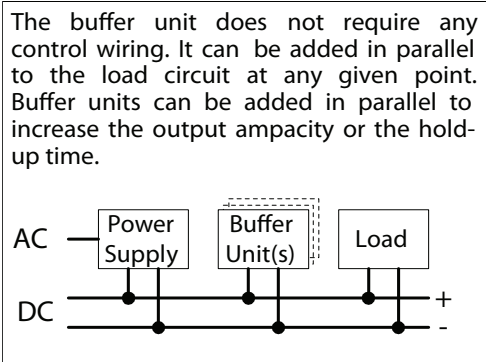

Do not use the buffer module to bridge mains interruptions which are longer than typ. 350ms. Once the mains is off for longer than typ. 350ms, the power supply needs an additional 1s to restart.

24. Comparison between the 1606-XLE960DX-3N, a Transformer and a Traditional Switched-mode Power Supply

	1606-XLE960DX-3N semi-regulated power supply	Traditional switched-mode power supply	Transformer power supply
Input voltage range	+	++	-
Inrush current surge	++	+	-
Hold-up time	-	+	-
Phase-loss operation	-	+	-
Efficiency	+++	++	-
Output voltage regulation	+	++	-
Output adjustment range	-	++	-
Ripple & noise voltage	-	++	-
Error diagnostics	++	++	-
Harmonic distortion (PFC)	+	+	-
EMC	++	++	+
Ease of installation	++	++	-
Size	+++	++	-
Weight	+++	+	-
	+++...very, very good	++...very good	+...good -...poor

All parameters are specified at 24V, 40A, 3x480Vac, 25°C ambient and after a 5 minutes run-in time, unless noted otherwise.

25. Application Notes

25.1. Periodic Peak Power Capability

The short term power can be used periodically.

The duration of the peak power (T_P) must be shorter than 15s.

The time between two peak power pulses must be three times longer than the duration of the preceding pulse length.

Fig. 26 **Periodic peak power capability**

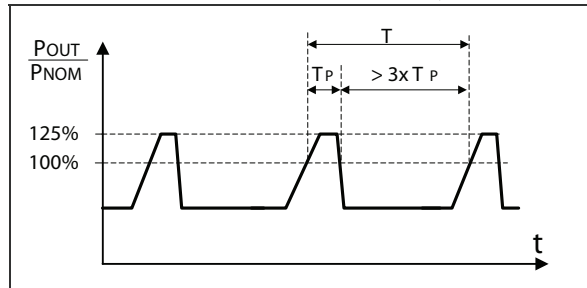

25.2. Charging Batteries

Do not use this power supply to charge batteries.

25.3. Output Circuit Breakers

Standard miniature circuit breakers (MCBs or UL 1077 supplementary breakers) can be used for branch protection but make sure that the MCB is rated for DC voltage as well. The following tests show which circuit breakers the power supply will typically trip.

Circuit breakers have huge tolerances in their tripping behavior. These typical tests can therefore be used only as a recommendation or for comparing two different power supplies. Furthermore, the loop impedance has a major influence on whether a breaker trips or not. Two tests were performed, representing typical situations:

Test 1: Short circuit with S1 on the power supply end of the cable (loop impedance approx. 20mOhm)

Fig. 25-1 Branch protectors, test circuit 1

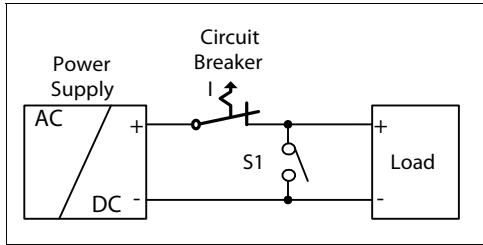

Parameters:

Input voltage: 3x400Vac, load current: 0A

The following circuit breaker tripped during the test:

- A- or Z-Characteristic:** equal or smaller 25A *)
- B- Characteristic:** equal or smaller 32A *)
- C- Characteristic:** equal or smaller 20A *)

Test 2: Short circuit with S1 on the load end (additional impedance included; represents longer load wire length).

Fig. 25-2 Branch protectors, test circuit 2

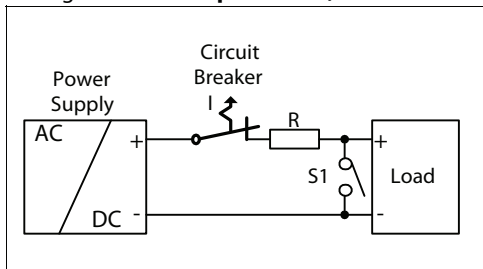

Parameters:

Input voltage: 3x400Vac, load current: 0A

The following circuit breaker tripped during the test:

- A- or Z-Characteristic:** ≤ 25A and R= 50mOhm *)
- B- Characteristic:** ≤ 25A and R= 50mOhm *)
- C- Characteristic:** ≤ 20A and R= 82mOhm *)

What does this resistance mean in wire length?

	1.0mm ²	1.5mm ²	2.5mm ²	4.0mm ²	6.0mm ²	10mm ²
50mOhm	2.8m	4.2m	7.0m	11.1m	16.7m	27.9m
82mOhm	4.6m	6.9m	11.4m	18.3m	27.4m	45.7m

*) A list of the circuit breakers under test is available upon request.

Example:

Which wire gauge must be used at a length of 10m before a B-Characteristic circuit breaker with 25A trips?

Answer: A 25A B-Characteristic circuit breaker requires a loop impedance of less than 50mOhm based on the test results. The wire length table shows that a length of 11.1m with a cross-section of 4.0mm² has an impedance of 50mOhm. A wire not smaller than 4.0mm² shall be used.

25.4. External Input Protection

The power supply has no internal input fuses included. The unit is tested and approved for branch circuits up to 16A (U.S.A. 15A). External protection is required only if the supplying branch has an ampacity greater than this. In some countries local regulations may apply; do check all local codes and requirements. If an external fuse is necessary or utilized, minimum requirements need to be considered to avoid nuisance tripping of the fuse.

		B-Characteristic	C-Characteristic
Ampacity	max.	20A	20A
	min.	6A	3A

25.5. Back-feeding Loads

Loads such as decelerating motors and inductors can feed voltage back to the power supply. This feature is also called return voltage immunity or resistance against Back-EMF (Electro Magnetic Force).

This power supply is resistant and does not show adverse effects when a load feeds back voltage to the power supply. It does not matter whether the power supply is on or off.

If the power supply is fully loaded after a return-feeding event, the output voltage can dip to 21V for approx. 20ms.

The maximum allowed feed back voltage is 28.9Vdc. The absorbing energy can be calculated according to the built-in large sized output capacitor which is specified in section 7.

25.6. Parallel Use to Increase Output Power

The 1606-XLE960DX-3N power supply shall not be used in parallel to increase output power.

25.7. Parallel Use for Redundancy

Power supplies can be paralleled for a 1+1 redundancy to gain a higher system availability and reliability. Redundant systems require a certain amount of extra power to support the load in case one power supply unit fails. The simplest way is to put two 1606-XLE power supplies in parallel (a method called 1+1 redundancy). In case one power supply fails, the second is automatically able to support the load current without any interruption.

Please note: This simple way to build a redundant system does not cover failures such as an internal short circuit on the secondary side of the power supply. In such a condition, the shorted unit becomes a load for the other power supplies and the output voltage can not be maintained. This can be avoided by using decoupling diodes which are included in some redundancy modules.

Recommendations for building redundant power systems:

- Use separate input fuses for each power supply.
- Monitor the individual power supply units. A DC-ok LED and a DC-ok contact are included in some redundancy modules and are able to report a faulty unit.

25.8. Series Operation

Power supplies from the 1606-XLE family can be used in series to increase output voltage.

Fig. 25-3 Schematic for series operation

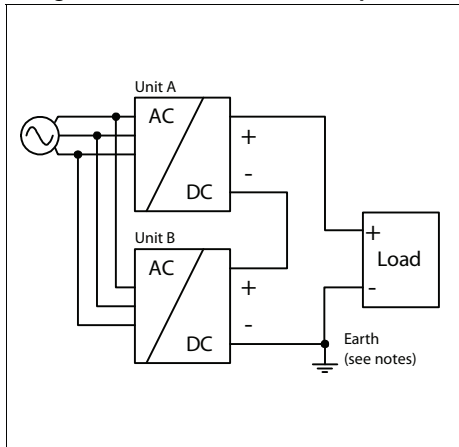

Installation notes for use in series:

- It is possible to connect as many units in series as needed, providing the sum of the output voltage does not exceed 150Vdc.
- Voltages with a potential above 60Vdc are no longer rated SELV and can be hazardous in some situations. Such voltages must be installed with a protection to make the unit touch-safe.
- For serial operation use power supplies of the same type.
- Earthing of the output is required when the sum of the output voltage is above 60Vdc.
- Keep an installation clearance of 15mm (left/right) between two power supplies and avoid installing the power supplies on top of each other.

Note: Avoid return voltage (e.g. from a decelerating motor or battery) which is applied to the output terminals.

25.9. Inductive and Capacitive Loads

The unit is designed to supply any kind of loads, including inductive loads or capacitive loads with a capacity of up to 160mF.

25.10. Loss of One Input Phase

The unit protects itself against a loss of one input phase and does not require an external protection device.

A phase-loss operation is possible for output currents below 8A. Above this level, the yellow LED indicates an impending shut-down. If the missing phase does not recover, the unit switches off after 3.5s. Pressing the reset button or cycling the input power (10s required) initiates a restart.

Please note that the input current and the output ripple are higher when one phase is missing.

25.11. Use in a Tightly Sealed Enclosure

When the power supply is installed in a tightly sealed enclosure, the temperature inside the enclosure will be higher than outside. The inside temperature defines the ambient temperature for the power supply.

Results from such an installation:

Power supply is placed in the middle of the box, no other heat producing equipment is inside the box.

Enclosure:	Rittal Typ IP66 Box PK 9519 100, plastic, 180x180x165mm
Load:	24V, 32A (=80% of the rated current); load is placed outside the box.
Input:	3x400Vac
Temperature inside the box:	54.9°C (in the middle of the right side of the power supply with a distance of 2cm)
Temperature outside the box:	25.7°C
Temperature rise:	29.7K

25.13. Mounting Orientations

Mounting orientations other than input terminals on the bottom and output on the top require a reduction in continuous output power or a limitation in the maximum allowed ambient temperature. The amount of reduction influences the lifetime expectancy of the power supply. Therefore, two different derating curves for continuous operation can be found below:

Curve A1 Recommended output current.

Curve A2 Max allowed output current (results in approximately half the lifetime expectancy of A1).

Fig. 25-4
Mounting Orientation A
(Standard orientation)

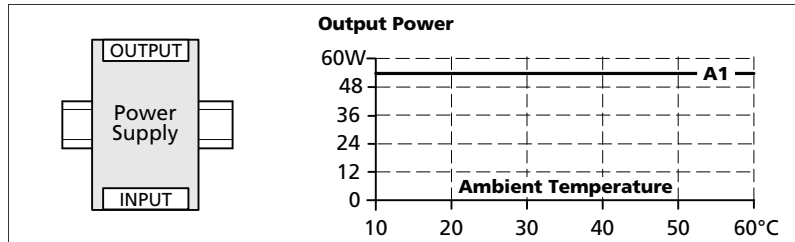

Fig. 25-5
Mounting Orientation B
(Upside down)

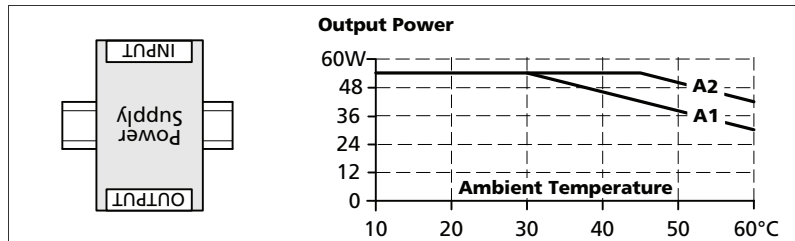

Fig. 25-6
Mounting Orientation C
(Table-top mounting)

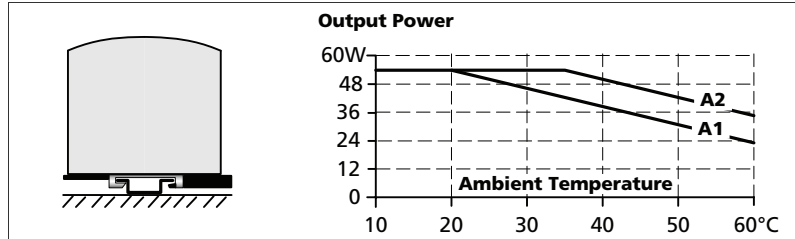

Fig. 25-7
Mounting Orientation D
(Horizontal cw)

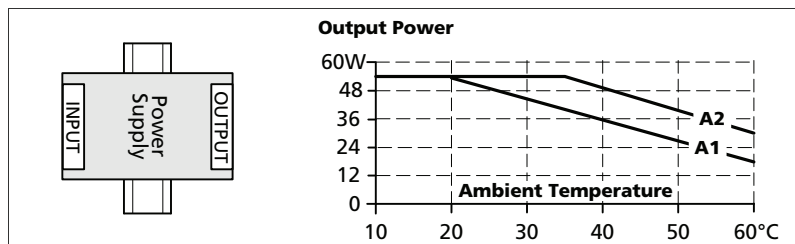
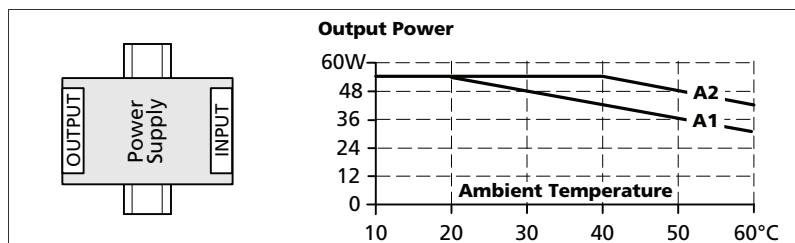

Fig. 25-8
Mounting Orientation E
(Horizontal ccw)



Rockwell Automation Support

Rockwell Automation provides technical information on the Web to assist you in using its products. At <http://www.rockwellautomation.com/support>, you can find technical manuals, technical and application notes, sample code and links to software service packs, and a MySupport feature that you can customize to make the best use of these tools. You can also visit our Knowledgebase at <http://www.rockwellautomation.com/knowledgebase> for FAQs, technical information, support chat and forums, software updates, and to sign up for product notification updates.

For an additional level of technical phone support for installation, configuration, and troubleshooting, we offer TechConnectSM support programs. For more information, contact your local distributor or Rockwell Automation representative, or visit <http://www.rockwellautomation.com/support/>.

Installation Assistance

If you experience a problem within the first 24 hours of installation, review the information that is contained in this manual. You can contact Customer Support for initial help in getting your product up and running.

United States or Canada	1.440.646.3434
Outside United States or Canada	Use the Worldwide Locator at http://www.rockwellautomation.com/rockwellautomation/support/overview.page , or contact your local Rockwell Automation representative.

New Product Satisfaction Return

Rockwell Automation tests all of its products to help ensure that they are fully operational when shipped from the manufacturing facility. However, if your product is not functioning and needs to be returned, follow these procedures.

United States	Contact your distributor. You must provide a Customer Support case number (call the phone number above to obtain one) to your distributor to complete the return process.
Outside United States	Please contact your local Rockwell Automation representative for the return procedure.

Documentation Feedback

Your comments will help us serve your documentation needs better. If you have any suggestions on how to improve this document, complete this form, publication [RA-DU002](#), available at http://literature.rockwellautomation.com/idc/groups/literature/documents/du/ra-du002_-en-e.pdf.

www.rockwellautomation.com

Power, Control and Information Solutions Headquarters

Americas: Rockwell Automation, 1201 South Second Street, Milwaukee, WI 53204-2496 USA, Tel: (1) 414.382.2000, Fax: (1) 414.382.4444
Europe/Middle East/Africa: Rockwell Automation NV, Pegasus Park, De Kleetlaan 12a, 1831 Diegem, Belgium, Tel: (32) 2 663 0600, Fax: (32) 2 663 0640
Asia Pacific: Rockwell Automation, Level 14, Core F, Cyberport 3, 100 Cyberport Road, Hong Kong, Tel: (852) 2887 4788, Fax: (852) 2508 1846