

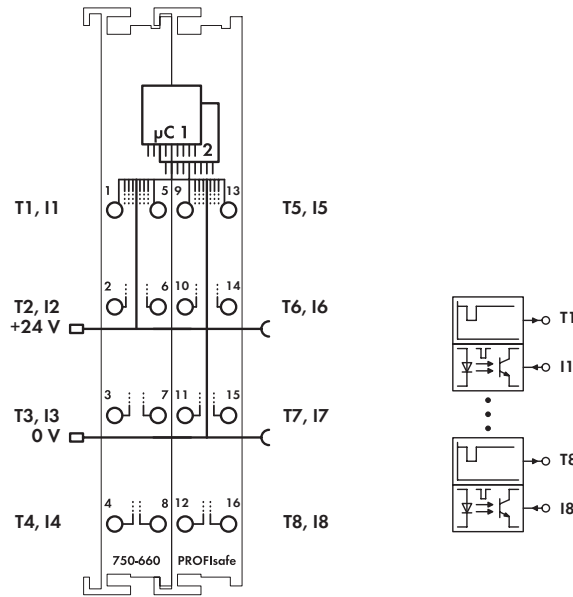

8-Channel Digital Input Module PROFI-safe V1.3

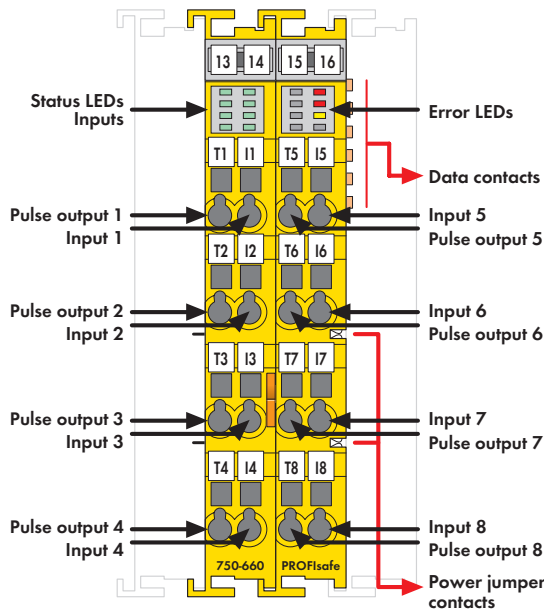

Emergency stop buttons, limit indicators, or other safe-contact sensors may be connected to the 750-660/000-001 PROFI-safe Input Module. The module has 8 pulse inputs (I1 ... I8) that are supplied by 8 different pulse outputs (T1 ... T8). The pulse outputs are short circuit proof. The inputs are constantly monitored for short circuits and supply voltage from separate sources. A green LED for each of the 8 input channels indicates the signal state, 2 red LEDs indicate internal or external errors. The address switch at the side of the module is used to set the PROFI-safe address. The fieldside and internal system are electrically isolated.

Any configuration of the input modules is possible when designing the fieldbus node. Grouping of module types is not necessary. A fieldbus node comprised of PROFI-safe devices must be supplied by a filtered power supply (PELV/SELV power supply unit). Reference the product manual for further information.

When implementing new installations, please consider PROFI-safe V2 iPar 750-662/000-003 8-Channel Digital Input Safety Module (see page 299).

Description	Item No.	Pack. Unit
8FDI 24V DC PROFI-safe V1.3	750-660/000-001	1
Accessories		
Miniature WSB Quick marking system		
 plain	248-501	5
with marking	see pages 352 ... 353	
Standards and Approvals		
Basic standard safety applications	Also see "Approvals Overview" in Section 1	
Conformity marking	CE	
UL 508	Class I, Div. 2, Grp. ABCD, T4	
ANSI/ISA 12.12.01	I M2 / II 3 GD Ex nA nL IIC T4	
EN 60079-0, -15		
EN 61241-0, -1		

Technical Data	
Inputs	I1 ... I8; pulse inputs
Achievable safety classes	8 x Cat. 2/SIL 2 or 4 x Cat. 4/SIL 3
Outputs	T1 ... T8: 8 pulse outputs, short circuit proof
Voltage via power jumper contacts	24 V DC (-15 % ... +20 %)
Current via power jumper contacts (max.)	10 A DC
Response times (min ... max)	t _{on} (H->L) = 13 ms ... 71 ms t _{off} (H->L) = 13 ms ... 26 ms plus 2 x runtime internal bus plus 2 x runtime coupler - PLC plus runtime PLC
Proof test interval	10 years
Wire connection	CAGE CLAMP®
Cross sections	0.08 mm² ... 2.5 mm² / AWG 28 ... 14
Stripped lengths	8 ... 9 mm / 0.33 in
Width	24 mm
Weight	97 g
EMC CE-Immunity to interference	acc. to EN 61000-6-2 (2005)
EMC CE-Emission of interference	acc. to EN 61000-6-4 (2007)