

Incremental encoders

Compact plastic housing, optical

3700 / 3720 (shaft / hollow shaft)

Push-pull / RS422



The incremental economy encoders type 3700 / 3720 with optical sensor technology are a particularly compact and economical solution.

The carbon-fiber reinforced plastic housing of these incremental encoders is, nevertheless, extremely robust and resistant.



Magnetic field proof



Reverse polarity protection



Short-circuit proof



High protection level



Optical sensor

Reliable

- Tube Tech® cable outlet with extremely high strain relief.
- Ideal for outdoor use thanks to high IP protection.

Versatile

- Through hollow shaft up to 8 mm.
- Compact size of only 37 mm.
- Up to 1024 pulses per revolution.

Order code Shaft version

8.3700 . **XXXX** . **XXXX**
Type a b c d e

a Flange

- 1 = clamping-synchro flange, \varnothing 36.8 mm [1.45"]
- A = flange adapter, mounted, \varnothing 40 mm [1.57"]²⁾

b Shaft with flat, \varnothing x L²⁾

- 1 = \varnothing 4 x 12.5 mm [0.16 x 0.49"]
- 2 = \varnothing 5 x 12.5 mm [0.20 x 0.49"]
- 3 = \varnothing 6 x 12.5 mm [0.24 x 0.49"]
- 6 = \varnothing 8 x 12.5 mm [0.32 x 0.49"]
- 4 = \varnothing 1/4" x 12.5 mm [1/4" x 0.49"]

c Output circuit / power supply

- 1 = RS422 / 5 V DC (\pm 5 %)
- 3 = push-pull (with inverted signal) / 5 ... 30 V DC
- 4 = push-pull (with inverted signal) / 10 ... 30 V DC

d Type of connection¹⁾

- 1 = axial cable, 1 m [3.28'] PVC
- 2 = radial cable, 1 m [3.28'] PVC
- 3 = axial cable, 2 m [6.56'] PVC
- 4 = radial cable, 2 m [6.56'] PVC
- 5 = axial cable, 3 m [9.84'] PVC
- 6 = radial cable, 3 m [9.84'] PVC
- 7 = axial cable, 5 m [16.40'] PVC
- 8 = radial cable, 5 m [16.40'] PVC

e Pulse rate

- 10, 25, 50, 60, 100, 200, 250, 300, 360, 400, 500, 512, 600, 1000, 1024 (e.g. 360 pulses => 0360)

Stock types

- 8.3700.1332.0360
- 8.3700.1332.0500
- 8.3700.1332.1000
- 8.3700.1332.1024

Optional on request

- other pulse rates

Order code Hollow shaft

8.3720 . **XXXX** . **XXXX**
Type a b c d e

a Flange

- 1 = with spring element, short
- 2 = with spring element, long
- 5 = with stator coupling, \varnothing 46 mm [1.81"]

b Through hollow shaft

- 1 = \varnothing 4 mm [0.16"]
- 2 = \varnothing 5 mm [0.20"]
- 3 = \varnothing 6 mm [0.24"]
- 6 = \varnothing 8 mm [0.32"]
- 4 = \varnothing 1/4"

c Output circuit / power supply

- 1 = RS422 / 5 V DC (\pm 5 %)
- 3 = push-pull (with inverted signal) / 5 ... 30 V DC
- 4 = push-pull (with inverted signal) / 10 ... 30 V DC

d Type of connection¹⁾

- 1 = radial cable, 1 m [3.28'] PVC
- 2 = radial cable, 2 m [6.56'] PVC
- 3 = radial cable, 3 m [9.84'] PVC
- 4 = radial cable, 5 m [16.40'] PVC

e Pulse rate

- 10, 25, 50, 60, 100, 200, 250, 300, 360, 400, 500, 512, 600, 1000, 1024 (e.g. 360 pulses => 0360)

Stock types

- 8.3720.5631.0360
- 8.3720.5611.1024

Optional on request

- other pulse rates

1) "Tube Tech®" cable outlet guarantees 10 x higher strain relief than traditional cabling methods plus higher IP protection.

2) With flange adapter L = 8.9 mm [0.35"].

Incremental encoders

Compact plastic housing, optical	3700 / 3720 (shaft / hollow shaft)	Push-pull / RS422
---	---	--------------------------

Mounting accessory for shaft encoders		Order no.
Coupling	bellows coupling \varnothing 15 mm [0.59"] for shaft 6 mm [0.24"]	8.0000.1202.0606

Further accessories can be found in the accessories section or in the accessories area of our website at: www.kuebler.com/accessories.
Additional connectors can be found in the connection technology section or in the connection technology area of our website at: www.kuebler.com/connection_technology.

Technical data

Mechanical characteristics		
Maximum speed		6000 min ⁻¹
Mass moment of inertia	shaft version	approx. 0.4×10^{-6} kgm ²
	hollow shaft version	1.4×10^{-6} kgm ²
Starting torque - at 20°C [68°F]		
	shaft version	< 0.007 Nm
	hollow shaft version	< 0.01 Nm
Shaft load capacity	radial	20 N
	axial	10 N
Weight		approx. 0.1 kg [35.27 oz]
Protection acc. to EN 60529		
	bearings, shaft	IP65
	cable outlet	IP67
Working temperature range		-20°C ... +70°C [-4°F ... 158°F] ¹⁾
Materials	shaft / hollow shaft	stainless steel
	housing, flange	plastic PPA, 40 % CF (carbon fiber)
	cable	PVC
Shock resistance acc. to EN 60068-2-27		1000 m/s ² , 6 ms
Vibration resistance acc. to EN 60068-2-6		100 m/s ² , 10 ... 2000 Hz

Electrical characteristics			
Output circuit	RS422 (TTL compatible)	Push-pull (7272 comp.) ⁴⁾	Push-pull (7272 comp.) ⁴⁾
Power supply	5 V DC ($\pm 5\%$)	5 ... 30 V DC	10 ... 30 V DC
Power consumption with inverted signal (no load)	typ. 40 mA max. 90 mA	typ. 50 mA max. 100 mA	typ. 50 mA max. 100 mA
Permissible load / channel	max. +/- 20 mA	max. +/- 20 mA	max. +/- 20 mA
Pulse frequency	max. 250 kHz	max. 250 kHz	max. 250 kHz
Signal level	HIGH	min. 2.5 V	min. +V - 2.0 V
	LOW	max. 0.5 V	max. 0.5 V
Rising edge time t_r	max. 200 ns	max. 1 μ s	max. 1 μ s
Falling edge time t_f	max. 200 ns	max. 1 μ s	max. 1 μ s
Short circuit proof outputs ²⁾	yes ³⁾	yes	yes
Reverse polarity protection of the power supply	no	no	yes
UL approval	file 224618		
CE compliant acc. to	EMC guideline 2014/30/EU RoHS guideline 2011/65/EU		

Terminal assignment

Output circuit	Type of connection	Cable (isolate unused wires individually before initial start-up)								
1, 3, 4	1 ... 8	Signal:	0 V	+V	A	\bar{A}	B	\bar{B}	0	$\bar{0}$
		Core color:	WH	BN	GN	YE	GY	PK	BU	RD

- +V: Encoder power supply +V DC
- 0 V: Encoder power supply ground GND (0 V)
- A, \bar{A} : Incremental output channel A
- B, \bar{B} : Incremental output channel B
- 0, $\bar{0}$: Reference signal

1) For versions with push-pull output and power supply >15 V DC: max. 55°C [+131°F].
2) If power supply correctly applied.
3) Only one channel allowed to be shorted-out:
if +V = 5 V DC short circuit to channel, 0 V, or +V is permitted.
if +V = 5 ... 30 V DC short circuit to channel or 0 V is permitted.
4) Max. recommended cable length 30 m [98.43'].

Incremental encoders

Compact plastic housing, optical

3700 / 3720 (shaft / hollow shaft)

Push-pull / RS422

Dimensions shaft version

Dimensions in mm [inch]

Clamping-synchro flange, \varnothing 36.8 [1.45]

Flange type 1

- 1 3 x M3, 6 [0.24] deep

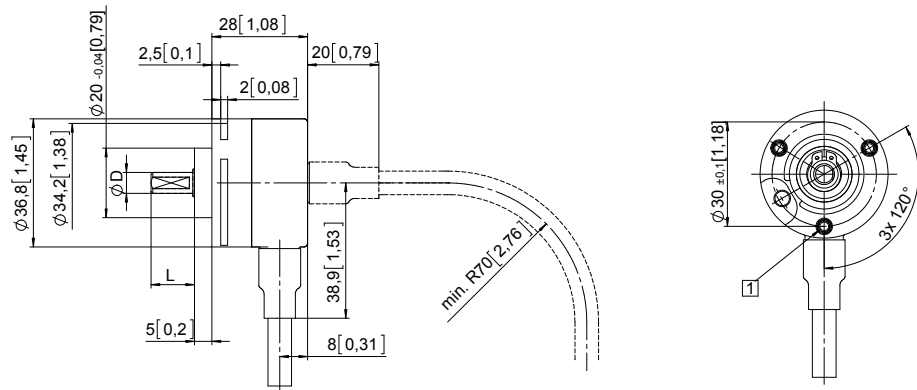

D	Fit	L
4 [0.16]	h7	12.5 [0.49]
5 [0.20]	h7	12.5 [0.49]
6 [0.24]	h7	12.5 [0.49]
8 [0.32]	h7	12.5 [0.49]
1/4"	h7	12.5 [0.49]

Flange adapter, \varnothing 40 [1.57]

Flange type A

- 1 3 x M3, 6 [0.24] deep

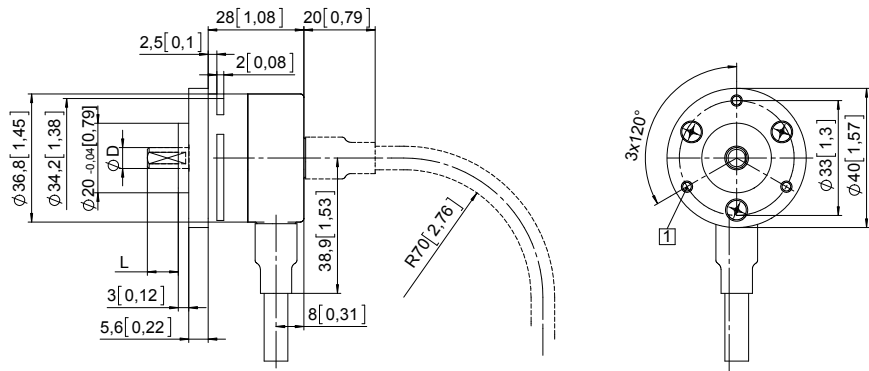

D	Fit	L
4 [0.16]	h7	8.9 [0.35]
5 [0.20]	h7	8.9 [0.35]
6 [0.24]	h7	8.9 [0.35]
8 [0.32]	h7	8.9 [0.35]
1/4"	h7	8.9 [0.35]

Incremental encoders

Compact plastic housing, optical	3700 / 3720 (shaft / hollow shaft)	Push-pull / RS422
---	---	--------------------------

Dimensions hollow shaft version

Dimensions in mm [inch]

Flange with spring element, short
(long spring element version is shown dashed)

Flange type 1 (2)

- 1 Slot spring element, recommendation: cylindrical pin DIN 7, \varnothing 4 [0.16]
- 2 Spring element, long
- 3 Recommended torque for the clamping ring 1.0 Nm

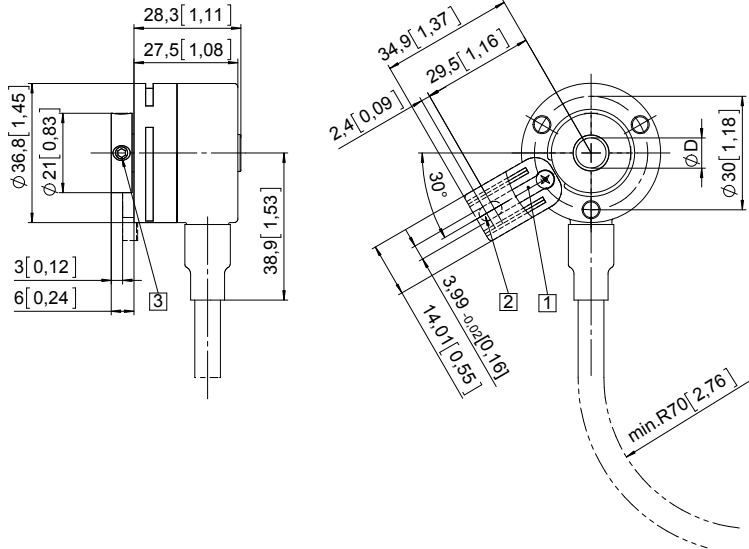

D	Fit
4 [0.16]	H7
5 [0.20]	H7
6 [0.24]	H7
8 [0.32]	H7
1/4"	H7

Flange with stator coupling, \varnothing 46 [1.81]

Flange type 5

- 1 Recommended torque for the clamping ring 1.0 Nm

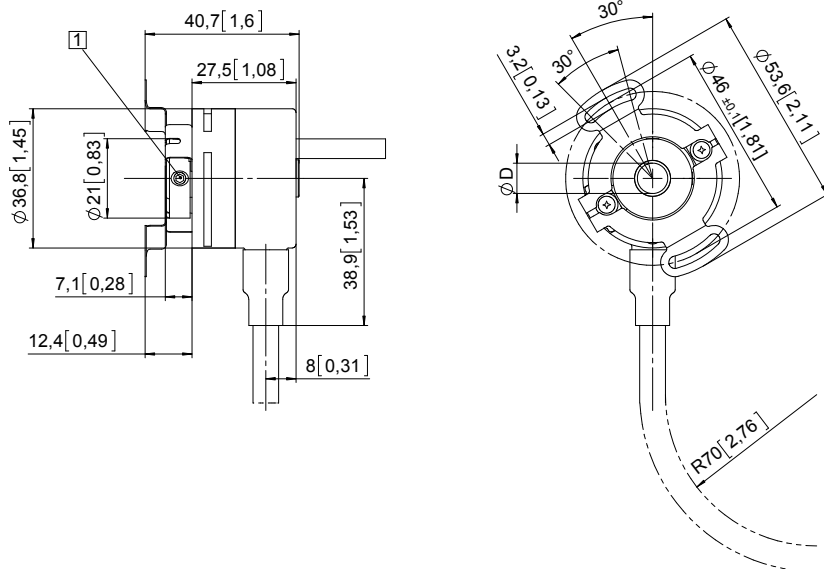

D	Fit
4 [0.16]	H7
5 [0.20]	H7
6 [0.24]	H7
8 [0.32]	H7
1/4"	H7