

# Type 2 surge protection plug - VAL-MS 230 ST - 2798844

Please be informed that the data shown in this PDF Document is generated from our Online Catalog. Please find the complete data in the user's documentation. Our General Terms of Use for Downloads are valid (<http://phoenixcontact.com/download>)



Surge protection connector type 2 with high-capacity varistor for VAL-MS base element, thermal monitoring, visual fault warning. Design: 230 V AC



## Key Commercial Data

Packing unit	10 pc
GTIN	 4 017918 073947
GTIN	4017918073947
Weight per Piece (excluding packing)	41.500 g
Custom tariff number	85363010
Country of origin	Germany

## Technical data

### Dimensions

Height	52.4 mm
Width	17.5 mm
Depth	55.3 mm
Horizontal pitch	1 Div.

### Ambient conditions

Degree of protection	IP20
Ambient temperature (operation)	-40 °C ... 80 °C
Ambient temperature (storage/transport)	-40 °C ... 80 °C
Altitude	≤ 2000 m (amsl (above mean sea level))
Permissible humidity (operation)	5 % ... 95 %
Shock (operation)	25g (Half-sine / 11 ms / 3x ±X, ±Y, ±Z)
Vibration (operation)	5g (10 ... 500 Hz / 2.5 h / X, Y, Z)

### General

IEC test classification	II
-------------------------	----

# Type 2 surge protection plug - VAL-MS 230 ST - 2798844

## Technical data

### General

	T2
EN type	T2
IEC power supply system	TN
	TT
Mode of protection	L-N
	L-PEN
Mounting type	on base element
Color	jet black RAL 9005
Housing material	PA 6.6
Degree of pollution	2
Flammability rating according to UL 94	V-0
Type	DIN rail module, two-section, divisible
Number of positions	1
Arrester can be tested with CHECKMASTER from software version:	From SW rev. 1.10
Surge protection fault message	optical

### Protective circuit

Nominal voltage $U_N$	240/415 V AC (TN)
	240/415 V AC (TT)
Nominal frequency $f_N$	50 Hz (60 Hz)
Maximum continuous voltage $U_C$	275 V AC
Residual current $I_{PE}$	$\leq 0.45$ mA
Standby power consumption $P_C$	$\leq 120$ mVA
Nominal discharge current $I_n$ (8/20) $\mu$ s	20 kA
Maximum discharge current $I_{max}$ (8/20) $\mu$ s	40 kA
Short-circuit current rating $I_{SCCR}$	25 kA
Voltage protection level $U_p$	$\leq 1.35$ kV
Residual voltage $U_{res}$	$\leq 1.35$ kV (at $I_n$ )
	$\leq 1.1$ kV (at 10 kA)
	$\leq 1$ kV (at 5 kA)
	$\leq 0.9$ kV (at 3 kA)
TOV behavior at $U_T$	335 V AC (5 s / withstand mode)
	440 V AC (120 min / safe failure mode)
Response time $t_A$	$\leq 25$ ns
Max. backup fuse with branch wiring	125 A (gG)

### Connection data

Connection method	pluggable
-------------------	-----------

### UL specifications

SPD Type	4CA
Maximum continuous operating voltage MCOV (L-N)	275 V AC

## Type 2 surge protection plug - VAL-MS 230 ST - 2798844

### Technical data

#### UL specifications

Nom. voltage	230 V AC
Mode of protection	L-N
Power distribution system	Single phase
Nominal frequency	50/60 Hz
Measured limiting voltage MLV (L-N)	1910 V
Nominal discharge current $I_n$ (L-N)	20 kA

#### Standards and Regulations

Standards/regulations	IEC 61643-11 2011
	EN 61643-11 2012

#### Environmental Product Compliance

China RoHS	Environmentally Friendly Use Period = 50 years
	For details about hazardous substances go to tab "Downloads", Category "Manufacturer's declaration"

### Drawings

## Type 2 surge protection plug - VAL-MS 230 ST - 2798844

Circuit diagram



## Type 2 surge protection plug - VAL-MS 230 ST - 2798844

Dimensional drawing

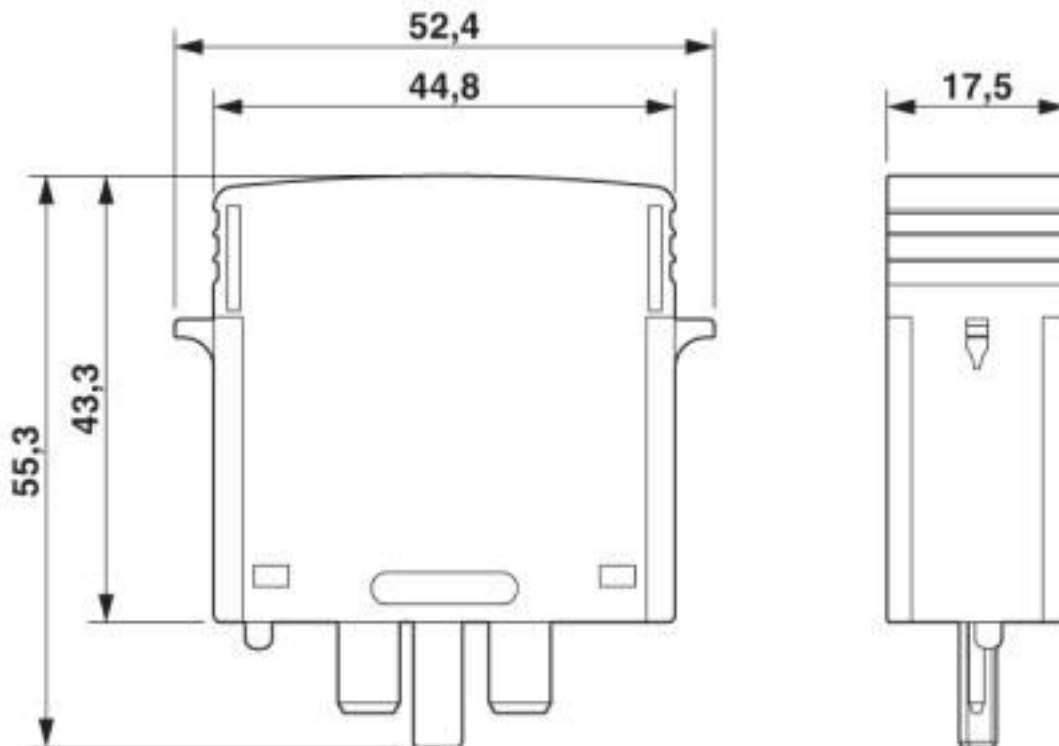

### Classifications

#### eCl@ss

eCl@ss 10.0.1	27130890
eCl@ss 4.0	27130800
eCl@ss 4.1	27130800
eCl@ss 5.0	27130800
eCl@ss 5.1	27130800
eCl@ss 6.0	27130800
eCl@ss 7.0	27130805
eCl@ss 8.0	27130890
eCl@ss 9.0	27130890

#### ETIM

ETIM 2.0	EC000941
ETIM 3.0	EC000941
ETIM 4.0	EC000941
ETIM 5.0	EC002496
ETIM 6.0	EC000941
ETIM 7.0	EC000941

# Type 2 surge protection plug - VAL-MS 230 ST - 2798844

## Classifications

### UNSPSC

UNSPSC 6.01	30212010
UNSPSC 7.0901	39121610
UNSPSC 11	39121610
UNSPSC 12.01	39121610
UNSPSC 13.2	39121620
UNSPSC 18.0	39121620
UNSPSC 19.0	39121620
UNSPSC 20.0	39121620
UNSPSC 21.0	39121620

## Approvals

### Approvals

#### Approvals

CSA / GL / CCA / UL Recognized / KEMA-KEUR / cUL Recognized / IECCE CB Scheme / ÖVE / EAC / EAC / cULus Recognized

#### Ex Approvals

### Approval details

CSA		<a href="http://www.csagroup.org/services-industries/product-listing/">http://www.csagroup.org/services-industries/product-listing/</a>	13631
-----	---	---	-------

GL		<a href="https://approvalfinder.dnvgl.com/">https://approvalfinder.dnvgl.com/</a>	94385-10 HH
----	---	---	-------------

CCA			NTR-AT 1947-A
-----	--	--	---------------

UL Recognized		<a href="http://database.ul.com/cgi-bin/XYV/template/LISEXT/1FRAME/index.htm">http://database.ul.com/cgi-bin/XYV/template/LISEXT/1FRAME/index.htm</a>	FILE E 330181
---------------	---	---	---------------

KEMA-KEUR		<a href="http://www.dekra-certification.com">http://www.dekra-certification.com</a>	71-113273
-----------	---	---	-----------

# Type 2 surge protection plug - VAL-MS 230 ST - 2798844

## Approvals

cUL Recognized		<a href="http://database.ul.com/cgi-bin/XYV/template/LISEXT/1FRAME/index.htm">http://database.ul.com/cgi-bin/XYV/template/LISEXT/1FRAME/index.htm</a>	FILE E 330181
IECEE CB Scheme		<a href="http://www.iecee.org/">http://www.iecee.org/</a>	AT 2905/M1
ÖVE		<a href="https://www.ove.at/zertifizierung-pz/zertifizierungsregister/">https://www.ove.at/zertifizierung-pz/zertifizierungsregister/</a>	18583-001-14
EAC			EAC-Zulassung
EAC			RU C-DE.*09.B.00169
cULus Recognized			

## Accessories

### Accessories

### Device marking

Zack marker strip - ZBN 18:UNBEDRUCKT - 2809128



Zack marker strip, Strip, white, unlabeled, can be labeled with: CMS-P1-PLOTTER, PLOTMARK, mounting type: snap into tall marker groove, for terminal block width: 18 mm, lettering field size: 18 x 5 mm, Number of individual labels: 5

---

### Labeled device marker

## Type 2 surge protection plug - VAL-MS 230 ST - 2798844

### Accessories

Marker for terminal blocks - ZBN 18,LGS:ERDE - 2749589



Marker for terminal blocks, Strip, white, labeled, horizontal: Grounding symbol, mounting type: snap into tall marker groove, for terminal block width: 18 mm, lettering field size: 18 x 5 mm, Number of individual labels: 5

Marker for terminal blocks - ZBN 18,LGS:L1-N,ERDE - 2749576



Marker for terminal blocks, Strip, white, labeled, horizontal: L1, L2, L3, N, GND, mounting type: snap into tall marker groove, for terminal block width: 18 mm, lettering field size: 18 x 5 mm, Number of individual labels: 5

### Marker pen

Marker pen - B-STIFT - 1051993



Marker pen, for manual labeling of unprinted Zack strips, smear-proof and waterproof, line thickness 0.5 mm

### Additional products

Type 2 surge protection base element - VAL-MS BE - 2817741



Base element for type 2 arresters of the VALVETRAB MS series of products. Design: 1-channel

Type 2 surge protection base element - VAL-MS BE/FM - 2817738



Base element for type 2 arresters of the VALVETRAB MS series of products, with remote indication contact. Design: 1-channel