

DC METAL FACE INDUCTIVE PROXIMITY SWITCH

M 8	
●	○
1 mm	2 mm
Stainless steel	
●	

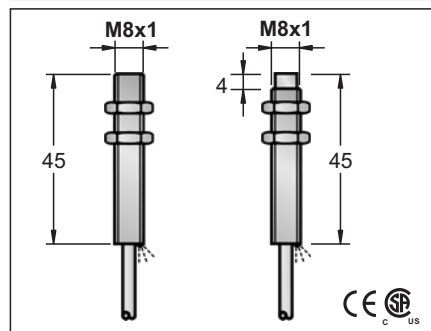

10-30VDC or 10-55VDC	
<10%	
<10mA	
200mA	
<0.01mA	
-	
-	
<1.5V	
500HZ	
0.1ms/0.1ms	
<15%(Sr)	
<1.0%(Sr)	
IP67	
-25 °C - +70 °C	
<10%(Sr)	
YES	
220mA	
<10ms	
RFI>3V/m / EFT>1KV / ESD>4KV (contact)	
IEC 60947-5-2, Part 7.4.1 / IEC 60947-5-2, Part 7.4.2	
Stainless steel	

FCS1-0801N-A3U2	1	FCS2-0802N-A3U2
FCS1-0801N-B3U2	2	FCS2-0802N-B3U2
FCS1-0801P-A3U2	3	FCS2-0802P-A3U2
FCS1-0801P-B3U2	4	FCS2-0802P-B3U2
FCS1-0801P-S4U2	6	FCS2-0802P-S4U2
FCS1-0801N-S4U2	5	FCS2-0802N-S4U2
FCS1-0801C-A2U2	7	FCS2-0802C-A2U2
FCS1-0801C-B2U2	8	FCS2-0802C-B2U2
HGS1-0801N-A3U2	1	HGS2-0802N-A3U2
HGS1-0801N-B3U2	2	HGS2-0802N-B3U2
HGS1-0801P-A3U2	3	HGS2-0802P-A3U2
HGS1-0801P-B3U2	4	HGS2-0802P-B3U2

3 φ 3x0.15	
Approx.33 g	Approx.32 g

M 8	
●	○
1 mm	2 mm
Stainless steel	
●	

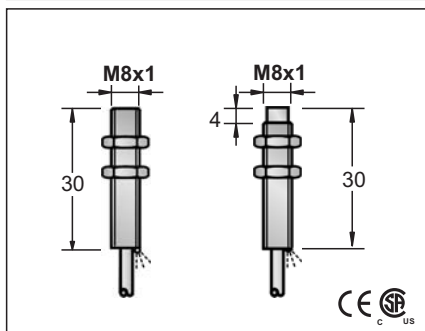

10-30VDC or 10-55VDC	
<10%	
<10mA	
200mA	
<0.01mA	
-	
-	
<1.5V	
500HZ	
0.1ms/0.1ms	
<15%(Sr)	
<1.0%(Sr)	
IP67	
-25 °C - +70 °C	
<10%(Sr)	
YES	
220mA	
<10ms	
RFI>3V/m / EFT>1KV / ESD>4KV (contact)	
IEC 60947-5-2, Part 7.4.1 / IEC 60947-5-2, Part 7.4.2	
Stainless steel	

FCS1-0801N-A3S2	1	FCS2-0802N-A3S2
FCS1-0801N-B3S2	2	FCS2-0802N-B3S2
FCS1-0801P-A3S2	3	FCS2-0802P-A3S2
FCS1-0801P-B3S2	4	FCS2-0802P-B3S2
FCS1-0801P-S4S2	6	FCS2-0802P-S4S2
FCS1-0801N-S4S2	5	FCS2-0802N-S4S2
FCS1-0801C-A2S2	7	FCS2-0802C-A2S2
FCS1-0801C-B2S2	8	FCS2-0802C-B2S2
HGS1-0801N-A3S2	1	HGS2-0802N-A3S2
HGS1-0801N-B3S2	2	HGS2-0802N-B3S2
HGS1-0801P-A3S2	3	HGS2-0802P-A3S2
HGS1-0801P-B3S2	4	HGS2-0802P-B3S2

3 φ 3x0.15	
Approx.33 g	Approx.32 g

Please see Page 18 for details and specifications of DC 2-Wire models on this page.

M 8	
●	○
1 mm	2 mm
Stainless steel	
●	

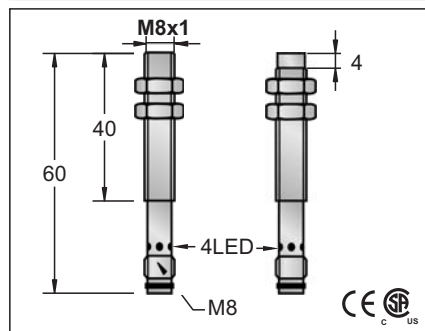

10-30VDC or 10-55VDC	
<10%	
<10mA	
200mA	
<0.01mA	
-	
-	
<1.5V	
500HZ	
0.1ms/0.1ms	
<15%(Sr)	
<1.0%(Sr)	
IP67	
-25 °C - +70 °C	
<10%(Sr)	
YES	
220mA	
<10ms	
RFI>3V/m / EFT>1KV / ESD>4KV (contact)	
IEC 60947-5-2, Part 7.4.1 / IEC 60947-5-2, Part 7.4.2	
Stainless steel	

FCS1-0801N-ACU3	29	FCS2-0802N-ACU3
FCS1-0801N-BCU3	29	FCS2-0802N-BCU3
FCS1-0801P-ACU3	30	FCS2-0802P-ACU3
FCS1-0801P-BCU3	30	FCS2-0802P-BCU3
FCS1-0801P-SCU4	32	FCS2-0802P-SCU4
FCS1-0801N-SCU4	31	FCS2-0802N-SCU4
FCS1-0801C-ACU3	39	FCS2-0802C-ACU3
FCS1-0801C-BCU3	77	FCS2-0802C-BCU3
HGS1-0801N-AGU3	29	HGS2-0802N-AGU3
HGS1-0801N-BCU3	29	HGS2-0802N-BCU3
HGS1-0801P-AGU3	30	HGS2-0802P-AGU3
HGS1-0801P-BCU3	30	HGS2-0802P-BCU3

3 φ 3x0.15	
Approx.18 g	Approx.17 g

Note:

Coming Soon : Part numbers with underline
 In Preparation: Part numbers with a line through the middle