

HF10F

MINIATURE HIGH POWER RELAY



Safety approval is pending.



Features

- 10A switching capability
- Bridge transformation available, Multiple switching capability (2C, 3C type)
- Standard electron tube terminal, QC terminal
- With test button
- Blowout magnet type
- Sockets available

RoHS compliant

CONTACT DATA

Contact arrangement	QZ, 2Z, 3Z
Contact resistance	≤ 100mΩ (1A 24VDC)
Contact material	AgSnO ₂ , AgCdO
Contact rating (Res. load)	HF10F (Without blowout magnet type) : QZ/2Z: 10A 250VAC / 30VDC 3Z: (NO) 10A 250VAC / 30VDC (NC) 5A 250VAC / 30VDC HF10F-QV (Blowout magnet type) : QZ:(NO) 5A 220VDC QZ: (NC) 2A 220VDC 2Z: (NO) 5A 150VDC 2Z:(NC) 2A 150VDC
Max. switching voltage	250VAC / 220VDC
Max. switching current	10A
Max. switching power	2500VA / 300W
Mechanical endurance	HF10F (Without blowout magnet type) : 1 x 10 ⁷ OPS HF10F-QV (Blowout magnet type) : 5 x 10 ⁶ OPS
Electrical endurance	HF10F (Without blowout magnet type) : QZ/2Z type: 1 x 10 ⁵ OPS (10A 250VAC/30VDC; Resistive load, Room temp., 1s on 9s off) 3Z type: 1 x 10 ⁵ OPS (NO: 10A 250VAC/30VDC; NC: 5A 250VAC/30VDC; Resistive load, Room temp., 1s on 9s off) HF10F-QV (Blowout magnet type) : QZ type: 1 x 10 ⁴ OPS (NO: 5A 220VDC; NC: 2A 220VDC; Resistive load, Room temp., 1s on 9s off) 2Z type: 1 x 10 ⁴ OPS (NO: 5A 150VDC; NC: 2A 150VDC; Resistive load, Room temp., 1s on 9s off, Moving spring connect load positive)

Notes: The data shown above are initial values.

COIL

Coil power	DC type: Approx. 1.4W; AC type: Approx. 3.0VA
------------	--

CHARACTERISTICS

Insulation resistance		1000MΩ (500VDC)
Dielectric strength	Between coil & contacts	2500VAC 1min
	Between open contacts	1500VAC 1min
	Between contact sets	2000VAC 1min
Operate time (at nomi. volt.)		≤ 30ms(DC)
Release time (at nomi. volt.)		≤ 30ms(DC)
Temperature rise (at nomi. volt.)		100K max
Shock resistance	Functional	98m/s ²
	Destructive	980m/s ²
Vibration resistance		10Hz ~ 55Hz 1.5mm DA
Humidity		5% to 85% RH
Ambient temperature		-40°C to 55°C
Termination		Standard electron tube terminal QC terminal
Unit weight		Approx. 90g
Construction		Dust protected

COIL DATA

23°C

Nominal Voltage VDC	Pick-up Voltage VDC max.	Drop-out Voltage VAC min.	Max. (2) Voltage VAC	Coil Resistance Ω
6	≤ 4.80	≥ 0.60	7.20	23.5 x (1±10%)
12	≤ 9.60	≥ 1.20	14.4	120 x (1±10%)
24	≤ 19.2	≥ 2.40	28.8	470 x (1±10%)
48	≤ 38.4	≥ 4.80	57.6	1800 x (1±10%)
60	≤ 48.0	≥ 6.00	72.0	2790 x (1±10%)
100	≤ 80.0	≥ 10.0	120	7500 x (1±10%)
110	≤ 88.0	≥ 11.0	132	
120	≤ 96.0	≥ 12.0	144	
220	≤ 176	≥ 22.0	264	37000 x (1±10%)



HONGFA RELAY

ISO9001, IATF16949, ISO14001, OHSAS18001, IECQ QC 080000 CERTIFIED

2023 Rev. 1.00

COIL DATA

23°C

Nominal Voltage VAC	Pick-up Voltage VAC max.	Drop-out Voltage VAC min.	Max. ⁽²⁾ Voltage VAC	Coil Resistance Ω
6	≤4.80	≥1.80	7.20	3.9 x (1±10%)
12	≤9.60	≥3.60	14.4	16.9 x (1±10%)
24	≤19.2	≥7.20	28.8	72 x (1±10%)
48	≤38.4	≥14.4	57.6	290x (1±10%)
110	≤88.0	≥33.0	132	1700 x (1±10%)
120	≤96.0	≥36.0	144	
110/120	≤88.0	≥36.0	132	
220	≤176	≥66.0	264	6500 x (1±10%)
230	≤184	≥69.0	276	
220/240	≤176	≥72.0	264	
240	≤192	≥72.0	288	

Notes: 1) All values unspecified are at room temperature.

2) Maximum voltage refers to the maximum voltage which relay coil could endure in a short period of time.

SAFETY APPROVAL IS PENDING

UL/CUL	HF10F (Without blowout magnet type)	10A 250VAC/30VDC 1/3HP 120VAC 1/3HP 240VAC 1/2HP 277VAC
	HF10F-QV (Blowout magnet type)	10A 250VAC/30VDC QZ:(NO) 5A 220VDC QZ: (NC) 2A 220VDC 2Z: (NO) 5A 150VDC 2Z:(NC) 2A 150VDC

ORDERING INFORMATION

Type	HF10F	F	-Q	V	/230	A	-2Z	D	T	G (XXX)
Button Function	F: Standard type without button H: With test button type									
Terminal arrangement	Q: QC terminal(without button) Nil: Standard electrontube terminal									
Arc blowout	V: Blowout magnet (NO 3Z type, only square arrangement) Nil: Without arc blowout fuction									
Coil voltage	DC: 6, 12, 24, 48, 60, 100, 110, 120, 220 AC: 6, 12, 24, 48, 110, 120, 110/120,120,220, 220/230,240									
Coil voltage form	A: AC D: DC									
Contact arrangement	QZ: Bridge transformation 2Z: 2 Form C 3Z: 3 Form C(Without blowout magnet type)									
Combined component code	D: With LED type DJ: With LED and diode type(only for DC type) Nil: Standard									
Contact material	T: AgSnO ₂ Nil: AgCdO									
Contact plating	G: Gold plated Nil: No gold plated									
Special code ¹⁾	XXX: Customer special requirement Nil: Standard									

Notes: 1) The customer special requirement express as special code after evaluating by Hongfa.

Outline Dimensions
(Bottom view)

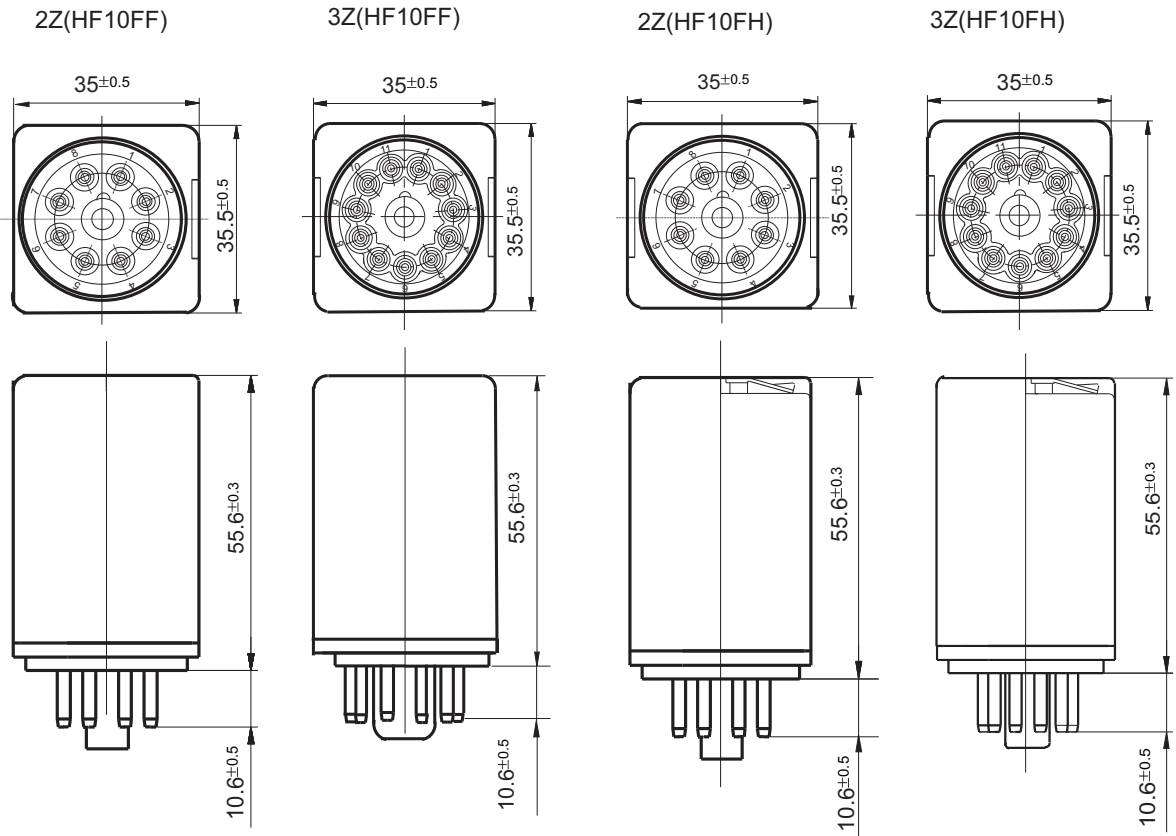

QZ/2Z(HF10FF-Q/HF10FF-QV)

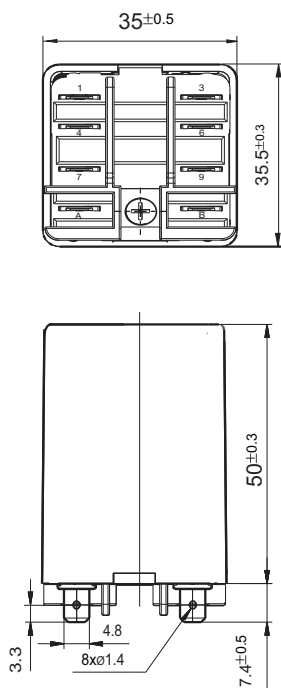

3Z(HF10FF-Q)

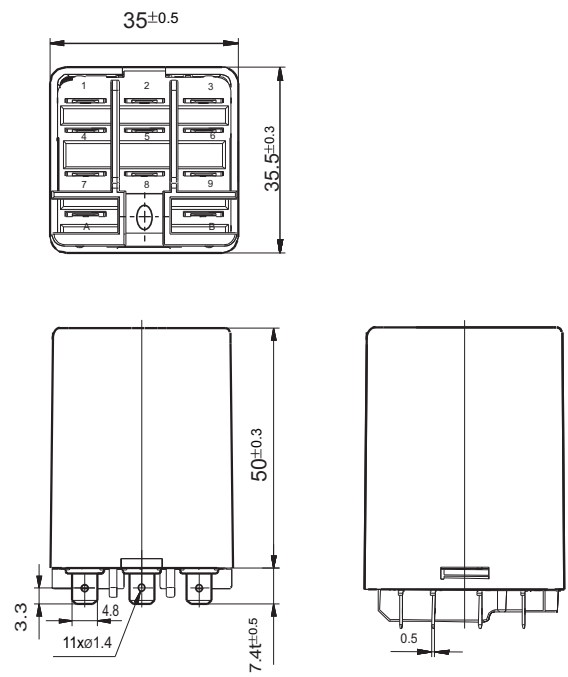

Wiring Diagram

(Bottom view)

2Z
(HF10FF/HF10FH)

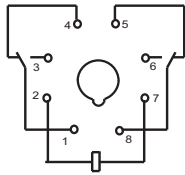

2Z
(HF10FF/HF10FH With LED)

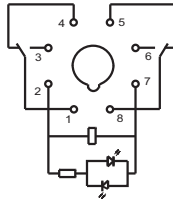

2Z
(HF10FF/HF10FH With LED, With fly-wheel diode)

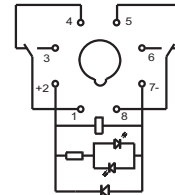

3Z
(HF10FF/HF10FH)

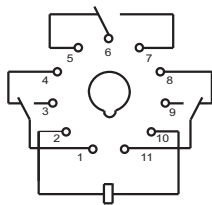

3Z
(HF10FF/HF10FH With LED)

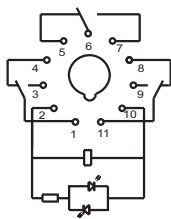

3Z
(HF10FF/HF10FH With LED, With fly-wheel diode)

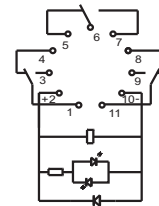

QZ(HF10FF-Q/HF10FF-QV)

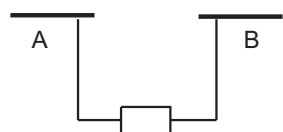
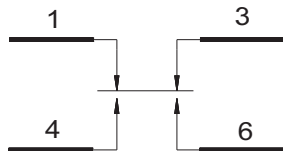

QZ(HF10FF-Q/HF10FF-QV With LED)

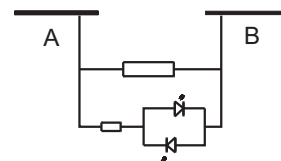
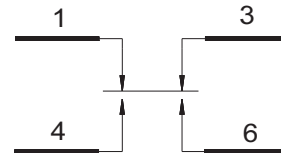

OUTLINE DIMENSIONS, WIRING DIAGRAM AND PC BOARD LAYOUT

Unit: mm

QZ
(HF10FF-Q/HF10FF-QV With LED, With fly-wheel diode)

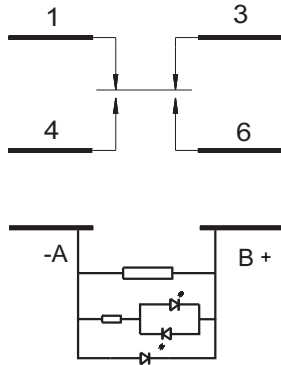

2Z(HF10FF-Q)

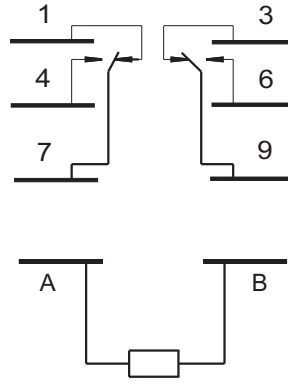

2Z(HF10FF-QV)

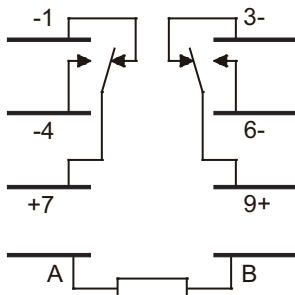

2Z(HF10FF-Q With LED)

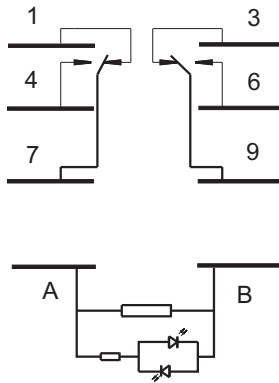

2Z(HF10FF-QV With LED)

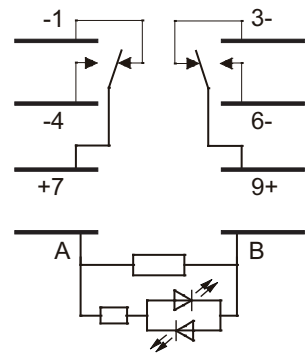

2Z
(HF10FF-Q With LED, With fly-wheel diode)

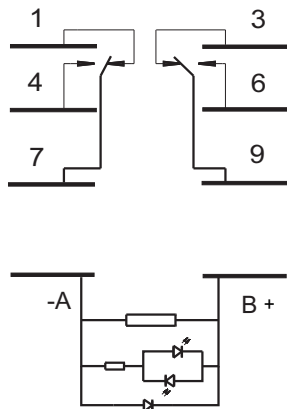

2Z
(HF10FF-QV With LED, With fly-wheel diode)

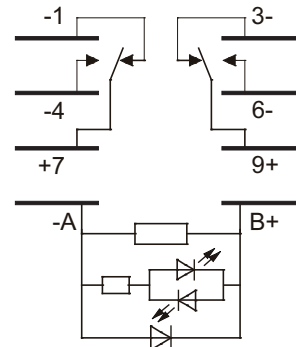

OUTLINE DIMENSIONS, WIRING DIAGRAM AND PC BOARD LAYOUT

Unit: mm

3Z(HF10FF-Q)

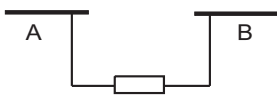
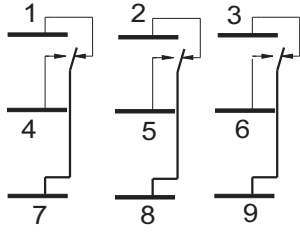

3Z(HF10FF-Q With LED)

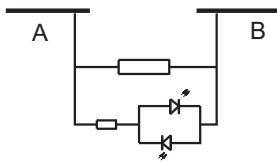
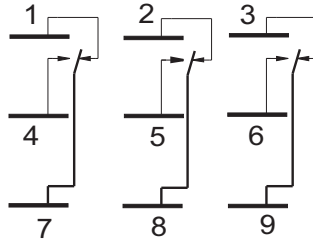

3Z
(HF10FF-Q With LED, With fly-wheel diode)

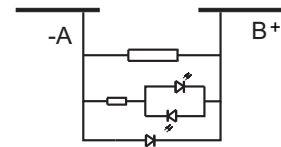
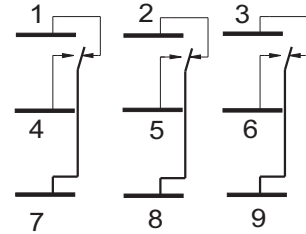

PCB Layout (Bottom view)

HF10FF-2Z

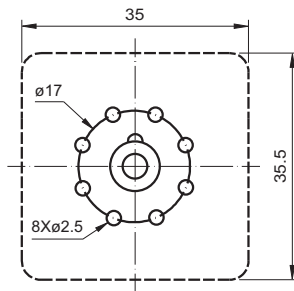

HF10FF-3Z

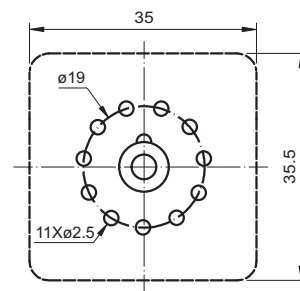

HF10FF-Q-2Z/HF10FF-Q-QZ

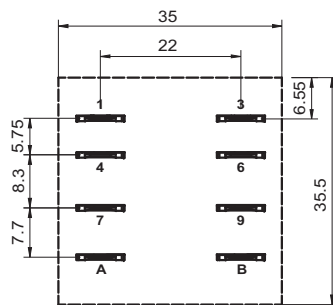

HF10FF-Q-3Z

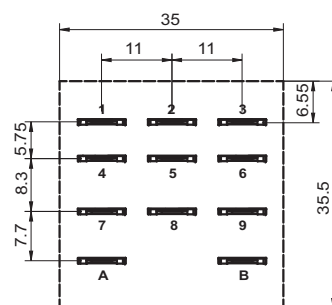

Relay Sockets



Features



- The dielectric strength can reach 2000VAC and the insulation resistance is 1000MΩ
- Two mounting types are available: screw mounting and DIN rail mounting.
- With finger protection device are available
- Many kinds of plug-in modules are available with the function of energizing indication and wiring protection.
- Components available: metallic retainer, plug-in modules
- Environmental friendly product (RoHS compliant)

CHARACTERISTICS

Type	Nominal Voltage	Nominal Current	Ambient Temperature	Dielectric Strength min.	Screw Torque	Wire Strip Length	Unit weight
10FF-2Z-C3	250VAC	10A	-40 °C to 70°C	2000VAC	0.6N · m	7mm	Approx. 49g
10FF-2Z-C4	250VAC	10A	-40 °C to 70°C	2000VAC	0.6N · m	7mm	Approx. 61g
10FF-3Z-C3	250VAC	10A	-40 °C to 70°C	2000VAC	0.6N · m	7mm	Approx. 56g
10FF-3Z-C4	250VAC	10A	-40 °C to 70°C	2000VAC	0.6N · m	7mm	Approx. 65g

OUTLINE DIMENSIONS, WIRING DIAGRAM AND PC BOARD LAYOUT

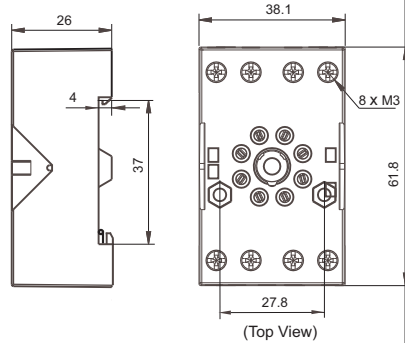
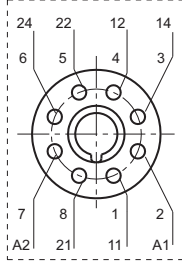
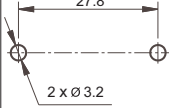

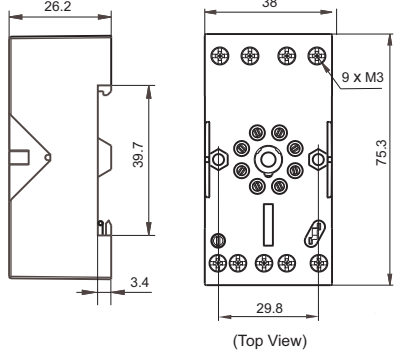
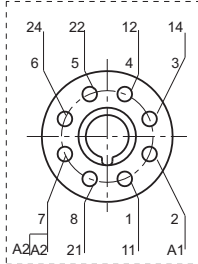
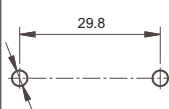
Unit: mm

Socket	Outline Dimensions	Wiring Diagram	PCB Layout	Components Available
<p>10FF-2Z-C3</p>  <p>Screw terminal DIN rail or Screw mounting With finger protection device Applicable for 2 poles</p>	 <p>(Top View)</p>	 <p>(Top View)</p>		<p>metallic retainer 10FF-H1</p>
<p>10FF-2Z-C4</p>  <p>Screw terminal DIN rail or Screw mounting With finger protection device Applicable for 2 poles</p>	 <p>(Top View)</p>	 <p>(Top View)</p>		<p>metallic retainer 10FF-H1 plug-in module HFFAA to HFFHU*</p>

Notes: * Please refer to the product datasheet if plug-in module is required.

OUTLINE DIMENSIONS, WIRING DIAGRAM AND PC BOARD LAYOUT

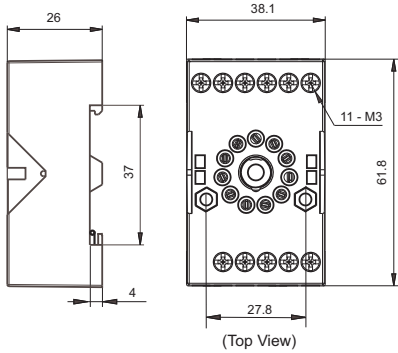
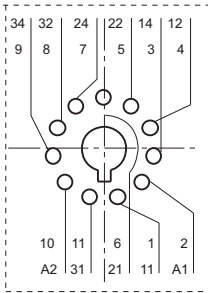
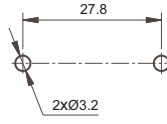
Unit: mm

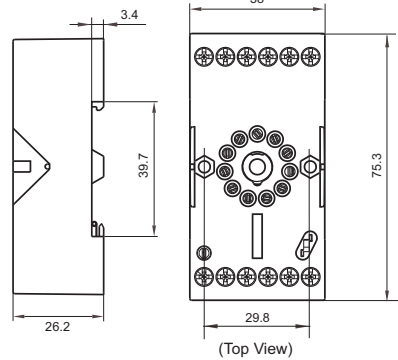
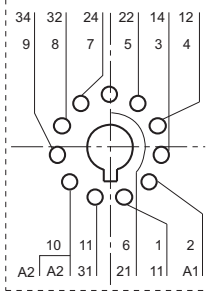
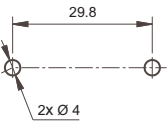
Socket	Outline Dimensions	Wiring Diagram	PCB Layout	Components Available
<p>10FF-3Z-C3</p>  <p>Screw terminal DIN rail or Screw mounting With finger protection device Applicable for 3 poles</p>	 <p>(Top View)</p>	 <p>(Top View)</p>		<p>metallic retainer 10FF-H1</p>
<p>10FF-3Z-C4</p>  <p>Screw terminal DIN rail or Screw mounting With finger protection device Applicable for 3 poles</p>	 <p>(Top View)</p>	 <p>(Top View)</p>		<p>metallic retainer 10FF-H1 plug-in module HFFAA to HFFHU*</p>

DIMENSION OF RELATED COMPONENT (AVAILABLE)

Unit: mm

Retainer

10FF-H1 (Metallic retainer)

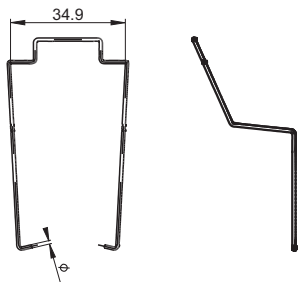

Things to be noticed when selecting sockets:

1. Please choose suitable relay socket according to the actual mounting environment, relay contact poles and terminal layout. If there is any query on selection, please contact Hongfa for the technical service.
2. As for related components, they should be selected separately. Please do give clear indication of the types of relay sockets and related components you choose while placing order.
3. The above is only an example of typical socket and related component type which is suitable to HF10FF relay. If you have any special requirements, please contact us.
4. Main outline dimension, outline dimension $>50\text{mm}$, tolerance should be $\pm 1\text{mm}$; $20\text{mm} < \text{outline dimension} \leq 50\text{mm}$, tolerance should be $\pm 0.5\text{mm}$; $5\text{mm} < \text{outline dimension} \leq 20\text{mm}$, tolerance should be $\pm 0.4\text{mm}$; outline dimension $\leq 5\text{mm}$, tolerance should be $\pm 0.3\text{mm}$.
5. DIN rail mounting: recommend to use standard rail $35 \times 7.5 \times 1\text{mm}$, $35 \times 15 \times 1\text{mm}$.

Disclaimer

The specification is for reference only. See to "Terminology and Guidelines" for more information. Specifications subject to change without notice. We could not evaluate all the performance and all the parameters for every possible application. Thus the user should be in a right position to choose the suitable product for their own application. If there is any query, please contact Hongfa for the technical service. However, it is the user's responsibility to determine which product should be used only.

© Xiamen Hongfa Electroacoustic Co., Ltd. All rights of Hongfa are reserved.