

■ Description

FUJI offers a new motor control system – DUO series for the international market, designed to IEC standards. The DUO series adds a new family of compact, high-performance combination starters to its IEC-compliant manual motor starters BM3 series, magnetic contactors SC series and thermal overload relays TK series to form a complete line-up of motor control products.

- Short-circuit protective coordination between protective devices and the equipment to be protected
- Conformance to IEC, UL, CSA and other international standards
- Safety and ecological consideration – safety features such as terminals with finger protection, use of recyclable materials, and resources-saving

Manual motor starters (MMS) BM3 series

New circuit breakers for motor use that provide optimal protection by integrating the functions of a molded case circuit breaker and thermal overload relay into a highly compact unit. See page 02/2

Contactors and thermal overload relays SC-M and SC-E series

SC-M series compact magnetic contactors for small capacity motor control for 400V AC, 2.2 to 4kW.

SC-E series magnetic contactors and thermal overload relays featuring terminals with finger protection for 400V AC, 4 to 75kW. See page 02/32

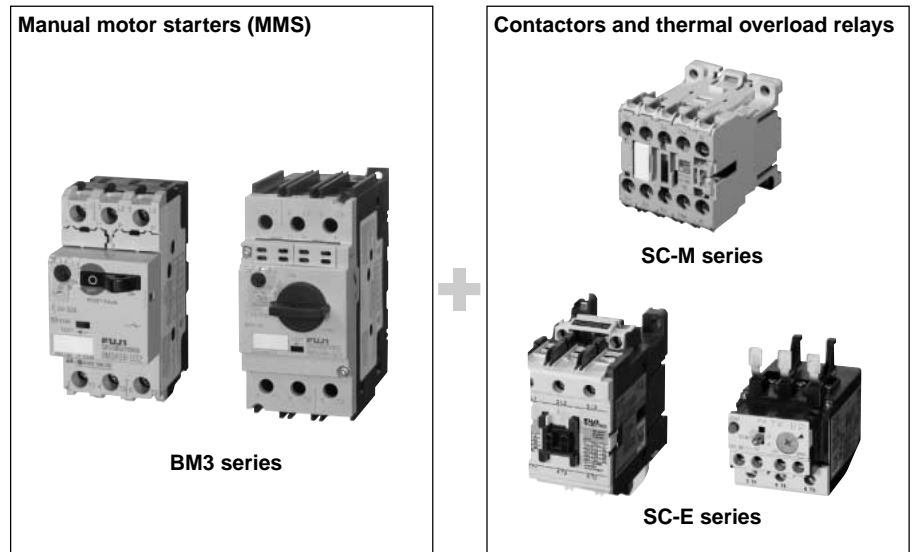

Combination starters

The ability to configure combination starters for compact, reliable motor protection by combining a manual motor starter and a magnetic contactor. See page 02/74

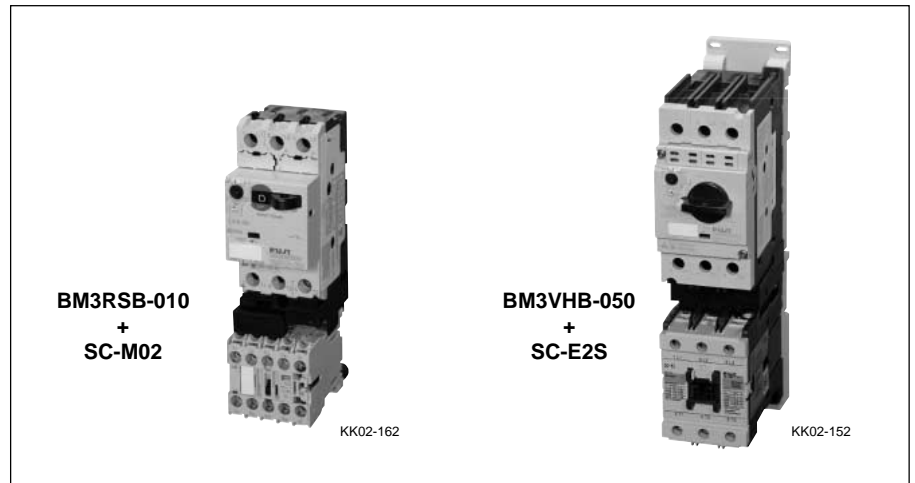

DUO series Manual Motor Starters

General information

Manual motor starters BM3 series

■ Description

Conforming to international standards and combining compactness with high breaking performance, this versatile series features leading-edge motor protection. Molded case circuit breaker and thermal overload relay functions are integrated into a highly compact unit.

■ Features

- Eight types available in two different frame sizes-32AF for the 45mm width and 63AF for the 55mm width
- A wide motor capacity range up to 30kW (400/415V AC, 63A)
- High breaking capacity
Standard breaking capacity: 25, 50, 100kA 400V AC
High breaking capacity: 50, 100kA 400V AC
- Adjustable thermal-magnetic trip types
32AF: BM3RSB and BM3RHB
63AF: BM3VSB and BM3VHB
- Instantaneous trip types
32AF: BM3RSBK and BM3RHBK
63AF: BM3VSBK and BM3VHBK
- Common accessories to reduce inventory
- Short-circuit protective coordination
IEC 60947-4-1 Type1, 2
- Standards
IEC 60947-1, 60947-2, 60947-4-1, UL 508, CSA C22.2 No.14
- Ecological design
Recyclable thermoplastic resin used in plastic parts
Indication of materials used
Cadmium-free contacts
- Both rocker and rotary handle
- ON/OFF and trip state indication for all frames



Circuit breaker functions

- Short-circuit protection
- Overcurrent protection
- Line protection

Thermal overload relay functions

- Overload protection
- Phase-loss protection
- Rated current adjustment
- Ambient temperature compensation



Compactness:
57% reduction

Wiring work:
50% reduction

Manual motor starters BM3 series



KK01-317

BM3RSB and BM3RSBK

Rated current: 0.16 to 32A
Rated insulation voltage: 690V
Operation handle: Rocker handle
Breaking capacity Icu at 400/415V:
• 100kA up to 10A
• 50kA up to 13A
• 25kA up to 32A



AF01-47

BM3VSB and BM3VSBK

Rated current: 10 to 63A
Rated insulation voltage: 1000V
Operation handle: Rotary handle
Breaking capacity Icu at 400/415V:
• 100kA up to 10A
• 50kA up to 13A
• 25kA up to 63A



AF01-42

BM3RHB and BM3RHBK

Rated current: 0.16 to 32A
Rated insulation voltage: 690V
Operation handle: Rotary handle
Breaking capacity Icu at 400/415V:
• 100kA up to 13A
• 50kA up to 32A



AF01-43

BM3VHB and BM3VHBK

Rated current: 10 to 63A
Rated insulation voltage: 1000V
Operation handle: Rotary handle
Breaking capacity Icu at 400/415V:
• 100kA up to 13A
• 50kA up to 63A

■ Manual motor starters for branch circuit protection

The MMS provides reliable protection for overloading and short-circuiting in motor branch circuits.

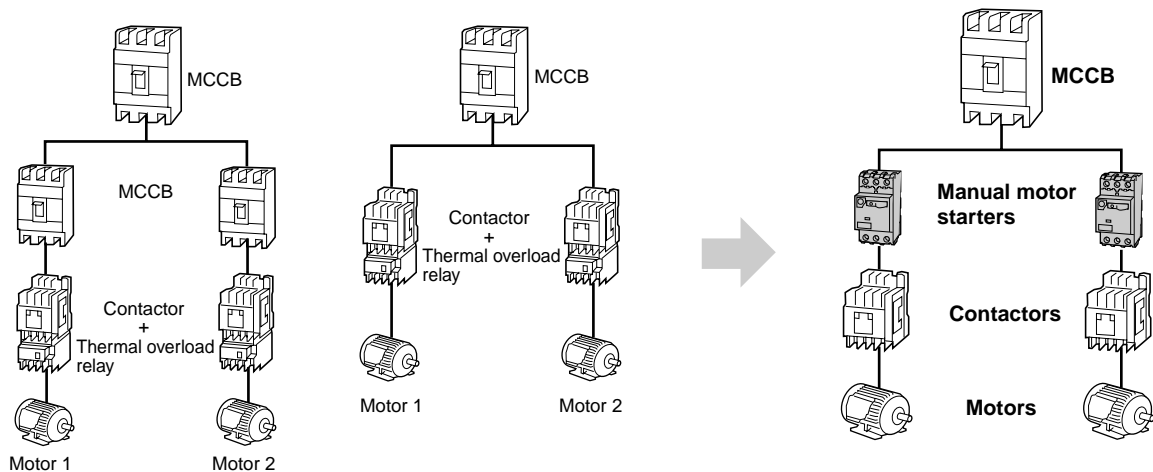

Typical problem in the conventional system



Solution by using MMS system

Short-circuit breaking protection

When numerous small and medium motor loads exist in a circuit requiring high breaking capacity, there is no high-breaking capacity circuit breaker with a small rated current for short-circuit protection.

The MMS can be used in 100kA short-circuit current circuits for three-phase, 240V motors with rated capacity up to 15kW, and in 50kA short-circuit current circuits for three-phase, 415V motors with rated capacity up to 30kW.

Back-up breaking system

When a back-up MCCB is installed upstream to solve the problem described in "short-circuit breaking protection" above, an occurrence of short-circuit failure in a single load circuit also trips the upstream breaker and stops the other operating load circuits.

Despite their compact size, the 32AF and 63AF MMS provide high-performance short-circuit current breaking. They eliminate the need for an upstream circuit breaker for back-up use.

Overload protection

Motor protection breakers cannot be adjusted to match the rated current of the motor being protected.

Equipped with a wide-range current adjustment dial (with maximum/minimum ratio of 1.4 to 1.6), the MMS easily adjusts to match the rated current of the motor, for optimum protection.

Control panel size

Considerable space is required to install a back-up circuit breaker or a combination starter consisting of a circuit breaker and a thermal overload relay. As a result, the panel size has to be increased.

The compact size of the MMS, including thermal overload relay functions, enables a smaller installation area with less wiring space, for a reduction in panel size.

DUO series Manual Motor Starters

General information



■ Accessories

A wide variety of accessories enables a flexible response to changes in specifications.

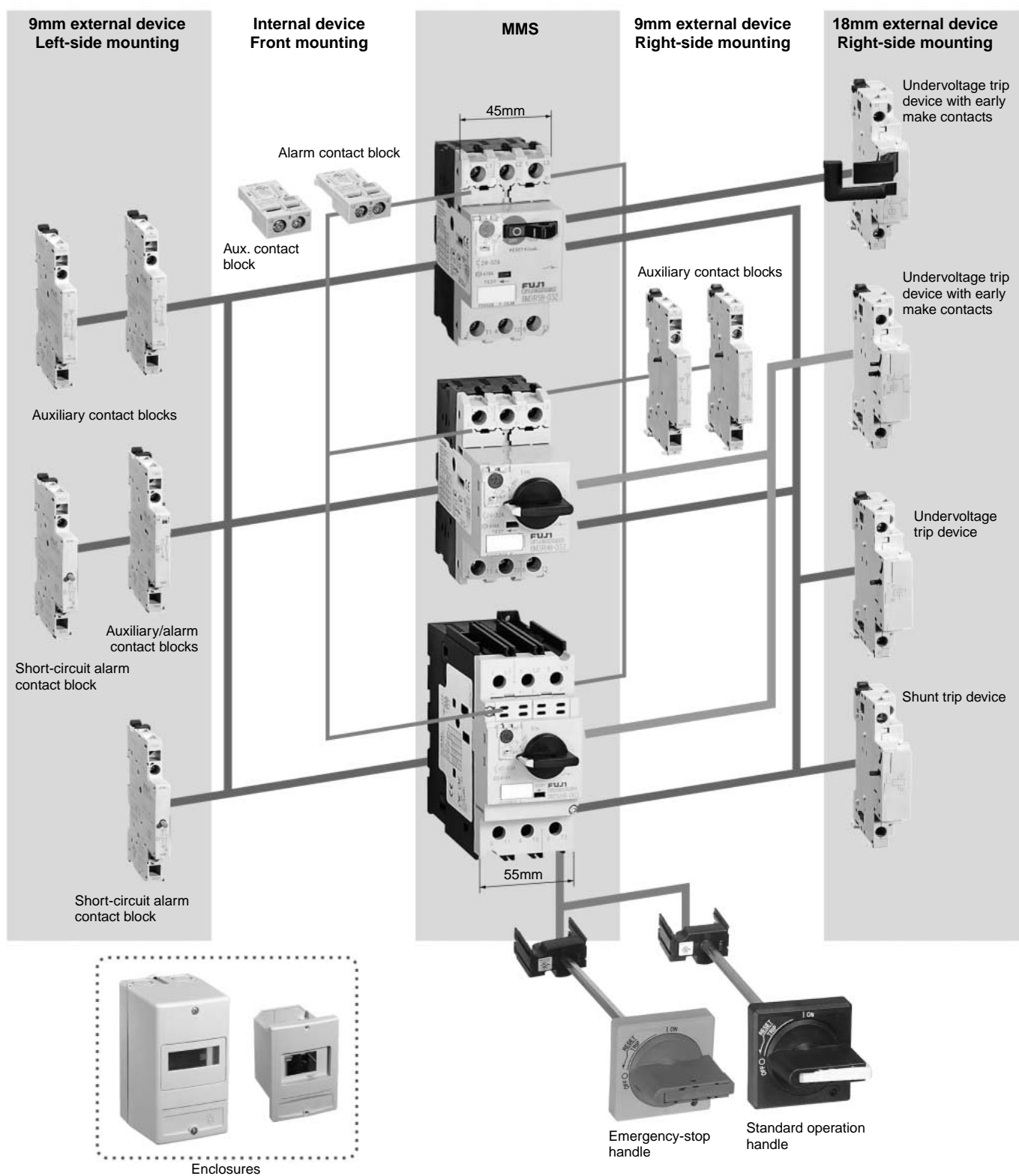
Snap-on fittings speed up mounting.



■ 32AF types and ratings

Adjustable thermal-magnetic trip type Instantaneous trip type		Standard breaking capacity BM3RSB-□  KK01-317						High breaking capacity BM3RHB-□ BM3RHBK-□  AF01-42								
Number of poles		3						3								
Handle type		Rocker						Rotary								
Rated current I _n (A)		0.16 to 32														
Rated operational voltage U _e (V)		200 to 690														
Rated frequency (Hz)		50/60														
Rated insulation voltage U _i (V)		690														
Rated impulse withstand voltage U _{imp} (kV)		6														
Utilization IEC 60947-2 Circuit breaker category		Cat. A														
IEC 60947-4-1 Motor starter		AC-3														
Trip class IEC 60947-4-1 *1		10														
Instantaneous trip characteristic		13 × I _n max.														
Power loss (total of 3-pole)		7W: I _n =0.16 to 25A 8.5W: I _n =32A														
Mechanical durability (operations)		100,000: I _n =0.16 to 25A 70,000: I _n =32A														
Electrical durability (operations)		100,000: I _n =0.16 to 25A 70,000: I _n =32A														
Max. operations per hour (motor start-up)		25														
Phase-loss protection		Provided														
Tripping state indication		Provided														
Test trip function		Provided														
Rated breaking capacity (kA)	Adjustable current range	240V	415V	460V	500V	690V	240V	415V	460V	500V	690V					
	Code I _e : Min.–Max. (A)	230V	400V	440V		600V	230V	400V	440V		600V					
IEC 60947-2 <i>Replace the □ mark in the type number by current range codes.</i>		I _{cu}	I _{cs}	I _{cu}	I _{cs}	I _{cu}	I _{cs}	I _{cu}	I _{cs}	I _{cu}	I _{cs}	I _{cu}	I _{cs}	I _{cu}	I _{cs}	
	P16	0.1–0.16	100 100	100 100	100 100	100 100	100 100	100 100	100 100	100 100	100 100	100 100	100 100	100 100	100 100	100 100
	P25	0.16–0.25	100 100	100 100	100 100	100 100	100 100	100 100	100 100	100 100	100 100	100 100	100 100	100 100	100 100	100 100
	P40	0.25–0.4	100 100	100 100	100 100	100 100	100 100	100 100	100 100	100 100	100 100	100 100	100 100	100 100	100 100	100 100
	P63	0.4–0.63	100 100	100 100	100 100	100 100	100 100	100 100	100 100	100 100	100 100	100 100	100 100	100 100	100 100	100 100
	001	0.63–1	100 100	100 100	100 100	100 100	100 100	100 100	100 100	100 100	100 100	100 100	100 100	100 100	100 100	100 100
	1P6	1–1.6	100 100	100 100	100 100	100 100	100 100	100 100	100 100	100 100	100 100	100 100	100 100	100 100	100 100	100 100
	2P5	1.6–2.5	100 100	100 100	100 100	100 100	100 100	3 2	100 100	100 100	100 100	100 100	100 100	100 100	8 6	8 6
	004	2.5–4	100 100	100 100	100 100	100 100	100 100	3 2	100 100	100 100	100 100	100 100	100 100	100 100	8 6	8 6
	6P3	4–6.3	100 100	100 100	50 38	50 38	3 2	100 100	100 100	100 100	100 100	100 100	50 38	50 38	6 5	6 5
	010	6.3–10	100 100	100 100	15 11	10 8	3 2	100 100	100 100	50 38	50 38	6 5	6 5	6 5	6 5	6 5
	013	9–13	100 100	50 38	10 8	6 5	3 2	100 100	100 100	50 38	42 32	6 5	6 5	6 5	6 5	6 5
	016	11–16	100 100	25 19	10 8	6 5	3 2	100 100	50 38	35*2 27	10 8	4 3	4 3	4 3	4 3	4 3
	020	14–20	50 38	25 19	10 8	6 5	3 2	100 100	50 38	35*2 27	10 8	4 3	4 3	4 3	4 3	4 3
	025	19–25	50 38	25 19	10 8	6 5	3 2	100 100	50 38	35*2 27	10 8	4 3	4 3	4 3	4 3	4 3
	032	24–32	50 38	25 19	10 8	6 5	3 2	100 100	50 38	35*2 27	10 8	4 3	4 3	4 3	4 3	4 3
040	28–40	–	–	–	–	–	–	–	–	–	–	–	–	–	–	
050	35–50	–	–	–	–	–	–	–	–	–	–	–	–	–	–	
063	45–63	–	–	–	–	–	–	–	–	–	–	–	–	–	–	
Dimensions (mm) W×H×D		45×90×66						45×90×79								
Mass (g)		350						370								
Optional accessory	Auxiliary contact block	○						○								
	Alarm contact block	○						○								
	Auxiliary and alarm contact block	○						○								
	Short-circuit alarm contact block	○						○								
	Shunt trip device	○						○								
	Undervoltage trip device	○						○								
External operating handle		–						○								
Standard		IEC 60947-1, 60947-2, 60947-4-1, UL 508, CSA C22.2 No.14, TÜV														

Note: *1 Adjustable thermal-magnetic trip type only

*2 When the breaking duty is once "0" in JEM 1195, the breaking capacity is 50kA.



○ Available

– Not available

DUO series Manual Motor Starters

Quick reference guide

■ 63AF types and ratings

Adjustable thermal-magnetic trip type		Standard breaking capacity BM3VSB-□						High breaking capacity BM3VHB-□ BM3VHBK-□														
Instantaneous trip type																						
		AF01-47						AF01-43														
Number of poles		3						3														
Handle type		Rotary						Rotary														
Rated current I_n (A)		10 to 63																				
Rated operational voltage U_e (V)		200 to 690																				
Rated frequency (Hz)		50/60																				
Rated insulation voltage U_i (V)		1000																				
Rated impulse withstand voltage U_{imp} (kV)		8																				
Utilization category		IEC 60947-2 Circuit breaker IEC 60947-4-1 Motor starter						Cat. A AC-3														
Trip class IEC 60947-4-1 *1		10																				
Instantaneous trip characteristic		13 × I_n max.																				
Power loss (total of 3-pole)		11W: $I_n=10$ to 32A 15W: $I_n=40$ to 50A 17W: $I_n=63$ A																				
Mechanical durability (operations)		50,000																				
Electrical durability (operations)		25,000																				
Max. operations per hour (motor start-up)		25																				
Phase-loss protection		Provided																				
Tripping state indication		Provided																				
Test trip function		Provided																				
Rated breaking capacity (kA)	Adjustable current range	240V	415V	460V	500V	690V	240V	415V	460V	500V	690V	240V	415V	460V	500V	690V						
	Code I_e : Min.–Max. (A)	230V	400V	440V		600V	230V	400V	440V		600V	230V	400V	440V		600V						
IEC 60947-2		I_{cu}	I_{cs}	I_{cu}	I_{cs}	I_{cu}	I_{cs}	I_{cu}	I_{cs}	I_{cu}	I_{cs}	I_{cu}	I_{cs}	I_{cu}	I_{cs}	I_{cu}	I_{cs}					
Replace the □ mark in the type number by current range codes.	P16	0.1–0.16	–	–	–	–	–	–	–	–	–	–	–	–	–	–	–					
	P25	0.16–0.25	–	–	–	–	–	–	–	–	–	–	–	–	–	–	–					
	P40	0.25–0.4	–	–	–	–	–	–	–	–	–	–	–	–	–	–	–					
	P63	0.4–0.63	–	–	–	–	–	–	–	–	–	–	–	–	–	–	–					
	001	0.63–1	–	–	–	–	–	–	–	–	–	–	–	–	–	–	–					
	1P6	1–1.6	–	–	–	–	–	–	–	–	–	–	–	–	–	–	–					
	2P5	1.6–2.5	–	–	–	–	–	–	–	–	–	–	–	–	–	–	–					
	004	2.5–4	–	–	–	–	–	–	–	–	–	–	–	–	–	–	–					
	6P3	4–6.3	–	–	–	–	–	–	–	–	–	–	–	–	–	–	–					
	010	6.3–10	100	100	100	100	15	12	10	8	4	3	100	100	100	100	50	38	50	38	6	5
	013	9–13	100	100	50	38	10	8	6	5	4	3	100	100	100	100	50	38	42	32	6	5
	016	11–16	100	100	25	19	10	8	6	5	4	3	100	100	50	38	50	38	12	9	5	4
	020	14–20	50	38	25	19	10	8	6	5	4	3	100	100	50	38	50	38	12	9	5	4
025	19–25	50	38	25	19	10	8	6	5	4	3	100	100	50	38	35*2	27	12	9	5	4	
032	24–32	50	38	25	19	10	8	6	5	4	3	100	100	50	38	35*2	27	10	8	5	4	
040	28–40	50	38	25	19	10	8	6	5	4	3	100	100	50	38	35*2	27	10	8	5	4	
050	35–50	50	38	25	19	10	8	6	5	4	3	100	100	50	38	35*2	27	10	8	5	4	
063	45–63	50	38	25	19	10	8	6	5	4	3	100	100	50	38	35*2	27	10	8	5	4	
Dimensions (mm) W×H×D		55×110×96																				
Mass (g)		780																				
Optional accessory	Auxiliary contact block	○																				
	Alarm contact block	○																				
	Auxiliary and alarm contact block	○																				
	Short-circuit alarm contact block	○																				
	Shunt trip device	○																				
	Undervoltage trip device	○																				
	External operating handle	○																				
Standard		IEC 60947-1, 60947-2, 60947-4-1, UL 508, CSA C22.2 No.14, TÜV																				



Note: * 1 Adjustable thermal-magnetic trip type only

○ Available

– Not available

* 2 When the breaking duty is once "0" in JEM 1195, the breaking capacity is 50kA.

■ 32AF types and ratings, with ring terminal connection

Adjustable thermal-magnetic trip type Instantaneous trip type		Standard breaking capacity BM3RSR-□  KKD05-197						High breaking capacity BM3RHR-□ BM3RHRK-□  KKD05-198										
Number of poles		3						3										
Handle type		Rocker						Rotary										
Rated current I _n (A)		0.16 to 32																
Rated operational voltage U _e (V)		200 to 690																
Rated frequency (Hz)		50/60																
Rated insulation voltage U _i (V)		690																
Rated impulse withstand voltage U _{imp} (kV)		6																
Utilization category IEC 60947-2 Circuit breaker		Cat. A																
IEC 60947-4-1 Motor starter		AC-3																
Trip class IEC 60947-4-1 *1		10																
Instantaneous trip characteristic		13 × I _n max.																
Power loss (total of 3-pole)		7W: I _n =0.16 to 25A 8.5W: I _n =32A																
Mechanical durability (operations)		100,000: I _n =0.16 to 25A 70,000: I _n =32A																
Electrical durability (operations)		100,000: I _n =0.16 to 25A 70,000: I _n =32A																
Max. operations per hour (motor start-up)		25																
Phase-loss protection		Provided																
Tripping state indication		Provided																
Test trip function		Provided																
Rated breaking capacity (kA)	Adjustable current range	240V	415V	460V	500V	690V	240V	415V	460V	500V	690V	240V	415V	460V	500V	690V		
	Code I _e : Min.–Max. (A)	230V	400V	440V		600V	230V	400V	440V		600V	230V	400V	440V		600V		
IEC 60947-2 <i>Replace the □ mark in the type number by current range codes.</i>		I _{cu}	I _{cs}	I _{cu}	I _{cs}	I _{cu}	I _{cs}	I _{cu}	I _{cs}	I _{cu}	I _{cs}	I _{cu}	I _{cs}	I _{cu}	I _{cs}	I _{cu}	I _{cs}	
	P16	0.1–0.16	100	100	100	100	100	100	100	100	100	100	100	100	100	100	100	100
	P25	0.16–0.25	100	100	100	100	100	100	100	100	100	100	100	100	100	100	100	100
	P40	0.25–0.4	100	100	100	100	100	100	100	100	100	100	100	100	100	100	100	100
	P63	0.4–0.63	100	100	100	100	100	100	100	100	100	100	100	100	100	100	100	100
	001	0.63–1	100	100	100	100	100	100	100	100	100	100	100	100	100	100	100	100
	1P6	1–1.6	100	100	100	100	100	100	100	100	100	100	100	100	100	100	100	100
	2P5	1.6–2.5	100	100	100	100	100	100	3	2	100	100	100	100	100	100	8	6
	004	2.5–4	100	100	100	100	100	100	3	2	100	100	100	100	100	100	8	6
	6P3	4–6.3	100	100	100	100	50	38	50	38	3	2	100	100	100	100	100	100
	010	6.3–10	100	100	100	100	15	11	10	8	3	2	100	100	50	38	50	38
	013	9–13	100	100	50	38	10	8	6	5	3	2	100	100	50	38	42	32
	016	11–16	100	100	25	19	10	8	6	5	3	2	100	100	50	38	35 ^{*2}	27
	020	14–20	50	38	25	19	10	8	6	5	3	2	100	100	50	38	35 ^{*2}	27
	025	19–25	50	38	25	19	10	8	6	5	3	2	100	100	50	38	35 ^{*2}	27
	032	24–32	50	38	25	19	10	8	6	5	3	2	100	100	50	38	35 ^{*2}	27
040	28–40	–	–	–	–	–	–	–	–	–	–	–	–	–	–	–	–	
050	35–50	–	–	–	–	–	–	–	–	–	–	–	–	–	–	–	–	
063	45–63	–	–	–	–	–	–	–	–	–	–	–	–	–	–	–	–	
Dimensions (mm) W×H×D		45×90×66						45×90×79										
Mass (g)		350						370										
Optional accessory	Auxiliary contact block	○						○										
	Alarm contact block	○						○										
	Auxiliary and alarm contact block	○						○										
	Short-circuit alarm contact block	○						○										
	Shunt trip device	○						○										
	Undervoltage trip device	○						○										
	External operating handle	–						○										
Standard		IEC 60947-1, 60947-2, 60947-4-1, UL 508, CSA C22.2 No.14, TÜV																

Note: *1 Adjustable thermal-magnetic trip type only

*2 When the breaking duty is once "0" in JEM 1195, the breaking capacity is 50kA.

○ Available

– Not available

DUO series Manual Motor Starters

Adjustable thermal-magnetic trip types

Adjustable thermal-magnetic trip types

■ Features

- A wide rated operational current range of up to 32A for the 45mm wide and 63A for the 55mm wide starters.
- ON/OFF and trip indications ensure instant status recognition.
- Suitable for 3-phase motors up to 30kW at 440V AC, AC-3.
- Accessories like auxiliary contact blocks, shunt trip devices, and undervoltage trip devices have been standardized for the 45mm and 55mm wide frame sizes of the BM3R and BM3V.
- Enclosures and external operating handles are available as optional accessories.

■ Standards

IEC 60947-1, 60947-2, 60947-4-1, UL 508, CSA C22.2 No.14, TÜV, CCC

■ Types and ratings

• 32AF standard breaking capacity, rocker handle types

Max. motor capacity and full-load current 3-phase *1				Rated current *2 In (A)	Thermal current setting range Ie (A)	Instantaneous trip current (A)	Rated breaking capacity Icu (kA)			Type
200-240V AC (kW) (A)		380-440V AC (kW) (A)					240V AC	415V AC	440V AC	
–	–	0.02	0.1	0.16	0.1–0.16	2.1	100	100	100	BM3RSB-P16
0.03	0.24	0.06	0.21	0.25	0.16–0.25	3.3	100	100	100	BM3RSB-P25
0.06	0.37	0.1	0.34	0.4	0.25–0.4	5.2	100	100	100	BM3RSB-P40
0.06	0.37	0.12	0.41	0.63	0.4–0.63	8.2	100	100	100	BM3RSB-P63
0.1	0.68	0.2	0.65	1	0.63–1	13	100	100	100	BM3RSB-001
0.2	1.3	0.4	1.15	1.6	1–1.6	20.8	100	100	100	BM3RSB-1P6
0.4	2.3	0.75	1.8	2.5	1.6–2.5	32.5	100	100	100	BM3RSB-2P5
0.75	3.6	1.5	3.1	4	2.5–4	52	100	100	100	BM3RSB-004
1.5	6.1	2.2	4.6	6.3	4–6.3	81.9	100	100	50	BM3RSB-6P3
2.2	9.2	3.7	7.5	10	6.3–10	130	100	100	15	BM3RSB-010
2.2	9.2	5.5	11.5	13	9–13	169	100	50	10	BM3RSB-013
3.7	15	7.5	14.5	16	11–16	208	100	25	10	BM3RSB-016
3.7	15	7.5	14.5	20	14–20	260	50	25	10	BM3RSB-020
5.5	22.5	11	21	25	19–25	325	50	25	10	BM3RSB-025
7.5	29	15	27.5	32	24–32	416	50	25	10	BM3RSB-032

• 32AF high breaking capacity, rotary handle types

Max. motor capacity and full-load current 3-phase *1				Rated current *2 In (A)	Thermal current setting range Ie (A)	Instantaneous trip current (A)	Rated breaking capacity Icu (kA)			Type
200-240V AC (kW) (A)		380-440V AC (kW) (A)					240V AC	415V AC	440V AC	
–	–	0.02	0.1	0.16	0.1–0.16	2.1	100	100	100	BM3RHB-P16
0.03	0.24	0.06	0.21	0.25	0.16–0.25	3.3	100	100	100	BM3RHB-P25
0.06	0.37	0.1	0.34	0.4	0.25–0.4	5.2	100	100	100	BM3RHB-P40
0.06	0.37	0.12	0.41	0.63	0.4–0.63	8.2	100	100	100	BM3RHB-P63
0.1	0.68	0.2	0.65	1	0.63–1	13	100	100	100	BM3RHB-001
0.2	1.3	0.4	1.15	1.6	1–1.6	20.8	100	100	100	BM3RHB-1P6
0.4	2.3	0.75	1.8	2.5	1.6–2.5	32.5	100	100	100	BM3RHB-2P5
0.75	3.6	1.5	3.1	4	2.5–4	52	100	100	100	BM3RHB-004
1.5	6.1	2.2	4.6	6.3	4–6.3	81.9	100	100	100	BM3RHB-6P3
2.2	9.2	3.7	7.5	10	6.3–10	130	100	100	50	BM3RHB-010
2.2	9.2	5.5	11.5	13	9–13	169	100	100	50	BM3RHB-013
3.7	15	7.5	14.5	16	11–16	208	100	50	35	BM3RHB-016
3.7	15	7.5	14.5	20	14–20	260	100	50	35	BM3RHB-020
5.5	22.5	11	21	25	19–25	325	100	50	35	BM3RHB-025
7.5	29	15	27.5	32	24–32	416	100	50	35	BM3RHB-032

Notes: *1 Motor full-load currents are based on FUJI's standard type totally-enclosed induction motors.

*2 Max. thermal current setting value

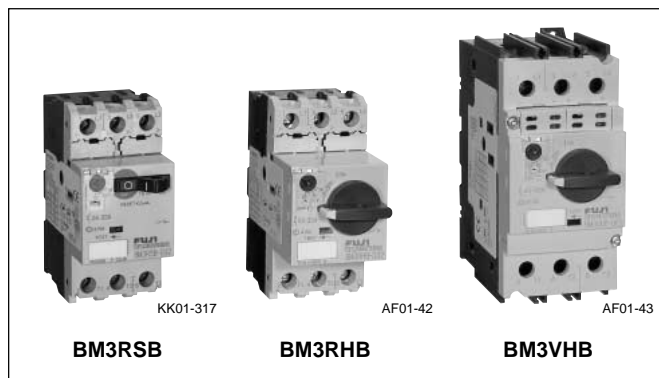

• **63AF standard breaking capacity, rotary handle types**

Max. motor capacity and full-load current 3-phase *1				Rated current *2 In (A)	Thermal current setting range Ie (A)	Instantaneous trip current (A)	Rated breaking capacity Icu (kA)			Type
200-240V AC (kW) (A)		380-440V AC (kW) (A)					240V AC	415V AC	440V AC	
2.2	9.2	3.7	7.5	10	6.3-10	130	100	100	15	BM3VSB-010
2.2	9.2	5.5	11.5	13	9-13	169	100	50	10	BM3VSB-013
3.7	15	7.5	14.5	16	11-16	208	100	25	10	BM3VSB-016
3.7	15	7.5	14.5	20	14-20	260	50	25	10	BM3VSB-020
5.5	22.5	11	21	25	19-25	325	50	25	10	BM3VSB-025
7.5	29	15	27.5	32	24-32	416	50	25	10	BM3VSB-032
7.5	29	18.5	34	40	28-40	520	50	25	10	BM3VSB-040
11	42	22	39	50	35-50	650	50	25	10	BM3VSB-050
15	55	30	54	63	45-63	819	50	25	10	BM3VSB-063

• **63AF high breaking capacity, rotary handle types**

Max. motor capacity and full-load current 3-phase *1				Rated current *2 In (A)	Thermal current setting range Ie (A)	Instantaneous trip current (A)	Rated breaking capacity Icu (kA)			Type
200-240V AC (kW) (A)		380-440V AC (kW) (A)					240V AC	415V AC	440V AC	
2.2	9.2	3.7	7.5	10	6.3-10	130	100	100	50	BM3VHB-010
2.2	9.2	5.5	11.5	13	9-13	169	100	100	50	BM3VHB-013
3.7	15	7.5	14.5	16	11-16	208	100	50	50	BM3VHB-016
3.7	15	7.5	14.5	20	14-20	260	100	50	50	BM3VHB-020
5.5	22.5	11	21	25	19-25	325	100	50	35	BM3VHB-025
7.5	29	15	27.5	32	24-32	416	100	50	35	BM3VHB-032
7.5	29	18.5	34	40	28-40	520	100	50	35	BM3VHB-040
11	42	22	39	50	35-50	650	100	50	35	BM3VHB-050
15	55	30	54	63	45-63	819	100	50	35	BM3VHB-063

Notes: *1 Motor full-load currents are based on FUJI's standard type totally-enclosed induction motors.
*2 Max. thermal current setting value

■ **Type number nomenclature**

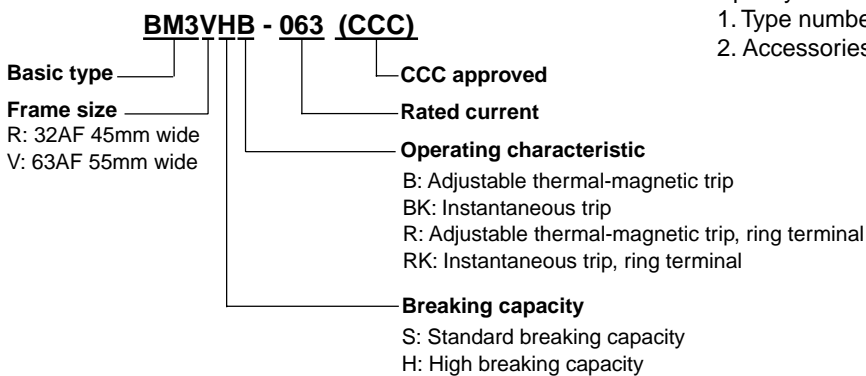

■ **Ordering information**

- Specify the following:
1. Type number
 2. Accessories if required

DUO series Manual Motor Starters

Instantaneous trip types

Instantaneous trip types

■ Features

- Instantaneous trip type for short-circuit or overcurrent protection of three-phase motors up to 63A (240V AC, 15kW, or 440V AC, 30kW).
- A motor overload protection function is not provided. Protecting the motor circuits is possible by using the starter together with a thermal overload relay that is matched to the thermal characteristics and startup time of the motor.
- Two modules, 45mm or 55mm wide, cover current ratings from 0.1 to 63A.
RHBK: 45mm wide, rated current of 0.1 to 32A
VHBK: 55mm wide, rated current of 6.3 to 63A
- Rotary handle
- Versatile accessories
Internal and external auxiliary contact blocks, alarm contact block
Short-circuit alarm contact block
Shunt trip device
Undervoltage trip device

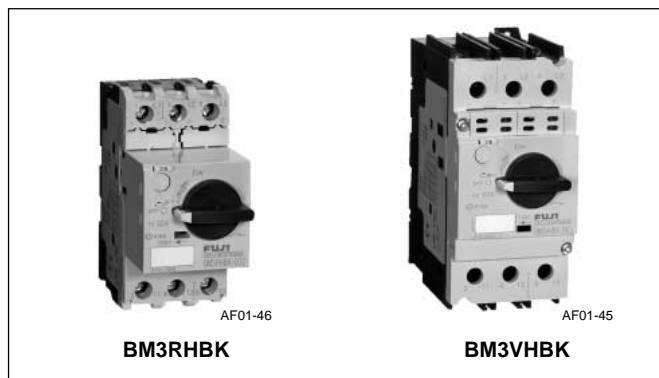

■ Standards

IEC 60947-1, 60947-2, 60947-4-1, UL 508
CSA C22.2 No.14, TÜV, CCC

■ Types and ratings

• 32AF high breaking capacity, rotary handle type

Max. motor capacity and full-load current 3-phase *				Rated current In (A)	Instantaneous trip current (A)	Rated breaking capacity Icu (kA)			Type
200-240V AC		380-440V AC				240V AC	415V AC	440V AC	
(kW)	(A)	(kW)	(A)						
–	–	0.02	0.1	0.16	2.1	100	100	100	BM3RHBK-P16
0.03	0.24	0.06	0.21	0.25	3.3	100	100	100	BM3RHBK-P25
0.06	0.37	0.1	0.34	0.4	5.2	100	100	100	BM3RHBK-P40
0.06	0.37	0.12	0.41	0.63	8.2	100	100	100	BM3RHBK-P63
0.1	0.68	0.2	0.65	1	13	100	100	100	BM3RHBK-001
0.2	1.3	0.4	1.15	1.6	20.8	100	100	100	BM3RHBK-1P6
0.4	2.3	0.75	1.8	2.5	32.5	100	100	100	BM3RHBK-2P5
0.75	3.6	1.5	3.1	4	52	100	100	100	BM3RHBK-004
1.5	6.1	2.2	4.6	6.3	81.9	100	100	100	BM3RHBK-6P3
2.2	9.2	3.7	7.5	10	130	100	100	50	BM3RHBK-010
2.2	9.2	5.5	11.5	13	169	100	100	50	BM3RHBK-013
3.7	15	7.5	14.5	16	208	100	50	35	BM3RHBK-016
3.7	15	7.5	14.5	20	260	100	50	35	BM3RHBK-020
5.5	22.5	11	21	25	325	100	50	35	BM3RHBK-025
7.5	29	15	27.5	32	416	100	50	35	BM3RHBK-032

Notes: * Motor full-load currents are based on FUJI's standard type totally-enclosed induction motors.

- Select appropriate thermal overload relay for starter.

• 63AF high breaking capacity, rotary handle type

Max. motor capacity and full-load current 3-phase *				Rated current In (A)	Instantaneous trip current (A)	Rated breaking capacity Icu (kA)			Type
200-240V AC		380-440V AC				240V AC	415V AC	440V AC	
(kW)	(A)	(kW)	(A)						
2.2	9.2	3.7	7.5	10	130	100	100	50	BM3VHBK-010
2.2	9.2	5.5	11.5	13	169	100	100	50	BM3VHBK-013
3.7	15	7.5	14.5	16	208	100	50	50	BM3VHBK-016
3.7	15	7.5	14.5	20	260	100	50	50	BM3VHBK-020
5.5	22.5	11	21	25	325	100	50	35	BM3VHBK-025
7.5	29	15	27.5	32	416	100	50	35	BM3VHBK-032
7.5	29	18.5	34	40	520	100	50	35	BM3VHBK-040
11	42	22	39	50	650	100	50	35	BM3VHBK-050
15	55	30	54	63	819	100	50	35	BM3VHBK-063

Notes: *1 Motor full-load currents are based on FUJI's standard type totally-enclosed induction motors.

- Select appropriate thermal overload relay for starter.

DUO series Manual Motor Starters

Ring terminal connection types

Adjustable thermal-magnetic trip types

Ring terminal connection types Adjustable thermal-magnetic trip types

■ Features

- Similar to FUJI MCCBs, the new type allows easy mounting and removal of the terminal cover, and up to two ring crimp terminals can be connected from the upper terminal part.
- Straight wiring connection is also possible in addition to ring terminal connection.
- The BM3RSR (0.16 to 32A rocker handle types) and BM3RHR (0.16 to 32A rotary handle types) are available.
- All optional accessories for standard manual motor starters can be mounted.
- The series conforms to IEC, UL and JIS standards, as do the standard manual motor starters.
- Crimp terminal insulation and a long terminal cover conforming to UL508 type E and F standards are available. (Purchased separately.)



■ Types and ratings

• 32AF standard breaking capacity, rocker handle types

Max. motor capacity and full-load current 3-phase *1				Rated current *2 In (A)	Thermal current setting range Ie (A)	Instantaneous trip current (A)	Rated breaking capacity Icu (kA)			Type
200-240V AC (kW) (A)		380-440V AC (kW) (A)					240V AC	415V AC	440V AC	
–	–	0.02	0.1	0.16	0.1–0.16	2.1	100	100	100	BM3RSR-P16
0.03	0.24	0.06	0.21	0.25	0.16–0.25	3.3	100	100	100	BM3RSR-P25
0.06	0.37	0.1	0.34	0.4	0.25–0.4	5.2	100	100	100	BM3RSR-P40
0.06	0.37	0.12	0.41	0.63	0.4–0.63	8.2	100	100	100	BM3RSR-P63
0.1	0.68	0.2	0.65	1	0.63–1	13	100	100	100	BM3RSR-001
0.2	1.3	0.4	1.15	1.6	1–1.6	20.8	100	100	100	BM3RSR-1P6
0.4	2.3	0.75	1.8	2.5	1.6–2.5	32.5	100	100	100	BM3RSR-2P5
0.75	3.6	1.5	3.1	4	2.5–4	52	100	100	100	BM3RSR-004
1.5	6.1	2.2	4.6	6.3	4–6.3	81.9	100	100	50	BM3RSR-6P3
2.2	9.2	3.7	7.5	10	6.3–10	130	100	100	15	BM3RSR-010
2.2	9.2	5.5	11.5	13	9–13	169	100	50	10	BM3RSR-013
3.7	15	7.5	14.5	16	11–16	208	100	25	10	BM3RSR-016
3.7	15	7.5	15	20	14–20	260	50	25	10	BM3RSR-020
5.5	22.5	11	21	25	19–25	325	50	25	10	BM3RSR-025
7.5	29	15	27.5	32	24–32	416	50	25	10	BM3RSR-032

Notes: *1 Motor full-load currents are based on FUJI's standard type totally-enclosed induction motors.
*2 Max. thermal current setting value

• 32AF high breaking capacity, rotary handle types

Max. motor capacity and full-load current 3-phase *1				Rated current *2 In (A)	Thermal current setting range Ie (A)	Instantaneous trip current (A)	Rated breaking capacity Icu (kA)			Type
200-240V AC (kW) (A)		380-440V AC (kW) (A)					240V AC	415V AC	440V AC	
–	–	0.02	0.1	0.16	0.1–0.16	2.1	100	100	100	BM3RHR-P16
0.03	0.24	0.06	0.21	0.25	0.16–0.25	3.3	100	100	100	BM3RHR-P25
0.06	0.37	0.1	0.34	0.4	0.25–0.4	5.2	100	100	100	BM3RHR-P40
0.06	0.37	0.12	0.41	0.63	0.4–0.63	8.2	100	100	100	BM3RHR-P63
0.1	0.68	0.2	0.65	1	0.63–1	13	100	100	100	BM3RHR-001
0.2	1.3	0.4	1.15	1.6	1–1.6	20.8	100	100	100	BM3RHR-1P6
0.4	2.3	0.75	1.8	2.5	1.6–2.5	32.5	100	100	100	BM3RHR-2P5
0.75	3.6	1.5	3.1	4	2.5–4	52	100	100	100	BM3RHR-004
1.5	6.1	2.2	4.6	6.3	4–6.3	81.9	100	100	100	BM3RHR-6P3
2.2	9.2	3.7	7.5	10	6.3–10	130	100	100	50	BM3RHR-010
2.2	9.2	5.5	11.5	13	9–13	169	100	100	50	BM3RHR-013
3.7	15	7.5	14.5	16	11–16	208	100	50	35	BM3RHR-016
3.7	15	7.5	14.5	20	14–20	260	100	50	35	BM3RHR-020
5.5	22.5	11	21	25	19–25	325	100	50	35	BM3RHR-025
7.5	29	15	27.5	32	24–32	416	100	50	35	BM3RHR-032

Notes: *1 Motor full-load currents are based on FUJI's standard type totally-enclosed induction motors.
*2 Max. thermal current setting value

DUO series Manual Motor Starters

Ring terminal connection types

Instantaneous trip types

• 32AF high breaking capacity, rotary handle type

Max. motor capacity and full-load current 3-phase *1				Rated current In (A)	Instantaneous trip current (A)	Rated breaking capacity Icu (kA)			Type
200-240V AC (kW) (A)		380-440V AC (kW) (A)				240V AC	415V AC	440V AC	
–	–	0.02	0.1	0.16	2.1	100	100	100	BM3RHRK-P16
0.03	0.24	0.06	0.21	0.25	3.3	100	100	100	BM3RHRK-P25
0.06	0.37	0.1	0.34	0.4	5.2	100	100	100	BM3RHRK-P40
0.06	0.37	0.12	0.41	0.63	8.2	100	100	100	BM3RHRK-P63
0.1	0.68	0.2	0.65	1	13	100	100	100	BM3RHRK-001
0.2	1.3	0.4	1.15	1.6	20.8	100	100	100	BM3RHRK-1P6
0.4	2.3	0.75	1.8	2.5	32.5	100	100	100	BM3RHRK-2P5
0.75	3.6	1.5	3.1	4	52	100	100	100	BM3RHRK-004
1.5	6.1	2.2	4.6	6.3	81.9	100	100	100	BM3RHRK-6P3
2.2	9.2	3.7	7.5	10	130	100	100	50	BM3RHRK-010
2.2	9.2	5.5	11.5	13	169	100	100	50	BM3RHRK-013
3.7	15	7.5	14.5	16	208	100	50	35	BM3RHRK-016
3.7	15	7.5	14.5	20	260	100	50	35	BM3RHRK-020
5.5	22.5	11	21	25	325	100	50	35	BM3RHRK-025
7.5	29	15	27.5	32	416	100	50	35	BM3RHRK-032

Notes: *1 Motor full-load currents are based on FUJI's standard type totally-enclosed induction motors.

*2 Max. thermal current setting value

■ Wirings

	Wire size (mm ²)	Ring crimp terminal max. width (mm)	Terminal screw	Tightening torque (N·m)
Line side	1 to 8	11 (R1.25-4 to R8-4)	M4	2
Load side	1 to 8	11 (R1.25-4 to R8-4)	M4	2

■ **UL listed**

FUJI MMS is certified for Group Installation according to UL508.

When it is used with a specific current rated BCP (Branch Circuit Protective Device) such as MCCB and Fuse, two or more motors can be connected to one branch circuit as in NEC 430.53.

The followings are some of the major rules for this application.

1. The Conductor size to the motor shall be the same as the branch circuit.

2. The Conductor size to the motor shall not be less than 1/3 of the branch circuit and the length from the BCP to the MMS must not be more than 7.5m (25 feet).

3. The MMS must be "Suitable for tap conductor Protection" and the Conductor size between the BCP and MMS shall not be less than 1/10 of the BCP and the length from the BCP to the MMS must not be more than 3m (10 feet).

4. The rating of the Fuse or MCCB must be smaller than the following table.

BM3RSB, BM3RSR

Adjustable current range Ie (A)	3-pole motor capacity in horsepower (HP)				Group installation			Max. Fuse / MCCB Rated current (A)
	AC				Breaking capacity (kA)			
	200–208V	220–240V	440–480V	550–600V	240V AC	480V AC	600V AC	
0.1–0.16	–	–	–	–	100	50	10	500
0.16–0.25	–	–	–	–	100	50	10	500
0.25–0.4	–	–	–	–	100	50	10	500
0.4–0.63	–	–	–	–	100	50	10	500
0.63–1	–	–	1/2	1/2	100	50	10	500
1–1.6	1/4	1/3	3/4	3/4	100	50	10	500
1.6–2.5	1/2	1/2	1	1–1/2	100	50	10	500
2.5–4	3/4	3/4	2	3	100	50	10	500
4–6.3	1	1–1/2	3	5	100	50	10	500
6.3–10	2	3	5	7–1/2	100	22	10	500
9–13	3	3	7–1/2	10	100	22	10	500
11–16	3	5	10	10	100	22	10	500
14–20	5	5	10	15	50	22	10	500
19–25	7–1/2	7–1/2	15	20	50	22	10	500
24–32	10	10	20	30	50	22	10	500

BM3RHB, BM3RHR

Adjustable current range Ie (A)	3-pole motor capacity in horsepower (HP)				Group installation			Max. Fuse / MCCB Rated current (A)
	AC				Breaking capacity (kA)			
	200–208V	220–240V	440–480V	550–600V	240V AC	480V AC	600V AC	
0.1–0.16	–	–	–	–	100	50	10	500
0.16–0.25	–	–	–	–	100	50	10	500
0.25–0.4	–	–	–	–	100	50	10	500
0.4–0.63	–	–	–	–	100	50	10	500
0.63–1	–	–	1/2	1/2	100	50	10	500
1–1.6	1/4	1/3	3/4	3/4	100	50	10	500
1.6–2.5	1/2	1/2	1	1–1/2	100	50	10	500
2.5–4	3/4	3/4	2	3	100	50	10	500
4–6.3	1	1–1/2	3	5	100	50	10	500
6.3–10	2	3	5	7–1/2	100	50	10	500
9–13	3	3	7–1/2	10	100	50	10	500
11–16	3	5	10	10	100	50	10	500
14–20	5	5	10	15	100	50	10	500
19–25	7–1/2	7–1/2	15	20	100	50	10	500
24–32	10	10	20	30	100	50	10	500

BM3VSB, BM3VHB

Adjustable current range Ie (A)	3-pole motor capacity in horsepower (HP)				Group installation			Max. Fuse / MCCB Rated current (A)
	AC				Breaking capacity (kA)			
	200–208V	220–240V	440–480V	550–600V	240V AC	480V AC *	600V AC	
6.3–10	2	3	5	7–1/2	100	50 (22)	10	600
9–13	3	3	7–1/2	10	100	50 (22)	10	600
11–16	3	5	10	10	100	50 (22)	10	600
14–20	5	5	10	15	100	50 (22)	10	600
19–25	7–1/2	7–1/2	15	20	100	50 (22)	10	600
24–32	10	10	20	30	100	50 (22)	10	600
28–40	10	10	30	30	100	50 (22)	10	600
35–50	15	15	30	40	100	50 (22)	10	600
45–63	20	20	40	60	100	50 (22)	10	600

* Value in () is for BM3VSB.

DUO series Manual Motor Starters

Characteristics curves

■ Characteristics curves

• BM3RSB, RHB, RSR, RHR

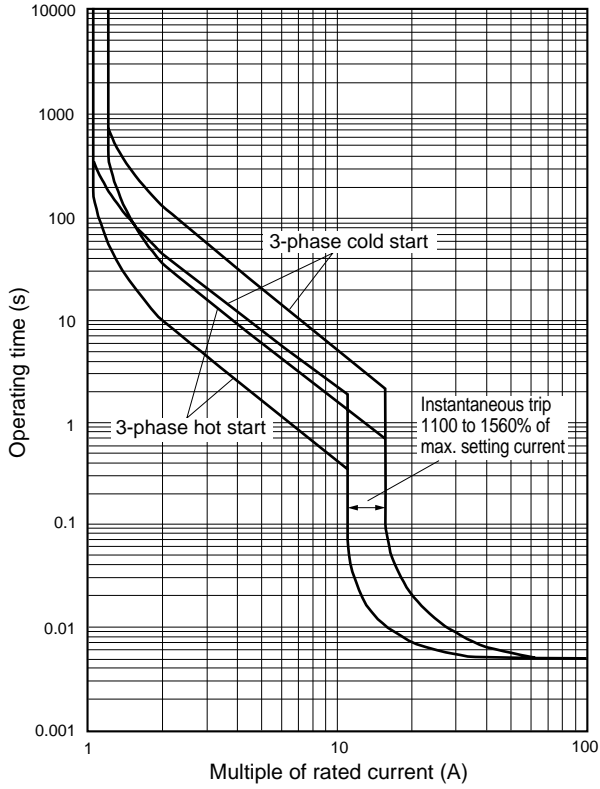

• BM3VSB, VHB

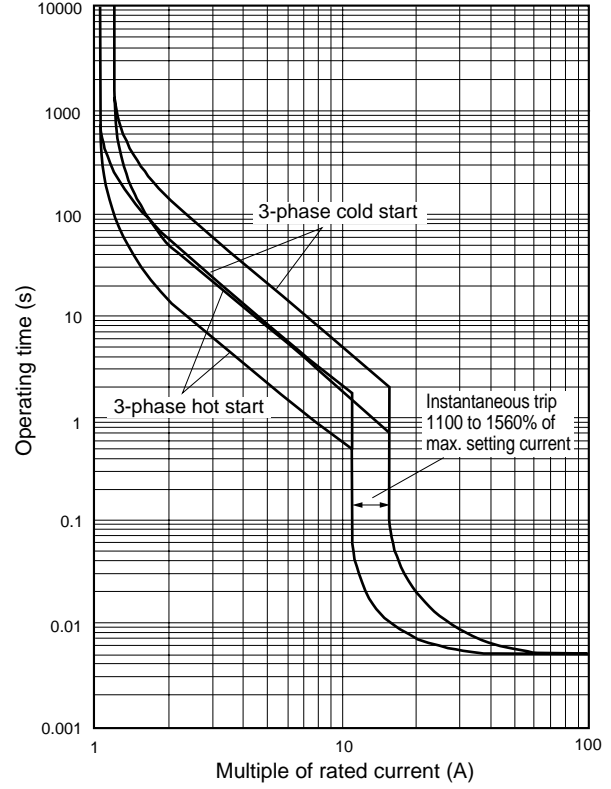

• BM3RHBK, RHRK

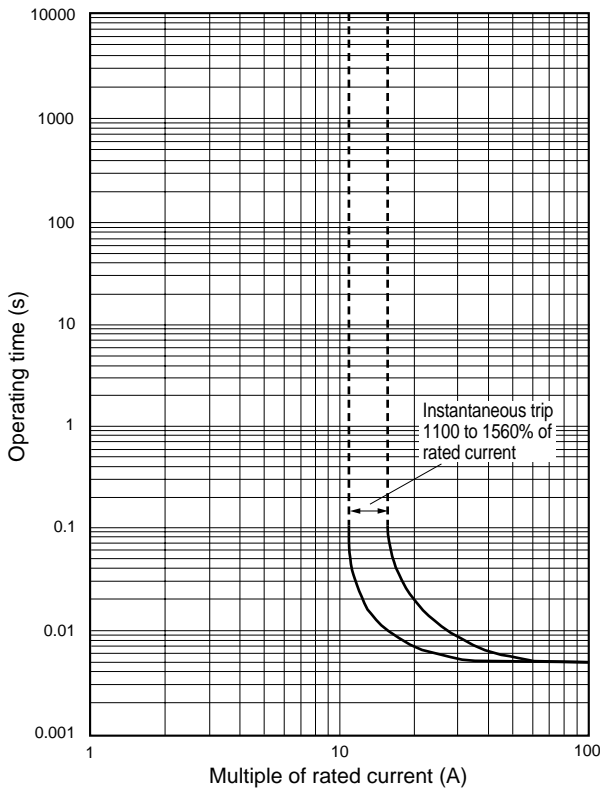

• BM3VHBK

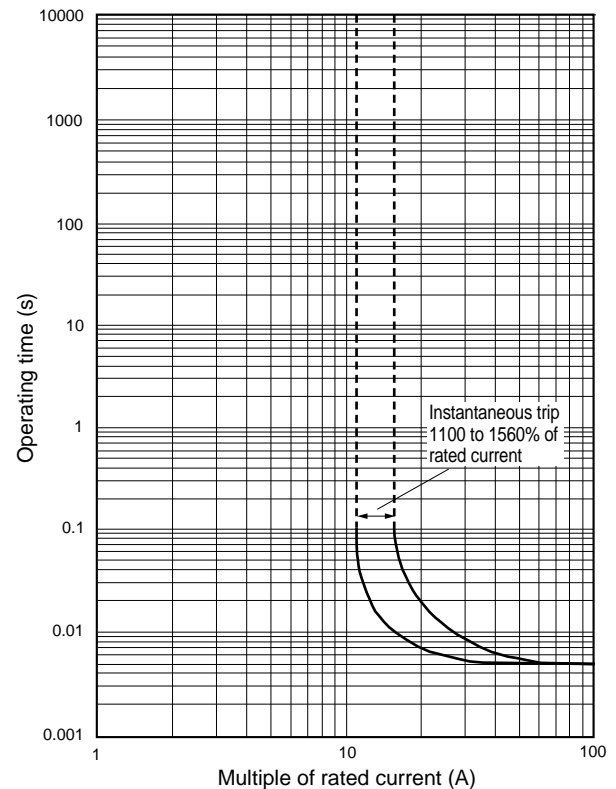

Optional accessories

■ Features

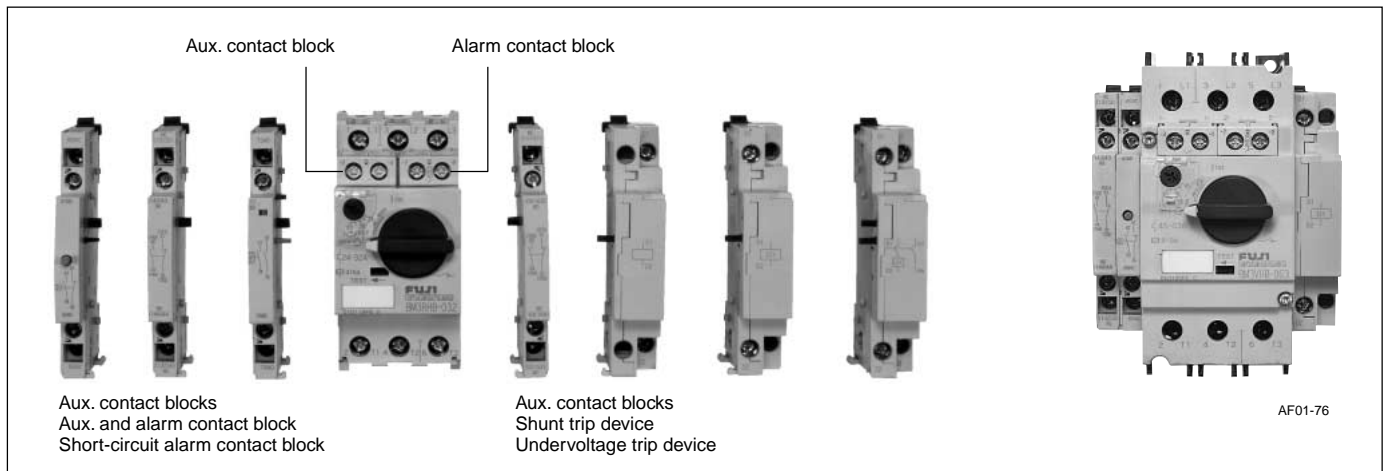

- Auxiliary contact blocks, alarm contact blocks, and shunt/undervoltage trip devices can be used with BM3R (45mm wide) and BM3V (55mm wide) frames.
- Accessories are easily mounted.
- Internally mountable auxiliary contact blocks and alarm contact blocks can be frontally mounted.
- Externally mountable auxiliary contact blocks can be

- mounted on either the right or left side.
- Shunt trip and undervoltage trip devices are available in a wide operating coil voltage range.
- Standard and emergency external handles are available.
- IP20 terminal cover prevents accidental finger touch to electrically charged parts.



■ Types and ratings

• Auxiliary contact blocks/W

Description	Starter type	Mounting	Contact arrangement	Type	Mass (g)
 AF01-60L  AF01-59, 01-58 These blocks are linked to the ON/OFF operation of the MMS. Up to two internally mountable contact blocks can be mounted to the right/left front, and up to two externally mountable contact blocks can be mounted to the right/left sides.	BM3R BM3V	Front	1NO 1NC	BZ0WIA BZ0WIB	9
		Left side	2NO 1NO+1NC 2NC	BZ0WUAAL BZ0WUABL BZ0WUBBL	45
		Right side	2NO 1NO+1NC 2NC	BZ0WUAAR BZ0WUABR BZ0WUBBR	45

• Alarm contact blocks/K

Description	Starter type	Mounting	Contact arrangement	Type	Mass (g)
 AF01-60R This block operates when the MMS trips due to overload, phase-loss, or short-circuit. It is not linked to the ON/OFF operation of the MMS. Note: Operation can be checked with the test trip function.	BM3R BM3V	Front (Right side only)	1NO 1NC	BZ0KIA BZ0KIB	9

DUO series Manual Motor Starters

Optional accessories

• Auxiliary and alarm contact blocks/WK

Description	Starter type	Mounting	Contact arrangement	Type	Mass (g)
 <p>AF01-57</p> <ul style="list-style-type: none"> This contact block combines auxiliary contact and alarm contact that operates in the event of an overload, phase-loss, or short-circuit. Alarm contact is not linked to the ON/OFF operation of the MMS. An alarm is displayed in the contact block's indicator when the alarm contact operates. <p>Note: Operation can be checked with the test trip function.</p>	BM3R BM3V	Left	1NO (Aux.)+ 1NO (Alarm)	BZ0WKUAA	45
			1NC (Aux.)+ 1NO (Alarm)	BZ0WKUBA	
			1NO (Aux.)+ 1NC (Alarm)	BZ0WKUAB	
			1NC (Aux.)+ 1NC (Alarm)	BZ0WKUBB	

• Short-circuit alarm contact blocks/KI

Description	Starter type	Mounting	Contact arrangement	Type	Mass (g)
 <p>AF01-56</p> <ul style="list-style-type: none"> The contacts operate only when the MMS has tripped due to a short-circuit. When these contacts operate, the blue reset button extends out, and a trip indication is displayed. The power to the MMS can be ready to be turned on after pressing the reset button. <p>Note: Operation can not be checked with the test trip function. Be sure to press the reset button before mounting to the MMS.</p>	BM3R BM3V	Left	1NO+1NC	BZ0TKUAB	45

• Shunt trip devices/F



Description	Starter type	Mounting	Coil voltage	Type	Mass (g)
 <p>AF01-55</p> <p>This device is used to remotely trip the MMS.</p> <p>Notes:</p> <ul style="list-style-type: none"> This device cannot be used together with an undervoltage trip device. When the MMS has been tripped with the shunt trip device, press the reset button before turning on the power. 	BM3R BM3V	Right	24V 50/60Hz 48V 60Hz 48V 50Hz/60V 60Hz	BZ0FAZU BZ0FBZU BZ0FCZU	115
			100V 50Hz/100–110V 60Hz 110–127V 50Hz/120V 60Hz 200V 50Hz/200–220V 60Hz 220–230V 50Hz/240–260V 60Hz 240V 50Hz/277V 60Hz	BZ0F1ZU BZ0FDZU BZ0FEZU BZ0FFZU BZ0FGZU	
			380–400V 50Hz/400–440V 60Hz 415–440V 50Hz/460–480V 60Hz 500V 50Hz/600V 60Hz 24–60V DC * 110–240V DC *	BZ0FHZU BZ0F4ZU BZ0FJZU BZ0FKZUD BZ0FLZUD	

Note: * The time rating of coil is 5s.

• Undervoltage trip devices/R



Description	Starter type	Mounting	Coil voltage	Type	Mass (g)
 <p>AF01-54</p> <p>R types This device automatically trips the MMS when the control circuit voltage drops below the specified value.</p> <p>Notes:</p> <ul style="list-style-type: none"> This device cannot be used together with a shunt trip device. When the MMS has been tripped with the undervoltage trip device, press the reset button before turning on the power. 	BM3R BM3V	Right	24V 50Hz 24V 60Hz 48V 50Hz 48V 60Hz	BZ0RAZ1U BZ0RAZ2U BZ0RBZ1U BZ0RBZU	115
			100V 50Hz/100–110V 60Hz 110–127V 50Hz/120V 60Hz 200V 50Hz/200–220V 60Hz 220–230V 50Hz/240–260V 60Hz 240V 50Hz/277V 60Hz	BZ0R1ZU BZ0RDZU BZ0REZU BZ0RFZU BZ0RGZU	
			380–400V 50Hz/400–440V 60Hz 415–440V 50Hz/460–480V 60Hz 500V 50Hz/600V 60Hz	BZ0RHZU BZ0R4ZU BZ0RJZU	

• Undervoltage trip device with early make contacts/Re



Description	Starter type	Mounting	Coil voltage	Type	Mass (g)
 <p>AF01-52</p> <p>This device automatically trips the MMS when the control circuit voltage drops below the specified value. The control circuit voltage can be turned completely off by turning off the MMS.</p> <p>Notes:</p> <ul style="list-style-type: none"> • This device cannot be used together with a shunt trip device. • When the MMS has been tripped with the undervoltage trip device, press the reset button before turning on the power. 	BM3RS	Right	24V 50Hz 24V 60Hz 48V 50Hz 48V 60Hz 100V 50Hz/100–110V 60Hz 110–127V 50Hz/120V 60Hz 200V 50Hz/200–220V 60Hz 220–230V 50Hz/240–260V 60Hz 240V 50Hz/277V 60Hz 380–400V 50Hz/400–440V 60Hz 415–440V 50Hz/460–480V 60Hz 500V 50Hz/600V 60Hz	BZ0RAZ1LKU BZ0RAZ2LKU BZ0RBZ1LKU BZ0RBZLKU BZ0R1ZLKU BZ0RDZLKU BZ0REZLKU BZ0RFZLKU BZ0RGZLKU BZ0RHZLKU BZ0R4ZLKU BZ0RJZLKU	115
	 <p>AF01-53</p>	BM3RH BM3V	Right	24V 50Hz 24V 60Hz 48V 50Hz 48V 60Hz 100V 50Hz/100–110V 60Hz 110–127V 50Hz/120V 60Hz 200V 50Hz/200–220V 60Hz 220–230V 50Hz/240–260V 60Hz 240V 50Hz/277V 60Hz 380–400V 50Hz/400–440V 60Hz 415–440V 50Hz/460–480V 60Hz 500V 50Hz/600V 60Hz	BZ0RAZ1LTU BZ0RAZ2LTU BZ0RBZ1LTU BZ0RBZLTU BZ0R1ZLTU BZ0RDZLTU BZ0REZLTU BZ0RFZLTU BZ0RGZLTU BZ0RHZLTU BZ0R4ZLTU BZ0RJZLTU

Note: Refer to page 02/24 for details on how this device operates with the MMS, and on its external connection.

• External operating handles

Description	Starter type	Handle type	Type	Mass (g)	
 <p>KK02-305</p>  <p>KK02-306</p> <ul style="list-style-type: none"> • Used to operate an MMS installed inside a panel, from the outside of the panel. • Equipped with an interlock mechanism that prevents someone from mistakenly opening the panel door when the MMS is in the ON state. • The shaft can be cut to match the distance between the MMS and the panel door. • Door interlock function • OFF lock function • Can be locked OFF with up to three padlocks. Note: Padlocks are to be provided by the customer. • Release screw allows the door to be opened with the handle in the ON position. • IP54 protection degree 	BM3RH	Standard (black)	BZ0VBBL	160	
			Emergency (red handle on yellow plate)	BZ0VYRL	160
		BM3V	Standard (black)	BZ0VBBM	160
			Emergency (red handle on yellow plate)	BZ0VYRM	160



• Others

Description	Starter type	Type	Mass (g)
<p>Push-in lug</p>  <p>Used for screw mounting.</p>	BM3R	BZ0SET (10 pcs)	2.0 piece
<p>Terminal cover for IP20</p>  <p>Prevents accidental finger touch to charged parts.</p>	BM3V	BZ0TCV (6 pcs)	0.6 piece
<p>Open space cover</p>  <p>KK02-39</p> <ul style="list-style-type: none"> • Used to cover the open space if an internally mountable accessory become unnecessary. • Mounts to either the left-front or right-front position. 	BM3R BM3V	BZ0CFG (10 pcs)	1.4 piece

DUO series Manual Motor Starters

Optional accessories

• Others

Description	Starter type	Type	Mass (g)
Power supply side terminal cover  <ul style="list-style-type: none"> When mounted on the power supply side and combined with the optional BZ0TKUAB short-circuit alarm contact block, the configuration conforms to UL508 type E and F standards. 	BM3RSB BM3RHB	BZ0TCRE	30 per piece
Long terminal cover  <p style="text-align: center;">KK04-059</p> <ul style="list-style-type: none"> Prevents exposure between crimp terminals and finger contact Mountable to both power supply and load sides Straight wiring connection is also possible in addition to ring terminal connection. When mounted on the power supply side and combined with the optional BZ0TKUAB short-circuit alarm contact block, the configuration conforms to UL508 type E and F standards. Minimum quantity: 2 pieces (1 set) 	BM3RSR BM3RHR	BZ0RCRE	11 per piece

■ Ratings of accessories

Accessory type		Auxiliary contact block/front	Auxiliary contact block/side	Alarm contact block	Aux. and alarm contact block	Short-circuit alarm contact block
		BZ0WI	BZ0WU	BZ0KI	BZ0WKU	BZ0TKUAB
Standard		IEC 60947-5-1, UL 508				
Rated operational current (A)	48V AC AC-15	5	6	5	6	6
	125V AC	3	4	3	4	4
	230V AC	1.5	4	1.5	4	4
	400V AC	—	2.2	—	2.2	2.2
	500V AC	—	1.5	—	1.5	1.5
	690V AC	—	0.6	—	0.6	0.6
	48V DC DC-13	1.38	5	1.38	5	5
110V DC	0.55	1.3	0.55	1.3	1.3	
220V DC	0.27	0.5	0.27	0.5	0.5	
Contact rating code UL 508		B300 Q300	A600 P300	B300 Q300	A600 P300	A600 P300
Min. voltage and current		17V 5mA				

Accessory type		Shunt trip device	Undervoltage device
		BZ0F	BZ0R
Standard		IEC 60947-1, UL 508	
Rated insulation voltage (V AC)	IEC 60947	690	
	UL 508	600	
Operation performance capability (operations)		5000	
Operating time (ms)		20	
Power consumption	Inrush (VA/W)	21/12	
	Shealed (VA/W)	8/1.2	
Voltage range	Tripping voltage (V)	0.7 to 1.1Ue	
	Closing voltage (V)	—	
Time rating of coil (s)		AC: Continuous	AC: Continuous
		DC: 5	DC: —

■ Available accessory configuration

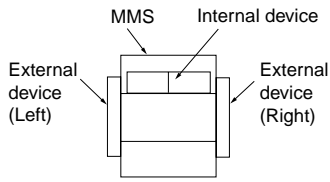

Internal devices

- Auxiliary contact block (W)
- Alarm contact block (K)

External devices

- Auxiliary contact (W2)
- Auxiliary and alarm contact block (WK)
- Short-circuit alarm contact block (KI)
- Shunt trip device (F)
- Undervoltage trip device (R) or undervoltage trip device with early make contacts (Re)

Adj. thermal-magnetic trip type MMS		BM3RSB, BM3RHB, BM3RSR, BM3RHR						BM3VSB, BM3VHB					
Instantaneous trip type MMS		BM3RHBK, BM3RHRK						BM3VHBK					
Internal accessory		<input type="checkbox"/>	<input type="checkbox"/>	<input type="checkbox"/>	<input checked="" type="checkbox"/>	<input type="checkbox"/>	<input type="checkbox"/>	<input type="checkbox"/>	<input type="checkbox"/>	<input type="checkbox"/>	<input checked="" type="checkbox"/>	<input type="checkbox"/>	<input type="checkbox"/>
			W	W	K	W+W	W+K		W	W	K	W+W	W+K
External accessory	W2 (Left)	<input type="checkbox"/>	<input type="checkbox"/>	<input type="checkbox"/>	<input checked="" type="checkbox"/>	<input type="checkbox"/>	<input type="checkbox"/>	<input type="checkbox"/>	<input type="checkbox"/>	<input type="checkbox"/>	<input checked="" type="checkbox"/>	<input type="checkbox"/>	<input type="checkbox"/>
	W2 (Right)	<input type="checkbox"/>	<input type="checkbox"/>	<input type="checkbox"/>	<input checked="" type="checkbox"/>	<input type="checkbox"/>	<input type="checkbox"/>	<input type="checkbox"/>	<input type="checkbox"/>	<input type="checkbox"/>	<input checked="" type="checkbox"/>	<input type="checkbox"/>	<input type="checkbox"/>
	WK (Left)	<input type="checkbox"/>	<input type="checkbox"/>	<input type="checkbox"/>	<input checked="" type="checkbox"/>	<input type="checkbox"/>	<input type="checkbox"/>	<input type="checkbox"/>	<input type="checkbox"/>	<input type="checkbox"/>	<input checked="" type="checkbox"/>	<input type="checkbox"/>	<input type="checkbox"/>
	KI (Left)	<input type="checkbox"/>	<input type="checkbox"/>	<input type="checkbox"/>	<input checked="" type="checkbox"/>	<input type="checkbox"/>	<input type="checkbox"/>	<input type="checkbox"/>	<input type="checkbox"/>	<input type="checkbox"/>	<input checked="" type="checkbox"/>	<input type="checkbox"/>	<input type="checkbox"/>
	F (Right)	<input type="checkbox"/>	<input type="checkbox"/>	<input type="checkbox"/>	<input checked="" type="checkbox"/>	<input type="checkbox"/>	<input type="checkbox"/>	<input type="checkbox"/>	<input type="checkbox"/>	<input type="checkbox"/>	<input checked="" type="checkbox"/>	<input type="checkbox"/>	<input type="checkbox"/>
	R (Re) (Right)	<input type="checkbox"/>	<input type="checkbox"/>	<input type="checkbox"/>	<input checked="" type="checkbox"/>	<input type="checkbox"/>	<input type="checkbox"/>	<input type="checkbox"/>	<input type="checkbox"/>	<input type="checkbox"/>	<input checked="" type="checkbox"/>	<input type="checkbox"/>	<input type="checkbox"/>
	W2 (Left)+F	<input type="checkbox"/>	<input type="checkbox"/>	<input type="checkbox"/>	<input checked="" type="checkbox"/>	<input type="checkbox"/>	<input type="checkbox"/>	<input type="checkbox"/>	<input type="checkbox"/>	<input type="checkbox"/>	<input checked="" type="checkbox"/>	<input type="checkbox"/>	<input type="checkbox"/>
	W2 (Left)+R (Re)	<input type="checkbox"/>	<input type="checkbox"/>	<input type="checkbox"/>	<input checked="" type="checkbox"/>	<input type="checkbox"/>	<input type="checkbox"/>	<input type="checkbox"/>	<input type="checkbox"/>	<input type="checkbox"/>	<input checked="" type="checkbox"/>	<input type="checkbox"/>	<input type="checkbox"/>
	WK+F	<input type="checkbox"/>	<input type="checkbox"/>	<input type="checkbox"/>	<input checked="" type="checkbox"/>	<input type="checkbox"/>	<input type="checkbox"/>	<input type="checkbox"/>	<input type="checkbox"/>	<input type="checkbox"/>	<input checked="" type="checkbox"/>	<input type="checkbox"/>	<input type="checkbox"/>
	WK+R (Re)	<input type="checkbox"/>	<input type="checkbox"/>	<input type="checkbox"/>	<input checked="" type="checkbox"/>	<input type="checkbox"/>	<input type="checkbox"/>	<input type="checkbox"/>	<input type="checkbox"/>	<input type="checkbox"/>	<input checked="" type="checkbox"/>	<input type="checkbox"/>	<input type="checkbox"/>
	KI+F	<input type="checkbox"/>	<input type="checkbox"/>	<input type="checkbox"/>	<input checked="" type="checkbox"/>	<input type="checkbox"/>	<input type="checkbox"/>	<input type="checkbox"/>	<input type="checkbox"/>	<input type="checkbox"/>	<input checked="" type="checkbox"/>	<input type="checkbox"/>	<input type="checkbox"/>
	KI+R (Re)	<input type="checkbox"/>	<input type="checkbox"/>	<input type="checkbox"/>	<input checked="" type="checkbox"/>	<input type="checkbox"/>	<input type="checkbox"/>	<input type="checkbox"/>	<input type="checkbox"/>	<input type="checkbox"/>	<input checked="" type="checkbox"/>	<input type="checkbox"/>	<input type="checkbox"/>
	W2 (Left)+W2 (Left)	<input type="checkbox"/>	<input type="checkbox"/>	<input type="checkbox"/>	<input checked="" type="checkbox"/>	<input type="checkbox"/>	<input type="checkbox"/>	<input type="checkbox"/>	<input type="checkbox"/>	<input type="checkbox"/>	<input checked="" type="checkbox"/>	<input type="checkbox"/>	<input type="checkbox"/>
	W2 (Left)+W2 (Right)	<input type="checkbox"/>	<input type="checkbox"/>	<input type="checkbox"/>	<input checked="" type="checkbox"/>	<input type="checkbox"/>	<input type="checkbox"/>	<input type="checkbox"/>	<input type="checkbox"/>	<input type="checkbox"/>	<input checked="" type="checkbox"/>	<input type="checkbox"/>	<input type="checkbox"/>

Note: Do not use an alarm contact block/K together with an undervoltage trip device with early make contacts/Re for the BM3RSB frame. If used together, the alarm contact block will not operate correctly when the MMS is automatically tripped due to undervoltage.

DUO series Manual Motor Starters

Optional accessories

Available accessory configuration (continued)

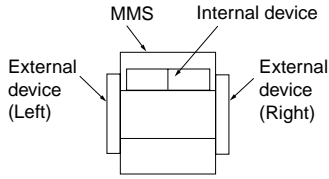

Internal devices

□ Auxiliary contact block (W) ◻ Alarm contact block (K)

External devices

◻ Auxiliary contact (W2) ◻ Auxiliary and alarm contact block (WK) ◻ Short-circuit alarm contact block (KI)
 ◻ Shunt trip device (F) ◻ Undervoltage trip device (R) or undervoltage trip device with early make contacts (Re)

Adj. thermal-magnetic trip type MMS	BM3RSB, BM3RHB, BM3RSR, BM3RSHR						BM3VSB, BM3VHB						
Instantaneous trip type MMS	BM3RHBK, BM3RHRK						BM3VHBK						
Internal accessory													
External accessory	W2 (Right)+ W2 (Right)												
	W2 (Left)+ WK												
	W2 (Right)+ WK												
	W2 (Left)+ KI												
	W2 (Right)+ KI												
	KI+WK												
	W2 (Left)+ W2 (Left)+F												
	W2 (Left)+ W2 (Left)+R (Re)												
	W2 (Left)+ WK+F												
	W2 (Left)+ WK+R (Re)												
	W2 (Left)+ KI+F												
	W2 (Left)+ KI+R (Re)												
	KI+WK+F												
	KI+WK+R (Re)												

Note: Do not use an alarm contact block/K together with an undervoltage trip device with early make contacts/Re for the BM3RSB frame. If used together, the alarm contact block will not operate correctly when the MMS is automatically tripped due to undervoltage.

■ Dimensions, mm

• Rocker handle types **BM3RSB, BM3RSR**

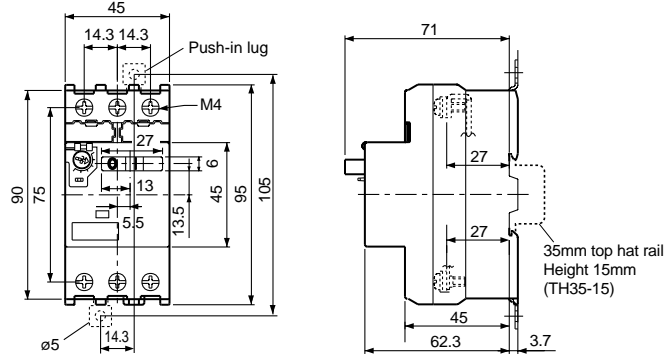

• Rotary handle types **BM3RHB, BM3RHR**

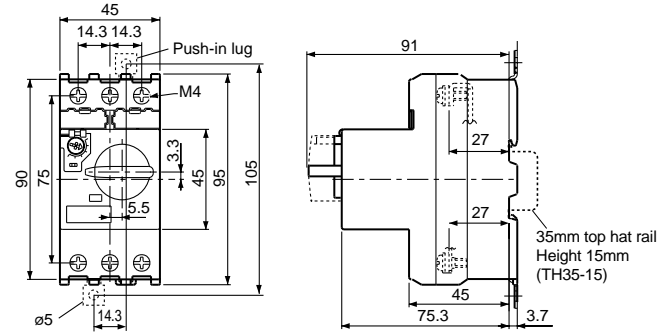

• Rotary handle types **BM3VSB, BM3VHB**

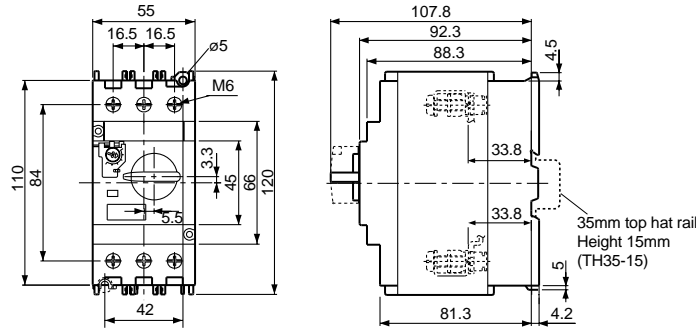

Accessories

• Auxiliary contact blocks, front mounting
BZ0WI

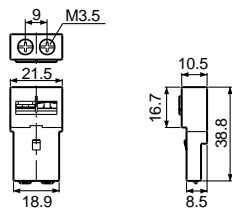

• Auxiliary contact blocks, side mounting
BZ0WU

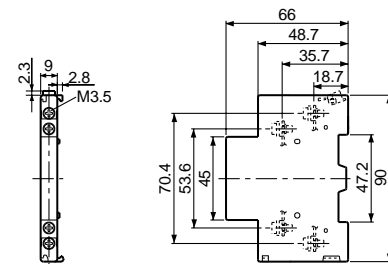

• Alarm contact blocks, front mounting
BZ0KI

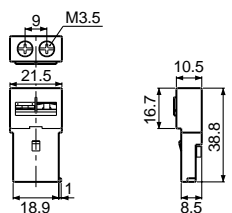

• Auxiliary and alarm contact blocks
BZ0WКУ

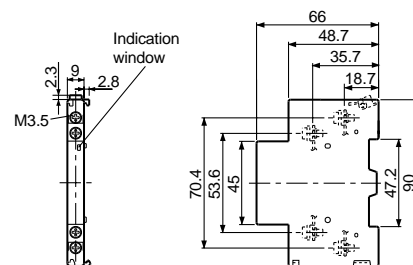

DUO series Manual Motor Starters

Dimensions

■ Dimensions, mm

Accessories

- Short-circuit alarm contact block
BZ0TKUAB

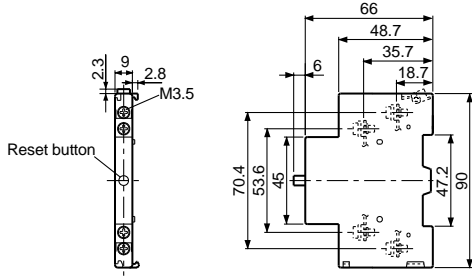

- Shunt trip devices BZ0F
- Undervoltage trip devices BZ0R

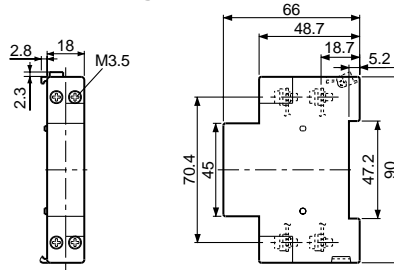

MMS with accessories

- BM3RSB + BZ0
- BM3RSR + BZ0

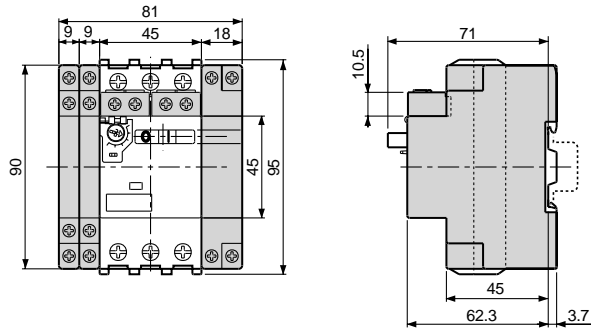

- BM3RSB + BZ0□LKU (Undervoltage trip device)
- BM3RSR + BZ0□LKU

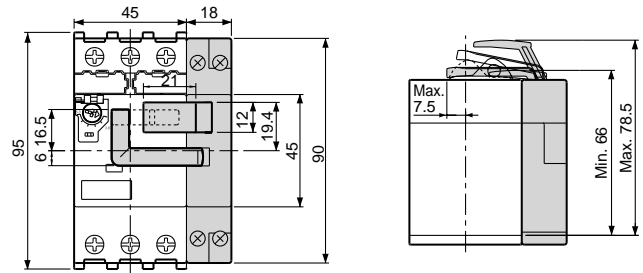

- BM3RHB + BZ0
- BM3RHR + BZ0

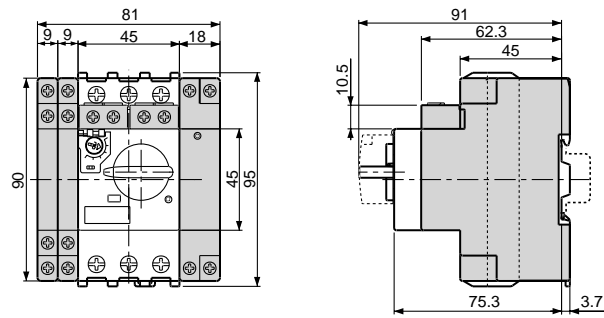

- BM3V□B + BZ0

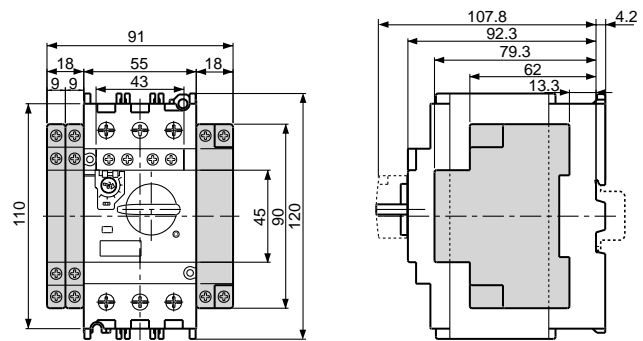

External operation handle BZ0V

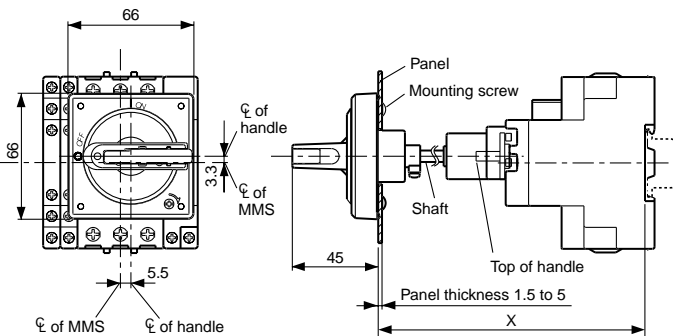

Type	X min.	X max.
BZ0VBBL, BZ0VYRL	139±2	289±2
BZ0VBBL, BZ0VYRM	156±2	306±2

Panel drilling

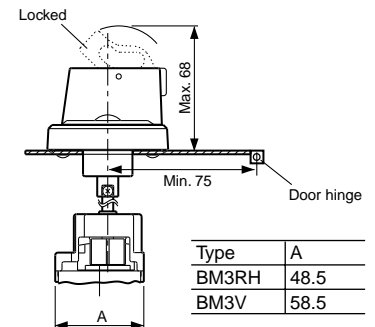
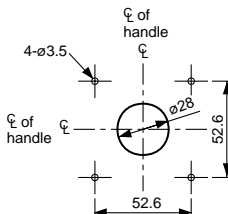

Type	A
BM3RH	48.5
BM3V	58.5

■ Dimensions, mm

• UL508 Type E

MMS + Terminal cover + short-circuit alarm contact block

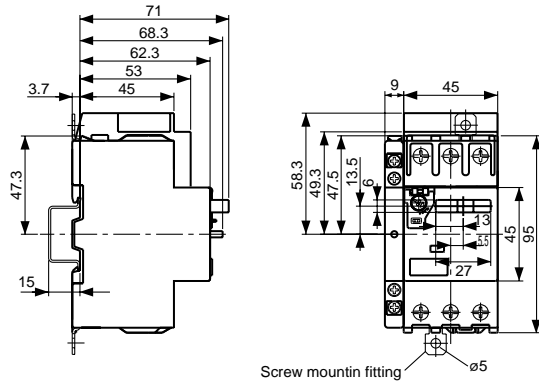

Terminal cover

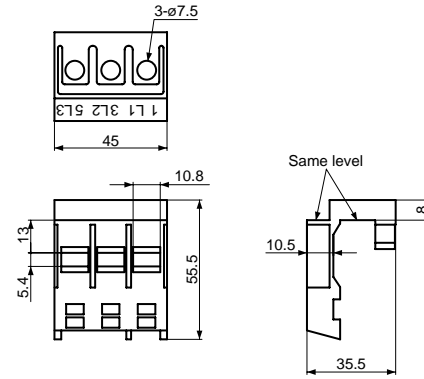

• MMS with long terminal cover

MMS + long terminal cover

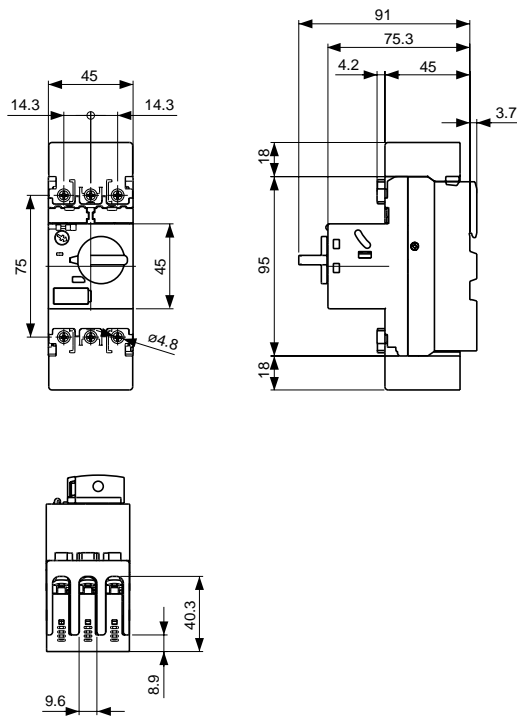

Long terminal cover

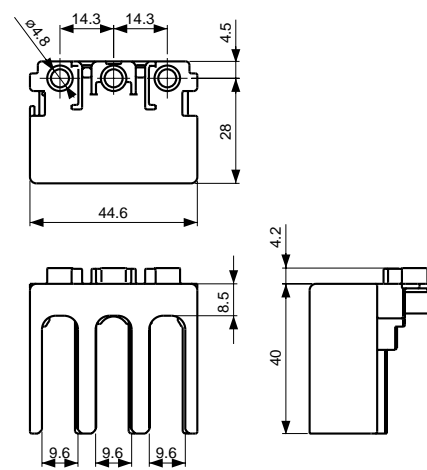

DUO series Manual Motor Starters

Wiring diagrams

■ Wiring diagrams

• MMS

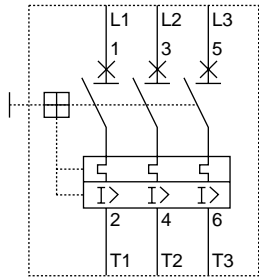

• Auxiliary contact blocks

Front mounting

BZ0WIA

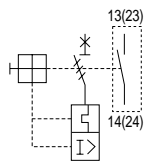

BZ0WIB

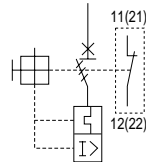

• Alarm contact blocks

Front mounting

BZ0KIA

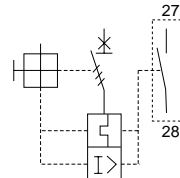

BZ0KIB

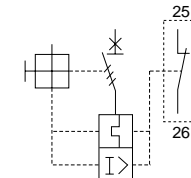

Side mounting

BZ0WUAAL

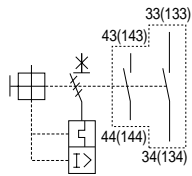

BZ0WUABL

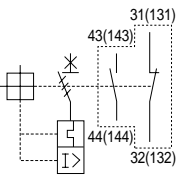

BZ0WUBBL

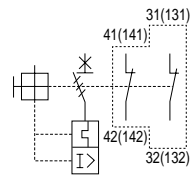

• Auxiliary and alarm contact blocks

BZ0WKUAA

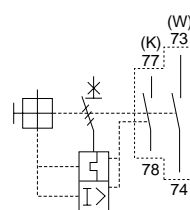

BZ0WKUBA

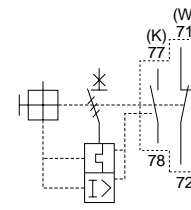

BZ0WUAAR

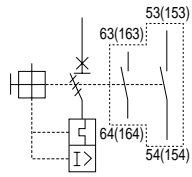

BZ0WUABR

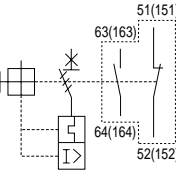

BZ0WUBBR

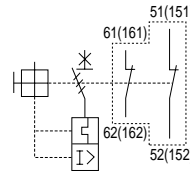

BZ0WKUAB

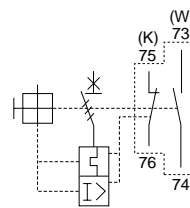

BZ0WKUBB

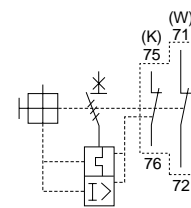

• Short-circuit alarm contact blocks

BZ0TKUAB

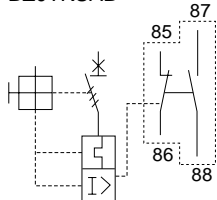

• Shunt trip devices

BZ0F

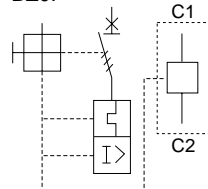

• Undervoltage trip devices

BZ0R

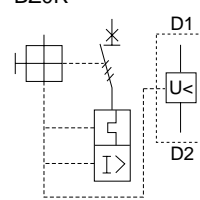

• Undervoltage trip devices with early make contacts

BZ0R

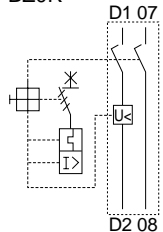

There may be no trip indication and no opening of the auxiliary contact even though the MMS is tripped due to short-circuit, overcurrent, or phase-loss.

External connection

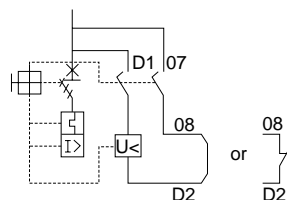

In addition to the functions of the undervoltage trip device, this device completely opens the main circuit and control circuit when the MMS is turned OFF. However, when the MMS is tripped by a drop in the control circuit voltage, it must be reset.

Standard operating conditions

Ambient temperature	Operating: -5 to +55°C Storage: -40 to +65°C	No sudden temperature changes resulting in condensation or icing.
Humidity	45 to 85%RH	
Altitude	2000m or lower	
Atmosphere	No excessive dust, smoke, corrosive gases, flammable gases, steam or salt.	
Vibration	10 to 55Hz 15m/s ²	No abnormal shock or vibration
Shock	50m/s ²	

Mountings

Rail mounting

The MMS can be mounted to a 35mm top hat rail. Secure the rail with screws at mounting pitch of less than 400mm for the BM3R type and less than 300mm for the BM3V type.

Applicable rail:

Use a 15mm-high TH35-15 rail conforming to EN-50022 and IEC715.

The standard rail mounting direction is horizontal. When using the MMS on a vertically mounted rail, use FUJI end clamp kits.

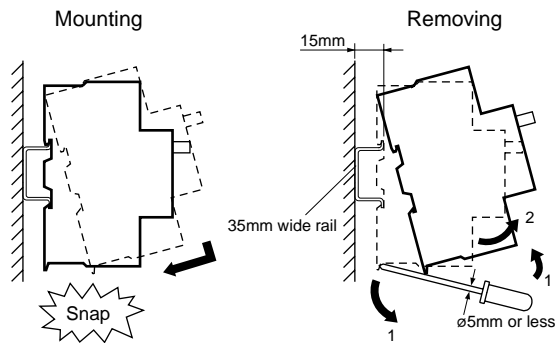

Screw mounting

The separately sold push-in lug (BZ0SET) is required for screw mounting the BM3R frame. The BM3V frame can be screw mounted directly to the panel.

BM3RSB, RSBK
BM3RHB, RHBK

BM3VSB, VSBK
BM3VHB, VHBK

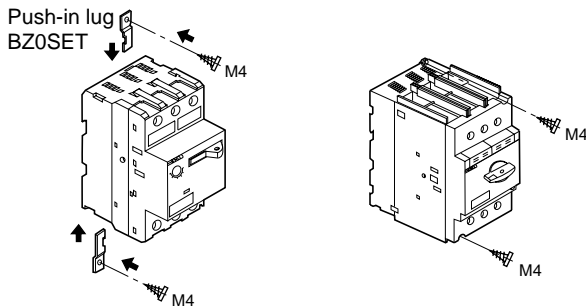

Mounting angle

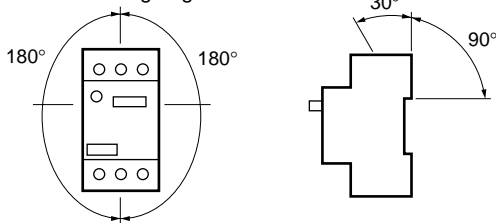

Arc space

The arc space required when mounting is shown in the table below.

Type	Rated operational voltage U _e (V)	Min. distance to grounded metal (mm)	
		A, B	C, D
BM3RS	Up to 460	15	20
	500	15	30
	Up to 690	40	40
BM3RH	Up to 500	15	30
	Up to 690	40	50
BM3V	Up to 500	15	40
	Up to 690	40	50

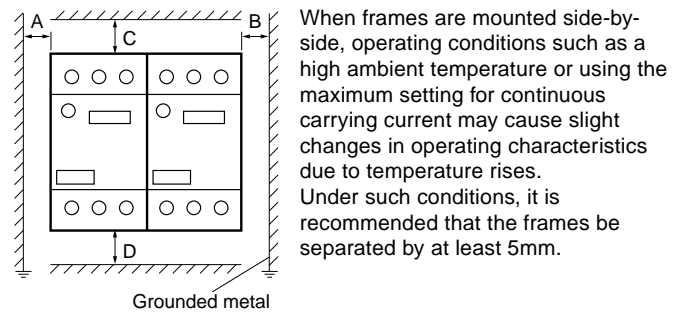

Wirings

While pressing the wire with a screwdriver, tighten the screw to the specified tightening torque.

Type	BM3R	BM3V	BZ0 Accessories
Solid wire (mm)	ø1.6 to 2.6	ø1.6 to 2.6	ø1 to 1.6
Stranded wire (mm ²)	Single-wire	1 to 10	1 to 25
	2-wire	1 to 6	1 to 16
AWG	Single-wire	18 to 8	18 to 4
	2-wire	18 to 10	18 to 4
Sheath stripping length (mm)	Approx.10	Approx.13	Approx.10
Terminal screw	Pan head screw (PZ2)	Pan head screw (PZ2)	Pan head screw (PZ2)
	M4	M6	M3.5
Tightening torque (N·m)	2	4	0.8

Note: There is no need for a crimp terminal or any other terminal on the end of the connection wire.

DUO series Manual Motor Starters

Busbar system

Busbar system

■ Features

- The busbar system reduces wiring time and saves floorspace.
- The busbar makes it easy to power from 2 to 5 manual motor starters – with no wiring needed.
- The 3-phase feed-in terminals are used to connect the wire for the power supply circuit.
- The busbar cover guards against accidental touching of non-connected busbar terminals (charged parts).

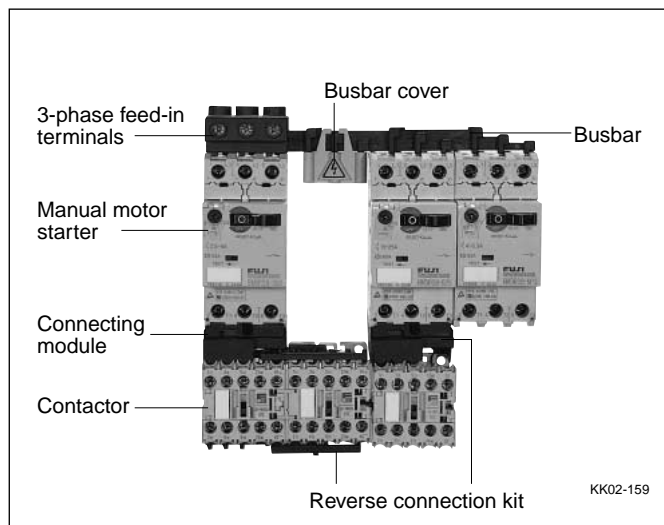

■ Types and ratings

Description	Used with	Specification	Type	Mass (g)	
 KK02-164	BM3R	Continuous current: 64A max. Pin connection *	2-BM3R, modular space: 45mm 3-BM3R, modular space: 45mm 4-BM3R, modular space: 45mm 5-BM3R, modular space: 45mm	BZ0BR02A BZ0BR03A BZ0BR04A BZ0BR05A	30 50 70 90
	BM3R+1-external accessory, 9mm wide		2-BM3R, modular space: 54mm 3-BM3R, modular space: 54mm 4-BM3R, modular space: 54mm 5-BM3R, modular space: 54mm	BZ0BR12A BZ0BR13A BZ0BR14A BZ0BR15A	30 55 80 105
	BM3R+2-external accessory, 9mm wide or BM3R+1-external accessory, 18mm wide	Continuous current: 64A max. Fork connection	2-BM3R, modular space: 63mm 4-BM3R, modular space: 63mm	BZ0BR22A BZ0BR24A	45 100
	BM3V	Continuous current: 126A max. Pin connection	2-BM3V, modular space: 55mm 3-BM3V, modular space: 55mm 4-BM3V, modular space: 55mm	BZ0BV02A BZ0BV03A BZ0BV04A	140 240 340
	BM3V+1-external accessory, 9mm wide		2-BM3V, modular space: 64mm 3-BM3V, modular space: 64mm 4-BM3V, modular space: 64mm	BZ0BV12A BZ0BV13A BZ0BV14A	150 270 380
	BM3V+2-external accessory, 9mm wide or BM3V+1-external accessory, 18mm wide		2-BM3V, modular space: 73mm 4-BM3V, modular space: 73mm	BZ0BV22A BZ0BV24A	165 425
	3-phase feed-in terminal AF01-70R	BM3R	Continuous current: 64A max. Applicable cable size: 25mm ² max.	BZ0BFRA	40
		BM3V	Continuous current: 126A max. Applicable cable size: 50mm ² max.	BZ0BFVA	170
	Busbar cover AF01-70L	BZ0BR	For pin connection For fork connection	BZ0BCRA BZ0BCRB	10 5
		BZ0BV	For pin connection	BZ0BCVA	5

Notes: • When three or more busbar are used, a gap of 6mm will occur between the MMS at the connector point.
* Maximum number of MMS that can be mounted side by side using the two busbar (ex. BZ0BR05A × 2)

■ Dimensions, mm

• For BM3R

BZ0BR0 Without external accessory

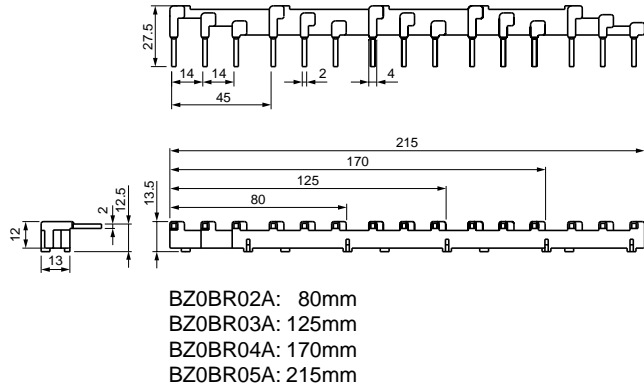

• For BM3V

BZ0BV0 Without external accessory

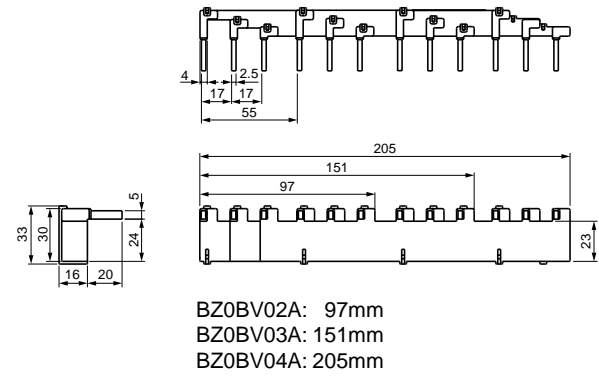

BZ0BR1 With 1-external accessory

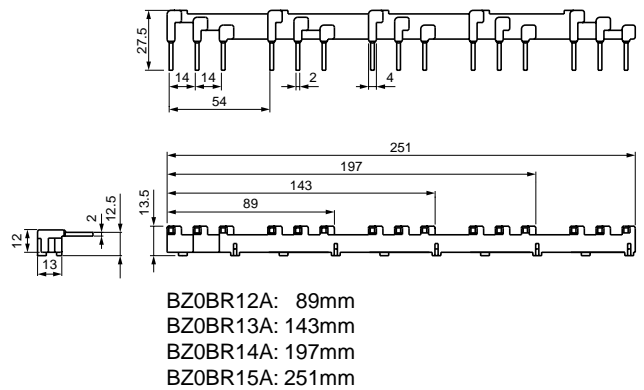

BZ0BV1 With 1-external accessory, 9mm wide

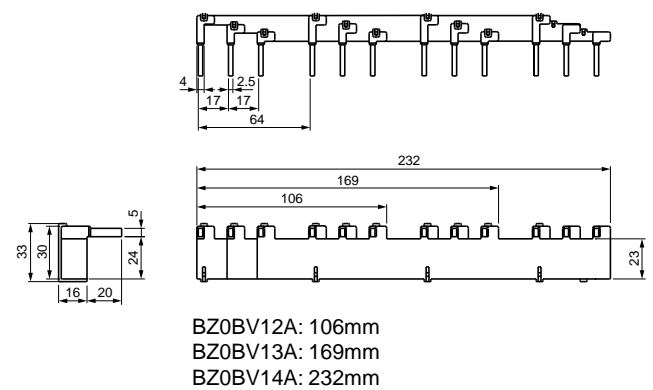

BZ0BR2 With 2-external accessory, 9mm wide
With 1-external accessory, 18mm wide

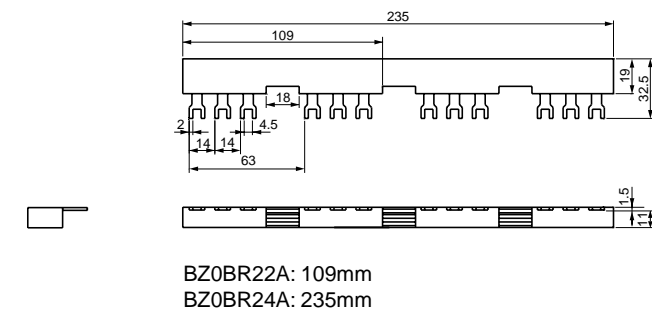

BZ0BV2 With 2-external accessory, 9mm wide
With 1-external accessory, 18mm wide

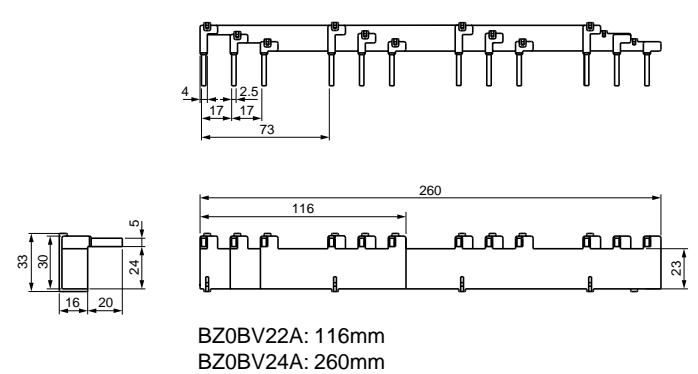

DUO series Manual Motor Starters Busbar system

■ Dimensions, mm
• 3-phase feed-in terminals
BZ0BFRA

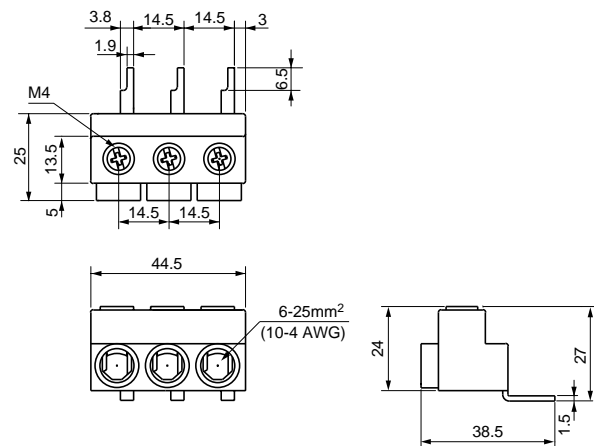

BZ0BFVA

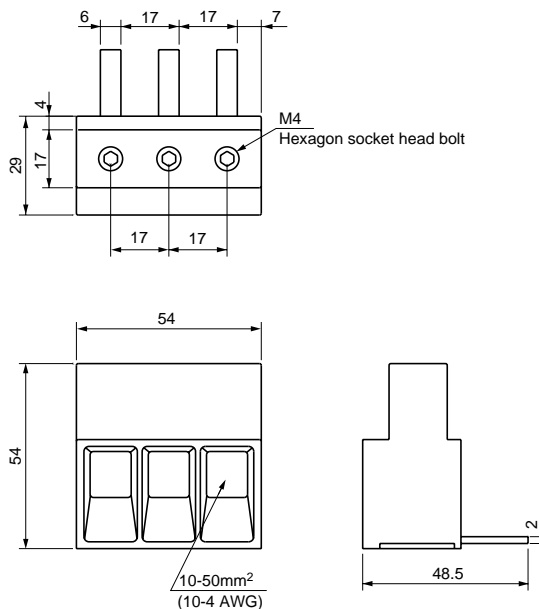

■ Busbar connection

• For BM3R

Example of two pin-connection busbars + 3-phase feed-in terminal

- (1) Insert the busbar 1 in the left side of MMS terminal screw. (2) Insert the busbar 2 in the right side of MMS terminal screw.

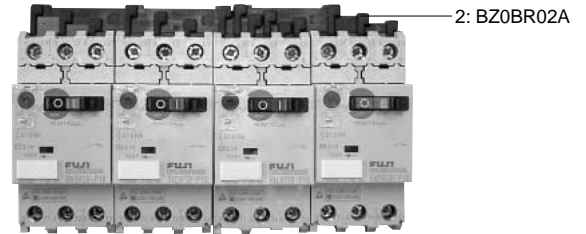

- (3) Attach the 3-phase feed-in terminal (BZ0BFRA) to the MMS from which the busbar has been inserted in the right side of terminal screw. (The mounting position of 3-phase feed-in terminal is same too even if one busbar is to be attached.)



Note: When three or more busbars are used, a gap of 6mm will occur as shown below. Please ask FUJI for details.

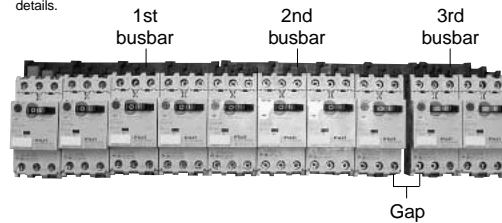

Example of two fork-connection busbars + 3-phase feed-in terminal

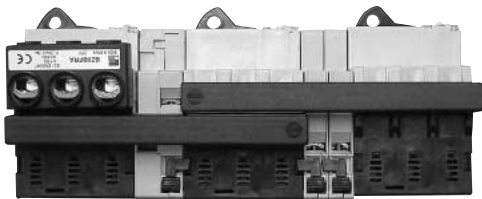

Note: When three or more busbars are to be connected, attach them on MMS, piling up and down as well as two busbars.

• For BM3V

Example of two busbars + 3-phase feed-in terminal

- (1) Insert the busbar 1 in the lower side of MMS terminal plate. (2) Insert the busbar 2 in the upper side of MMS terminal plate.



- (3) Attach the 3-phase feed-in terminal (BZ0BFVA) to the MMS from which the busbar has been inserted in the lower side of terminal plate. (The mounting position of 3-phase feed-in terminal is same too even if one busbar is to be attached.)



Note: When three or more busbars are to be connected, insert 3rd busbar or later up and down of the terminal plate alternately. (The MMSs are capable of side-by-side mounting.)

DUO series Manual Motor Starters Enclosures

Enclosures

■ Features

- Accommodates a variety of manual motor starters (BM3RSB-P16 to 025). Put the manual motor starter inside an enclosure for use in harsh environments. Surface mounting and flush mounting types available.
- IP41 and IP55 enclosure protection degree available
- Manual motor starters (BM3RSB-P16 to 025) equipped with internal accessories and the following external accessories can be used inside an enclosure.
Left side: One auxiliary contact block or one auxiliary/ alarm contact block
Right side: One shunt trip device or one undervoltage trip device
- A wide variety of enclosure accessories are available. Padlocking device, emergency mushroom pushbutton, conversion kit, and indicator lamps

■ Types and ratings

Enclosures for BM3RSB-P16 to 025

Mounting	Specification	Type	Mass (g)
Surface	IP41	BZ0CSLA	320
	IP55 (with conversion kit)	BZ0CSLB	340
Flush	IP41	BZ0CFLA	240
	IP55 (with conversion kit)	BZ0CFLB	260

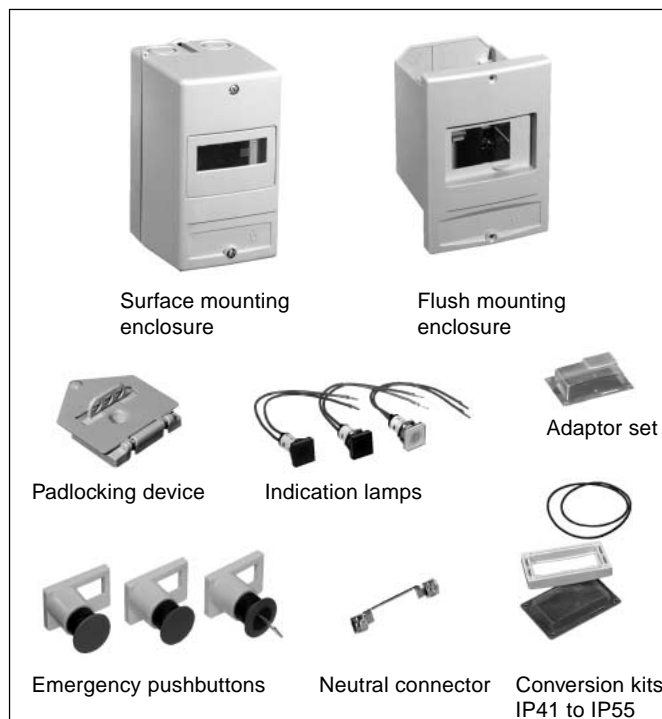

Accessories for enclosures

Description	Specification	Type	Mass (g)
Padlocking device	OFF locking possible using up to three padlocks with a 5 to 8mm shackle diameter.	BZ0CKA	90
Emergency stop pushbutton	Momentary Push-lock turn reset Key operated	BZ0CPM	55
		BZ0CPL	55
		BZ0CPK	90
Conversion kit	Converts IP41 to IP55	BZ0CCA	25
Adaptor set	For BM3RS + undervoltage trip device with auxiliary contact.	BZ0CUA	20
Neutral connector	Used inside the enclosure for neutral and ground connection.	BZ0CNA	10
Indication lamp	Green, 100–120V AC	BZ0CLGA	15
	Green, 200–240V AC	BZ0CLGB	15
	Green, 380–440V AC	BZ0CLGC	15
	Green, 480–500V AC	BZ0CLGD	15
	Green, 500–600V AC	BZ0CLGE	15
	Red, 100–120V AC	BZ0CLRA	15
	Red, 200–240V AC	BZ0CLRB	15
	Red, 380–440V AC	BZ0CLRC	15
	Red, 480–500V AC	BZ0CLRD	15
	Red, 500–600V AC	BZ0CLRE	15
	White, 100–120V AC	BZ0CLCA	15
	White, 200–240V AC	BZ0CLCB	15
	White, 380–440V AC	BZ0CLCC	15
	White, 480–500V AC	BZ0CLCD	15
	White, 500–600V AC	BZ0CLCE	15

Notes: • The padlocking device cannot be used together with the emergency stop pushbutton or undervoltage trip device with early make contact Re.
• The emergency stop pushbutton cannot be used together with the undervoltage trip device with early make contact Re.

■ Dimensions, mm
• Surface mounting
For without accessory

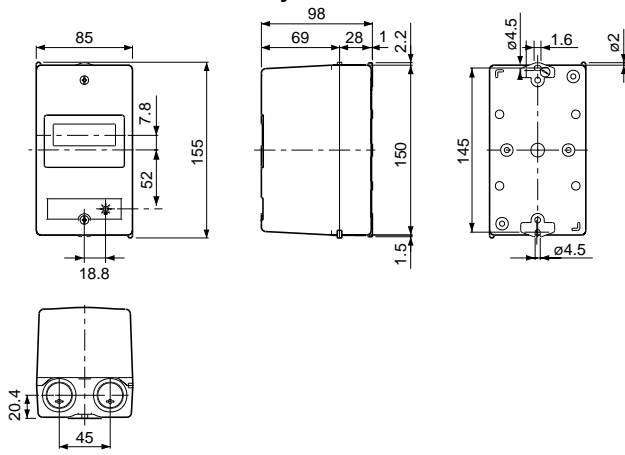

• Flush mounting
For without accessory

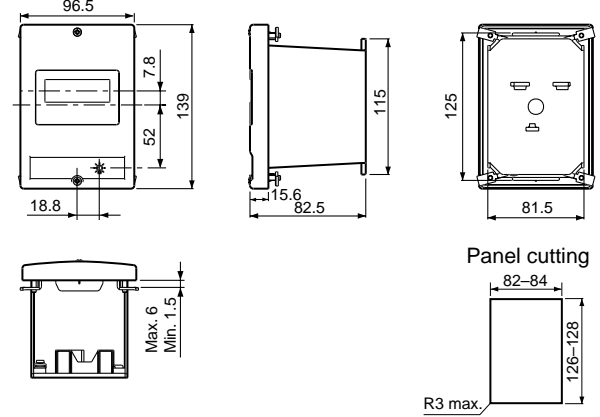

For with padlocking device

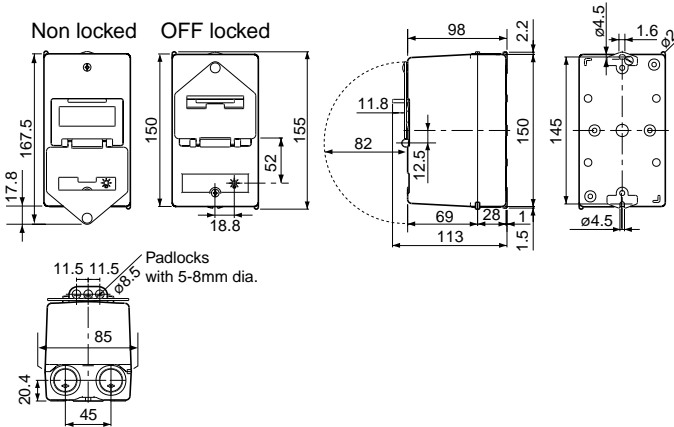

For with padlocking device

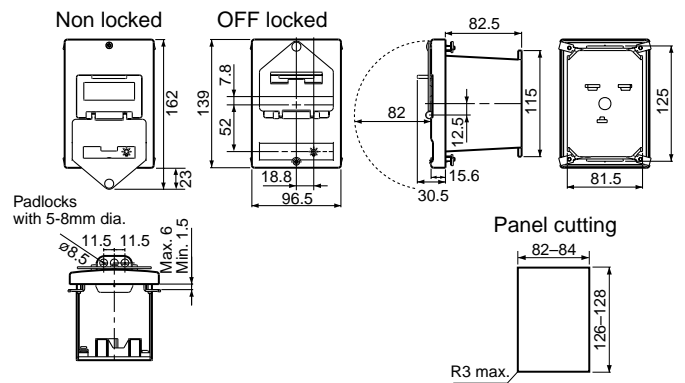

For with emergency pushbutton

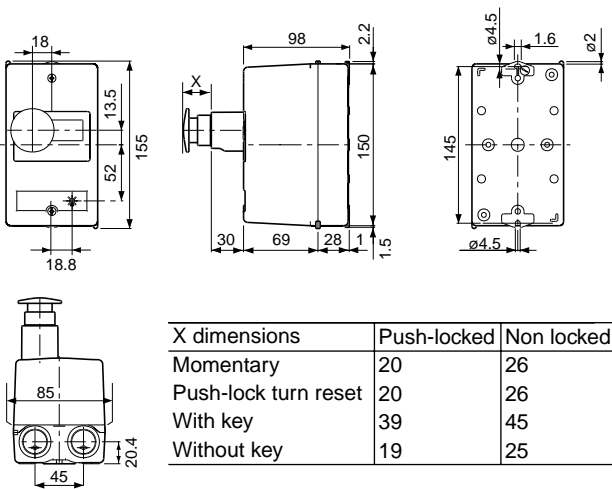

For with emergency pushbutton

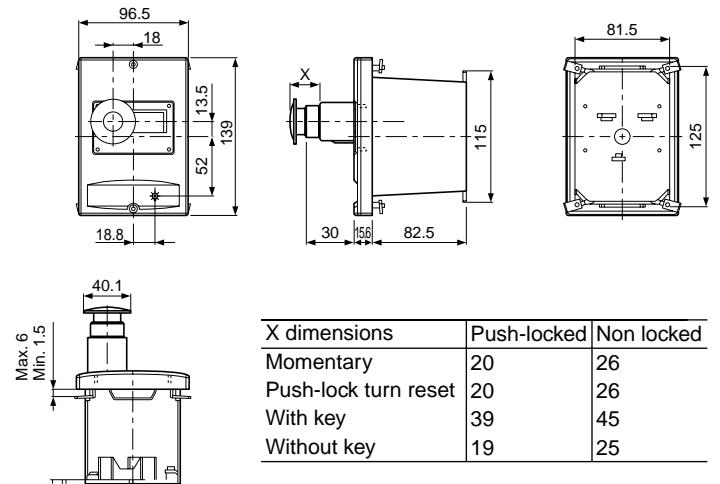

Panel cutting

