



Price* : 128.00 GBP



Main

Range of product	Modicon STB distributed I/O solution
Product or component type	Basic digital output kit
Kit composition	STBDDO3705 module STBXBA3000 base STBXTS2180, 18-terminal spring clamp connector
Discrete output number	16
Discrete output type	Solid state
Discrete output voltage	24 V
Discrete output voltage type	DC

Complementary

Discrete output current	500 mA
Discrete output logic	Positive
Permissible voltage	19.2...30 V DC
Output voltage	19.2...30 V DC
Absolute maximum voltage	35 V 1.3 ms
Response time	2 ms off-to-on 2 ms on-to-off
Cold swapping	Yes
Hot swapping fallback	No for basic NIMs
Protection type	Reverse polarity protection Short-circuit protection Thermal overload protection Power protection integrated fuse on PDM time lag 5 A
Insulation between channels and logic bus	1500 V for 1 minute
Leakage current	≤ 0.4 mA at state 0 30 V
Load capacitance	≤ 10 μ F
Load inductance	≤ 1000 mH 4 Hz
Reset	Manual reset COM fault

Product compatibility	I/O base STBXBA3000 Power distribution module STBPDT3100/3105
[Us] rated supply voltage	24 V DC
Supply	Power distribution module
Current consumption	135 mA 5 V DC logic bus
Marking	CE
Overvoltage category	II
Status LED	1 LED green module status (RDY) 1 LED per channel green channel status (OUT1 to OUT16)
Height	13.9 mm
Depth	70 mm
Width	128.3 mm
Product weight	0.086 kg

Environment

Standards	EN/IEC 61131-2
Product certifications	CSA FM Class 1 Division 2 UL
Pollution degree	2 IEC 60664-1
Operating altitude	<= 2000 m
IP degree of protection	IP20 EN 61131-2 class 1
Ambient air temperature for operation	0...60 °C without
Ambient air temperature for operation	32...140 °F without
Ambient air temperature for storage	-40...85 °C without
Ambient air temperature for storage	-40...185 °F without
Relative humidity	95 % 60 °C without condensation
Vibration resistance	+/-0.35 mm 10...58 Hz 3 gn 58...150 Hz 35 x 7.5 mm symmetrical DIN rail 5 gn 58...150 Hz 35 x 15 mm symmetrical DIN rail
Shock resistance	30 gn 11 ms IEC 88 reference 2-27

Offer Sustainability

Sustainable offer status	Green Premium product
RoHS (date code: YYWW)	Compliant - since 0811 - Schneider Electric declaration of conformity Schneider Electric declaration of conformity
REACH	Reference not containing SVHC above the threshold Reference not containing SVHC above the threshold
Product environmental profile	Available Product environmental
Product end of life instructions	Available End of life manual

Contractual warranty

Warranty period	18 months
-----------------	-----------

Dimensions

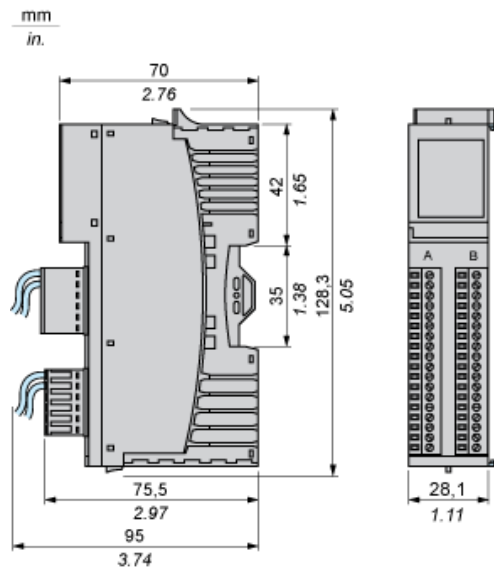

Wiring Diagram

Example

16 two-wire actuators

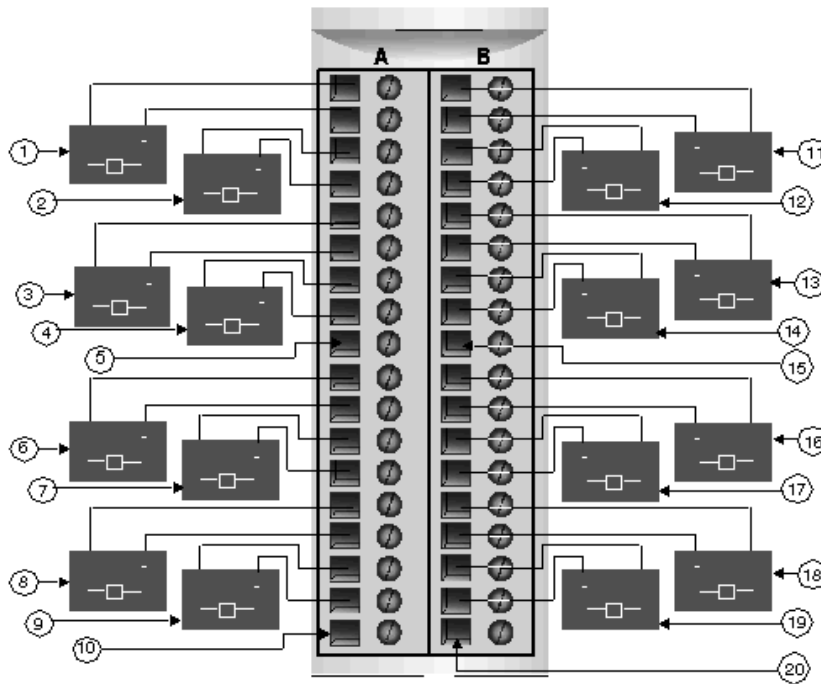

#	Group 1	#	Group 2
1	Channel 1, Connector A, Actuator	11	Channel 1, Connector B, Actuator
2	Channel 2, Connector A, Actuator	12	Channel 2, Connector B, Actuator
3	Channel 3, Connector A, Actuator	13	Channel 3, Connector B, Actuator
4	Channel 4, Connector A, Actuator	14	Channel 4, Connector B, Actuator
5	Pin 9, Connector A (not used)	15	Pin 9, Connector B (not used)
6	Channel 5, Connector A, Actuator	16	Channel 5, Connector B, Actuator
7	Channel 6, Connector A, Actuator	17	Channel 6, Connector B, Actuator
8	Channel 7, Connector A, Actuator	18	Channel 7, Connector B, Actuator
9	Channel 8, Connector A, Actuator	19	Channel 8, Connector B, Actuator
10	Pin 18, Connector A (not used)	20	Pin 18, Connector B (not used)