

LL3-TB01

LL3

FIBERS

SICK
Sensor Intelligence.

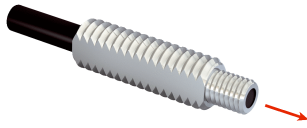

Ordering information

Type	Part no.
LL3-TB01	5308050

Other models and accessories → www.sick.com/LL3

Detailed technical data

Features

Device type	Fibers
Detection principle	Through-beam system
For fiber-optic sensor	GLL170(T), WLL180T, WLL24 Ex
Fiber length	2 m
Fiber material	Polymethylmethacrylat (PMMA)
Jacket material	Polyethylen (PE)
Fiber head material	Stainless steel ¹⁾
Outer diameter, fiber-optic cable connection	2.2 mm
Fiber-optic cable cuttable	✓ ²⁾
Thread size	M4
Fiber-optic head design	Threaded sleeve
Fiber arrangement	Monofiber
Core structure	Ø 1.5 mm Monofiber
Bend radius, fibre-optic cable	30 mm
Angle of dispersion < 60°	No
Compatibility with infrared light (1,450 nm)	No
Ambient operating temperature	-40 °C ... +70 °C
Diameter/thread size from 2 mm taper	≥ 2.6 mm
Length of taper	≥ 3 mm
Highly flexible/elastic fibers (bend radius 1–4 mm)	No
Adapter end sleeves required	No
Angle of dispersion	60°
Integrated lens	No
Minimal object diameter	0.5 mm ³⁾
Special features	Standard, compact end sleeve, large sensing range
Included with delivery	Mounting, 4 x M4 hexagon nut, 4 x washer, FC fiber cutter (5304141)
Compatibility tip adapters	Yes

¹⁾ Stainless steel.

²⁾ FC fiber optic cable cutter included in delivery.

³⁾ Minimum detectable object was determined at optimum measuring distance and optimum setting.

Mechanics/electronics

Bend radius, fibre-optic cable	30 mm
Ambient operating temperature	-40 °C ... +70 °C

Classifications

ECI@ss 5.0	27270905
ECI@ss 5.1.4	27270905
ECI@ss 6.0	27270905
ECI@ss 6.2	27270905
ECI@ss 7.0	27270905
ECI@ss 8.0	27270905
ECI@ss 8.1	27270905
ECI@ss 9.0	27270905
ETIM 5.0	EC002651
ETIM 6.0	EC002651
UNSPSC 16.0901	39121528

Sensing ranges with WLL180T

Operating mode 16 µs	300 mm
Operating mode 70 µs	950 mm
Operating mode 250 µs	1,700 mm
Operating mode 2 ms	3,500 mm
Operating mode 8 ms	4,000 mm

Sensing ranges with GLL170

Operating mode 250 µs	830 mm
------------------------------	--------

Sensing ranges with GLL170T

Operating mode 50 µs	770 mm
Operating mode 250 µs	1,220 mm

Dimensional drawing (Dimensions in mm (inch))

LL3-TB01

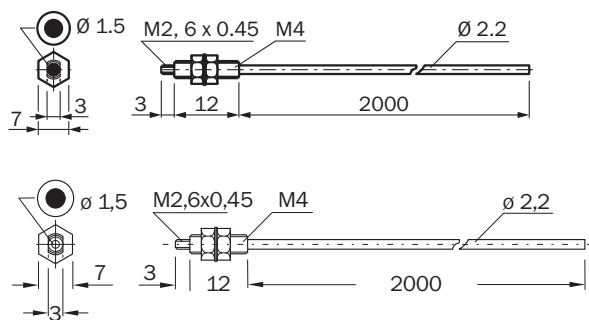

SICK AT A GLANCE

SICK is one of the leading manufacturers of intelligent sensors and sensor solutions for industrial applications. A unique range of products and services creates the perfect basis for controlling processes securely and efficiently, protecting individuals from accidents and preventing damage to the environment.

We have extensive experience in a wide range of industries and understand their processes and requirements. With intelligent sensors, we can deliver exactly what our customers need. In application centers in Europe, Asia and North America, system solutions are tested and optimized in accordance with customer specifications. All this makes us a reliable supplier and development partner.

Comprehensive services complete our offering: SICK LifeTime Services provide support throughout the machine life cycle and ensure safety and productivity.

For us, that is “Sensor Intelligence.”

WORLDWIDE PRESENCE:

Contacts and other locations –www.sick.com