

EExOG 9

Ex approval ATEX II 2 G Ex db eb IIC T5/T6 Gb and IECEx Ex db eb IIC T5/T6 Gb
 120...5000 pulses per revolution

Overview

- Encoder incremental / ATEX / IECEx
- Optical sensing method
- ATEX II 2 G Ex db eb IIC T5/T6 Gb
- IECEx Ex db eb IIC T5/T6 Gb
- Robust light-metal housing
- Output stage HTL or TTL
- Output stage TTL with regulator UB 9...26 VDC
- Large terminal box, turn by 90°
- Optional: Cable gland M20x1.5 or M25x1.5



Technical data

Technical data - electrical ratings

Voltage supply	9...30 VDC 5 VDC ±5 % 9...26 VDC
Consumption w/o load	≤100 mA
Pulses per revolution	120 ... 5000
Phase shift	90 ° ±20°
Duty cycle	40...60 %
Reference signal	Zero pulse, width 90°
Sensing method	Optical
Output frequency	≤120 kHz (pulses ≤1250) ≤250 kHz (pulses >1250)
Output signals	K1, K2, K0 + inverted
Output stages	HTL TTL/RS422
Interference immunity	EN 61000-6-2
Emitted interference	EN 61000-6-3
Approval	CE ATEX IECEx

Technical data - mechanical design

Size (flange)	ø115 mm
Shaft type	ø11 mm solid shaft
Admitted shaft load	≤200 N axial ≤350 N radial

Technical data - mechanical design

Flange	EURO flange B10
Protection EN 60529	IP 56
Operating speed	≤6000 rpm (T5, mechanical) ≤4500 rpm (T6, mechanical)
Operating torque typ.	4 Ncm
Rotor moment of inertia	290 gcm ²
Material	Housing: aluminium die-cast Shaft: stainless steel
Ambient temperature	-20...+55 °C Option: -40...+55 °C (120...2500 pulses per revolution) Option: -25...+55 °C (3072...5000 pulses per revolution)
Resistance	IEC 60068-2-6 Vibration 10 g, 50-2000 Hz IEC 60068-2-27 Shock 100 g, 6 ms
Corrosion protection	IEC 60068-2-52 Salt mist for ambient conditions C4 according to ISO 12944-2
Explosion protection	II 2 G Ex db eb IIC T5/T6 Gb Ex db eb IIC T5/T6 Gb
Connection	Terminal box
Weight approx.	3.5 kg

EExOG 9

Ex approval ATEX II 2 G Ex db eb IIC T5/T6 Gb and IECEx Ex db eb IIC T5/T6 Gb
120...5000 pulses per revolution

Terminal assignment

View A (see dimension)

Connecting terminal terminal box

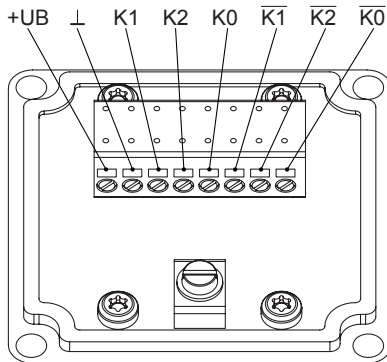

Terminal significance

+UB	Voltage supply
0V (L)	Ground
K1	Output signal channel 1
$\overline{K1}$	Output signal channel 1 inverted
K2	Output signal channel 2 (offset by 90° to channel 1)
$\overline{K2}$	Output signal channel 2 inverted
K0	Zero pulse (reference signal)
$\overline{K0}$	Zero pulse inverted

Output signals

HTL/TTL

At positive rotating direction (see dimension)

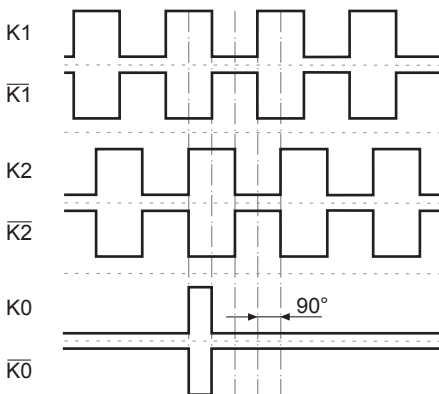

EExOG 9

Ex approval ATEX II 2 G Ex db eb IIC T5/T6 Gb and IECEx Ex db eb IIC T5/T6 Gb
120...5000 pulses per revolution

Dimensions

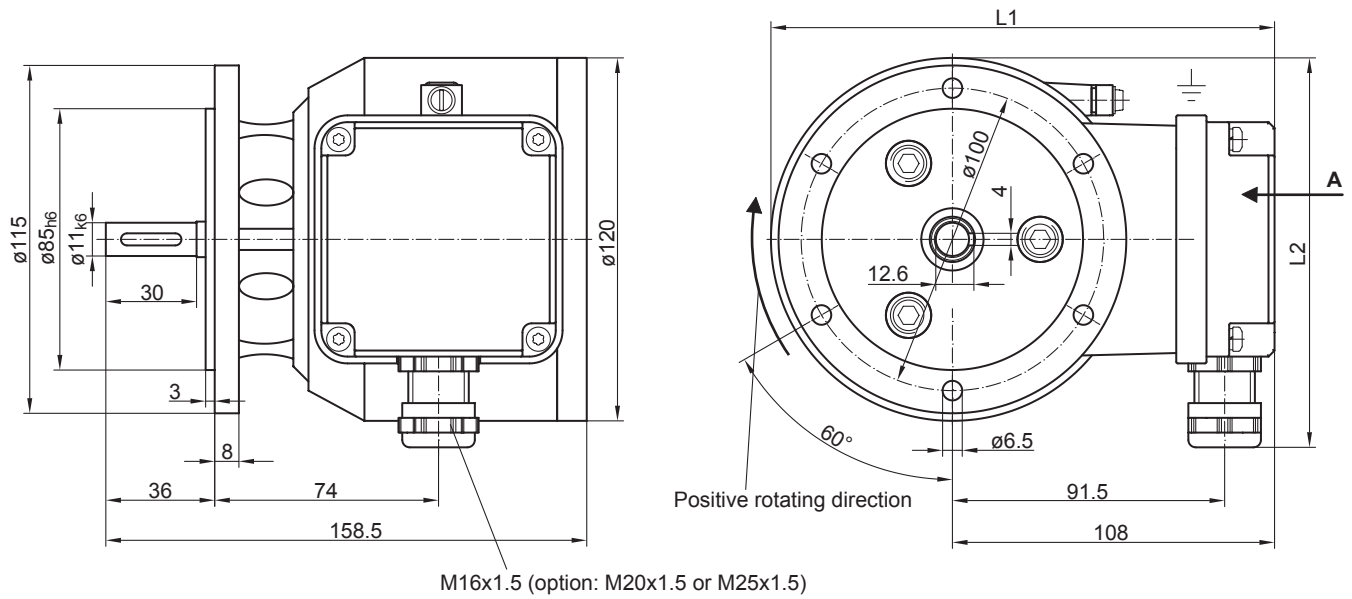

L1	L2	Cable gland
168	~125	M16x1.5
168	~145	M16x1.5 with extension on M20x1.5
168	~129	M20x1.5
177	~129	M25x1.5

EExOG 9

Ex approval ATEX II 2 G Ex db eb IIC T5/T6 Gb and IECEx Ex db eb IIC T5/T6 Gb
 120...5000 pulses per revolution

Ordering reference

	EExOG9	DN	###	###
Product				
Incremental encoder	EExOG9			
Output signals				
K1, K2, K0		DN		
Pulse number				
120				120
128				128
180				180
256				256
360				360
500				500
512				512
1000				1000
1024				1024
1250				1250
2048				2048
2500				2500
3072				3072
3600				3600
4096				4096
5000				5000

Voltage supply / output stage

9...30 VDC / output stage HTL with inverted signals	I
5 VDC / output stage TTL with inverted signals	TTL
9...30 VDC / output stage TTL with inverted signals	R

Accessories

Mounting accessories

- Spring disk coupling K 35 (shaft ø6...12 mm)
- Spring disk coupling K 50 (shaft ø11...16 mm)
- Spring disk coupling K 60 (shaft ø11...22 mm)

Diagnostic accessories

- 11075858 Analyzer for encoders HENQ 1100
- 11075880 Analyzer for encoders HENQ 1100 B