

KombiSIGN 50 / Accessories

Contact box for cable exit at side



Part No.: 975.840.01

MECHANICAL DATA

Height	29 mm
Diameter	70 mm
Materials	PA-GF
Housing colour	Black
Protection category	IP54
Weight with packaging	71 g
Product weight	71 g

DRAWING

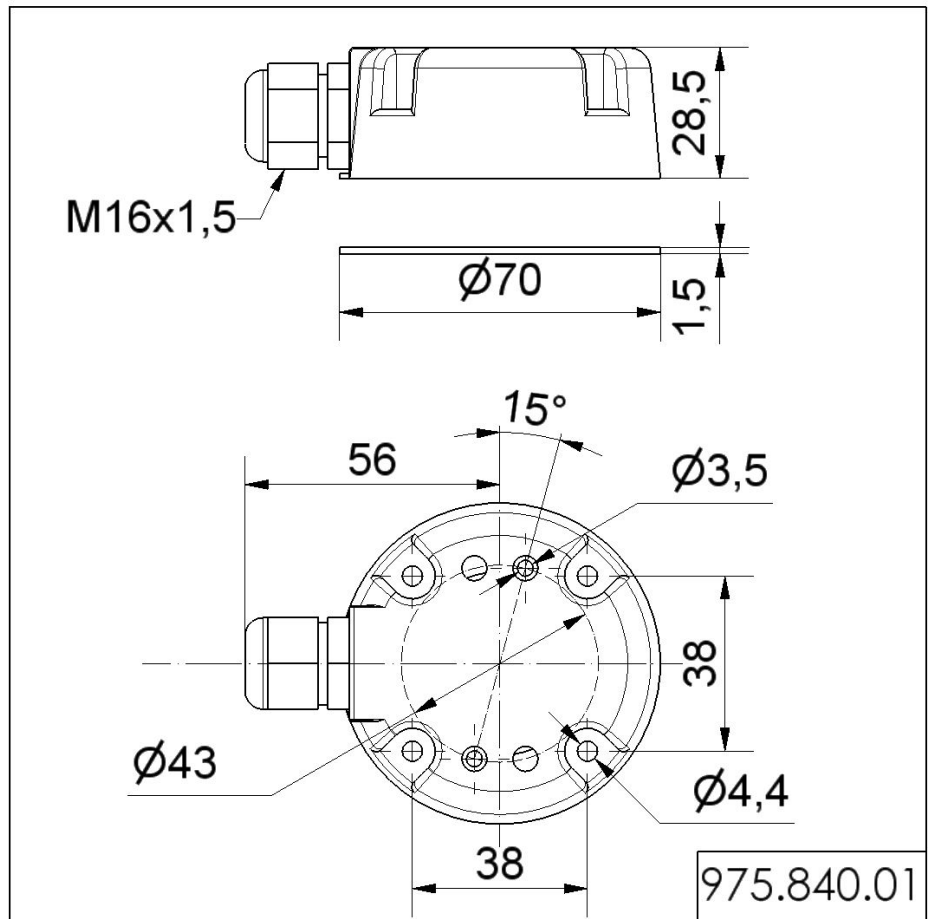

! For additional installation and mounting information, refer to the appropriate user guide at www.werma.com. This printed copy is for information only and is subject to alteration.