

PROTECTION CAPS AND PROTECTION SETS

Protection Caps M30 / M32 PTFE



PROTECTION CAP

The PTFE protection cap (PEEK and Delrin are also available) is designed for applications where the detected material is highly abrasive, e.g. granules. It is a protection cap for the front cap of the sensor. In the case of damage due to abrasion one only has to change the protection cap and the sensor remains in good condition.

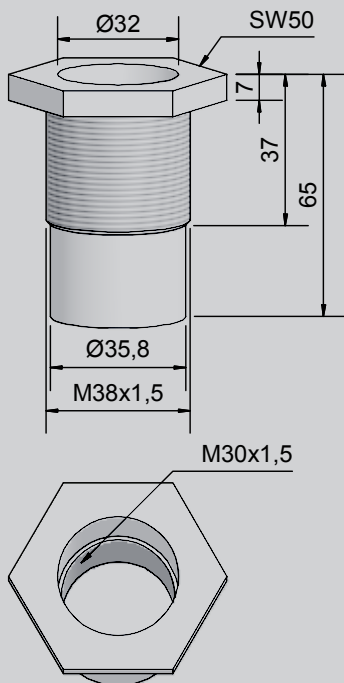

Dimension: Protection Cap M30
 PTFE Art.-No. 190503
 PEEK Art.-No. 190504
 Delrin Art.-No. 190505

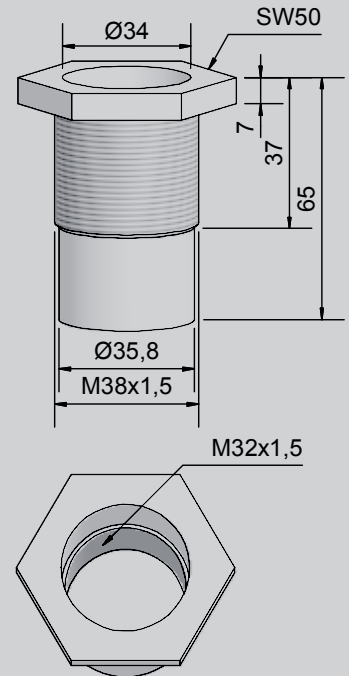

Dimension: Protection Cap M32
 PTFE Art.-No. 190500
 PEEK Art.-No. 190501
 Delrin Art.-No. 190502

Protection Set M32



PROTECTION SET

The PTFE protection set M 32 x 1.5 consists of an internally threaded cover, a Pg9-screwing for cable entry and a rubber gasket between the cover and the sensor. This protection cover serves as improvement to the degree of protection, against infiltration of liquids, for example in applications where the sensor is totally immersed in liquids. The resistance of the material still needs to be checked.

The thread of the sensor has to be sealed, for example with PTFE sealing-tape. The protection cover has to be screwed totally up to the end, and then the Pg-screw has to be fixed.

Protection Set M18 Art.-No. 196305
 Protection Set M30 Art.-No. 196302
 Protection Set M32 Art.-No. 196301