



LV capacitor CLMD

Reliability for power factor correction

Reliability for power factor correction

CLMD construction

- The CLMD capacitor consists of a number of wound elements made with a dielectric of metallized polypropylene film. These dry windings are provided with a sequential disconnecter ensuring that each element can be reliably and selectively disconnected from the circuit at the end of its life
- The capacitor elements receive a treatment under vacuum in order to ensure perfect electrical characteristics. Each winding is placed in a plastic case and encapsulated in thermo-setting resin in order to obtain a perfectly sealed element
- The elements are placed inside a sheet steel box and connected in such a way as to supply the single or three-phase power at the required voltage and frequency

- The sheet steel box is filled with inorganic, inert and fire proof granules in order to absorb the energy produced or to extinguish any flames in case of a possible defect at the end of an element's life. The CLMD is also provided with thermal equalizers to ensure effective heat dissipation

High performance in-house metallized film

ABB's completely integrated manufacturing process has resulted in the development of the special ABB high-performance film of which all ABB LV capacitors benefit:

- high breakdown strength
- excellent peak current handling capability
- high capacitance stability
- optimal self healing design
- long life

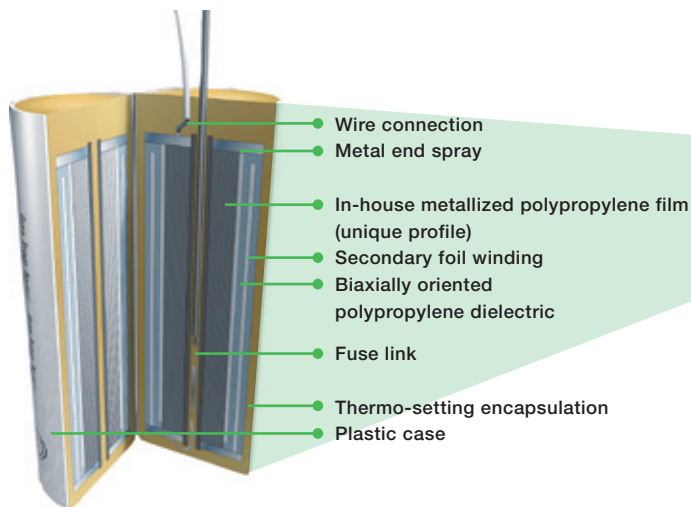

Capacitor element

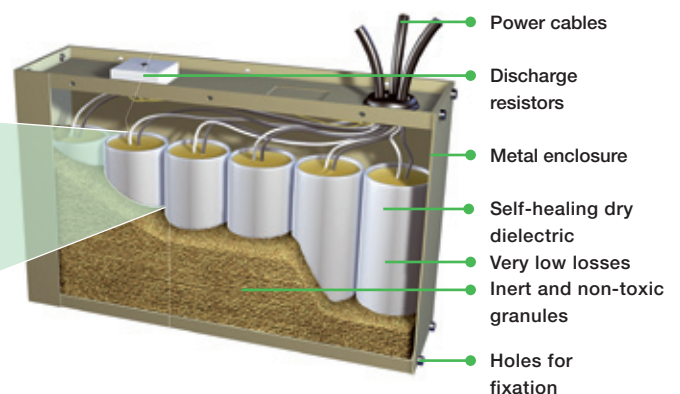

CLMD 33S

Reliable and safe

Dry type design

The CLMD has a dry type dielectric and therefore cannot give any risk of leakage or pollution of the environment.

Very low losses

Dielectric losses are less than 0.2 Watt per kvar. Total losses, including discharge resistors, are less than 0.5 Watt per kvar.

Long life – self-healing

In the event of a fault developing in the dielectric of the capacitor, the metallized electrode adjacent to the fault is immediately vaporized, thus insulating the fault. The capacitor then continues normal operation.

Fire protection

All capacitor elements within the CLMD capacitor are surrounded by vermiculite which is an inorganic, inert, fire proof and non toxic granular material. In the event of any failure the vermiculite absorbs safely the energy produced within the capacitor box and extinguishes any possible flames.

Unique protection system

A unique Sequential Protection System ensures that each individual element can be disconnected from the circuit at the end of its life.

Easy to install – light weight

The CLMD capacitor is very lightweight and therefore presents no handling difficulties during installation.

High reliability

The CLMD capacitor complies with the requirements of IEC 60831-1&2. The use of robust terminals removes the risk of damage during installation and reduces maintenance requirements.

Security

Thermal equalizers are fitted to surround each capacitor element and provide effective heat dissipation. The CLMD capacitor is equipped with discharge resistors.

ISO 9001

Our ISO 9001 Quality System registration provides the strongest assurance of our product quality.

ISO 14001

The CLMD capacitor has a dry type dielectric and is free from liquids or other impregnating agents. It has been designed for environmentally friendly manufacturing. Our ISO 14001 certification guarantees our commitment to the environment.

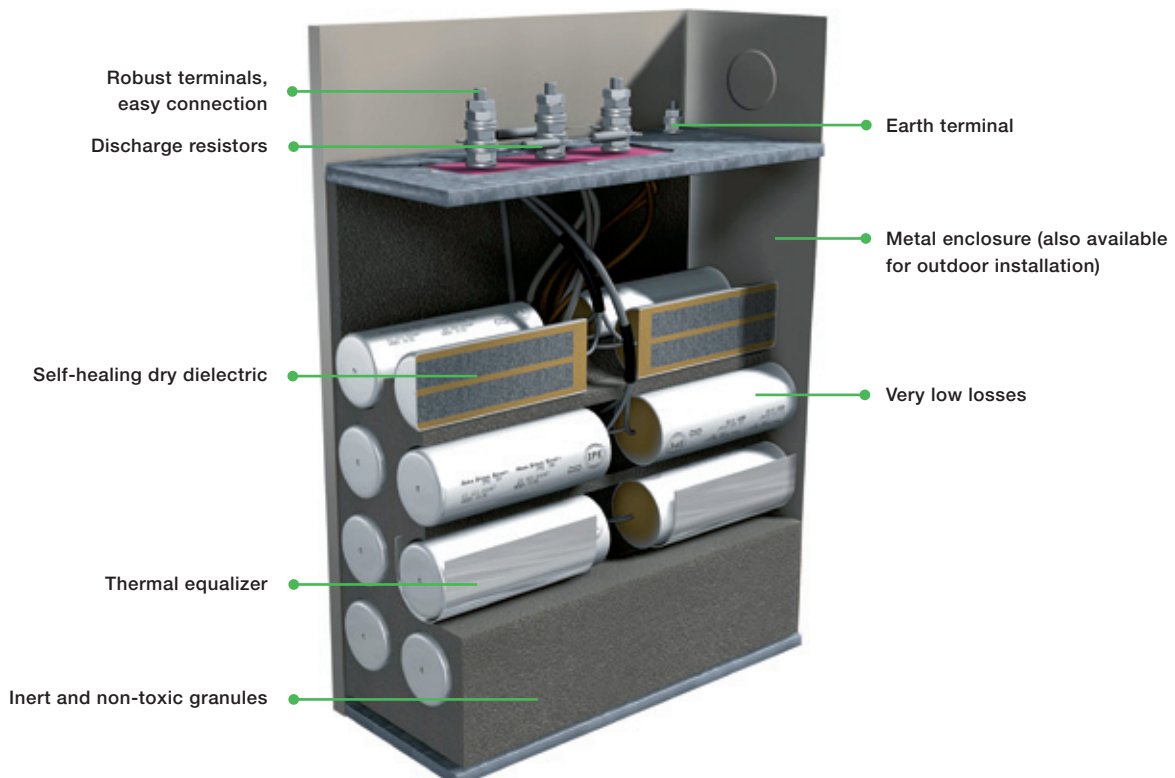

A comprehensive range

CLMD 14, 43, 53, 63 & 83

The CLMD capacitor unit is designed in such a way to give the highest level of reliability, safety, performance and power all in a robust and compact fashion.



Compact – CLMD 33S

The CLMD 33S is intended for use in capacitor banks. It offers high power density and small dimensions.



Technical specifications

Voltage range	From 220 to 1000 V.
Frequency	50 and 60 Hz.
Connection	Three-phase as standard construction (single-phase on request).
Discharge resistors	Permanently connected built-in discharge resistors are sized to ensure safe discharge of the capacitor to less than 50 V in 1 minute after a switch off. Minimum time between disconnection and re-energization: 40 seconds.
Terminals	CLMD14: three M6 terminals. CLMD33S: three cable outputs (6, 10, 16 mm ²), 50 cm long. CLMD43-53-63-83: with threaded rods M6, 8, 10 or 12 according to the power of the capacitor.
Earth	CLMD14-33S: earth connection on the enclosure fixation. CLMD43-53-63-83: a M8 terminal is included.
Cable input	CLMD14: 22.5 mm. 25 mm hole provided. CLMD33S: 500 mm. CLMD43-53: 37 mm. Hole provided. CLMD63-83: 47 mm. Hole provided.
Case material	Zinc electroplated mild steel.
Color	Beige RAL 7032.
Fixing	CLMD14: with two sets of base brackets, drilled 6.0 mm holes. CLMD33S: with eight fixation holes, diameter 5.4 mm. CLMD43-53-63-83: with two slots 26 X 12 mm.
Execution	Indoor (outdoor on request).
Protection	CLMD14-43-53-63-83: IP 42 (IP 54 on request for CLMD43-55, 63 and 83). CLMD33S: IP40.
Maximum ambient temperature	Class „D“ (+55°C) according to IEC 60831.
Minimum ambient temperature	Indoor type: -25°C. Outdoor type: -40°C.
Minimum distance between units	CLMD14-33S: 20 mm (25 mm for units > 30 kvar). CLMD43-53-63-83: 50 mm.
Minimum distance between units and wall	CLMD14-33 : 20 mm (25 mm for units > 30 kvar). CLMD43-53-63-83: 50 mm.
Losses (discharge resistors included)	< 0.5 Watt/kvar for 380 V rated voltage and above.
Tolerance on capacitance	0% + 10%.
Voltage test	Between terminals: 2.15 Un for 10 seconds. Between terminals and earth: 3 kV for 10 seconds for UN < 500 V and 4 kV for 10 seconds for UN > 500 V.
Lightning impulse voltage test	CLMD14-43-53-63-83: 15 kV. CLMD33S: 8 kV.
The acceptable overloads are those specified in IEC 60831-1&2	Overvoltage tolerance: 10% max. at intervals. Overcurrent tolerance: 30% permanently. Maximum overload: stable operation at 135% of the nominal rating (generated by overvoltages and harmonics).

Important: the installation of capacitors on networks disturbed by harmonics may require special precautions, especially when there is a risk of resonance.

Dimensions

CLMD 14

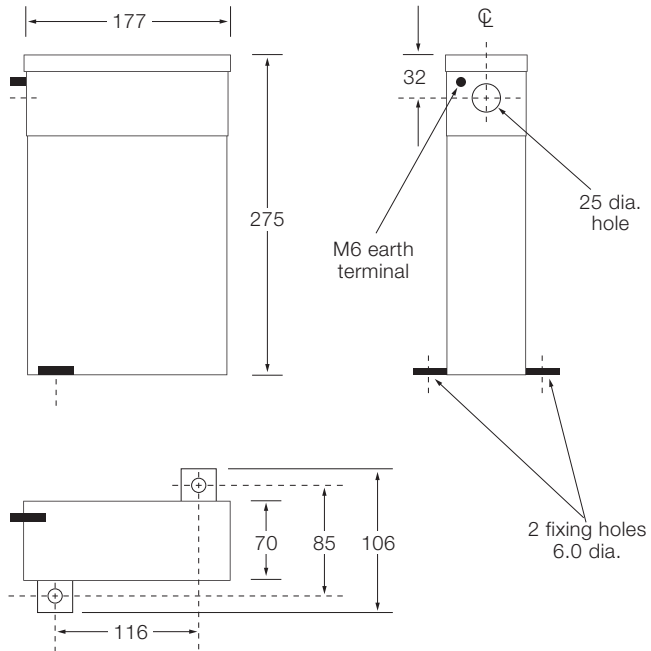

CLMD 33S

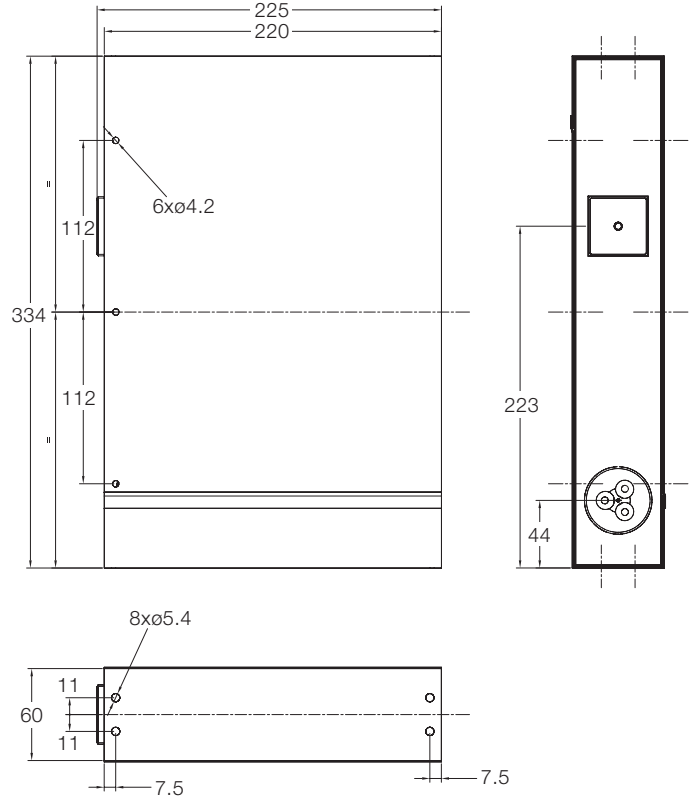

CLMD 43, 53, 63 & 83

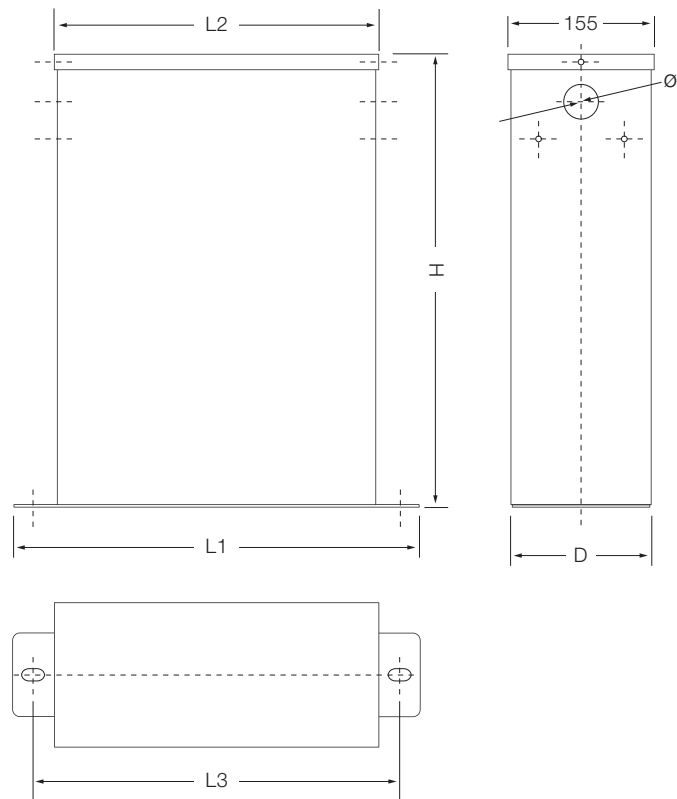

Type	H (mm)	L1 (mm)	L2 (mm)	L3 (mm)	D	Ø (mm)
CLMD43	275	266	180	226	152	37
CLMD53	310	436	350	396	152	37
CLMD63	485	436	350	396	152	47
CLMD83	670	436	350	396	152	47

Range – 50 Hz

CLMD 14, 43, 53, 63 & 83

Network voltage	Type	Power (kvar)		Article number for ordering
		400 V	415 V	
400 V/415 V	CLMD 14	0.83	0.9	PCLMDD1401
	CLMD 14	1.3	1.4	PCLMDD1402
	CLMD 14	1.8	2.0	PCLMDD1403
	CLMD 14	2.5	2.7	PCLMDD1404
	CLMD 14	3.9	4.2	PCLMDD1405
	CLMD 14	5	5.5	PCLMDD1406
	CLMD 14	5.7	6.2	PCLMDD1407
	CLMD 14	8	8.5	PCLMDD1408
	CLMD 14	9.3	10.5	PCLMDD1412
	CLMD 14	10	11.0	PCLMDD1409
	CLMD 14	12	12.5	PCLMDD1410
	CLMD 14	15	16.3	PCLMDD1411
	CLMD 43	15	16	PCLMD55506
	CLMD 43	19.5	21	PCLMDD0012
	CLMD 43	20	22	PCLMD58416
	CLMD 43	23	25	PCLMDD0004
	CLMD 43	25	27	PCLMD55516
	CLMD 53	28	30	PCLMDD0005
	CLMD 53	30	32	PCLMD51036
	CLMD 53	35	37.5	PCLMD50046
CLMD 53	40	43	PCLMD51516	
CLMD 53	45	50	PCLMD50026	
CLMD 63	50	54	PCLMD56916	
CLMD 63	60	65	PCLMD52316	
CLMD 63	70	75	PCLMD50016	
CLMD 63	80	86	PCLMD50106	
CLMD 83	84	90	PCLMDD0006	
CLMD 83	93	100	PCLMDD0007	
CLMD 83	100	110	PCLMD58816	
CLMD 83	120	130	PCLMD50816	

CLMD33S

Network voltage	Associated reactor (%) ⁽¹⁾	Power (kvar) ⁽²⁾		Article number for ordering
		400 V	415 V	
400 V	–	5.0		2GCA289067A0030
	–	10.0		2GCA289068A0030
	–	12.5		2GCA289069A0030
	–	15.0		2GCA289070A0030
	–	20.0		2GCA289071A0030
	–	25.0		2GCA289072A0030
	5.67	12.5		2GCA289078A0030
	5.67	25.0		2GCA289079A0030
	7.0	12.5		2GCA289078A0030
	7.0	25.0		2GCA289079A0030
	–	10.0		2GCA289073A0030
	–	12.5		2GCA289074A0030
–	15.0		2GCA289075A0030	
–	20.0		2GCA289076A0030	
–	25.0		2GCA289077A0030	
5.67	12.5		2GCA289080A0030	
5.67	25.0		2GCA289084A0030	
7.0	12.5		2GCA289080A0030	
7.0	25.0		2GCA289081A0030	

The above ratings are from our standard range of CLMD's.

⁽¹⁾ Associated reactor (%): value of the detuned reactor to be combined with the capacitor unit. Reactors are not provided.

⁽²⁾ Power (kvar): net reactive power output in combination with the associated reactor.

Please consult us for other ratings, single phase units, outdoor executions.

Contact us

ABB Limited
Power Products Division
Rossmore Road East
Ellesmere Port, Cheshire
CH65 3DD, UK

Phone: +44 (0)151 357 8400
Fax: +44 (0)151 355 9137
E-mail: abbep@gb.abb.com

www.abb.com

While all care has been taken to ensure that the information contained in this publication is correct, no responsibility can be accepted for any inaccuracy. We reserve the right to alter or modify the information contained herein at any time in the light of technical or other developments. Technical specifications are valid under normal operating conditions only. We do not accept any responsibility for any misuse of the product and cannot be held liable for indirect or consequential damages.

© Copyright 2011 - ABB Limited