

Operating Instructions

IP4004, Rev. AA

May 2006

Level

PLS Series

Rotary Paddle Level Switch

Standard Model



mobrey

www.mobrey.com

EMERSON
Process Management

Copyright © 2004 - 2006

Mobrey Measurement Ltd.
All Rights Reserved

Mobrey Measurement pursues a policy of continuous development and product improvement. The specification in this document may therefore be changed without notice.

To the best of our knowledge, the information contained in this document is accurate and Mobrey Measurement cannot be held responsible for any errors, omissions or other misinformation contained herein. No part of this document may be photocopied or reproduced without the prior written consent of Mobrey Measurement.

Contents

1	Introduction	4
1.1	Unpacking	4
1.2	Model identification.....	4
2	Pre-installation considerations	5
2.1	Choosing a Location.....	5
2.2	Protective Baffles.....	5
2.3	Paddle Level Switch Preparation.....	6
3	Mechanical Installation	8
3.1	Side Mount /Top Mount	8
3.2	Extension/Guard Installation.....	8
3.3	High-Temp Models	9
3.4	Electrical Connections.....	10
4	Set-up.....	11
4.1	Paddle Selection.....	11
4.2	Sensitivity Spring.....	12
5	Troubleshooting	13
6	Maintenance.....	14
6.1	Motor Replacement	14
6.2	Switch Replacement or Addition.....	14
7	Mechanicals	15
8	Safety	16
9	Specification	17
10	Warranty.....	17

1 Introduction

The Series PLS paddle switch is designed to detect high or low **levels** of free-flowing **dry solids**, such as powders and granules. It is mounted through the wall of a vessel such that the paddle protrudes inside the vessel.

A small electric motor drives a paddle that rotates freely in the absence of material, but is impeded when material is present. When the paddle is impeded, a **micro-switch output** activates to signal an alarm.

To extend the motor life, power is cut to the motor whenever the paddle is free of material. Upon contact with material, the power is restored to the motor once again, therefore rotating the paddle.

Features:

- Time proven.
- Simple and reliable
- Top or side mounting

Applications:

- Aggregates, granular, pelletised or powdered dry products.
- Dry products.
- High, intermediate or low level alarm.

1.1 Unpacking

When unpacking, you should find:

- The Standard Model of the Rotary Paddle Level Switch.
- This Instruction manual (IP4004)
- Safety manual (IP4004/SI) (ATEX version ONLY)

If items are missing from the box, contact the Customer Service Team at Mobrey Measurement to report the missing items and they will then advise you appropriately.

1.2 Model identification

Code	Product										
PLS	Paddle Level Switch series.										
	<table border="1"> <thead> <tr> <th>Code</th> <th>Model</th> </tr> </thead> <tbody> <tr> <td>K</td> <td>Standard model: 2 x SPDT alarm relays.</td> </tr> <tr> <td>H</td> <td>High temperature standard model, 2 x SPDT alarm relays.</td> </tr> <tr> <td>P</td> <td>Failsafe Safepoint model with fault relay and 1 x SPDT alarm relay *</td> </tr> <tr> <td>T</td> <td>High temperature failsafe model with fault relay and 1 x SPDT alarm relay *</td> </tr> </tbody> </table>	Code	Model	K	Standard model: 2 x SPDT alarm relays.	H	High temperature standard model, 2 x SPDT alarm relays.	P	Failsafe Safepoint model with fault relay and 1 x SPDT alarm relay *	T	High temperature failsafe model with fault relay and 1 x SPDT alarm relay *
Code	Model										
K	Standard model: 2 x SPDT alarm relays.										
H	High temperature standard model, 2 x SPDT alarm relays.										
P	Failsafe Safepoint model with fault relay and 1 x SPDT alarm relay *										
T	High temperature failsafe model with fault relay and 1 x SPDT alarm relay *										
	<table border="1"> <thead> <tr> <th>Code</th> <th>Mounting</th> </tr> </thead> <tbody> <tr> <td>B1</td> <td>R 1 ½" BSPT mounting (except high temperature).</td> </tr> <tr> <td>N1</td> <td>1 ¼" NPT mounting (all models).</td> </tr> </tbody> </table>	Code	Mounting	B1	R 1 ½" BSPT mounting (except high temperature).	N1	1 ¼" NPT mounting (all models).				
Code	Mounting										
B1	R 1 ½" BSPT mounting (except high temperature).										
N1	1 ¼" NPT mounting (all models).										
	<table border="1"> <thead> <tr> <th>Code</th> <th>Housing</th> </tr> </thead> <tbody> <tr> <td>3</td> <td>Aluminium alloy housing.</td> </tr> </tbody> </table>	Code	Housing	3	Aluminium alloy housing.						
Code	Housing										
3	Aluminium alloy housing.										
	<table border="1"> <thead> <tr> <th>Code</th> <th>Voltage</th> </tr> </thead> <tbody> <tr> <td>0</td> <td>115V ac motor voltage.</td> </tr> <tr> <td>1</td> <td>240V ac motor voltage.</td> </tr> <tr> <td>2</td> <td>24V dc motor voltage</td> </tr> </tbody> </table>	Code	Voltage	0	115V ac motor voltage.	1	240V ac motor voltage.	2	24V dc motor voltage		
Code	Voltage										
0	115V ac motor voltage.										
1	240V ac motor voltage.										
2	24V dc motor voltage										
	<table border="1"> <thead> <tr> <th>Code</th> <th>Approvals</th> </tr> </thead> <tbody> <tr> <td>A</td> <td>ATEX Dust approval (pending)</td> </tr> <tr> <td>U</td> <td>US General Electric and Dust approval (pending)</td> </tr> <tr> <td>Z</td> <td>No hazardous area approvals</td> </tr> </tbody> </table>	Code	Approvals	A	ATEX Dust approval (pending)	U	US General Electric and Dust approval (pending)	Z	No hazardous area approvals		
Code	Approvals										
A	ATEX Dust approval (pending)										
U	US General Electric and Dust approval (pending)										
Z	No hazardous area approvals										

PLS	K	B1	3	1	Z
-----	---	----	---	---	---

(Typical Model Code)

* Note: For Safepoint failsafe version, refer to manual IP4005 instead of this manual.

2 Pre-installation considerations

2.1 Choosing a Location

(1) Material Flow

When selecting a location for any rotary paddle level switch, choose a point in the vessel where the paddle will be out of the direct flow of incoming and outgoing material (Figure 1); this is to prevent any mechanical damage that may be caused by the pressure of the flow. This is particularly important for materials with large, lumpy characteristics.

The Paddle Level Switch (PLS) series unit must be positioned at a point where incoming material will reach and cover the paddle in its normal flow, and when receding, will flow away from the paddle in an even manner.

(2) Vibration Concerns

Mount the PLS series unit at a location that is subject to limited vibration, away from vessel vibrators thereby attaining maximum operational life (Figure 1). Consult the factory when questionable conditions exist.

(3) Guard Reinforcement

When using rigid extensions and guards in top-mounted applications, select a location where it is feasible to reinforce the guard to the vessel wall (Figure 1). See “Mechanical Installation” section for further details.

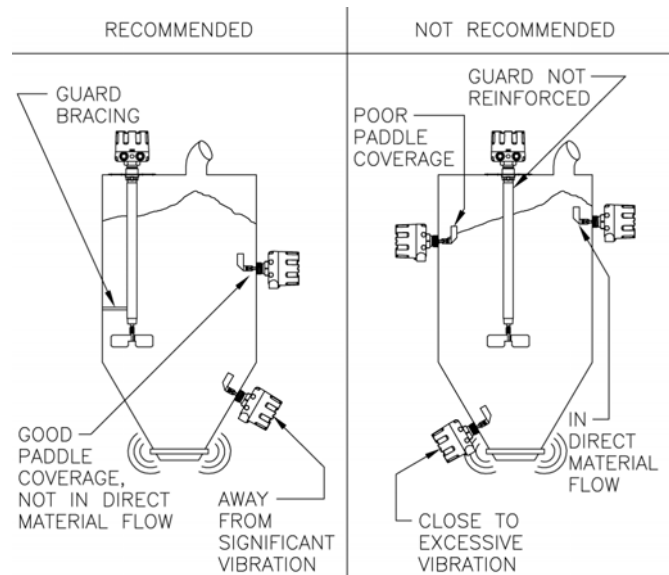

Figure 1

2.2 Protective Baffles

The installation of protective baffles for low-level monitoring is recommended for materials that weigh more than 1050kg/m³ (65 lbs/ft³), have a tendency to pack, bridge, arch, or have unusual flow characteristics.

This baffle can be created using a number of materials including angle iron, welded plates and pipe sections. This structure will keep the full weight of the material from damaging the paddle (Figure 2).

The baffle should be welded to the bin wall and should not extend more than 152 mm (6 inches) into the vessel, as shown in Figure 2. Also, the lowest point of the baffle should be approximately 152 mm (6 inches) above the top of the paddle arc.

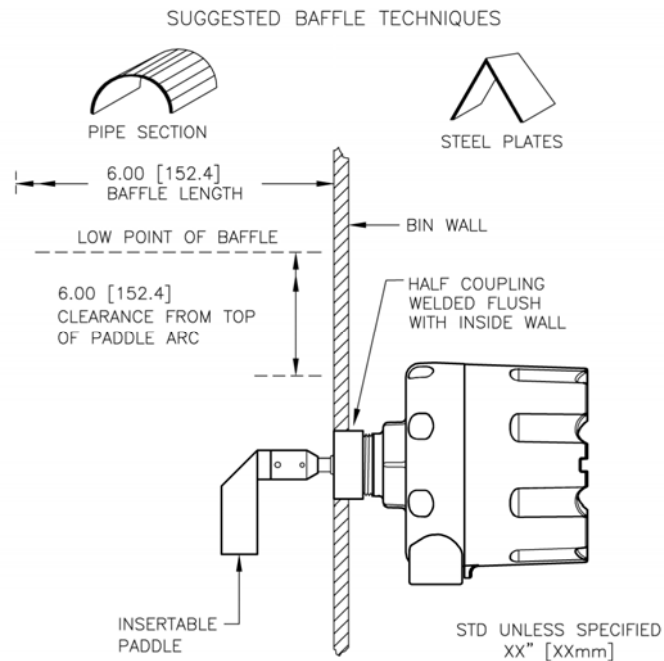

2.3 Paddle Level Switch Preparation

(1) Mounting Plate Attachment (if applicable – see Table 2 on page 11)

After using the **mounting plate** as a mounting hole template (see Section 3.1), attach the mounting plate to the PLS series unit prior to attaching to vessel. This is particularly advantageous if the paddle to be used is not the insertion type. Grease the paddle unit's threaded hub with anti-seize compound and thread the mounting plate into place until there is a snug fit. (See also ① of Figure 3 for guidance).

(2) Flexible Coupling Attachment (if applicable – see Table 2 on page 11)

Remove the **lock pin** from the PLS unit. Screw the **flex coupling** into the coupling provided on the PLS unit. Align the "through hole" within the connection and secure with lock pin. (See also ② of Figure 3 for guidance).

(3) Extension Attachment (if applicable)

Remove the **lock pin** from the PLS unit (or flex coupling). Screw the **extension** into the coupling provided on the PLS unit (or flex coupling). Align the "through hole" within the connection and secure with lock pin. (See also ③ of Figure 3 for guidance)

Note: A guard attachment should be used with rigid extensions greater than 457 mm (18 inches) in length.

(4) Guard Attachment (if applicable)

In applications using a mounting plate with a **full coupling**, slide the **1 1/4" pipe** over the shaft extension and secure to the mounting plate coupling. The shaft extension should protrude, from the guard, a distance of approximately 102 mm (4 inches). (See also ④ of Figure 3 for guidance).

When not using a mounting plate, the guard must be connected to the PLS unit with a **1 1/4" full coupling** and in some cases may require attachment *after* the PLS unit is attached to the vessel.

(5) Paddle Attachment (if applicable)

The **paddle** should be attached at this time only if it is an insertion type or if the mounting plate is being utilised. Remove the lock pin from applicable connection point (i.e. PLS unit, flex coupling or extension). Screw the paddle into the applicable coupling. Align the "through hole" within the connection and secure with the lock pin. (See also ⑤ of Figure 3 for guidance).

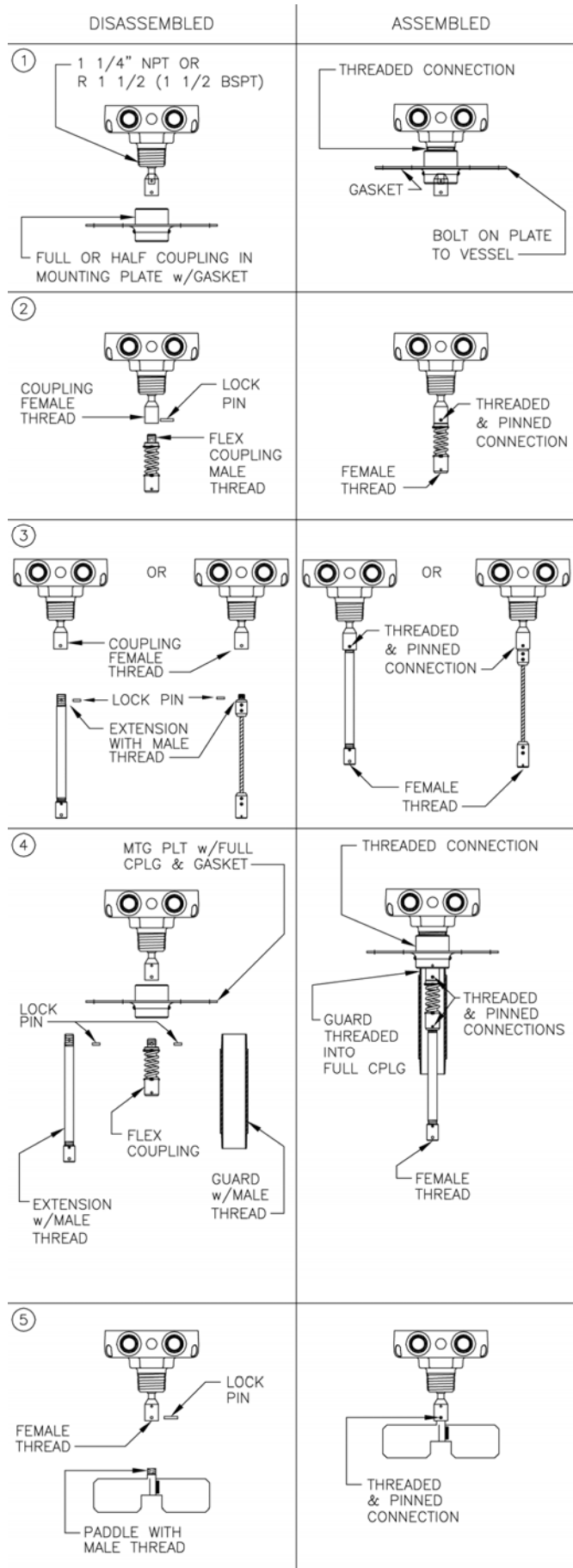

Figure 3

3 Mechanical Installation

3.1 Side Mount /Top Mount

(1) Coupling Mounting

Cut a hole into the vessel that corresponds to the outer diameter of the applicable pipe coupling.

In side-mount applications, position a **half coupling** flush with the inside of the vessel and weld into place. In top-mount applications, position a **full coupling** halfway into the vessel and weld into place.

After greasing the mounting threads with anti-seize compound, thread the PLS unit into the coupling and position the conduit entrance to minimize moisture infiltration. Attach the paddle, if applicable. (See Figure 2 for guidance).

(2) Plate Mounting

Using the **gasket**, provided with the mounting plate, as a template, drill **six holes**. The diameters of these holes depend on the attachment method being used. Drill six clearance holes at 9 mm (11/32 inch) diameter for use with 5/16" bolts. The bolts may be secured by tack welding the bolt heads to the vessel, or by an adjoining nut.

Cut a hole, suggested size 50 - 125 mm or (2 - 5 inches), centered within the bolt circle to allow an attached paddle to fit within the bin. Attach the gasket and mounting plate to the vessel, positioning the conduit entrance to minimize moisture infiltration. (See also Figure 4 for guidance).

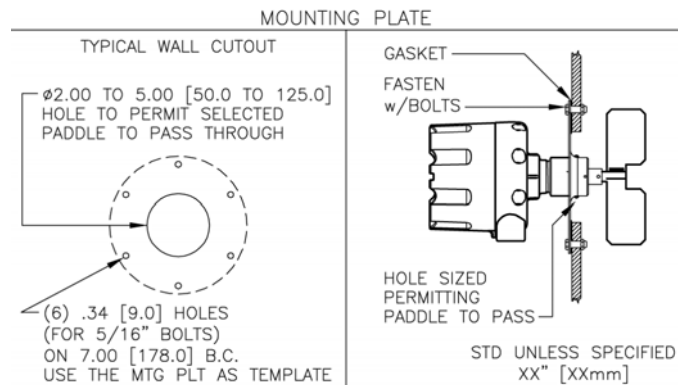

Figure 4

3.2 Extension/Guard Installation

(1) Typical Configuration

Rigid extensions are recommended for top-mounting applications only and should be always accompanied by a **flexible coupling**. Shaft guards are recommended whenever extensions are longer than 457 mm (18 inches). (See Figure 5 for guidance).

(2) Guard Reinforcement

Mechanical reinforcement of the shaft guard should be considered whenever a guard length greater than 1829 mm (72 inches) is used. The guard should be anchored to the sidewall with braces to reduce mechanical stress at the connection point of the guard. (See Figure 5 for guidance).

(3) Guard/Extension Multi-Stage Assemblies

It may be necessary to connect multiple short pieces of shaft extension to ultimately achieve the desired length. In all cases, extensions and guards **should not exceed** 3658 mm (144 inches). Shaft extensions can be simply connected to one another. Guards must use a 1¼" full coupling as an interface between sections. Couplings are available from Mobrey Measurement. (See Figure 5 for guidance).

(4) Cable Extensions

Lengths up to 1981 mm (78 inches) are permitted, but can be shortened in the field as required. See instructions provided with cable extension for details.

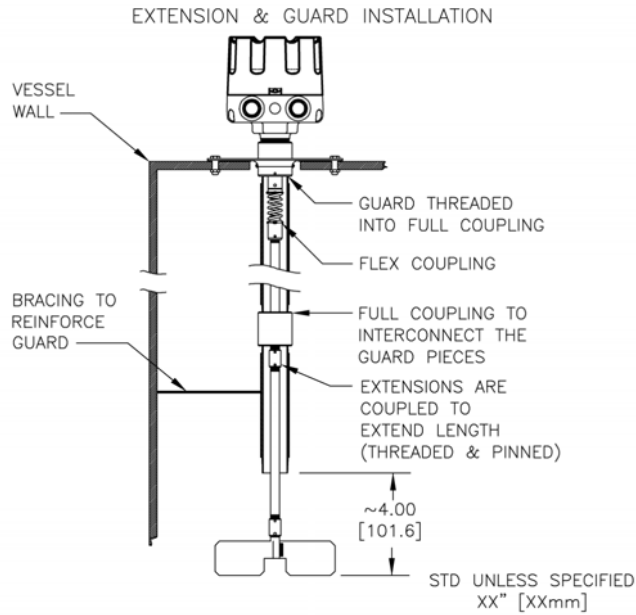

Figure 5

3.3 High-Temp Models

(1) Mounting

Carefully handle the Hi-Temp gasket provided with the assembly. Using it as a template, mark the locations of the six boltholes on the vessel. Drill six holes at the diameter applicable to the attachment method being used (i.e. tapped holes or clearance holes for bolt/nut combination).

For example, drill six clearance holes at 9 mm (11/32 inch) diameter for use with 5/16" bolts. The bolts may be secured by tack welding the bolt heads to the vessel, or by an adjoining nut. Cut a hole, suggested size 50-125 mm (2-5 inches), centered within the bolt circle to allow the paddle, when attached to the PLS unit, to fit within the vessel. Attach the gasket and Hi-Temp PLS unit to the vessel, positioning the conduit entrance in a manner that restricts moisture infiltration.

(2) Extensions/Guards

Use of extensions is permissible on Hi-Temp models of PLS units also. (See Section 3.2 for details of extensions). Installing guards on Hi-Temp models requires in-field modifications. Consult factory for guidance.

(3) Effective Cooling

The Hi-Temp PLS unit includes a **steel lagging pipe**, which thermally insulates (via lag pipe material and physical separation) the internal vessel temperature from the PLS unit, thereby protecting critical components. This technique is very effective but is dependent on careful consideration of ambient air temperature surrounding PLS unit, thermal conductivity of the material being sensed and the actual temperature present at the mounting point. The following chart is intended to provide general guidance for installation.

Each application should be evaluated to insure that the unit's operating temperature is not exceeded. In addition, an air connection is provided on the steel lagged pipe to further increase the cooling capacity of the system. When applicable, connect airline to 1/2" coupling, provided on Hi-Temp model, using only the recommended air pressure, which must exceed the vessel pressure to be effective. The air should be clean and dry and is required to be continually supplied to the Hi-Temp model to assure cooling.

Table 1

Internal Temperature	Model	Air Required	CFM
150°C (< 300°F)	Standard	None	N/A
150-260°C (300-500°F)	Hi-Temp	None	N/A
260-400°C (500-750°F)	Hi-Temp	½ psig	2.14

3.4 Electrical Connections

(1) Explosive atmospheres

Please refer to safety instruction booklet IP4004/SI when installing a PLS unit in explosive atmospheres.

(2) Factory Wiring

The industry exclusive motor shutoff feature is pre-wired at the factory and must not be altered in the field. **The jumper wire from the main terminal block to the motor switch must not be removed.**

(3) Permanently Connected Equipment

Disconnecting devices shall be included in the system installation. In installations where multiple circuits are used, individual 'disconnects' are required. The 'disconnects' shall be within close proximity of the equipment, accessible to operators, and marked appropriately as the 'disconnect' for the associated circuit. Ensure the 'disconnect' ratings are appropriately sized for the circuit protected (see specification in Section 9).

(4) Circuit Separation

Since the unit's single wiring compartment can not absolutely protect against physical contact between multiple circuits, it is required that all wiring used must have an insulation rating of 300v minimum, and a temperature rating of 105°C (221°F) minimum.

(5) Protective Earthing

Each unit is provided with a "protective conductor terminal" which shall be terminated to the local earth ground potential to eliminate shock hazard. Select wire size that can carry in excess of the sum of all circuit's maximum amperage.

(6) Power Input

Verify the intended voltage supply is compatible with the voltage configuration indicated on the external nameplate. Connect power as shown in Figure 6.

(7) Output Contacts (See Figure 6)

When the paddle is free to turn, the two switches in the PLS unit are in their normal condition (i.e. N.C. contacts are closed to COM, and N.O. contacts are open to COM). However, when material surrounds the paddle preventing it from turning, the motor rotates on a switch actuating plate which activates the switches into opposite from normal condition (i.e. N.C. contacts are open to COM, and N.O. contacts are closed to COM).

When selecting which switch to wire, the following should be considered:

Motor Switch:

- (a) The load must be capable of operating at the same voltage as the unit's motor.
- (b) The load must be tolerant of periodic on and off switching which is caused by minor paddle motion during sensing condition.
- (c) The load must not exceed the rated current capacity of the switch (See Specifications).

Isolated Switch:

- (a) Any voltage within limits of the switch can be connected independent of the motor voltage. (See Specifications).
- (b) This switch permits minor amounts of paddle motion without constant "on and off" signaling.
- (c) The load must not exceed the rated current capacity of the switch (See Specifications).

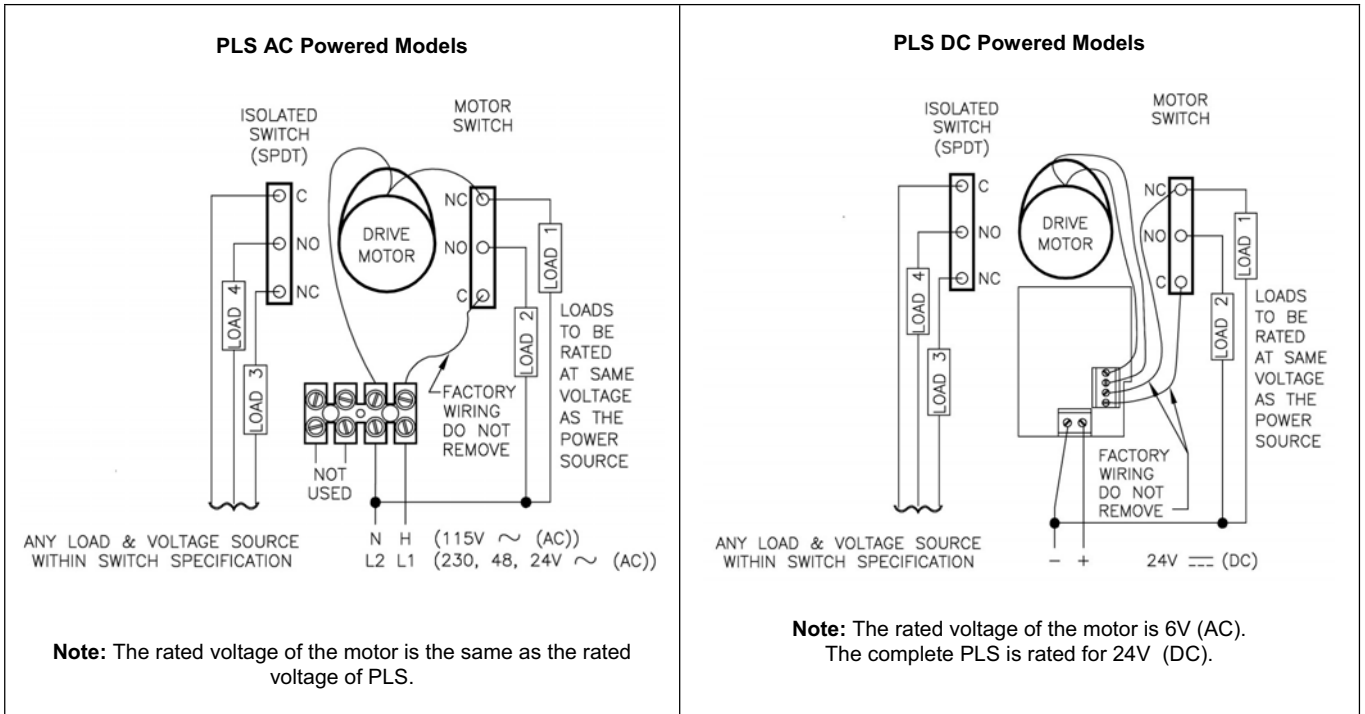

Figure 6

4 Set-up

4.1 Paddle Selection

The best calibration is achieved by proper paddle selection. Incorrect paddle selection may lead to false sensing and therefore a poor calibration. Mobrey Measurement offers a variety of interchangeable paddle assemblies to meet the needs of a wide variety of applications. Different material densities, particle sizes and flow characteristics require specific paddles to provide optimum performance.

Ensure that the paddle being used for the application corresponds with the recommendations found in Table 2.

Table 2

		Scimitar	Single Vane	3 Vane Standard	3 Vane Large	2 Vane	4 Vane	Triangular	Belt Vane
Application (+H/L level)									
Heavy material > 2000 kg/m ³ > 40mm Ø	High								■ *
	Low								■ *
Heavy material > 2000 kg/m ³ < 40mm Ø	High		■ *			■ *	■ *		
	Low		■ *			■ *	■ *		
Medium material 250 - 1000 kg/m ³	High	■		■			■	■	
	Low	■	■	■			■	■	
Light material up to 250 kg/m ³	High	■			■			■	
	Low	■			■			■	
Mounting:		Insertion	Insertion	Plate or flange	Plate or flange	Plate or flange	Plate or flange	Plate or flange	Plate or flange
Notes:		* = Flexible coupling required ■ = Recommended							

4.2 Sensitivity Spring

(1) Setting upon Receipt

All PLS units are shipped from the factory with the **spring tension** preset at the mid-range sensitivity setting. In most applications this setting results in acceptable operation, assuming proper paddle selection. The setting can be verified by locating the **cotter pin** holding the spring to the switch bracket frame. For mid-range sensitivity, the cotter pin will be inserted into the middle hole. (See Figure 7 for guidance).

(2) Increased Sensitivity

When sensing extremely light materials (less than 10 lbs/ft³ or 160kg/m³), it is desirable to move the cotter pin to the hole which exerts minimum spring tension. The reduced spring tension will permit switch actuation with less material restriction at the paddle. (See Figure 7 for guidance).

(3) Decreased Sensitivity

When sensing extremely heavy materials (greater than 75 lbs/ft³ or 1200kg/m³) or materials which have a tendency to stick or build up around shaft seal, it is desirable to move the cotter pin to the hole which exerts maximum spring tension. The increased spring tension will require greater material restriction at the paddle but will prevent cases of the sensor remaining in the activated condition when material is absent. (See Figure 7 for guidance).

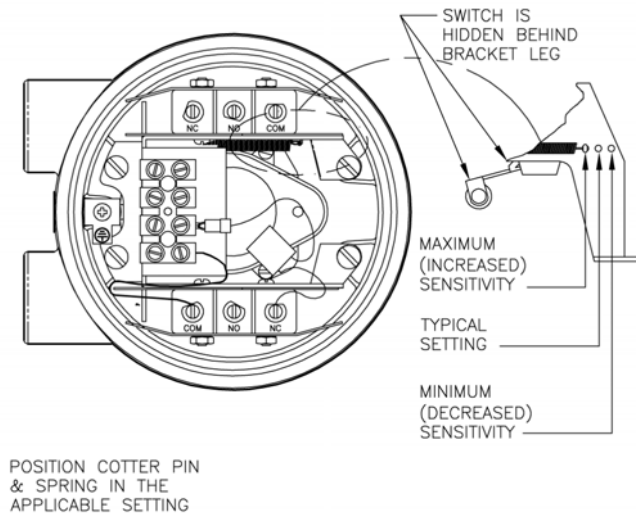

Sensitivity Spring Adjustment

Figure 7

5 Troubleshooting

PROBLEM: The paddle does not rotate when material is absent and the sensor is in "no sensing" mode.

CAUSE/SOLUTION:

- (1) Verify electrical power is connected to the proper terminations (See wiring diagrams) and that it is the proper voltage as depicted on the cover.
- (2) Verify jumper wire is in place between the power terminal and the motor switch (See wiring diagrams).
- (3) Verify motor operation by connecting the two motor leads directly to the incoming power. Motor will rotate if operational. Reconnect motor leads.
- (4) Verify condition of motor switch by measuring voltage between its COM and NC terminals. Replace the switch if a voltage reading equivalent to the power source exists.
- (5) Verify if motor is rotating. Replace the clutch mechanism if the motor is turning but the paddle is not.

PROBLEM: The paddle does not rotate when material is absent and the sensor is in "sense" mode.

CAUSE/SOLUTION:

- (1) Verify condition of sensitivity spring. It should not be cut, broken or excessively stretched to the point that it loses its ability to retract motor to "no sense" condition. Replace if necessary.
- (2) Verify status of material around shaft and hub of rotary paddle bin monitor. Excessive buildup may restrict shaft from returning to "no sense" condition. Clean material buildup.
- (3) Verify if drive shaft is free to rotate by manually twisting paddle. If rotation is restricted, replace the outer seal and the two internal bearings.

PROBLEM: The paddle rotates but material is not sensed when the paddle is covered.

CAUSE/SOLUTION:

- (1) Verify isolated switch is activated prior to the motor switch when the paddle is halted. If sequence is incorrect, realign switches on the bracket. Consult the factory if problem persists.
- (2) Verify switch operation by measuring continuity while in the "sense" and "no sense" modes. Replace switches if contact states are incorrect.
- (3) Verify that the paddle being used in the application follows the guidelines outlined in Table 2. Change paddle to one capable of sensing lighter material.

6 Maintenance

6.1 Motor Replacement

(Follow this procedure in conjunction with Figure 8).

Procedure:

- (1) Disconnect power source from PLS unit.
- (2) Disconnect motor leads from incoming terminal block and from motor switch.
- (3) Remove the four screws holding the switch bracket assembly to the housing. Drape switch bracket over the side of the housing so the motor is completely accessible. Do not over extend the spring.
- (4) Remove the two screws holding the motor to the actuator plate thereby freeing motor.
- (5) Install new motor and retain with two screws.
- (6) Install the switch bracket and fasten with four screws.
- (7) Fasten motor leads to terminal block and motor switch on AC models. Fasten motor leads to PCB on DC models. Lead orientation does not matter.
- (8) Reconnect the power source to the rotary paddle bin monitor.

6.2 Switch Replacement or Addition

(Follow this procedure in conjunction with Figure 8).

Procedure:

- (1) Disconnect power source from the rotary paddle bin monitor.
- (2) Remove the four screws holding the switch bracket assembly to the housing. Raise the bracket out of housing far enough to access the switches. DO NOT over extend the spring.
- (3) Disassemble the switch from the switch bracket by removing the screws and nuts. Replace switch and reassemble using the same insulation barriers and hardware.
- (4) (Applicable to DPDT switches only) On the switch actuator plate, the ramp that causes the switch lever to be activated must be bent downward on a 90 degree angle in order to provide proper operation. If necessary, remove the motor and the switch actuator plate and bend the ramp with a pair of pliers. The motor switch should not be changed to a DPDT type.
- (5) Install the switch bracket and fasten with four screws. Twist the external drive shaft and verify both switches are actuating. The isolated switch should always activate before the motor switch.
- (6) Reconnect the power source to the PLS unit.

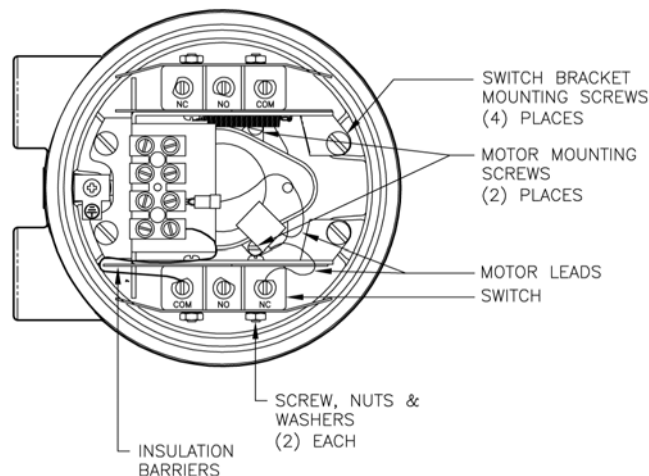

Motor and Switch replacement

Figure 8

7 Mechanicals

NOTE: DIMENSIONS ARE SHOWN IN INCHES WITH MILLIMETER EQUIVALENT IN BRACKETS.

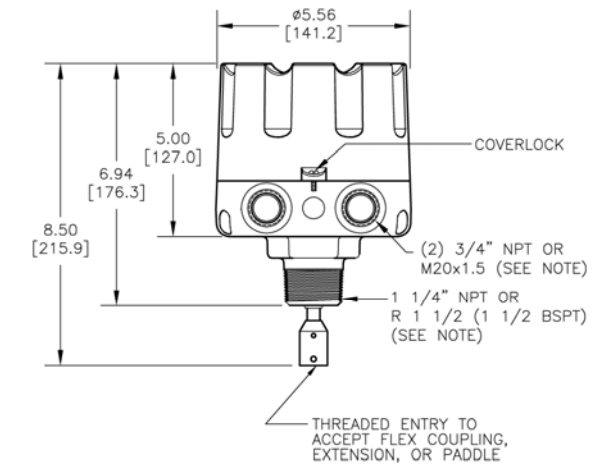

NOTE:

- 1. 3/4" NPT AVAILABLE ONLY ON 1 1/4" NPT EQUIPPED ENCLOSURE. M20x1.5 AVAILABLE ONLY ON 1 1/2 BSPT EQUIPPED ENCLOSURE.

STD UNLESS SPECIFIED XX" [XXmm]

Standard Model

Figure 9

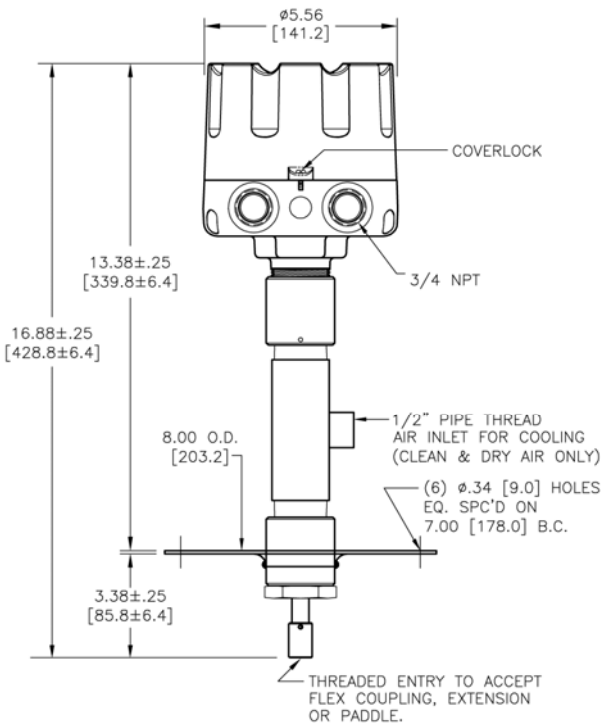

STD UNLESS SPECIFIED XX" [XXmm]

High Temp Model

Figure 10

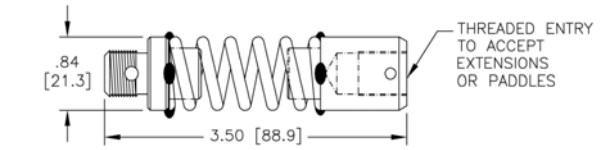

Flexible Coupling

Figure 11

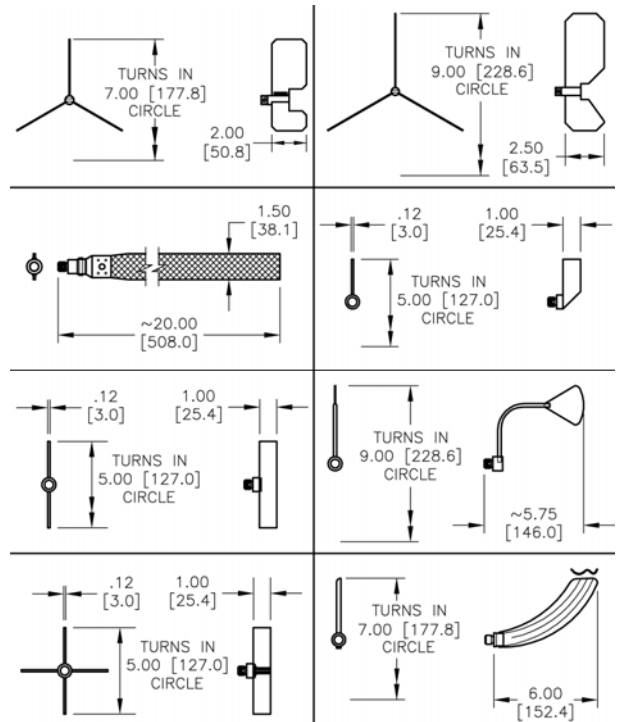

Paddles

Figure 12

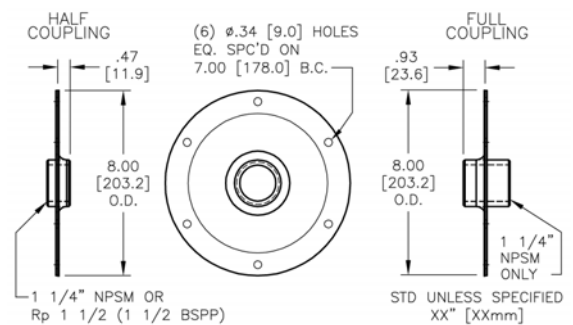

Mounting Plate

Figure 13

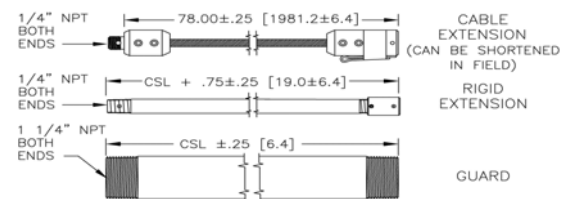

Extensions and Guards

Figure 14

8 Safety



General Safety

CAUTION: It is essential that all instructions in this manual be followed to ensure proper operation of the equipment and safety of operating personnel. The use of this symbol is used throughout manual to highlight important safety issues. Please pay particular attention to these items.



Electrical Shock Caution:

Certain PLS Series units are powered with a HIGH VOLTAGE. No operator serviceable parts are inside. All servicing is to be performed by qualified personnel. Each PLS Series unit is provided with a "protective conductor terminal" which shall be terminated to earth ground potential (see Electrical Installation details in Section 3.4).

This product's design complies with EN61010-1 installation category II and pollution degree 2.



Hazardous Location Caution

Certain PLS Series units can be used in Hazardous Locations (see specification in Section 9). These models shall only be used in applications covered by stated ratings or those considered non-hazardous. Failure to comply could result in damage to personnel and property. The following must be maintained to assure safe operation:

(1) Enclosure integrity - the PLS is manufactured from aluminium and stainless steel with nitrile rubber seals. The user or installer should consider the performance of these materials with regard to attack by aggressive substances that may be present in a hazardous location. The dimensions of the housing, cover or drive-shaft shall not be altered.

(2) Maintenance - Power to all circuits must be disconnected before conducting any investigation, setup or maintenance.

Please also refer to safety instruction booklet IP4004/SI when installing a PLS unit in explosive atmospheres.

Electromagnetic Compatibility (EMC)

The PLS Series unit was tested and found to comply with the standards listed below. It should not be used in residential or commercial environments. Compliance to the EMC standards was demonstrated by means of a test setup using the following installation methods:

(1) PLS Series unit enclosure was connected to earth ground (protective earth).

(2) No specific wiring convention was used to supply power or to retrieve output signal from the PLS Series unit.

EMC Emissions:

Meets: EN 61326-1: Electrical Equipment for Control Use, EMC.
 EN 55011: Radiated and conducted emissions (Class A - industrial).
 EN 61000-3: Fluctuations/Flicker.

Meets: FCC Part 15B: RF Devices, Unintentional Radiators.
 CISPR 11: Radiated and conducted emissions (Class A - industrial).

EMC Immunity:

Meets: EN 61326-1: Electrical Equipment for Control Use, EMC.
 IEC 61000-4-2: Electrostatic discharge (industrial).
 IEC 61000-4-3: RF radiated EM fields (industrial).
 IEC 61000-4-4: Electrical fast transients (industrial).
 IEC 61000-4-5: Electrical surges (industrial).
 IEC 61000-4-6: RF conducted EM energy (industrial).
 IEC 61000-4-8: Power frequency magnetic fields (industrial).
 IEC 61000-4-11: Source voltage deviation.

9 Specification

Power Supply:	115 V ac \pm 15%, 50/60 Hz 230 V ac \pm 15%, 50/60 Hz 24 V dc \pm 15%.
Power consumption:	4W maximum.
Outputs:	2 x SPDT control relays, 15A at 250 V ac.
Operating temperature:	-40°C to +149°C -40°C to +399°C (Hi-Temp Unit only).
Ambient temperature:	-40°C to +93°C.
Operating pressure:	2 bar maximum.
Housing material:	Aluminum alloy, powder paint coating.
Housing rating:	IP66.
Conduit connection:	Two (2) ¾" NPT or Two (2) M20 cable glands.
Mounting Connection:	1 ¼" NPT <i>or</i> R 1 ½ BSPT (except Hi-Temp unit).
Weight:	Typical standard model is approximately 4 kg.
Wetted parts:	Type 304 Stainless Steel
Approvals:	ATEX II 1/2 D T 100°C
(Pending)	<i>UL and CSA Class I, Div. 1 & 2, Groups C, D. Class II, Div. 1 & 2, Groups E, F, G</i>
Sensitivity:	80 kg/m ³ minimum material density (when using large 3-vane paddle).

10 Warranty

Mobrey Measurement warrants each PLS unit to be free from defects in material and workmanship under normal use and service within two (2) years from the date of purchase. The purchaser must give notice of any defect to Mobrey Measurement within the warranty period, return the product intact and prepay transportation charges.

The obligation of Mobrey Measurement under this warranty is limited to repair or replacement at its factory. This warranty shall not apply to any product which is repaired or altered outside of the Mobrey Measurement factory, or which has been subject to misuse, negligence, accident, incorrect wiring by others or improper installation.

Mobrey Measurement reserves the right to change the design and/or specifications without prior notice.

Level

The Emerson logo is a trade mark and service mark of Emerson Electric Co.

Rosemount is a registered trademark of Rosemount Inc.

Mobrey is a registered trademark of Mobrey Ltd.

All other marks are the property of their respective owners.

We reserve the right to modify or improve the designs or specifications of product and services at any time without notice.



International:

Emerson Process Management

Mobrey Measurement

158 Edinburgh Avenue, Slough,
Berks, SL1 4UE, UK

Tel: +44 (0)1753 756600

Fax: +44 (0)1753 823589

www.mobrey.com

Americas:

Emerson Process Management

Rosemount Inc

8200 Market Boulevard
Chanhassen, MN USA 55317

Tel: (US) (800) 999-9307

Tel: (International) (952) 906-8888

Fax: (952) 949-7001

www.rosemount.com

