

Sensor/actuator box - SACB-8/ 8-L-SC SCO P - 1453025

Please be informed that the data shown in this PDF Document is generated from our Online Catalog. Please find the complete data in the user's documentation. Our General Terms of Use for Downloads are valid (<http://phoenixcontact.com/download>)



Sensor/actuator box, application: Standard, connection method: M12-SPEEDCON-socket Plastic, number of slots: 8, number of positions: 4, coding: A - standard, slot assignment: single, status display: yes, pnp; master cable connection: Spring-cage connection 180°, shielding: No

Why buy this product

- Safety in the field, thanks to molded housing and high degree of protection
- Flexible, distributed bundling of signals in one master cable
- Convenient: increased machine availability thanks to quick and easy diagnostics
- Save time, thanks to installation with SPEEDCON fast locking system
- Flexible: distributor box with connector hood for on-site assembly



Key Commercial Data

Packing unit	1 STK
GTIN	 4 046356 553643
GTIN	4046356553643
Weight per Piece (excluding packing)	224.200 g
Custom tariff number	85366990
Country of origin	Poland

Technical data

General

Rated voltage	24 V DC
Max. operating voltage U_{max}	30 V DC
Current carrying capacity per I/O signal	2 A
Current carrying capacity per slot	4 A
Total rated current	12 A
Number of positions	4
Number of slots	8
Flammability rating according to UL 94	V0

Sensor/actuator box - SACB-8/ 8-L-SC SCO P - 1453025

Technical data

General

Sensor/actuator connection system	M12-SPEEDCON-socket
Note	<p>When connecting the signal lines to the black PCB terminal blocks, please use a 0.4 x 2.0 mm screwdriver.</p> <p>The black PCB terminal blocks only require a minimal amount of operating force.</p> <p>Screwdriver: SZS 0,4X2,0 - 1205202</p> <p>Using larger screwdrivers or excessive force may damage the PCB terminal blocks.</p> <p>When using ferrules, the wires can be inserted straight into the PCB terminal blocks without opening the clamping area.</p>
	<p>Item 1412060 SACB-8/16-L-PT SCO P is a version with the same connection cross section for signals and energy supply from 0.2 mm² to 1 mm². This sensor/actuator box with double slot assignment also features a master cable connection with Push-in connection terminal blocks.</p>

Ambient conditions

Degree of protection	IP65
	IP67
Ambient temperature (operation)	-25 °C ... 80 °C

Local diagnostics function

Local diagnostics	Supply voltage Green LED
	Status display I/O Yellow LED

Master cable data/connection data

Connection method	Spring-cage connection
Conductor cross section min. (signal)	0.2 mm ²
Conductor cross section max. (signal)	0.5 mm ²
Conductor cross section AWG min. (signal)	24
Conductor cross section AWG max. (signal)	20
Stripping length (signal)	6 mm
Conductor cross section min. (energy)	0.2 mm ²
Conductor cross section max. (energy)	1.5 mm ²
Conductor cross section AWG min. (energy)	24
Conductor cross section AWG max. (energy)	16
Stripping length (power)	10 mm
External cable diameter min.	7 mm
External cable diameter max.	12 mm
Stripping length	50 mm (Master cable)
Tightening torque, cover screw	1 Nm
Tightening torque, union nut	2.5 Nm
Tightening torque slot sensor/actuator cable	0.4 Nm
Tightening torque of mounting screw for fixing the housing	0.5 Nm

Insulation material

Housing material	PBT
------------------	-----

Sensor/actuator box - SACB-8/ 8-L-SC SCO P - 1453025

Technical data

Insulation material

Material of the moulding mass	PUR
Contact material	Cu alloy
Contact surface material	gold-plated
Contact carrier material	PA
Material of threaded sleeve	PBT
O-ring material	NBR
Sealing material	NBR (Connector hood)

Pin assignment

Slot/position = Wire color or connection	1 / 4 (A) = WH
	2 / 4 (A) = GN
	3 / 4 (A) = YE
	4 / 4 (A) = GY
	5 / 4 (A) = PK
	6 / 4 (A) = RD
	7 / 4 (A) = BK
	8 / 4 (A) = VT
	1-8 / 1 (+ 24 V) = BN
	1-8 / 3 (0 V) = BU
	1-8 / 5 (PE) = GN/YE

Standards and Regulations

Standard designation	M12 connector
Standards/regulations	IEC 61076-2-101
Connection in acc. with standard	CUL
Flammability rating according to UL 94	V0

Environmental Product Compliance

China RoHS	Environmentally friendly use period: unlimited = EFUP-e
	No hazardous substances above threshold values

Drawings

Sensor/actuator box - SACB-8/ 8-L-SC SCO P - 1453025

Schematic diagram

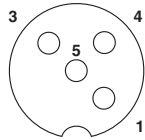

M12 slot, socket, 4-pos.

Dimensional drawing

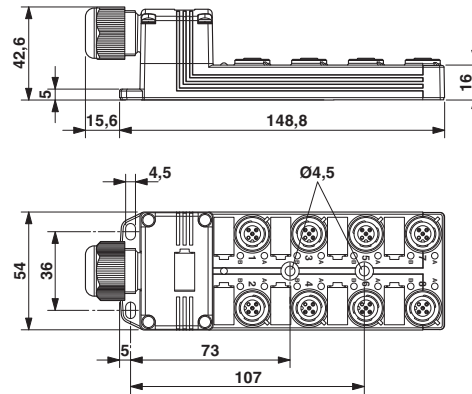

Circuit diagram

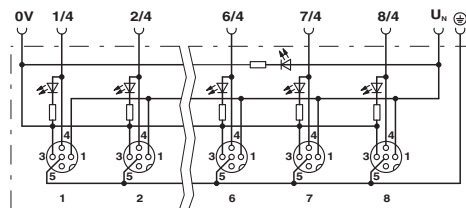

Classifications

eCl@ss

eCl@ss 4.0	27140815
eCl@ss 4.1	27140815
eCl@ss 5.0	27143423
eCl@ss 5.1	27143423
eCl@ss 6.0	27143423
eCl@ss 7.0	27449001
eCl@ss 8.0	27279219
eCl@ss 9.0	27440108

ETIM

ETIM 4.0	EC002585
ETIM 5.0	EC002585
ETIM 6.0	EC002585

Sensor/actuator box - SACB-8/ 8-L-SC SCO P - 1453025

Classifications

UNSPSC

UNSPSC 6.01	31261501
UNSPSC 7.0901	31261501
UNSPSC 11	31261501
UNSPSC 12.01	31261501
UNSPSC 13.2	31251501

Approvals

Approvals

Approvals

UL Recognized / cUL Recognized / EAC / cULus Recognized

Ex Approvals

Approval details

UL Recognized		http://database.ul.com/cgi-bin/XYV/template/LISEXT/1FRAME/index.htm	FILE E 118976
Nominal current IN		4 A	
Nominal voltage UN		24 V	

cUL Recognized		http://database.ul.com/cgi-bin/XYV/template/LISEXT/1FRAME/index.htm	FILE E 118976
Nominal voltage UN		24 V	

EAC		EAC-Zulassung
-----	--	---------------

cULus Recognized		http://database.ul.com/cgi-bin/XYV/template/LISEXT/1FRAME/index.htm
------------------	--	---

Accessories

Accessories

Sensor/actuator box - SACB-8/ 8-L-SC SCO P - 1453025

Accessories

Cable by the meter

Master cable ring - SACB- 8X0,34/ 3X0,75-50,0 PUR - 1503344



Master cable for sensor/actuator boxes, with PE conductor, unshielded, material PUR/PVC, 11-pos., 8 x 0.34 mm² and 3 x 0.75 mm²

Connector

Ferrule - A 0,5 - 6 - 3200218



Ferrule, sleeve length: 6 mm, length: 6 mm, color: silver

Ferrule - A 0,75-10 - 3200234



Ferrule, sleeve length: 10 mm, length: 10 mm, color: silver

Ferrule - A 1 -10 - 3200250



Ferrule, sleeve length: 10 mm, length: 10 mm, color: silver

Ferrule - A 1,5 -10 - 3200276



Ferrule, sleeve length: 10 mm, length: 10 mm, color: silver

Device marking

Sensor/actuator box - SACB-8/ 8-L-SC SCO P - 1453025

Accessories

Snap-in markers - UC-EM (17,5X9) - 0827490



Snap-in markers, Sheet, white, unlabeled, can be labeled with: BLUEMARK CLED, BLUEMARK LED, CMS-P1-PLOTTER, PLOTMARK, mounting type: snapped into marker carrier, lettering field size: 17.5 x 9 mm

Snap-in markers - UCT-EM (17,5X9) - 0801491



Snap-in markers, Sheet, white, unlabeled, can be labeled with: THERMOMARK PRIME, THERMOMARK CARD, BLUEMARK CLED, BLUEMARK LED, TOPMARK LASER, mounting type: snapped into marker carrier, lettering field size: 17.5 x 9 mm

Snap-in markers - UC-EM (17,5X9) YE - 0827494



Snap-in markers, Sheet, yellow, unlabeled, can be labeled with: BLUEMARK CLED, BLUEMARK LED, CMS-P1-PLOTTER, PLOTMARK, mounting type: snapped into marker carrier, lettering field size: 17.5 x 9 mm

Snap-in markers - UCT-EM (17,5X9) YE - 0801492



Snap-in markers, Sheet, yellow, unlabeled, can be labeled with: THERMOMARK PRIME, THERMOMARK CARD, BLUEMARK CLED, BLUEMARK LED, TOPMARK LASER, mounting type: snapped into marker carrier, lettering field size: 17.5 x 9 mm

Labeled device marker

Snap-in markers - UC-EM (17,5X9) CUS - 0828238



Snap-in markers, can be ordered: by sheet, white, labeled according to customer specifications, mounting type: snapped into marker carrier, lettering field size: 17.5 x 9 mm

Sensor/actuator box - SACB-8/ 8-L-SC SCO P - 1453025

Accessories

Snap-in markers - UCT-EM (17,5X9) CUS - 0801575



UniCard sheet, for labeling devices from other manufacturers, for overview table see download area, labeled according to customer specifications

Snap-in markers - UC-EM (17,5X9) YE CUS - 0828239



Snap-in markers, can be ordered: by sheet, yellow, labeled according to customer specifications, mounting type: snapped into marker carrier, lettering field size: 17.5 x 9 mm

Snap-in markers - UCT-EM (17,5X9) YE CUS - 0801576



UniCard sheet, for labeling devices from other manufacturers, for overview table see download area, labeled according to customer specifications

Mounting rail adapter

Electronic housing - UTA 136 - 2853996

Universal DIN rail adapter, for screwing on switchgear



Protective cap

Screw plug - PROT-MS SCO - 1553129



M12 screw plug with SPEEDCON quick locking for unoccupied M12 sockets of the sensor/actuator cables, boxes and flush-type connectors

Screwdriver tools

Sensor/actuator box - SACB-8/ 8-L-SC SCO P - 1453025

Accessories

Adapter insert - TSD-M SAC-BIT ADAPTER - 1212600



Adapter bit for TSD-M...torque tools, E6.3-1/4" drive with 4 mm hexagon to accommodate SAC bits

Tool - SAC BIT M12-D15 - 1208432



Nut for assembling sensor/actuator cables with M12 connector and M12 connectors for assembly, with a knurl diameter of 15 mm, for 4 mm hexagonal drive

Tool - SACC BIT M12-D20 - 1208445



Nut for assembling M12 connectors for assembly with a knurl diameter of 20 mm, for 4 mm hexagonal drive

Philips screwdriver - SZK PZ2 VDE - 1206463



Screwdriver, PZ crosshead, VDE insulated, size: PZ 2 x 100 mm, 2-component grip, with non-slip grip

Tool - SAC BIT HOOD-W 24 - 1212486



Nut for assembling pressure nuts with 24 mm wrench size, for 4 mm hexagonal drive

Sensor/actuator box - SACB-8/ 8-L-SC SCO P - 1453025

Accessories

Screw insert - SF-BIT-PZ 2-50 - 1212592



Screw bit, PZ crosshead, E6.3-1/4" drive, size: PZ 2 x 50 mm, hardened, suitable for holder according to DIN 3126-F6.3/ISO 1173

Screwdriver - SZS 0,4X2,0 - 1205202



Micro screwdriver, bladed, size: 0.4 x 2.0 x 60 mm, 2-component grip, with non-slip grip and twist cap

Torque tool

Torque screwdriver - TSD 04 SAC - 1208429



Torque screwdriver, with preset torque of 0.4 Nm and 4 mm hexagonal drive for M12 connectors

Torque screwdriver - TSD-M 1,2NM - 1212224



Torque screw driver, accuracy as per EN ISO 6789 standard, adjustable from 0.3 - 1.2 Nm

Torque screwdriver - TSD 25 SAC - 1212315



Torque screwdriver, with preset torque of 2.5 Nm and 4 mm hexagonal drive for the pressure nut of the connector hood

Sensor/actuator box - SACB-8/ 8-L-SC SCO P - 1453025

Accessories

Torque screwdriver - TSD-M 3NM - 1212225



Torque screw driver, accuracy as per EN ISO 6789 standard, adjustable from 1.2 - 3 Nm