

Analog Set Multifunction Timers in Slim Design for Track Mounting

- All settings are made through front panel
- Six operating modes in a single timer provides flexibility for many applications
- Economical ON-delay only models available in six, single-time ranges
- Wide timing range of 0.12 seconds to 120 hours
- Fine adjustment dial for precise time setting
- Name plates provide for easy timer identification and management
- Terminal block accepts both fork or bar-sleeve connectors



Ordering Information

■ MULTIFUNCTION TIMERS

Timing functions		ON-delay, Repeat cycle/signal OFF start, Repeat cycle/signal ON start, Signal ON/OFF-delay, Signal OFF-delay, and Interval		
Terminal form		Screw terminals		
Outputs		DPDT contact	SPDT contact	NPN/PNP transistor
Part number	AC supply voltage (50/60 Hz)	H3DR-A-AC100-240	H3DR-P-AC100-120 H3DR-P-AC200-240	—
	AC/DC supply voltage	H3DR-A-AC/DC24	H3DR-P-AC/DC24	H3DR-AS-AC/DC24
	DC supply voltage	H3DR-A-DC12	—	H3DR-AS-DC12

■ ON-DELAY ONLY TIMERS

Timing ranges	1S = 0.1 to 1 second; 5S = 0.2 to 5 seconds; 10S = 0.5 to 10 seconds; 30S = 1 to 30 seconds; 60S = 2 to 60 seconds; 10M = 0.5 to 10 minutes		
Terminal form	Screw terminals		
Output	SPDT contact		
Supply voltage	110 to 120 VAC, 50/60 Hz	220 to 240 VAC, 50/60 Hz	24 VAC/VDC
Part number	H3DR-M-AC110-120-1S	H3DR-M-AC220-240-1S	H3DR-M-AC/DC24-1S
	H3DR-M-AC110-120-5S	H3DR-M-AC220-240-5S	H3DR-M-AC/DC24-5S
	H3DR-M-AC110-120-10S	H3DR-M-AC220-240-10S	H3DR-M-AC/DC24-10S
	H3DR-M-AC110-120-30S	H3DR-M-AC220-240-30S	H3DR-M-AC/DC24-30S
	H3DR-M-AC110-120-60S	H3DR-M-AC220-240-60S	H3DR-M-AC/DC24-60S
	H3DR-M-AC110-120-10M	H3DR-M-AC220-240-10M	H3DR-M-AC/DC24-10M

■ ACCESSORIES

Description	Part number
Mounting track	DIN rail, 50 cm (1.64 ft) length
	DIN rail, 1 m (3.28 ft) length
	End plate
	Spacer
	PFP-50N
	PFP-100N
	PFP-M
	PFP-S

■ RANGE SELECTION

H3DR-A, H3DR-AS

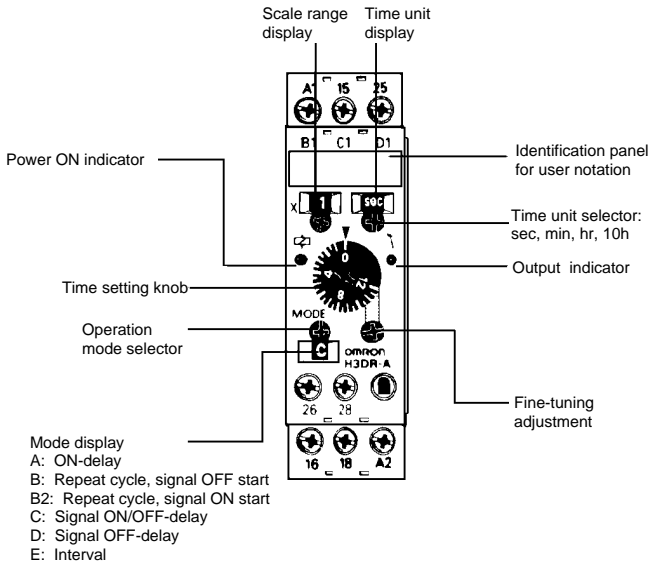

Timing unit	Seconds	Minutes	Hours	10 hours
Setting	0	Instantaneous output		
Time	x 0.1	0.12 to 1.2		1.2 to 12
scale	x 1	1.2 to 12		12 to 120

H3DR-P

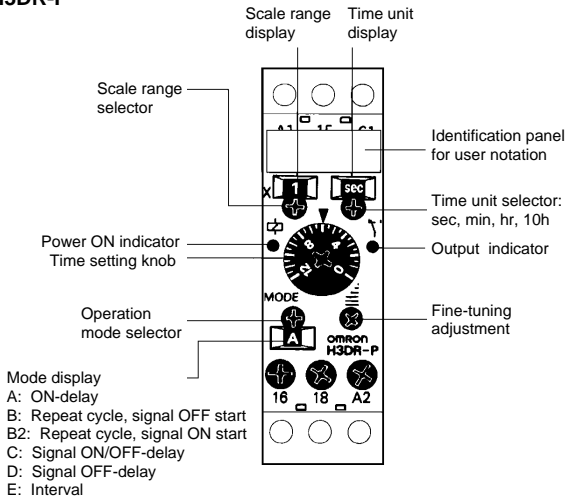

Timing unit	Seconds	Minutes	Hours	10 hours
Setting	0	Instantaneous output		
Time	x 0.1	0.12 to 1.2		1.2 to 12
scale	x 1	1.2 to 12		12 to 120

H3DR-M

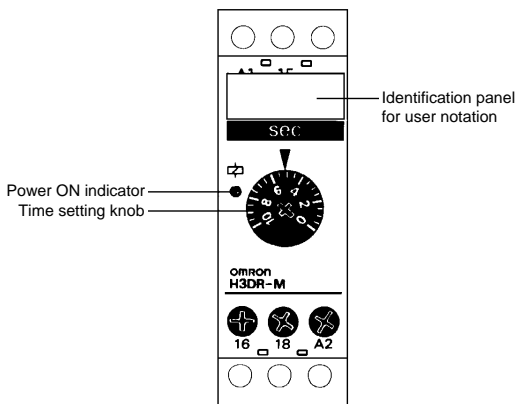

Rated time	Time range
1 s	0.1 to 1 second
5 s	0.2 to 5 seconds
10 s	0.5 to 10 seconds
30 s	1 to 30 seconds
60 s	2 to 60 seconds
10 min	0.5 to 10 minutes

Specifications

Part number		H3DR-A	H3DR-AS	H3DR-P	H3DR-M	
Supply voltage	AC	24 V or 100-240, 50/60 Hz		24 V, 100-120 V or 200-240 V, 50/60 Hz	24 V, 110-120 V or 220-240 VAC, 50/60 Hz	
	DC	12 V or 24 V		24 V	24 V	
Operating voltage		85% to 110% of rated voltage (90% to 110% with 12 VDC type)				
Power consumption	AC	10 VA		6 VA, 100-120 VAC 10 VA, 200-240 VAC 2 VA, 24 VAC	6 VA, 110-120 VAC 10 VA, 220-240 VAC 2 VA, 24 VAC	
	DC	1 W		1 W, 24 VDC	1 W, 24 VDC	
Timing functions		ON-delay, Repeat cycle/signal OFF start, Repeat cycle/signal ON start, Signal ON/OFF-delay, Signal OFF-delay, and Interval			ON-delay	
Start, reset, gate inputs*	Type	No-voltage input			—	
	ON impedance	1 k Ω max.			—	
	Residual voltage	1 V max.			—	
	OFF impedance	100 k Ω min.			—	
Control output	Type	Time limit	DPDT contact	NPN or PNP** transistor	SPDT contact	SPDT contact
		Instantaneous	—	—	—	—
	Max. load		5 A, 250 VAC (p.f. = 1)	100 mA, 30 VDC max. with 2 VDC residual voltage	5 A, 250 VAC (p.f. = 1)	5 A, 250 VAC (p.f. = 1)
		Min. load		100 mA, 5 VDC	—	100 mA, 5 VDC
Repeat accuracy		\pm 1% FS max. (1% \pm 10 ms in the 1.2 s range)			\pm 2% FS max.	
Setting error		\pm 10% FS \pm 0.05 s max.				
Resetting system		Power reset with minimum power opening time of 0.1 s				
Resetting time		0.1 s max.				
Indicators		Power (green LED), Output ON (orange LED)			Power (green LED)	
Materials		Plastic case, knob				
Mounting		DIN rail track				
Connections		Terminal screws				
Weight		120 g (4.7 oz.)				
Approvals		UL/CSA/CE (EMC) (LV)				
Operating ambient temperature		-10° to 55°C (14° to 131°F)				
Humidity		35 to 85% RH				
Vibration	Mechanical durability	10 to 55 Hz, 1.5 mm (0.06 in) double amplitude each in three directions		10 to 55 Hz with 0.75 mm (0.03 in) double amplitude each in three directions		
	Malfunction durability	10 to 55 Hz, 0.5 mm (0.02 in) double amplitude each in three directions		10 to 55 Hz with 0.5 mm (0.02 in) double amplitude each in three directions		
Shock	Mechanical durability	30 G each in three directions		100 G each in three directions		
	Malfunction durability	10 G each in three directions		10 G each in three directions		
Variation due to voltage change		\pm 0.5% FS max., \pm 0.5% \pm 10 ms max. in the 1.2 s range			\pm 2% FS max.	
Variation due to temperature change		\pm 2% FS max., \pm 0.2% \pm 10 ms max. in the 1.2 s range			\pm 5% FS max.	
Insulation resistance		100 M Ω min. at 500 VDC				
Dielectric strength		2,000 VAC, 50/60 Hz for 1 minute between current-carrying and non-current-carrying parts 2,000 VAC, 50/60 Hz for 1 minute between control output terminals and operating circuit 1,000 VAC, 50/60 Hz for 1 minute between contacts not located next to each other				
Service life	Mechanical	20 million operations minimum at 1,800 operations/hour				
	Electrical	100,000 operations minimum at 5 A, 250 VAC (p.f. = 1)				

NOTE:

*H3DR-P has start input only; H3DR-M has no inputs.

**The internal circuits are optically isolated from the output, enabling application of either NPN or PNP transistor devices.

Engineering Data

■ ELECTRICAL SERVICE LIFE

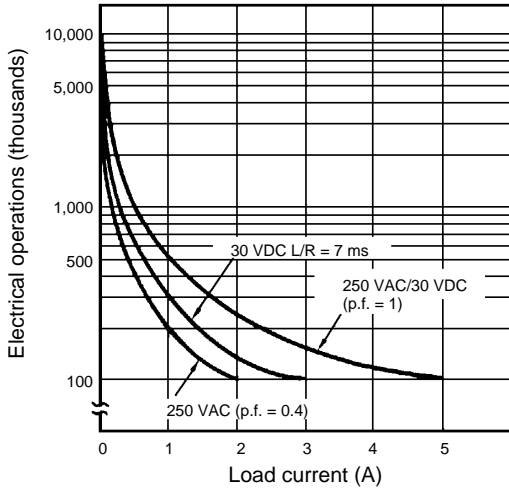

Reference:
 A maximum current of 0.15 A can be switched at 125 VDC (p.f. = 1). Maximum current of 0.1 A can be switched if L/R is 7 ms. In both cases, a life of 100,000 operations can be expected.
 The minimum applicable load is 10 mA at 5 VDC.

Timing Charts

■ H3DR-M ON-DELAY ONLY TIMER

Note: The minimum reset time is 0.1 s and the minimum signal input delay is 0.05 s.
 The letter "t" in the timing charts stands for the set time and "t-a" means that the period is less than the time set.

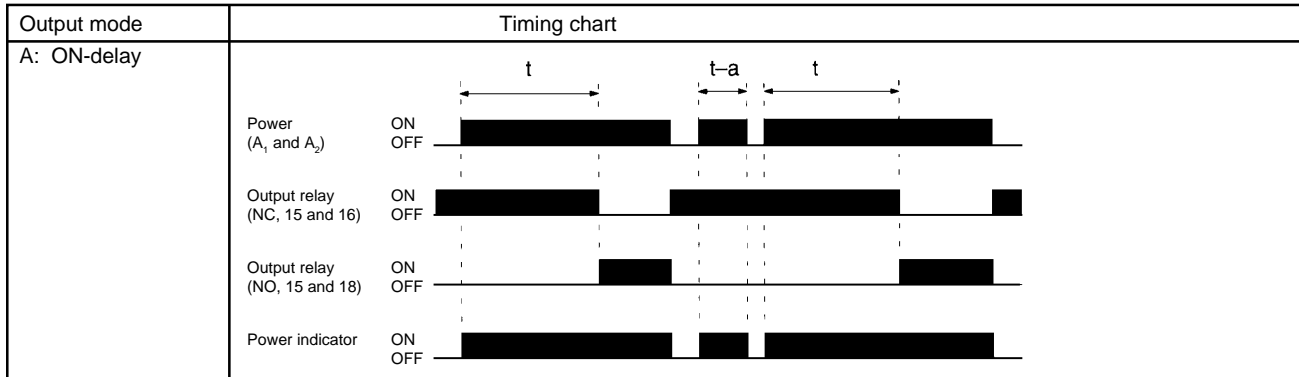

■ H3DR-P MULTI-MODE TIMER WITH POWER-OFF RESET

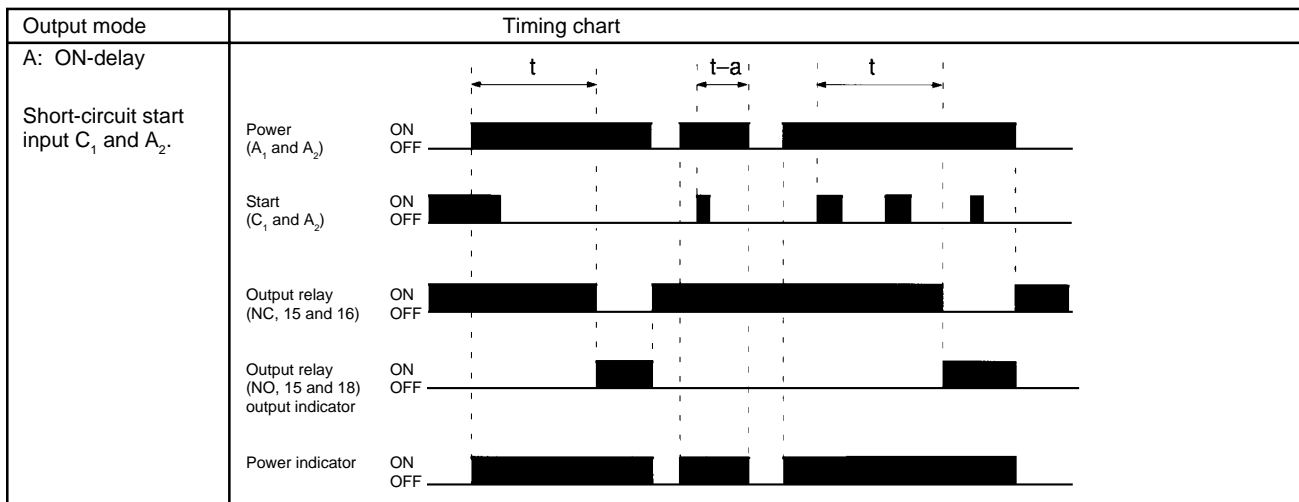

H3DR-P TIMING CHARTS continued

Output mode	Timing chart	
<p>B: Repeat cycle signal OFF start</p> <p>Short-circuit start input C₁ and A₂.</p>	<p>Power (A₁ and A₂)</p> <p>Start (C₁ and A₂)</p> <p>Output relay (NC, 15 and 16)</p> <p>Output relay (NO, 15 and 18) output indicator</p> <p>Power indicator</p>	
<p>B2: Repeat cycle signal ON start</p> <p>Short-circuit start input C₁ and A₂.</p>	<p>Power (A₁ and A₂)</p> <p>Start (C₁ and A₂)</p> <p>Output relay (NC, 15 and 16)</p> <p>Output relay (NO, 15 and 18) output indicator</p> <p>Power indicator</p>	
<p>C: Signal ON/OFF delay</p> <p>Short-circuit start input C₁ and A₂.</p>	<p>Power (A₁ and A₂)</p> <p>Start (C₁ and A₂)</p> <p>Output relay (NC, 15 and 16)</p> <p>Output relay (NO, 15 and 18) output indicator</p> <p>Power indicator</p>	

NOTE: The minimum reset time is 0.1 s and the minimum signal input delay is 0.05 s.
The letter "t" in the timing charts stands for the set time and "t-a" means that the period is less than the time set.

H3DR-P TIMING CHARTS continued

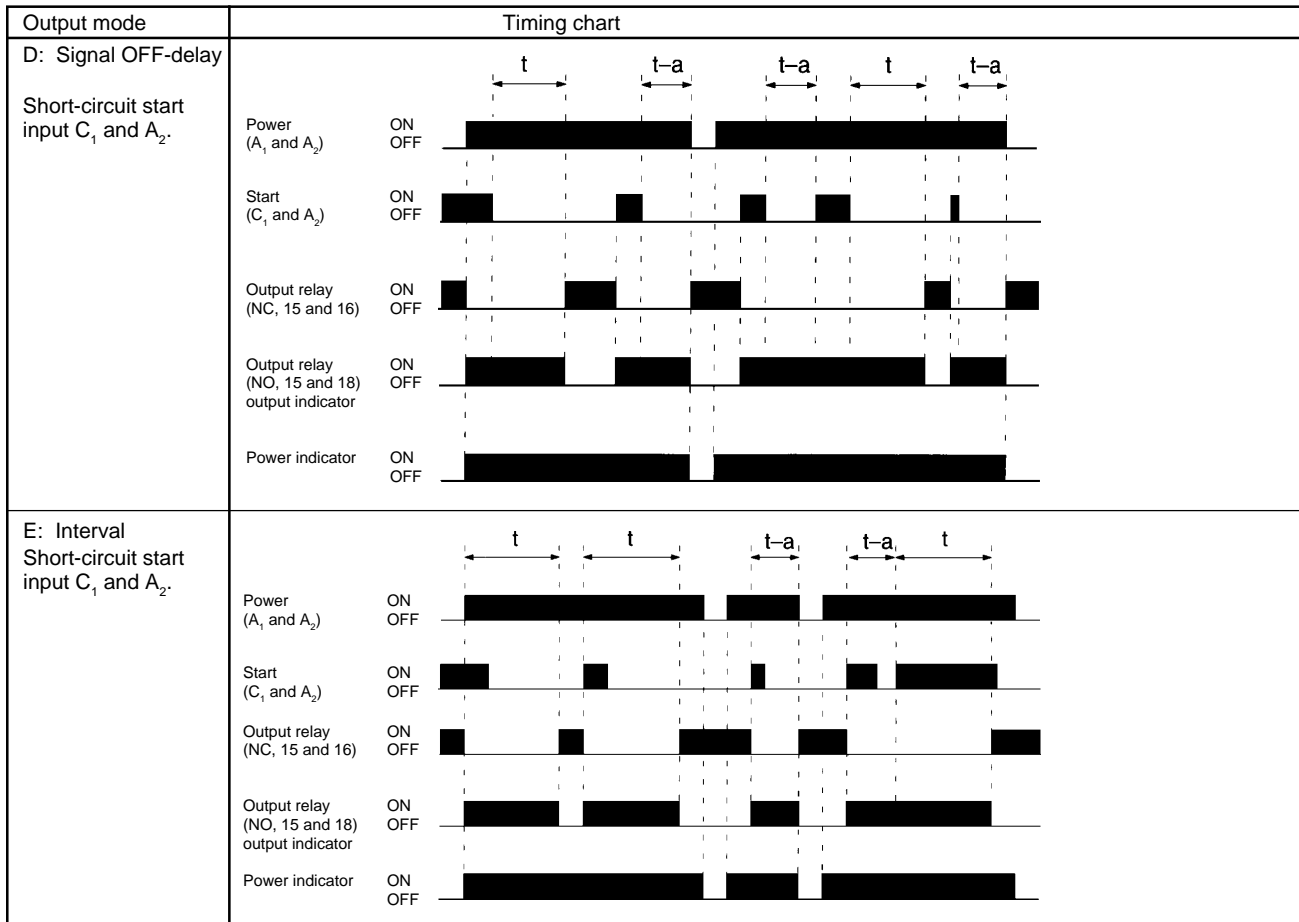

■ H3DR-A □ MULTI-MODE TIMER WITH EXTERNAL RESET AND GATE INPUTS

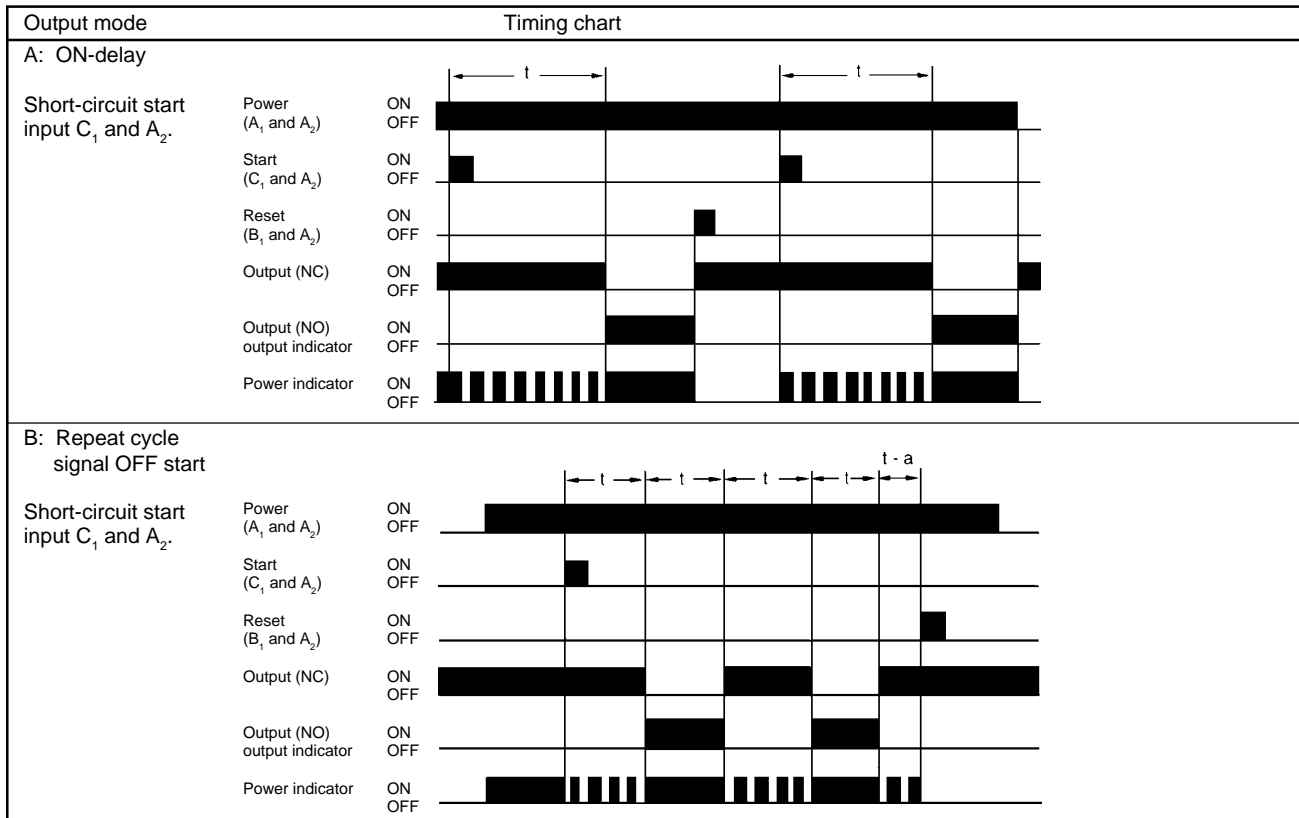

H3DR-A□ TIMING CHARTS continued

Output mode	Timing chart
<p>B2: Repeat cycle signal ON start</p> <p>Short-circuit start input C_1 and A_2.</p>	
<p>C: Signal ON/OFF delay</p> <p>Short-circuit start input C_1 and A_2.</p>	
<p>D: Signal OFF-delay</p> <p>Short-circuit start input C_1 and A_2.</p>	
<p>E: Interval</p> <p>Short-circuit start input C_1 and A_2.</p>	

H3DR-A□ TIMING CHARTS continued

Gate signal input in mode A (ON-delay).

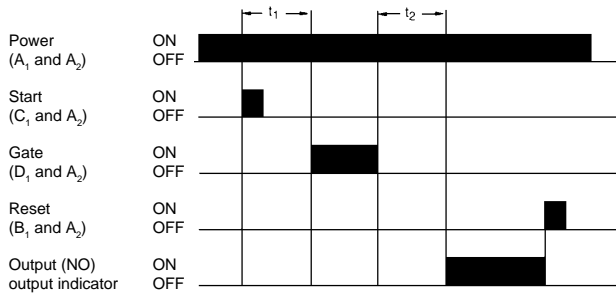

Note: The set time is the sum of t_1 and t_2 .

Dimensions

Unit: mm (inch)

■ TIMERS

H3DR-A□

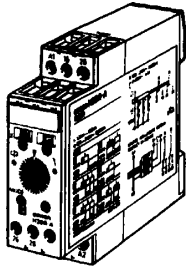

H3DR-M

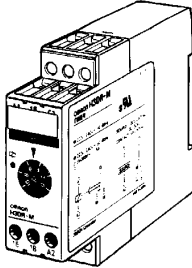

H3DR-P

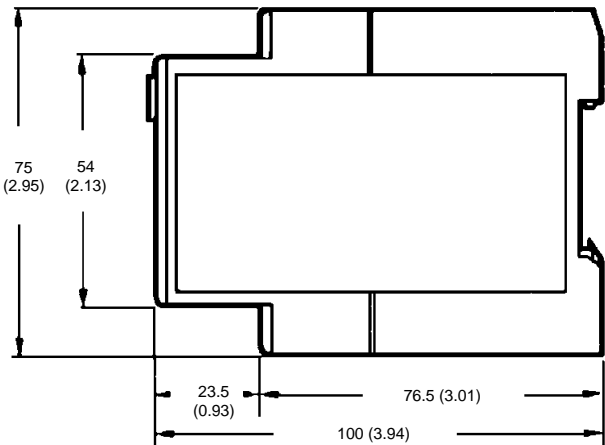
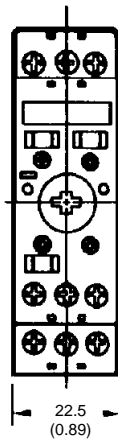
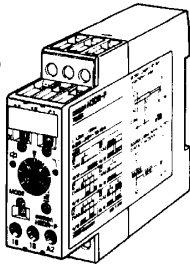

Wiring terminals accept M3 fork or a single wire.

■ MOUNTING TRACK AND ACCESSORIES

PFP-100N, PFP-50N DIN Rail Track

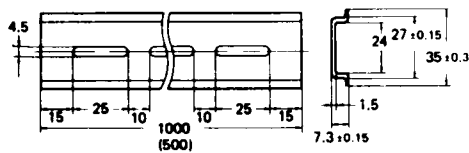

PFP-M End Plate

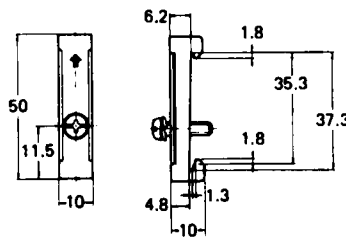

PFP-S Spacer

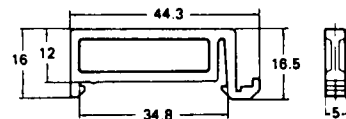

Connections

■ TERMINAL ARRANGEMENT

Part number	Input terminal number (no voltage only)				Power supply terminal numbers		Output terminal numbers		
	Start	Reset	Gate	COM	AC (common), DC -	AC (hot), DC +	COM	NC	NO
H3DR-A	C1	B1	D1	A2	A2	A1	15 25	16 26	18 28
H3DR-AS	C1	B1	D1	A2	A2	A1	15	—	18
H3DR-M	—	—	—	—	A2	A1	15	16	18
H3DR-P	C1	—	—	A2	A2	A1	15	16	18

H3DR-A DPDT Relay Output

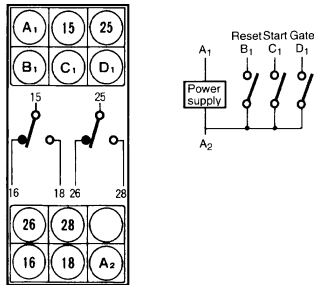

H3DR-AS Transistor Output

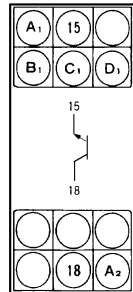

H3DR-M SPDT Relay Output

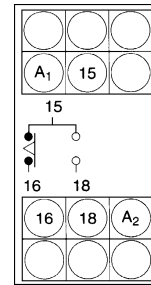

H3DR-P SPDT Relay Output

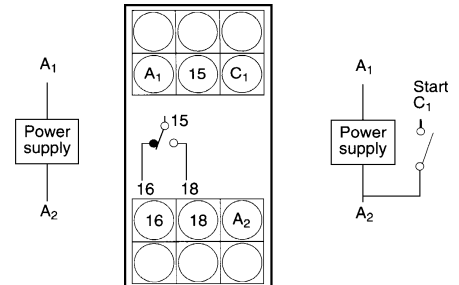

■ INPUT CONNECTIONS FOR H3DR-A AND H3DR-P

The inputs to H3DR timers are no-voltage (short circuit or open) inputs.

No-Contact, No-Voltage Input

(Connection to NPN open collector output sensor)

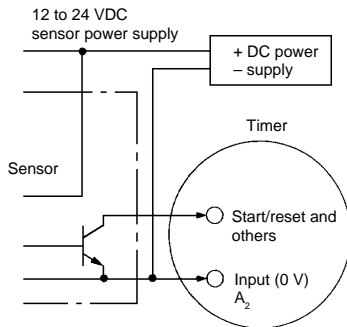

Operates with transistor ON

Contact, No-Voltage Input

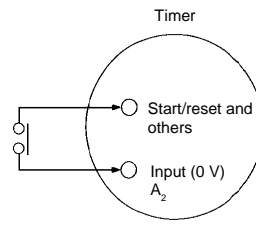

Operates with relay ON

No-Contact, No-Voltage Input

(Connection to a voltage output sensor)

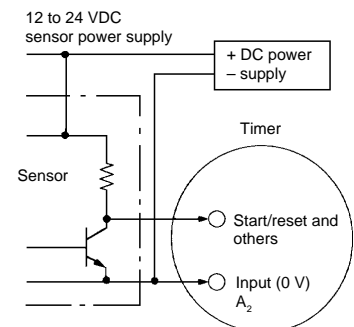

Operates with transistor ON

No-Voltage Input Signal Levels

No-contact input		Contact input
Short-circuit level	Open level	
Transistor ON Residual voltage: 1 V max. Impedance when ON: 1 kΩ max.	Transistor OFF Impedance when OFF: 100 kΩ min.	Use contacts which can adequately switch 0.1 mA at 5 V

Installation

■ POWER SUPPLIES

An AC power supply can be connected to the power input terminals without regarding polarity. A DC power supply must be connected to the power input terminals as designated according to the polarity of the terminals.

A DC power supply can be connected if its ripple factor is 20% or less and the mean voltage is within the rated operating voltage range of the timer.

Connect the power supply voltage through a relay or switch in such a way that the voltage reaches a fixed value at once or the timer may not be reset or a timer error could result.

For the power supply of an input device, use an isolating transformer, of which the primary and secondary windings are mutually isolated and the secondary winding is not grounded.

Use a commercial power supply with a sine-wave frequency of 50 or 60 Hz to supply 100 or 200 VAC.

■ INPUT AND OUTPUT PRECAUTIONS

An appropriate input is applied to the input signal terminals of the timer when the input terminal C_1 and the common terminal A_2 for the input signal are short-circuited.

WARNING: Do not connect an input terminal to any terminal other than the common terminal. Do not apply a voltage across input and common terminals or the internal circuits of the timer may be damaged.

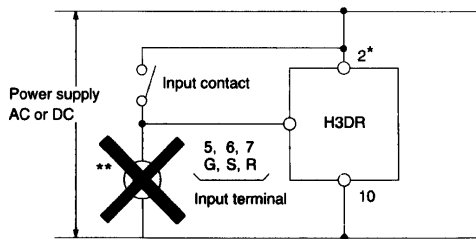

* Power supply terminal A_2 is a common terminal for the input signal (S) to the timer. Never use terminal A_1 as the common terminal for this purpose, otherwise the internal circuit of the timer may be damaged.

** Do not connect a relay or any other load between these two points, otherwise the internal circuit of the timer may be damaged due to the high-tension voltage applied to the input terminals.

When connecting a relay or a transistor as an external signal input device, pay attention to the following points to prevent short-circuiting due to a sneak current to the transformerless power supply. If a relay or transistor is connected to two or more timers, the input terminals of these timers must be wired properly so that they will not be different in phase or the terminals will be short-circuited to one another as shown below.

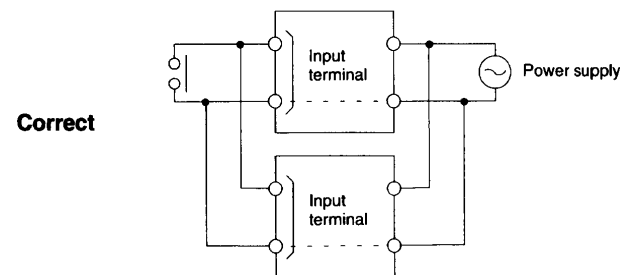
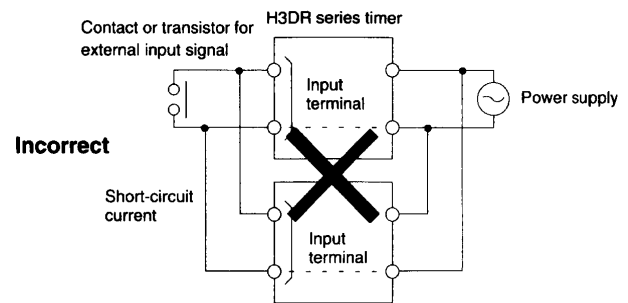

■ ENVIRONMENT

When using the timer in an area with excess electrical noise, separate the timer, wiring and the equipment which generates the input signals as far as possible from the noise sources. It is also recommended to shield the input signal wiring to prevent electrical interference.

Organic solvents (such as paint thinner), as well as very acidic or basic solutions can damage the outer casing of the timer.

Operation

■ SELECTING TIME RANGES

Be sure to turn power OFF before changing the time range. Otherwise the timer will malfunction. Use a Phillips screwdriver to select the time unit (seconds, minutes, hours or 10 hours) and the time scale range two upper turn pots. Set the time using the large central knob. On H3DR-A and H3DR-P timers, a fine-tuning adjustment helps match the timing exactly to the application.

Timing unit	Seconds	Minutes	Hours	10 hours
Setting	0	Instantaneous output		
Time	x 0.1	0.12 to 1.2		1.2 to 12
scale	x 1	1.2 to 12		12 to 120

CAUTION: Do not change the time unit, rated time, or operating mode while the timer is in operation because a malfunction could result.

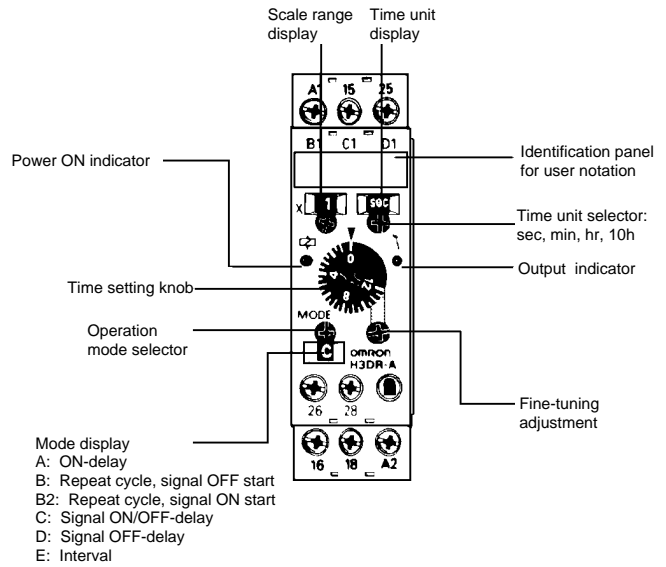

Mounting

■ TRACK MOUNTING

Mounting

Mount the H3DR timer as close to horizontal as possible.

To mount the timer on DIN rail track, hook portion (A) of the timer to the top edge of the track and then depress the timer in the direction of (B).

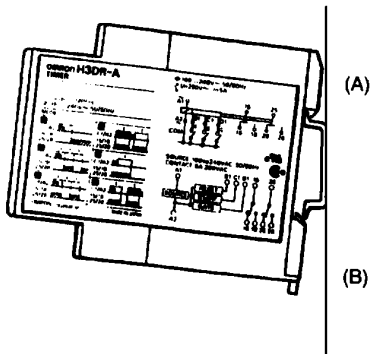

Removal

When removing the H3DR timer, pull out portion (C) with a flat-blade screwdriver and remove the timer from the mounting track.

The H3DR can be mounted and removed easily by allowing a minimum distance of 30 mm (1.18 in) between the H3DR and other equipment.

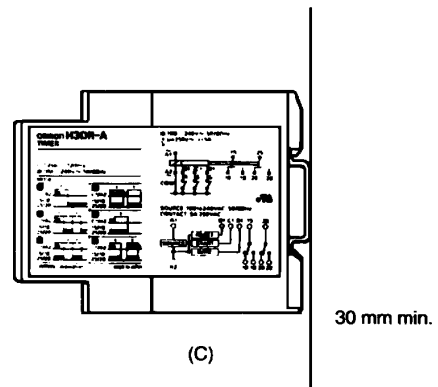

NOTE: ALL DIMENSIONS ARE IN MILLIMETERS. To convert millimeters into inches, divide by 25.4.



OMRON ELECTRONICS, INC.

One East Commerce Drive
Schaumburg, IL 60173
1-800-55-OMRON

OMRON CANADA, INC.

885 Milner Avenue
Scarborough, Ontario M1B 5V8
416-286-6465