

Absolute encoders - SSI

Shaft with clamping or synchro flange

Optical multiturn encoders 14 bit ST / 12 bit MT

GM400, GM401 - SSI



GM400 with clamping flange

Technical data - electrical ratings

Voltage supply	10...30 VDC
Reverse polarity protection	Yes
Consumption w/o load	≤50 mA (24 VDC)
Initializing time (typ.)	20 ms after power on
Interfaces	SSI, Incremental A 90° B (optional)
Function	Multiturn
Steps per turn	16384 / 14 bit
Number of turns	4096 / 12 bit
Incremental output	2048 pulses A90°B + inverted
Absolute accuracy	±0.025 °
Sensing method	Optical
Code	Gray or binary
Code sequence	CW/CCW coded by connection
Inputs	SSI clock Control signals UP/ $\overline{\text{DOWN}}$ and zero
Output circuit	SSI data: linedriver RS485 Diagnostic outputs push-pull
Interference immunity	DIN EN 61000-6-2
Emitted interference	DIN EN 61000-6-4
Diagnostic functions	Self-diagnosis Code continuity check Multiturn sensing
Approval	UL approval / E63076

Features

- Encoder multiturn / SSI
- Optical sensing
- Resolution: singleturn 14 bit, multiturn 12 bit
- Clamping or synchro flange
- Electronic setting of zero point
- Counting direction input
- Suitable for high positive, negative accelerations
- Available with additional incremental output

Optional

- Stainless steel design

Technical data - mechanical design

Housing	ø58 mm
Protection DIN EN 60529	IP 54 (without shaft seal), IP 65 (with shaft seal)
Operating speed	≤10000 rpm (mechanical) ≤6000 rpm (electric)
Starting torque	≤0.015 Nm IP 54 ≤0.03 Nm IP 65
Rotor moment of inertia	20 gcm ²
Admitted shaft load	≤20 N axial ≤40 N radial
Materials	Housing: steel Flange: aluminium
Operating temperature	-25...+85 °C -40...+85 °C (optional)
Relative humidity	95 % non-condensing
Resistance	DIN EN 60068-2-6 Vibration 10 g, 16-2000 Hz DIN EN 60068-2-27 Shock 200 g, 6 ms
Weight approx.	400 g
Connection	Connector M23, 12-pin Cable 1 m
GM400	
Shaft	ø10 mm
Flange	Clamping flange
GM401	
Shaft	ø6 mm
Flange	Synchro flange

Absolute encoders - SSI

Shaft with clamping or synchro flange

Optical multiturn encoders 14 bit ST / 12 bit MT

GM400, GM401 - SSI

Part number

Clamping flange

GM400.

				<u>Pulses / Incremental output</u>
				02 No incremental output
				04 2048 pulses / push-pull
				06 2048 pulses / RS422
				07 2048 periods, Sin/Cos 1 Vpp
				<u>Connection</u>
				A0 Connector M23, 12-pin, axial
				A1 Connector M23, 12-pin, radial
				A2 Connector M23, 12-pin, axial, for incremental output 04/06/07
				A3 Connector M23, 12-pin, radial, for incremental output 04/06/07
				11 Cable 1 m, axial
				21 Cable 1 m, radial
				<u>Voltage supply / signals</u>
				10 10...30 VDC / gray code 25 bit
				12 10...30 VDC / binary code 25 bit
				20 10...30 VDC / gray code 24 bit
				30 10...30 VDC / gray code 25 bit + parity
				40 10...30 VDC / gray code 24 bit + DV
				90 10...30 VDC / gray code 26 bit
				92 10...30 VDC / binary code 26 bit
				<u>Flange / Shaft</u>
				0 Clamping flange / ø10 mm IP 54
				A Clamping flange / ø10 mm IP 65

Synchro flange

GM401.

				<u>Pulses / Incremental output</u>
				02 No incremental output
				04 2048 pulses / push-pull
				06 2048 pulses / RS422
				07 2048 periods, Sin/Cos 1 Vpp
				<u>Connection</u>
				A0 Connector M23, 12-pin, axial
				A1 Connector M23, 12-pin, radial
				A2 Connector M23, 12-pin, axial, for incremental output 04/06/07
				A3 Connector M23, 12-pin, radial, for incremental output 04/06/07
				11 Cable 1 m, axial
				21 Cable 1 m, radial
				<u>Voltage supply / signals</u>
				10 10...30 VDC / gray code 25 bit
				12 10...30 VDC / binary code 25 bit
				20 10...30 VDC / gray code 24 bit
				30 10...30 VDC / gray code 25 bit + parity
				40 10...30 VDC / gray code 24 bit + DV
				90 10...30 VDC / gray code 26 bit
				92 10...30 VDC / binary code 26 bit
				<u>Flange / Shaft</u>
				1 Synchro flange / ø6 mm IP 54
				B Synchro flange / ø6 mm IP 65

Absolute encoders - SSI

Shaft with clamping or synchro flange

Optical multiturn encoders 14 bit ST / 12 bit MT

GM400, GM401 - SSI

Accessories

Connectors and cables

Z 130.001	Female connector M23, 12-pin, less cable
Z 130.003	Female connector M23, 12-pin, 2 m cable
Z 182.001	Female connector M23, 12-pin, less cable (incr.)
Z 182.003	Female connector M23, 12-pin, 2 m (incr.)

Mounting accessories for GM400

Z 119.006	Eccentric fixing, single
Z 119.013	Adaptor plate for clamping flange for modification into synchro flange
Z 119.017	Mounting angle for clamping flange

Mounting accessories for GM401

Z 119.006	Eccentric fixing, single
Z 119.015	Mounting adaptor for synchro flange
Z 119.035	Bearing flange for encoders with synchro flange

Data transfer

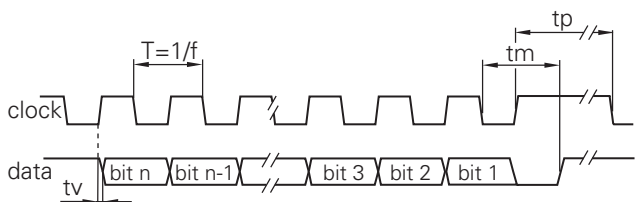

Clock frequency f	62.5...1500 kHz
Scan ratio of T	40...60 %
Time lag tv	150 ns
Monoflop time tm	25 μs + T/2
Clock interval tp	30 μs

Trigger level

SSI	Circuit
SSI-Clock	Optocoupler
SSI-Data	Linedriver RS485

Control inputs

Control inputs	Input circuit
Input level High	>0.7 UB
Input level Low	<0.3 UB
Input resistance	10 kΩ

Diagnostic outputs or Incremental outputs

Diagnostic outputs or Incremental outputs	Output circuit Push-pull circuit-proof
Output level High	>UB -3.5 V (I = -20 mA)
Output level Low	<0.5 V (I = 20 mA)
Load High	<20 mA
Load Low	<20 mA

Incremental outputs

Incremental outputs	Linedriver RS422
Output level High	>2.5 V (I = -20 mA)
Output level Low	<0.5 V (I = 20 mA)
Load High	<20 mA
Load Low	<20 mA

Outputs

Outputs	Sine / Cosine
Output level	1 Vpp ±10 %
Load	<10 mA

Absolute encoders - SSI

Shaft with clamping or synchro flange

Optical multiturn encoders 14 bit ST / 12 bit MT

GM400, GM401 - SSI

Terminal significance	
UB	Encoder voltage supply.
GND	Encoder ground connection relating to UB.
Data+	Positive, serial data output of differential linedriver.
Data-	Negative, serial data output of differential linedriver.
Clock+	Positive SS clock input. Clock+ together with clock- forms a current loop. A current of approx. 7 mA towards clock+ input means logic 1 in positive logic.
Clock-	Negative SSI clock input. Clock- together with clock+ forms a current loop. A current of approx. 7 mA towards clock- input means logic 0 in positive logic.
Zero setting	Input for setting a zero point anywhere within the programmed encoder resolution. The zero setting operation is triggered by a High impulse and has to be in line with the selected direction of rotation (UP/DOWN). Connect to GND after setting operation for maximum interference immunity. Impulse duration ≥ 100 ms.
$\overline{\text{DATAVALID}}$	Diagnostic output. An error warning is given at level Low. Important: Interferences must be drained by the downstream electronics.
$\overline{\text{DATAVALID MT}}$	Diagnostic output for monitoring the multiturn sensor voltage supply. Upon dropping below a defined voltage level the $\overline{\text{DV MT}}$ output is switched to Low.
$\overline{\text{UP/DOWN}}$	$\overline{\text{UP/DOWN}}$ counting direction input. This input is standard on High. $\overline{\text{UP/DOWN}}$ means ascending output data with clockwise shaft rotation when looking at flange. $\overline{\text{UP/DOWN-Low}}$ means ascending values with counterclockwise shaft rotation when looking at flange.
Incremental Outputs	Incremental tracks A 90° B and inverted.

Terminal assignment		
GM400, GM401		
Connector	Core colour	Assignment
Pin 1	brown	UB
Pin 2	black	GND
Pin 3	blue	Clock+
Pin 4	beige	Data+
Pin 5	green	Zero setting
Pin 6	yellow	Data-
Pin 7	violet	Clock-
Pin 8	brown/yellow	$\overline{\text{DATAVALID}}$
Pin 9	pink	$\overline{\text{UP/DOWN}}$
Pin 10	black/yellow	$\overline{\text{DATAVALID MT}}$
Pin 11	–	–
Pin 12	–	–

With incremental tracks sine/cosine			
Connector	Core colour	Assignment Incremental	Sine/cosine
Pin 1	brown	UB	UB
Pin 2	white	GND	GND
Pin 3	blue	Clock+	Clock+
Pin 4	green	Data+	Data+
Pin 5	grey	Zero setting	Zero setting
Pin 6	yellow	Data-	Data-
Pin 7	red	Clock-	Clock-
Pin 8	red/blue	Track B inv.	Cosine
Pin 9	pink	$\overline{\text{UP/DOWN}}$	$\overline{\text{UP/DOWN}}$
Pin 10	violet	Track a inv.	Sine
Pin 11	black	Track A	Sine
Pin 12	grey/pink	Track B	Cosine

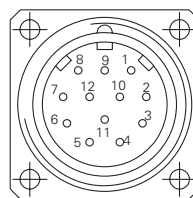

Please use cores twisted in pairs (for example clock+ / clock-) for extension cables of more than 10 m length.

Absolute encoders - SSI

Shaft with clamping or synchro flange

Optical multiturn encoders 14 bit ST / 12 bit MT

GM400, GM401 - SSI

Dimensions

GM400 - clamping flange

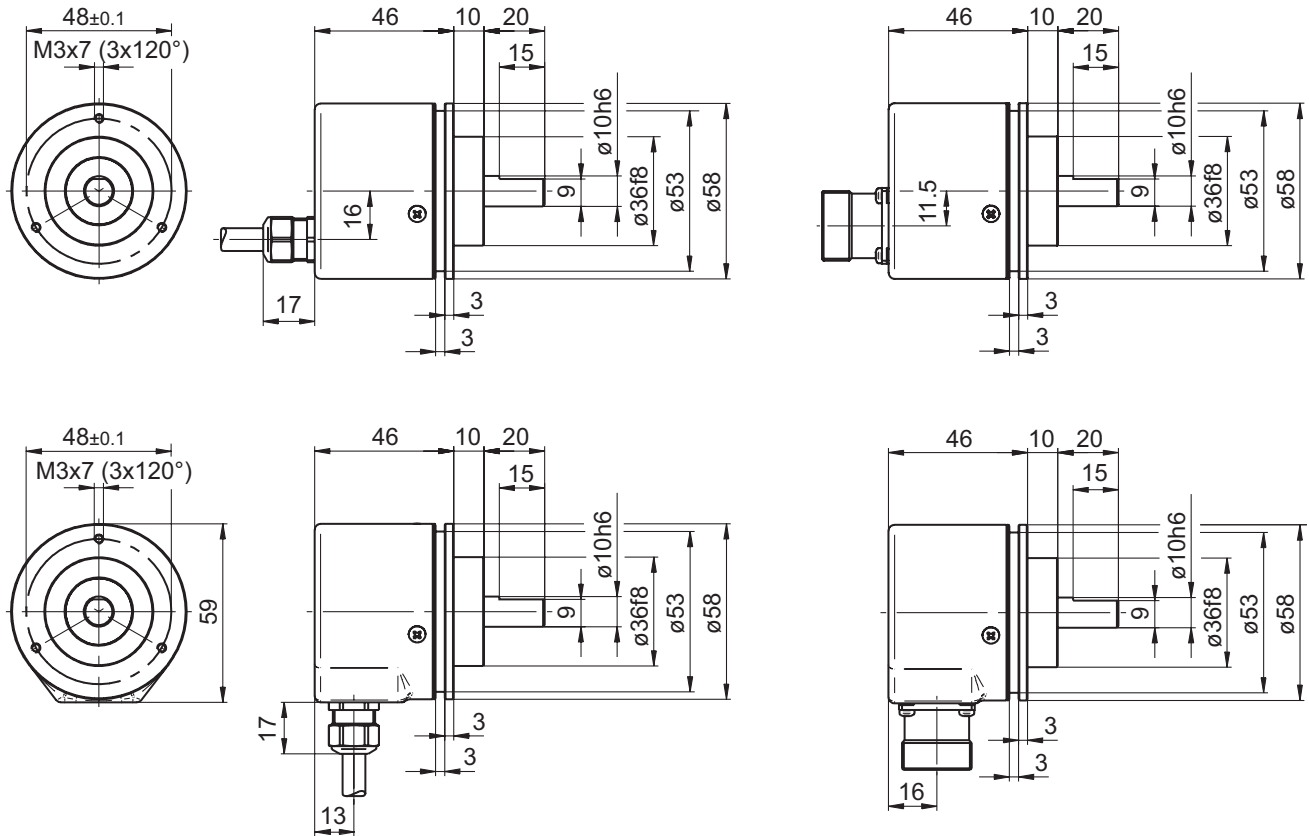

GM401 - synchro flange

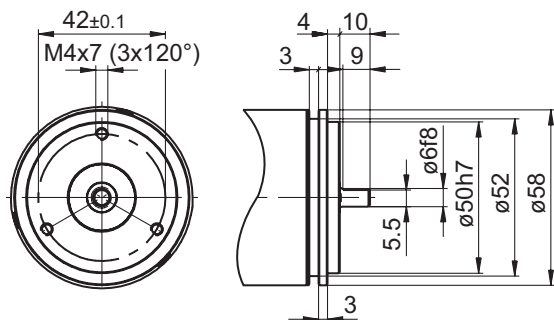

GM400, GM401 - connector dimensions

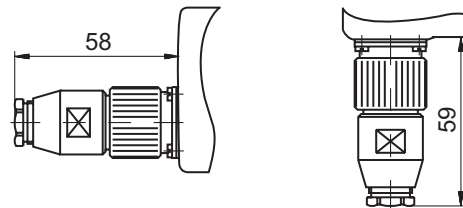

Absolute encoders - SSI
Shaft with clamping or synchro flange
Optical multiturn encoders 14 bit ST / 12 bit MT

GM400, GM401 - SSI
