

Data sheet

Servo-operated 2/2-way solenoid valves for high pressure

Type EV224B



EV224B is a high pressure indirect servo-operated 2/2-way solenoid valve with working pressure up to 40 bar, medium temperature up to 60 °C and available in NC and NO versions. Built-in pilot filter as standard, replaceable equalizing orifice, enclosures up to IP67 (depending on coil) ensure a reliable and satisfactory function.

Features

- For compressed air
- Differential pressure: Up to 40 bar
- Ambient temperature: Up to 60 °C
- Media temperature from -10 – 60 °C
- Coil enclosure: Up to IP67
- Thread connection: From G ½ – G 1
- Built in filter for protection of pilot system
- NC and NO versions

Brass valve body, NC



Connection ISO 228/1	Seal material	Orifice size	kv - value [m ³ /h]	Differential pressure, min. to max. [bar]			Media temperature min. to max. [°C]	Code number
				BE/BB	BE/BB	BG		
				18W d.c.	10W a.c.	12W a.c., 20W d.c.		
G ½	NBR	15	4	0.3 – 30	0.3 – 40	0.3 – 40	-10 – 60	032U8360
G ¾	NBR	20	8	0.3 – 30	0.3 – 40	0.3 – 40	-10 – 60	032U8362
G 1	NBR	25	11	0.3 – 30	0.3 – 40	0.3 – 40	-10 – 60	032U8364

Brass valve body, NO



Connection ISO 228/1	Seal material	Orifice size	kv - value [m ³ /h]	Differential pressure, min. to max. [bar]			Media temperature min. to max. [°C]	Code number
				BE/BB	BE/BB	BG		
				18W d.c.	10W a.c.	12W a.c., 20W d.c.		
G ½	NBR	15	4	0.3 – 30	0.3 – 40	0.3 – 40	-10 – 60	032U8361
G ¾	NBR	20	8	0.3 – 30	0.3 – 40	0.3 – 40	-10 – 60	032U8363
G 1	NBR	25	11	0.3 – 30	0.3 – 40	0.3 – 40	-10 – 60	032U8365

Technical data

Main type	EV224B 15	EV224B 20	EV224B 25
Time to open [ms] ¹⁾	40	40	50
Time to close [ms] ¹⁾	150	150	150

¹⁾ The times are indicative and apply to water. The exact times will depend on the pressure conditions. Closing times can be changed by replacement of the equalising orifice.

Type	EV224B		
Installation	Vertical solenoid system is recommended.		
Max. test pressure	64 bar		
Ambient temperature	Coil type: BB	10 W a.c. / 18 W d.c.	Up to 60 °C
	Coil type: BE	10 W a.c. / 18 W d.c.	Up to 60 °C
	Coil type: BG	12 W a.c. / 20 W d.c.	Up to 60 °C
Viscosity	Max. 50 cSt		
Materials	Valve body:	Brass	W.no. 2.0402
	Armature:	Stainless steel	W.no. 1.4105/AISI 430FR
	Armature tube:	Stainless steel	W.no. 1.4306/AISI 304L
	Armature stop:	Stainless steel	W.no. 1.4105/AISI 430FR
	Diaphragm valve cone:	Stainless steel	W.no. 1.4404/AISI 316L
	Springs:	Stainless steel	W.no. 1.4310/AISI 301
	O-rings:	NBR	-
	Valve plate:	NC: NBR / NO: PTFE	-
Diaphragm:	NBR	-	

Dimensions and weight, NC and NO

Type	L [mm]	B [mm]	B ₁ [mm] Coil type		H [mm]	H ₁ [mm]	Weight without coil [kg]
			BB/BE	BG			
EV224B 15	80	52	46	68	99	15	0.8
EV224B 20	90	58	46	68	103	18	1.0
EV224B 25	109	70	46	68	113	22	1.4

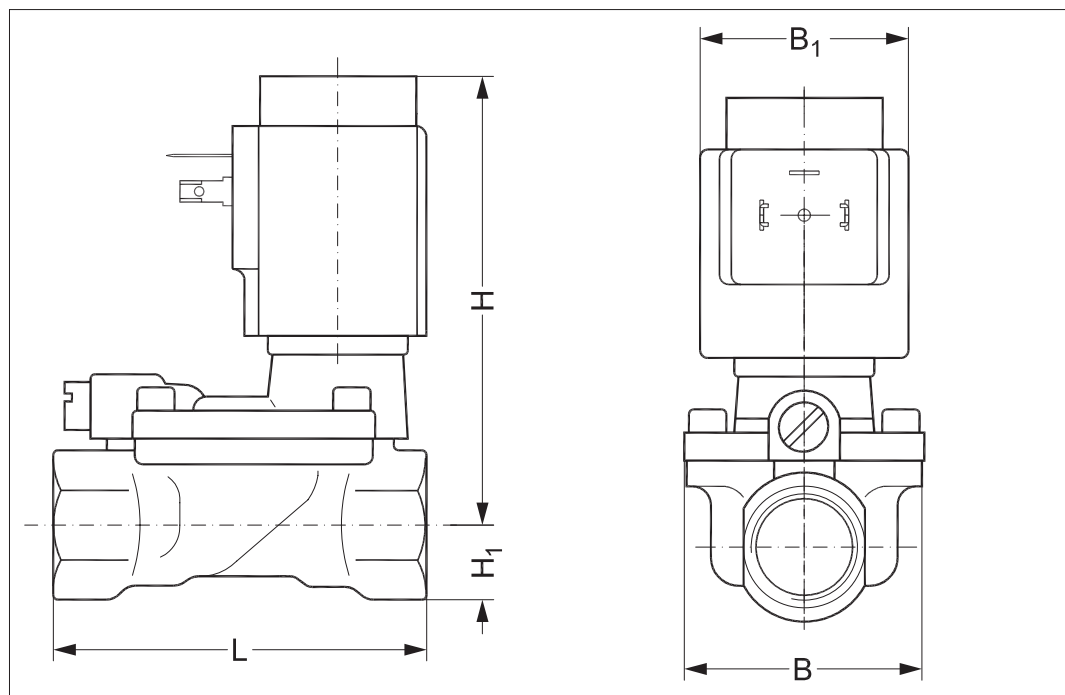

Dimensions

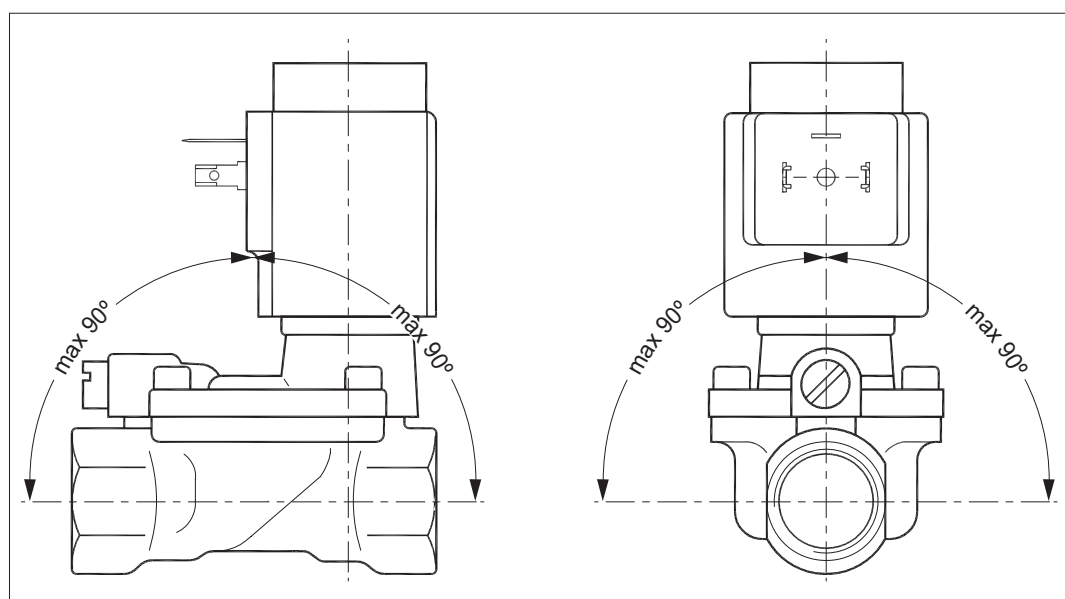

Mounting angle



Below coils can be used with EV224B

Coil	Type	Power consumption	Enclosure	Features
	BB, clip on	10 W a.c. 18 W d.c.	IP00 with spade connector	IP20 with protective cap, IP65 with cable plug
	BE, clip on	10 W a.c. 18 W d.c.	IP67	With terminal box
	BG, clip-on	12 W a.c. 20 W d.c.	IP67	With terminal box

Accessories:
Cable plug

Application	Code number
GDM 2011 (grey) cable plug according to DIN 43650-A PG11	042N0156

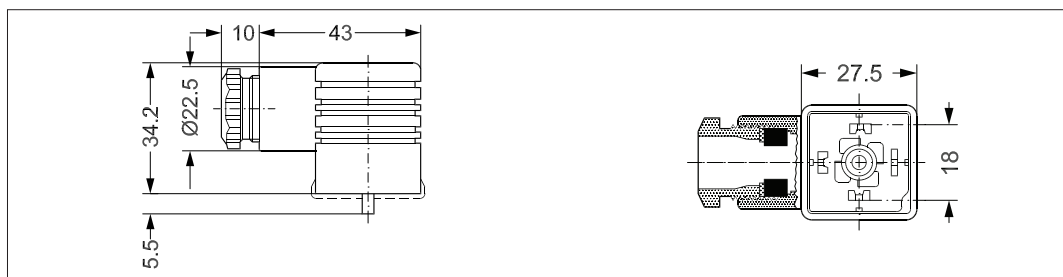

Spare parts kit, NC

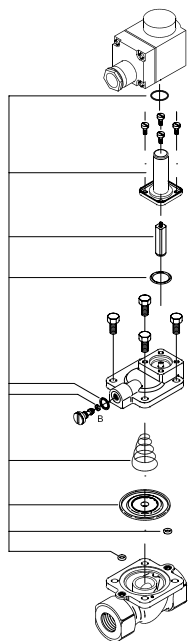

Type	Seal material	Code number
EV224B 15	NBR	032U6156
EV224B 20	NBR	032U6158
EV224B 25	NBR	032U6160

The kit contains:

- O-ring for coil
- Armature with valve plate and spring
- O-ring for the armature tube
- Spring
- Diaphragm
- 2 O-rings for the pilot system
- Gasket for the equalising orifice with o-ring

Spare parts kit, NO

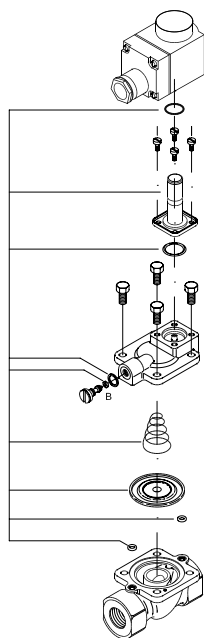

Type	Seal material	Code number
EV224B 15	NBR	032U6157
EV224B 20	NBR	032U6159
EV224B 25	NBR	032U6161

The kit contains:

- O-ring for coil
- Armature unit assembly
- O-ring for the armature unit
- Spring and diaphragm
- Two O-rings for the pilot system
- Gasket for the equalising orifice with o-ring

Function, NC

- 1.Coil
- 2.Armature spring
- 3.Valve plate
- 4.Pilot orifice
- 5.Diaphragm
- 6.Main orifice
- 7.Equalising orifice

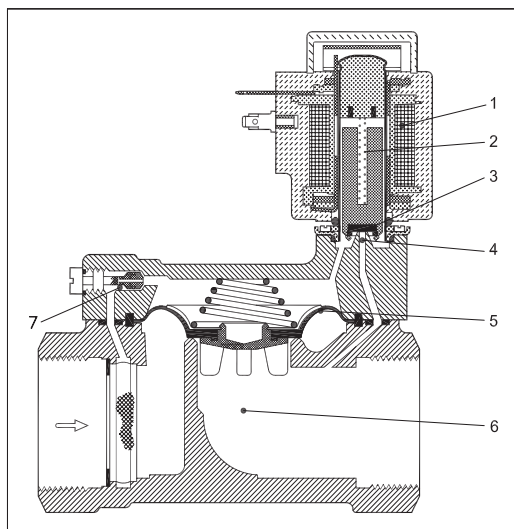

Coil voltage disconnected (closed):

When the voltage is disconnected, the valve plate (3) is pressed down against the pilot orifice (4) by the armature spring (2). The pressure across the diaphragm (5) is built up via the equalising orifice (7). The diaphragm closes the main orifice (6) as soon as the pressure across the diaphragm is equivalent to the inlet pressure. The valve will be closed for as long as the voltage to the coil is disconnected.

Coil voltage connected (open):

When voltage is applied to the coil (1), the pilot orifice (4) is opened. As the pilot orifice is larger than the equalising orifice (7), the pressure across the diaphragm (5) drops and therefore it is lifted clear of the main orifice (6). The valve is now open for unimpeded flow and will be open for as long as the minimum differential pressure across the valve is maintained, and for as long as there is voltage to the coil.

Function, NO

- 1.Armature
- 2.Coil
- 3.Valve plate
- 4.Pilot orifice
- 5.Diaphragm
- 6.Main orifice

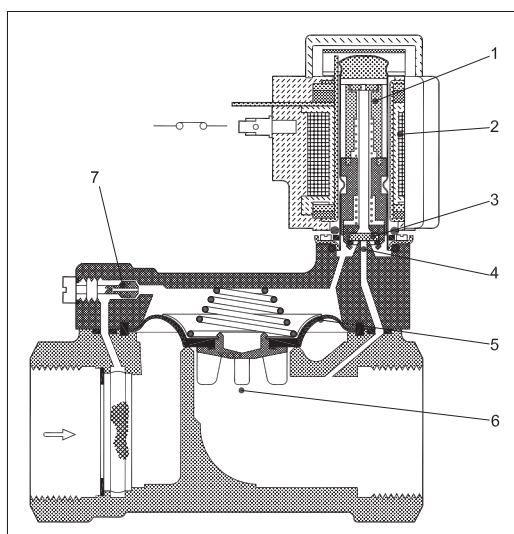

Coil voltage disconnected (open):

When the voltage to the coil (2) is disconnected, the pilot orifice (4) is open. As the pilot orifice is larger than the equalising orifice (7), the pressure across the diaphragm (5) drops and therefore it is lifted clear of the main orifice (6). The valve will be open for as long as the minimum differential pressure across the valve is maintained, and for as long as the voltage to the coil is disconnected.

Coil voltage connected (closed):

When voltage is applied to the coil, the valve plate (3) is pressed down against the pilot orifice (4). The pressure across the diaphragm (5) is built up via the equalising orifice (7). The diaphragm closes the main orifice (6) as soon as the pressure across the diaphragm is equivalent to the inlet pressure. The valve will be closed for as long as there is voltage to the coil.