

PS71 – General Purpose Mini Pressure Switches

► 0.7 to 344 bar (10 to 5000 psi)

These versatile general purpose switches with snap action microswitches can be used in a wide range of hydraulic and pneumatic applications. Their proven piston/diaphragm design offers outstanding accuracy over a very wide pressure range with an outstanding 414 bar proof pressure. Their modular construction allows Gems to offer a large number of standard pressure fittings in two materials as well as numerous electrical ratings and terminations. Users can easily configure this model to meet their needs.

Specifications

Switch	SPST; SPDT
Repeatability	See Table 1
Wetted Parts	
Diaphragm	Nitrile (optional EPDM, Viton® or Neoprene)
Fitting	Zinc-Plated Steel (Optional 316 SS)
Electrical Termination	DIN 43650A IP65; Spade Terminals IP00; Flying Leads IP65; Conduit with Flying Leads IP65; IP option IP66
Proof Pressure	414 bar (6000 psi)
Burst Pressure	600 bar (9000 psi)
Approvals	CE, UL Approved units available
Weight, Approximate	0.15 kg (0.4 lbs.)

Recommended Operating Temperature Limits

Diaphragm Material	Options Selected		
	No option, -10A, -SP or -RD	-RD or -RD and -G	-SP or -10A
Nitrile	-9°C to +85°C (15°F to 185°F)	-9°C to +121°C (15°F to 250°F)	-9°C to +100°C (15°F to 212°F)
Viton®	-18°C to +85°C (0°F to 185°F)	-18°C to +121°C (0°F to 250°F)	-18°C to +100°C (0°F to 212°F)
EPDM	-23°C to +85°C (-10°F to +185°F)	-23°C to +121°C (-10°F to +250°F)	-23°C to +100°C (-10°F to +212°F)
Neoprene	-23°C to +85°C (-10°F to +185°F)	-23°C to +121°C (-10°F to +250°F)	-23°C to +100°C (-10°F to +212°F)

Note: Switches may function below the cold temperature limit but the set points and deadband will increase. Consult factory for details.

Electrical Switch Ratings

Options Selected	AC	DC
No option or -RD	5 amps @ 125/250 Volts	5 amps resistive, 3 amps inductive @ 28 Volts
-G only or -RD with -G	1 amp @ 125 Volts	1 amp resistive, 0.5 amp inductive @ 28 Volts
-10A only or -SP without -G	10.1 amps @ 125/250 Volts	—
-SP with -G	2 amps @ 125/250 Volts	—

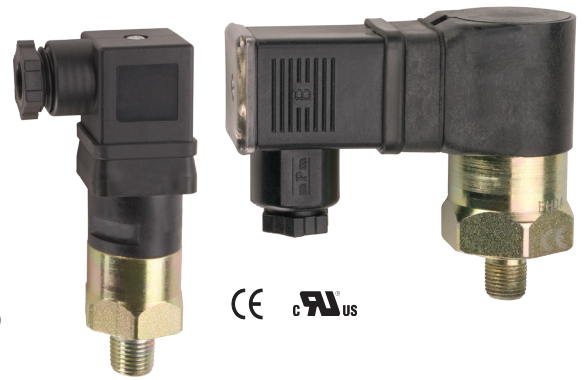

Dimensions

DIN 43650A with Cable Clamp

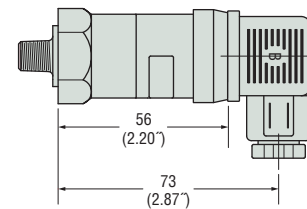

Flying Lead

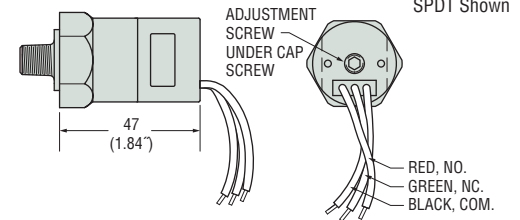

IP66 Option

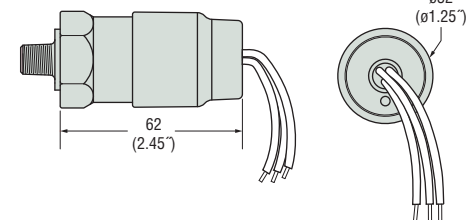

Right Angle DIN 43650A with Cable Clamp

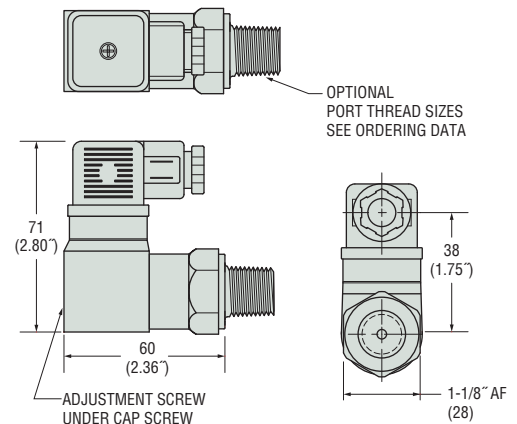

How To Order

Use the **Bold** characters from the chart below to construct a product code. Please reference Notes.

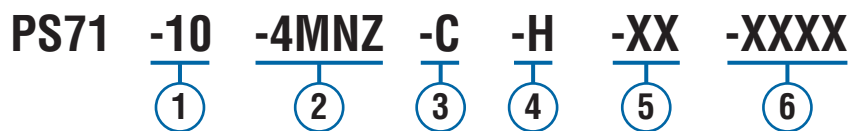

1 Pressure Range Code

Insert Pressure Range Code from Table 1, below.

2 Pressure Fitting¹

12L14 Zinc-Plated Steel

- 2MNZ = 1/8" NPTM
- 4MNZ = 1/4" NPTM
- 8MNZ = 1/2" NPTM
- 2MGZ = 1/8" BSPM (G type)
- 4MGZ = 1/4" BSPM (G type)
- 4MSZ = 7/16"-20 SAE Male
- 6MSZ = 9/16"-18 SAE Male
- M10Z = M10 x 1.0, Straight
- M12Z = M12 x 1.5, Straight
- M14Z = M14 x 1.5, Straight

316 Stainless Steel

- 2MNS = 1/8" NPTM
- 4MNS = 1/4" NPTM
- 2MGS = 1/8" BSPM (G type)
- 4MGS = 1/4" BSPM (G type)

3 Circuit

- A = SPST/N.O.
- B = SPST/N.C.
- C = SPDT

4 Electrical Termination

- SP = Spade Terminals²
- FLXX = Flying Leads³
- FLSXX = Flying Leads w/PVC Shrink Tubing³
- ELXX = 1/2" NPT Male Conduit w/Flying Leads⁴
- CABXX = 18 AWG PVC Cable⁵
 - H = DIN 43650A Male Half Only⁶
 - HR = Right Angle DIN 43650A Male Half Only⁶
 - HC = DIN 43650A 9mm Cable Clamp⁶
 - HCR = Right Angle DIN 43650A 9mm Cable Clamp⁶
 - HN = DIN 43650A with 1/2" Female NPT Conduit⁶
 - HNR = Right Angle DIN 43650A with 1/2" Female NPT Conduit⁶

5 Options⁷

- V = Viton[®] Diaphragm
- E = EPDM Diaphragm
- N = Neoprene Diaphragm
- 10A = 10A @ 125/250 VAC Max. Rating
- G = Gold Contacts (for loads less than 12 mA @ 12 VDC)
- RD = Reduced Differential (25% reduction typical)
- IP = Ingress Protection⁸
- OXY = Oxygen Cleaned⁹
- R = Restrictor (low damping coefficient) Brass
- SR = Spiral Restrictor (high damping coefficient) 300 Series Stainless Steel¹⁰
- WF = Weather Pack Connector, Female
- WM = Weather Pack Connector, Male
- DE = Deutsch Connector, Male, DT04 Series

6 Fixed Set Point (optional)

- A. Specify set point **-FS** (in PSI or BAR, see example)¹¹
 - B. Set Point Actuation
 - R** on Rising Pressure
 - F** on Falling Pressure
- Example: **-FS2BARF** for 2 BAR Falling or **-FS20PSIR** for 20 PSI Rising

Notes:

1. Other fittings available. Consult factory.
2. 20% increase in deadband typical.
3. 457 mm is standard. Specify lead length in millimeters (max. 1,219 mm). e.g. **-FL18** or **-FLS30**.
4. 457 mm is standard. Specify lead length in millimeters (max. 1,219 mm). e.g. **-EL18** or **-EL30**.
5. 914 mm is minimum. Specify cable length in millimeters. e.g. **-CAB36** or **-CAB120**.
6. DIN connectors require **-C** SPDT circuit.
7. Options **-10A**, **-G** or **-RD** cannot be combined.
8. Ingress Protection is available only with **-FL**, **-FLS** or **-CAB** Electrical Termination choices. Ingress Protection requires Fixed Set Point **-FS**.
9. Requires stainless steel housing.
10. **-SR** will result in wider deadbands and slower response time.
11. Set Point must be within Pressure Range selected in Step 1.

Table 1 — Pressure Range Codes

Pressure Range Code	Pressure Range	Accuracy*	Average Deadband**
10	0.7-2.1 bar (10-30 psi)	±0.103 bar (1.5 psi) +2% of setting	0.28 bar (3.5 psi) +11% of setting
20	1.7-5.2 bar (25-75 psi)	±0.172 bar (2.5 psi) +2% of setting	0.28 bar (3.5 psi) +11% of setting
30	4.5-20.7 bar (65-300 psi)	±0.345 bar (5.0 psi) +2% of setting	1.38 bar (20 psig) +11% of setting
40	17.2-69.0 bar (250-1000 psi)	±1.03 bar (15 psi) +2% of setting	3.10 bar (45 psig) +12% of setting
50	69-206.8 bar (1000-3000 psi)	±2.06 bar (30 psi) +3% of setting	4.83 bar (70 psig) +12% of setting
60	172.4-344.7 bar (2500-5000 psi)	±3.45 bar (50 psi) +4% of setting	9.65 bar (140 psi) +13% of setting

* Accuracy and set point of units may change due to the effects of temperature.

** These numbers are for the standard microswitch. With either the **-SP** or **-10A** option, the values are typically 20% greater than those listed. With the **-RD** option, the values will be typically 25% less than those listed. In certain applications deadband can be tailored and controlled to customer specifications. Consult factory for details.