

QS18UPAQ8

Ultrasonic sensor – diffuse mode sensor

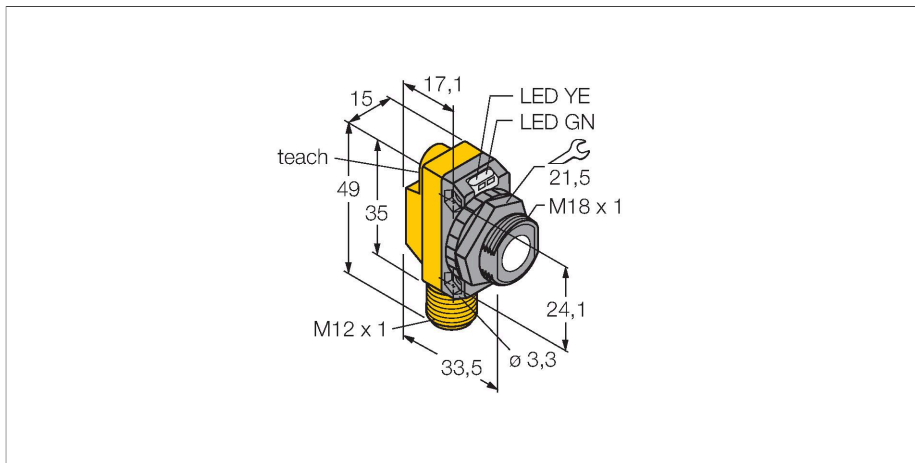

Features

- Operating voltage 12...30 VDC
- Compact design
- Male, M12 x 1
- Switching range adjustable via teach-in
- Adjustable to retroreflective mode

Wiring diagram

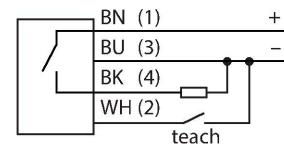

Functional principle

Ultrasonic sensors detect a multitude of objects contactless and wear-free with ultrasonic waves. Regardless of whether the object is transparent or opaque, metallic or non-metallic, liquid, solid or powdery. Even environmental conditions such as spray, dust or rain hardly affect their function.

Technical data

Type	QS18UPAQ8
ID	3073156
Ultrasonic data	
Function	Proximity switch
Range	50...500 mm
Ultrasound frequency	300 kHz
Repeatability	≤ ± 0.7 mm
Temperature drift	≤ 0.1 % of full scale/K
Edge lengths of the nominal actuator	50 mm
Electrical data	
Operating voltage	12...30 VDC
No-load current	≤ 25 mA
Response time typical	< 15 ms
Readiness delay	≤ 300 ms
Output function	NO contact, PNP
Switching frequency	≤ 33 Hz
Hysteresis	≤ 1.4 mm
Short-circuit protection	yes
Reverse polarity protection	Complete
Wire breakage protection	yes
Mechanical data	
Design	Rectangular with thread, QS18U
Radiation direction	straight
Dimensions	33.5 x 15 x 35 mm
Housing material	Plastic, ABS
Transducer material	Plastic, Epoxyd resin and PU foam

Technical data

Electrical connection	Connector, M12 × 1, PVC
Ambient temperature	-20...+60 °C
Relative humidity	100 %
Protection class	IP67
Power-on indication	LED, Green
Switching state	LED, Yellow
Object detected	LED, Green
Tests/approvals	
MTTF	165 years acc. to SN 29500 (Ed. 99) 40 °C
Approvals	CE

Accessories

SMB18A MONTAGEHILFE

3470200

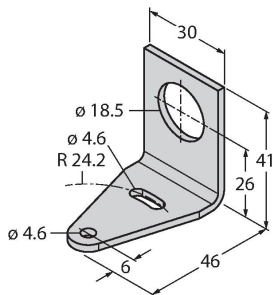

Mounting bracket, stainless steel, for sensors with 18 mm thread

SMB18SF

3052519

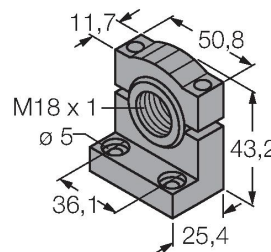

Mounting bracket, PBT black, for sensors with 18 mm thread, rotatable

SMB18FA

3074004

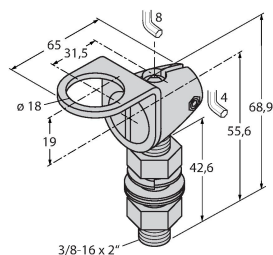

Mounting bracket, material VA 1.4401, for 18 mm thread, 3/8" - 16 x 2" thread

SMB18FM

3079421

mounting bracket, black, M22 x 1.5 mm, male thread, female thread M18 x 1, for sensors with 18 mm thread

SMB18UR

3052517

Mounting bracket, for wall mounting, stainless steel 300, 2-piece, rotatable, 18 mm bore hole, screw set included

SMB18A

3033200

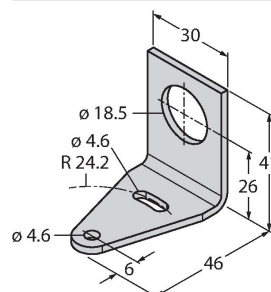

Mounting bracket, rectangular, stainless steel, for sensors with 18 mm thread

SMB18AFAM10

3012558

Mounting bracket, material VA 1.4401, for M10 x 1.5 thread, thread length 18 mm

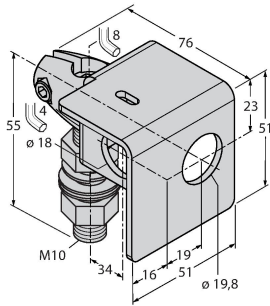

Accessories

Dimension drawing	Type	ID	
	RKC4.4T-2/TEL	6625013	Connection cable, female M12, straight, 4-pin, cable length: 2 m, sheath material: PVC, black; cULus approval; other cable lengths and qualities available, see www.turck.com
	WKC4.4T-2/TEL	6625025	Connection cable, female M12, angled, 4-pin, cable length: 2 m, sheath material: PVC, black; cULus approval; other cable lengths and qualities available, see www.turck.com

Accessories

Dimension drawing	Type	ID	
	UWG18-6.4	3076952	Ultrasonic focussing-adaptor for QS18U and S18U, internal diameter 6.4 mm

Dimension drawing	Type	ID	
	UWG18-5.0	3077342	Ultrasonic focussing-adapter for QS18U and S18U, internal diameter 5.0 mm

