

# Snap-action Microswitches – Standard Metal M9/C9

## M9/C9



Characteristics	<ul style="list-style-type: none"> <li>■ Sealed to IEC IP67 (NEMA Type 13)</li> <li>■ Internal earth (ground) screw provided</li> <li>■ Trident spring mechanism for precise movements and exceptional repeat accuracy</li> <li>■ M20 or ½ inch NPS conduit entry options</li> </ul>
Rating	Up to 250 VAC, 15 A
Dimensions (mm)	76.7 x 45.8 x 26
Actuator	Spring plunger, adjustable roller lever, wobble stick
Approvals	UL, CSA

## Preferred Product Range

Ordering Reference	Actuating Force (N)	Actuating Force (oz)	Sealing	Operating position (mm)	Operating position (in)	Terminal	Circuit	Actuator	Contacts	Electrical rating
M9CTQMSUL	6.7	24.0	IP65	38.6	1.52	Screw/washer	CO	Spring plunger	Silver	Up to 250 VAC, 15 A
M9CTQMSAUL	5.6	20.0	IP65			Screw/washer	CO	Roller lever	Silver	Up to 250 VAC, 15 A
M9CTQMSFUL	1.5	5.5	IP65			Screw/washer	CO	Wobble stick actuator	Silver	Up to 250 VAC, 15 A
C9CTQMSUL	6.7	24.0	IP65	38.6	1.52	Screw/washer	CO	Spring plunger	Silver	Up to 250 VAC, 15 A
C9CTQMSAUL	5.6	20.0	IP65			Screw/washer	CO	Roller lever	Silver	Up to 250 VAC, 15 A
C9CTQMSFUL	1.5	5.5	IP65			Screw/washer	CO	Wobble stick actuator	Silver	Up to 250 VAC, 15 A

# Snap-action Microswitches – Standard Metal M9/C9

## Specifications

Housing	Aluminum alloy
Plunger	Stainless steel (synthetic rubber cowl)
Mechanism	Single pole change-over
Contacts	Silver
Terminals	6-32 UNC screws and cup washers
Temperature range °C	-10°C to +85°C
Mechanical life	10 <sup>5</sup> cycles minimum (impact free actuation)
Protection	IP 67 - NEMA type 6 (enclosure) - providing conduit entry sealed on installation
Mounting	Side mounting
Actuators	Roller lever - mild steel zinc-plated, nylon roller Wobble stick - spring steel wire

Circuit diagram

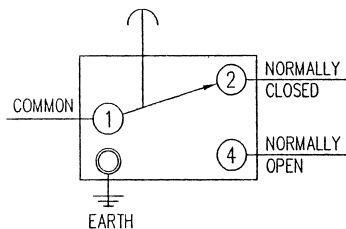

Dimensions  
mm [in]

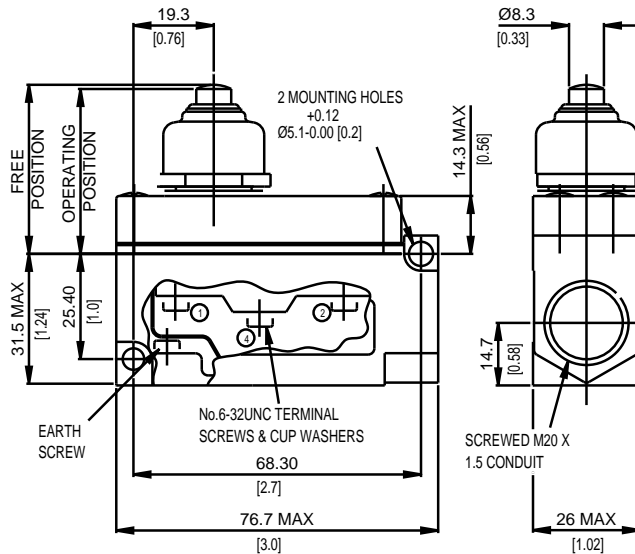

## Recommended Maximum Electrical Ratings

Voltage (max)	Resistive load (A)	Inductive load	Horsepower	Approval
250 VAC	15 (0.75 pf)	15	-	UL 1054/CSA 22.2 No. 55 - 6,000 operations
125 VAC	16 (0.75 pf)	-	-	UL 1054/CSA 22.2 No. 55 - 6,000 operations
0 - 15 VDC	15	-	-	General rating - 50,000 operations
15 - 30 VDC	10	-	-	General rating - 50,000 operations

# Snap-action Microswitches – Standard Metal M9/C9

## Operating Characteristics

Actuator	Reference	Actuating Force		Release Force		Free Position		Operating Position		Movement Differential		Over travel	
		Maximum (N)	Maximum (oz)	Minimum (N)	Minimum (oz)	Maximum (mm)	Maximum (in)	(mm)	(in)	Maximum (mm)	Maximum (in)	Maximum (mm)	Maximum (in)
Spring plunger mm [in]	M9CTQMSUL C9CTQMSUL	6.7	24.0	1.7	6.0	40.5	1.59	38.6 ± 1.2	1.52 ± 0.047	0.08	0.003	4.6	0.18
Roller lever mm [in]	M9CTQMSAUL C9CTQMSAUL	5.6	20.0	1.7	6.0	Pre-travel 10° maximum		Adjustable	0.5°			6.5°	
Wobble stick mm [in]	M9CTQMSFUL C9CTQMSFUL	1.5	5.50					30	1.18			(movement to operate)	

## Ordering Reference – How to Build a Part Number

Type	M9 / C9	
Conduit entry	M9CTQMS C9CTQMS	M20 / 20MM iso thread ½ in NPS thread
Actuators	No digit A F	Spring plunger Rotary lever Wobble stick actuator
Approvals	UL	UL and CSA