



Safety light curtains C2000 Standard

C20E-180303A12, C20S-180103A12



Receiver

Model Name > [C20E-180303A12](#)
Part No. > [1016616](#)



Sender

Model Name > [C20S-180103A12](#)
Part No. > [1016615](#)



At a glance

- Approved 7-segment display for diagnostics
- Robust housing with an industrial design
- Impact and scratch-resistant front screen
- Standardized and a wide range of connection and mounting accessories
- External device monitoring (EDM)
- Internal self-testing function, configurable without PC
- Beam coding for correct system allocation
- Special IP69K variants for wet areas available

Your benefits

- Customer-friendly interfaces and status display facilitate commissioning and maintenance
- High-quality industrial design for reliable and durable continuous operation
- 7-segment display saves time during alignment and diagnostics
- High level of resistance and robust design for high machine availability, even under special ambient conditions
- A multitude of intelligent mounting adapters enables flexible installation
- Integrated additional functions: Reset and EDM for short cable distances to connect with cost-optimized, positively guided relays
- Special variants for the highest requirements on hygiene and tolerance of frequent cleaning



Functions-Sender

Beam coding: ✓
Configuration method: hard wired
Extension connection: -
Safe device communication via EFI/SDL: -

Functions-Receiver

Restart interlock:	-
External device monitoring:	✓
Beam coding:	✓
Muting with:	Flexi Classic, Flexi Soft
Configuration method:	hard wired
Extension connection:	-
Safe device communication via EFI/SDL:	-

Technical Data-Sender

Protective field height:	1,800 mm
Resolution:	30 mm
Scanning range from ... to:	0 m ... 6 m
Housing cross-section:	48 mm x 40 mm
Type:	Type 2 (IEC 61496)
Safety integrity level:	SIL2 (IEC 61508), SILCL2 (IEC 62061)
Category:	category 2 (EN ISO 13849)
Test rate (internal test):	13 /s (EN ISO 13849)
Maximum demand rate:	8 /min (EN ISO 13849) ¹⁾
Performance level:	PL d (EN ISO 13849)
PFHd:	2.2 * 1E-08
TM (Mission Time):	20 a
Enclosure rating:	IP 65 (EN 60529)
Protection class:	III
Ambient operating temperature from ... to:	0 °C ... 55 °C
Vibration resistance (checked to):	5 g (IEC 68-2-6)
Oscillation frequency from ... to:	10 Hz ... 55 Hz
Shock resistance:	10 g, 16 ms (IEC 68-2-29)
Weight:	3.88 kg
Supply voltage typical, from, to:	24 V DC, 19.2 V DC, 28.8 V DC
Maximum power consumption:	6.2 W
Wave length:	950 nm
System connection:	plug M12 x 8
Maximum connection cable cross-section:	0.25 mm ²

¹⁾ Between two demands on a safety-related response of the device, at least 100 internal or external tests must be carried out.

Technical Data-Receiver

Protective field height:	1,800 mm
Resolution:	30 mm
Housing cross-section:	48 mm x 40 mm
Type:	Type 2 (IEC 61496)
Safety integrity level:	SIL2 (IEC 61508), SILCL2 (IEC 62061)
Category:	category 2 (EN ISO 13849)
Test rate (internal test):	13 /s (EN ISO 13849)
Maximum demand rate:	8 /min (EN ISO 13849) ¹⁾
Performance level:	PL d (EN ISO 13849)
PFHd:	2.2 * 1E-08
TM (Mission Time):	20 a
Enclosure rating:	IP 65 (EN 60529)
Protection class:	III

Ambient operating temperature from ... to:	0 °C ... 55 °C
Vibration resistance (checked to):	5 g (IEC 68-2-6)
Oscillation frequency from ... to:	10 Hz ... 55 Hz
Shock resistance:	10 g, 16 ms (IEC 68-2-29)
Weight:	3.88 kg
Response time:	28 ms
Supply voltage typical, from, to:	24 V DC, 19.2 V DC, 28.8 V DC
Maximum power consumption:	8 W
Maximum switching voltage:	min. VS - 2.25 V DC
Maximum switching current:	500 mA
Wave length:	950 nm
System connection:	plug M12 x 8
Maximum connection cable cross-section:	0.25 mm ²

1) Between two demands on a safety-related response of the device, at least 100 internal or external tests must be carried out.

Dimensional drawing

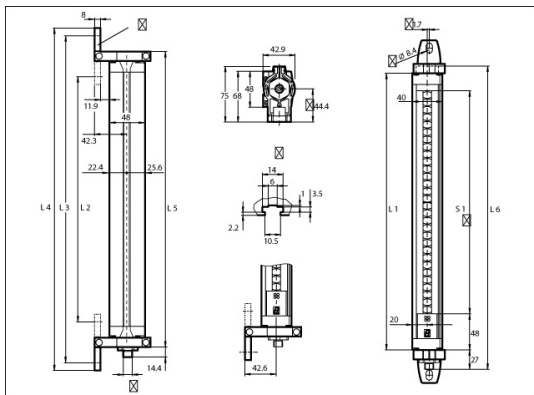

Australia

Phone +61 3 9497 4100
1800 334 802 – tollfree
E-Mail sales@sick.com.au

Belgium/Luxembourg

Phone +32 (0)2 466 55 66
E-Mail info@sick.be

Brasil

Phone +55 11 3215-4900
E-Mail sac@sick.com.br

Canada

Phone +1(952) 941-6780
1 800-325-7425 – tollfree
E-Mail info@sickusa.com

Ceská Republika

Phone +420 2 57 91 18 50
E-Mail sick@sick.cz

China

Phone +852-2763 6966
E-Mail ghk@sick.com.hk

Danmark

Phone +45 45 82 64 00
E-Mail sick@sick.dk

Deutschland

Phone +49 211 5301-301
E-Mail kundenservice@sick.de

España

Phone +34 93 480 31 00
E-Mail info@sick.es

France

Phone +33 1 64 62 35 00
E-Mail info@sick.fr

Great Britain

Phone +44 (0)1727 831121
E-Mail info@sick.co.uk

India

Phone +91-22-4033 8333
E-Mail info@sick-india.com

Israel

Phone +972-4-999-0590
E-Mail info@sick-sensors.com

Italia

Phone +39 02 27 43 41
E-Mail info@sick.it

Japan

Phone +81 (0)3 3358 1341
E-Mail support@sick.jp

Magyarország

Phone +36 1 371 2680
E-Mail office@sick.hu

Nederlands

Phone +31 (0)30 229 25 44
E-Mail info@sick.nl

Norge

Phone +47 67 81 50 00
E-Mail austefjord@sick.no

Österreich

Phone +43 (0)22 36 62 28 8-0
E-Mail office@sick.at

Polska

Phone +48 22 837 40 50
E-Mail info@sick.pl

România

Phone +40 356 171 120
E-Mail office@sick.ro

Russia

Phone +7 495 775 05 30
E-Mail info@sick.ru

Schweiz

Phone +41 41 619 29 39
E-Mail contact@sick.ch

Singapore

Phone +65 6744 3732
E-Mail admin@sicksgp.com.sg

South Africa

Phone +27 11 472 3733
E-Mail info@sickautomation.co.za

South Korea

Phone +82-2 786 6321/4
E-Mail info@sickkorea.net

Slovenija

Phone +386 (0)1-47 69 990
E-Mail office@sick.si

Suomi

Phone +358-9-25 15 800
E-Mail sick@sick.fi

Sverige

Phone +46 10 110 10 00
E-Mail info@sick.se

Taiwan

Phone +886 2 2375-6288
E-Mail sales@sick.com.tw

Türkiye

Phone +90 216 528 50 00
E-Mail info@sick.com.tr

United Arab Emirates

Phone +971 4 8865 878
E-Mail info@sick.ae

USA/México

Phone +1(952) 941-6780
1 800-325-7425 – tollfree
E-Mail info@sickusa.com

More representatives and agencies
at www.sick.com