

SF-2A

SERIES

Small Light Curtain

Type 2



Bringing world-class safety standards even closer to you
Type 2
Standard type



Application of IEC 61496 (Type 2) international standard

The **SF2-A** series conforms to European and North American safety standards. So, they can be used in workplaces throughout the world.



Europe

CE marking based on Machine Directive and EMC Directive has been obtained, so that the sensors can be used in Control Category 2 equipment.

Type 2 based on IEC 61496-1/2, EN 61496-1 and Control Category 2 based on EN 954-1

North America

C-UL US listings (UL 61496-1/2) which are required for use in the United States and Canada have been obtained.

High level of safety achieved

The sensor carries out self-diagnosis when it is turned ON.

The monitoring section (CPU) which is inside the emitter constantly checks the emitting circuit and the control circuit. Furthermore, the receiver also has a monitoring section (CPU) which constantly checks the receiving circuit, control circuit and output circuit, so that a high level of safety is maintained at all times.

Safety design of the SF2-A series

- The sensor switches to the lockout mode when an error occurs, so that the OSSD (control output) and alarm output turn OFF.
- The output circuit is constantly monitored, so that the sensor also locks out if one of the transistors is short-circuited.
- Self-diagnosis using test input allows detailed checking such as overlapping emission (overcurrent error), light emission strength, etc.

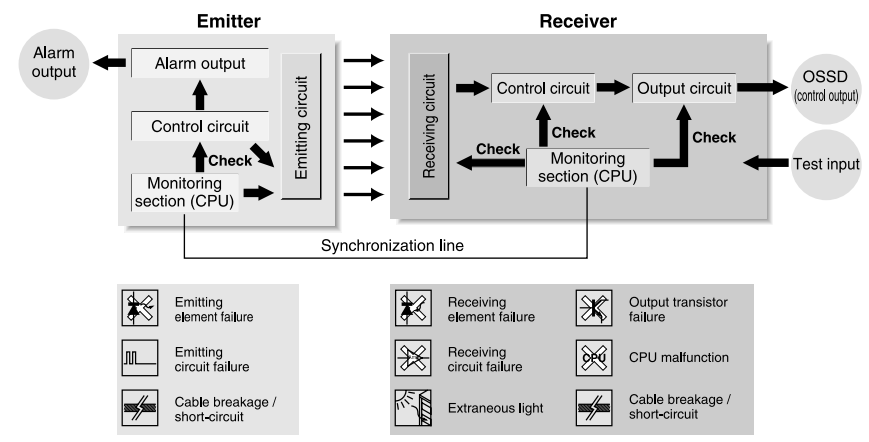

Space-saving design only 28 mm 1.102 in width and 19 mm 0.748 in thickness

With its 28 mm 1.102 in width and 19 mm 0.748 in thickness, it is the smallest in the world* requiring the least installation space in the industry. It can be installed in small spaces incorporated within equipment.

* Data valid as of June 2002 and based on research conducted by SUNX.



Different types for different needs

Sensors are available with beam pitches of 20 mm 0.787 in and 40 mm 1.575 in. The protective height for sensors ranges from 190 mm 7.480 in to 1,950 mm 76.772 in, for both 20 mm 0.787 in and 40 mm 1.575 in beam pitch sensors. NPN·PNP output types are also available for all models. The sensors can be selected from this wide variety to suit your requirement.

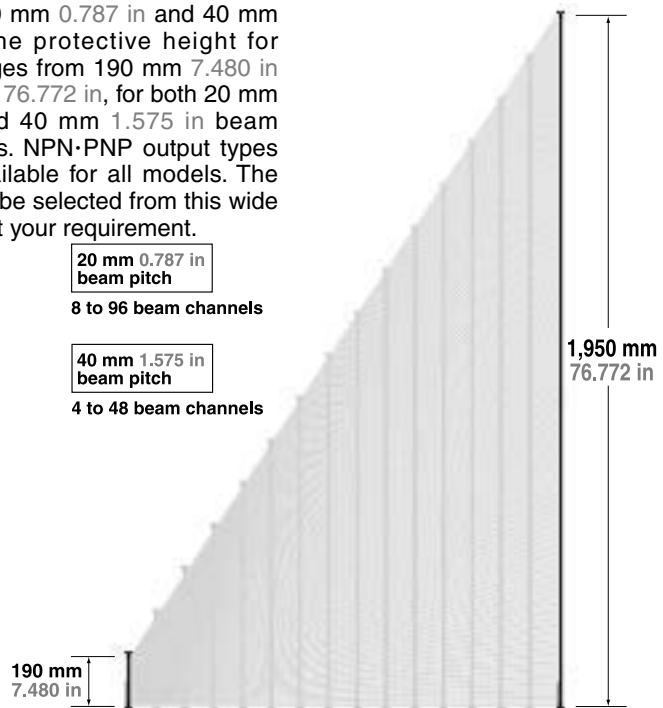

Unaligned beam axes can be seen at a glance

The beam-axis alignment indicators are distributed on the sensors in four sections. As the indicators of the sections whose beams are aligned light up in red, the user can easily verify which beam axes have become aligned. Once all beams have become aligned, the indicators light up in green. Upon beginning alignment, as soon as the bottommost or the topmost beam axis (the standard beam axis) becomes aligned, the corresponding bottommost or topmost alignment indicator light begins blinking red. Therefore, beam axes can be easily aligned by performing the initial beam axis alignment on either the bottommost or the topmost alignment indicator light begins blinking red. Therefore, beam axes can be easily aligned by performing the initial beam axis alignment on either the bottommost or the topmost beam axis, then rotating the light curtain around the axis of this beam. The beam-axis alignment indicators are provided on both the emitter and the receiver, so that you can see at a glance which beams are not aligned.

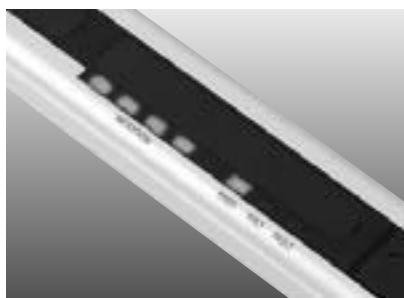

	Conventional unit	SF2-A
When the upper half of all beam axes are aligned	<p>After all beam channels received light, the number of indicators that light up will increase in accordance with the incident light level</p>	<p>Upper two indicators: ON Lower two indicators: OFF</p>
	<p>Even though some beam channels are aligned, the user cannot determine which beam channels are aligned. (Cannot determine which beam axes are not aligned)</p>	<p>Even though beam channels are only partially aligned, the user can determine which beam channels are aligned (Beam axes of two upper blocks are aligned / beam axes of two lower blocks are not aligned)</p>

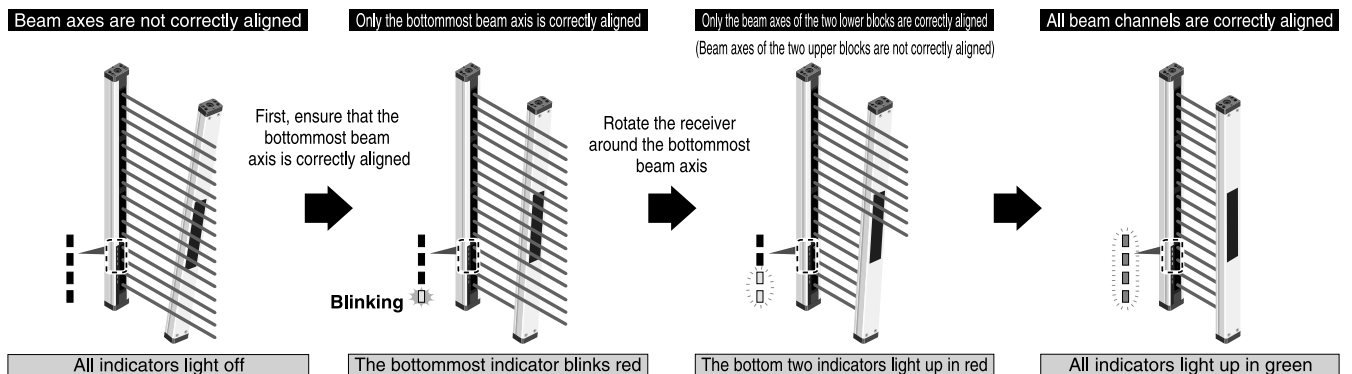

SF2-A

Recognizes extraneous light and prevents malfunctions

This function allows the sensor to recognize and reject interference from instantaneous extraneous light emitted from peripheral equipment, thus preventing malfunctions caused by a variety of sources, including: other sensor beams in the vicinity of the operating sensor, beam spatter, AGV and rotating light sources. By reducing the number of malfunctions caused by extraneous light, detection operations will be interrupted less frequently, resulting in substantial improvements in work efficiency.

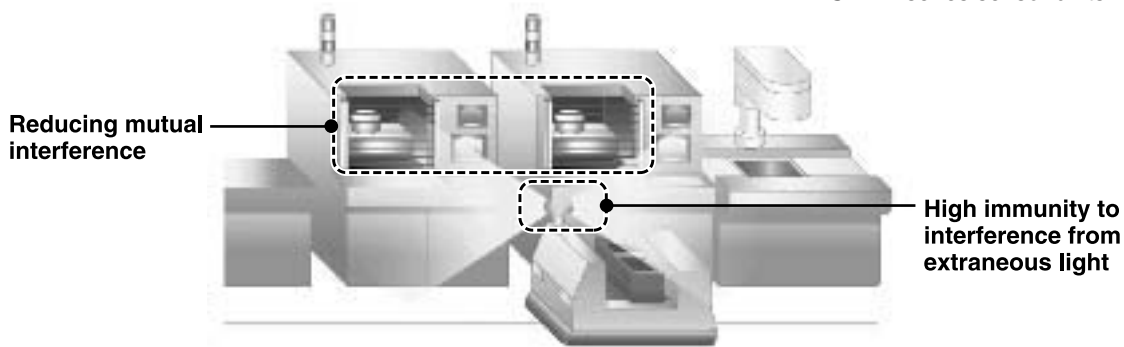

Mutual interference is reduced without the need for interference prevention lines

The ELCA (Extraneous Light Check & Avoid) function enhances the mutual interference prevention function. ELCA decreases interference from extraneous light having a similar frequency as the light used by the SF2-A series, thereby also minimizing mutual interference among nearby SF2-A series sensor units.

Spatter protection for the sensing surface

The spatter protection hood type, now available, protects the sensing surface from welding machine spatter. Moreover, a front protection cover that can be installed within the sensor casing is also available, completely preventing spatter from adhering to the sensing surface. In addition, even though sensed objects may contact the sensor, the sensing surface will be protected. The ELCA function implements all possible measures to prevent malfunctions caused by spatter.

Front protection cover protects the sensing surface

In the event that the SF2-A series is installed in a harsh environment, the use of the front protection cover (FC-SF4A-H□, optional) will protect the sensing surface from damage.

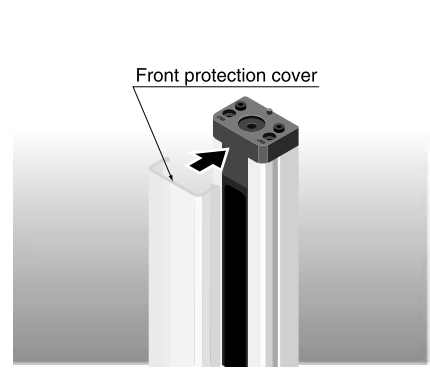
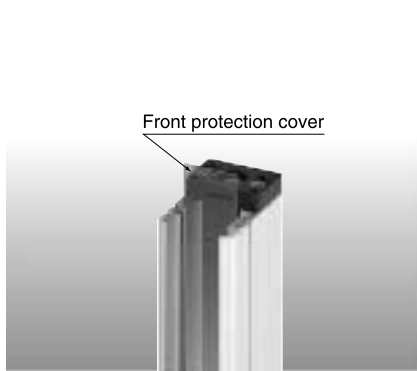

Mounting bracket enables easy beam-axis alignment

The beam-axis alignment is easy since angle adjustment is possible with the enclosed rear mounting bracket (MS-SF2N-1). Alternatively, the side mounting bracket (MS-SF2N-3) is also available as an option.

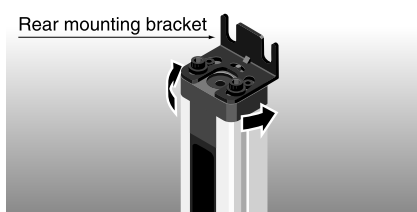

Alignment of beam axes can be accurately performed prior to power-up

By using the SF-LAT-2N laser alignment tool, you can quickly and easily align beam axes. The laser beam spot is easy to see, even when light curtain units are installed far apart. In addition, as the SF-LAT-2N laser alignment tool is battery-operated, beam axes can be aligned before powering up the light curtain itself.

① Align the topmost beam axis

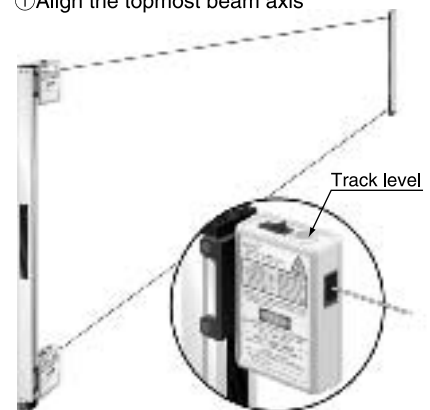

② Align the bottommost beam axis

ORDER GUIDE

Sensors Mating cable is not supplied with the sensor. Please order it separately.

Type	Appearance	Operating range	Model No.		Number of beam channels	Protective height (mm in)	
			NPN output type	PNP output type			
Normal case		0.3 to 7 m 0.984 to 22.966 ft	SF2-AH8	SF2-AH8-PN	8	190	7.480
			SF2-AH12	SF2-AH12-PN	12	270	10.630
			SF2-AH16	SF2-AH16-PN	16	350	13.780
			SF2-AH20	SF2-AH20-PN	20	430	16.929
			SF2-AH24	SF2-AH24-PN	24	510	20.079
			SF2-AH28	SF2-AH28-PN	28	590	23.228
			SF2-AH32	SF2-AH32-PN	32	670	26.378
			SF2-AH36	SF2-AH36-PN	36	750	29.528
			SF2-AH40	SF2-AH40-PN	40	830	32.677
			SF2-AH48	SF2-AH48-PN	48	990	38.976
			SF2-AH56	SF2-AH56-PN	56	1,150	45.276
			SF2-AH64	SF2-AH64-PN	64	1,310	51.575
			SF2-AH72	SF2-AH72-PN	72	1,470	57.874
			SF2-AH80	SF2-AH80-PN	80	1,630	64.173
			SF2-AH88	SF2-AH88-PN	88	1,790	70.472
			SF2-AH96	SF2-AH96-PN	96	1,950	76.772
			SF2-AA4	SF2-AA4-PN	4	190	7.480
			SF2-AA6	SF2-AA6-PN	6	270	10.630
			SF2-AA8	SF2-AA8-PN	8	350	13.780
			SF2-AA10	SF2-AA10-PN	10	430	16.929
			SF2-AA12	SF2-AA12-PN	12	510	20.079
			SF2-AA14	SF2-AA14-PN	14	590	23.228
			SF2-AA16	SF2-AA16-PN	16	670	26.378
			SF2-AA18	SF2-AA18-PN	18	750	29.528
SF2-AA20	SF2-AA20-PN	20	830	32.677			
SF2-AA24	SF2-AA24-PN	24	990	38.976			
SF2-AA28	SF2-AA28-PN	28	1,150	45.276			
SF2-AA32	SF2-AA32-PN	32	1,310	51.575			
SF2-AA36	SF2-AA36-PN	36	1,470	57.874			
SF2-AA40	SF2-AA40-PN	40	1,630	64.173			
SF2-AA44	SF2-AA44-PN	44	1,790	70.472			
SF2-AA48	SF2-AA48-PN	48	1,950	76.772			
With spatter protection hood		0.3 to 7 m 0.984 to 22.966 ft	SF2-AH8-H	SF2-AH8-PN-H	8	190	7.480
			SF2-AH12-H	SF2-AH12-PN-H	12	270	10.630
			SF2-AH16-H	SF2-AH16-PN-H	16	350	13.780
			SF2-AH20-H	SF2-AH20-PN-H	20	430	16.929
			SF2-AH24-H	SF2-AH24-PN-H	24	510	20.079
			SF2-AH28-H	SF2-AH28-PN-H	28	590	23.228
			SF2-AH32-H	SF2-AH32-PN-H	32	670	26.378
			SF2-AH36-H	SF2-AH36-PN-H	36	750	29.528
			SF2-AH40-H	SF2-AH40-PN-H	40	830	32.677
			SF2-AH48-H	SF2-AH48-PN-H	48	990	38.976
			SF2-AH56-H	SF2-AH56-PN-H	56	1,150	45.276
			SF2-AH64-H	SF2-AH64-PN-H	64	1,310	51.575
			SF2-AH72-H	SF2-AH72-PN-H	72	1,470	57.874
			SF2-AH80-H	SF2-AH80-PN-H	80	1,630	64.173
			SF2-AH88-H	SF2-AH88-PN-H	88	1,790	70.472
			SF2-AH96-H	SF2-AH96-PN-H	96	1,950	76.772
			SF2-AA4-H	SF2-AA4-PN-H	4	190	7.480
			SF2-AA6-H	SF2-AA6-PN-H	6	270	10.630
			SF2-AA8-H	SF2-AA8-PN-H	8	350	13.780
			SF2-AA10-H	SF2-AA10-PN-H	10	430	16.929
			SF2-AA12-H	SF2-AA12-PN-H	12	510	20.079
			SF2-AA14-H	SF2-AA14-PN-H	14	590	23.228
			SF2-AA16-H	SF2-AA16-PN-H	16	670	26.378
			SF2-AA18-H	SF2-AA18-PN-H	18	750	29.528
SF2-AA20-H	SF2-AA20-PN-H	20	830	32.677			
SF2-AA24-H	SF2-AA24-PN-H	24	990	38.976			
SF2-AA28-H	SF2-AA28-PN-H	28	1,150	45.276			
SF2-AA32-H	SF2-AA32-PN-H	32	1,310	51.575			
SF2-AA36-H	SF2-AA36-PN-H	36	1,470	57.874			
SF2-AA40-H	SF2-AA40-PN-H	40	1,630	64.173			
SF2-AA44-H	SF2-AA44-PN-H	44	1,790	70.472			
SF2-AA48-H	SF2-AA48-PN-H	48	1,950	76.772			

SF2-A

ORDER GUIDE

Mating cables Mating cable is not supplied with the sensor. Please order it separately.

Designation	Appearance	Model No.	Description
Cable with connector on one end		SF2N-CC3	Length: 3 m 9.843 ft Weight: 400 g approx. (two cables) These cables are used for wiring. 7-core (6-core for emitter) shielded cable with connector on one end, two cables per set
		SF2N-CC7	Length: 7 m 22.966 ft Weight: 870 g approx. (two cables) Cable outer diameter: ϕ 6 mm ϕ 0.236 in Connector outer diameter: ϕ 14 mm ϕ 0.551 in max. Cable color: Gray (for emitter)
		SF2N-CC10	Length: 10 m 32.808 ft Weight: 1,200 g approx. (two cables) Gray with black line (for receiver)
Cable with connector on both ends		SF2N-CCJ10	Length: 10 m 32.808 ft Weight: 1,200 g approx. (two cables) This cable is used for cable extension. Shielded cable with connector on both ends, two cables per set Cable outer diameter: ϕ 6 mm ϕ 0.236 in Connector outer diameter: ϕ 14 mm ϕ 0.551 in max. Cable color: Gray (for emitter), Gray with black line (for receiver)

Spare parts (Accessories for sensor)

Designation	Model No.	Description
Rear mounting bracket	MS-SF2N-1	Used to mount the sensor on the rear surface (1 set for emitter and receiver)
U-shaped rear mounting intermediate supporting bracket (Note)	MS-SF2N-2	For SF2-A□(-PN) Used to hold the sensor at the intermediate position for protection against vibration (for rear surface mounting) (1 set for emitter and receiver)
	MS-SF4A-H2	For SF2-A□(-PN)-H
L-shaped intermediate supporting bracket (Note)	MS-SF2N-L	Used to install the intermediate supporting bracket on the wall side, etc. (1 set for emitter and receiver)
Test rod	SF2-AH-TR	Used for standard sensing to detect the smallest objects (ϕ 30 mm ϕ 1.181 in), with 20 mm 0.787 in beam pitch

Note: The number of sets required varies depending on the product.

Rear mounting bracket

- **MS-SF2N-1**

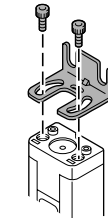

Four bracket set
Eight M3 (length 5 mm 0.197 in) hexagon-socket-head bolts are attached.

U-shaped rear mounting intermediate supporting bracket

- **MS-SF2N-2**
- **MS-SF4A-H2**
- **MS-SF2N-L**

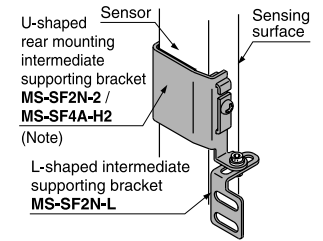

Note: The above figure is only applicable to the **MS-SF2N-2**. The **MS-SF4A-H2** has a different shape.

- **MS-SF2N-2 / MS-SF4A-H2**
Set of 2 pcs. each of U-shaped rear supporting bracket and retaining plate

- **MS-SF2N-L**
Two L-shaped bracket set
Two M3 (length 10 mm 0.394 in) pan head screws, two M4 (length 10 mm 0.394 in) hexagon-socket-head bolts and two nuts are attached.

OPTIONS

Designation	Applicable beam channels	20 mm 0.787 in beam pitch	8 beam channels	12 beam channels	16 beam channels	20 beam channels	24 beam channels	28 beam channels	32 beam channels	36 beam channels	40 beam channels	48 beam channels	56 beam channels	64 beam channels	72 beam channels	80 beam channels	88 beam channels	96 beam channels
		40 mm 1.575 in beam pitch	4 beam channels	6 beam channels	8 beam channels	10 beam channels	12 beam channels	14 beam channels	16 beam channels	18 beam channels	20 beam channels	24 beam channels	28 beam channels	32 beam channels	36 beam channels	40 beam channels	44 beam channels	48 beam channels
Front protection cover	For SF2-A□(-PN)	Model No.	FC-SF4A-H8	FC-SF4A-H12	FC-SF4A-H16	FC-SF4A-H20	FC-SF4A-H24	FC-SF4A-H28	FC-SF4A-H32	FC-SF4A-H36	FC-SF4A-H40	FC-SF4A-H48	FC-SF4A-H56	FC-SF4A-H64	FC-SF4A-H72	FC-SF4A-H80	FC-SF4A-H88	FC-SF4A-H96
	For SF2-A□(-PN)-H	Model No.	FC-SF4A-H8-H	FC-SF4A-H12-H	FC-SF4A-H16-H	FC-SF4A-H20-H	FC-SF4A-H24-H	FC-SF4A-H28-H	FC-SF4A-H32-H	FC-SF4A-H36-H	FC-SF4A-H40-H	FC-SF4A-H48-H	FC-SF4A-H56-H	FC-SF4A-H64-H	FC-SF4A-H72-H	FC-SF4A-H80-H	FC-SF4A-H88-H	FC-SF4A-H96-H
Slit mask	For SF2-A□(-PN)	Model No.	OS-SF4A-H8	OS-SF4A-H12	OS-SF4A-H16	OS-SF4A-H20	OS-SF4A-H24	OS-SF4A-H28	OS-SF4A-H32	OS-SF4A-H36	OS-SF4A-H40	OS-SF4A-H48	OS-SF4A-H56	OS-SF4A-H64	OS-SF4A-H72	OS-SF4A-H80	OS-SF4A-H88	OS-SF4A-H96
	For SF2-A□(-PN)-H	Model No.	OS-SF4A-H8-H	OS-SF4A-H12-H	OS-SF4A-H16-H	OS-SF4A-H20-H	OS-SF4A-H24-H	OS-SF4A-H28-H	OS-SF4A-H32-H	OS-SF4A-H36-H	OS-SF4A-H40-H	OS-SF4A-H48-H	OS-SF4A-H56-H	OS-SF4A-H64-H	OS-SF4A-H72-H	OS-SF4A-H80-H	OS-SF4A-H88-H	OS-SF4A-H96-H

Note: The model Nos. given above denote a single unit, not a pair of units. 2 pcs. (2 sets) are required to mount the emitter / receiver.

Front protection cover

- **FC-SF4A-H□**

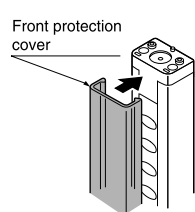

- **FC-SF4A-H□-H**

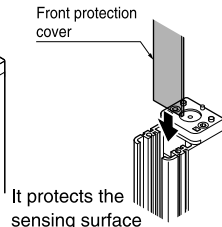

Slit mask

- **OS-SF4A-H□**

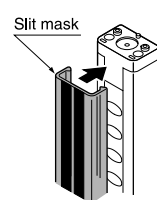

- **OS-SF4A-H□-H**

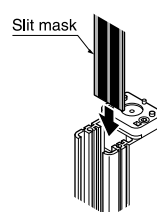

The slit mask restrains the amount of beam emitted or received and hence reduces the interference between neighboring sensors. It is also used in cases when the beam intensity is too strong penetrating through the sensing object. However, the operating range reduces when the slit mask is used.

Operating range

- <**OS-SF4A-H□ / OS-SF4A-H□-H**>
- Slit on the emitter side: 2.6 m 8.530 ft
- Slit on the receiver side: 2.6 m 8.530 ft
- Slit on both sides: 1.2 m 3.937 ft

ORDER GUIDE

Designation	Model No.	Description
Large display unit for light curtain	SF-IND-2	<p>With the large display unit put on the light curtain, the operation is easily observable from various directions.</p> <p>Specifications</p> <ul style="list-style-type: none"> • Supply voltage: 24 V DC \pm 15 % • Current consumption: 12 mA or less • Indicators: Orange LED (8 pcs.used) [Light up when external contact is ON] • Ambient temperature: -10 to $+55$ °C $+14$ to $+131$ °F (No dew condensation or icing allowed) • Material: POM (Case) Polycarbonate (Cover) Cold rolled carbon steel (SPCC)(Bracket) • Cable: 0.3 mm² 2-core cable, 3 m 9.843 ft long • Weight: 70 g approx. (including bracket) <p>I/O circuit diagrams</p> <p><With NPN output type></p> <p><With PNP output type></p>
		<p>Side mounting bracket</p> <p>MS-SF2N-3</p> <p>Used for side-mounting of sensors (four bracket set for emitter and receiver)</p>
U-shaped side mounting intermediate supporting bracket (Note 1)	MS-SF2N-4 MS-SF4A-H4	<p>MS-SF2N-4 For SF2-A□(-PN)</p> <p>MS-SF4A-H4 For SF2-A□(-PN)-H</p> <p>Used to hold the sensor at the intermediate position for protection against vibration (for side mounting) (1 set for emitter and receiver)</p>
Center sensor mounting bracket (Note 2)	MS-SF2N-5	Used for one-point rear mounting Convenient for mounting on an aluminum frame (four bracket set for emitter and receiver)
Test rod	SF2-AA-TR	Used for standard sensing to detect the smallest objects (ϕ 50 mm ϕ 1.969 in), with 40 mm 1.575 in beam pitch
Safety relay unit (For PNP output type light curtain) (Note 3)	SF-AC	<p>Relay unit for PNP output type</p> <ul style="list-style-type: none"> • Complies with Control Categories up to 4 based on EN 954-1 (Categories up to 2 when it is combines with the SF2-A series) <p>Enabling path \times 3</p>
Laser alignment tool (Note 4)	SF-LAT-2N	Easy to align the beam axis with the visible laser beam

- Notes: 1) The number of sets required varies depending on the product.
 2) Multiple beam channel sensors requiring the intermediate supporting bracket (20 mm 0.787 in beam pitch type: 36 beam channels or more, 40 mm 1.575 in beam pitch type: 18 beam channels or more) cannot be mounted on an aluminum frame with the center sensor mounting bracket.
 3) Refer to p.436~ for further details about the SF-AC.
 4) Refer to 'SF4-AH' series for further details about the laser alignment tool.

Large display unit for light curtain

• SF-IND-2

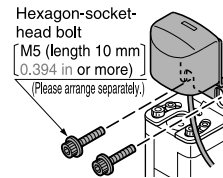

Attaches to upper edge of light curtain. Tighten together the mounting bracket provided with the area sensor and the mounting bracket of SF-IND-2.

Center sensor mounting bracket

• MS-SF2N-5

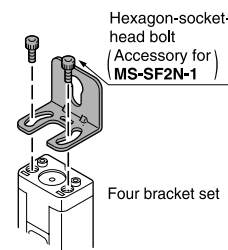

Safety relay unit (For PNP output type) light curtain

• SF-AC

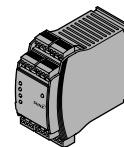

Laser alignment tool

• SF-LAT-2N

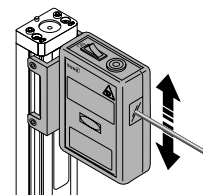

Side mounting bracket

• MS-SF2N-3

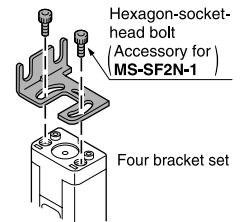

U-shaped side mounting intermediate supporting bracket

• MS-SF2N-4
• MS-SF4A-H4

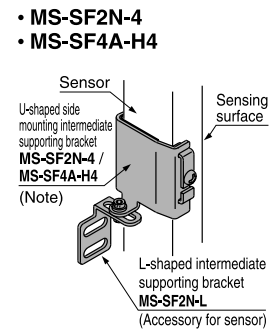

Note: The above figure is only applicable to the MS-SF2N-4.

The MS-SF4A-H4 has a different shape.

- MS-SF2N-4 / MS-SF4A-H4
Set of 2 pcs. each of U-shaped side supporting bracket and retaining plate
- MS-SF2N-L (Accessory for sensor)
Two L-shaped bracket set
Two M3 (length 10 mm 0.394 in) pan head screws, two M4 (length 10 mm 0.394 in) hexagon-socket-head bolts and two nuts are attached.

SF2-A

SPECIFICATIONS

Individual specifications

SF2-AH□(-H)

Item	Type		20 mm 0.787 in beam pitch							
	Model No.	NPN output PNP output	SF2-AH8(-H)	SF2-AH12(-H)	SF2-AH16(-H)	SF2-AH20(-H)	SF2-AH24(-H)	SF2-AH28(-H)	SF2-AH32(-H)	SF2-AH36(-H)
No. of beam channels			8	12	16	20	24	28	32	36
Beam pitch			20 mm 0.787 in							
Protective height			190 mm 7.480 in	270 mm 10.630 in	350 mm 13.780 in	430 mm 16.929 in	510 mm 20.079 in	590 mm 23.228 in	670 mm 26.378 in	750 mm 29.528 in
Current consumption			Emitter: 45 mA or less, Receiver: 60 mA or less				Emitter: 55 mA or less, Receiver: 70 mA or less			
Weight (Total of emitter and receiver)	SF2-AH□(-PN)		350 g approx.	430 g approx.	520 g approx.	610 g approx.	700 g approx.	780 g approx.	880 g approx.	960 g approx.
	SF2-AH□(-PN)-H		420 g approx.	560 g approx.	700 g approx.	830 g approx.	970 g approx.	1,100 g approx.	1,200 g approx.	1,400 g approx.

Item	Type		20 mm 0.787 in beam pitch							
	Model No.	NPN output PNP output	SF2-AH40(-H)	SF2-AH48(-H)	SF2-AH56(-H)	SF2-AH64(-H)	SF2-AH72(-H)	SF2-AH80(-H)	SF2-AH88(-H)	SF2-AH96(-H)
No. of beam channels			40	48	56	64	72	80	88	96
Beam pitch			20 mm 0.787 in							
Protective height			830 mm 32.677 in	990 mm 38.976 in	1,150 mm 45.276 in	1,310 mm 51.575 in	1,470 mm 57.874 in	1,630 mm 64.173 in	1,790 mm 70.472 in	1,950 mm 76.772 in
Current consumption			Emitter: 60 mA or less, Receiver: 80 mA or less			Emitter: 65 mA or less, Receiver: 95 mA or less		Emitter: 70 mA or less, Receiver: 110 mA or less		Emitter: 80 mA or less, Receiver: 120 mA or less
Weight (Total of emitter and receiver)	SF2-AH□(-PN)		1,100 g approx.	1,200 g approx.	1,400 g approx.	1,600 g approx.	1,800 g approx.	1,900 g approx.	2,100 g approx.	2,300 g approx.
	SF2-AH□(-PN)-H		1,500 g approx.	1,800 g approx.	2,100 g approx.	2,300 g approx.	2,600 g approx.	2,900 g approx.	3,200 g approx.	3,400 g approx.

SF2-AA□(-H)

Item	Type		40 mm 1.575 in beam pitch							
	Model No.	NPN output PNP output	SF2-AA4(-H)	SF2-AA6(-H)	SF2-AA8(-H)	SF2-AA10(-H)	SF2-AA12(-H)	SF2-AA14(-H)	SF2-AA16(-H)	SF2-AA18(-H)
No. of beam channels			4	6	8	10	12	14	16	18
Beam pitch			40 mm 1.575 in							
Protective height			190 mm 7.480 in	270 mm 10.630 in	350 mm 13.780 in	430 mm 16.929 in	510 mm 20.079 in	590 mm 23.228 in	670 mm 26.378 in	750 mm 29.528 in
Current consumption			Emitter: 40 mA or less, Receiver: 50 mA or less				Emitter: 45 mA or less, Receiver: 60 mA or less			
Weight (Total of emitter and receiver)	SF2-AA□(-PN)		350 g approx.	430 g approx.	520 g approx.	610 g approx.	700 g approx.	780 g approx.	880 g approx.	960 g approx.
	SF2-AA□(-PN)-H		420 g approx.	560 g approx.	700 g approx.	830 g approx.	970 g approx.	1,100 g approx.	1,200 g approx.	1,400 g approx.

Item	Type		40 mm 1.575 in beam pitch							
	Model No.	NPN output PNP output	SF2-AA20(-H)	SF2-AA24(-H)	SF2-AA28(-H)	SF2-AA32(-H)	SF2-AA36(-H)	SF2-AA40(-H)	SF2-AA44(-H)	SF2-AA48(-H)
No. of beam channels			20	24	28	32	36	40	44	48
Beam pitch			40 mm 1.575 in							
Protective height			830 mm 32.677 in	990 mm 38.976 in	1,150 mm 45.276 in	1,310 mm 51.575 in	1,470 mm 57.874 in	1,630 mm 64.173 in	1,790 mm 70.472 in	1,950 mm 76.772 in
Current consumption			Emitter: 50 mA or less, Receiver: 65 mA or less		Emitter: 50 mA or less, Receiver: 70 mA or less		Emitter: 55 mA or less, Receiver: 75 mA or less		Emitter: 60 mA or less, Receiver: 80 mA or less	
Weight (Total of emitter and receiver)	SF2-AA□(-PN)		1,100 g approx.	1,200 g approx.	1,400 g approx.	1,600 g approx.	1,800 g approx.	1,900 g approx.	2,100 g approx.	2,300 g approx.
	SF2-AA□(-PN)-H		1,500 g approx.	1,800 g approx.	2,100 g approx.	2,300 g approx.	2,600 g approx.	2,900 g approx.	3,200 g approx.	3,400 g approx.

SPECIFICATIONS

Common specifications

Item	Model No.	20 mm 0.787 in beam pitch		40 mm 1.575 in beam pitch	
		NPN output	PNP output	NPN output	PNP output
Applicable standards		Category 2 based on EN 954-1 (Type 2 based on IEC 61496-1/2)			
Operating range		0.3 to 7 m 0.984 to 22.966 ft			
Detection capability		φ30 mm φ1.181 in opaque object		φ50 mm φ1.969 in opaque object	
Effective aperture angle		± 5 ° or less for a operating range exceeding 3 m 9.843 ft (conforming to IEC 61496-2 / UL 61496-2)			
Supply voltage		24 V DC ± 15 % Ripple P-P 10 % or less			
Control output (OSSD)		<NPN output type> NPN open-collector transistor • Maximum sink current: 200 mA • Applied voltage: Same as supply voltage (between control output and 0 V) • Residual voltage: 2.0 V or less (at 200 mA sink current)		<PNP output type> PNP open-collector transistor • Maximum source current: 200 mA • Applied voltage: Same as supply voltage (between control output and + V) • Residual voltage: 2.5 V or less (at 200 mA source current)	
	Utilization category	DC-12 or DC-13			
	Operation mode	ON when all beam channels are received, OFF when one or more beam channels are interrupted (OFF also in case of any malfunction in the sensor or the synchronization signal)			
	Protection circuit	Incorporated			
Response time		OFF response: 15 ms or less, ON response: 40 to 60 ms or less (under stable light received condition)			
Alarm output		<NPN output type> NPN open-collector transistor • Maximum sink current: 60 mA • Applied voltage: Same as supply voltage (between alarm output and 0 V) • Residual voltage: 2.0 V or less (at 60 mA sink current)		<PNP output type> PNP open-collector transistor • Maximum source current: 60 mA • Applied voltage: Same as supply voltage (between alarm output and + V) • Residual voltage: 2.5 V or less (at 60 mA source current)	
	Operation mode	Normal operation: Alarm output ON, Failure resulting in emission halt, or when test input is applied: Alarm output OFF			
	Protection circuit	Incorporated			
Indicators	Emitter	Beam-axis alignment indicators: 2-color (Red / Green) LED × 4 (lights up in red when the each beam channel receives light, blinks in red when the topmost or bottommost beam channel receives light, light up in green when all beam channels receive light) Operation indicator (Note 1): 2-color (Red / Green) LED [lights up in red when control output (OSSD) is OFF, lights up in green when control output (OSSD) is ON] Emission halt indicator: Orange LED (lights up when emission halts) Fault indicator: Yellow LED (lights up or blinks if a fault occurs in the sensor)			
	Receiver	Beam-axis alignment indicators: 2-color (Red / Green) LED × 4 (lights up in red when the each beam channel receives light, blinks in red when the topmost or bottommost beam channel receives light, light up in green when all beam channels receive light) OSSD indicator: 2-color (Red / Green) LED [lights up in red when control output (OSSD) is OFF, light up in green when control output (OSSD) is ON] Unstable incident beam indicator: Orange LED (lights up when light received is unstable) Fault indicator: Yellow LED (lights up or blinks if a fault occurs in the sensor)			
Test input (emission halt) function		Incorporated			
Environmental resistance	Pollution degree	3 (Industrial environment)			
	Degree of protection	IP65 (IEC)			
	Ambient temperature / Ambient humidity	- 10 to + 55 °C + 14 to + 131 °F (No dew condensation or icing allowed), Storage: - 25 to + 70 °C - 13 to + 158 °F / 30 to 85 % RH, Storage: 30 to 95 % RH			
	Ambient illuminance	Sunlight: 20,000 lx at the light-receiving face, Incandescent light: 3,500 lx at the light-receiving face			
	Dielectric strength voltage / Insulation resistance	1,000 V AC for one min. between all supply terminals connected together and enclosure (Note 2) / 20 MΩ, or more, with 500 V DC megger between all supply terminals connected together and enclosure (Note 2)			
	Vibration resistance / Shock resistance	10 to 55 Hz frequency, 0.75 mm 0.030 in amplitude in X, Y and Z directions for two hours each / 300 m/s ² acceleration (30 G approx.) in X, Y and Z directions for three times each			
Emitting element		Infrared LED (Peak emission wavelength: 870 nm 0.034 mil)			
Material		Enclosure: Aluminium, Resin case: ABS, Lens: Polycarbonate, Cap: PBT			
Cable		Emitter: 6-core (0.3 mm ² × 4-core, 0.2 mm ² × 2-core) shielded cable, 0.5 m 1.640 ft long, with a connector at the end Receiver: 7-core (0.3 mm ² × 5-core, 0.2 mm ² × 2-core) shielded cable, 0.5 m 1.640 ft long, with a connector at the end			
Cable extension		Extension up to total 20.5 m 67.257 ft is possible, for both emitter and receiver, with optional mating cables			
Accessories		MS-SF2N-1 (Rear mounting bracket): 1 set for emitter and receiver MS-SF2N-2 (U-shaped rear mounting intermediate supporting bracket, MS-SF4A-H2 for '-H' type): (Note 3) MS-SF2N-L (L-shaped intermediate supporting bracket): (Note 3) SF2-AH-TR (Test rod): 1 pc. [SF2-AH□(-PN)(-H) only]			

Notes: 1) Since the color of operation indicator changes according to the ON / OFF state of control output (OSSD), the operation indicator is marked as 'OSSD' on the sensor.

2) Surge absorber is connected between the main body enclosure and the supply terminals to avoid faulty operation due to surge. For this reason, the values for dielectric strength voltage and insulation resistance are given for the condition when the surge absorber has been removed.

3) U-shaped rear mounting intermediate supporting bracket (**MS-SF2N-2** or **MS-SF4A-H2**) and L-shaped intermediate supporting bracket (**MS-SF2N-L**) are attached with the following sensors. The number of attached U-shaped rear mounting intermediate supporting bracket and L-shaped intermediate supporting bracket are different depending on the sensor as follows.

SF2-AH36(-PN)(-H), **SF2-AH40(-PN)(-H)**, **SF2-AA18(-PN)(-H)**, **SF2-AA20(-PN)(-H)**: 1 set

SF2-AH48(-PN)(-H), **SF2-AA24(-PN)(-H)**: 2 sets

SF2-AH56(-PN)(-H), **SF2-AH64(-PN)(-H)**, **SF2-AH72(-PN)(-H)**, **SF2-AA28(-PN)(-H)**, **SF2-AA32(-PN)(-H)**, **SF2-AA36(-PN)(-H)**: 3 sets

SF2-AH80(-PN)(-H), **SF2-AA40(-PN)(-H)**: 4 sets

SF2-AH88(-PN)(-H), **SF2-AH96(-PN)(-H)**, **SF2-AA44(-PN)(-H)**, **SF2-AA48(-PN)(-H)**: 5 sets

SF2-A

I/O CIRCUIT AND WIRING DIAGRAMS

NPN output type

I/O circuit diagram

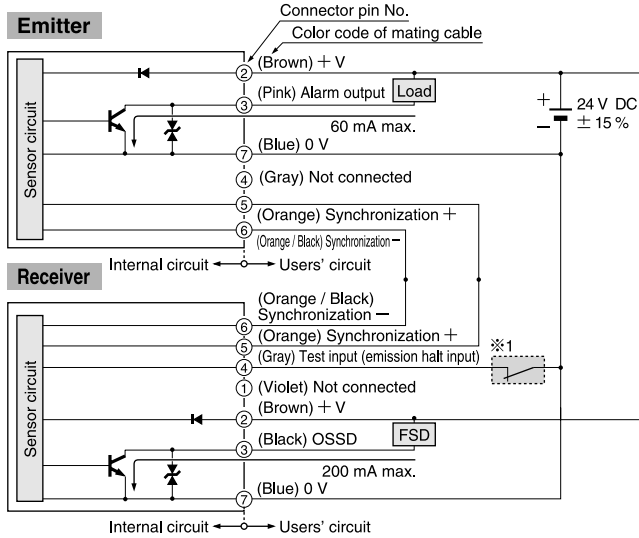

Note: Unused wires must be insulated to ensure that they do not come into contact with wires already in use.

CAUTION

Use a safety relay unit or an equivalent safety control circuit for FSD.

※1

Non-voltage contact or NPN open-collector transistor

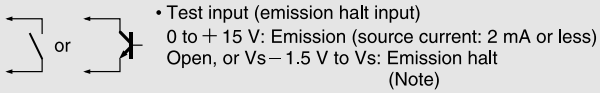

Wiring diagram

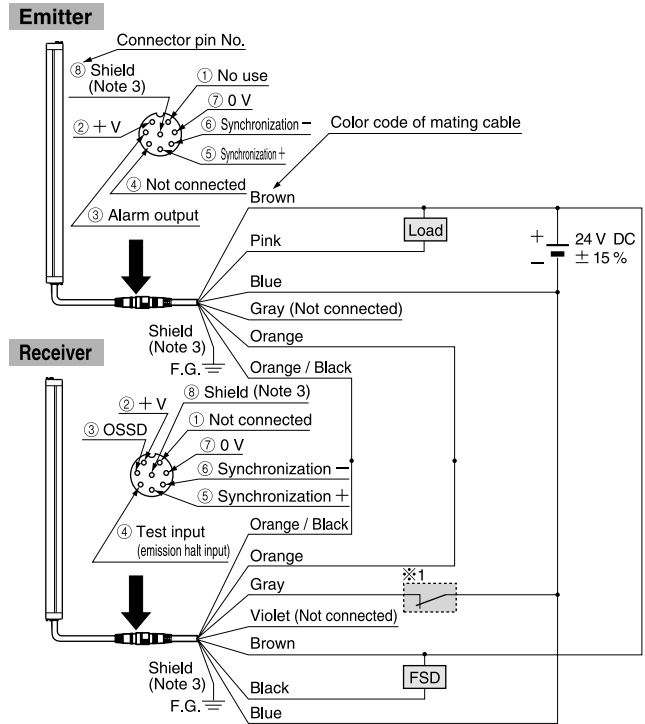

- Notes:
- 1) Unused wires must be insulated to ensure that they do not come into contact with wires already in use.
 - 2) Conductor cross-section area of lead wire of mating cable is 0.2 mm^2 (synchronization wire) and 0.3 mm^2 (exclude synchronization wire).
 - 3) Be sure to connect the shield wire to the frame ground (F.G.).

SF2-A

PRECAUTIONS FOR PROPER USE

Part description and function

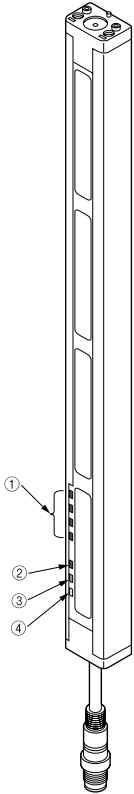

	Description	Function
Emitter	① Beam-axis alignment indicators [RECEPTION] (Red / Green LED)	Top : Blinks in red when the topmost beam channel receives light, lights up in red when sensor top receives light. Upper middle : Lights up in red when sensor upper middle receives light. Lower middle : Lights up in red when sensor lower middle receives light. Bottom : Blinks in red when the bottommost beam channel receives light, lights up in red when sensor bottom receives light. Lights up in green when all beam channels (top, upper middle, lower middle and bottom) receive light.
	② Operation indicator [OSSD] (Note 1) (Red / Green LED)	Lights up in red when control output (OSSD) is OFF, lights up in green when control output (OSSD) is ON.
	③ Emission halt indicator [HALT] (Orange LED)	Lights up when emission halts.
	④ Fault indicator [FAULT] (Yellow LED)	Lights up or blinks when a fault occurs in the sensor. (Note 2) Lights up: Malfunction of internal circuit Blinks: Effects from noise, power supply or malfunction of internal circuit
Receiver	① Beam-axis alignment indicators [RECEPTION] (Red / Green LED)	Top : Blinks in red when the topmost beam channel receives light, lights up in red when sensor top receives light. Upper middle : Lights up in red when sensor upper middle receives light. Lower middle : Lights up in red when sensor lower middle receives light. Bottom : Blinks in red when the bottommost beam channel receives light, lights up in red when sensor bottom receives light. Lights up in green when all beam channels (top, upper middle, lower middle and bottom) receive light.
	② OSSD indicator [OSSD] (Red / Green LED)	Lights up in red when control output (OSSD) is OFF, lights up in green when control output (OSSD) is ON.
	③ Unstable incident beam indicator [STB.] (Orange LED)	Lights up when light received is unstable.
	④ Fault indicator [FAULT] (Yellow LED)	Lights up or blinks when a fault occurs in the sensor. (Note 2) Lights up: Fault occurs in OSSD circuit. (please contact our office.) 1 blink: Received extraneous light error 2 blinks: Effects from noise, power supply or malfunction of internal circuitry

Notes: 1) Since the color of the operation indicator changes according to the ON / OFF state of 'OSSD', the operation indicator is marked as OSSD on the sensor.

2) The blinking cycle of the fault indicator is illustrated below. The number of blinks indicate what kind of fault has occurred. There is an interval of approx. 1 sec. between blinking.

Blinking cycle of fault indicator

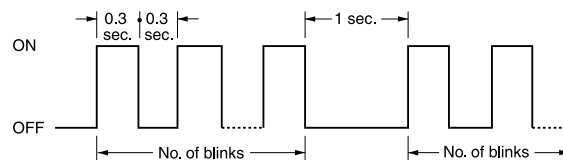

Wiring



Refer to the applicable regulations for the region where this device is to be used when setting up the device. In addition, make sure that all necessary measures are taken to prevent possible dangerous operating errors resulting from earth faults.

- Make sure that the power supply is off while wiring.
- Verify that the supply voltage variation is within the rating.
- If power is supplied from a commercial switching regulator, ensure that the frame ground (F.G.) terminal of the power supply is connected to an actual ground.
- In case noise generating equipment (switching regulator, inverter motor, etc.) is used in the vicinity of this sensor, connect the frame ground (F.G.) terminal of the equipment to an actual ground.
- Do not run the wires together with high-voltage lines or power lines or put them in the same raceway. This can cause malfunction due to induction.

Others

- Do not use during the initial transient time (2 sec.) after the power supply is switched on.
- Avoid dust, dirt and steam.
- Take care that the sensor does not come in direct contact with water, oil, grease, or organic solvents, such as, thinner, etc.
- Take care that the sensor is not directly exposed to fluorescent light from a rapid-starter lamp or a high frequency lighting device, as it may affect the sensing performance.



- Do not utilize this sensor in 'PSDI Mode', in which the sensor is utilized as an activator for machinery.
- To use this product in the U.S.A., refer to OSHA 1910. 212 and OSHA 1910. 217 for installation, and in Europe, refer to EN 999 as well. Observe your national and local requirements before installing this product.
- This sensor is a Type 2 electro-sensitive protective equipment. It is specified that this sensor be utilized only within systems implementing safety categories 2, 1 and B (safety-related categories for control systems), as determined by European Standard EN 954-1. This sensor must never be utilized in any system that requires the usage of category 4 equipment, such as press machines; nor for systems requiring category 3 equipment.

- This catalog is a guide to select a suitable product. Be sure to read the instruction manual attached to the product prior to its use.

- Make sure to carry out the test run before regular operation.
- This safety system is for use only on machinery in which the dangerous parts can be stopped immediately, either by an emergency stop unit or by disconnecting the power supply. Do not use this system with machinery which cannot be stopped at any point in its operation cycle.

PRECAUTIONS FOR PROPER USE

Sensing area



- Make sure to install this product such that any part of the human body that passes through the sensing area is detected before it reaches dangerous machine parts. If the human body is not detected, there is a danger of serious injury or death.
- Do not use any reflective type or retroreflective type arrangement.

Correct mounting method

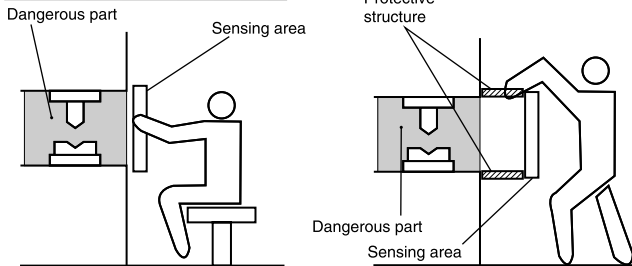

Wrong mounting method

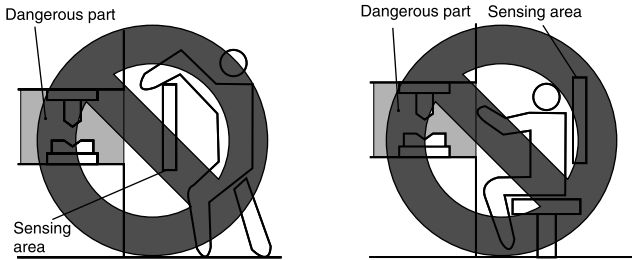

Safety distance



- Calculate the safety distance correctly, and always maintain a distance which is equal to or greater than the safety distance, between the sensing area of this sensor and the dangerous parts of the machinery. If the safety distance is miscalculated or if sufficient distance is not maintained, there is a danger of serious injury or death.
- Before designing the system, refer to the relevant standards of the region where this device is to be used and then install this device.

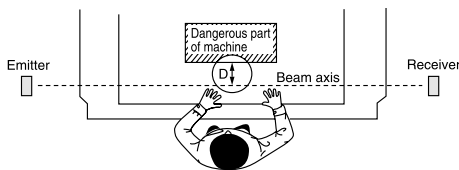

- Safety distance is calculated based on the following equation when a person moves perpendicular (normal intrusion) to the sensing area of the sensor. (Please check the latest standards for the equation.)

For use in Europe (as per EN 999)

- Equation ① $D = K \times T + C$
D: Safety distance (mm)
 Minimum required distance between the surface of the sensing area and dangerous part of machine.
K: Intrusion speed of operator's body or objects (mm/sec.)
 Normally, taken as **SF2-AH□(-PN)(-H)** 2,000 (mm/sec.), **SF2-AA□(-PN)(-H)** 1,600 (mm/sec.) for calculation.
T: Response time of total equipment (sec.)
 $T = T_m + T_{SF2}$
T_m: Maximum halt time of device (sec.)
T_{SF2}: Response time of the **SF2-A** series 0.015 (sec.)
C: Additional distance calculated from the size of the minimum sensing object of the sensor (mm)
 Note that the value of C is not less than or equal to 0.
 $C = 8 \times (d - 14)$
d: Minimum sensing object diameter
SF2-AH□(-PN)(-H) 30 (mm) 1.181 (in)
For SF2-AA□(-PN)(-H), C = 850 (mm) 33.465 (in) (constant)

For use in U.S.A. (as per ANSI B11.19)

- Equation ② $D = K \times (T_s + T_c + T_{SF2} + T_{bm}) + D_{pf}$
D: Safety distance (mm)
 Minimum required distance between the surface of the sensing area and dangerous part of machine.
K: Intrusion speed {Recommended value in OSHA is 63 (inch/sec.) [$\approx 1,600$ (mm/sec.)]}
 ANSI B11.19 does not define the intrusion speed (K). When determining K, consider possible factors including physical ability of operators.
T_s: Halt time calculated from the operation time of the control element (air valve, etc.) (sec.)
T_c: Maximum response time of the control circuit required for the brake to function. (sec.)
T_{SF2}: Response time of the **SF2-A** series 0.015 (sec.)
T_{bm}: Additional halt time tolerance for the brake monitor (sec.)
 $T_{bm} = T_a - (T_s + T_c)$
T_a: Setting time of brake monitor (sec.)
 When the machine is not equipped with a break monitor, it is recommended that 20 % or more of (T_s + T_c) is taken as additional halting time.
D_{pf}: Additional distance calculated from the size of the minimum sensing object of the sensor (mm)
SF2-AH□(-PN)(-H) D_{pf} = 78.2 mm 3.079 in,
SF2-AA□(-PN)(-H) D_{pf} = 146.2 mm 5.756 in
 $D_{pf} = 3.4 \times (d - 0.276)$ (inch)
 $D_{pf} = 3.4 \times (d - 7)$ (mm)
d: Minimum sensing object diameter 1.2 (inch) ≈ 30 (mm)
SF2-AH□(-PN)(-H)
 Minimum sensing object diameter 2.0 (inch) ≈ 50 (mm)
SF2-AA□(-PN)(-H)
 Note that the value of D_{pf} is not less than or equal to 0.

Influence of reflective surface



- Install the sensor by considering the effect of nearby reflective surfaces and taking suitable countermeasures. Failure to do so may cause the sensor not to detect, resulting in serious injury or death.

- Keep the minimum distance given below, between the sensor and a reflective surface.

Side view

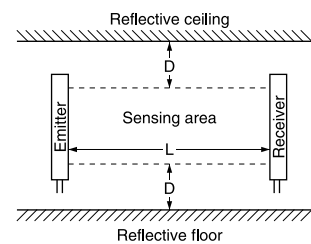

Top view

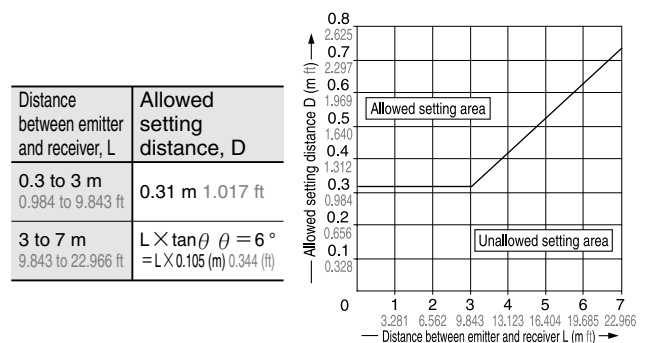
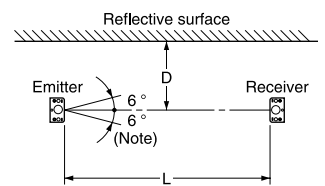

Note: The effective aperture angle for this sensor is $\pm 5^\circ$ (with $L > 3$ m 9.843 ft) as required by IEC 61496-2 / UL 61496-2. However, install this sensor away from the reflective surfaces, assuming an effective aperture angle of $\pm 6^\circ$ to provide for misalignment, etc., during installation.

SF2-A

PRECAUTIONS FOR PROPER USE

Mounting

- The minimum bending radius of the cable is R30 mm R1.181 in. Mount the sensor considering the cable bending radius.

Mounting of sensor mounting bracket (MS-SF2N-1/3/5)

- Choose the sensor mounting bracket based on the mounting direction (side or rear), and temporarily tighten the brackets with two M3 (length 5 mm 0.197 in) hexagon-socket-head bolts for adjusting the mounting angle. After the beam-axis alignment, tighten then bolts completely. When mounting the sensor, the tightening torque should be 0.6 N·m or less.

<Back mounting>

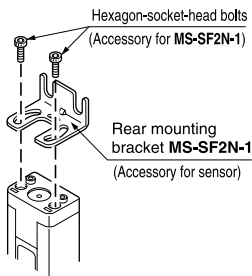

<Side mounting>

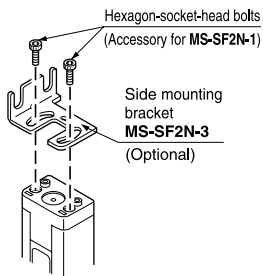

<Center sensor mounting bracket>

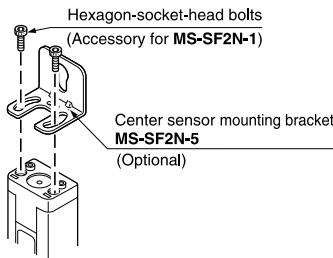

Note: Multiple beam channel sensors requiring the intermediate supporting bracket (20 mm 0.787 in beam pitch type: 36 beam channels or more, 40 mm 1.575 in beam pitch type: 18 beam channels or more) cannot be mounted on an aluminum frame with the center sensor mounting bracket (MS-SF2N-5).

Mounting of intermediate supporting bracket (MS-SF2N-2/4, MS-SF4A-H2/H4)

- Place the retaining plate on the U-shaped rear / side supporting bracket and temporarily tighten them with an M3 (length 10 mm 0.394 in) pan head screw.
- Temporarily tighten the L-shaped intermediate supporting bracket to the U-shaped rear / side supporting bracket with an M4 (length 10 mm 0.394 in) hexagon-socket-head bolt.

<Back mounting>

MS-SF2N-2 / MS-SF4A-H2
(U-shaped rear supporting bracket, retaining plate)

<Side mounting>

MS-SF2N-4 / MS-SF4A-H4
(U-shaped side supporting bracket, retaining plate)

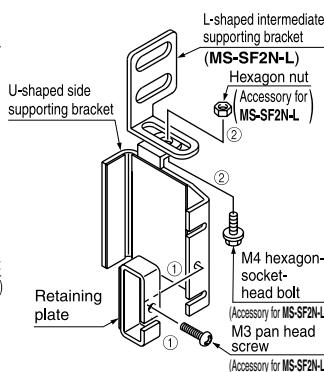
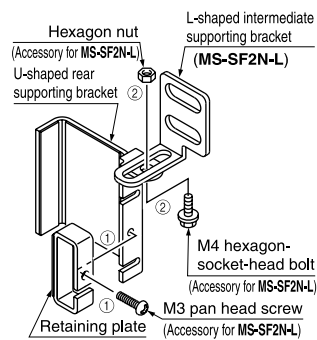

Note: The above figures are only applicable to the MS-SF2N-2/4. The MS-SF4A-H2/H4 have different shapes.

- Clamp the sensor main body with the U-shaped rear / side supporting bracket and completely tighten the M3 pan head screw that secures the retaining plate. (Tightening torque: 0.4 N·m or less) After the beam-axis alignment, ensure that the M4 hexagon-socket-head bolt, which was used to temporarily attach the L-shaped intermediate supporting bracket to the U-shaped rear / side supporting bracket, is now fully tightened. (Tightening torque: 1.8 N·m or less)

<Back mounting>

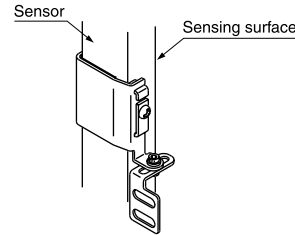

<Side mounting>

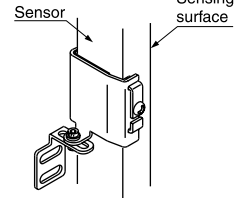

Note: The above figures show how to mount the emitter onto the intermediate supporting brackets. Note that the top and bottom orientation will be reversed when mounting the receiver to the supporting brackets.

Test input (self-diagnosis function) / Emission halt function

! In order to maintain safety, carry out the self-diagnosis at least once a day.

- If the test input wire is made open for 45 ms or more, or connected to $V_s - 1.5\text{ V}$ to V_s (PNP output type: 0 to +1.5 V) detailed diagnosis, in addition to the internal self-diagnosis being done during normal operation, is carried out. In case no abnormality is discovered during self-diagnosis, and if the test input is continued to be kept open after that, emission halt state is achieved. In case an abnormality is discovered during self-diagnosis, the device is put in the lockout state at that instant, and the control output (OSSD) and alarm outputs are fixed at the OFF state.
- Emission halt state is achieved when no abnormality is detected during self-diagnosis and the test input is continued to be kept open after that. During emission halt, control output (OSSD) and alarm output switch to the OFF state. By using this function, malfunction due to extraneous noise, or abnormality in control output (OSSD) and alarm output, can be determined even from the equipment side.

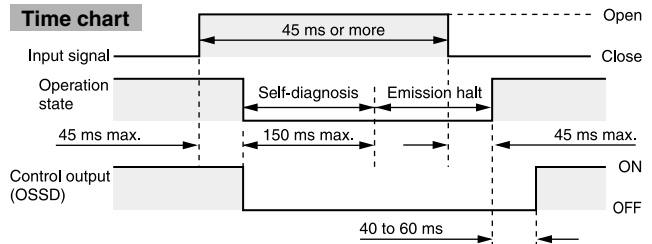

Alarm output

! Be sure to use the alarm output.

- Since the occurrence of a fault, such as that due to an external short-circuit, cannot be conveyed to the equipment side by control output (OSSD), the alarm output generates a warning signal. Design a system such that the equipment can be stopped when either control output (OSSD) or alarm output is output.

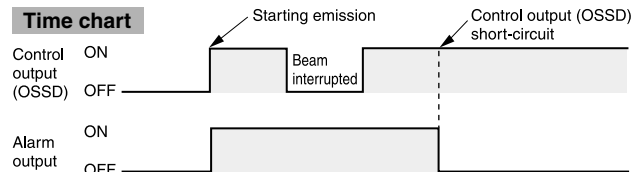

DIMENSIONS (Unit: mm in)

SF2-AH□(-PN)
SF2-AA□(-PN) Sensor

Assembly dimensions

Mounting drawing for the sensor on which the sensor mounting brackets and the intermediate supporting brackets are mounted.

<Back mounting>

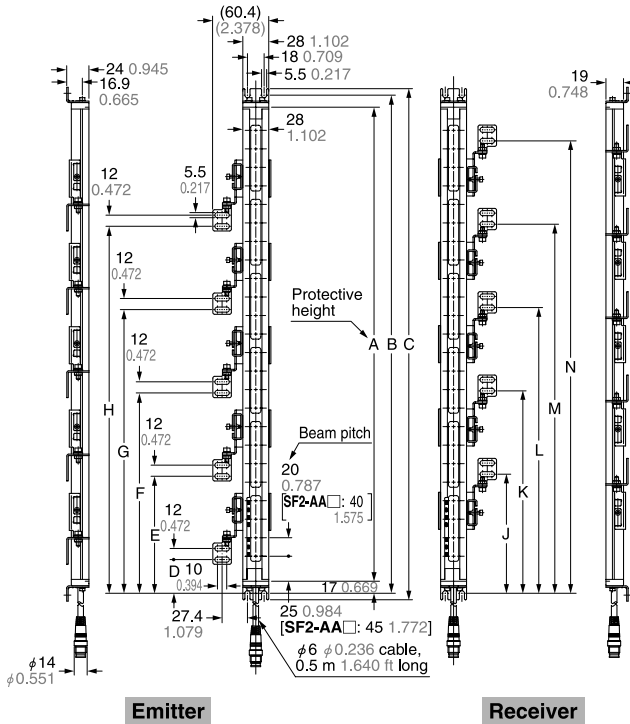

<Side mounting>

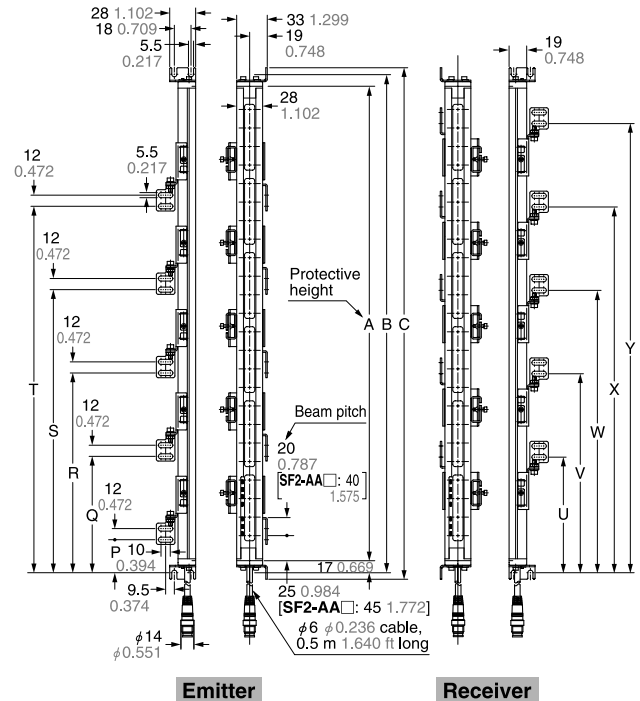

Model No.	A	B	C	D	E	F	G	H	J	K	L	M	N
SF2-AH8(-PN) SF2-AA4(-PN)	190 7.480	222 8.740	232 9.134	-	-	-	-	-	-	-	-	-	-
SF2-AH12(-PN) SF2-AA6(-PN)	270 10.630	302 11.890	312 12.283	-	-	-	-	-	-	-	-	-	-
SF2-AH16(-PN) SF2-AA8(-PN)	350 13.780	382 15.039	392 15.433	-	-	-	-	-	-	-	-	-	-
SF2-AH20(-PN) SF2-AA10(-PN)	430 16.929	462 18.169	472 18.563	-	-	-	-	-	-	-	-	-	-
SF2-AH24(-PN) SF2-AA12(-PN)	510 20.079	542 21.339	552 21.372	-	-	-	-	-	-	-	-	-	-
SF2-AH28(-PN) SF2-AA14(-PN)	590 23.228	622 24.488	632 24.882	-	-	-	-	-	-	-	-	-	-
SF2-AH32(-PN) SF2-AA16(-PN)	670 26.378	702 27.638	712 28.031	-	-	-	-	-	-	-	-	-	-
SF2-AH36(-PN) SF2-AA18(-PN)	750 29.528	782 30.787	792 31.181	-	-	-	-	-	433 17.047	-	-	-	-
SF2-AH40(-PN) SF2-AA20(-PN)	830 32.677	862 33.937	872 34.331	377 14.842	-	-	-	-	473 18.622	-	-	-	-
SF2-AH48(-PN) SF2-AA24(-PN)	990 38.976	1,022 40.236	1,032 40.630	377 14.842	537 21.142	-	-	-	473 18.622	633 24.921	-	-	-
SF2-AH56(-PN) SF2-AA28(-PN)	1,150 45.276	1,182 46.535	1,192 46.929	377 14.842	537 21.142	697 27.441	-	-	473 18.622	633 24.921	793 31.220	-	-
SF2-AH64(-PN) SF2-AA32(-PN)	1,310 51.575	1,342 52.835	1,352 53.228	457 17.992	617 24.291	777 30.590	-	-	553 21.772	713 28.071	873 34.370	-	-
SF2-AH72(-PN) SF2-AA36(-PN)	1,470 57.874	1,502 59.134	1,512 59.527	537 21.142	697 27.441	857 33.740	-	-	633 24.921	793 31.220	953 37.520	-	-
SF2-AH80(-PN) SF2-AA40(-PN)	1,630 64.173	1,662 65.433	1,672 65.827	537 21.142	697 27.441	857 33.740	1,017 40.039	-	633 24.921	793 31.220	953 37.520	1,113 43.819	-
SF2-AH88(-PN) SF2-AA44(-PN)	1,790 70.472	1,822 71.732	1,832 72.126	537 21.142	697 27.441	857 33.740	1,017 40.039	1,177 46.338	633 24.921	793 31.220	953 37.520	1,113 43.819	1,273 50.118
SF2-AH96(-PN) SF2-AA48(-PN)	1,950 76.772	1,982 78.031	1,992 78.425	617 24.291	777 30.590	937 36.890	1,097 43.189	1,257 49.488	713 28.071	873 34.370	1,033 40.669	1,193 46.968	1,353 53.268

Model No.	A	B	C	P	Q	R	S	T	U	V	W	X	Y
SF2-AH8(-PN) SF2-AA4(-PN)	190 7.480	222 8.740	232 9.134	-	-	-	-	-	-	-	-	-	-
SF2-AH12(-PN) SF2-AA6(-PN)	270 10.630	302 11.890	312 12.283	-	-	-	-	-	-	-	-	-	-
SF2-AH16(-PN) SF2-AA8(-PN)	350 13.780	382 15.039	392 15.433	-	-	-	-	-	-	-	-	-	-
SF2-AH20(-PN) SF2-AA10(-PN)	430 16.929	462 18.169	472 18.563	-	-	-	-	-	-	-	-	-	-
SF2-AH24(-PN) SF2-AA12(-PN)	510 20.079	542 21.339	552 21.372	-	-	-	-	-	-	-	-	-	-
SF2-AH28(-PN) SF2-AA14(-PN)	590 23.228	622 24.488	632 24.882	-	-	-	-	-	-	-	-	-	-
SF2-AH32(-PN) SF2-AA16(-PN)	670 26.378	702 27.638	712 28.031	-	-	-	-	-	-	-	-	-	-
SF2-AH36(-PN) SF2-AA18(-PN)	750 29.528	782 30.787	792 31.181	340 13.386	-	-	-	-	430 16.929	-	-	-	-
SF2-AH40(-PN) SF2-AA20(-PN)	830 32.677	862 33.937	872 34.331	380 14.961	-	-	-	-	470 18.504	-	-	-	-
SF2-AH48(-PN) SF2-AA24(-PN)	990 38.976	1,022 40.236	1,032 40.630	380 14.961	540 21.260	-	-	-	470 18.504	630 24.803	-	-	-
SF2-AH56(-PN) SF2-AA28(-PN)	1,150 45.276	1,182 46.535	1,192 46.929	380 14.961	540 21.260	700 27.559	-	-	470 18.504	630 24.803	790 31.102	-	-
SF2-AH64(-PN) SF2-AA32(-PN)	1,310 51.575	1,342 52.835	1,352 53.228	460 18.110	620 24.409	780 30.709	-	-	550 21.654	710 27.953	870 34.252	-	-
SF2-AH72(-PN) SF2-AA36(-PN)	1,470 57.874	1,502 59.134	1,512 59.527	540 21.260	700 27.559	860 33.858	-	-	630 24.803	790 31.102	950 37.402	-	-
SF2-AH80(-PN) SF2-AA40(-PN)	1,630 64.173	1,662 65.433	1,672 65.827	540 21.260	700 27.559	860 33.858	1,020 40.157	-	630 24.803	790 31.102	950 37.402	1,110 43.701	-
SF2-AH88(-PN) SF2-AA44(-PN)	1,790 70.472	1,822 71.732	1,832 72.126	540 21.260	700 27.559	860 33.858	1,020 40.157	1,180 46.457	630 24.803	790 31.102	950 37.402	1,110 43.701	1,270 50.000
SF2-AH96(-PN) SF2-AA48(-PN)	1,950 76.772	1,982 78.031	1,992 78.425	620 24.409	780 30.709	940 37.008	1,100 43.307	1,260 49.606	710 27.953	870 34.252	1,030 40.551	1,190 46.850	1,350 53.150

SF2-A

DIMENSIONS (Unit: mm in)

SF2-AH□(-PN)-H
SF2-AA□(-PN)-H Sensor

Assembly dimensions

Mounting drawing for the sensor on which the sensor mounting brackets and the intermediate supporting brackets are mounted.

<Back mounting>

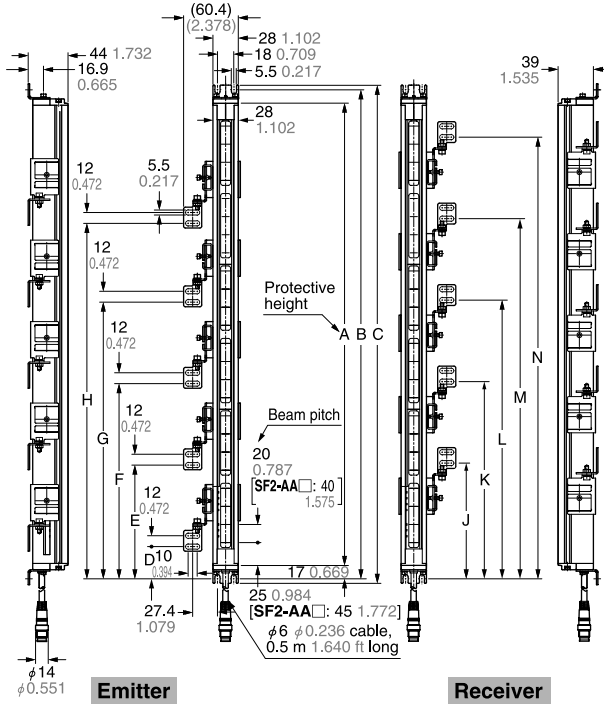

<Side mounting>

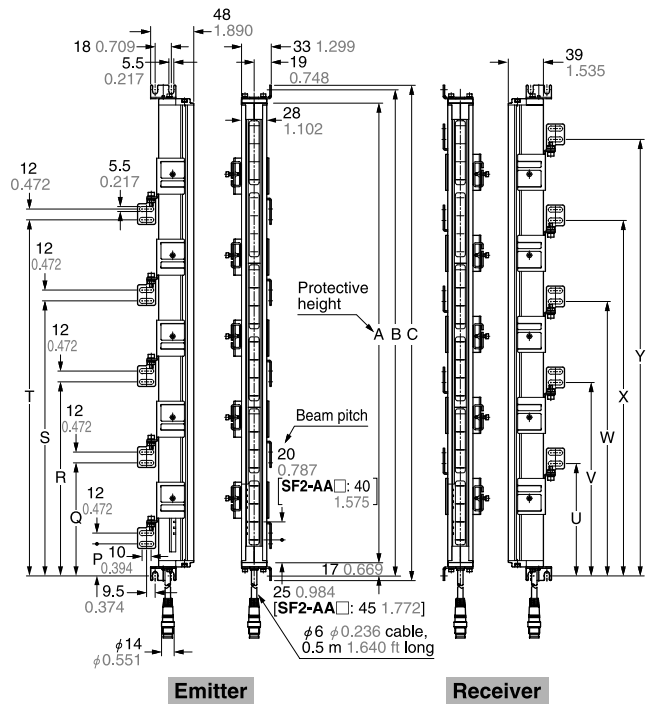

Model No.	A	B	C	D	E	F	G	H	J	K	L	M	N
SF2-AH8(-PN)-H	190	222	232	-	-	-	-	-	-	-	-	-	-
SF2-AA4(-PN)-H	7.480	8.740	9.134	-	-	-	-	-	-	-	-	-	-
SF2-AH12(-PN)-H	270	302	312	-	-	-	-	-	-	-	-	-	-
SF2-AA6(-PN)-H	10.630	11.890	12.283	-	-	-	-	-	-	-	-	-	-
SF2-AH16(-PN)-H	350	382	392	-	-	-	-	-	-	-	-	-	-
SF2-AA8(-PN)-H	13.780	15.039	15.433	-	-	-	-	-	-	-	-	-	-
SF2-AH20(-PN)-H	430	462	472	-	-	-	-	-	-	-	-	-	-
SF2-AA10(-PN)-H	16.929	18.189	18.583	-	-	-	-	-	-	-	-	-	-
SF2-AH24(-PN)-H	510	542	552	-	-	-	-	-	-	-	-	-	-
SF2-AA12(-PN)-H	20.079	21.339	21.372	-	-	-	-	-	-	-	-	-	-
SF2-AH28(-PN)-H	590	622	632	-	-	-	-	-	-	-	-	-	-
SF2-AA14(-PN)-H	23.228	24.488	24.682	-	-	-	-	-	-	-	-	-	-
SF2-AH32(-PN)-H	670	702	712	-	-	-	-	-	-	-	-	-	-
SF2-AA16(-PN)-H	26.378	27.638	28.031	-	-	-	-	-	-	-	-	-	-
SF2-AH36(-PN)-H	750	782	792	337	-	-	-	-	433	-	-	-	-
SF2-AA18(-PN)-H	29.528	30.787	31.181	13.268	-	-	-	-	17.047	-	-	-	-
SF2-AH40(-PN)-H	830	862	872	377	-	-	-	-	473	-	-	-	-
SF2-AA20(-PN)-H	32.677	33.937	34.331	14.842	-	-	-	-	18.622	-	-	-	-
SF2-AH48(-PN)-H	990	1,022	1,032	377	537	-	-	-	473	633	-	-	-
SF2-AA24(-PN)-H	38.976	40.236	40.630	14.842	21.142	-	-	-	18.622	24.921	-	-	-
SF2-AH56(-PN)-H	1,150	1,182	1,192	377	537	697	-	-	473	633	793	-	-
SF2-AA28(-PN)-H	45.276	46.535	46.929	14.842	21.142	27.441	-	-	18.622	24.921	31.220	-	-
SF2-AH64(-PN)-H	1,310	1,342	1,352	457	617	777	-	-	553	713	873	-	-
SF2-AA32(-PN)-H	51.575	52.835	53.228	17.992	24.291	30.590	-	-	21.772	26.071	34.370	-	-
SF2-AH72(-PN)-H	1,470	1,502	1,512	537	697	857	-	-	633	793	953	-	-
SF2-AA36(-PN)-H	57.874	59.134	59.527	21.142	27.441	33.740	-	-	24.921	31.220	37.520	-	-
SF2-AH80(-PN)-H	1,630	1,662	1,672	537	697	857	1,017	-	633	793	953	1,113	-
SF2-AA40(-PN)-H	64.173	65.433	65.827	21.142	27.441	33.740	40.039	-	24.921	31.220	37.520	43.819	-
SF2-AH88(-PN)-H	1,790	1,822	1,832	537	697	857	1,017	1,177	633	793	953	1,113	1,273
SF2-AA44(-PN)-H	70.472	71.732	72.126	21.142	27.441	33.740	40.039	46.338	24.921	31.220	37.520	43.819	50.118
SF2-AH96(-PN)-H	1,950	1,982	1,992	617	777	937	1,097	1,257	713	873	1,033	1,193	1,353
SF2-AA48(-PN)-H	76.772	78.031	78.425	24.291	30.590	36.890	43.189	49.488	28.071	34.370	40.669	46.968	53.268

Model No.	A	B	C	P	Q	R	S	T	U	V	W	X	Y
SF2-AH8(-PN)-H	190	222	232	-	-	-	-	-	-	-	-	-	-
SF2-AA4(-PN)-H	7.480	8.740	9.134	-	-	-	-	-	-	-	-	-	-
SF2-AH12(-PN)-H	270	302	312	-	-	-	-	-	-	-	-	-	-
SF2-AA6(-PN)-H	10.630	11.890	12.283	-	-	-	-	-	-	-	-	-	-
SF2-AH16(-PN)-H	350	382	392	-	-	-	-	-	-	-	-	-	-
SF2-AA8(-PN)-H	13.780	15.039	15.433	-	-	-	-	-	-	-	-	-	-
SF2-AH20(-PN)-H	430	462	472	-	-	-	-	-	-	-	-	-	-
SF2-AA10(-PN)-H	16.929	18.189	18.583	-	-	-	-	-	-	-	-	-	-
SF2-AH24(-PN)-H	510	542	552	-	-	-	-	-	-	-	-	-	-
SF2-AA12(-PN)-H	20.079	21.339	21.372	-	-	-	-	-	-	-	-	-	-
SF2-AH28(-PN)-H	590	622	632	-	-	-	-	-	-	-	-	-	-
SF2-AA14(-PN)-H	23.228	24.488	24.682	-	-	-	-	-	-	-	-	-	-
SF2-AH32(-PN)-H	670	702	712	-	-	-	-	-	-	-	-	-	-
SF2-AA16(-PN)-H	26.378	27.638	28.031	-	-	-	-	-	-	-	-	-	-
SF2-AH36(-PN)-H	750	782	792	340	-	-	-	-	430	-	-	-	-
SF2-AA18(-PN)-H	29.528	30.787	31.181	13.386	-	-	-	-	16.929	-	-	-	-
SF2-AH40(-PN)-H	830	862	872	380	-	-	-	-	470	-	-	-	-
SF2-AA20(-PN)-H	32.677	33.937	34.331	14.961	-	-	-	-	18.504	-	-	-	-
SF2-AH48(-PN)-H	990	1,022	1,032	380	540	-	-	-	470	630	-	-	-
SF2-AA24(-PN)-H	38.976	40.236	40.630	14.961	21.260	-	-	-	18.504	24.803	-	-	-
SF2-AH56(-PN)-H	1,150	1,182	1,192	380	540	700	-	-	470	630	790	-	-
SF2-AA28(-PN)-H	45.276	46.535	46.929	14.961	21.260	27.559	-	-	18.504	24.803	31.102	-	-
SF2-AH64(-PN)-H	1,310	1,342	1,352	460	620	780	-	-	550	710	870	-	-
SF2-AA32(-PN)-H	51.575	52.835	53.228	18.110	24.409	30.709	-	-	21.654	27.953	34.252	-	-
SF2-AH72(-PN)-H	1,470	1,502	1,512	540	700	860	-	-	630	790	950	-	-
SF2-AA36(-PN)-H	57.874	59.134	59.527	21.260	27.559	33.858	-	-	31.102	37.402	43.701	-	-
SF2-AH80(-PN)-H	1,630	1,662	1,672	540	700	860	1,020	-	630	790	950	1,110	-
SF2-AA40(-PN)-H	64.173	65.433	65.827	21.260	27.559	33.858	40.157	-	24.803	31.102	37.402	43.701	-
SF2-AH88(-PN)-H	1,790	1,822	1,832	540	700	860	1,020	1,180	630	790	950	1,110	1,270
SF2-AA44(-PN)-H	70.472	71.732	72.126	21.260	27.559	33.858	40.157	46.457	24.803	31.102	37.402	43.701	50.000
SF2-AH96(-PN)-H	1,950	1,982	1,992	620	780	940	1,100	1,260	710	870	1,030	1,190	1,350
SF2-AA48(-PN)-H	76.772	78.031	78.425	24.409	30.709	37.008	43.307	49.606	27.953	34.252	40.551	46.850	53.150

DIMENSIONS (Unit: mm in)

MS-SF2N-1 Rear mounting bracket (Accessory for sensor)

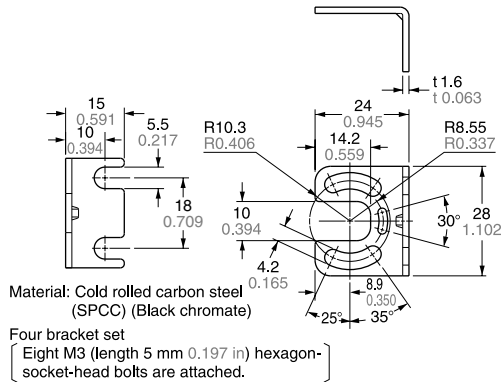

SF-IND-2 Large display unit for light curtain (Optional)

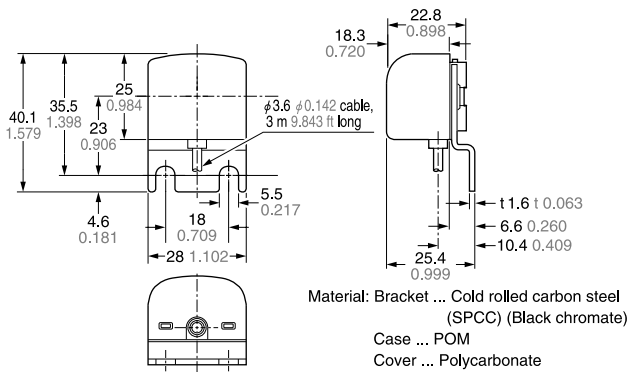

MS-SF4A-H2 U-shaped rear mounting intermediate supporting bracket for SF2-AH□/AA□(-PN)-H [Accessory for SF2-AH□(-PN)-H having 36 beam channels or more and SF2-AA□(-PN)-H having 18 beam channels or more.]

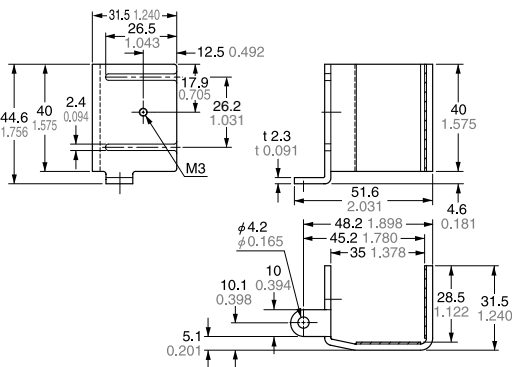

Retaining plate

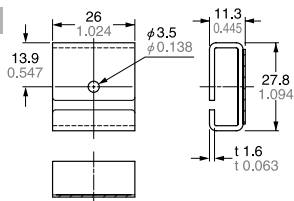

Material: Cold rolled carbon steel (SPCC)(Black chromate)
Set of 2 pcs. each of U-shaped rear supporting bracket and retaining plate (Note)
Note: **MS-SF4A-H2** (U-shaped rear mounting intermediate supporting bracket) is attached with the following sensors. The number of attached U-shaped rear mounting intermediate supporting brackets is different depending on the sensor as follows.
SF2-AH36(-PN)-H, SF2-AH40(-PN)-H, SF2-AA18(-PN)-H, SF2-AA20(-PN)-H: 1 set
SF2-AH48(-PN)-H, SF2-AA24(-PN)-H: 2 sets
SF2-AH56(-PN)-H, SF2-AH64(-PN)-H, SF2-AH72(-PN)-H, SF2-AA28(-PN)-H, SF2-AA32(-PN)-H, SF2-AA36(-PN)-H: 3 sets
SF2-AH80(-PN)-H, SF2-AA40(-PN)-H: 4 sets
SF2-AH88(-PN)-H, SF2-AH96(-PN)-H, SF2-AA44(-PN)-H, SF2-AA48(-PN)-H: 5 sets

MS-SF2N-2 U-shaped rear mounting intermediate supporting bracket for SF2-AH□/AA□(-PN) [Accessory for SF2-AH□(-PN) having 36 beam channels or more and SF2-AA□(-PN) having 18 beam channels or more.]

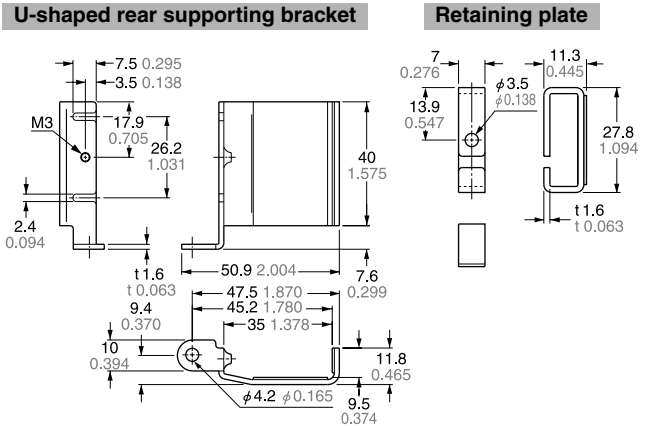

Material: Cold rolled carbon steel (SPCC)(Black chromate)
Set of 2 pcs. each of U-shaped rear supporting bracket and retaining plate (Note)
Note: **MS-SF2N-2** (U-shaped rear mounting intermediate supporting bracket) is attached with the following sensors. The number of attached U-shaped rear mounting intermediate supporting brackets is different depending on the sensor as follows.
SF2-AH36(-PN), SF2-AH40(-PN), SF2-AA18(-PN), SF2-AA20(-PN): 1 set
SF2-AH48(-PN), SF2-AA24(-PN): 2 sets
SF2-AH56(-PN), SF2-AH64(-PN), SF2-AH72(-PN), SF2-AA28(-PN), SF2-AA32(-PN), SF2-AA36(-PN): 3 sets
SF2-AH80(-PN), SF2-AA40(-PN): 4 sets
SF2-AH88(-PN), SF2-AH96(-PN), SF2-AA44(-PN), SF2-AA48(-PN): 5 sets

MS-SF2N-L L-shaped intermediate supporting bracket [Accessory for SF2-AH□(-PN)-H having 36 beam channels or more and SF2-AA□(-PN)-H having 18 beam channels or more.]

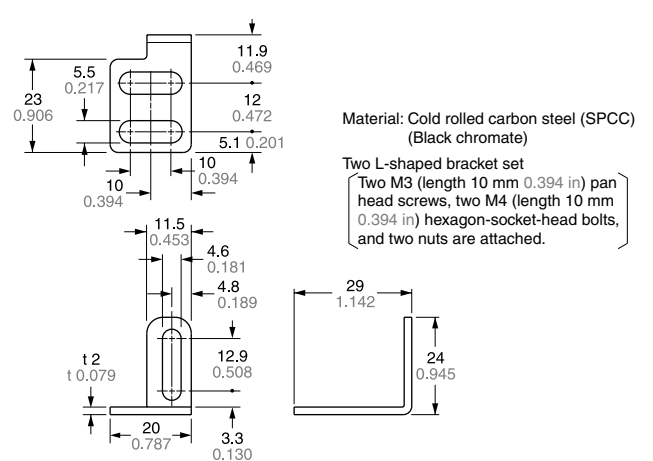

Note: **MS-SF2N-L** (L-shaped intermediate supporting bracket) is attached with the following sensors. The number of attached L-shaped intermediate supporting brackets is different depending on the sensor as follows.
SF2-AH36(-PN)-H, SF2-AH40(-PN)-H, SF2-AA18(-PN)-H, SF2-AA20(-PN)-H: 1 set
SF2-AH48(-PN)-H, SF2-AA24(-PN)-H: 2 sets
SF2-AH56(-PN)-H, SF2-AH64(-PN)-H, SF2-AH72(-PN)-H, SF2-AA28(-PN)-H, SF2-AA32(-PN)-H, SF2-AA36(-PN)-H: 3 sets
SF2-AH80(-PN)-H, SF2-AA40(-PN)-H: 4 sets
SF2-AH88(-PN)-H, SF2-AH96(-PN)-H, SF2-AA44(-PN)-H, SF2-AA48(-PN)-H: 5 sets

SF2-A

DIMENSIONS (Unit: mm in)

MS-SF2N-5 Center sensor mounting bracket (Optional)

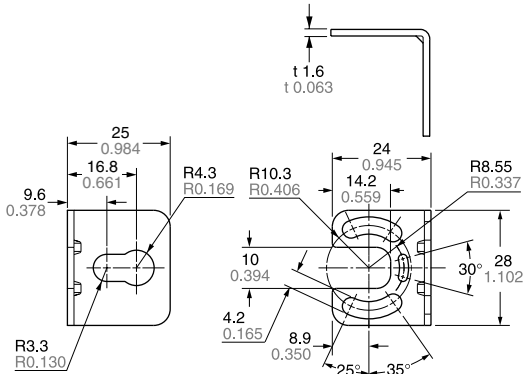

Material: Cold rolled carbon steel (SPCC) (Black chromate)
Four bracket set

MS-SF2N-3 Side mounting bracket (Optional)

Right side-mounting of sensors

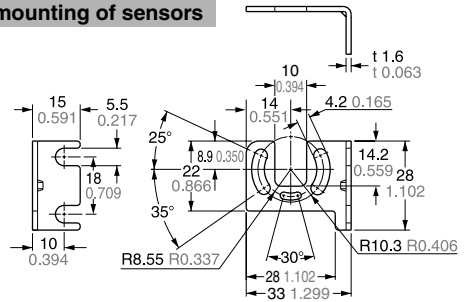

Left side-mounting of sensors

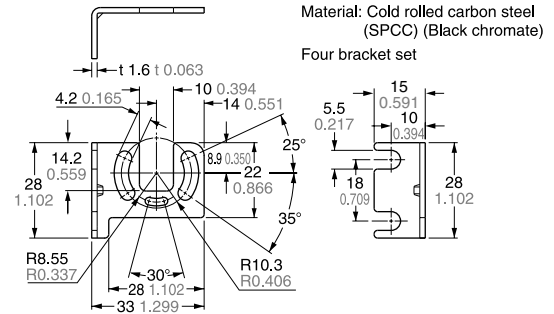

Material: Cold rolled carbon steel (SPCC) (Black chromate)
Four bracket set

MS-SF2N-4 U-shaped side mounting intermediate supporting bracket for SF2-AH□/AA□(-PN) (Optional)

U-shaped side supporting bracket

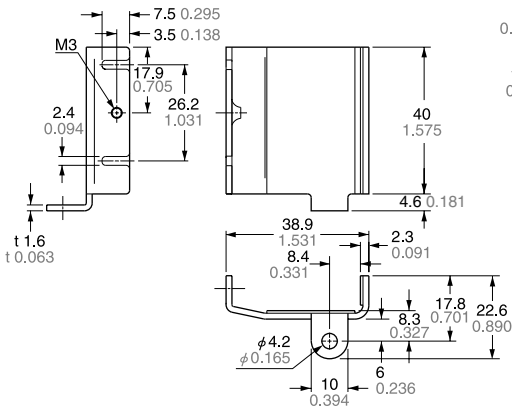

Retaining plate

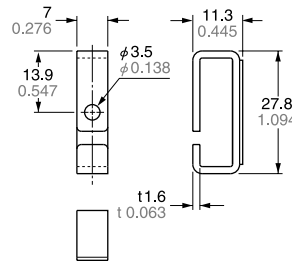

Material: Cold rolled carbon steel (SPCC)(Black chromate)

Set of 2 pcs. each of U-shaped side supporting bracket and retaining plate (Note)

Note: MS-SF2N-4 (U-shaped side mounting intermediate supporting bracket) is attached with the following sensors. The number of attached U-shaped side mounting intermediate supporting bracket is different depending on the sensor as follows.

- SF2-AH36(-PN), SF2-AH40(-PN), SF2-AA18(-PN), SF2-AA20(-PN): 1 set
- SF2-AH48(-PN), SF2-AA24(-PN): 2 sets
- SF2-AH56(-PN), SF2-AH64(-PN), SF2-AH72(-PN), SF2-AA28(-PN), SF2-AA32(-PN), SF2-AA36(-PN): 3 sets
- SF2-AH80(-PN), SF2-AA40(-PN): 4 sets
- SF2-AH88(-PN), SF2-AH96(-PN), SF2-AA44(-PN), SF2-AA48(-PN): 5 sets

MS-SF4A-H4 U-shaped side mounting intermediate supporting bracket for SF2-AH□/AA□(-PN)-H (Optional)

U-shaped side supporting bracket

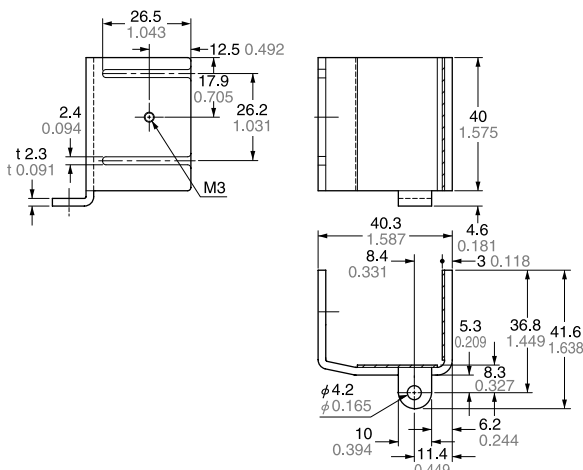

Retaining plate

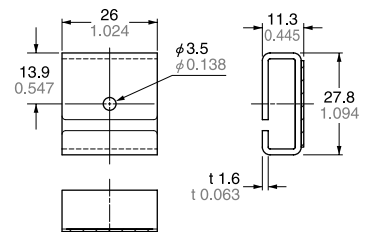

Material: Cold rolled carbon steel (SPCC)(Black chromate)

Set of 2 pcs. each of U-shaped side supporting bracket and retaining plate (Note)

Note: MS-SF4A-H4 (U-shaped side mounting intermediate supporting bracket) is attached with the following sensors. The number of attached U-shaped side mounting intermediate supporting bracket is different depending on the sensor as follows.

- SF2-AH36(-PN)-H, SF2-AH40(-PN)-H, SF2-AA18(-PN)-H, SF2-AA20(-PN)-H: 1 set
- SF2-AH48(-PN)-H, SF2-AA24(-PN)-H: 2 sets
- SF2-AH56(-PN)-H, SF2-AH64(-PN)-H, SF2-AH72(-PN)-H, SF2-AA28(-PN)-H, SF2-AA32(-PN)-H, SF2-AA36(-PN)-H: 3 sets
- SF2-AH80(-PN)-H, SF2-AA40(-PN)-H: 4 sets
- SF2-AH88(-PN)-H, SF2-AH96(-PN)-H, SF2-AA44(-PN)-H, SF2-AA48(-PN)-H: 5 sets