

**Actuator and Sensor Cable, PVC
Connection Cable
RKC8T-2/TEL**

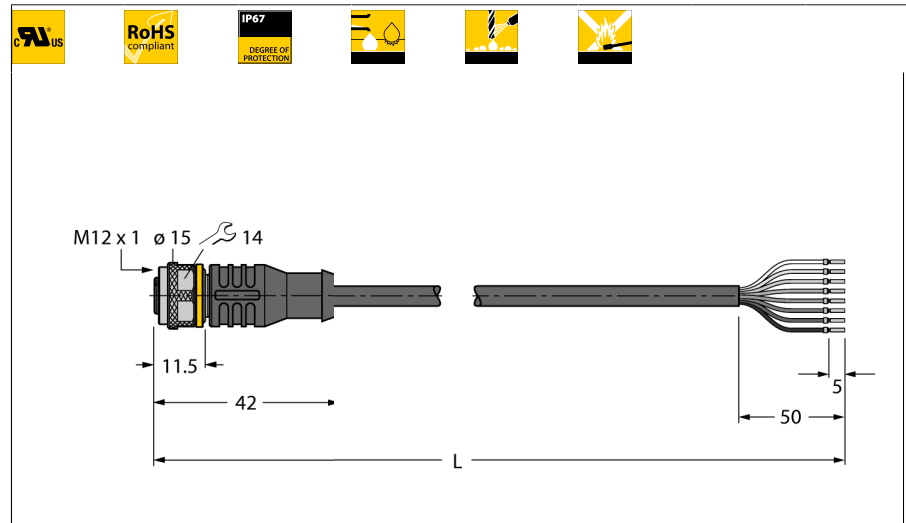

- Female M12, straight, 8-pin
- Sheath material: PVC
- Sheath color: black
- Resistant to chemicals and oils
- Flame retardant
- Resistant to acids and alkaline solutions
- Resistant to microbes and hydrolysis
- LABS free
- Approval: cULus
- RoHS conform
- Protection class IP67
- Cable length: 2.0 m

Cable Cross-section

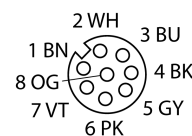
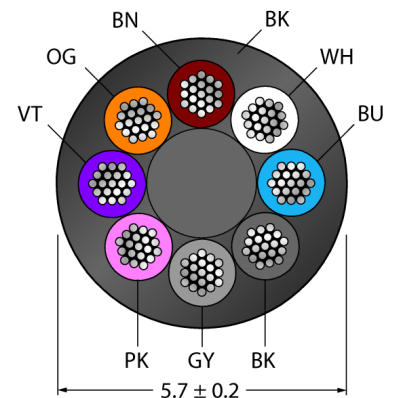

General information

Drawing shows design status including hexagon coupling nut (Production start CW11/2016).
Wiring diagram shows contact assignment acc. to DIN EN 60947-5-2 (Production start CW16/2017).

Circuit Diagram

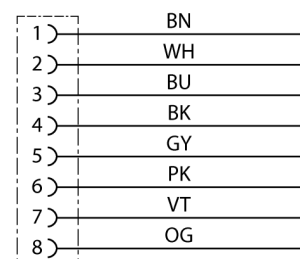

Type designation	RKC8T-2/TEL
Ident no.	6625130
Remark to product	Stranded wire colors and figure may differ.
Connector A	Female, M12x1, Straight
Number of pins	8
Contacts	Brass, CuZn, Gold-plated
Contact carriers	Plastic, TPU, Black
Connector body	Plastic, TPU, Black
Coupling nut/screw	Brass, CuZn, Nickel-plated
Seal	Plastic, FPM/FKM
Protection class	IP67, A + B side screwed together
Mechanical lifespan	> 100 Mating cycles
Pollution degree	3
Tightening torque	0.8 ... 1 Nm (observe max. torque of mating connector!)
General data	
Cable diameter	5.7 ± 0.20mm
Cable length	2 m
Cable quality	PVC
Cable color	Black
Conductor insulation	PVC
Conductor colors	BN, WH, BU, BK, GY, PK, VT, OG
Core cross-section	8x0.25
Arrangement of strands	32x0.1
Electrical properties at +20 °C	
Current	2 A
Rated voltage	30 V
Insulation resistance	> 30.5 MΩ/km
Test voltage	2000 V
Forward resistance	max. 79 Ω/km
Mechanical and chemical properties	
Bending radius (stationary laying)	> 5 x Ø
Bending radius (flexible use)	> 10 x Ø
Ambient temperature	
Stationary	-40...+105°C
In motion	0...+80°C

**Actuator and Sensor Cable, PVC
Connection Cable
RKC8T-2/TEL**

TURCK



Industrial
Automation

Stranded Wire Colors

Pin	DIN 47100 (old)	DIN EN 60947-5-2 (new)
1	WH	BN
2	BN	WH
3	GN	BU
4	YE	BK
5	GY	GY
6	PK	PK
7	BU	VT
8	RD	OG

**Actuator and Sensor Cable, PVC
Connection Cable
RKC8T-2/TEL**

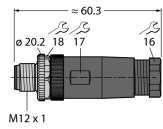
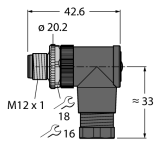
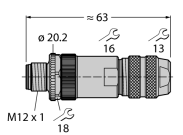
Accessories

Type code	Ident no.	Description	
BS8181-0	6901004	Field-wireable male connector, M12 × 1, straight, 8-pin, screw terminal connection, cable feedthrough 6.0 to 8.0 mm, core cross-section/terminal capacity 0.14 to 0.50 mm ² , plastic housing, metal nut	
BS8281-0	6930862	Field-wireable male connector, M12 × 1, angled, 8-pin, screw terminal connection, cable feedthrough 6.0 to 8.0 mm, core cross-section/terminal capacity 0.14 to 0.50 mm ² , plastic housing, metal nut	
CMBS8181-0	6930792	Field-wireable male connector, M12 × 1, straight, 8-pin, screw terminal connection, cable feedthrough 6.0 to 8.0 mm, core cross-section/terminal capacity 0.14 to 0.50 mm ² , metal housing, metal nut, shieldable, also for Ethernet	
TORQUE-WRENCH-SET-AS	6936170	Torque wrench set; handles with adjustable torque 0.4-1.0 Nm, torque wrench for M8 (SW9), fork wrench for M12 (SW 14)	
BLANK-LABEL-FOR-CORDSETS-TEL-TXL	6936206	Label for TEL and TXL cables, length: 18 mm, height: 4 mm, material: polycarbonate (PC), color: white, halogen-free and flame-retardant	