

Technical Catalogue Relays PNOZ
Version 2016-09

PILZ
THE SPIRIT OF SAFETY

- ▶ Configuration guide
- ▶ Safety relays PNOZ X
- ▶ Safety relays PNOZsigma



Introduction

Relays for functional safety

| | |
|-------------------------|-----|
| Selection guide | 6 |
| Safety relays PNOZ X | 10 |
| Safety relays PNOZsigma | 546 |

Safety relays PNOZ monitor safety functions such as E-STOP, safety gate, light grid, two-hand control and much more.

Safety relays from the product range PNOZ X are proven through their reliability and robustness and have developed a wide application range in the most varied of safety applications. PNOZ is the most widely used safety relay in the world. One PNOZ is used per safety function.

The compact safety relays PNOZsigma combine many years of experience with today's very latest safety technology: with little effort they can achieve maximum safety and cost effectiveness. With particularly narrow housing widths and multifunctionality compressed into each unit, PNOZsigma represents maximum functionality in minimum width. So you can implement safety technology faster, with greater flexibility and therefore more efficiently, while saving space.

This catalogue contains a selection guide as well as a description of the individual products in the product ranges PNOZ X and PNOZsigma. Each unit is described in a detailed data sheet, helping you to select the units and also enabling configuration.

Further information on the products is available in the operating manuals for the respective units. Please read the operating instructions before commissioning.



| Contents | Page |
|-------------------------|-------------|
| Selection guide | 6 |
| Safety relays PNOZ X | 10 |
| Safety relays PNOZsigma | 546 |

Selection guide PNOZ X

| Type | Application | | | | | | Performance Level (PL) - EN ISO 13849-1 | Safety Integrity Level (SIL) CL – Claim limit in accordance with IEC 62061 | Output contacts | | | | Housing width in mm | |
|--------------|-------------------|---|---|--|--|--|---|--|-----------------|---|--------------------|---|---------------------|------|
| | | | | | | | | | Safety-related | | Not safety-related | | | |
| | | | | | | | | | | | | | | |
| PNOZ X1P | ♦ | ♦ | | | | | e | 3 | 3 | - | 1 | - | 22.5 | |
| PNOZ X2P | ♦ | ♦ | | | | | e | 3 | 2 | - | - | - | 22.5 | |
| PNOZ X2.1VP | ♦ | ♦ | | | | | d | 3 | 2 | 2 | - | 1 | 22.5 | |
| PNOZ X2.3P | ♦ | ♦ | | | | | e | 3 | 3 | - | - | - | 22.5 | |
| PNOZ X2.7P | ♦ | ♦ | ♦ | | | | e | 3 | 3 | - | 1 | - | 22.5 | |
| PNOZ X2.8P | ♦ | ♦ | ♦ | | | | e | 3 | 3 | - | 1 | - | 22.5 | |
| PNOZ X2.9P | ♦ | ♦ | ♦ | | | | e | 3 | 3 | - | 1 | - | 22.5 | |
| PNOZ X3P | ♦ | ♦ | ♦ | | | | e | 3 | 3 | - | 1 | 1 | 45.0 | |
| PNOZ X3.10P | ♦ | ♦ | ♦ | | | | e | 3 | 3 | - | 1 | 1 | 45.0 | |
| PNOZ X7P | ♦ | ♦ | | | | | e | 3 | 2 | - | - | - | 22.5 | |
| PNOZ X8P | ♦ | ♦ | ♦ | | | | e | 3 | 3 | - | 2 | 2 | 45.0 | |
| PNOZ X9P | ♦ | ♦ | ♦ | | | | e | 3 | 7 | - | 2 | 2 | 90.0 | |
| PNOZ X10.11P | ♦ | ♦ | ♦ | | | | e | 3 | 6 | - | 4 | - | 90.0 | |
| PNOZ X11P | ♦ | ♦ | | | | | e | 3 | 7 | - | 1 | 2 | 90.0 | |
| PNOZ XV1P | ♦ | ♦ | ♦ | | | | e (d) * | 3 | 2 | 1 | - | - | 22.5 | |
| PNOZ XV2P | ♦ | ♦ | | | | | e (d) * | 3 | 2 | 2 | - | - | 45.0 | |
| PNOZ XV2.1P | ♦ | ♦ | | | | | e (d) * | 3 | 2 | 2 | - | - | 90.0 | |
| PNOZ XV3P | ♦ | ♦ | ♦ | | | | e (d) * | 3 | 3 | 2 | - | - | 45.0 | |
| PNOZ XV3.1P | ♦ | ♦ | ♦ | | | | e (d) * | 3 | 3 | 2 | 1 | - | 90.0 | |
| PZE X4P | Contact expansion | | | | | | | e | 3 | 4 | - | - | - | 22.5 |
| PZE X4.1P | Contact expansion | | | | | | | e | 3 | 4 | - | - | - | 22.5 |
| PZE X4VP | Contact expansion | | | | | | | d | 2 | 4 | - | - | - | 22.5 |
| PZE X4VP4 | Contact expansion | | | | | | | d | 2 | 4 | - | - | - | 45.0 |
| PZE X4VP8 | Contact expansion | | | | | | | d | 2 | 4 | - | - | - | 45.0 |

Selection guide PNOZ X







| Type | Application | | | | | | Performance Level (PL) - EN ISO 13849-1 | Safety Integrity Level (SIL) CL – Claim limit in accordance with IEC 62061 | Output contacts | | | | Housing width in mm |
|----------|-------------------|--|---|---|--|---|---|--|-----------------|---|--------------------|---|---------------------|
| | | | | | | | | | Safety-related | | Not safety-related | | |
| PZE X5P | Contact expansion | | | | | | e | 3 | 5 | - | - | 2 | 45.0 |
| PZE 9P | Contact expansion | | | | | | e | 3 | 8 | - | 1 | - | 90.0 |
| PMUT X1P | ◆ | | ◆ | ◆ | | | e | 3 | 3 | - | 1 | 5 | 90.0 |
| PSWZ X1P | | | | | | ◆ | e | 3 | 2 | - | 1 | 1 | 45.0 |

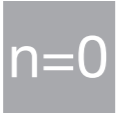

* Value applies for instantaneous (delayed) safety contacts

Selection guide PNOZsigma

| Type | Application | | | | | Performance Level (PL) - EN ISO 13849-1 | Safety Integrity Level (SIL) CL – Claim limit in accordance with IEC 62061 | Output contacts | | | | Universal power supply 48 ... 240 VAC/DC | Housing width in mm |
|-----------|---|---|---|---|---|---|--|-----------------|---|--------------------|---|--|---------------------|
| | | | | | | | | Safety-related | | Not safety-related | | | |
| | | | | | | | | | | | | | |
| PNOZ s1 | ◆ | ◆ | | | | c | 2 | 2 | - | - | 1 | | 12.5 |
| PNOZ s2 | ◆ | ◆ | | | | e | 3 | 3 | - | 1 | 1 | | 17.5 |
| PNOZ s3 | ◆ | ◆ | ◆ | | | e | 3 | 2 | - | - | 1 | | 17.5 |
| PNOZ s4 | ◆ | ◆ | ◆ | | | e | 3 | 3 | - | 1 | 1 | ◆ | 22.5 |
| PNOZ s4.1 | ◆ | ◆ | ◆ | | | e | 3 | 3 | - | 1 | 1 | ◆ | 22.5 |
| PNOZ s5 | ◆ | ◆ | ◆ | | ◆ | e | 3 | 2 | 2 | - | 1 | ◆ | 22.5 |
| PNOZ s6 | | | | ◆ | | EN 574, Type IIIC | e | 3 | - | 1 | 1 | ◆ | 22.5 |
| PNOZ s6.1 | | | | ◆ | | EN 574, Type IIIA | c | 1 | - | 1 | 1 | ◆ | 22.5 |
| PNOZ s7 | Contact expansion | | | | | e | 3 | 4 | - | 1 | - | | 17.5 |
| PNOZ s7.1 | Contact expansion | | | | | e | 3 | 3 | - | - | - | | 17.5 |
| PNOZ s7.2 | Contact expansion | | | | | e | 3 | 4 | - | 1 | - | | 17.5 |
| PNOZ s8 | Contact expansion | | | | | c | 2 | 2 | - | - | 1 | | 12.5 |
| PNOZ s9 | Contact expansion or safe timer relay | | | | ◆ | e | 3 | - | 3 | 1 | - | | 17.5 |
| PNOZ s10 | Contact expansion | | | | | e | 3 | 4 | - | 1 | - | | 45.0 |
| PNOZ s11 | Contact expansion | | | | | e | 3 | 8 | - | 1 | - | | 45.0 |
| PNOZ s20 | Contact expansion | | | | | e | 3 | - | - | - | 3 | | 22.5 |
| PNOZ s22 | Contact expansion for PNOZ s30 and PNOZ mm0.1p/mm0.2p | | | | | e | 3 | 2x3 | - | 2x1 | - | | 22.5 |

Selection guide PNOZsigma

| Type | Application | | | | | Performance Level (PL) - EN ISO 13849-1 | Safety Integrity Level (SIL) CL – Claim limit in accordance with IEC 62061 | Output contacts | | | | Universal power supply 24 ... 240 VAC/DC | Housing width in mm |
|----------|---|---|---|--|--|---|--|---|---|---|---|--|---------------------|
| | | | | | | | | Safety-related | | Not safety-related | | | |
| |  |  |  | | | | |  |  |  |  | | |
| PNOZ s30 | Safe speed and standstill monitor | | | | | e | 3 | 2 | - | 2 | 4 | ◆ | 45.0 |
| | ◆ | ◆ | ◆ | | | | | | | | | | |

| Type | Application | | | | | Performance Level (PL) - EN ISO 13849-1 | Safety Integrity Level (SIL) CL – Claim limit in accordance with IEC 62061 | Semiconductor outputs | | | Universal power supply 24 ... 240 VAC/DC | Housing width in mm |
|----------|---|--|--|--|--|---|--|---|---|--|--|---------------------|
| | | | | | | | | 2-pin | 1-pin | | | |
| |  | | | | | | |  |  | | | |
| PNOZ s50 | Safe brake control | | | | | e | 3 | 2 | 3 | | | 45.0 |
| | ◆ | | | | | | | | | | | |

Safety relays PNOZ X

Safety relays PNOZ X

| Contents | Page |
|--------------|------|
| PNOZ X1P | 12 |
| PNOZ X2P | 23 |
| PNOZ X2.1VP | 41 |
| PNOZ X2.3P | 54 |
| PNOZ X2.7P | 66 |
| PNOZ X2.8P | 88 |
| PNOZ X2.9P | 112 |
| PNOZ X3P | 126 |
| PNOZ X3.10P | 147 |
| PNOZ X7P | 162 |
| PNOZ X8P | 179 |
| PNOZ X9P | 213 |
| PNOZ X10.11P | 237 |
| PNOZ X11P | 251 |
| PNOZ XV1P | 273 |
| PNOZ XV2P | 292 |
| PNOZ XV2.1P | 318 |
| PNOZ XV3P | 345 |
| PNOZ XV3.1P | 372 |
| PZE X4P | 409 |
| PZE X4.1P | 419 |
| PZE X4VP | 435 |
| PZE X4VP4 | 454 |
| PZE X4VP8 | 463 |
| PZE X5P | 472 |
| PZE 9P | 482 |
| PMUT X1P | 500 |
| PSWZ X1P | 519 |

Safety relays PNOZ X PNOZ X1P



Unit features

- ▶ Positive-guided relay outputs:
 - 3 safety contacts (N/O), instantaneous
 - 1 auxiliary contact (N/C), instantaneous
- ▶ Connection options for:
 - E-STOP pushbutton
 - Safety gate limit switch
 - Start button
- ▶ LED display for:
 - Supply voltage
 - Switch status of the safety contacts
- ▶ Plug-in connection terminals (either spring-loaded terminal or screw terminal)
- ▶ See order reference for unit types

Safety relays PNOZ X

PNOZ X1P

Block diagram/terminal configuration

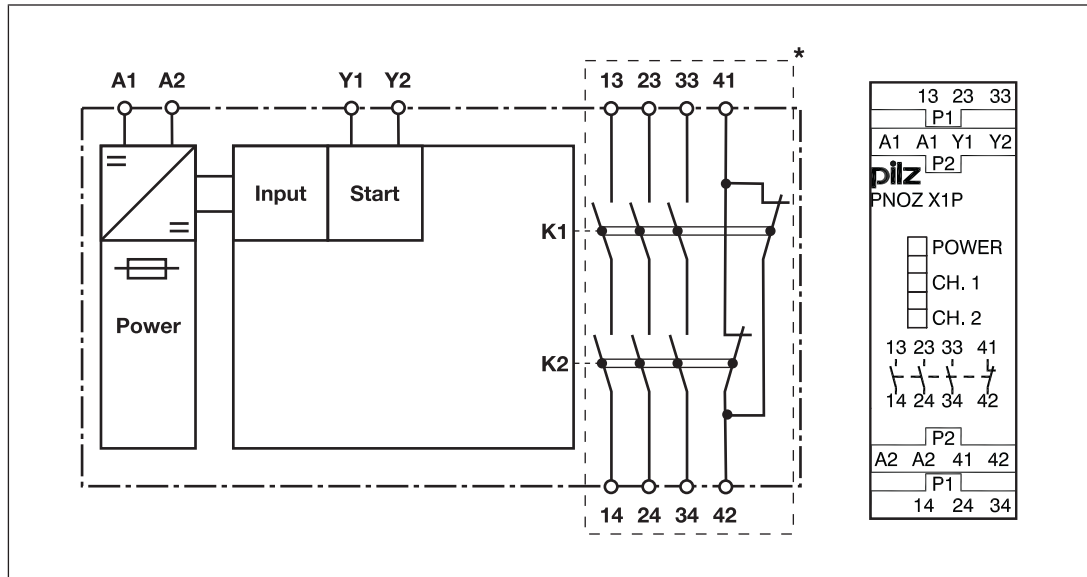

*Insulation between the non-marked area and the relay contacts: Basic insulation (over-voltage category III), Protective separation (overvoltage category II)

Function Description

The safety relay PNOZ X1P provides a safety-oriented interruption of a safety circuit. When the supply voltage is applied via the E-STOP pushbutton, the "POWER" LED is lit. The unit is ready for operation when the start circuit Y1-Y2 is closed.

- ▶ Input circuit is closed (e.g. E-STOP pushbutton not operated):
 - LEDs "CH1" and "CH2" will light.
 - Safety contacts 13-14, 23-24 and 33-34 are closed, auxiliary contact 41-42 is open. The unit is active.
- ▶ Input circuit is opened (e.g. E-STOP pushbutton operated):
 - The LEDs "POWER", "CH1" and "CH2" go out.
 - Safety contacts 13-14, 23-24 and 33-34 are opened redundantly, auxiliary contact 41-42 is closed.

Operating modes

- ▶ Single-channel operation: No redundancy in the input circuit, earth faults in the start and input circuit are detected.
- ▶ Automatic start: Unit is active once the input circuit has been closed.
- ▶ Manual start: Unit is active once the input circuit and the start circuit are closed.
- ▶ Increase in the number of available contacts by connecting contact expander modules or external contactors/relays.

Safety relays PNOZ X PNOZ X1P

Timing diagram

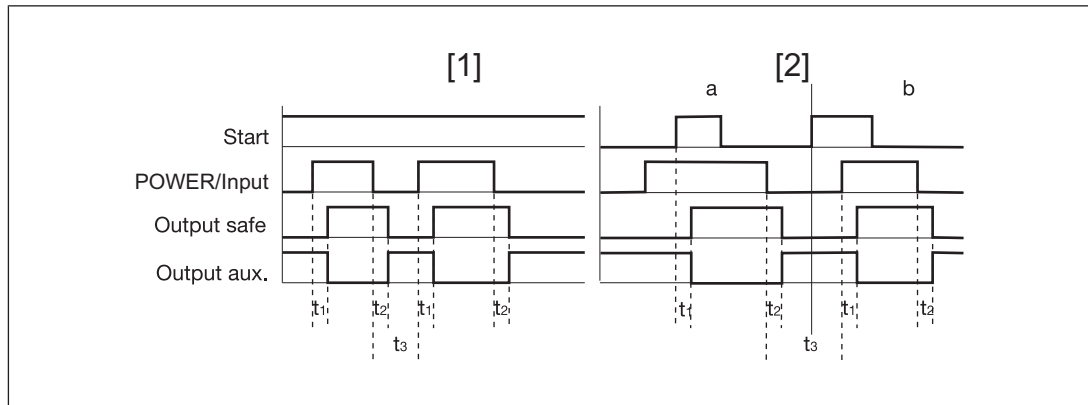

Legend

- ▶ Power/Input: Supply voltage/input circuit
- ▶ Start: Start circuit
- ▶ Output safe: Safety contacts
- ▶ Output aux.: Auxiliary contact
- ▶ [1]: Automatic start
- ▶ [2]: Manual start
- ▶ a: Input circuit closes before start circuit
- ▶ b: Start circuit closes before input circuit
- ▶ t_1 : Switch-on delay
- ▶ t_2 : Delay-on de-energisation
- ▶ t_3 : Recovery time

Installation

- ▶ The unit should be installed in a control cabinet with a protection type of at least IP54.
- ▶ Use the notch on the rear of the unit to attach it to a DIN rail.
- ▶ Ensure the unit is mounted securely on a vertical DIN rail (35 mm) by using a fixing element (e.g. retaining bracket or an end angle).

Safety relays PNOZ X PNOZ X1P

Wiring

Please note:

- ▶ Information given in the "Technical details [📖 17]" must be followed.
- ▶ Outputs 13-14, 23-24, 33-34 are safety contacts; output 41-42 is an auxiliary contact (e.g. for display).
- ▶ Auxiliary contact 41-42 should **not** be used for safety circuits!
- ▶ Do not connect undesignated terminals.
- ▶ To prevent contact welding, a fuse should be connected before the output contacts (see Technical details [📖 17]).
- ▶ Calculation of the max. cable length l_{\max} in the input circuit:

$$l_{\max} = \frac{R_{l_{\max}}}{R_l / \text{km}}$$

$R_{l_{\max}}$ = max. overall cable resistance (see Technical details [📖 17])

R_l / km = cable resistance/km

- ▶ Use copper wire that can withstand 60/75 °C.
- ▶ Sufficient fuse protection must be provided on all output contacts with capacitive and inductive loads.
- ▶ Do not switch low currents using contacts that have been used previously with high currents.
- ▶ The power supply must comply with the regulations for extra low voltages with protective electrical separation (SELV, PELV) in accordance with VDE 0100, Part 410.
- ▶ Ensure the wiring and EMC requirements of IEC 60204-1 are met.

Preparing for operation

| Supply voltage/input circuit | E-STOP | Safety gate |
|------------------------------|--------|-------------|
| 24 VDC | | |

Safety relays PNOZ X PNOZ X1P

| Start circuit | Automatic start | Manual start |
|-----------------------------------|-----------------|--------------|
| E-STOP/safety gate | | |
| Feedback loop | Automatic start | Manual start |
| Contacts from external contactors | | |

Legend

- ▶ S1: E-STOP/safety gate switch
- ▶ S3: Start button
- ▶ : Gate open
- ▶ : Gate closed

Dimensions in mm

* with spring-loaded terminals

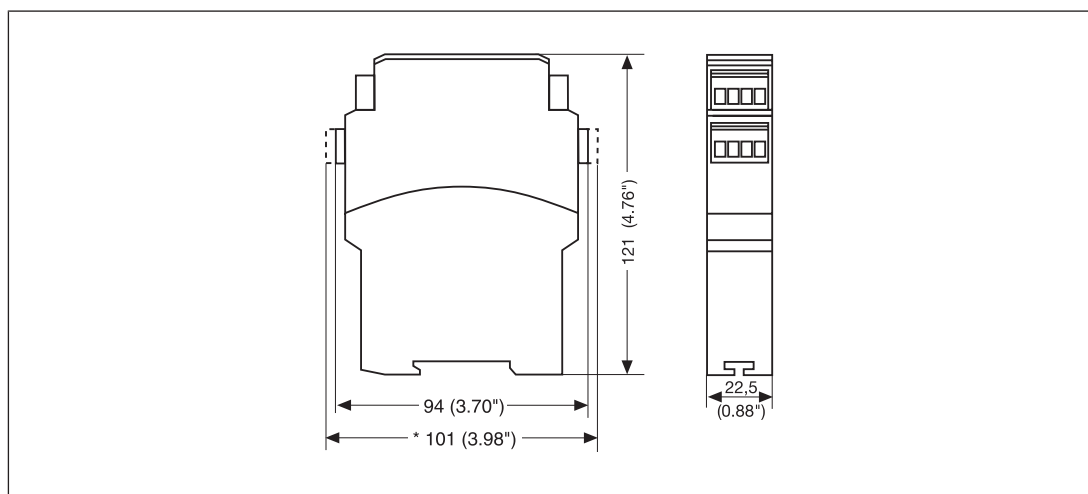

Safety relays PNOZ X PNOZ X1P

Technical details

| General | 777100 | 787100 |
|---|--|--|
| Approvals | CCC, CE, EAC (Eurasian), TÜV, cULus Listed | CCC, CE, EAC (Eurasian), TÜV, cULus Listed |
| Electrical data | 777100 | 787100 |
| Supply voltage | | |
| Voltage | 24 V | 24 V |
| Kind | DC | DC |
| Voltage tolerance | -15 %/+10 % | -15 %/+10 % |
| Output of external power supply (DC) | 1,5 W | 1,5 W |
| Residual ripple DC | 160 % | 160 % |
| Duty cycle | 100 % | 100 % |
| Max. inrush current impulse | | |
| Current pulse, A1 | 1,2 A | 1,2 A |
| Pulse duration, A1 | 2,5 ms | 2,5 ms |
| Inputs | 777100 | 787100 |
| Number | 1 | 1 |
| Voltage at | | |
| Input circuit DC | 24 V | 24 V |
| Start circuit DC | 24 V | 24 V |
| Feedback loop DC | 24 V | 24 V |
| Current at | | |
| Input circuit DC | 45 mA | 45 mA |
| Start circuit DC | 45 mA | 45 mA |
| Feedback loop DC | 45 mA | 45 mA |
| Max. overall cable resistance RI-max | | |
| Single-channel at UB DC | 30 Ohm | 30 Ohm |
| Relay outputs | 777100 | 787100 |
| Number of output contacts | | |
| Safety contacts (N/O), instantaneous | 3 | 3 |
| Auxiliary contacts (N/C) | 1 | 1 |
| Max. short circuit current I _K | 1 kA | 1 kA |
| Utilisation category | | |
| In accordance with the standard | EN 60947-4-1 | EN 60947-4-1 |

Safety relays PNOZ X PNOZ X1P

| Relay outputs | 777100 | 787100 |
|--|-------------------|-------------------|
| Utilisation category of safety contacts | | |
| AC1 at | 240 V | 240 V |
| Min. current | 0,01 A | 0,01 A |
| Max. current | 6 A | 6 A |
| Max. power | 1500 VA | 1500 VA |
| DC1 at | 24 V | 24 V |
| Min. current | 0,01 A | 0,01 A |
| Max. current | 6 A | 6 A |
| Max. power | 150 W | 150 W |
| Utilisation category of auxiliary contacts | | |
| AC1 at | 240 V | 240 V |
| Min. current | 0,01 A | 0,01 A |
| Max. current | 6 A | 6 A |
| Max. power | 1500 VA | 1500 VA |
| DC1 at | 24 V | 24 V |
| Min. current | 0,01 A | 0,01 A |
| Max. current | 6 A | 6 A |
| Max. power | 150 W | 150 W |
| Utilisation category | | |
| In accordance with the standard | EN 60947-5-1 | EN 60947-5-1 |
| Utilisation category of safety contacts | | |
| AC15 at | 230 V | 230 V |
| Max. current | 5 A | 5 A |
| DC13 (6 cycles/min) at | 24 V | 24 V |
| Max. current | 4 A | 4 A |
| Utilisation category of auxiliary contacts | | |
| AC15 at | 230 V | 230 V |
| Max. current | 5 A | 5 A |
| DC13 (6 cycles/min) at | 24 V | 24 V |
| Max. current | 4 A | 4 A |
| Utilisation category in accordance with UL | | |
| Voltage | 240 V AC G. P. | 240 V AC G. P. |
| With current | 6 A | 6 A |
| Voltage | 24 V DC Resistive | 24 V DC Resistive |
| With current | 6 A | 6 A |
| Pilot Duty | B300, R300 | B300, R300 |

Safety relays PNOZ X PNOZ X1P

| Relay outputs | 777100 | 787100 |
|--|--------------------------------------|--------------------------------------|
| External contact fuse protection, safety contacts | | |
| In accordance with the standard | EN 60947-5-1 | EN 60947-5-1 |
| Max. melting integral | 100 A²s | 100 A²s |
| Blow-out fuse, quick | 6 A | 6 A |
| Blow-out fuse, slow | 4 A | 4 A |
| Blow-out fuse, gG | 6 A | 6 A |
| Circuit breaker 24V AC/DC, characteristic B/C | 4 A | 4 A |
| External contact fuse protection, auxiliary contacts | | |
| Max. melting integral | 100 A²s | 100 A²s |
| Blow-out fuse, quick | 6 A | 6 A |
| Blow-out fuse, slow | 4 A | 4 A |
| Blow-out fuse, gG | 6 A | 6 A |
| Circuit breaker 24 V AC/DC, characteristic B/C | 4 A | 4 A |
| Contact material | AgSnO₂ + 0,2 µm Au | AgSnO₂ + 0,2 µm Au |
| Conventional thermal current while loading several contacts | 777100 | 787100 |
| I _{th} per contact at UB DC; AC1: 240 V, DC1: 24 V | | |
| Conv. therm. current with 1 contact | 6 A | 6 A |
| Conv. therm. current with 2 contacts | 6 A | 6 A |
| Conv. therm. current with 3 contacts | 4,5 A | 4,5 A |
| Times | 777100 | 787100 |
| Switch-on delay | | |
| With automatic start typ. | 60 ms | 60 ms |
| With automatic start max. | 120 ms | 120 ms |
| With manual start typ. | 50 ms | 50 ms |
| With manual start max. | 120 ms | 120 ms |
| Delay-on de-energisation | | |
| With E-STOP typ. | 55 ms | 55 ms |
| With E-STOP max. | 90 ms | 90 ms |
| With power failure typ. | 55 ms | 55 ms |
| With power failure max. | 90 ms | 90 ms |
| Recovery time at max. switching frequency 1/s | | |
| After E-STOP | 150 ms | 150 ms |
| After power failure | 150 ms | 150 ms |

Safety relays PNOZ X PNOZ X1P

| Times | 777100 | 787100 |
|--|---|---|
| Supply interruption before de-energisation | 20 ms | 20 ms |
| Environmental data | 777100 | 787100 |
| Climatic suitability | EN 60068-2-78 | EN 60068-2-78 |
| Ambient temperature | | |
| Temperature range | -10 - 55 °C | -10 - 55 °C |
| Storage temperature | | |
| Temperature range | -40 - 85 °C | -40 - 85 °C |
| Climatic suitability | | |
| Humidity | 93 % r. h. at 40 °C | 93 % r. h. at 40 °C |
| Condensation during operation | Not permitted | Not permitted |
| EMC | EN 60947-5-1, EN 61000-6-2, EN 61326-3-1 | EN 60947-5-1, EN 61000-6-2, EN 61326-3-1 |
| Vibration | | |
| In accordance with the standard | EN 60068-2-6 | EN 60068-2-6 |
| Frequency | 10 - 55 Hz | 10 - 55 Hz |
| Amplitude | 0,35 mm | 0,35 mm |
| Airgap creepage | | |
| In accordance with the standard | EN 60947-1 | EN 60947-1 |
| Overvoltage category | III / II | III / II |
| Pollution degree | 2 | 2 |
| Rated insulation voltage | 250 V | 250 V |
| Rated impulse withstand voltage | 4 kV | 4 kV |
| Protection type | | |
| Mounting area (e.g. control cabinet) | IP54 | IP54 |
| Housing | IP40 | IP40 |
| Terminals | IP20 | IP20 |
| Mechanical data | 777100 | 787100 |
| Mounting position | Any | Any |
| Mechanical life | 10,000,000 cycles | 10,000,000 cycles |
| Material | | |
| Bottom | PPO UL 94 V0 | PPO UL 94 V0 |
| Front | ABS UL 94 V0 | ABS UL 94 V0 |
| Top | PPO UL 94 V0 | PPO UL 94 V0 |
| Connection type | Screw terminal | Spring-loaded terminal |
| Mounting type | plug-in | plug-in |

Safety relays PNOZ X PNOZ X1P

| Mechanical data | 777100 | 787100 |
|---|--|---|
| Conductor cross section with screw terminals | | |
| 1 core flexible | 0,25 - 2,5 mm ² , 24 - 12 AWG | – |
| 2 core with the same cross section, flexible with crimp connectors, no plastic sleeve | 0,25 - 1 mm ² , 24 - 16 AWG | – |
| 2 core with the same cross section, flexible without crimp connectors or with TWIN crimp connectors | 0,2 - 1,5 mm ² , 24 - 16 AWG | – |
| Torque setting with screw terminals | 0,5 Nm | – |
| Conductor cross section with spring-loaded terminals: Flexible with/without crimp connector | – | 0,2 - 1,5 mm ² , 24 - 16 AWG |
| Spring-loaded terminals: Terminal points per connection | – | 2 |
| Stripping length with spring-loaded terminals | – | 8 mm |
| Dimensions | | |
| Height | 94 mm | 101 mm |
| Width | 22,5 mm | 22,5 mm |
| Depth | 121 mm | 121 mm |
| Weight | 205 g | 205 g |

Where standards are undated, the 2014-07 latest editions shall apply.

Safety characteristic data

| Operating Mode | EN ISO 13849-1: 2015 | EN ISO 13849-1: 2015 | EN 62061 SIL CL | EN 62061 PFH _D [1/h] | IEC 61511 SIL | IEC 61511 PFD | EN ISO 13849-1: 2015 T _M [year] |
|----------------|----------------------|----------------------|-----------------|---------------------------------|---------------|---------------|--|
| – | PL e | Cat. 4 | SIL CL 3 | 2,31E-09 | SIL 3 | 2,03E-06 | 20 |

All the units used within a safety function must be considered when calculating the safety characteristic data.

Supplementary data

The PFH value depends on the switching frequency and the load on the relay output. If the service life graphs are not accessible, the stated PFH value can be used irrespective of the switching frequency and the load, as the PFH value already considers the relay's B10d value as well as the failure rates of the other components.

Safety relays PNOZ X PNOZ X1P

Service life graph

The service life graphs indicate the number of cycles from which failures due to wear must be expected. The wear is mainly caused by the electrical load; the mechanical load is negligible.

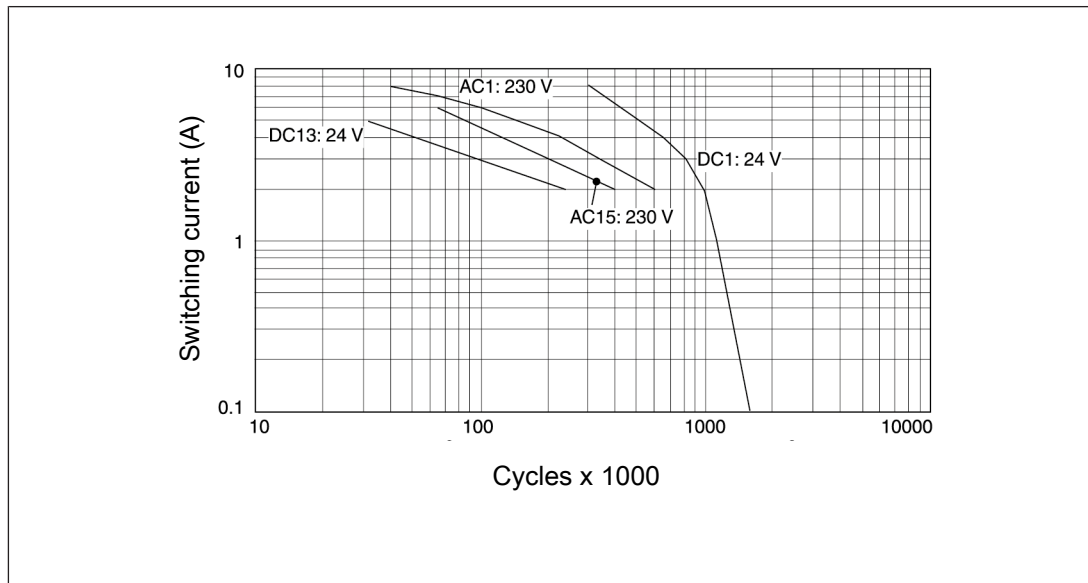

Example

- ▶ Inductive load: 2 A
- ▶ Utilisation category AC15
- ▶ Contact service life: 400 000 cycles

Provided the application to be implemented requires fewer than 400 000 cycles, the PFH value (see Technical details) can be used in the calculation.

To increase the service life, sufficient spark suppression must be provided on all output contacts. With capacitive loads, any power surges that occur must be noted. With DC contacts, use flywheel diodes for spark suppression.

Order reference

| Product type | Features | Connection type | Order no. |
|--------------|----------|-------------------------|-----------|
| PNOZ X1P C | 24 VDC | Spring-loaded terminals | 787 100 |
| PNOZ X1P | 24 VDC | Screw terminals | 777 100 |

Safety relays PNOZ X PNOZ X2P

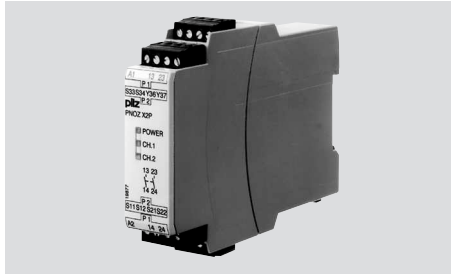

Unit features

- ▶ Positive-guided relay outputs:
 - 2 safety contacts (N/O), instantaneous
- ▶ Connection options for:
 - E-STOP pushbutton
 - Safety gate limit switch
 - Start button
- ▶ LED display for:
 - Supply voltage
 - Switch status of the safety contacts
- ▶ Plug-in connection terminals (either spring-loaded terminal or screw terminal)
- ▶ See order reference for unit types

Safety relays PNOZ X PNOZ X2P

Block diagram/terminal configuration

Type: 24 V AC/DC

▶ U_B : 24 VAC/DC; Order no. 777303, 787303

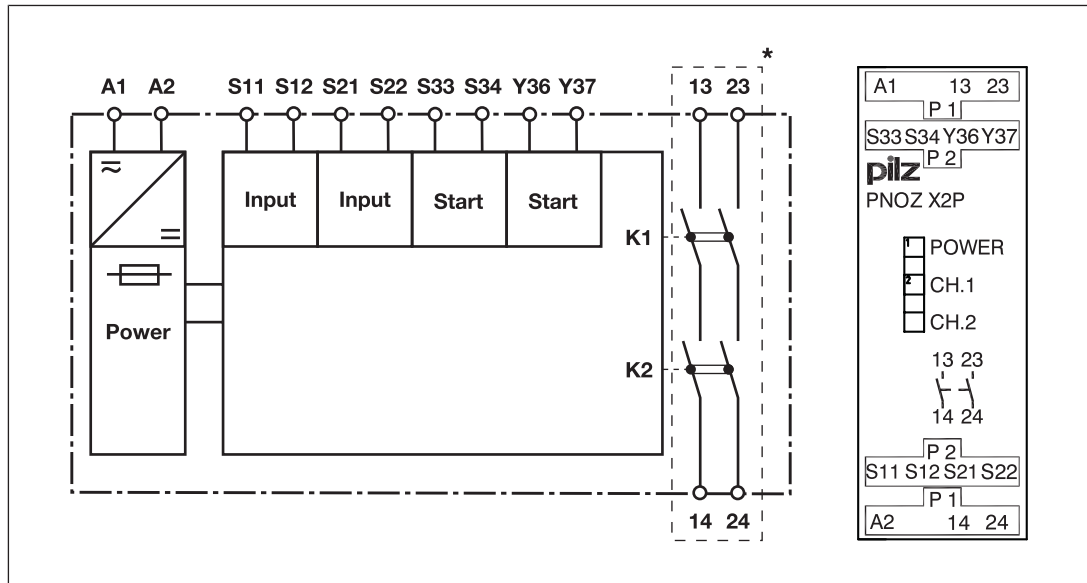

*Insulation between the non-marked area and the relay contacts: Basic insulation (over-voltage category III), Protective separation (overvoltage category II)

Safety relays PNOZ X PNOZ X2P

Type: 48-240 V AC/DC

- ▶ U_B : 48-240 VAC/DC; Order no. 777307, 787307

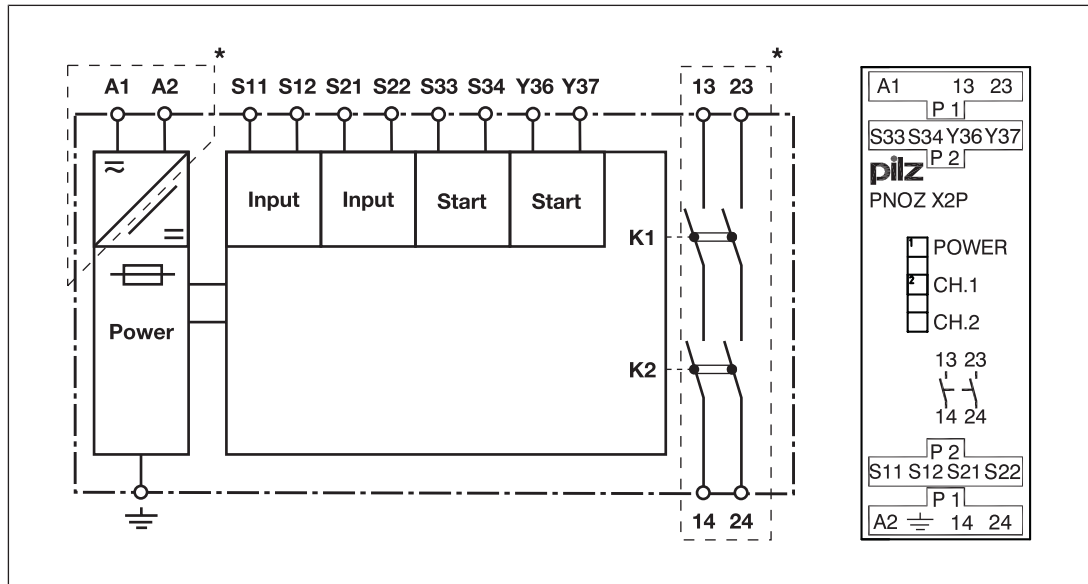

*Insulation between the non-marked area and the relay contacts: Basic insulation (over-voltage category III), Protective separation (overvoltage category II)

Function Description

The safety relay PNOZ X2P provides a safety-oriented interruption of a safety circuit. When supply voltage is supplied the "POWER" LED is lit. The unit is ready for operation when the start circuit S33-S34 is closed.

- ▶ Input circuit is closed (e.g. E-STOP pushbutton not operated):
 - Safety contacts 13-14 and 23-24 are closed, the unit is active.
 - The LEDs "CH.1" and "CH.2" are lit.
- ▶ Input circuit is opened (e.g. E-STOP pushbutton operated):
 - Safety contacts 13-14 and 23-24 are redundantly opened.
 - The LEDs "CH.1" and "CH.2" go out.

Operating modes

- ▶ Single-channel operation (only 24 VAC/DC units): No redundancy in the input circuit, earth faults in the start and input circuit are detected.
- ▶ Dual-channel operation with detection of shorts across contacts: Redundant input circuit, PNOZ X2P detects
 - earth faults in the start and input circuit,
 - short circuits in the input circuit,
 - shorts across contacts in the input circuit.

Safety relays PNOZ X PNOZ X2P

- ▶ Automatic start: Unit is active once the input circuit has been closed.
- ▶ Manual start: Unit is active once the input circuit and the start circuit are closed.
- ▶ Monitored start: Unit is active once the input circuit is closed and once the start circuit is closed after the waiting period has elapsed (see [Technical details \[30\]](#)).
- ▶ Increase in the number of available contacts by connecting contact expander modules or external contactors/relays.

Timing diagram

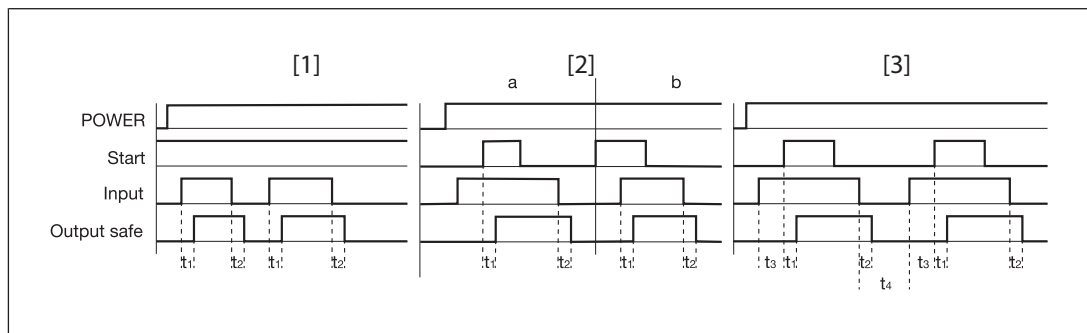

Legend

- ▶ Power: Supply voltage
- ▶ Start: Start circuit
- ▶ Input: Input circuit
- ▶ Output safe: Safety contacts
- ▶ [1]: Automatic start
- ▶ [2]: Manual start
- ▶ [3]: Monitored start
- ▶ a: Input circuit closes before start circuit
- ▶ b: Start circuit closes before input circuit
- ▶ t₁: Switch-on delay
- ▶ t₂: Delay-on de-energisation
- ▶ t₃: Waiting period with a monitored start
- ▶ t₄: Recovery time

Installation

- ▶ The unit should be installed in a control cabinet with a protection type of at least IP54.
- ▶ Use the notch on the rear of the unit to attach it to a DIN rail.
- ▶ Ensure the unit is mounted securely on a vertical DIN rail (35 mm) by using a fixing element (e.g. retaining bracket or an end angle).

Safety relays PNOZ X PNOZ X2P

Wiring

Please note:

- ▶ Information given in the "Technical details [30]" must be followed.
- ▶ The outputs 13-14, 23-24 are safety contacts.
- ▶ Do not connect undesignated terminals.
- ▶ To prevent contact welding, a fuse should be connected before the output contacts (see Technical details [30]).
- ▶ Calculation of the max. cable length l_{\max} in the input circuit:

$$l_{\max} = \frac{R_{l_{\max}}}{R_l / \text{km}}$$

$R_{l_{\max}}$ = max. overall cable resistance (see Technical details [30])

R_l / km = cable resistance/km

- ▶ Use copper wire that can withstand 60/75 °C.
- ▶ Sufficient fuse protection must be provided on all output contacts with capacitive and inductive loads.
- ▶ Do not switch low currents using contacts that have been used previously with high currents.
- ▶ When connecting magnetically operated, reed proximity switches, ensure that the max. peak inrush current (on the input circuit) does not overload the proximity switch.
- ▶ Ensure the wiring and EMC requirements of IEC 60204-1 are met.
- ▶ On 24 VAC/DC units:
The power supply must comply with the regulations for extra low voltages with safe electrical separation (SELV, PELV) in accordance with VDE 0100, Part 410.

Important for detection of shorts across contacts:

As this function for detecting shorts across contacts is not failsafe, it is tested by Pilz during the final control check. If there is a danger of exceeding the cable runs, we recommend the following test after the installation of the device:

1. Unit ready for operation (output contacts closed)
2. Short circuit the test terminals S12, S22 for detecting shorts across the inputs.
3. The unit's fuse must be triggered and the output contacts must open. Cable lengths in the scale of the maximum length can delay the fuse triggering for up to 2 minutes.
4. Reset the fuse: remove the short circuit and switch off the supply voltage for approx. 1 minute.

Safety relays PNOZ X PNOZ X2P

Preparing for operation

| Supply voltage | AC | DC |
|-------------------------------|---------------------------------------|---|
| $U_B = 24 \text{ VAC/DC}$ | | |
| $U_B = 48-240 \text{ VAC/DC}$ | | |
| Input circuit | Single-channel (only U_B 24 VAC/DC) | Dual-channel (with detection of shorts across contacts) |
| E-STOP | | |
| Safety gate | | |

Safety relays PNOZ X PNOZ X2P

| Start circuit | Single-channel (only U _B 24 VAC/DC) | Dual-channel (with detection of shorts across contacts) |
|-----------------------------------|--|---|
| Automatic start | | |
| Manual start | | |
| Monitored start | | |
| Feedback loop | Automatic start | Monitored start |
| Contacts from external contactors | | |

Legend

- ▶ S1/S2: E-STOP/safety gate switch
- ▶ S3: Reset button
- ▶ ↑↑: Switch operated
- ▶ : Gate open
- ▶ : Gate closed

Safety relays PNOZ X PNOZ X2P

Dimensions in mm

* with spring-loaded terminals

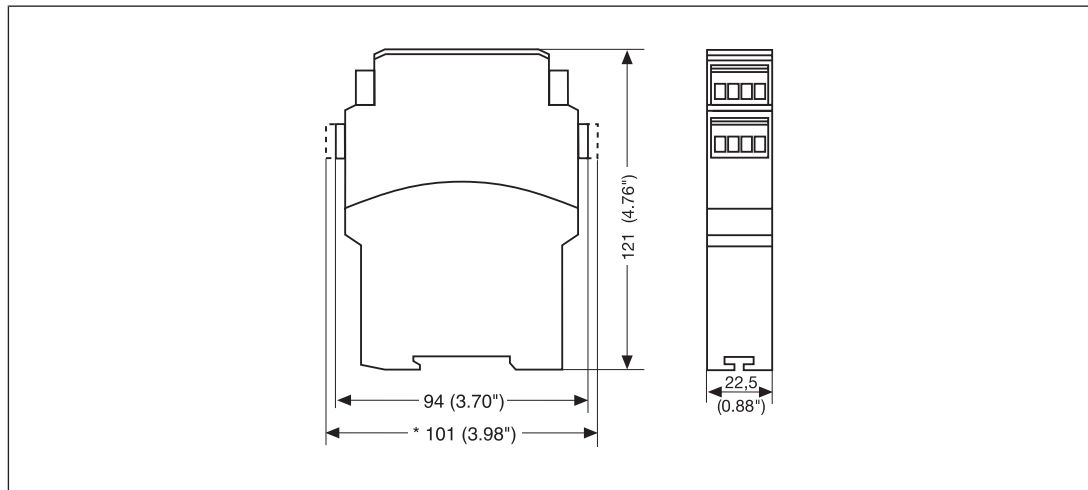

Technical details

Order no. 777303 – 777307

See below for more order numbers

| General | 777303 | 777307 |
|--------------------------------------|--|--|
| Approvals | CCC, CE, EAC (Eurasian), TÜV, cULus Listed | CCC, CE, EAC (Eurasian), TÜV, cULus Listed |
| Electrical data | 777303 | 777307 |
| Supply voltage | | |
| Voltage | 24 V | 48 - 240 V |
| Kind | AC/DC | AC/DC |
| Voltage tolerance | -15 %/+10 % | -15 %/+10 % |
| Output of external power supply (AC) | 4,5 VA | 3,5 VA |
| Output of external power supply (DC) | 2 W | 1 W |
| Frequency range AC | 50 - 60 Hz | 50 - 60 Hz |
| Residual ripple DC | 160 % | 160 % |
| Duty cycle | 100 % | 100 % |
| Max. inrush current impulse | | |
| Current pulse, A1 | 1,7 A | – |
| Pulse duration, A1 | 1,5 ms | – |
| Inputs | 777303 | 777307 |
| Number | 2 | 2 |

Safety relays PNOZ X PNOZ X2P

| Inputs | 777303 | 777307 |
|--|---------------------|---------------------|
| Voltage at | | |
| Input circuit DC | 24 V | 24 V |
| Start circuit DC | 24 V | 24 V |
| Feedback loop DC | 24 V | 24 V |
| Current at | | |
| Input circuit DC | 25 mA | 15 mA |
| Start circuit DC | 50 mA | 25 mA |
| Feedback loop DC | 50 mA | 25 mA |
| Min. input resistance at power-on | 21 Ohm | 19 Ohm |
| Max. overall cable resistance RI-max | | |
| Single-channel at UB DC | 50 Ohm | – |
| Single-channel at UB AC | 150 Ohm | – |
| Dual-channel with detection of shorts across contacts at UB DC | 15 Ohm | 100 Ohm |
| Dual-channel with detection of shorts across contacts at UB AC | 30 Ohm | 100 Ohm |
| Relay outputs | 777303 | 777307 |
| Number of output contacts | | |
| Safety contacts (N/O), instantaneous | 2 | 2 |
| Max. short circuit current IK | 1 kA | 1 kA |
| Utilisation category | | |
| In accordance with the standard | EN 60947-4-1 | EN 60947-4-1 |
| Utilisation category of safety contacts | | |
| AC1 at | 240 V | 240 V |
| Min. current | 0,01 A | 0,01 A |
| Max. current | 6 A | 6 A |
| Max. power | 1500 VA | 1500 VA |
| DC1 at | 24 V | 24 V |
| Min. current | 0,01 A | 0,01 A |
| Max. current | 6 A | 6 A |
| Max. power | 150 W | 150 W |
| Utilisation category | | |
| In accordance with the standard | EN 60947-5-1 | EN 60947-5-1 |
| Utilisation category of safety contacts | | |
| AC15 at | 230 V | 230 V |
| Max. current | 5 A | 5 A |
| DC13 (6 cycles/min) at | 24 V | 24 V |
| Max. current | 4 A | 4 A |

Safety relays PNOZ X PNOZ X2P

| Relay outputs | 777303 | 777307 |
|---|--------------------------------|--------------------------------|
| Utilisation category in accordance with UL | | |
| Voltage | 240 V AC G. P. | 240 V AC G. P. |
| With current | 6 A | 6 A |
| Voltage | 24 V DC Resistive | 24 V DC Resistive |
| With current | 6 A | 6 A |
| Pilot Duty | C300, R300 | B300, R300 |
| External contact fuse protection, safety contacts | | |
| In accordance with the standard | EN 60947-5-1 | EN 60947-5-1 |
| Max. melting integral | 240 A ² s | 100 A ² s |
| Blow-out fuse, quick | 6 A | 6 A |
| Blow-out fuse, slow | 4 A | 4 A |
| Blow-out fuse, gG | 6 A | 6 A |
| Circuit breaker 24V AC/DC, characteristic B/C | 4 A | 4 A |
| Conventional thermal current | 6 A | 6 A |
| Contact material | AgSnO ₂ + 0,2 µm Au | AgSnO ₂ + 0,2 µm Au |
| Times | 777303 | 777307 |
| Switch-on delay | | |
| With automatic start typ. | 60 ms | 120 ms |
| With automatic start max. | 90 ms | 150 ms |
| With automatic start after power on typ. | 60 ms | 130 ms |
| With automatic start after power on max. | 100 ms | 160 ms |
| With manual start typ. | 40 ms | 40 ms |
| With manual start max. | 90 ms | 150 ms |
| With monitored start typ. | 35 ms | 35 ms |
| With monitored start max. | 50 ms | 50 ms |
| Delay-on de-energisation | | |
| With E-STOP typ. | 15 ms | 15 ms |
| With E-STOP max. | 30 ms | 30 ms |
| With power failure typ. | 70 ms | 40 ms |
| With power failure max. | 110 ms | 70 ms |
| With power failure typ. UB 240 V – | | 320 ms |
| With power failure max. UB 240 V | – | 500 ms |
| Recovery time at max. switching frequency 1/s | | |
| After E-STOP | 50 ms | 50 ms |
| After power failure | 150 ms | 550 ms |

Safety relays PNOZ X PNOZ X2P

| Times | 777303 | 777307 |
|--|--|--|
| Waiting period with a monitored start | 180 ms | 180 ms |
| Min. start pulse duration with a monitored start | 30 ms | 30 ms |
| Supply interruption before de-energisation | 20 ms | 20 ms |
| Simultaneity, channel 1 and 2 max. | ∞ | ∞ |
| Environmental data | 777303 | 777307 |
| Climatic suitability | EN 60068-2-78 | EN 60068-2-78 |
| Ambient temperature | | |
| Temperature range | -10 - 55 °C | -10 - 55 °C |
| Storage temperature | | |
| Temperature range | -40 - 85 °C | -40 - 85 °C |
| Climatic suitability | | |
| Humidity | 93 % r. h. at 40 °C | 93 % r. h. at 40 °C |
| Condensation during operation | Not permitted | Not permitted |
| EMC | EN 60947-5-1, EN 61000-6-2, EN 61326-3-1 | EN 60947-5-1, EN 61000-6-2, EN 61000-6-3, EN 61326-3-1 |
| Vibration | | |
| In accordance with the standard | EN 60068-2-6 | EN 60068-2-6 |
| Frequency | 10 - 55 Hz | 10 - 55 Hz |
| Amplitude | 0,35 mm | 0,35 mm |
| Airgap creepage | | |
| In accordance with the standard | EN 60947-1 | EN 60947-1 |
| Overvoltage category | III / II | III / II |
| Pollution degree | 2 | 2 |
| Rated insulation voltage | 250 V | 250 V |
| Rated impulse withstand voltage | 4 kV | 4 kV |
| Protection type | | |
| Mounting area (e.g. control cabinet) | IP54 | IP54 |
| Housing | IP40 | IP40 |
| Terminals | IP20 | IP20 |
| Mechanical data | 777303 | 777307 |
| Mounting position | Any | Any |
| Mechanical life | 10,000,000 cycles | 10,000,000 cycles |
| Material | | |
| Bottom | PPO UL 94 V0 | PPO UL 94 V0 |
| Front | ABS UL 94 V0 | ABS UL 94 V0 |
| Top | PPO UL 94 V0 | PPO UL 94 V0 |
| Connection type | Screw terminal | Screw terminal |

Safety relays PNOZ X PNOZ X2P

| Mechanical data | 777303 | 777307 |
|---|--|--|
| Mounting type | plug-in | plug-in |
| Conductor cross section with screw terminals | | |
| 1 core flexible | 0,25 - 2,5 mm ² , 24 - 12 AWG | 0,25 - 2,5 mm ² , 24 - 12 AWG |
| 2 core with the same cross section, flexible with crimp connectors, no plastic sleeve | 0,25 - 1 mm ² , 24 - 16 AWG | 0,25 - 1 mm ² , 24 - 16 AWG |
| 2 core with the same cross section, flexible without crimp connectors or with TWIN crimp connectors | 0,2 - 1,5 mm ² , 24 - 16 AWG | 0,2 - 1,5 mm ² , 24 - 16 AWG |
| Torque setting with screw terminals | 0,5 Nm | 0,5 Nm |
| Dimensions | | |
| Height | 94 mm | 94 mm |
| Width | 22,5 mm | 22,5 mm |
| Depth | 121 mm | 121 mm |
| Weight | 200 g | 200 g |

Where standards are undated, the 2014-07 latest editions shall apply.

Order no. 787303 – 787307

| General | 787303 | 787307 |
|--------------------------------------|--|--|
| Approvals | CCC, CE, EAC (Eurasian), TÜV, cULus Listed | CCC, CE, EAC (Eurasian), TÜV, cULus Listed |
| Electrical data | 787303 | 787307 |
| Supply voltage | | |
| Voltage | 24 V | 48 - 240 V |
| Kind | AC/DC | AC/DC |
| Voltage tolerance | -15 %/+10 % | -15 %/+10 % |
| Output of external power supply (AC) | 4,5 VA | 3,5 VA |
| Output of external power supply (DC) | 2 W | 1 W |
| Frequency range AC | 50 - 60 Hz | 50 - 60 Hz |
| Residual ripple DC | 160 % | 160 % |
| Duty cycle | 100 % | 100 % |
| Max. inrush current impulse | | |
| Current pulse, A1 | 1,7 A | – |
| Pulse duration, A1 | 1,5 ms | – |
| Inputs | 787303 | 787307 |
| Number | 2 | 2 |

Safety relays PNOZ X PNOZ X2P

| Inputs | 787303 | 787307 |
|--|---------------------|---------------------|
| Voltage at | | |
| Input circuit DC | 24 V | 24 V |
| Start circuit DC | 24 V | 24 V |
| Feedback loop DC | 24 V | 24 V |
| Current at | | |
| Input circuit DC | 25 mA | 15 mA |
| Start circuit DC | 50 mA | 25 mA |
| Feedback loop DC | 50 mA | 25 mA |
| Min. input resistance at power-on | 21 Ohm | 19 Ohm |
| Max. overall cable resistance RI-max | | |
| Single-channel at UB DC | 50 Ohm | – |
| Single-channel at UB AC | 150 Ohm | – |
| Dual-channel with detection of shorts across contacts at UB DC | 15 Ohm | 100 Ohm |
| Dual-channel with detection of shorts across contacts at UB AC | 30 Ohm | 100 Ohm |
| Relay outputs | 787303 | 787307 |
| Number of output contacts | | |
| Safety contacts (N/O), instantaneous | 2 | 2 |
| Max. short circuit current IK | 1 kA | 1 kA |
| Utilisation category | | |
| In accordance with the standard | EN 60947-4-1 | EN 60947-4-1 |
| Utilisation category of safety contacts | | |
| AC1 at | 240 V | 240 V |
| Min. current | 0,01 A | 0,01 A |
| Max. current | 6 A | 6 A |
| Max. power | 1500 VA | 1500 VA |
| DC1 at | 24 V | 24 V |
| Min. current | 0,01 A | 0,01 A |
| Max. current | 6 A | 6 A |
| Max. power | 150 W | 150 W |
| Utilisation category | | |
| In accordance with the standard | EN 60947-5-1 | EN 60947-5-1 |
| Utilisation category of safety contacts | | |
| AC15 at | 230 V | 230 V |
| Max. current | 5 A | 5 A |
| DC13 (6 cycles/min) at | 24 V | 24 V |
| Max. current | 4 A | 4 A |

Safety relays PNOZ X PNOZ X2P

| Relay outputs | 787303 | 787307 |
|---|--------------------------------|--------------------------------|
| Utilisation category in accordance with UL | | |
| Voltage | 240 V AC G. P. | 240 V AC G. P. |
| With current | 6 A | 6 A |
| Voltage | 24 V DC Resistive | 24 V DC Resistive |
| With current | 6 A | 6 A |
| Pilot Duty | C300, R300 | B300, R300 |
| External contact fuse protection, safety contacts | | |
| In accordance with the standard | EN 60947-5-1 | EN 60947-5-1 |
| Max. melting integral | 240 A ² s | 100 A ² s |
| Blow-out fuse, quick | 6 A | 6 A |
| Blow-out fuse, slow | 4 A | 4 A |
| Blow-out fuse, gG | 6 A | 6 A |
| Circuit breaker 24V AC/DC, characteristic B/C | 4 A | 4 A |
| Conventional thermal current | 6 A | 6 A |
| Contact material | AgSnO ₂ + 0,2 µm Au | AgSnO ₂ + 0,2 µm Au |
| Times | 787303 | 787307 |
| Switch-on delay | | |
| With automatic start typ. | 60 ms | 120 ms |
| With automatic start max. | 90 ms | 150 ms |
| With automatic start after power on typ. | 60 ms | 130 ms |
| With automatic start after power on max. | 100 ms | 160 ms |
| With manual start typ. | 40 ms | 40 ms |
| With manual start max. | 90 ms | 150 ms |
| With monitored start typ. | 35 ms | 35 ms |
| With monitored start max. | 50 ms | 50 ms |
| Delay-on de-energisation | | |
| With E-STOP typ. | 15 ms | 15 ms |
| With E-STOP max. | 30 ms | 30 ms |
| With power failure typ. | 70 ms | 40 ms |
| With power failure max. | 110 ms | 70 ms |
| With power failure typ. UB 240 V – | | 320 ms |
| With power failure max. UB 240 V | – | 500 ms |
| Recovery time at max. switching frequency 1/s | | |
| After E-STOP | 50 ms | 50 ms |
| After power failure | 150 ms | 550 ms |

Safety relays PNOZ X PNOZ X2P

| Times | 787303 | 787307 |
|--|--|--|
| Waiting period with a monitored start | 180 ms | 180 ms |
| Min. start pulse duration with a monitored start | 30 ms | 30 ms |
| Supply interruption before de-energisation | 20 ms | 20 ms |
| Simultaneity, channel 1 and 2 max. | ∞ | ∞ |
| Environmental data | 787303 | 787307 |
| Climatic suitability | EN 60068-2-78 | EN 60068-2-78 |
| Ambient temperature | | |
| Temperature range | -10 - 55 °C | -10 - 55 °C |
| Storage temperature | | |
| Temperature range | -40 - 85 °C | -40 - 85 °C |
| Climatic suitability | | |
| Humidity | 93 % r. h. at 40 °C | 93 % r. h. at 40 °C |
| Condensation during operation | Not permitted | Not permitted |
| EMC | EN 60947-5-1, EN 61000-6-2, EN 61326-3-1 | EN 60947-5-1, EN 61000-6-2, EN 61000-6-3, EN 61326-3-1 |
| Vibration | | |
| In accordance with the standard | EN 60068-2-6 | EN 60068-2-6 |
| Frequency | 10 - 55 Hz | 10 - 55 Hz |
| Amplitude | 0,35 mm | 0,35 mm |
| Airgap creepage | | |
| In accordance with the standard | EN 60947-1 | EN 60947-1 |
| Overvoltage category | III / II | III / II |
| Pollution degree | 2 | 2 |
| Rated insulation voltage | 250 V | 250 V |
| Rated impulse withstand voltage | 4 kV | 4 kV |
| Protection type | | |
| Mounting area (e.g. control cabinet) | IP54 | IP54 |
| Housing | IP40 | IP40 |
| Terminals | IP20 | IP20 |
| Mechanical data | 787303 | 787307 |
| Mounting position | Any | Any |
| Mechanical life | 10,000,000 cycles | 10,000,000 cycles |
| Material | | |
| Bottom | PPO UL 94 V0 | PPO UL 94 V0 |
| Front | ABS UL 94 V0 | ABS UL 94 V0 |
| Top | PPO UL 94 V0 | PPO UL 94 V0 |
| Connection type | Spring-loaded terminal | Spring-loaded terminal |

Safety relays PNOZ X PNOZ X2P

| Mechanical data | 787303 | 787307 |
|---|---|---|
| Mounting type | plug-in | plug-in |
| Conductor cross section with spring-loaded terminals: Flexible with/without crimp connector | 0,2 - 1,5 mm ² , 24 - 16 AWG | 0,2 - 1,5 mm ² , 24 - 16 AWG |
| Spring-loaded terminals: Terminal points per connection | 2 | 2 |
| Stripping length with spring-loaded terminals | 8 mm | 8 mm |
| Dimensions | | |
| Height | 101 mm | 101 mm |
| Width | 22,5 mm | 22,5 mm |
| Depth | 121 mm | 121 mm |
| Weight | 200 g | 200 g |

Where standards are undated, the 2014-07 latest editions shall apply.

Safety characteristic data

| Operating Mode | EN ISO 13849-1: 2015 | EN ISO 13849-1: 2015 | EN 62061 SIL CL | EN 62061 PFH _D [1/h] | IEC 61511 SIL | IEC 61511 PFD | EN ISO 13849-1: 2015 T _M [year] |
|----------------|----------------------|----------------------|-----------------|---------------------------------|---------------|---------------|--|
| | PL | Category | | | | | |
| – | PL e | Cat. 4 | SIL CL 3 | 2,31E-09 | SIL 3 | 2,03E-06 | 20 |

All the units used within a safety function must be considered when calculating the safety characteristic data.

Supplementary data

The PFH value depends on the switching frequency and the load on the relay output. If the service life graphs are not accessible, the stated PFH value can be used irrespective of the switching frequency and the load, as the PFH value already considers the relay's B10d value as well as the failure rates of the other components.

Safety relays PNOZ X PNOZ X2P

Service life graph

The service life graphs indicate the number of cycles from which failures due to wear must be expected. The wear is mainly caused by the electrical load; the mechanical load is negligible.

Unit types with UB 24 VAC/DC

- ▶ U_B : 24 VAC/DC; Order no. 777303, 787303

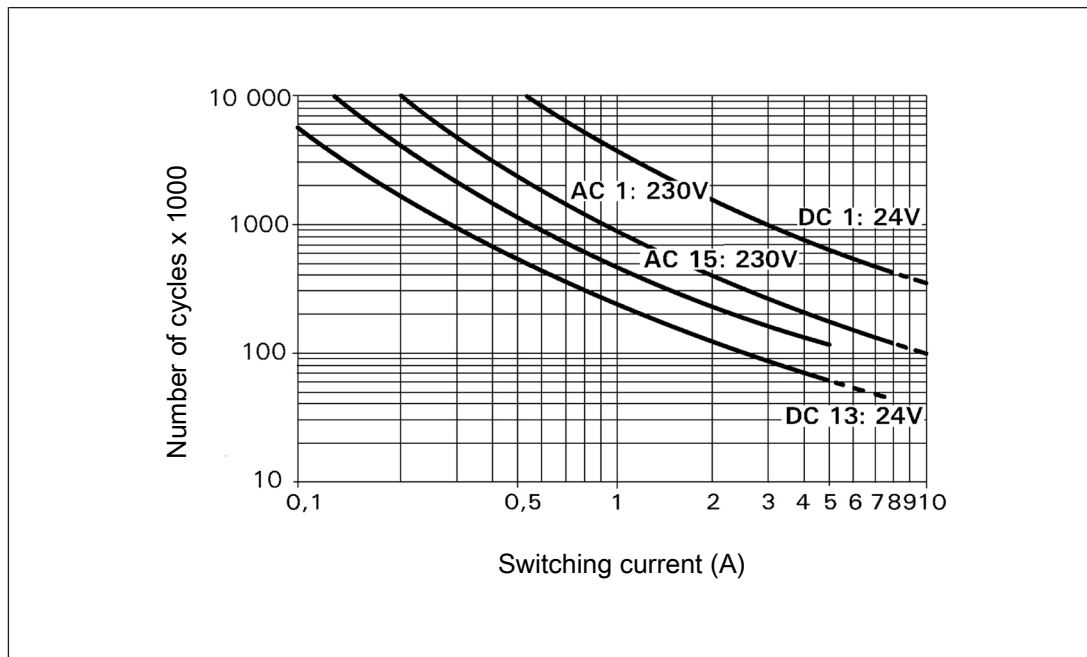

Example

- ▶ Inductive load: 0.2 A
- ▶ Utilisation category: AC15
- ▶ Contact service life: 4 000 000 cycles

Provided the application to be implemented requires fewer than 4 000 000 cycles, the PFH value (see Technical details) can be used in the calculation.

To increase the service life, sufficient spark suppression must be provided on all output contacts. With capacitive loads, any power surges that occur must be noted. With DC contactors, use flywheel diodes for spark suppression.

Safety relays PNOZ X PNOZ X2P

Unit types with UB 48-240 VAC/DC

- ▶ U_B : 48-240 VAC/DC; Order no. 777307, 787307

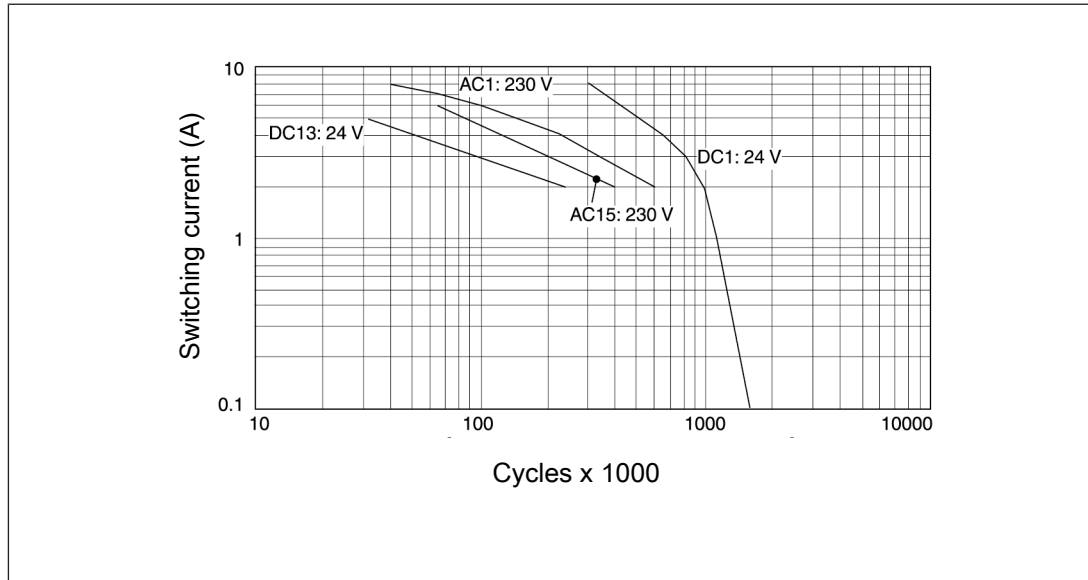

Example

- ▶ Inductive load: 2 A
- ▶ Utilisation category AC15
- ▶ Contact service life: 400 000 cycles

Provided the application to be implemented requires fewer than 400 000 cycles, the PFH value (see Technical details) can be used in the calculation.

To increase the service life, sufficient spark suppression must be provided on all output contacts. With capacitive loads, any power surges that occur must be noted. With DC contactors, use flywheel diodes for spark suppression.

Order reference

| Product type | Features | Connection type | Order no. |
|--------------|---------------|-------------------------|-----------|
| PNOZ X2P | 24 VAC/DC | Screw terminals | 777 303 |
| PNOZ X2P C | 24 VAC/DC | Spring-loaded terminals | 787 303 |
| PNOZ X2P | 48-240 VAC/DC | Screw terminals | 777 307 |
| PNOZ X2P C | 48-240 VAC/DC | Spring-loaded terminals | 787 307 |

Safety relays PNOZ X PNOZ X2.1VP

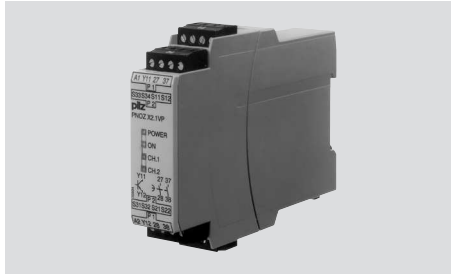

Unit features

- ▶ Positive-guided relay outputs:
 - 2 safety contacts (N/O), delay-on de-energisation
- ▶ 1 semiconductor output for variable frequency inverter
- ▶ Connection options for:
 - E-STOP pushbutton
 - Safety gate limit switch
 - Start button
- ▶ LED display for:
 - Supply voltage
 - Switch state of the safety contacts
 - State of semiconductor output
- ▶ Semiconductor output signals:
 - Switching status of the input circuit
- ▶ Plug-in connection terminals (either spring-loaded terminal or screw terminal)
- ▶ See order reference for unit types

Safety relays PNOZ X PNOZ X2.1VP

Block diagram/terminal configuration

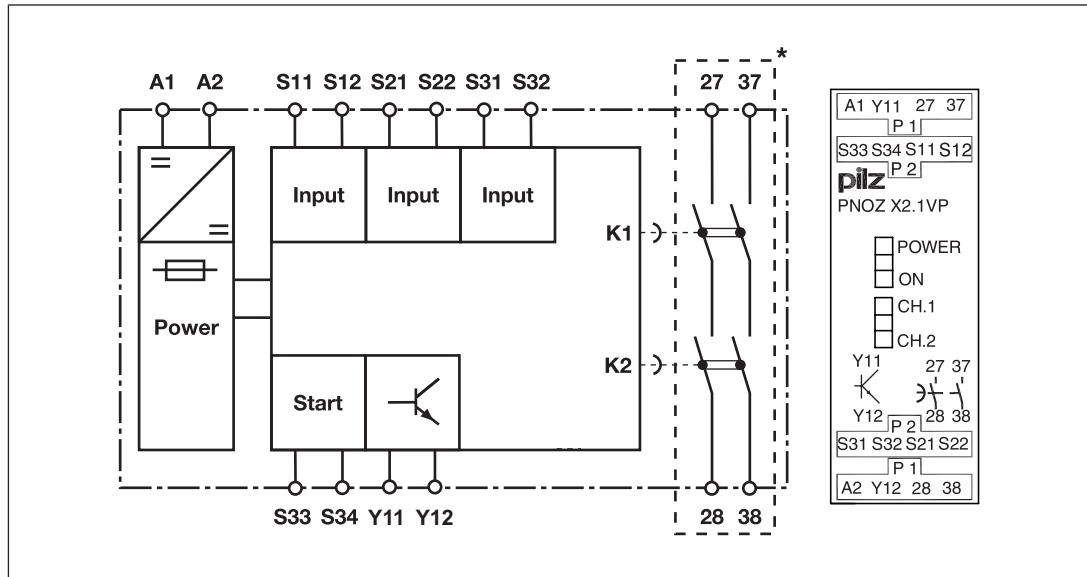

*Insulation between the non-marked area and the relay contacts: Basic insulation (over-voltage category III), Protective separation (overvoltage category II)

Function Description

The safety relay PNOZ X2.1VP provides a safety-oriented interruption of a safety circuit. When supply voltage is supplied the "POWER" LED is lit. The unit is ready for operation when the start circuit S33-S34 is closed.

- ▶ Input circuit is closed (e.g. E-STOP pushbutton not operated):
 - The LEDs "CH.1" and "CH.2" are lit.
 - Safety contacts 27-28 and 37-38 are closed. The unit is active.
 - The semiconductor output Y11-Y12 is enabled.
 - The "ON" LED is lit.
- ▶ Input circuit is opened (e.g. E-STOP pushbutton operated):
 - The semiconductor output Y11-Y12 is disabled instantaneously.
 - The "ON" LED goes out.
 - Safety contacts 27-28 and 37-38 are opened redundantly after the delay time has elapsed.
 - The LEDs "CH.1" and "CH.2" go out.

Safety relays PNOZ X PNOZ X2.1VP

Operating modes

- ▶ Single-channel operation: No redundancy in the input circuit, earth faults in the start and input circuit are detected.
- ▶ Dual-channel operation with detection of shorts across contacts: Redundant input circuit, PNOZ X2.1VP detects
 - earth faults in the start and input circuit,
 - short circuits in the input circuit,
 - shorts across contacts in the input circuit.
- ▶ Automatic start: Unit is active once the input circuit has been closed.
- ▶ Manual start: Unit is active once the input circuit and the start circuit are closed.
- ▶ Increase in the number of available contacts by connecting contact expander modules or external contactors/relays.

Timing diagram

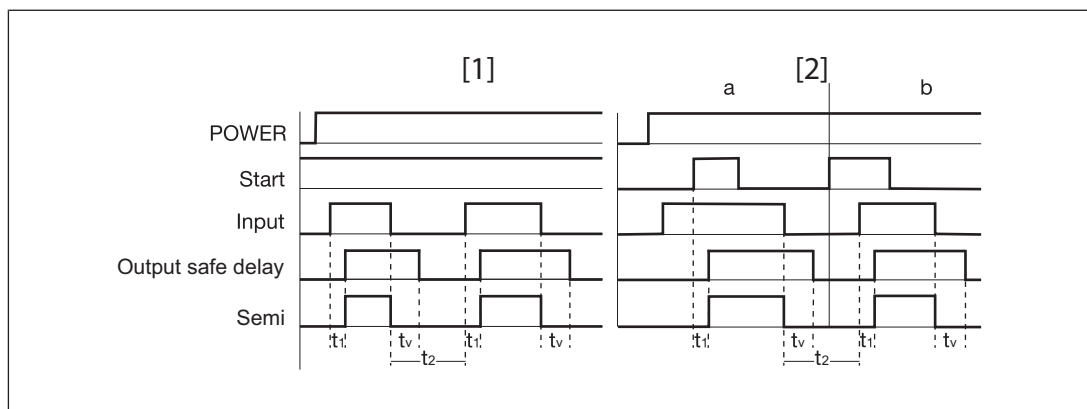

Legend

- ▶ Power: Supply voltage
- ▶ Start: Start circuit
- ▶ Input: Input circuit
- ▶ Output safe delay: Safety contacts, delayed
- ▶ Semi: Semiconductor output
- ▶ [1]: Automatic start
- ▶ [2]: Manual start
- ▶ a: Input circuit closes before start circuit
- ▶ b: Start circuit closes before input circuit
- ▶ t_1 : Switch-on delay
- ▶ t_2 : Recovery time
- ▶ t_v : Delay time

Safety relays PNOZ X PNOZ X2.1VP

Installation

- ▶ The unit should be installed in a control cabinet with a protection type of at least IP54.
- ▶ Use the notch on the rear of the unit to attach it to a DIN rail.
- ▶ Ensure the unit is mounted securely on a vertical DIN rail (35 mm) by using a fixing element (e.g. retaining bracket or an end angle).

Wiring

Please note:

- ▶ Information given in the "[Technical details \[48\]](#)" must be followed.
- ▶ Outputs 27-28, 37-38 are delay-on de-energisation safety contacts.
- ▶ Semiconductor output Y11-Y12 should **not** be used for safety circuits!
- ▶ To prevent contact welding, a fuse should be connected before the output contacts (see [Technical details \[48\]](#)).
- ▶ Calculation of the max. cable length l_{\max} in the input circuit:

$$l_{\max} = \frac{R_{l_{\max}}}{R_l / \text{km}}$$

$R_{l_{\max}}$ = max. overall cable resistance (see [Technical details \[48\]](#))

R_l / km = cable resistance/km

- ▶ Use copper wire that can withstand 60/75 °C.
- ▶ Do not switch low currents using contacts that have been used previously with high currents.
- ▶ Sufficient fuse protection must be provided on all output contacts with capacitive and inductive loads.
- ▶ The power supply must comply with the regulations for extra low voltages with protective electrical separation (SELV, PELV) in accordance with VDE 0100, Part 410.
- ▶ Ensure the wiring and EMC requirements of IEC 60204-1 are met.

Important for detection of shorts across contacts:

As this function for detecting shorts across contacts is not failsafe, it is tested by Pilz during the final control check. If there is a danger of exceeding the cable runs, we recommend the following test after the installation of the device:

1. Unit ready for operation (output contacts closed)
2. Short circuit the test terminals S12, S22 for detecting shorts across the inputs.
3. The unit's fuse must be triggered and the output contacts must open. Cable lengths in the scale of the maximum length can delay the fuse triggering for up to 2 minutes.
4. Reset the fuse: remove the short circuit and switch off the supply voltage for approx. 1 minute.

Safety relays PNOZ X PNOZ X2.1VP

Preparing for operation

| Supply voltage | AC | DC |
|---|----------------|--------------|
| | | |
| Input circuit | Single-channel | Dual-channel |
| E-STOP without detection of shorts across contacts | | |
| E-STOP with detection of shorts across contacts | | |
| Safety gate without detection of shorts across contacts | | |
| Safety gate with detection of shorts across contacts | | |

| Start circuit | Automatic start | Manual start |
|---------------|-----------------|--------------|
| | | |

Safety relays PNOZ X PNOZ X2.1VP

| Feedback loop | Automatic start | Manual start |
|-----------------------------------|---|--------------------------------------|
| Contacts from external contactors | | |
| Semiconductor output | Low level at the input of the driven unit | Fault: High level of the driven unit |
| After opening the input circuit | | |

Legend

- ▶ S1/S2: E-STOP/safety gate switch
- ▶ S3: Reset button
- ▶ ⤴: Switch operated
- ▶ : Gate open
- ▶ : Gate closed

Safety relays PNOZ X PNOZ X2.1VP

Application example

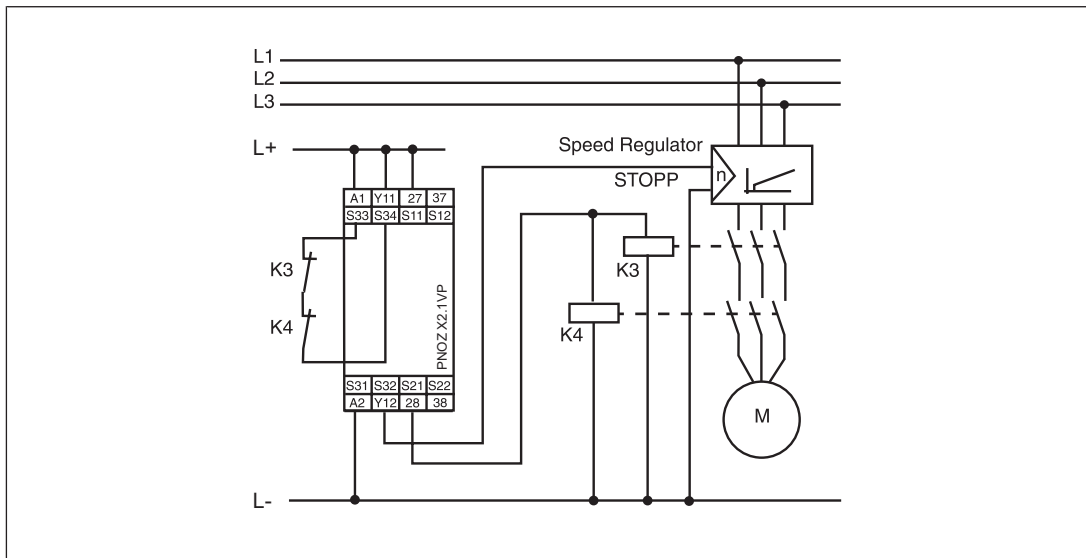
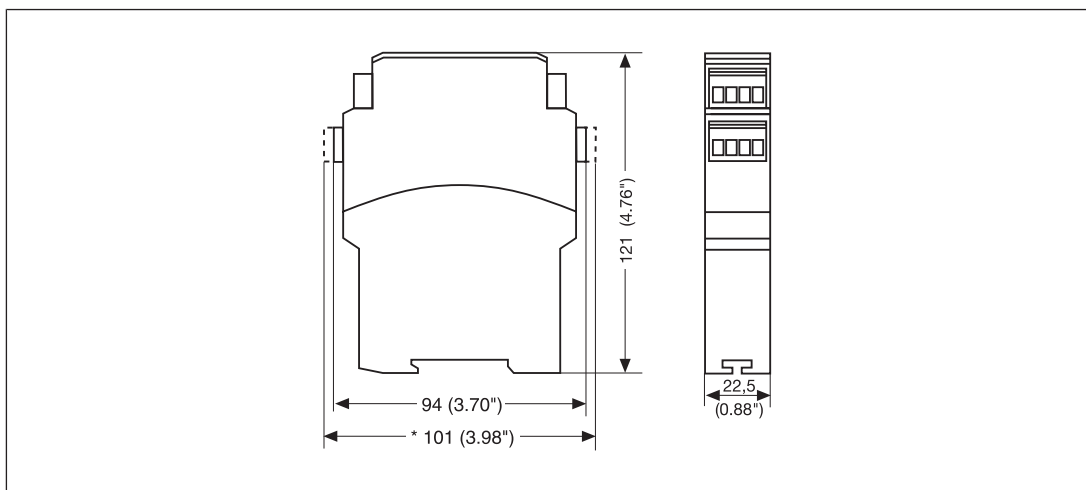

Fig.: Variable frequency inverter with semiconductor output

Dimensions in mm

* with spring-loaded terminals



Safety relays PNOZ X PNOZ X2.1VP

Technical details

| General | 777600 | 787600 |
|--|--|--|
| Approvals | CCC, CE, EAC (Eurasian), TÜV, cULus Listed | CCC, CE, EAC (Eurasian), TÜV, cULus Listed |
| Electrical data | 777600 | 787600 |
| Supply voltage | | |
| Voltage | 24 V | 24 V |
| Kind | DC | DC |
| Voltage tolerance | -15 %/+10 % | -15 %/+10 % |
| Output of external power supply (DC) | 1,5 W | 1,5 W |
| Residual ripple DC | 20 % | 20 % |
| Duty cycle | 100 % | 100 % |
| Max. inrush current impulse | | |
| Current pulse, A1 | 1,7 A | 1,7 A |
| Pulse duration, A1 | 1,5 ms | 1,5 ms |
| Inputs | 777600 | 787600 |
| Number | 2 | 2 |
| Voltage at | | |
| Input circuit DC | 24 V | 24 V |
| Start circuit DC | 24 V | 24 V |
| Feedback loop DC | 24 V | 24 V |
| Current at | | |
| Input circuit DC | 25 mA | 25 mA |
| Start circuit DC | 50 mA | 50 mA |
| Feedback loop DC | 50 mA | 50 mA |
| Max. overall cable resistance RI-max | | |
| Single-channel at UB DC | 40 Ohm | 40 Ohm |
| Dual-channel with detection of shorts across contacts at UB DC | 20 Ohm | 20 Ohm |
| Semiconductor outputs | 777600 | 787600 |
| Number | 1 | 1 |
| Voltage | 24 V | 24 V |
| Current | 100 mA | 100 mA |
| External supply voltage | 24 V | 24 V |
| Voltage tolerance | -20 %/+20 % | -20 %/+20 % |
| Relay outputs | 777600 | 787600 |
| Number of output contacts | | |
| Safety contacts (N/O), delayed | 2 | 2 |
| Max. short circuit current IK | 1 kA | 1 kA |

Safety relays PNOZ X PNOZ X2.1VP

| Relay outputs | 777600 | 787600 |
|---|--------------------------------------|--------------------------------------|
| Utilisation category | | |
| In accordance with the standard | EN 60947-4-1 | EN 60947-4-1 |
| Utilisation category of safety contacts delayed | | |
| AC1 at | 240 V | 240 V |
| Min. current | 0,01 A | 0,01 A |
| Max. current | 6 A | 6 A |
| Max. power | 1500 VA | 1500 VA |
| DC1 at | 24 V | 24 V |
| Min. current | 0,01 A | 0,01 A |
| Max. current | 6 A | 6 A |
| Max. power | 150 W | 150 W |
| Utilisation category | | |
| In accordance with the standard | EN 60947-5-1 | EN 60947-5-1 |
| Utilisation category of safety contacts delayed | | |
| AC15 at | 230 V | 230 V |
| Max. current | 5 A | 5 A |
| DC13 (6 cycles/min) at | 24 V | 24 V |
| Max. current | 4 A | 4 A |
| Utilisation category in accordance with UL | | |
| Voltage | 240 V AC G. P. | 240 V AC G. P. |
| With current | 6 A | 6 A |
| Voltage | 24 V DC Resistive | 24 V DC Resistive |
| With current | 6 A | 6 A |
| Pilot Duty | B300, R300 | B300, R300 |
| External contact fuse protection, safety contacts | | |
| In accordance with the standard | EN 60947-5-1 | EN 60947-5-1 |
| Max. melting integral | 100 A²s | 100 A²s |
| Blow-out fuse, quick | 6 A | 6 A |
| Blow-out fuse, slow | 4 A | 4 A |
| Blow-out fuse, gG | 6 A | 6 A |
| Circuit breaker 24V AC/DC, characteristic B/C | 4 A | 4 A |
| Conventional thermal current | 6 A | 6 A |
| Contact material | AgSnO₂ + 0,2 µm Au | AgSnO₂ + 0,2 µm Au |

Safety relays PNOZ X PNOZ X2.1VP

| Times | 777600 | 787600 |
|---|--|--|
| Switch-on delay | | |
| With automatic start typ. | 100 ms | 100 ms |
| With automatic start max. | 210 ms | 210 ms |
| With manual start typ. | 35 ms | 35 ms |
| With manual start max. | 210 ms | 210 ms |
| Delay-on de-energisation | | |
| With power failure typ. | 1100 ms | 1100 ms |
| With power failure max. | 1500 ms | 1500 ms |
| Recovery time at max. switching frequency 1/s | | |
| After E-STOP | 1550 ms | 1550 ms |
| After power failure | 1550 ms | 1550 ms |
| Delay time tv | 0,75 s | 0,75 s |
| Time accuracy | -30 %/+100 % | -30 %/+100 % |
| Supply interruption before de-energisation | 10 ms | 10 ms |
| Simultaneity, channel 1 and 2 max. | ∞ | ∞ |
| Environmental data | 777600 | 787600 |
| Climatic suitability | EN 60068-2-78 | EN 60068-2-78 |
| Ambient temperature | | |
| Temperature range | -10 - 55 °C | -10 - 55 °C |
| Storage temperature | | |
| Temperature range | -40 - 85 °C | -40 - 85 °C |
| Climatic suitability | | |
| Humidity | 93 % r. h. at 40 °C | 93 % r. h. at 40 °C |
| Condensation during operation | Not permitted | Not permitted |
| EMC | EN 60947-5-1, EN 61000-6-2, EN 61326-3-1 | EN 60947-5-1, EN 61000-6-2, EN 61326-3-1 |
| Vibration | | |
| In accordance with the standard | EN 60068-2-6 | EN 60068-2-6 |
| Frequency | 10 - 55 Hz | 10 - 55 Hz |
| Amplitude | 0,35 mm | 0,35 mm |
| Airgap creepage | | |
| In accordance with the standard | EN 60947-1 | EN 60947-1 |
| Overvoltage category | III / II | III / II |
| Pollution degree | 2 | 2 |
| Rated insulation voltage | 250 V | 250 V |
| Rated impulse withstand voltage | 4 kV | 4 kV |

Safety relays PNOZ X PNOZ X2.1VP

| Environmental data | 777600 | 787600 |
|---|---|--|
| Protection type | | |
| Mounting area (e.g. control cabinet) | IP54 | IP54 |
| Housing | IP40 | IP40 |
| Terminals | IP20 | IP20 |
| Mechanical data | 777600 | 787600 |
| Mounting position | Any | Any |
| Mechanical life | 10,000,000 cycles | 10,000,000 cycles |
| Material | | |
| Bottom | PPO UL 94 V0 | PPO UL 94 V0 |
| Front | ABS UL 94 V0 | ABS UL 94 V0 |
| Top | PPO UL 94 V0 | PPO UL 94 V0 |
| Connection type | Screw terminal | Spring-loaded terminal |
| Mounting type | plug-in | plug-in |
| Conductor cross section with screw terminals | | |
| 1 core flexible | 0,25 - 2,5 mm², 24 - 12 AWG | – |
| 2 core with the same cross section, flexible with crimp connectors, no plastic sleeve | 0,25 - 1 mm², 24 - 16 AWG | – |
| 2 core with the same cross section, flexible without crimp connectors or with TWIN crimp connectors | 0,2 - 1,5 mm², 24 - 16 AWG | – |
| Torque setting with screw terminals | 0,5 Nm | – |
| Conductor cross section with spring-loaded terminals: Flexible with/without crimp connector | – | 0,2 - 1,5 mm², 24 - 16 AWG |
| Spring-loaded terminals: Terminal points per connection | – | 2 |
| Stripping length with spring-loaded terminals | – | 8 mm |
| Dimensions | | |
| Height | 94 mm | 101 mm |
| Width | 22,5 mm | 22,5 mm |
| Depth | 121 mm | 121 mm |
| Weight | 200 g | 200 g |

Where standards are undated, the 2014-07 latest editions shall apply.

Safety relays PNOZ X PNOZ X2.1VP

Safety characteristic data

| Operating Mode | EN ISO 13849-1: 2015 PL | EN ISO 13849-1: 2015 Category | EN 62061 SIL CL | EN 62061 PFH _D [1/h] | IEC 61511 SIL | IEC 61511 PFD | EN ISO 13849-1: 2015 T _M [year] |
|--------------------------------|----------------------------|----------------------------------|--------------------|------------------------------------|------------------|------------------|---|
| Safety contacts, delayed <30 s | PL d | Cat. 3 | SIL CL 3 | 2,64E-09 | SIL 3 | 1,26E-05 | 20 |

All the units used within a safety function must be considered when calculating the safety characteristic data.

Supplementary data

The PFH value depends on the switching frequency and the load on the relay output. If the service life graphs are not accessible, the stated PFH value can be used irrespective of the switching frequency and the load, as the PFH value already considers the relay's B10d value as well as the failure rates of the other components.

Safety relays PNOZ X PNOZ X2.1VP

Service life graph

The service life graphs indicate the number of cycles from which failures due to wear must be expected. The wear is mainly caused by the electrical load; the mechanical load is negligible.

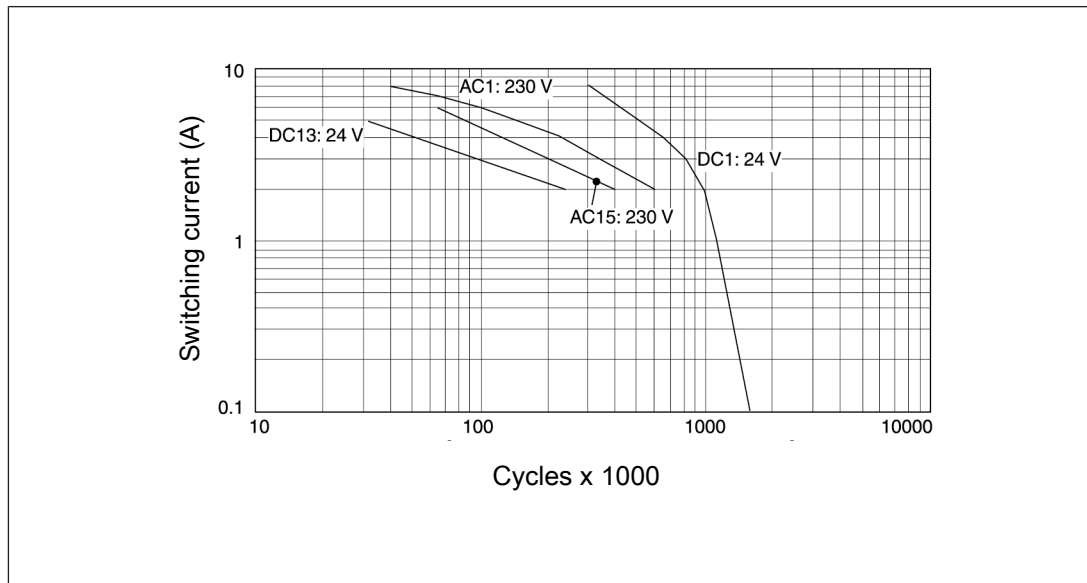

Example

- ▶ Inductive load: 2 A
- ▶ Utilisation category AC15
- ▶ Contact service life: 400 000 cycles

Provided the application to be implemented requires fewer than 400 000 cycles, the PFH value (see Technical details) can be used in the calculation.

To increase the service life, sufficient spark suppression must be provided on all output contacts. With capacitive loads, any power surges that occur must be noted. With DC contacts, use flywheel diodes for spark suppression.

Order reference

| Product type | Features | Connection type | Order no. |
|---------------|----------|-------------------------|-----------|
| PNOZ X2.1VP C | 24 VDC | Spring-loaded terminals | 787 600 |
| PNOZ X2.1VP | 24 VDC | Screw terminals | 777 600 |

Safety relays PNOZ X PNOZ X2.3P



Unit features

- ▶ Positive-guided relay outputs:
 - 3 safety contacts (N/O), instantaneous
- ▶ Connection options for:
 - E-STOP pushbutton
 - Safety gate limit switch
 - Start button
- ▶ LED display for:
 - Supply voltage
 - Switch status of the safety contacts
- ▶ Plug-in connection terminals (either spring-loaded terminal or screw terminal)
- ▶ See order reference for unit types

Safety relays PNOZ X PNOZ X2.3P

Block diagram/terminal configuration

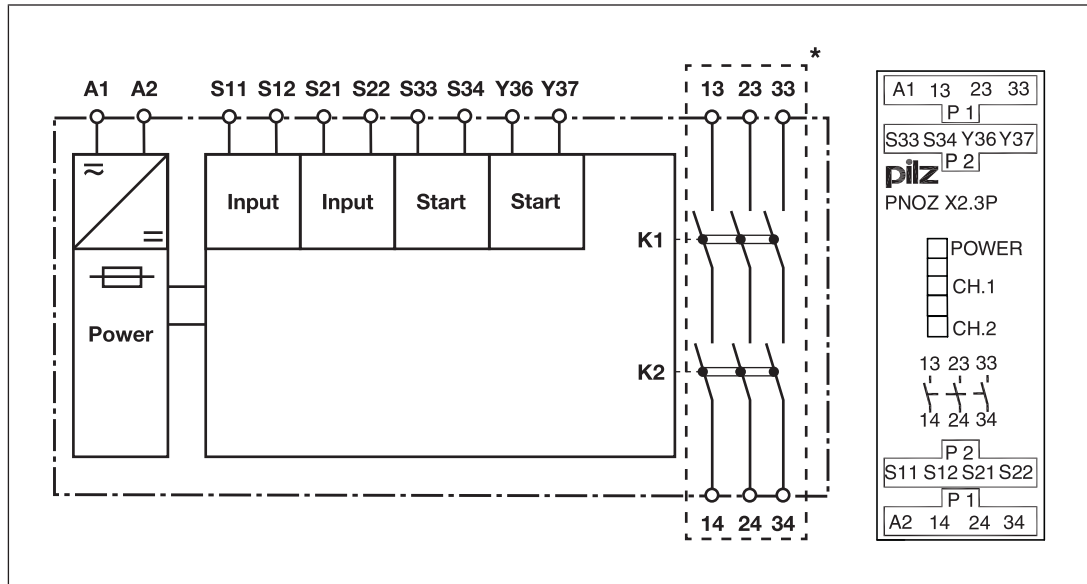

*Insulation between the non-marked area and the relay contacts: Basic insulation (over-voltage category III), Protective separation (overvoltage category II)

Function Description

The safety relay PNOZ X2.3P provides a safety-oriented interruption of a safety circuit. When supply voltage is supplied the "POWER" LED is lit. The unit is ready for operation when the start circuit S33-S34 is closed.

- ▶ Input circuit is closed (e.g. E-STOP pushbutton not operated):
 - Safety contacts 13-14, 23-24 and 33-34 are closed, the unit is active.
 - LEDs "CH1" and "CH2" will light.
- ▶ Input circuit is opened (e.g. E-STOP pushbutton operated):
 - Safety contacts 13-14, 23-24 and 33-34 are opened redundantly.
 - LEDs "CH1" and "CH2" go out.

Operating modes

- ▶ Single-channel operation: No redundancy in the input circuit, earth faults in the start and input circuit are detected.
- ▶ Dual-channel operation with detection of shorts across contacts: Redundant input circuit, PNOZ X2.3P detects
 - earth faults in the start and input circuit,
 - short circuits in the input circuit,
 - shorts across contacts in the input circuit.
- ▶ Automatic start: Unit is active once the input circuit has been closed.

Safety relays PNOZ X PNOZ X2.3P

- ▶ Manual start: Unit is active once the input circuit and the start circuit are closed.
- ▶ Monitored start: Unit is active once the input circuit is closed and once the start circuit is closed after the waiting period has elapsed (see [Technical details](#) [60]).
- ▶ Increase in the number of available contacts by connecting contact expander modules or external contactors/relays.

Timing diagram

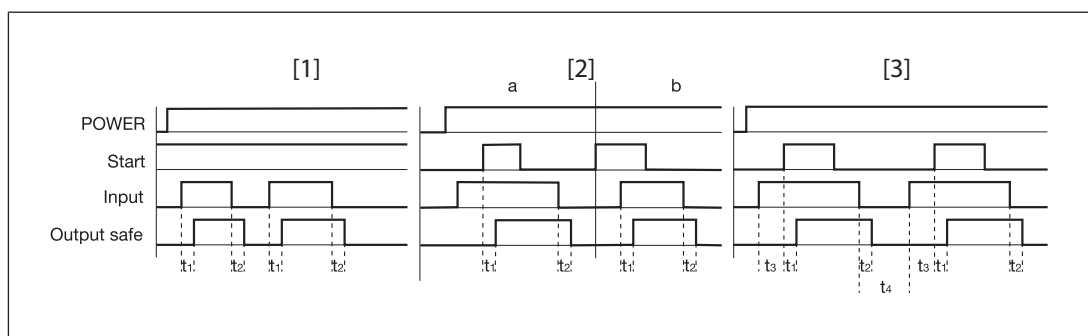

Legend

- ▶ Power: Supply voltage
- ▶ Start: Start circuit
- ▶ Input: Input circuit
- ▶ Output safe: Safety contacts
- ▶ [1]: Automatic start
- ▶ [2]: Manual start
- ▶ [3]: Monitored start
- ▶ a: Input circuit closes before start circuit
- ▶ b: Start circuit closes before input circuit
- ▶ t_1 : Switch-on delay
- ▶ t_2 : Delay-on de-energisation
- ▶ t_3 : Waiting period with a monitored start
- ▶ t_4 : Recovery time

Installation

- ▶ The unit should be installed in a control cabinet with a protection type of at least IP54.
- ▶ Use the notch on the rear of the unit to attach it to a DIN rail.
- ▶ Ensure the unit is mounted securely on a vertical DIN rail (35 mm) by using a fixing element (e.g. retaining bracket or an end angle).

Safety relays PNOZ X PNOZ X2.3P

Wiring

Please note:

- ▶ Information given in the "Technical details [60]" must be followed.
- ▶ The output contacts 13-14, 23-24, 33-34 are safety contacts.
- ▶ To prevent contact welding, a fuse should be connected before the output contacts (see Technical details [60]).
- ▶ Calculation of the max. cable length l_{\max} in the input circuit:

$$l_{\max} = \frac{R_{l_{\max}}}{R_i / \text{km}}$$

$R_{l_{\max}}$ = max. overall cable resistance (see Technical details [60])

R_i / km = cable resistance/km

- ▶ Use copper wire that can withstand 60/75 °C.
- ▶ Sufficient fuse protection must be provided on all output contacts with capacitive and inductive loads.
- ▶ Do not switch low currents using contacts that have been used previously with high currents.
- ▶ When connecting magnetically operated, reed proximity switches, ensure that the max. peak inrush current (on the input circuit) does not overload the proximity switch.
- ▶ Ensure the wiring and EMC requirements of IEC 60204-1 are met.
- ▶ The power supply must comply with the regulations for extra low voltages with protective electrical separation (SELV, PELV) in accordance with VDE 0100, Part 410.

Important for detection of shorts across contacts:

As this function for detecting shorts across contacts is not failsafe, it is tested by Pilz during the final control check. If there is a danger of exceeding the cable runs, we recommend the following test after the installation of the device:

1. Unit ready for operation (output contacts closed)
2. Short circuit the test terminals S12, S22 for detecting shorts across the inputs.
3. The unit's fuse must be triggered and the output contacts must open. Cable lengths in the scale of the maximum length can delay the fuse triggering for up to 2 minutes.
4. Reset the fuse: remove the short circuit and switch off the supply voltage for approx. 1 minute.

Safety relays PNOZ X PNOZ X2.3P

Preparing for operation

| Supply voltage | AC | DC |
|-----------------|----------------|---|
| | | |
| Input circuit | Single-channel | Dual-channel (with detection of shorts across contacts) |
| E-STOP | | |
| Safety gate | | |
| Start circuit | Single-channel | Dual-channel (with detection of shorts across contacts) |
| Automatic start | | |
| Manual start | | |
| Monitored start | | |

Safety relays PNOZ X PNOZ X2.3P

| Feedback loop | Automatic start | Monitored start |
|-----------------------------------|-----------------|-----------------|
| Contacts from external contactors | | |

Legend

- ▶ S1/S2: E-STOP/safety gate switch
- ▶ S3: Reset button
- ▶ ↑↑: Switch operated
- ▶ : Gate open
- ▶ : Gate closed

Dimensions in mm

* with spring-loaded terminals

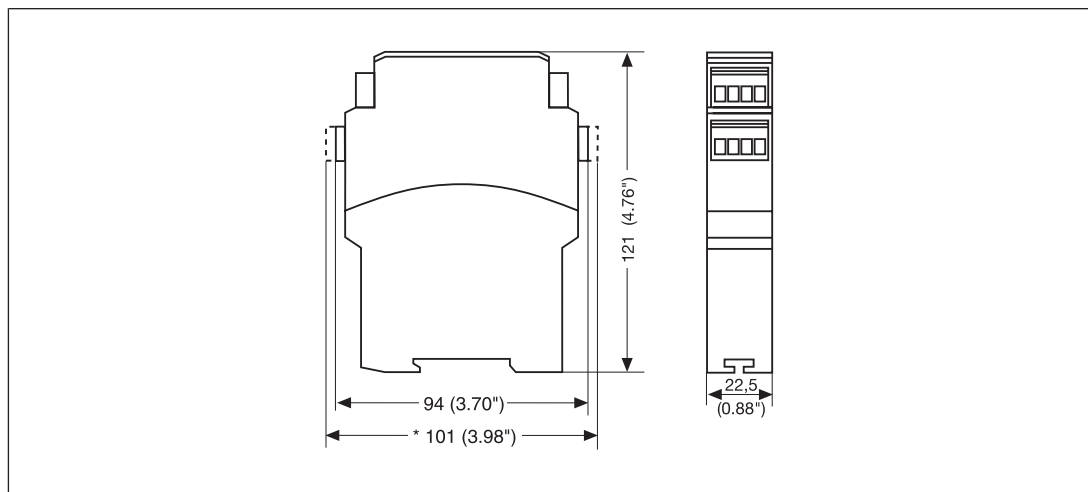

Safety relays PNOZ X PNOZ X2.3P

Technical details

| General | 777304 | 787304 |
|--|--|--|
| Approvals | CCC, CE, EAC (Eurasian), TÜV, cULus Listed | CCC, CE, EAC (Eurasian), TÜV, cULus Listed |
| Electrical data | 777304 | 787304 |
| Supply voltage | | |
| Voltage | 24 V | 24 V |
| Kind | AC/DC | AC/DC |
| Voltage tolerance | -15 %/+10 % | -15 %/+10 % |
| Output of external power supply (AC) | 4 VA | 4 VA |
| Output of external power supply (DC) | 2 W | 2 W |
| Frequency range AC | 50 - 60 Hz | 50 - 60 Hz |
| Residual ripple DC | 160 % | 160 % |
| Duty cycle | 100 % | 100 % |
| Max. inrush current impulse | | |
| Current pulse, A1 | 1,7 A | 1,7 A |
| Pulse duration, A1 | 1,5 ms | 1,5 ms |
| Inputs | 777304 | 787304 |
| Number | 2 | 2 |
| Voltage at | | |
| Input circuit DC | 24 V | 24 V |
| Start circuit DC | 24 V | 24 V |
| Feedback loop DC | 24 V | 24 V |
| Current at | | |
| Input circuit DC | 25 mA | 25 mA |
| Start circuit DC | 25 mA | 25 mA |
| Feedback loop DC | 25 mA | 25 mA |
| Min. input resistance at power-on | 21 Ohm | 21 Ohm |
| Max. overall cable resistance RI-max | | |
| Single-channel at UB DC | 30 Ohm | 30 Ohm |
| Single-channel at UB AC | 30 Ohm | 30 Ohm |
| Dual-channel with detection of shorts across contacts at UB DC | 20 Ohm | 20 Ohm |
| Dual-channel with detection of shorts across contacts at UB AC | 40 Ohm | 40 Ohm |
| Relay outputs | 777304 | 787304 |
| Number of output contacts | | |
| Safety contacts (N/O), instantaneous | 3 | 3 |

Safety relays PNOZ X PNOZ X2.3P

| Relay outputs | 777304 | 787304 |
|---|--------------------------------|--------------------------------|
| Max. short circuit current IK | 1 kA | 1 kA |
| Utilisation category | | |
| In accordance with the standard | EN 60947-4-1 | EN 60947-4-1 |
| Utilisation category of safety contacts | | |
| AC1 at | 240 V | 240 V |
| Min. current | 0,01 A | 0,01 A |
| Max. current | 6 A | 6 A |
| Max. power | 1500 VA | 1500 VA |
| DC1 at | 24 V | 24 V |
| Min. current | 0,01 A | 0,01 A |
| Max. current | 6 A | 6 A |
| Max. power | 150 W | 150 W |
| Utilisation category | | |
| In accordance with the standard | EN 60947-5-1 | EN 60947-5-1 |
| Utilisation category of safety contacts | | |
| AC15 at | 230 V | 230 V |
| Max. current | 5 A | 5 A |
| DC13 (6 cycles/min) at | 24 V | 24 V |
| Max. current | 4 A | 4 A |
| Utilisation category in accordance with UL | | |
| Voltage | 240 V AC G. P. | 240 V AC G. P. |
| With current | 6 A | 6 A |
| Voltage | 24 V DC Resistive | 24 V DC Resistive |
| With current | 6 A | 6 A |
| Pilot Duty | B300, R300 | B300, R300 |
| External contact fuse protection, safety contacts | | |
| In accordance with the standard | EN 60947-5-1 | EN 60947-5-1 |
| Max. melting integral | 100 A ² s | 100 A ² s |
| Blow-out fuse, quick | 6 A | 6 A |
| Blow-out fuse, slow | 4 A | 4 A |
| Blow-out fuse, gG | 6 A | 6 A |
| Circuit breaker 24V AC/DC, characteristic B/C | 4 A | 4 A |
| Contact material | AgSnO ₂ + 0,2 µm Au | AgSnO ₂ + 0,2 µm Au |

Safety relays PNOZ X PNOZ X2.3P

| Conventional thermal current while loading several contacts | 777304 | 787304 |
|--|---------------|---------------|
| I _{th} per contact at UB AC; AC1: 240 V, DC1: 24 V | | |
| Conv. therm. current with 1 contact | 6 A | 6 A |
| Conv. therm. current with 2 contacts | 6 A | 6 A |
| Conv. therm. current with 3 contacts | 5 A | 5 A |
| I _{th} per contact at UB DC; AC1: 240 V, DC1: 24 V | | |
| Conv. therm. current with 1 contact | 6 A | 6 A |
| Conv. therm. current with 2 contacts | 6 A | 6 A |
| Conv. therm. current with 3 contacts | 5 A | 5 A |
| Times | 777304 | 787304 |
| Switch-on delay | | |
| With automatic start typ. | 50 ms | 50 ms |
| With automatic start max. | 90 ms | 90 ms |
| With automatic start after power on typ. | 60 ms | 60 ms |
| With automatic start after power on max. | 100 ms | 100 ms |
| With manual start typ. | 40 ms | 40 ms |
| With manual start max. | 90 ms | 90 ms |
| With monitored start typ. | 40 ms | 40 ms |
| With monitored start max. | 70 ms | 70 ms |
| Delay-on de-energisation | | |
| With E-STOP typ. | 12 ms | 12 ms |
| With E-STOP max. | 30 ms | 30 ms |
| With power failure typ. | 60 ms | 60 ms |
| With power failure max. | 100 ms | 100 ms |
| Recovery time at max. switching frequency 1/s | | |
| After E-STOP | 50 ms | 50 ms |
| After power failure | 150 ms | 150 ms |
| Waiting period with a monitored start | 210 ms | 210 ms |
| Min. start pulse duration with a monitored start | 40 ms | 40 ms |
| Supply interruption before de-energisation | 20 ms | 20 ms |

Safety relays PNOZ X PNOZ X2.3P

| Times | 777304 | 787304 |
|--------------------------------------|---|---|
| Simultaneity, channel 1 and 2 max. | ∞ | ∞ |
| Environmental data | 777304 | 787304 |
| Climatic suitability | EN 60068-2-78 | EN 60068-2-78 |
| Ambient temperature | | |
| Temperature range | -10 - 55 °C | -10 - 55 °C |
| Storage temperature | | |
| Temperature range | -40 - 85 °C | -40 - 85 °C |
| Climatic suitability | | |
| Humidity | 93 % r. h. at 40 °C | 93 % r. h. at 40 °C |
| Condensation during operation | Not permitted | Not permitted |
| EMC | EN 60947-5-1, EN 61000-6-2, EN 61326-3-1 | EN 60947-5-1, EN 61000-6-2, EN 61326-3-1 |
| Vibration | | |
| In accordance with the standard | EN 60068-2-6 | EN 60068-2-6 |
| Frequency | 10 - 55 Hz | 10 - 55 Hz |
| Amplitude | 0,35 mm | 0,35 mm |
| Airgap creepage | | |
| In accordance with the standard | EN 60947-1 | EN 60947-1 |
| Overvoltage category | III / II | III / II |
| Pollution degree | 2 | 2 |
| Rated insulation voltage | 250 V | 250 V |
| Rated impulse withstand voltage | 4 kV | 4 kV |
| Protection type | | |
| Mounting area (e.g. control cabinet) | IP54 | IP54 |
| Housing | IP40 | IP40 |
| Terminals | IP20 | IP20 |
| Mechanical data | 777304 | 787304 |
| Mounting position | Any | Any |
| Mechanical life | 10,000,000 cycles | 10,000,000 cycles |
| Material | | |
| Bottom | PPO UL 94 V0 | PPO UL 94 V0 |
| Front | ABS UL 94 V0 | ABS UL 94 V0 |
| Top | PPO UL 94 V0 | PPO UL 94 V0 |
| Connection type | Screw terminal | Spring-loaded terminal |
| Mounting type | plug-in | plug-in |

Safety relays PNOZ X PNOZ X2.3P

| Mechanical data | 777304 | 787304 |
|---|--|---|
| Conductor cross section with screw terminals | | |
| 1 core flexible | 0,25 - 2,5 mm ² , 24 - 12 AWG | – |
| 2 core with the same cross section, flexible with crimp connectors, no plastic sleeve | 0,25 - 1 mm ² , 24 - 16 AWG | – |
| 2 core with the same cross section, flexible without crimp connectors or with TWIN crimp connectors | 0,2 - 1,5 mm ² , 24 - 16 AWG | – |
| Torque setting with screw terminals | 0,5 Nm | – |
| Conductor cross section with spring-loaded terminals: Flexible with/without crimp connector | – | 0,2 - 1,5 mm ² , 24 - 16 AWG |
| Spring-loaded terminals: Terminal points per connection | – | 2 |
| Stripping length with spring-loaded terminals | – | 8 mm |
| Dimensions | | |
| Height | 94 mm | 101 mm |
| Width | 22,5 mm | 22,5 mm |
| Depth | 121 mm | 121 mm |
| Weight | 205 g | 205 g |

Where standards are undated, the 2014-07 latest editions shall apply.

Safety characteristic data

| Operating Mode | EN ISO 13849-1: 2015 | EN ISO 13849-1: 2015 | EN 62061 SIL CL | EN 62061 PFH _D [1/h] | IEC 61511 SIL | IEC 61511 PFD | EN ISO 13849-1: 2015 T _M [year] |
|----------------|----------------------|----------------------|-----------------|---------------------------------|---------------|---------------|--|
| – | PL e | Cat. 4 | SIL CL 3 | 2,31E-09 | SIL 3 | 2,03E-06 | 20 |

All the units used within a safety function must be considered when calculating the safety characteristic data.

Supplementary data

The PFH value depends on the switching frequency and the load on the relay output. If the service life graphs are not accessible, the stated PFH value can be used irrespective of the switching frequency and the load, as the PFH value already considers the relay's B10d value as well as the failure rates of the other components.

Safety relays PNOZ X PNOZ X2.3P

Service life graph

The service life graphs indicate the number of cycles from which failures due to wear must be expected. The wear is mainly caused by the electrical load; the mechanical load is negligible.

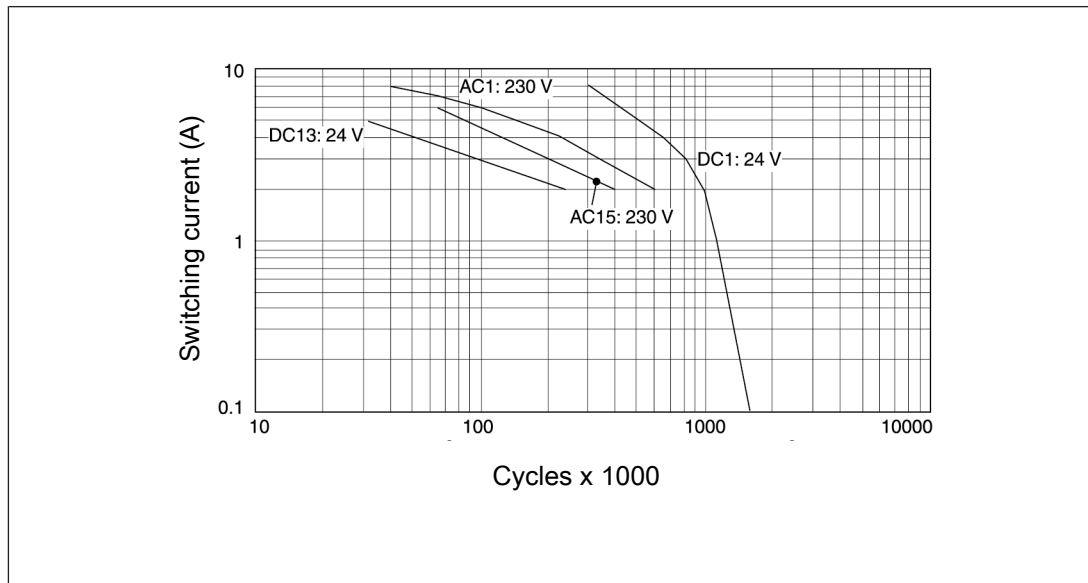

Example

- ▶ Inductive load: 2 A
- ▶ Utilisation category AC15
- ▶ Contact service life: 400 000 cycles

Provided the application to be implemented requires fewer than 400 000 cycles, the PFH value (see Technical details) can be used in the calculation.

To increase the service life, sufficient spark suppression must be provided on all output contacts. With capacitive loads, any power surges that occur must be noted. With DC contactors, use flywheel diodes for spark suppression.

Order reference

| Product type | Features | Connection type | Order no. |
|--------------|-----------|-------------------------|-----------|
| PNOZ X2.3P C | 24 VAC/DC | Spring-loaded terminals | 787 304 |
| PNOZ X2.3P | 24 VAC/DC | Screw terminals | 777 304 |

Safety relays PNOZ X PNOZ X2.7P



Unit features

- ▶ Positive-guided relay outputs:
 - 3 safety contacts (N/O), instantaneous
 - 1 auxiliary contact (N/C), instantaneous
- ▶ Connection options for:
 - E-STOP pushbuttons
 - Safety gate limit switches
 - Start button
 - Light guards and safety switches
- ▶ LED display for:
 - Supply voltage
 - Switch status of the safety contacts
- ▶ Plug-in connection terminals (either spring-loaded terminal or screw terminal)
- ▶ See order reference for unit types

Safety relays PNOZ X PNOZ X2.7P

Block diagram/terminal configuration

Type: 24 VAC/DC

▶ U_B : 24 VAC/DC; Order no. 777305, 787305

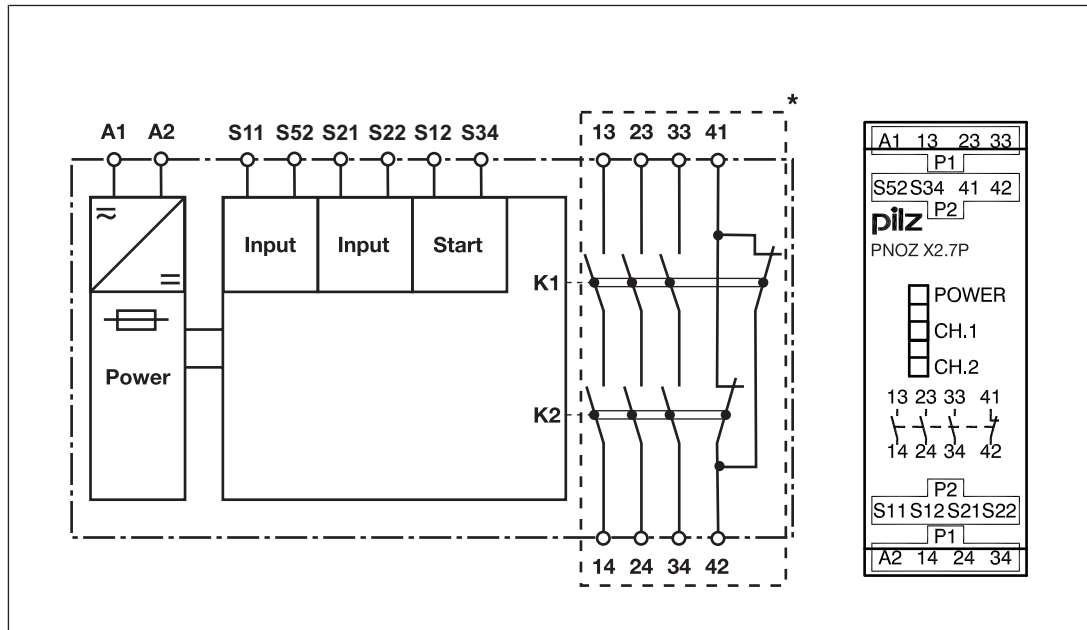

*Insulation between the non-marked area and the relay contacts: Basic insulation (over-voltage category III), Protective separation (overvoltage category II)

Safety relays PNOZ X PNOZ X2.7P

Type: 24 - 240 V AC/DC

- ▶ U_B : 24 – 240 VAC/DC; Order no. 777306, 787306

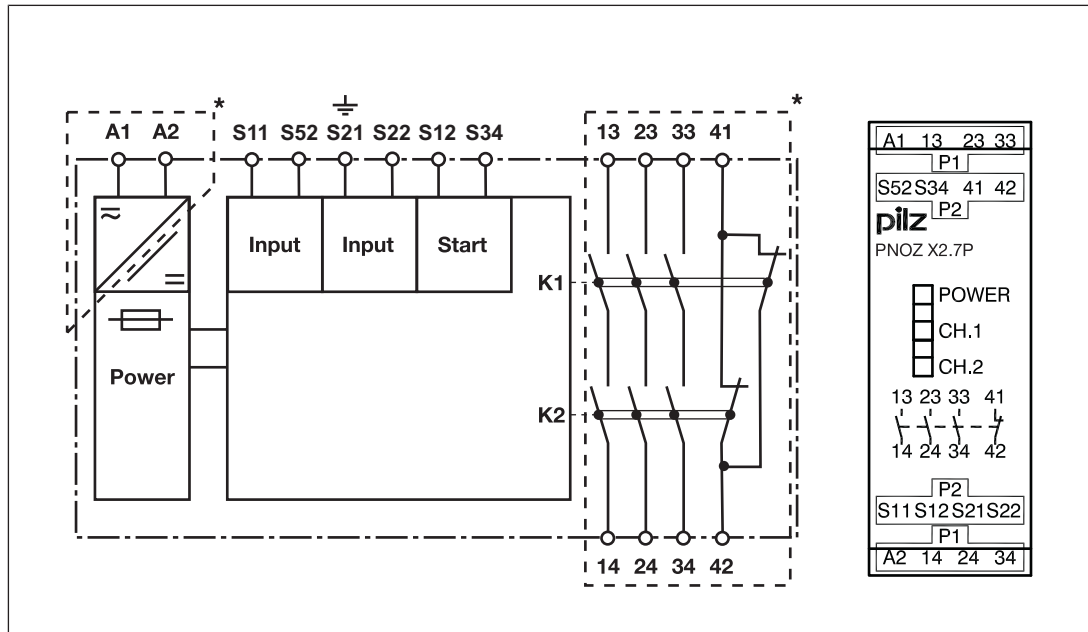

*Insulation between the non-marked area and the relay contacts: Basic insulation (over-voltage category III), Protective separation (overvoltage category II)

Function Description

The safety relay PNOZ X2.7P provides a safety-oriented interruption of a safety circuit. When supply voltage is supplied the "POWER" LED is lit. The unit is ready for operation when the start circuit S12-S34 is closed.

- ▶ Input circuit is closed (e.g. E-STOP pushbutton not operated):
 - LEDs "CH1" and "CH2" will light.
 - Safety contacts 13-14, 23-24 and 33-34 are closed, auxiliary contact 41-42 is open. The unit is active.
- ▶ Input circuit is opened (e.g. E-STOP pushbutton operated):
 - The LEDs "CH1" and "CH2" go out.
 - Safety contacts 13-14, 23-24 and 33-34 are opened redundantly, auxiliary contact 41-42 is closed.

Safety relays PNOZ X PNOZ X2.7P

Operating modes

- ▶ Single-channel operation: No redundancy in the input circuit, earth faults in the start and input circuit are detected.
- ▶ Dual-channel operation without detection of shorts across contacts: Redundant input circuit, detects PNOZ X2.7P
 - earth faults in the start and input circuit,
 - short circuits in the input circuit.
- ▶ Dual-channel operation with detection of shorts across contacts: Redundant input circuit, PNOZ X2.7P detects
 - earth faults in the start and input circuit,
 - short circuits in the input circuit,
 - shorts across contacts in the input circuit.
- ▶ Monitored start: Unit is active once the input circuit is closed and once the start circuit is closed after the waiting period has elapsed (see [Technical details \[73\]](#)).
- ▶ Increase in the number of available contacts by connecting contact expander modules or external contactors/relays.

Timing diagram

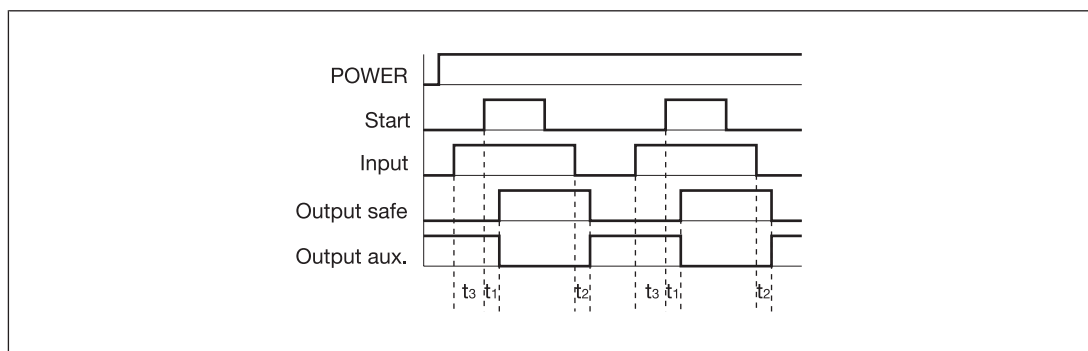

Legend

- ▶ Power: Supply voltage
- ▶ Start: Start circuit
- ▶ Input: Input circuit
- ▶ Output safe: Safety contacts
- ▶ Output aux: Auxiliary contact
- ▶ t_1 : Switch-on delay
- ▶ t_2 : Delay-on de-energisation
- ▶ t_3 : Waiting period

Safety relays PNOZ X PNOZ X2.7P

Installation

- ▶ The unit should be installed in a control cabinet with a protection type of at least IP54.
- ▶ Use the notch on the rear of the unit to attach it to a DIN rail.
- ▶ Ensure the unit is mounted securely on a vertical DIN rail (35 mm) by using a fixing element (e.g. retaining bracket or an end angle).

Wiring

Please note:

- ▶ Information given in the "[Technical details \[73\]](#)" must be followed.
- ▶ Outputs 13-14, 23-24, 33-34 are safety contacts; output 41-42 is an auxiliary contact (e.g. for display).
- ▶ Auxiliary contact 41-42 should **not** be used for safety circuits!
- ▶ To prevent contact welding, a fuse should be connected before the output contacts (see [Technical details \[73\]](#)).
- ▶ Calculation of the max. cable length l_{\max} in the input circuit:

$$l_{\max} = \frac{R_{l_{\max}}}{R_l / \text{km}}$$

$R_{l_{\max}}$ = max. overall cable resistance (see [Technical details \[73\]](#))

R_l / km = cable resistance/km

- ▶ Use copper wire that can withstand 60/75 °C.
- ▶ Sufficient fuse protection must be provided on all output contacts with capacitive and inductive loads.
- ▶ Do not switch low currents using contacts that have been used previously with high currents.
- ▶ When connecting magnetically operated, reed proximity switches, ensure that the max. peak inrush current (on the input circuit) does not overload the proximity switch.
- ▶ On 24 VAC/DC units:
The power supply must comply with the regulations for extra low voltages with safe electrical separation (SELV, PELV) in accordance with VDE 0100, Part 410.
- ▶ Ensure the wiring and EMC requirements of IEC 60204-1 are met.

Important for detection of shorts across contacts:

As this function for detecting shorts across contacts is not failsafe, it is tested by Pilz during the final control check. If there is a danger of exceeding the cable runs, we recommend the following test after the installation of the device:

1. Unit ready for operation (output contacts closed)
2. Short circuit the test terminals S12, S22 for detecting shorts across the inputs.
3. The unit's fuse must be triggered and the output contacts must open. Cable lengths in the scale of the maximum length can delay the fuse triggering for up to 2 minutes.

Safety relays PNOZ X PNOZ X2.7P

- Reset the fuse: remove the short circuit and switch off the supply voltage for approx. 1 minute.

Preparing for operation

| Supply voltage | AC | DC |
|---|----------------|--------------|
| $U_B = 24 \text{ VAC/DC}$; Order no. 777305, 787305 | | |
| $U_B = 24 - 240 \text{ VAC/DC}$; Order no. 777306, 787306 | | |
| Input circuit | Single-channel | Dual-channel |
| E-STOP without detection of shorts across contacts | | |
| E-STOP with detection of shorts across contacts | | |
| Safety gate without detection of shorts across contacts | | |
| Safety gate with detection of shorts across contacts | | |

Safety relays PNOZ X PNOZ X2.7P

| Input circuit | Single-channel | Dual-channel |
|--|-----------------|-----------------|
| Light guards or safety switch, detection of shorts across contacts via ESPE (only when $U_B = 24 \text{ VDC}$); Order no. 777305, 787305) | | |
| Start circuit | Single-channel | Dual-channel |
| Monitored start | | |
| Feedback loop | Automatic start | Monitored start |
| Contacts from external contactors | | |

Legend

- ▶ S1/S2: E-STOP/safety gate switch
- ▶ S3: Reset button
- ▶ : Switch operated
- ▶ : Gate open
- ▶ : Gate closed

Safety relays PNOZ X PNOZ X2.7P

Dimensions in mm

* with spring-loaded terminals

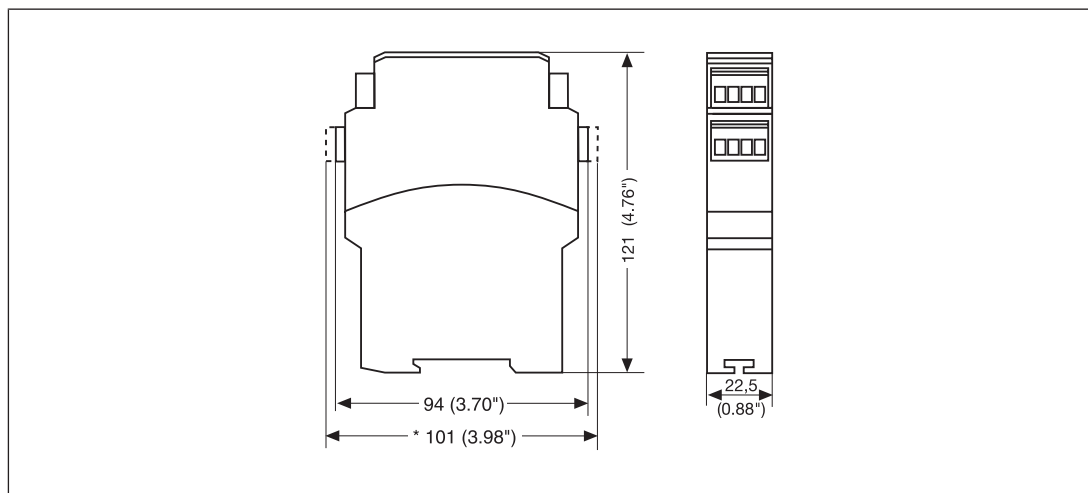

Technical details

Order no. 777305 – 777306

See below for more order numbers

| General | 777305 | 777306 |
|--------------------------------------|--|--|
| Approvals | CCC, CE, EAC (Eurasian), TÜV, cULus Listed | CCC, CE, EAC (Eurasian), TÜV, cULus Listed |
| Electrical data | 777305 | 777306 |
| Supply voltage | | |
| Voltage | 24 V | 24 - 240 V |
| Kind | AC/DC | AC/DC |
| Voltage tolerance | -15 %/+10 % | -15 %/+10 % |
| Output of external power supply (AC) | 5,5 VA | 4,5 VA |
| Output of external power supply (DC) | 2,5 W | 2 W |
| Frequency range AC | 50 - 60 Hz | 50 - 60 Hz |
| Residual ripple DC | 160 % | 160 % |
| Duty cycle | 100 % | 100 % |
| Max. inrush current impulse | | |
| Current pulse, A1 | 1,7 A | – |
| Pulse duration, A1 | 3,3 ms | – |
| Inputs | 777305 | 777306 |
| Number | 2 | 2 |

Safety relays PNOZ X PNOZ X2.7P

| Inputs | 777305 | 777306 |
|---|---------------------|---------------------|
| Voltage at | | |
| Input circuit DC | 24 V | 24 V |
| Start circuit DC | 24 V | 24 V |
| Feedback loop DC | 24 V | 24 V |
| Current at | | |
| Input circuit DC | 30 mA | 25 mA |
| Start circuit DC | 40 mA | 50 mA |
| Feedback loop DC | 40 mA | 50 mA |
| Min. input resistance at power-on | 71 Ohm | 141 Ohm |
| Max. overall cable resistance RI-max | | |
| Single-channel at UB DC | 30 Ohm | 45 Ohm |
| Single-channel at UB AC | 100 Ohm | 45 Ohm |
| Dual-channel without detection of shorts across contacts at UB DC | 50 Ohm | 80 Ohm |
| Dual-channel without detection of shorts across contacts at UB AC | 100 Ohm | 80 Ohm |
| Dual-channel with detection of shorts across contacts at UB DC | 15 Ohm | 15 Ohm |
| Dual-channel with detection of shorts across contacts at UB AC | 15 Ohm | 15 Ohm |
| Relay outputs | 777305 | 777306 |
| Number of output contacts | | |
| Safety contacts (N/O), instantaneous | 3 | 3 |
| Auxiliary contacts (N/C) | 1 | 1 |
| Max. short circuit current IK | 1 kA | 1 kA |
| Utilisation category | | |
| In accordance with the standard | EN 60947-4-1 | EN 60947-4-1 |
| Utilisation category of safety contacts | | |
| AC1 at | 240 V | 240 V |
| Min. current | 0,01 A | 0,01 A |
| Max. current | 6 A | 6 A |
| Max. power | 1500 VA | 1500 VA |
| DC1 at | 24 V | 24 V |
| Min. current | 0,01 A | 0,01 A |
| Max. current | 6 A | 6 A |
| Max. power | 150 W | 150 W |

Safety relays PNOZ X PNOZ X2.7P

| Relay outputs | 777305 | 777306 |
|---|-------------------------------|-------------------------------|
| Utilisation category of auxiliary contacts | | |
| AC1 at | 240 V | 240 V |
| Min. current | 0,01 A | 0,01 A |
| Max. current | 6 A | 6 A |
| Max. power | 1500 VA | 1500 VA |
| DC1 at | 24 V | 24 V |
| Min. current | 0,01 A | 0,01 A |
| Max. current | 6 A | 6 A |
| Max. power | 150 W | 150 W |
| Utilisation category | | |
| In accordance with the standard | EN 60947-5-1 | EN 60947-5-1 |
| Utilisation category of safety contacts | | |
| AC15 at | 230 V | 230 V |
| Max. current | 5 A | 3 A |
| DC13 (6 cycles/min) at | 24 V | 24 V |
| Max. current | 5 A | 4 A |
| Utilisation category of auxiliary contacts | | |
| AC15 at | 230 V | 230 V |
| Max. current | 5 A | 3 A |
| DC13 (6 cycles/min) at | 24 V | 24 V |
| Max. current | 5 A | 4 A |
| Utilisation category in accordance with UL | | |
| Voltage | 240 V AC G.U. (same polarity) | 250 V AC G.U. (same polarity) |
| With current | 6 A | 6 A |
| Voltage | 24 V DC G. P. | 24 V DC G. P. |
| With current | 6 A | 6 A |
| Pilot Duty | R300 | B300, R300 |
| External contact fuse protection, safety contacts | | |
| In accordance with the standard | EN 60947-5-1 | EN 60947-5-1 |
| Max. melting integral | 260 A ² s | 66 A ² s |
| Blow-out fuse, quick | 10 A | 6 A |
| Blow-out fuse, slow | 6 A | 4 A |
| Blow-out fuse, gG | 6 A | 6 A |
| Circuit breaker 24V AC/DC, characteristic B/C | 6 A | 4 A |

Safety relays PNOZ X PNOZ X2.7P

| Relay outputs | 777305 | 777306 |
|---|----------------------|---------------------|
| External contact fuse protection, auxiliary contacts | | |
| Max. melting integral | 160 A ² s | 66 A ² s |
| Blow-out fuse, quick | 10 A | 6 A |
| Blow-out fuse, slow | 6 A | 4 A |
| Blow-out fuse, gG | 6 A | 6 A |
| Circuit breaker 24 V AC/DC, characteristic B/C | 6 A | 4 A |
| Contact material | AgCuNi + 0,2 µm Au | AgCuNi + 0,2 µm Au |
| Conventional thermal current while loading several contacts | 777305 | 777306 |
| Ith per contact at UB AC; AC1: 240 V, DC1: 24 V | | |
| Conv. therm. current with 1 contact | 6 A | 6 A |
| Conv. therm. current with 2 contacts | 4 A | 6 A |
| Conv. therm. current with 3 contacts | 3,5 A | 4,5 A |
| Ith per contact at UB DC; AC1: 240 V, DC1: 24 V | | |
| Conv. therm. current with 1 contact | 6 A | 6 A |
| Conv. therm. current with 2 contacts | 6 A | 6 A |
| Conv. therm. current with 3 contacts | 5 A | 4,5 A |
| Times | 777305 | 777306 |
| Switch-on delay | | |
| With monitored start typ. | 30 ms | 30 ms |
| With monitored start max. | 50 ms | 40 ms |
| Delay-on de-energisation | | |
| With E-STOP typ. | 15 ms | 10 ms |
| With E-STOP max. | 30 ms | 20 ms |
| With power failure typ. | 60 ms | – |
| With power failure max. | 100 ms | – |
| With power failure typ. UB 240 V – | | 1100 ms |
| With power failure max. UB 240 V | – | 1500 ms |
| With power failure typ. UB 24 V – | | 180 ms |
| With power failure max. UB 24 V – | | 230 ms |

Safety relays PNOZ X PNOZ X2.7P

| Times | 777305 | 777306 |
|--|--|--|
| Recovery time at max. switching frequency 1/s | | |
| After E-STOP | 50 ms | 50 ms |
| After power failure | 200 ms | 1500 ms |
| Waiting period with a monitored start | 250 ms | 300 ms |
| Min. start pulse duration with a monitored start | 30 ms | 30 ms |
| Supply interruption before de-energisation | 20 ms | 20 ms |
| Simultaneity, channel 1 and 2 max. | ∞ | ∞ |
| Environmental data | 777305 | 777306 |
| Climatic suitability | EN 60068-2-78 | EN 60068-2-78 |
| Ambient temperature | | |
| Temperature range | -35 - 55 °C | -10 - 55 °C |
| Storage temperature | | |
| Temperature range | -40 - 85 °C | -40 - 85 °C |
| Climatic suitability | | |
| Humidity | 93 % r. h. at 40 °C | 93 % r. h. at 40 °C |
| Condensation during operation | Not permitted | Not permitted |
| EMC | EN 60947-5-1, EN 61000-6-2, EN 61000-6-4, EN 61326-3-1 | EN 60947-5-1, EN 61000-6-2, EN 61000-6-4, EN 61326-3-1 |
| Vibration | | |
| In accordance with the standard | EN 60068-2-6 | EN 60068-2-6 |
| Frequency | 10 - 55 Hz | 10 - 55 Hz |
| Amplitude | 0,35 mm | 0,35 mm |
| Airgap creepage | | |
| In accordance with the standard | EN 60947-1 | EN 60947-1 |
| Overvoltage category | III / II | III / II |
| Pollution degree | 2 | 2 |
| Rated insulation voltage | 250 V | 250 V |
| Rated impulse withstand voltage | 4 kV | 4 kV |
| Protection type | | |
| Mounting area (e.g. control cabinet) | IP54 | IP54 |
| Housing | IP40 | IP40 |
| Terminals | IP20 | IP20 |
| Mechanical data | 777305 | 777306 |
| Mounting position | Any | Any |
| Mechanical life | 10,000,000 cycles | 10,000,000 cycles |

Safety relays PNOZ X PNOZ X2.7P

| Mechanical data | 777305 | 777306 |
|---|---|---|
| Material | | |
| Bottom | PPO UL 94 V0 | PPO UL 94 V0 |
| Front | ABS UL 94 V0 | ABS UL 94 V0 |
| Top | PPO UL 94 V0 | PPO UL 94 V0 |
| Connection type | Screw terminal | Screw terminal |
| Mounting type | plug-in | plug-in |
| Conductor cross section with screw terminals | | |
| 1 core flexible | 0,25 - 2,5 mm², 24 - 12 AWG | 0,25 - 2,5 mm², 24 - 12 AWG |
| 2 core with the same cross section, flexible with crimp connectors, no plastic sleeve | 0,25 - 1 mm², 24 - 16 AWG | 0,25 - 1 mm², 24 - 16 AWG |
| 2 core with the same cross section, flexible without crimp connectors or with TWIN crimp connectors | 0,2 - 1,5 mm², 24 - 16 AWG | 0,2 - 1,5 mm², 24 - 16 AWG |
| Torque setting with screw terminals | 0,5 Nm | 0,5 Nm |
| Dimensions | | |
| Height | 94 mm | 94 mm |
| Width | 22,5 mm | 22,5 mm |
| Depth | 121 mm | 121 mm |
| Weight | 190 g | 210 g |

Where standards are undated, the 2014-07 latest editions shall apply.

Order no. 787305 – 787306

| General | 787305 | 787306 |
|--------------------------------------|---|---|
| Approvals | CCC, CE, EAC (Eurasian), TÜV, cULus Listed | CCC, CE, EAC (Eurasian), TÜV, cULus Listed |
| Electrical data | 787305 | 787306 |
| Supply voltage | | |
| Voltage | 24 V | 24 - 240 V |
| Kind | AC/DC | AC/DC |
| Voltage tolerance | -15 %/+10 % | -15 %/+10 % |
| Output of external power supply (AC) | 5,5 VA | 4,5 VA |
| Output of external power supply (DC) | 2,5 W | 2 W |
| Frequency range AC | 50 - 60 Hz | 50 - 60 Hz |
| Residual ripple DC | 160 % | 160 % |
| Duty cycle | 100 % | 100 % |

Safety relays PNOZ X PNOZ X2.7P

| Electrical data | 787305 | 787306 |
|---|---------------------|---------------------|
| Max. inrush current impulse | | |
| Current pulse, A1 | 1,7 A | – |
| Pulse duration, A1 | 3,3 ms | – |
| Inputs | 787305 | 787306 |
| Number | 2 | 2 |
| Voltage at | | |
| Input circuit DC | 24 V | 24 V |
| Start circuit DC | 24 V | 24 V |
| Feedback loop DC | 24 V | 24 V |
| Current at | | |
| Input circuit DC | 30 mA | 25 mA |
| Start circuit DC | 40 mA | 50 mA |
| Feedback loop DC | 40 mA | 50 mA |
| Min. input resistance at power-on | 71 Ohm | 141 Ohm |
| Max. overall cable resistance R _I -max | | |
| Single-channel at UB DC | 30 Ohm | 45 Ohm |
| Single-channel at UB AC | 100 Ohm | 45 Ohm |
| Dual-channel without detection of shorts across contacts at UB DC | 50 Ohm | 80 Ohm |
| Dual-channel without detection of shorts across contacts at UB AC | 100 Ohm | 80 Ohm |
| Dual-channel with detection of shorts across contacts at UB DC | 15 Ohm | 15 Ohm |
| Dual-channel with detection of shorts across contacts at UB AC | 15 Ohm | 15 Ohm |
| Relay outputs | 787305 | 787306 |
| Number of output contacts | | |
| Safety contacts (N/O), instantaneous | 3 | 3 |
| Auxiliary contacts (N/C) | 1 | 1 |
| Max. short circuit current I _K | 1 kA | 1 kA |
| Utilisation category | | |
| In accordance with the standard | EN 60947-4-1 | EN 60947-4-1 |

Safety relays PNOZ X PNOZ X2.7P

| Relay outputs | 787305 | 787306 |
|--|-------------------------------|-------------------------------|
| Utilisation category of safety contacts | | |
| AC1 at | 240 V | 240 V |
| Min. current | 0,01 A | 0,01 A |
| Max. current | 6 A | 6 A |
| Max. power | 1500 VA | 1500 VA |
| DC1 at | 24 V | 24 V |
| Min. current | 0,01 A | 0,01 A |
| Max. current | 6 A | 6 A |
| Max. power | 150 W | 150 W |
| Utilisation category of auxiliary contacts | | |
| AC1 at | 240 V | 240 V |
| Min. current | 0,01 A | 0,01 A |
| Max. current | 6 A | 6 A |
| Max. power | 1500 VA | 1500 VA |
| DC1 at | 24 V | 24 V |
| Min. current | 0,01 A | 0,01 A |
| Max. current | 6 A | 6 A |
| Max. power | 150 W | 150 W |
| Utilisation category | | |
| In accordance with the standard | EN 60947-5-1 | EN 60947-5-1 |
| Utilisation category of safety contacts | | |
| AC15 at | 230 V | 230 V |
| Max. current | 5 A | 3 A |
| DC13 (6 cycles/min) at | 24 V | 24 V |
| Max. current | 5 A | 4 A |
| Utilisation category of auxiliary contacts | | |
| AC15 at | 230 V | 230 V |
| Max. current | 5 A | 3 A |
| DC13 (6 cycles/min) at | 24 V | 24 V |
| Max. current | 5 A | 4 A |
| Utilisation category in accordance with UL | | |
| Voltage | 240 V AC G.U. (same polarity) | 250 V AC G.U. (same polarity) |
| With current | 6 A | 6 A |
| Voltage | 24 V DC G. P. | 24 V DC G. P. |
| With current | 6 A | 6 A |
| Pilot Duty | R300 | B300, R300 |

Safety relays PNOZ X PNOZ X2.7P

| Relay outputs | 787305 | 787306 |
|--|---------------------------|---------------------------|
| External contact fuse protection, safety contacts | | |
| In accordance with the standard | EN 60947-5-1 | EN 60947-5-1 |
| Max. melting integral | 260 A²s | 66 A²s |
| Blow-out fuse, quick | 10 A | 6 A |
| Blow-out fuse, slow | 6 A | 4 A |
| Blow-out fuse, gG | 6 A | 6 A |
| Circuit breaker 24V AC/DC, characteristic B/C | 6 A | 4 A |
| External contact fuse protection, auxiliary contacts | | |
| Max. melting integral | 160 A²s | 66 A²s |
| Blow-out fuse, quick | 10 A | 6 A |
| Blow-out fuse, slow | 6 A | 4 A |
| Blow-out fuse, gG | 6 A | 6 A |
| Circuit breaker 24 V AC/DC, characteristic B/C | 6 A | 4 A |
| Contact material | AgCuNi + 0,2 µm Au | AgCuNi + 0,2 µm Au |
| Conventional thermal current while loading several contacts | 787305 | 787306 |
| I _{th} per contact at UB AC; AC1: 240 V, DC1: 24 V | | |
| Conv. therm. current with 1 contact | 6 A | 6 A |
| Conv. therm. current with 2 contacts | 4 A | 6 A |
| Conv. therm. current with 3 contacts | 3,5 A | 4,5 A |
| I _{th} per contact at UB DC; AC1: 240 V, DC1: 24 V | | |
| Conv. therm. current with 1 contact | 6 A | 6 A |
| Conv. therm. current with 2 contacts | 6 A | 6 A |
| Conv. therm. current with 3 contacts | 5 A | 4,5 A |
| Times | 787305 | 787306 |
| Switch-on delay | | |
| With monitored start typ. | 30 ms | 30 ms |
| With monitored start max. | 50 ms | 40 ms |

Safety relays PNOZ X PNOZ X2.7P

| Times | 787305 | 787306 |
|--|---|---|
| Delay-on de-energisation | | |
| With E-STOP typ. | 15 ms | 10 ms |
| With E-STOP max. | 30 ms | 20 ms |
| With power failure typ. | 60 ms | – |
| With power failure max. | 100 ms | – |
| With power failure typ. UB 240 V – | | 1100 ms |
| With power failure max. UB 240 V | – | 1500 ms |
| With power failure typ. UB 24 V – | | 180 ms |
| With power failure max. UB 24 V – | | 230 ms |
| Recovery time at max. switching frequency 1/s | | |
| After E-STOP | 50 ms | 50 ms |
| After power failure | 200 ms | 1500 ms |
| Waiting period with a monitored start | | |
| | 250 ms | 300 ms |
| Min. start pulse duration with a monitored start | | |
| | 30 ms | 30 ms |
| Supply interruption before de-energisation | | |
| | 20 ms | 20 ms |
| Simultaneity, channel 1 and 2 max. | | |
| | ∞ | ∞ |
| Environmental data | | |
| | 787305 | 787306 |
| Climatic suitability | | |
| | EN 60068-2-78 | EN 60068-2-78 |
| Ambient temperature | | |
| Temperature range | -35 - 55 °C | -10 - 55 °C |
| Storage temperature | | |
| Temperature range | -40 - 85 °C | -40 - 85 °C |
| Climatic suitability | | |
| Humidity | 93 % r. h. at 40 °C | 93 % r. h. at 40 °C |
| Condensation during operation | | |
| | Not permitted | Not permitted |
| EMC | | |
| | EN 60947-5-1, EN 61000-6-2, EN 61000-6-4, EN 61326-3-1 | EN 60947-5-1, EN 61000-6-2, EN 61000-6-4, EN 61326-3-1 |
| Vibration | | |
| In accordance with the standard | EN 60068-2-6 | EN 60068-2-6 |
| Frequency | 10 - 55 Hz | 10 - 55 Hz |
| Amplitude | 0,35 mm | 0,35 mm |
| Airgap creepage | | |
| In accordance with the standard | EN 60947-1 | EN 60947-1 |
| Overvoltage category | III / II | III / II |
| Pollution degree | 2 | 2 |
| Rated insulation voltage | | |
| | 250 V | 250 V |
| Rated impulse withstand voltage | | |
| | 4 kV | 4 kV |

Safety relays PNOZ X PNOZ X2.7P

| Environmental data | 787305 | 787306 |
|---|---|---|
| Protection type | | |
| Mounting area (e.g. control cabinet) | IP54 | IP54 |
| Housing | IP40 | IP40 |
| Terminals | IP20 | IP20 |
| Mechanical data | 787305 | 787306 |
| Mounting position | Any | Any |
| Mechanical life | 10,000,000 cycles | 10,000,000 cycles |
| Material | | |
| Bottom | PPO UL 94 V0 | PPO UL 94 V0 |
| Front | ABS UL 94 V0 | ABS UL 94 V0 |
| Top | PPO UL 94 V0 | PPO UL 94 V0 |
| Connection type | Spring-loaded terminal | Spring-loaded terminal |
| Mounting type | plug-in | plug-in |
| Conductor cross section with spring-loaded terminals: Flexible with/without crimp connector | 0,2 - 1,5 mm ² , 24 - 16 AWG | 0,2 - 1,5 mm ² , 24 - 16 AWG |
| Spring-loaded terminals: Terminal points per connection | 2 | 2 |
| Stripping length with spring-loaded terminals | 8 mm | 8 mm |
| Dimensions | | |
| Height | 101 mm | 101 mm |
| Width | 22,5 mm | 22,5 mm |
| Depth | 121 mm | 121 mm |
| Weight | 190 g | 210 g |

Where standards are undated, the 2014-07 latest editions shall apply.

Safety characteristic data

| Operating Mode | EN ISO 13849-1: 2015 | EN ISO 13849-1: 2015 | EN 62061 SIL CL | EN 62061 PFH _D [1/h] | IEC 61511 SIL | IEC 61511 PFD | EN ISO 13849-1: 2015 T _M [year] |
|----------------|----------------------|----------------------|-----------------|---------------------------------|---------------|---------------|--|
| PL | Category | | | | | | |
| – | PL e | Cat. 4 | SIL CL 3 | 2,31E-09 | SIL 3 | 2,03E-06 | 20 |

All the units used within a safety function must be considered when calculating the safety characteristic data.

Safety relays PNOZ X PNOZ X2.7P

Supplementary data

The PFH value depends on the switching frequency and the load on the relay output. If the service life graphs are not accessible, the stated PFH value can be used irrespective of the switching frequency and the load, as the PFH value already considers the relay's B10d value as well as the failure rates of the other components.

Service life graph

The service life graphs indicate the number of cycles from which failures due to wear must be expected. The wear is mainly caused by the electrical load; the mechanical load is negligible.

Unit types with UB 24 VAC/DC

- ▶ U_B : 24 VAC/DC; Order no. 777305, 787305

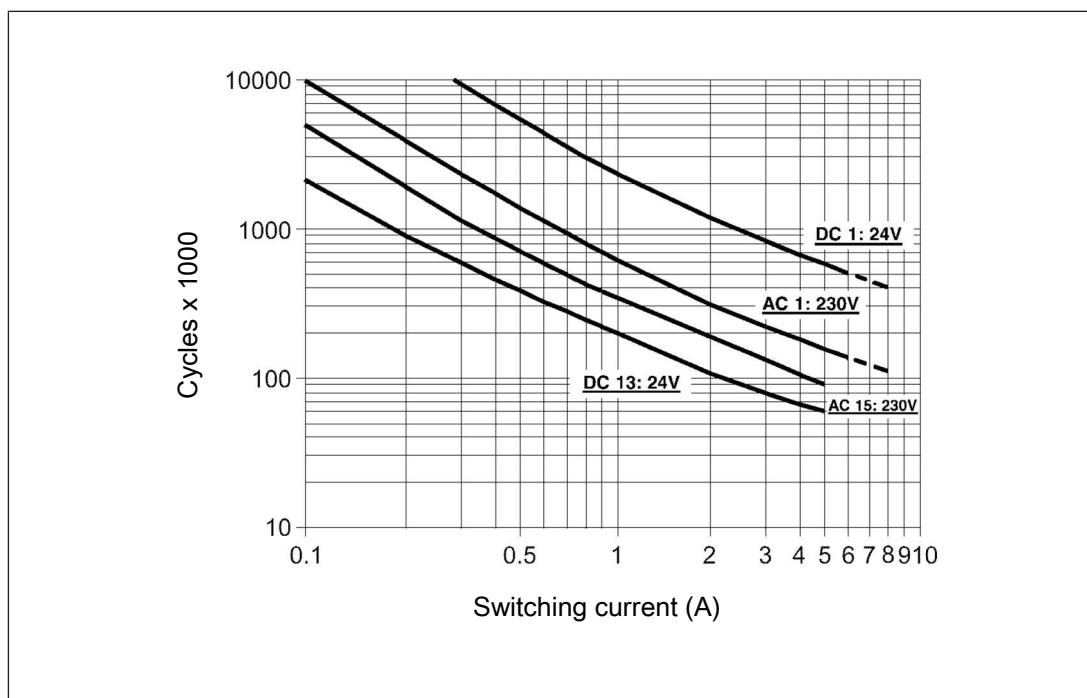

Fig.: Service life graphs at 24 V DC and 230 V AC

Safety relays PNOZ X PNOZ X2.7P

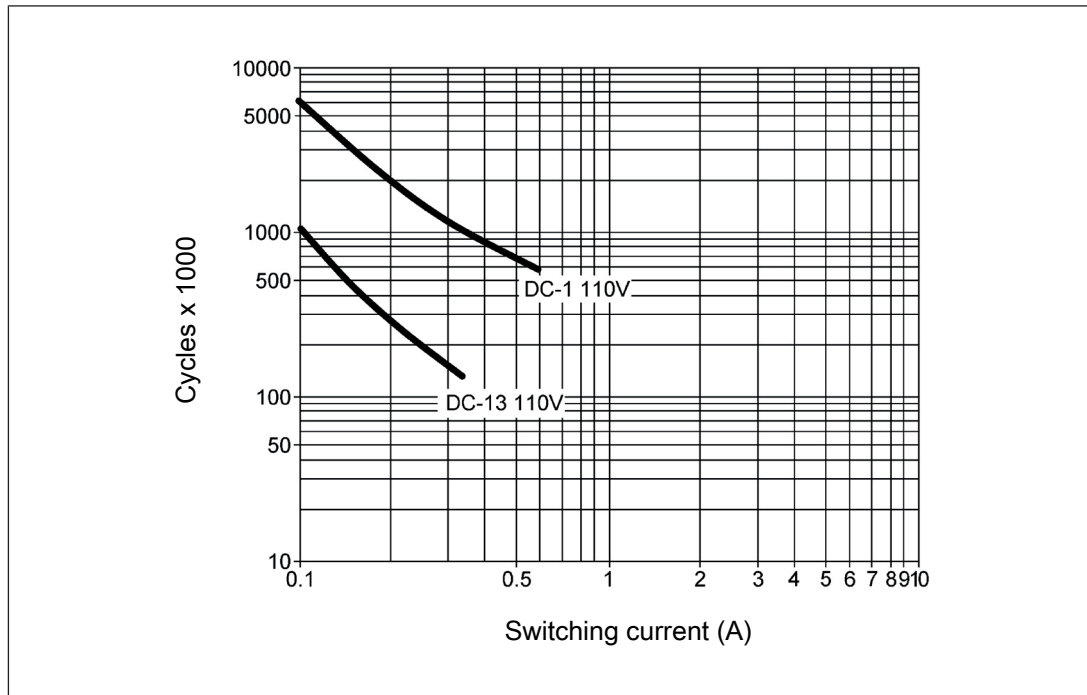

Fig.: Service life graphs at 110 V DC

Example

- ▶ Inductive load: 0.2 A
- ▶ Utilisation category: AC15
- ▶ Contact service life: 2 000 000 cycles

Provided the application to be implemented requires fewer than 2 000 000 cycles, the PFH value (see [Technical details \[73\]](#)) can be used in the calculation.

To increase the service life, sufficient spark suppression must be provided on all output contacts. With capacitive loads, any power surges that occur must be noted. With DC contactors, use flywheel diodes for spark suppression.

Safety relays PNOZ X PNOZ X2.7P

Unit types with UB 24-240 VAC/DC

▶ U_B : 24 – 240 VAC/DC; Order no. 777306, 787306

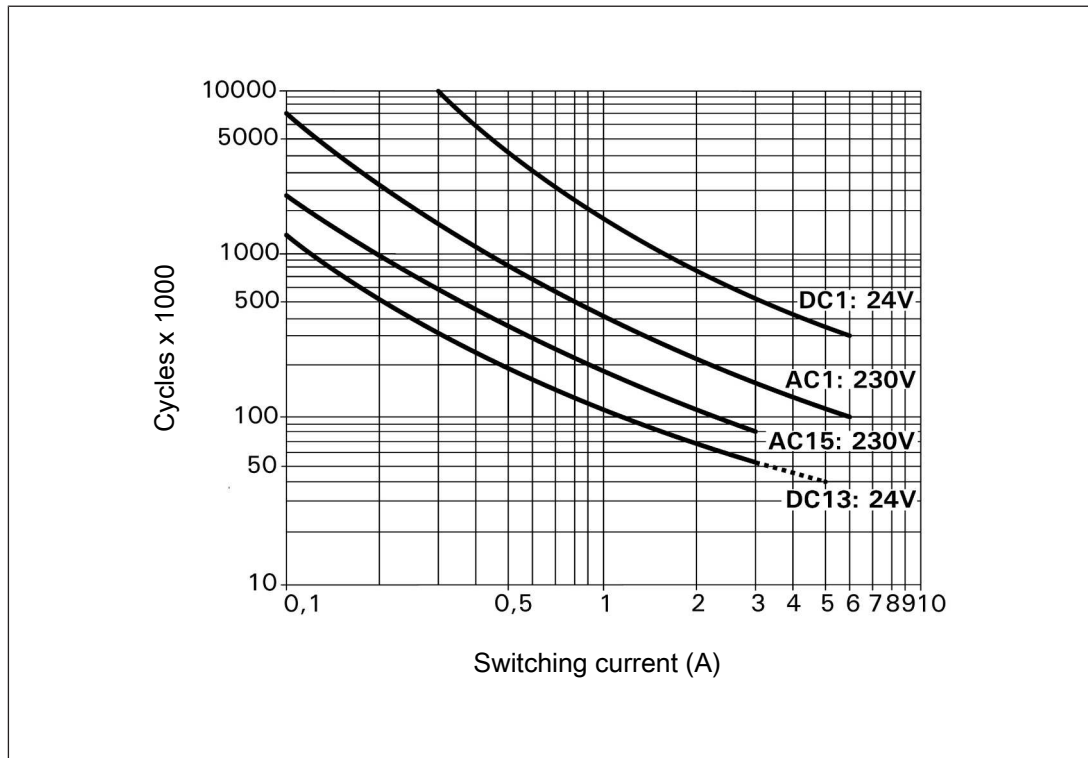

Fig.: Service life graphs at 24 V DC and 230 V AC

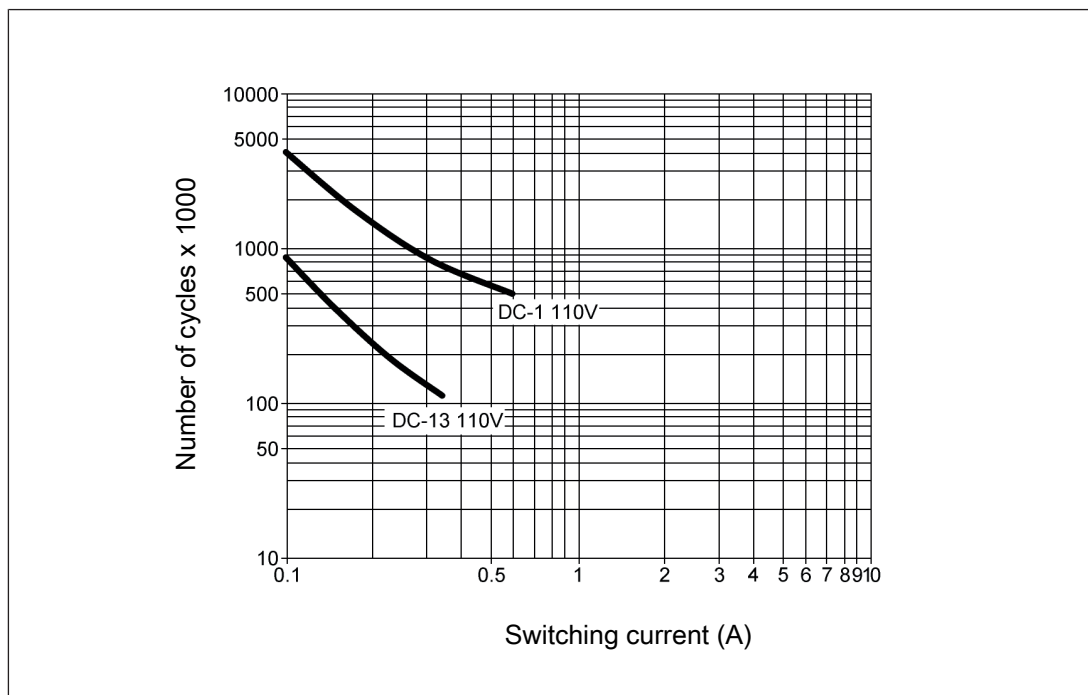

Fig.: Service life graphs at 110 V DC

Safety relays PNOZ X PNOZ X2.7P

Example

- ▶ Inductive load: 0.2 A
- ▶ Utilisation category: AC15
- ▶ Contact service life: 1 000 000 cycles

Provided the application to be implemented requires fewer than 1 000 000 cycles, the PFH value (see [Technical details \[73\]](#)) can be used in the calculation.

To increase the service life, sufficient spark suppression must be provided on all relay contacts. With capacitive loads, any power surges that occur must be noted. With DC contactors, use flywheel diodes for spark suppression.

Order reference

| Product type | Features | Connection type | Order no. |
|--------------|------------------|-------------------------|-----------|
| PNOZ X2.7P C | 24 VAC/DC | Spring-loaded terminals | 787 305 |
| PNOZ X2.7P | 24 VAC/DC | Screw terminals | 777 305 |
| PNOZ X2.7P C | 24 - 240 V AC/DC | Spring-loaded terminals | 787 306 |
| PNOZ X2.7P | 24 - 240 V AC/DC | Screw terminals | 777 306 |

Safety relays PNOZ X PNOZ X2.8P



Unit features

- ▶ Positive-guided relay outputs:
 - 3 safety contacts (N/O), instantaneous
 - 1 auxiliary contact (N/C), instantaneous
- ▶ Connection options for:
 - E-STOP pushbuttons
 - Safety gate limit switches
 - Start button
 - Light guards and safety switches
- ▶ LED display for:
 - Supply voltage
 - Switch status of the safety contacts
- ▶ Plug-in connection terminals (either spring-loaded terminal or screw terminal)
- ▶ See order reference for unit types

Safety relays PNOZ X PNOZ X2.8P

Block diagram/terminal configuration

Type: 24 VAC/DC

▶ U_B : 24 VAC/DC; Order no. 777301, 787301

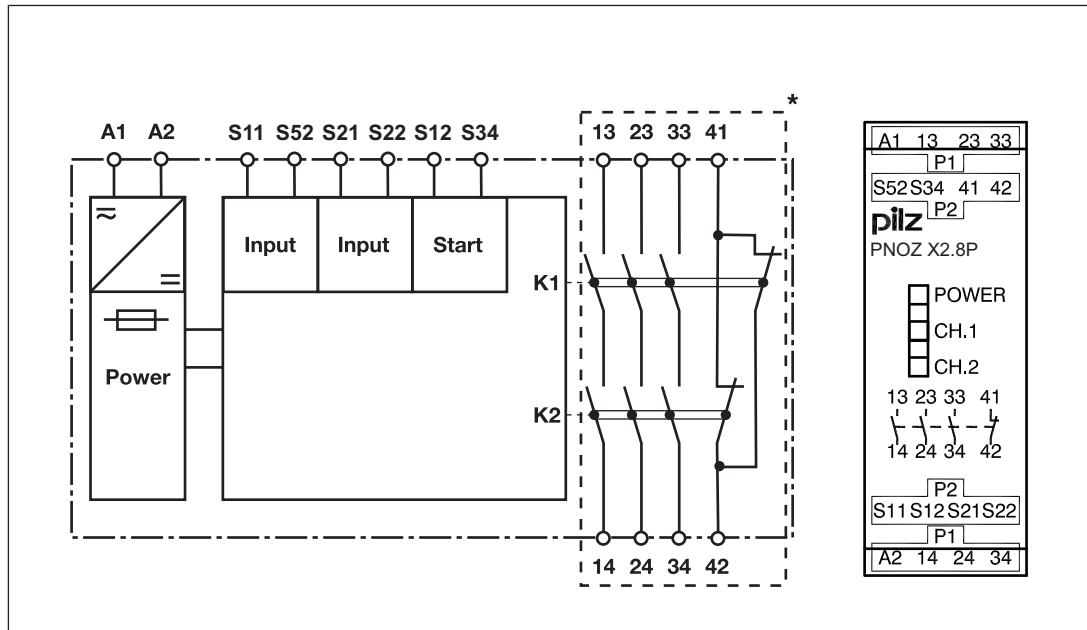

*Insulation between the non-marked area and the relay contacts: Basic insulation (over-voltage category III), Protective separation (overvoltage category II)

Safety relays PNOZ X PNOZ X2.8P

Type: 24 - 240 V AC/DC

- ▶ U_B : 24 – 240 VAC/DC; Order no. 777302, 787302

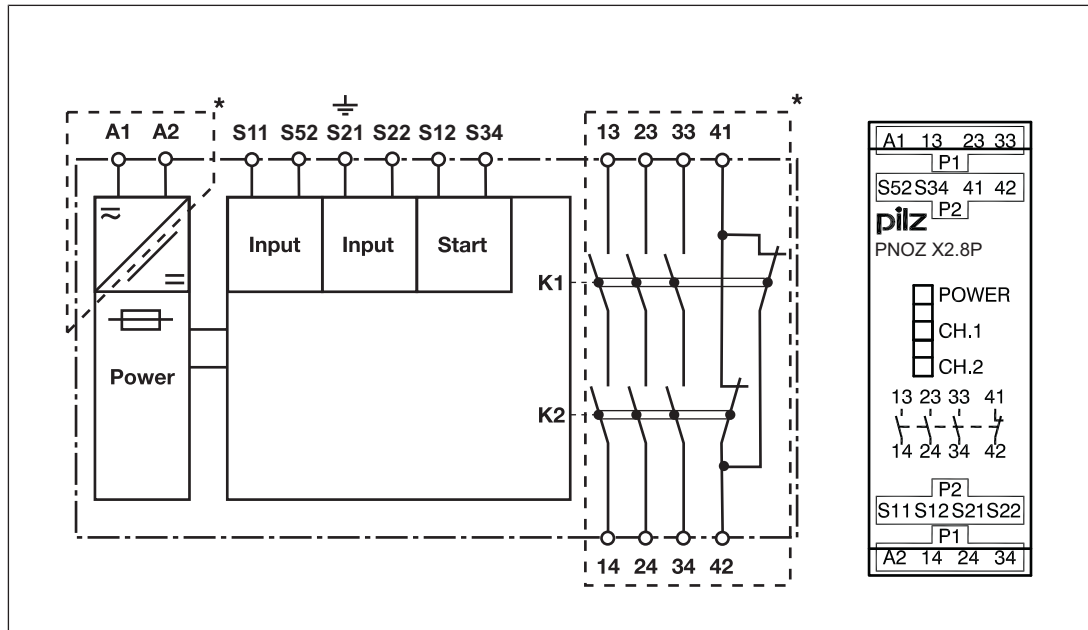

*Insulation between the non-marked area and the relay contacts: Basic insulation (over-voltage category III), Protective separation (overvoltage category II)

Function Description

The safety relay PPNOZ X2.8P provides a safety-oriented interruption of a safety circuit. When supply voltage is supplied the "POWER" LED is lit. The unit is ready for operation when the start circuit S12-S34 is closed.

- ▶ Input circuit is closed (e.g. E-STOP pushbutton not operated):
 - LEDs "CH1" and "CH2" will light.
 - Safety contacts 13-14, 23-24 and 33-34 are closed, auxiliary contact 41-42 is open. The unit is active.
- ▶ Input circuit is opened (e.g. E-STOP pushbutton operated):
 - The LEDs "CH1" and "CH2" go out.
 - Safety contacts 13-14, 23-24 and 33-34 are opened redundantly, auxiliary contact 41-42 is closed.

Safety relays PNOZ X PNOZ X2.8P

Operating modes

- ▶ Single-channel operation: No redundancy in the input circuit, earth faults in the start and input circuit are detected.
- ▶ Dual-channel operation without detection of shorts across contacts: Redundant input circuit, detects PNOZ X2.8P
 - earth faults in the start and input circuit,
 - short circuits in the input circuit.
- ▶ Dual-channel operation with detection of shorts across contacts: Redundant input circuit, PNOZ X2.8P detects
 - earth faults in the start and input circuit,
 - short circuits in the input circuit,
 - shorts across contacts in the input circuit.
- ▶ Automatic start: Unit is active once the input circuit has been closed.
- ▶ Manual start: Unit is active once the input circuit and the start circuit are closed.
- ▶ Increase in the number of available contacts by connecting contact expander modules or external contactors/relays.

Timing diagram

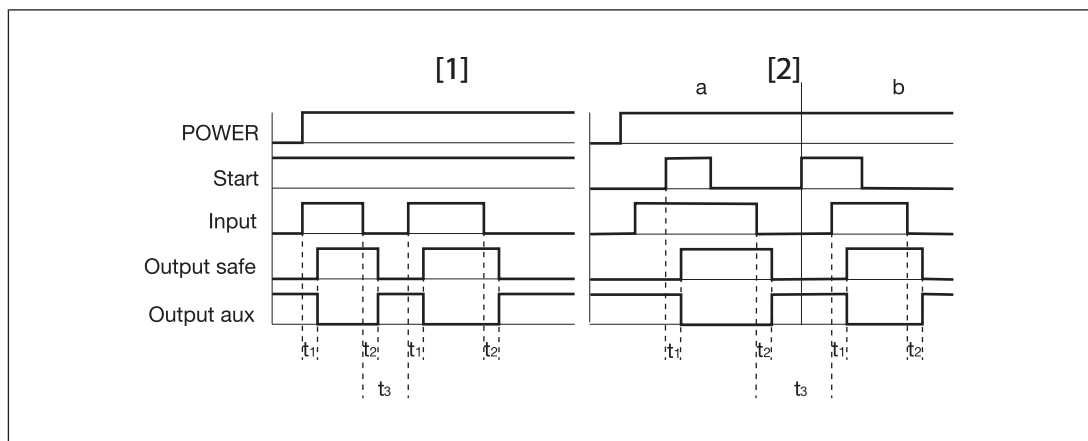

Legend

- ▶ Power: Supply voltage
- ▶ Start: Start circuit
- ▶ Input: Input circuit
- ▶ Output safe: Safety contacts
- ▶ Output aux: Auxiliary contact
- ▶ [1]: Automatic start
- ▶ [2]: Manual start
- ▶ a: Input circuit closes before start circuit

Safety relays PNOZ X PNOZ X2.8P

- ▶ b: Start circuit closes before input circuit
- ▶ t_1 : Switch-on delay
- ▶ t_2 : Delay-on de-energisation
- ▶ t_3 : Recovery time

Installation

- ▶ The unit should be installed in a control cabinet with a protection type of at least IP54.
- ▶ Use the notch on the rear of the unit to attach it to a DIN rail.
- ▶ Ensure the unit is mounted securely on a vertical DIN rail (35 mm) by using a fixing element (e.g. retaining bracket or an end angle).

Wiring

Please note:

- ▶ Information given in the "[Technical details \[96\]](#)" must be followed.
- ▶ Outputs 13-14, 23-24, 33-34 are safety contacts; output 41-42 is an auxiliary contact (e.g. for display).
- ▶ Auxiliary contact 41-42 should **not** be used for safety circuits!
- ▶ To prevent contact welding, a fuse should be connected before the output contacts (see [Technical details \[96\]](#)).
- ▶ Calculation of the max. cable length l_{\max} in the input circuit:

$$l_{\max} = \frac{R_{l_{\max}}}{R_1 / \text{km}}$$

$R_{l_{\max}}$ = max. overall cable resistance (see [Technical details \[96\]](#))

R_1 / km = cable resistance/km

- ▶ Use copper wire that can withstand 60/75 °C.
- ▶ Sufficient fuse protection must be provided on all output contacts with capacitive and inductive loads.
- ▶ Do not switch low currents using contacts that have been used previously with high currents.
- ▶ When connecting magnetically operated, reed proximity switches, ensure that the max. peak inrush current (on the input circuit) does not overload the proximity switch.
- ▶ On 24 VAC/DC units:
The power supply must comply with the regulations for extra low voltages with safe electrical separation (SELV, PELV) in accordance with VDE 0100, Part 410.
- ▶ Ensure the wiring and EMC requirements of IEC 60204-1 are met.

Safety relays PNOZ X PNOZ X2.8P

Important for detection of shorts across contacts:

As this function for detecting shorts across contacts is not failsafe, it is tested by Pilz during the final control check. If there is a danger of exceeding the cable runs, we recommend the following test after the installation of the device:

1. Unit ready for operation (output contacts closed)
2. Short circuit the test terminals S12, S22 for detecting shorts across the inputs.
3. The unit's fuse must be triggered and the output contacts must open. Cable lengths in the scale of the maximum length can delay the fuse triggering for up to 2 minutes.
4. Reset the fuse: remove the short circuit and switch off the supply voltage for approx. 1 minute.

Preparing for operation

| Supply voltage | AC | DC |
|---|----|----|
| $U_B = 24 \text{ VAC/DC}$; Order no. 777301, 787301 | | |
| $U_B = 24 - 240 \text{ VAC/DC}$; Order no. 777302, 787302 | | |

Safety relays PNOZ X PNOZ X2.8P

| Input circuit | Single-channel | Dual-channel |
|--|----------------|--------------|
| E-STOP without detection of shorts across contacts | | |
| E-STOP with detection of shorts across contacts | | |
| Safety gate without detection of shorts across contacts | | |
| Safety gate with detection of shorts across contacts | | |
| Light guards or safety switch, de- tection of shorts across contacts via ESPE (only when $U_B = 24 \text{ VDC}$); Order no. 777301, 787301) | | |

Safety relays PNOZ X PNOZ X2.8P

| Start circuit | E-STOP wiring, safety gate (single-channel) | E-STOP wiring, safety gate (dual-channel) |
|-----------------------------------|---|---|
| Automatic start | | |
| Manual start | | |
| Feedback loop | Automatic start | Manual start |
| Contacts from external contactors | | |

Legend

- ▶ S1/S2: E-STOP/safety gate switch
- ▶ S3: Reset button
- ▶ ↑: Switch operated
- ▶ : Gate open
- ▶ : Gate closed

Safety relays PNOZ X PNOZ X2.8P

Dimensions in mm

* with spring-loaded terminals

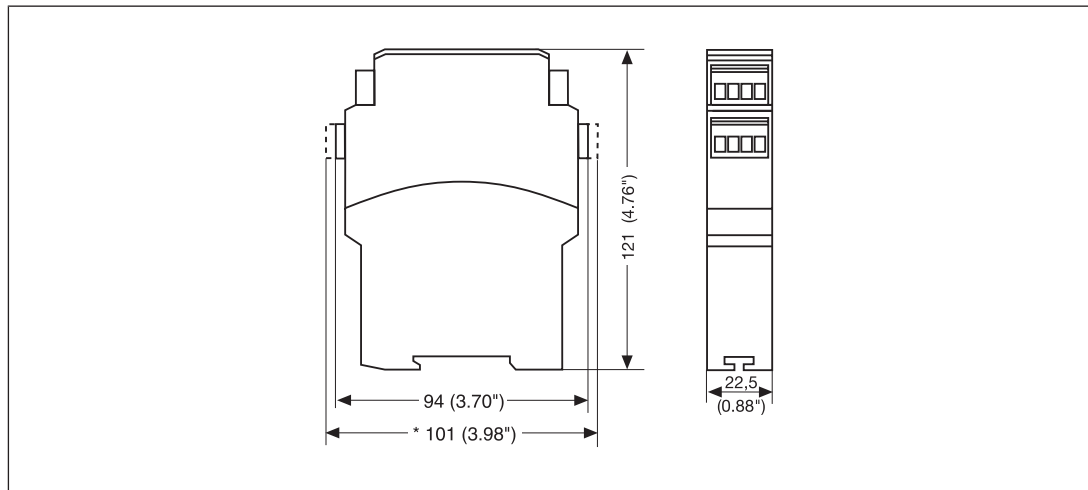

Technical details

Order no. 777301 – 777302

See below for more order numbers

| General | 777301 | 777302 |
|--------------------------------------|--|--|
| Approvals | CCC, CE, EAC (Eurasian), KOSHA, TÜV, cULus Listed | CCC, CE, EAC (Eurasian), KOSHA, TÜV, cULus Listed |
| Electrical data | 777301 | 777302 |
| Supply voltage | | |
| Voltage | 24 V | 24 - 240 V |
| Kind | AC/DC | AC/DC |
| Voltage tolerance | -15 %/+10 % | -15 %/+10 % |
| Output of external power supply (AC) | 5,5 VA | 4,5 VA |
| Output of external power supply (DC) | 2,5 W | 2 W |
| Frequency range AC | 50 - 60 Hz | 50 - 60 Hz |
| Residual ripple DC | 160 % | 160 % |
| Duty cycle | 100 % | 100 % |
| Max. inrush current impulse | | |
| Current pulse, A1 | 1,7 A | – |
| Pulse duration, A1 | 3,3 ms | – |
| Inputs | 777301 | 777302 |
| Number | 2 | 2 |

Safety relays PNOZ X PNOZ X2.8P

| Inputs | 777301 | 777302 |
|---|---------------------|---------------------|
| Voltage at | | |
| Input circuit DC | 24 V | 24 V |
| Start circuit DC | 24 V | 24 V |
| Feedback loop DC | 24 V | 24 V |
| Current at | | |
| Input circuit DC | 30 mA | 25 mA |
| Start circuit DC | 40 mA | 50 mA |
| Feedback loop DC | 40 mA | 50 mA |
| Min. input resistance at power-on | 88 Ohm | 209 Ohm |
| Max. overall cable resistance RI-max | | |
| Single-channel at UB DC | 30 Ohm | 45 Ohm |
| Single-channel at UB AC | 100 Ohm | 45 Ohm |
| Dual-channel without detection of shorts across contacts at UB DC | 50 Ohm | 80 Ohm |
| Dual-channel without detection of shorts across contacts at UB AC | 100 Ohm | 80 Ohm |
| Dual-channel with detection of shorts across contacts at UB DC | 15 Ohm | 15 Ohm |
| Dual-channel with detection of shorts across contacts at UB AC | 15 Ohm | 15 Ohm |
| Relay outputs | 777301 | 777302 |
| Number of output contacts | | |
| Safety contacts (N/O), instantaneous | 3 | 3 |
| Auxiliary contacts (N/C) | 1 | 1 |
| Max. short circuit current IK | 1 kA | 1 kA |
| Utilisation category | | |
| In accordance with the standard | EN 60947-4-1 | EN 60947-4-1 |
| Utilisation category of safety contacts | | |
| AC1 at | 240 V | 240 V |
| Min. current | 0,01 A | 0,01 A |
| Max. current | 6 A | 6 A |
| Max. power | 1500 VA | 1500 VA |
| DC1 at | 24 V | 24 V |
| Min. current | 0,01 A | 0,01 A |
| Max. current | 6 A | 6 A |
| Max. power | 150 W | 150 W |

Safety relays PNOZ X PNOZ X2.8P

| Relay outputs | 777301 | 777302 |
|---|-------------------------------|-------------------------------|
| Utilisation category of auxiliary contacts | | |
| AC1 at | 240 V | 240 V |
| Min. current | 0,01 A | 0,01 A |
| Max. current | 6 A | 6 A |
| Max. power | 1500 VA | 1500 VA |
| DC1 at | 24 V | 24 V |
| Min. current | 0,01 A | 0,01 A |
| Max. current | 6 A | 6 A |
| Max. power | 150 W | 150 W |
| Utilisation category | | |
| In accordance with the standard | EN 60947-5-1 | EN 60947-5-1 |
| Utilisation category of safety contacts | | |
| AC15 at | 230 V | 230 V |
| Max. current | 5 A | 3 A |
| DC13 (6 cycles/min) at | 24 V | 24 V |
| Max. current | 5 A | 4 A |
| Utilisation category of auxiliary contacts | | |
| AC15 at | 230 V | 230 V |
| Max. current | 5 A | 3 A |
| DC13 (6 cycles/min) at | 24 V | 24 V |
| Max. current | 5 A | 4 A |
| Utilisation category in accordance with UL | | |
| Voltage | 240 V AC G.U. (same polarity) | 250 V AC G.U. (same polarity) |
| With current | 6 A | 6 A |
| Voltage | 24 V DC G. P. | 24 V DC G. P. |
| With current | 6 A | 6 A |
| Pilot Duty | R300 | B300, R300 |
| External contact fuse protection, safety contacts | | |
| In accordance with the standard | EN 60947-5-1 | EN 60947-5-1 |
| Max. melting integral | 260 A ² s | 66 A ² s |
| Blow-out fuse, quick | 10 A | 6 A |
| Blow-out fuse, slow | 6 A | 4 A |
| Blow-out fuse, gG | 6 A | 6 A |
| Circuit breaker 24V AC/DC, characteristic B/C | 6 A | 4 A |

Safety relays PNOZ X PNOZ X2.8P

| Relay outputs | 777301 | 777302 |
|---|----------------------|---------------------|
| External contact fuse protection, auxiliary contacts | | |
| Max. melting integral | 160 A ² s | 66 A ² s |
| Blow-out fuse, quick | 10 A | 6 A |
| Blow-out fuse, slow | 6 A | 4 A |
| Blow-out fuse, gG | 6 A | 6 A |
| Circuit breaker 24 V AC/DC, characteristic B/C | 6 A | 4 A |
| Contact material | AgCuNi + 0,2 µm Au | AgCuNi + 0,2 µm Au |
| Conventional thermal current while loading several contacts | 777301 | 777302 |
| Ith per contact at UB AC; AC1: 240 V, DC1: 24 V | | |
| Conv. therm. current with 1 contact | 6 A | 6 A |
| Conv. therm. current with 2 contacts | 4 A | 6 A |
| Conv. therm. current with 3 contacts | 3,5 A | 4,5 A |
| Ith per contact at UB DC; AC1: 240 V, DC1: 24 V | | |
| Conv. therm. current with 1 contact | 6 A | 6 A |
| Conv. therm. current with 2 contacts | 6 A | 6 A |
| Conv. therm. current with 3 contacts | 5 A | 4,5 A |
| Times | 777301 | 777302 |
| Switch-on delay | | |
| With automatic start typ. | 250 ms | 340 ms |
| With automatic start max. | 450 ms | 400 ms |
| With automatic start after power on typ. | 250 ms | 600 ms |
| With automatic start after power on max. | 450 ms | 800 ms |
| With manual start typ. | 125 ms | 180 ms |
| With manual start max. | 450 ms | 400 ms |

Safety relays PNOZ X PNOZ X2.8P

| Times | 777301 | 777302 |
|---|--|--|
| Delay-on de-energisation | | |
| With E-STOP typ. | 15 ms | 10 ms |
| With E-STOP max. | 30 ms | 20 ms |
| With power failure typ. | 60 ms | – |
| With power failure max. | 100 ms | – |
| With power failure typ. UB 240 V – | | 1100 ms |
| With power failure max. UB 240 V | – | 1500 ms |
| With power failure typ. UB 24 V – | | 180 ms |
| With power failure max. UB 24 V – | | 230 ms |
| Recovery time at max. switching frequency 1/s | | |
| After E-STOP | 50 ms | 50 ms |
| After power failure | 200 ms | 1500 ms |
| Supply interruption before de-energisation | | |
| | 20 ms | 20 ms |
| Simultaneity, channel 1 and 2 max. | | |
| | ∞ | ∞ |
| Environmental data | 777301 | 777302 |
| Climatic suitability | | |
| | EN 60068-2-78 | EN 60068-2-78 |
| Ambient temperature | | |
| Temperature range | -35 - 55 °C | -10 - 55 °C |
| Storage temperature | | |
| Temperature range | -40 - 85 °C | -40 - 85 °C |
| Climatic suitability | | |
| Humidity | 93 % r. h. at 40 °C | 93 % r. h. at 40 °C |
| Condensation during operation | | |
| | Not permitted | Not permitted |
| EMC | | |
| | EN 60947-5-1, EN 61000-6-2, EN 61000-6-4, EN 61326-3-1 | EN 60947-5-1, EN 61000-6-2, EN 61000-6-4, EN 61326-3-1 |
| Vibration | | |
| In accordance with the standard | EN 60068-2-6 | EN 60068-2-6 |
| Frequency | 10 - 55 Hz | 10 - 55 Hz |
| Amplitude | 0,35 mm | 0,35 mm |
| Airgap creepage | | |
| In accordance with the standard | EN 60947-1 | EN 60947-1 |
| Overvoltage category | III / II | III / II |
| Pollution degree | 2 | 2 |
| Rated insulation voltage | | |
| | 250 V | 250 V |
| Rated impulse withstand voltage | | |
| | 4 kV | 4 kV |

Safety relays PNOZ X PNOZ X2.8P

| Environmental data | 777301 | 777302 |
|---|---|---|
| Protection type | | |
| Mounting area (e.g. control cabinet) | IP54 | IP54 |
| Housing | IP40 | IP40 |
| Terminals | IP20 | IP20 |
| Mechanical data | 777301 | 777302 |
| Mounting position | Any | Any |
| Mechanical life | 10,000,000 cycles | 10,000,000 cycles |
| Material | | |
| Bottom | PPO UL 94 V0 | PPO UL 94 V0 |
| Front | ABS UL 94 V0 | ABS UL 94 V0 |
| Top | PPO UL 94 V0 | PPO UL 94 V0 |
| Connection type | Screw terminal | Screw terminal |
| Mounting type | plug-in | plug-in |
| Conductor cross section with screw terminals | | |
| 1 core flexible | 0,25 - 2,5 mm², 24 - 12 AWG | 0,25 - 2,5 mm², 24 - 12 AWG |
| 2 core with the same cross section, flexible with crimp connectors, no plastic sleeve | 0,25 - 1 mm², 24 - 16 AWG | 0,25 - 1 mm², 24 - 16 AWG |
| 2 core with the same cross section, flexible without crimp connectors or with TWIN crimp connectors | 0,2 - 1,5 mm², 24 - 16 AWG | 0,2 - 1,5 mm², 24 - 16 AWG |
| Torque setting with screw terminals | 0,5 Nm | 0,5 Nm |
| Dimensions | | |
| Height | 94 mm | 94 mm |
| Width | 22,5 mm | 22,5 mm |
| Depth | 121 mm | 121 mm |
| Weight | 190 g | 210 g |

Where standards are undated, the 2014-07 latest editions shall apply.

Safety relays PNOZ X PNOZ X2.8P

Order no. 787301 – 787302

| General | 787301 | 787302 |
|--------------------------------------|--|--|
| Approvals | CCC, CE, EAC (Eurasian), KOSHA, TÜV, cULus Listed | CCC, CE, EAC (Eurasian), KOSHA, TÜV, cULus Listed |
| Electrical data | 787301 | 787302 |
| Supply voltage | | |
| Voltage | 24 V | 24 - 240 V |
| Kind | AC/DC | AC/DC |
| Voltage tolerance | -15 %/+10 % | -15 %/+10 % |
| Output of external power supply (AC) | 5,5 VA | 4,5 VA |
| Output of external power supply (DC) | 2,5 W | 2 W |
| Frequency range AC | 50 - 60 Hz | 50 - 60 Hz |
| Residual ripple DC | 160 % | 160 % |
| Duty cycle | 100 % | 100 % |
| Max. inrush current impulse | | |
| Current pulse, A1 | 1,7 A | – |
| Pulse duration, A1 | 3,3 ms | – |
| Inputs | 787301 | 787302 |
| Number | 2 | 2 |
| Voltage at | | |
| Input circuit DC | 24 V | 24 V |
| Start circuit DC | 24 V | 24 V |
| Feedback loop DC | 24 V | 24 V |
| Current at | | |
| Input circuit DC | 30 mA | 25 mA |
| Start circuit DC | 40 mA | 50 mA |
| Feedback loop DC | 40 mA | 50 mA |
| Min. input resistance at power-on | 88 Ohm | 209 Ohm |

Safety relays PNOZ X PNOZ X2.8P

| Inputs | 787301 | 787302 |
|---|--------------|--------------|
| Max. overall cable resistance RI-max | | |
| Single-channel at UB DC | 30 Ohm | 45 Ohm |
| Single-channel at UB AC | 100 Ohm | 45 Ohm |
| Dual-channel without detection of shorts across contacts at UB DC | 50 Ohm | 80 Ohm |
| Dual-channel without detection of shorts across contacts at UB AC | 100 Ohm | 80 Ohm |
| Dual-channel with detection of shorts across contacts at UB DC | 15 Ohm | 15 Ohm |
| Dual-channel with detection of shorts across contacts at UB AC | 15 Ohm | 15 Ohm |
| Relay outputs | 787301 | 787302 |
| Number of output contacts | | |
| Safety contacts (N/O), instantaneous | 3 | 3 |
| Auxiliary contacts (N/C) | 1 | 1 |
| Max. short circuit current IK | 1 kA | 1 kA |
| Utilisation category | | |
| In accordance with the standard | EN 60947-4-1 | EN 60947-4-1 |
| Utilisation category of safety contacts | | |
| AC1 at | 240 V | 240 V |
| Min. current | 0,01 A | 0,01 A |
| Max. current | 6 A | 6 A |
| Max. power | 1500 VA | 1500 VA |
| DC1 at | 24 V | 24 V |
| Min. current | 0,01 A | 0,01 A |
| Max. current | 6 A | 6 A |
| Max. power | 150 W | 150 W |
| Utilisation category of auxiliary contacts | | |
| AC1 at | 240 V | 240 V |
| Min. current | 0,01 A | 0,01 A |
| Max. current | 6 A | 6 A |
| Max. power | 1500 VA | 1500 VA |
| DC1 at | 24 V | 24 V |
| Min. current | 0,01 A | 0,01 A |
| Max. current | 6 A | 6 A |
| Max. power | 150 W | 150 W |

Safety relays PNOZ X PNOZ X2.8P

| Relay outputs | 787301 | 787302 |
|--|--------------------------------------|--------------------------------------|
| Utilisation category | | |
| In accordance with the standard | EN 60947-5-1 | EN 60947-5-1 |
| Utilisation category of safety contacts | | |
| AC15 at | 230 V | 230 V |
| Max. current | 5 A | 3 A |
| DC13 (6 cycles/min) at | 24 V | 24 V |
| Max. current | 5 A | 4 A |
| Utilisation category of auxiliary contacts | | |
| AC15 at | 230 V | 230 V |
| Max. current | 5 A | 3 A |
| DC13 (6 cycles/min) at | 24 V | 24 V |
| Max. current | 5 A | 4 A |
| Utilisation category in accordance with UL | | |
| Voltage | 240 V AC G.U. (same polarity) | 250 V AC G.U. (same polarity) |
| With current | 6 A | 6 A |
| Voltage | 24 V DC G. P. | 24 V DC G. P. |
| With current | 6 A | 6 A |
| Pilot Duty | R300 | B300, R300 |
| External contact fuse protection, safety contacts | | |
| In accordance with the standard | EN 60947-5-1 | EN 60947-5-1 |
| Max. melting integral | 260 A²s | 66 A²s |
| Blow-out fuse, quick | 10 A | 6 A |
| Blow-out fuse, slow | 6 A | 4 A |
| Blow-out fuse, gG | 6 A | 6 A |
| Circuit breaker 24V AC/DC, characteristic B/C | 6 A | 4 A |
| External contact fuse protection, auxiliary contacts | | |
| Max. melting integral | 160 A²s | 66 A²s |
| Blow-out fuse, quick | 10 A | 6 A |
| Blow-out fuse, slow | 6 A | 4 A |
| Blow-out fuse, gG | 6 A | 6 A |
| Circuit breaker 24 V AC/DC, characteristic B/C | 6 A | 4 A |
| Contact material | AgCuNi + 0,2 µm Au | AgCuNi + 0,2 µm Au |

Safety relays PNOZ X PNOZ X2.8P

| Conventional thermal current while loading several contacts | 787301 | 787302 |
|--|---------------|----------------|
| Ith per contact at UB AC; AC1: 240 V, DC1: 24 V | | |
| Conv. therm. current with 1 contact | 6 A | 6 A |
| Conv. therm. current with 2 contacts | 4 A | 6 A |
| Conv. therm. current with 3 contacts | 3,5 A | 4,5 A |
| Ith per contact at UB DC; AC1: 240 V, DC1: 24 V | | |
| Conv. therm. current with 1 contact | 6 A | 6 A |
| Conv. therm. current with 2 contacts | 6 A | 6 A |
| Conv. therm. current with 3 contacts | 5 A | 4,5 A |
| Times | 787301 | 787302 |
| Switch-on delay | | |
| With automatic start typ. | 250 ms | 340 ms |
| With automatic start max. | 450 ms | 400 ms |
| With automatic start after power on typ. | 250 ms | 600 ms |
| With automatic start after power on max. | 450 ms | 800 ms |
| With manual start typ. | 125 ms | 180 ms |
| With manual start max. | 450 ms | 400 ms |
| Delay-on de-energisation | | |
| With E-STOP typ. | 15 ms | 10 ms |
| With E-STOP max. | 30 ms | 20 ms |
| With power failure typ. | 60 ms | – |
| With power failure max. | 100 ms | – |
| With power failure typ. UB 240 V – | | 1100 ms |
| With power failure max. UB 240 V | – | 1500 ms |
| With power failure typ. UB 24 V – | | 180 ms |
| With power failure max. UB 24 V – | | 230 ms |
| Recovery time at max. switching frequency 1/s | | |
| After E-STOP | 50 ms | 50 ms |
| After power failure | 200 ms | 1500 ms |
| Supply interruption before de-energisation | 20 ms | 20 ms |
| Simultaneity, channel 1 and 2 max. | ∞ | ∞ |

Safety relays PNOZ X PNOZ X2.8P

| Environmental data | 787301 | 787302 |
|---|--|--|
| Climatic suitability | EN 60068-2-78 | EN 60068-2-78 |
| Ambient temperature | | |
| Temperature range | -35 - 55 °C | -10 - 55 °C |
| Storage temperature | | |
| Temperature range | -40 - 85 °C | -40 - 85 °C |
| Climatic suitability | | |
| Humidity | 93 % r. h. at 40 °C | 93 % r. h. at 40 °C |
| Condensation during operation | Not permitted | Not permitted |
| EMC | EN 60947-5-1, EN 61000-6-2, EN 61000-6-4, EN 61326-3-1 | EN 60947-5-1, EN 61000-6-2, EN 61000-6-4, EN 61326-3-1 |
| Vibration | | |
| In accordance with the standard | EN 60068-2-6 | EN 60068-2-6 |
| Frequency | 10 - 55 Hz | 10 - 55 Hz |
| Amplitude | 0,35 mm | 0,35 mm |
| Airgap creepage | | |
| In accordance with the standard | EN 60947-1 | EN 60947-1 |
| Overvoltage category | III / II | III / II |
| Pollution degree | 2 | 2 |
| Rated insulation voltage | 250 V | 250 V |
| Rated impulse withstand voltage | 4 kV | 4 kV |
| Protection type | | |
| Mounting area (e.g. control cabinet) | IP54 | IP54 |
| Housing | IP40 | IP40 |
| Terminals | IP20 | IP20 |
| Mechanical data | 787301 | 787302 |
| Mounting position | Any | Any |
| Mechanical life | 10,000,000 cycles | 10,000,000 cycles |
| Material | | |
| Bottom | PPO UL 94 V0 | PPO UL 94 V0 |
| Front | ABS UL 94 V0 | ABS UL 94 V0 |
| Top | PPO UL 94 V0 | PPO UL 94 V0 |
| Connection type | Cage clamp terminal | Cage clamp terminal |
| Mounting type | plug-in | plug-in |
| Conductor cross section with spring-loaded terminals: Flexible with/without crimp connector | 0,2 - 1,5 mm ² , 24 - 16 AWG | 0,2 - 1,5 mm ² , 24 - 16 AWG |
| Spring-loaded terminals: Terminal points per connection | 2 | 2 |
| Stripping length with spring-loaded terminals | 8 mm | 8 mm |

Safety relays PNOZ X PNOZ X2.8P

| Mechanical data | 787301 | 787302 |
|-----------------|---------|---------|
| Dimensions | | |
| Height | 101 mm | 101 mm |
| Width | 22,5 mm | 22,5 mm |
| Depth | 121 mm | 121 mm |
| Weight | 190 g | 210 g |

Where standards are undated, the 2014-07 latest editions shall apply.

Safety characteristic data

| Operating Mode | EN ISO 13849-1: 2015 | EN ISO 13849-1: 2015 | EN 62061 SIL CL | EN 62061 PFH _D [1/h] | IEC 61511 SIL | IEC 61511 PFD | EN ISO 13849-1: 2015 T _M [year] |
|----------------|----------------------|----------------------|-----------------|---------------------------------|---------------|---------------|--|
| | PL | Category | | | | | |
| – | PL e | Cat. 4 | SIL CL 3 | 2,31E-09 | SIL 3 | 2,03E-06 | 20 |

All the units used within a safety function must be considered when calculating the safety characteristic data.

Supplementary data

The PFH value depends on the switching frequency and the load on the relay output. If the service life graphs are not accessible, the stated PFH value can be used irrespective of the switching frequency and the load, as the PFH value already considers the relay's B10d value as well as the failure rates of the other components.

Safety relays PNOZ X PNOZ X2.8P

Service life graph

The service life graphs indicate the number of cycles from which failures due to wear must be expected. The wear is mainly caused by the electrical load; the mechanical load is negligible.

Unit types with UB 24 VAC/DC

- ▶ U_B : 24 VAC/DC; Order no. 777301, 787301

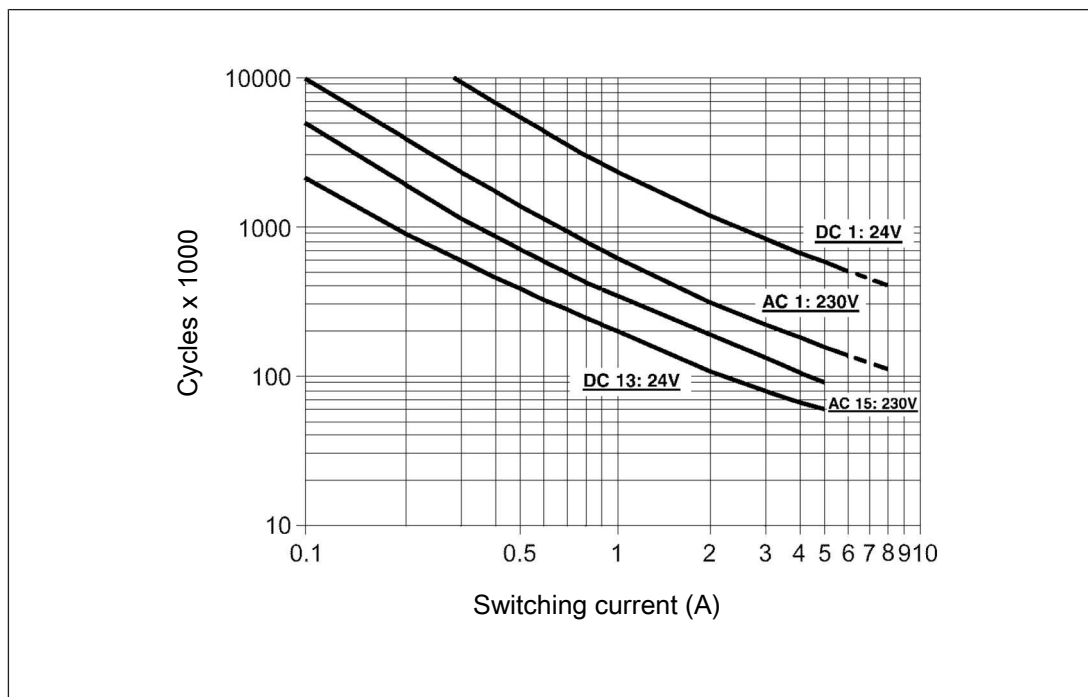

Fig.: Service life graphs at 24 V DC and 230 V AC

Safety relays PNOZ X PNOZ X2.8P

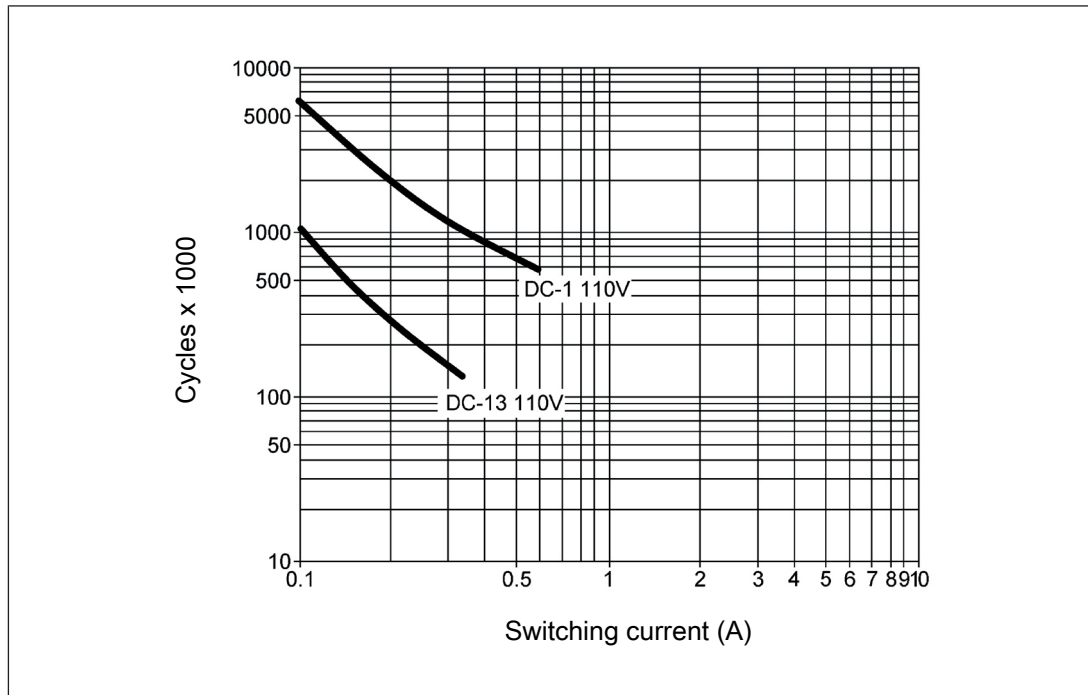

Fig.: Service life graphs at 110 V DC

Example

- ▶ Inductive load: 0.2 A
- ▶ Utilisation category: AC15
- ▶ Contact service life: 2 000 000 cycles

Provided the application to be implemented requires fewer than 2 000 000 cycles, the PFH value (see [Technical details \[96\]](#)) can be used in the calculation.

To increase the service life, sufficient spark suppression must be provided on all output contacts. With capacitive loads, any power surges that occur must be noted. With DC contactors, use flywheel diodes for spark suppression.

Safety relays PNOZ X PNOZ X2.8P

Unit types with UB 24-240 VAC/DC

▶ U_B : 24 – 240 VAC/DC; Order no. 777302, 787302

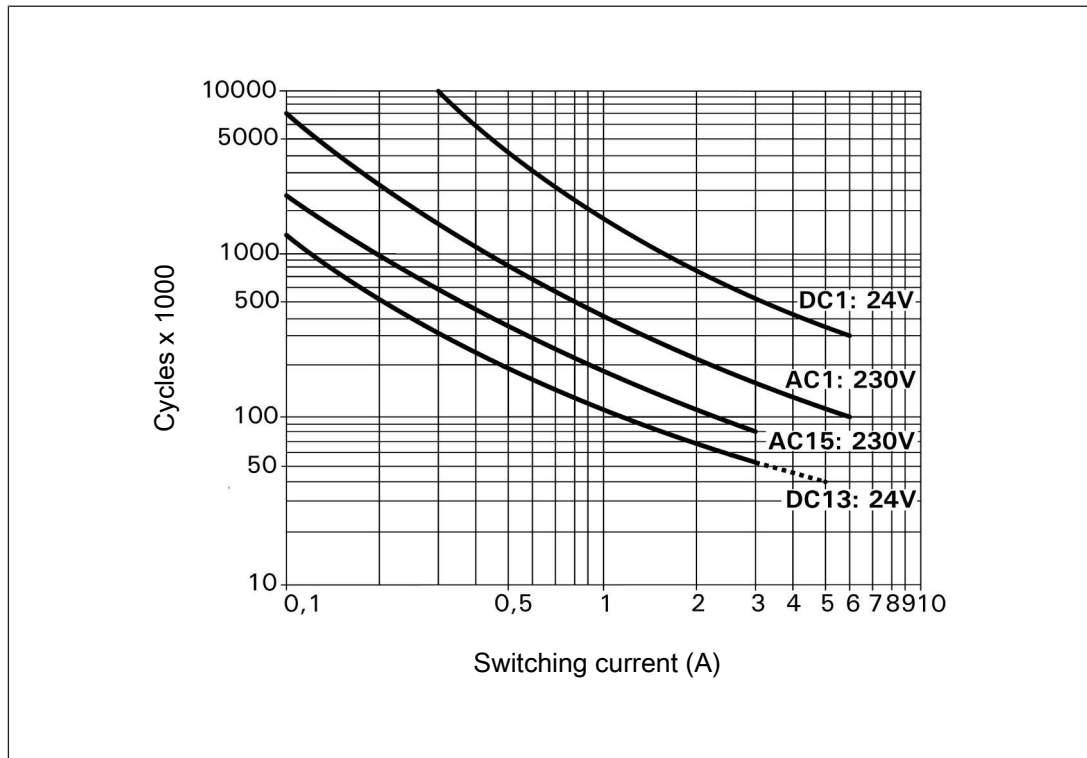

Fig.: Service life graphs at 24 V DC and 230 V AC

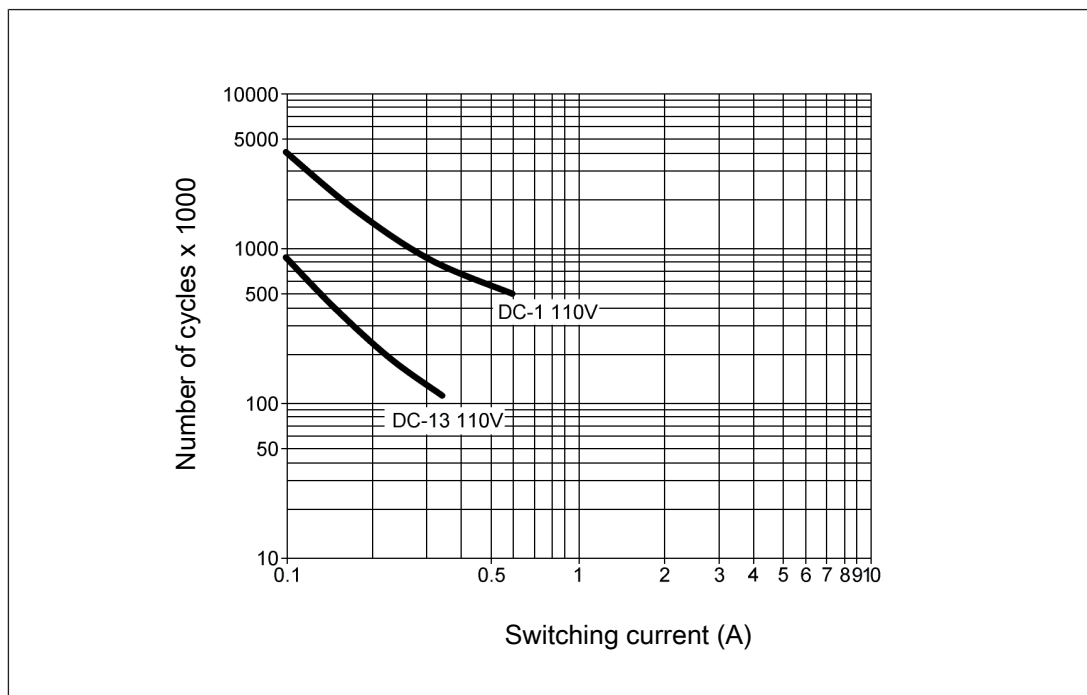

Fig.: Service life graphs at 110 V DC

Safety relays PNOZ X PNOZ X2.8P

Example

- ▶ Inductive load: 0.2 A
- ▶ Utilisation category: AC15
- ▶ Contact service life: 1 000 000 cycles

Provided the application to be implemented requires fewer than 1 000 000 cycles, the PFH value (see [Technical details \[📖 96\]](#)) can be used in the calculation.

To increase the service life, sufficient spark suppression must be provided on all relay contacts. With capacitive loads, any power surges that occur must be noted. With DC contactors, use flywheel diodes for spark suppression.

Order reference

| Product type | Features | Connection type | Order no. |
|--------------|------------------|-------------------------|-----------|
| PNOZ X2.8P | 24 VAC/DC | Screw terminals | 777 301 |
| PNOZ X2.8P C | 24 VAC/DC | Spring-loaded terminals | 787 301 |
| PNOZ X2.8P | 24 - 240 V AC/DC | Screw terminals | 777 302 |
| PNOZ X2.8P C | 24 - 240 V AC/DC | Spring-loaded terminals | 787 302 |

Safety relays PNOZ X PNOZ X2.9P

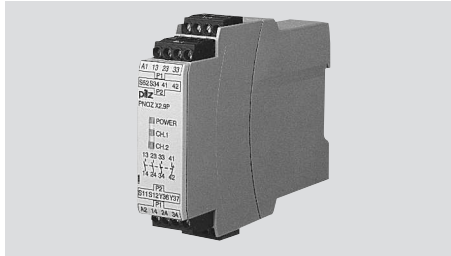

Unit features

- ▶ Positive-guided relay outputs:
 - 3 safety contacts (N/O), instantaneous
 - 1 auxiliary contact (N/C), instantaneous
- ▶ Connection options for:
 - E-STOP pushbuttons
 - Safety gate limit switches
 - Start button
 - Light guards and safety switches
- ▶ LED display for:
 - Supply voltage
 - Switch status of the safety contacts
- ▶ Plug-in connection terminals (either spring-loaded terminal or screw terminal)
- ▶ See order reference for unit types

Safety relays PNOZ X PNOZ X2.9P

Block diagram/terminal configuration

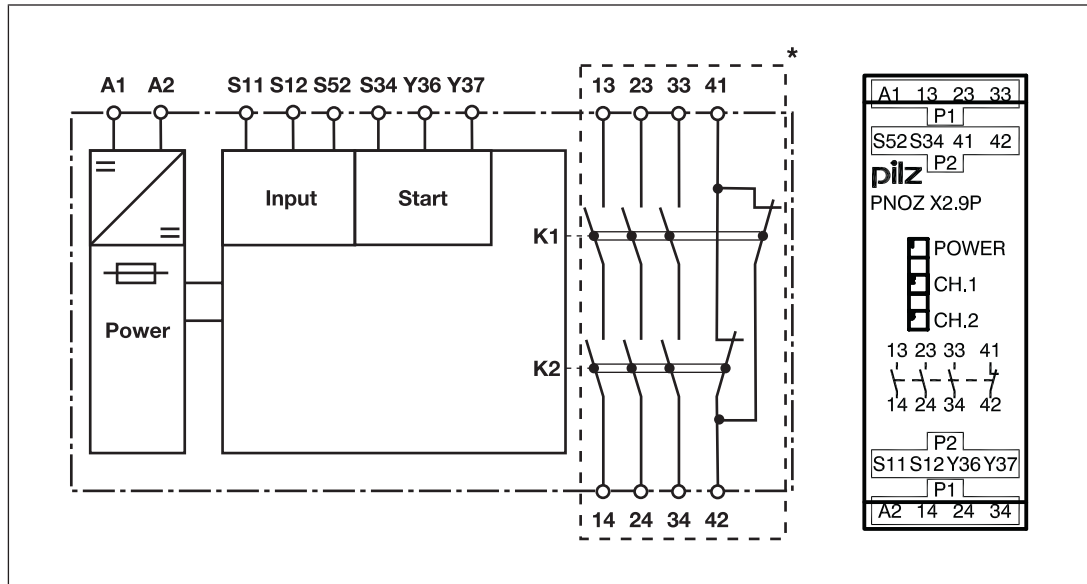

*Insulation between the non-marked area and the relay contacts: Basic insulation (over-voltage category III), Protective separation (overvoltage category II)

Function Description

The safety relay PNOZ X2.9P provides a safety-oriented interruption of a safety circuit. When supply voltage is supplied the "POWER" LED is lit. The unit is ready for operation when the start circuit S12-S34 is closed.

- ▶ Input circuit is closed (e.g. E-STOP pushbutton not operated):
 - The LEDs "CH.1" and "CH.2" are lit.
 - Safety contacts 13-14, 23-24 and 33-34 are closed, auxiliary contact 41-42 is open. The unit is active.
- ▶ Input circuit is opened (e.g. E-STOP pushbutton operated):
 - The LEDs "CH.1" and "CH.2" go out.
 - Safety contacts 13-14, 23-24 and 33-34 are opened redundantly, auxiliary contact 41-42 is closed.

Operating modes

- ▶ Single-channel operation: No redundancy in the input circuit, earth faults in the start and input circuit are detected.
- ▶ Dual-channel operation without detection of shorts across contacts: Redundant input circuit, detects PNOZ X2.9P
 - earth faults in the start and input circuit,
 - short circuits in the input circuit.

Safety relays PNOZ X PNOZ X2.9P

- ▶ Automatic start: Unit is active once the input circuit has been closed.
- ▶ Manual start: Unit is active once the input circuit and the start circuit are closed.
- ▶ Monitored start: Unit is active once the input circuit is closed and once the start circuit is closed after the waiting period has elapsed (see [Technical details \[118\]](#)).
- ▶ Increase in the number of available contacts by connecting contact expander modules or external contactors/relays.

Timing diagram

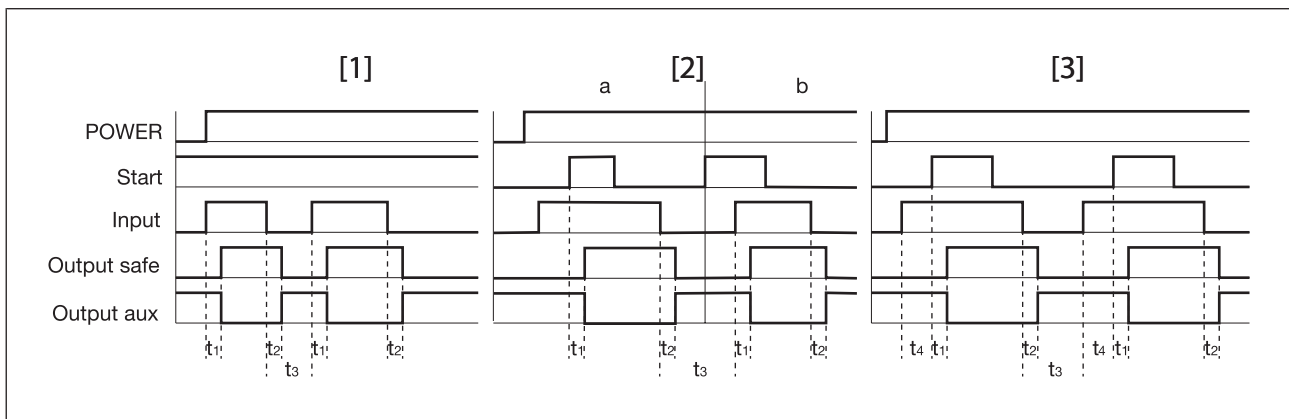

Legend

- ▶ Power: Supply voltage
- ▶ Start: Start circuit
- ▶ Input: Input circuit
- ▶ Output safe: Safety contacts
- ▶ Output aux: Auxiliary contact
- ▶ [1]: Automatic start
- ▶ [2]: Manual start
- ▶ [3]: Monitored start
- ▶ a: Input circuit closes before start circuit
- ▶ b: Start circuit closes before input circuit
- ▶ t_1 : Switch-on delay
- ▶ t_2 : Delay-on de-energisation
- ▶ t_3 : Recovery time
- ▶ t_4 : Waiting period with a monitored start

Safety relays PNOZ X PNOZ X2.9P

Installation

- ▶ The unit should be installed in a control cabinet with a protection type of at least IP54.
- ▶ Use the notch on the rear of the unit to attach it to a DIN rail.
- ▶ Ensure the unit is mounted securely on a vertical DIN rail (35 mm) by using a fixing element (e.g. retaining bracket or an end angle).

Wiring

Please note:

- ▶ Information given in the "[Technical details \[118\]](#)" must be followed.
- ▶ Outputs 13-14, 23-24, 33-34 are safety contacts; output 41-42 is an auxiliary contact (e.g. for display).
- ▶ Auxiliary contact 41-42 should **not** be used for safety circuits!
- ▶ To prevent contact welding, a fuse should be connected before the output contacts (see [Technical details \[118\]](#)).
- ▶ Calculation of the max. cable length l_{\max} in the input circuit:

$$l_{\max} = \frac{R_{l_{\max}}}{R_l / \text{km}}$$

$R_{l_{\max}}$ = max. overall cable resistance (see [Technical details \[118\]](#))

R_l / km = cable resistance/km

- ▶ Use copper wire that can withstand 60/75 °C.
- ▶ Sufficient fuse protection must be provided on all output contacts with capacitive and inductive loads.
- ▶ Do not switch low currents using contacts that have been used previously with high currents.
- ▶ When connecting magnetically operated, reed proximity switches, ensure that the max. peak inrush current (on the input circuit) does not overload the proximity switch.
- ▶ The power supply must comply with the regulations for extra low voltages with protective electrical separation (SELV, PELV) in accordance with VDE 0100, Part 410.
- ▶ Ensure the wiring and EMC requirements of IEC 60204-1 are met.

Safety relays PNOZ X PNOZ X2.9P

Preparing for operation

| Supply voltage | AC | DC |
|--|----------------|--------------|
| | | |
| Input circuit | Single-channel | Dual-channel |
| E-STOP without detection of shorts across contacts | | |
| Safety gate without detection of shorts across contacts | | |
| Light guard or safety switch, de- tection of shorts across contacts via ESPE | | |

Safety relays PNOZ X PNOZ X2.9P

| Start circuit | E-STOP wiring (single-channel) safety gate (single-channel) | E-STOP wiring (dual-channel), safety gate (dual-channel) |
|-----------------------------------|---|--|
| Automatic start | | |
| Manual start | | |
| Monitored start | | |
| Feedback loop | Automatic start | Manual start/monitored start |
| Contacts from external contactors | | |

Legend

- ▶ S1/S2: E-STOP/safety gate switch
- ▶ S3: Reset button
- ▶ ↑: Switch operated
- ▶ : Gate open
- ▶ : Gate closed

Safety relays PNOZ X PNOZ X2.9P

Dimensions in mm

* with spring-loaded terminals

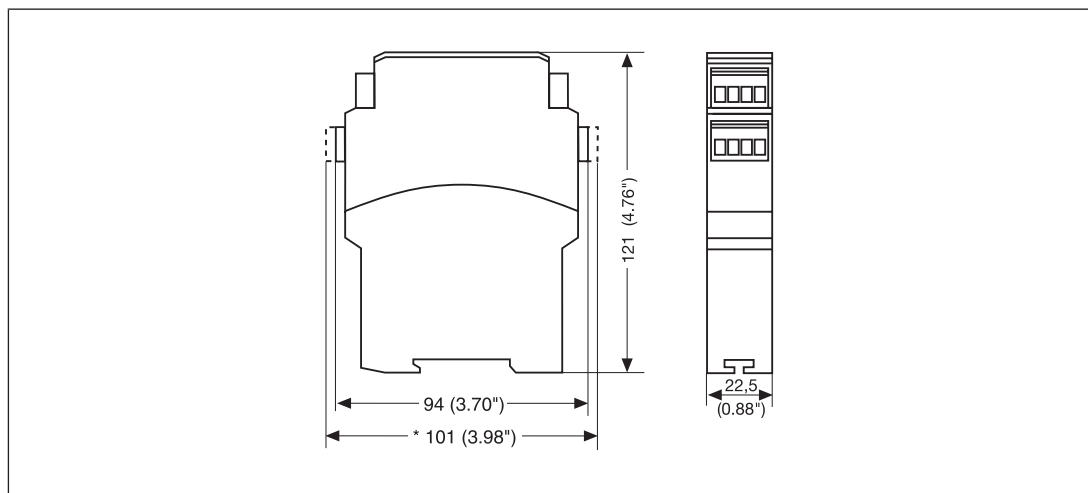

Technical details

| General | 777300 | 787300 |
|--------------------------------------|--|--|
| Approvals | CCC, CE, EAC (Eurasian), TÜV, cULus Listed | CCC, CE, EAC (Eurasian), TÜV, cULus Listed |
| Electrical data | 777300 | 787300 |
| Supply voltage | | |
| Voltage | 24 V | 24 V |
| Kind | DC | DC |
| Voltage tolerance | -15 %/+10 % | -15 %/+10 % |
| Output of external power supply (DC) | 2 W | 2 W |
| Residual ripple DC | 160 % | 160 % |
| Duty cycle | 100 % | 100 % |
| Max. inrush current impulse | | |
| Current pulse, A1 | 1,7 A | 1,7 A |
| Pulse duration, A1 | 3,3 ms | 3,3 ms |
| Inputs | 777300 | 787300 |
| Number | 2 | 2 |
| Voltage at | | |
| Input circuit DC | 24 V | 24 V |
| Start circuit DC | 24 V | 24 V |
| Feedback loop DC | 24 V | 24 V |

Safety relays PNOZ X PNOZ X2.9P

| Inputs | 777300 | 787300 |
|---|---------------------|---------------------|
| Current at | | |
| Input circuit DC | 30 mA | 30 mA |
| Start circuit DC | 60 mA | 60 mA |
| Feedback loop DC | 60 mA | 60 mA |
| Min. input resistance at power-on | 205 Ohm | 205 Ohm |
| Max. overall cable resistance RI-max | | |
| Single-channel at UB DC | 50 Ohm | 50 Ohm |
| Dual-channel without detection of shorts across contacts at UB DC | 80 Ohm | 80 Ohm |
| Relay outputs | 777300 | 787300 |
| Number of output contacts | | |
| Safety contacts (N/O), instantaneous | 3 | 3 |
| Auxiliary contacts (N/C) | 1 | 1 |
| Max. short circuit current IK | 1 kA | 1 kA |
| Utilisation category | | |
| In accordance with the standard | EN 60947-4-1 | EN 60947-4-1 |
| Utilisation category of safety contacts | | |
| AC1 at | 240 V | 240 V |
| Min. current | 0,01 A | 0,01 A |
| Max. current | 6 A | 6 A |
| Max. power | 1500 VA | 1500 VA |
| DC1 at | 24 V | 24 V |
| Min. current | 0,01 A | 0,01 A |
| Max. current | 6 A | 6 A |
| Max. power | 150 W | 150 W |
| Utilisation category of auxiliary contacts | | |
| AC1 at | 240 V | 240 V |
| Min. current | 0,01 A | 0,01 A |
| Max. current | 6 A | 6 A |
| Max. power | 1500 VA | 1500 VA |
| DC1 at | 24 V | 24 V |
| Min. current | 0,01 A | 0,01 A |
| Max. current | 6 A | 6 A |
| Max. power | 150 W | 150 W |
| Utilisation category | | |
| In accordance with the standard | EN 60947-5-1 | EN 60947-5-1 |

Safety relays PNOZ X PNOZ X2.9P

| Relay outputs | 777300 | 787300 |
|--|--------------------------------------|--------------------------------------|
| Utilisation category of safety contacts | | |
| AC15 at | 230 V | 230 V |
| Max. current | 3 A | 3 A |
| DC13 (6 cycles/min) at | 24 V | 24 V |
| Max. current | 4 A | 4 A |
| Utilisation category of auxiliary contacts | | |
| AC15 at | 230 V | 230 V |
| Max. current | 3 A | 3 A |
| DC13 (6 cycles/min) at | 24 V | 24 V |
| Max. current | 4 A | 4 A |
| Utilisation category in accordance with UL | | |
| Voltage | 250 V AC G.U. (same polarity) | 250 V AC G.U. (same polarity) |
| With current | 6 A | 6 A |
| Voltage | 24 V DC G. U. | 24 V DC G. U. |
| With current | 6 A | 6 A |
| Pilot Duty | B300, R300 | B300, R300 |
| External contact fuse protection, safety contacts | | |
| In accordance with the standard | EN 60947-5-1 | EN 60947-5-1 |
| Max. melting integral | 66 A²s | 66 A²s |
| Blow-out fuse, quick | 6 A | 6 A |
| Blow-out fuse, slow | 4 A | 4 A |
| Blow-out fuse, gG | 6 A | 6 A |
| Circuit breaker 24V AC/DC, characteristic B/C | 4 A | 4 A |
| External contact fuse protection, auxiliary contacts | | |
| Max. melting integral | 66 A²s | 66 A²s |
| Blow-out fuse, quick | 6 A | 6 A |
| Blow-out fuse, slow | 4 A | 4 A |
| Blow-out fuse, gG | 6 A | 6 A |
| Circuit breaker 24 V AC/DC, characteristic B/C | 4 A | 4 A |
| Contact material | AgSnO₂ + 0,2 µm Au | AgSnO₂ + 0,2 µm Au |

Safety relays PNOZ X PNOZ X2.9P

| | | |
|--|---------------|---------------|
| Conventional thermal current while loading several contacts | 777300 | 787300 |
| I _{th} per contact at UB DC; AC1: 240 V, DC1: 24 V | | |
| Conv. therm. current with 1 contact | 6 A | 6 A |
| Conv. therm. current with 2 contacts | 6 A | 6 A |
| Conv. therm. current with 3 contacts | 4,5 A | 4,5 A |
| Times | 777300 | 787300 |
| Switch-on delay | | |
| With automatic start typ. | 200 ms | 200 ms |
| With automatic start max. | 400 ms | 400 ms |
| With automatic start after power on typ. | 200 ms | 200 ms |
| With automatic start after power on max. | 400 ms | 400 ms |
| With manual start typ. | 100 ms | 100 ms |
| With manual start max. | 400 ms | 400 ms |
| With monitored start typ. | 30 ms | 30 ms |
| With monitored start max. | 50 ms | 50 ms |
| Delay-on de-energisation | | |
| With E-STOP typ. | 10 ms | 10 ms |
| With E-STOP max. | 20 ms | 20 ms |
| With power failure typ. | 70 ms | 70 ms |
| With power failure max. | 120 ms | 120 ms |
| Recovery time at max. switching frequency 1/s | | |
| After E-STOP | 50 ms | 50 ms |
| After power failure | 150 ms | 150 ms |
| Waiting period with a monitored start | 200 ms | 200 ms |
| Min. start pulse duration with a monitored start | 30 ms | 30 ms |
| Supply interruption before de-energisation | 20 ms | 20 ms |
| Simultaneity, channel 1 and 2 max. | ∞ | ∞ |
| Environmental data | 777300 | 787300 |
| Climatic suitability | EN 60068-2-78 | EN 60068-2-78 |
| Ambient temperature | | |
| Temperature range | -10 - 55 °C | -10 - 55 °C |
| Storage temperature | | |
| Temperature range | -40 - 85 °C | -40 - 85 °C |

Safety relays PNOZ X PNOZ X2.9P

| Environmental data | 777300 | 787300 |
|---|--|--|
| Climatic suitability | | |
| Humidity | 93 % r. h. at 40 °C | 93 % r. h. at 40 °C |
| Condensation during operation | Not permitted | Not permitted |
| EMC | EN 60947-5-1, EN 61000-6-2, EN 61326-3-1 | EN 60947-5-1, EN 61000-6-2, EN 61326-3-1 |
| Vibration | | |
| In accordance with the standard | EN 60068-2-6 | EN 60068-2-6 |
| Frequency | 10 - 55 Hz | 10 - 55 Hz |
| Amplitude | 0,35 mm | 0,35 mm |
| Airgap creepage | | |
| In accordance with the standard | EN 60947-1 | EN 60947-1 |
| Overvoltage category | III / II | III / II |
| Pollution degree | 2 | 2 |
| Rated insulation voltage | 250 V | 250 V |
| Rated impulse withstand voltage | 4 kV | 4 kV |
| Protection type | | |
| Mounting area (e.g. control cabinet) | IP54 | IP54 |
| Housing | IP40 | IP40 |
| Terminals | IP20 | IP20 |
| Mechanical data | 777300 | 787300 |
| Mounting position | Any | Any |
| Mechanical life | 10,000,000 cycles | 10,000,000 cycles |
| Material | | |
| Bottom | PPO UL 94 V0 | PPO UL 94 V0 |
| Front | ABS UL 94 V0 | ABS UL 94 V0 |
| Top | PPO UL 94 V0 | PPO UL 94 V0 |
| Connection type | Screw terminal | Cage clamp terminal |
| Mounting type | plug-in | plug-in |
| Conductor cross section with screw terminals | | |
| 1 core flexible | 0,25 - 2,5 mm ² , 24 - 12 AWG | – |
| 2 core with the same cross section, flexible with crimp connectors, no plastic sleeve | 0,25 - 1 mm ² , 24 - 16 AWG | – |
| 2 core with the same cross section, flexible without crimp connectors or with TWIN crimp connectors | 0,2 - 1,5 mm ² , 24 - 16 AWG | – |
| Torque setting with screw terminals | 0,5 Nm | – |
| Conductor cross section with spring-loaded terminals: Flexible with/without crimp connector | – | 0,2 - 1,5 mm ² , 24 - 16 AWG |

Safety relays PNOZ X PNOZ X2.9P

| Mechanical data | 777300 | 787300 |
|---|---------|---------|
| Spring-loaded terminals: Terminal points per connection | – | 2 |
| Stripping length with spring-loaded terminals | – | 8 mm |
| Dimensions | | |
| Height | 94 mm | 101 mm |
| Width | 22,5 mm | 22,5 mm |
| Depth | 121 mm | 121 mm |
| Weight | 180 g | 180 g |

Where standards are undated, the 2014-07 latest editions shall apply.

Safety characteristic data

| Operating Mode | EN ISO 13849-1: 2015 | EN ISO 13849-1: 2015 | EN 62061 SIL CL | EN 62061 PFH _D [1/h] | IEC 61511 SIL | IEC 61511 PFD | EN ISO 13849-1: 2015 T _M [year] |
|----------------|----------------------|----------------------|-----------------|---------------------------------|---------------|---------------|--|
| – | PL e | Cat. 4 | SIL CL 3 | 2,31E-09 | SIL 3 | 2,03E-06 | 20 |

All the units used within a safety function must be considered when calculating the safety characteristic data.

Supplementary data

The PFH value depends on the switching frequency and the load on the relay output. If the service life graphs are not accessible, the stated PFH value can be used irrespective of the switching frequency and the load, as the PFH value already considers the relay's B10d value as well as the failure rates of the other components.

Service life graph

The service life graphs indicate the number of cycles from which failures due to wear must be expected. The wear is mainly caused by the electrical load; the mechanical load is negligible.

Safety relays PNOZ X PNOZ X2.9P

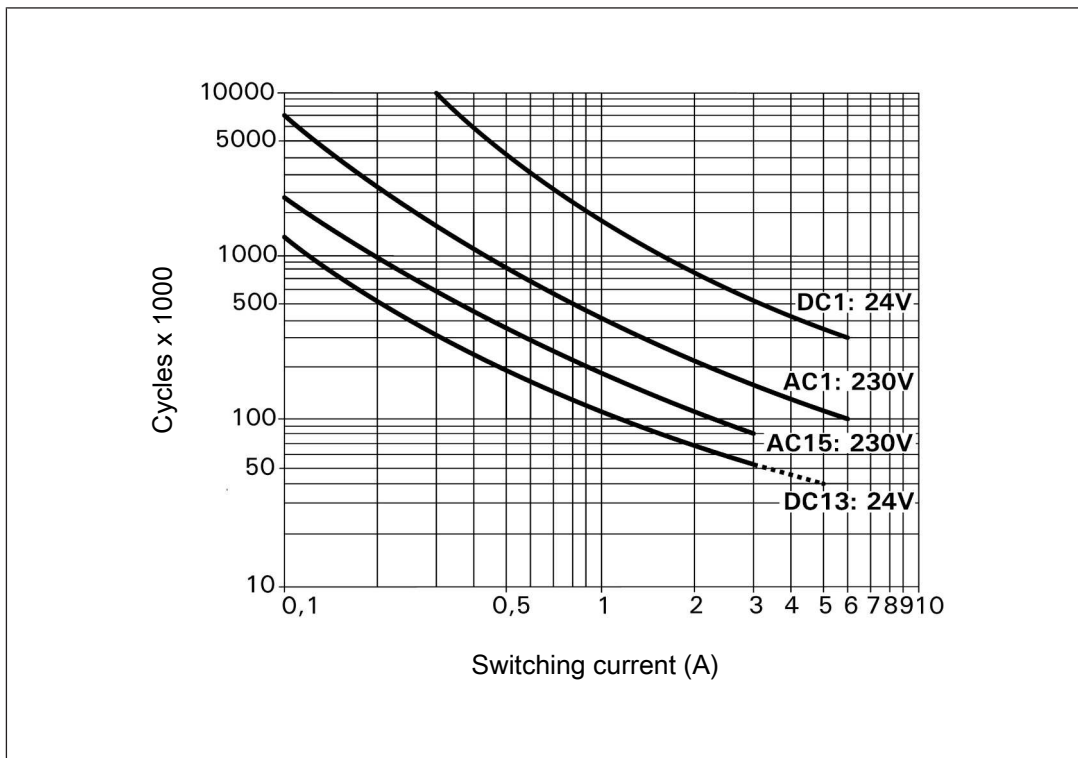

Fig.: Service life graphs at 24 VDC and 230 VAC

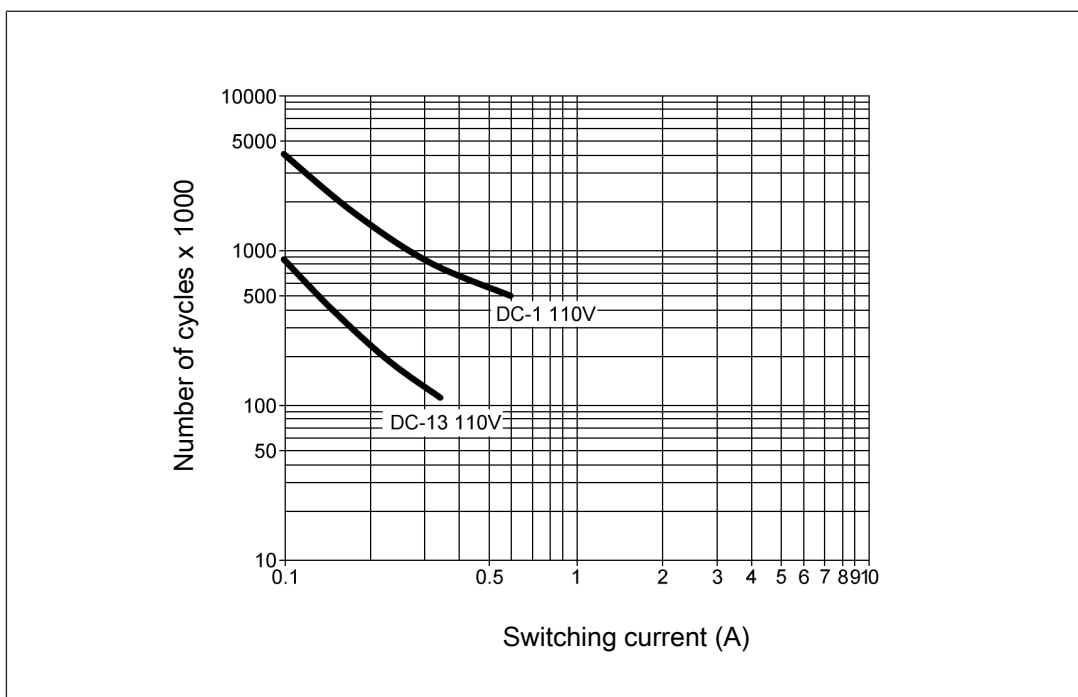

Fig.: Service life graphs at 110 VDC

Safety relays PNOZ X PNOZ X2.9P

Example

- ▶ Inductive load: 0.2 A
- ▶ Utilisation category: AC15
- ▶ Contact service life: 1 000 000 cycles

Provided the application to be implemented requires fewer than 1 000 000 cycles, the PFH value (see [Technical details \[📖 118\]](#)) can be used in the calculation.

To increase the service life, sufficient spark suppression must be provided on all relay contacts. With capacitive loads, any power surges that occur must be noted. With DC contactors, use flywheel diodes for spark suppression.

Order reference

| Product type | Features | Connection type | Order no. |
|--------------|----------|-------------------------|-----------|
| PNOZ X2.9P | 24 VDC | Screw terminals | 777 300 |
| PNOZ X2.9P C | 24 VDC | Spring-loaded terminals | 787 300 |

Safety relays PNOZ X PNOZ X3P

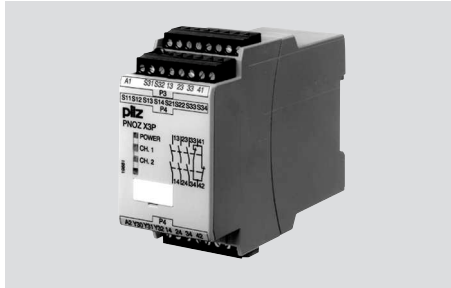

Unit features

- ▶ Positive-guided relay outputs:
 - 3 safety contacts (N/O), instantaneous
 - 1 auxiliary contact (N/C), instantaneous
- ▶ 1 semiconductor output
- ▶ Connection options for:
 - E-STOP pushbuttons
 - Safety gate limit switches
 - Start button
 - Light guards and safety switches
- ▶ LED display for:
 - Supply voltage
 - Switch status of the safety contacts
- ▶ Semiconductor output signals:
 - Switch state of the safety contacts
- ▶ Plug-in connection terminals (either spring-loaded terminal or screw terminal)
- ▶ See order reference for unit types

Safety relays PNOZ X PNOZ X3P

Block diagram/terminal configuration

Type: 24 VAC/DC

- ▶ U_B : 24 VAC/DC; Order no. 777310, 787310

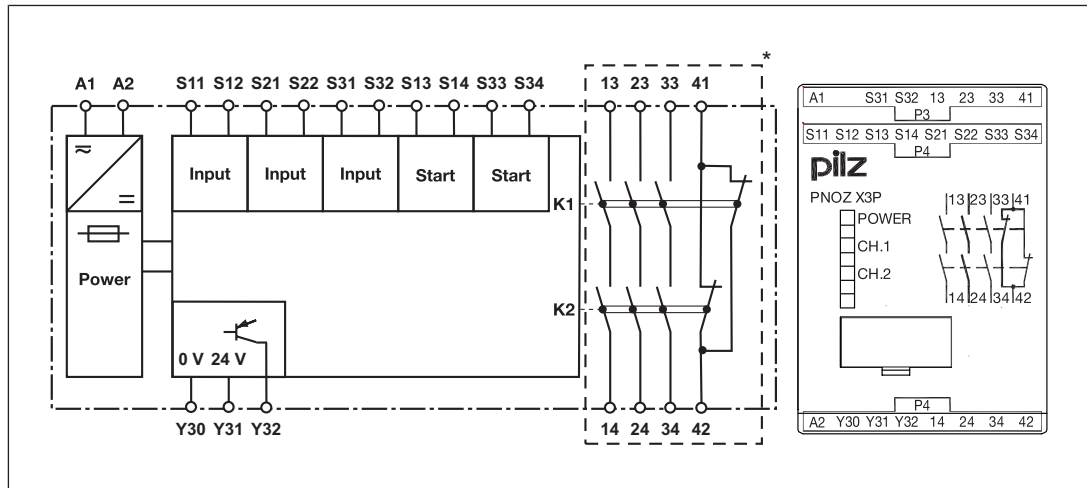

*Insulation between the non-marked area and the relay contacts: Basic insulation (over-voltage category III), Protective separation (overvoltage category II)

Type: 24-240 VAC/DC

- ▶ U_B : 24-240 VAC/DC; Order no. 777313, 787313

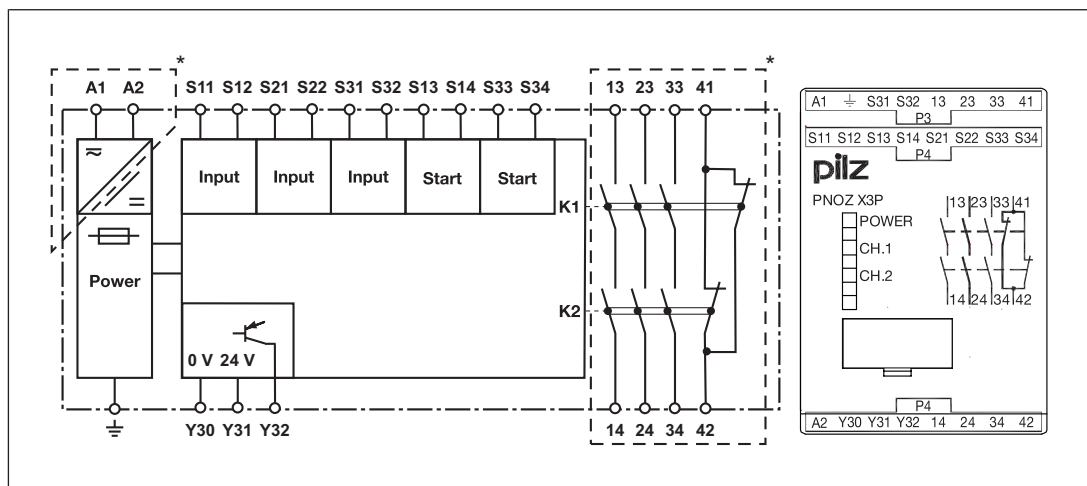

*Insulation between the non-marked area and the relay contacts: Basic insulation (over-voltage category III), Protective separation (overvoltage category II)

Safety relays PNOZ X PNOZ X3P

Function Description

The safety relay PNOZ X3P provides a safety-oriented interruption of a safety circuit. When supply voltage is supplied the "POWER" LED is lit. The unit is ready for operation when the start circuit S13-S14 is closed.

- ▶ Input circuit is closed (e.g. E-STOP pushbutton not operated):
 - Safety contacts 13-14, 23-24 and 33-34 are closed, auxiliary contact 41-42 is open. The unit is active.
 - The LEDs "CH.1" and "CH.2" are lit.
 - A high signal is present at the semiconductor output switch state Y32.
- ▶ Input circuit is opened (e.g. E-STOP pushbutton operated):
 - Safety contacts 13-14, 23-24 and 33-34 are opened redundantly, auxiliary contact 41-42 is closed.
 - The LEDs "CH.1" and "CH.2" go out.
 - A low signal is present at the semiconductor output switch state Y32.

Operating modes

- ▶ Single-channel operation: No redundancy in the input circuit, earth faults in the start and input circuit are detected.
- ▶ Dual-channel operation with detection of shorts across contacts: Redundant input circuit, PNOZ X3P detects
 - earth faults in the start and input circuit,
 - short circuits in the input circuit,
 - shorts across contacts in the input circuit.
- ▶ Automatic start: Unit is active once the input circuit has been closed.
- ▶ Monitored start: Unit is active once the input circuit is closed and once the start circuit is closed after the waiting period has elapsed (see [Technical details](#) [ 133]).
- ▶ Increase in the number of available contacts by connecting contact expander modules or external contactors/relays.

Safety relays PNOZ X PNOZ X3P

Timing diagram

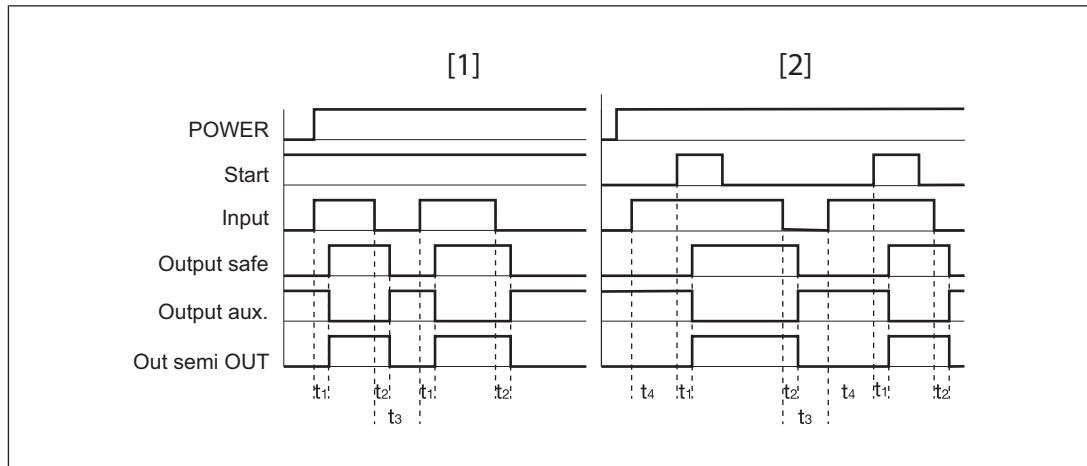

Legend

- ▶ Power: Supply voltage
- ▶ Start: Start circuit
- ▶ Input: Input circuit
- ▶ Output safe: Safety contacts
- ▶ Output aux.: Auxiliary contact
- ▶ Out semi OUT: Semiconductor output switch state
- ▶ [1]: Automatic start
- ▶ [2]: Monitored start
- ▶ t_1 : Switch-on delay
- ▶ t_2 : Delay-on de-energisation
- ▶ t_3 : Recovery time
- ▶ t_4 : Waiting period with a monitored start

Installation

- ▶ The unit should be installed in a control cabinet with a protection type of at least IP54.
- ▶ Use the notch on the rear of the unit to attach it to a DIN rail.
- ▶ Ensure the unit is mounted securely on a vertical DIN rail (35 mm) by using a fixing element (e.g. retaining bracket or an end angle).

Safety relays PNOZ X PNOZ X3P

Wiring

Please note:

- ▶ Information given in the "[Technical details \[133\]](#)" must be followed.
- ▶ Outputs 13-14, 23-24, 33-34 are safety contacts; output 41-42 is an auxiliary contact (e.g. for display).
- ▶ Auxiliary contact 41-42 should **not** be used for safety circuits!
- ▶ Do not connect undesignated terminals.
- ▶ Delivery status of units with screw terminals: Link between S11-S12 (dual-channel input circuit)
- ▶ To prevent contact welding, a fuse should be connected before the output contacts (see [Technical details \[133\]](#)).
- ▶ Calculation of the max. cable length l_{\max} in the input circuit:

$$l_{\max} = \frac{R_{l_{\max}}}{R_l / \text{km}}$$

$R_{l_{\max}}$ = max. overall cable resistance (see [Technical details \[133\]](#))

R_l / km = cable resistance/km

- ▶ Use copper wire that can withstand 60/75 °C.
- ▶ Do not switch low currents using contacts that have been used previously with high currents.
- ▶ Sufficient fuse protection must be provided on all output contacts with capacitive and inductive loads.
- ▶ When connecting magnetically operated, reed proximity switches, ensure that the max. peak inrush current (on the input circuit) does not overload the proximity switch.
- ▶ On 24 VAC/DC units:
The power supply must comply with the regulations for extra low voltages with safe electrical separation (SELV, PELV) in accordance with VDE 0100, Part 410.
- ▶ Ensure the wiring and EMC requirements of IEC 60204-1 are met.

Important for detection of shorts across contacts:

As this function for detecting shorts across contacts is not failsafe, it is tested by Pilz during the final control check. If there is a danger of exceeding the cable length, we recommend the following test once the unit is installed:

1. Unit ready for operation (output contacts closed)
2. Short circuit the test terminals S22, S32 for detecting shorts across the inputs.
3. The unit's fuse must be triggered and the output contacts must open. Cable lengths in the scale of the maximum length can delay the fuse triggering for up to 2 minutes.
4. Reset the fuse: Remove the short circuit and switch off the supply voltage for approx. 1 minute.

Safety relays PNOZ X PNOZ X3P

Preparing for operation

| Supply voltage | 24 VAC/DC | 24 - 240 V AC/DC |
|---|----------------|------------------|
| | | |
| Input circuit | Single-channel | Dual-channel |
| E-STOP without detection of shorts across contacts | | |
| E-STOP with detection of shorts across contacts | | |
| Safety gate without detection of shorts across contacts | | |
| Safety gate with detection of shorts across contacts | | |
| Light guard or safety switch, detection of shorts across contacts via ESPE (only for units with $U_B = 24$ VDC) | | |

Safety relays PNOZ X PNOZ X3P

| | E-STOP wiring | |
|-----------------------------------|--|---------------------------------------|
| Start circuit | Safety gate without start-up test | Safety gate with start-up test |
| Automatic start | | |
| Monitored start | | |
| Feedback loop | Automatic start | Monitored start |
| Contacts from external contactors | | |
| Semiconductor output | | |
| | | |

Legend

- ▶ S1/S2: E-STOP/safety gate switch
- ▶ S3: Reset button
- ▶ ↑↑: Switch operated
- ▶ : Gate open
- ▶ : Gate closed

Safety relays PNOZ X PNOZ X3P

Dimensions in mm

* With spring-loaded terminals

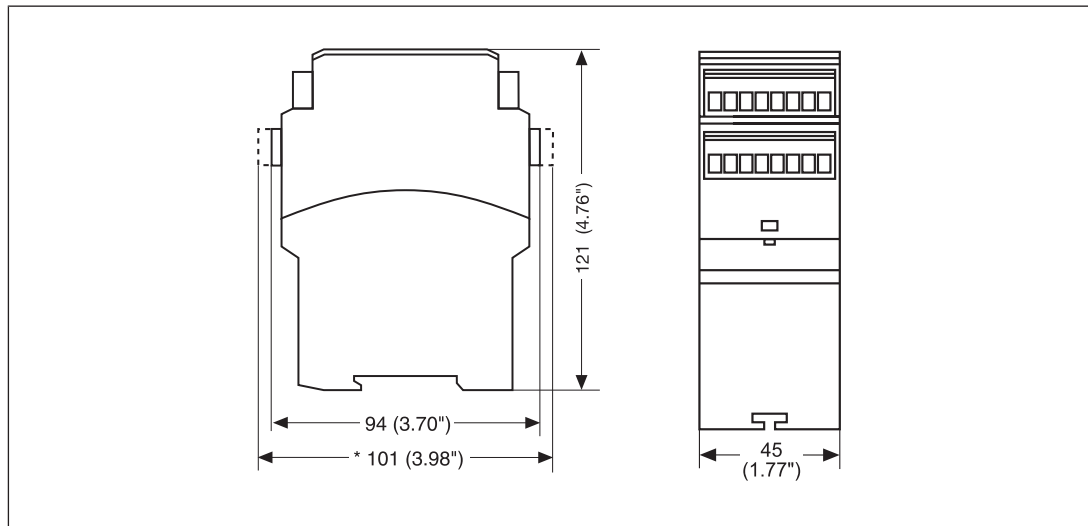

Technical details

Order no. 777310 – 777313

See below for more order numbers

| General | 777310 | 777313 |
|--------------------------------------|--|--|
| Approvals | CCC, CE, EAC (Eurasian), KOSHA, TÜV, cULus Listed | CCC, CE, EAC (Eurasian), KOSHA, TÜV, cULus Listed |
| Electrical data | 777310 | 777313 |
| Supply voltage | | |
| Voltage | 24 V | 24 - 240 V |
| Kind | AC/DC | AC/DC |
| Voltage tolerance | -15 %/+10 % | -15 %/+10 % |
| Output of external power supply (AC) | 5 VA | 5 VA |
| Output of external power supply (DC) | 2,5 W | 2,5 W |
| Frequency range AC | 50 - 60 Hz | 50 - 60 Hz |
| Residual ripple DC | 160 % | 160 % |
| Duty cycle | 100 % | 100 % |
| Max. inrush current impulse | | |
| Current pulse, A1 | 1,7 A | – |
| Pulse duration, A1 | 1,5 ms | – |
| Inputs | 777310 | 777313 |
| Number | 2 | 2 |

Safety relays PNOZ X PNOZ X3P

| Inputs | 777310 | 777313 |
|---|---------------|---------------|
| Voltage at | | |
| Input circuit DC | 24 V | 24 V |
| Start circuit DC | 24 V | 24 V |
| Feedback loop DC | 24 V | 24 V |
| Current at | | |
| Input circuit DC | 40 mA | 35 mA |
| Start circuit DC | 70 mA | 50 mA |
| Feedback loop DC | 20 mA | 20 mA |
| Min. input resistance at power-on | 90 Ohm | 90 Ohm |
| Max. overall cable resistance RI-max | | |
| Single-channel at UB DC | 150 Ohm | 200 Ohm |
| Single-channel at UB AC | 180 Ohm | 200 Ohm |
| Dual-channel without detection of shorts across contacts at UB DC | 300 Ohm | 400 Ohm |
| Dual-channel without detection of shorts across contacts at UB AC | 360 Ohm | 400 Ohm |
| Dual-channel with detection of shorts across contacts at UB DC | 15 Ohm | 30 Ohm |
| Dual-channel with detection of shorts across contacts at UB AC | 30 Ohm | 30 Ohm |
| Semiconductor outputs | 777310 | 777313 |
| Number | 1 | 1 |
| Voltage | 24 V | 24 V |
| Current | 20 mA | 20 mA |
| External supply voltage | 24 V | 24 V |
| Voltage tolerance | -20 %/+20 % | -20 %/+20 % |
| Relay outputs | 777310 | 777313 |
| Number of output contacts | | |
| Safety contacts (N/O), instantaneous | 3 | 3 |
| Auxiliary contacts (N/C) | 1 | 1 |
| Max. short circuit current IK | 1 kA | 1 kA |
| Utilisation category | | |
| In accordance with the standard | EN 60947-4-1 | EN 60947-4-1 |

Safety relays PNOZ X PNOZ X3P

| Relay outputs | 777310 | 777313 |
|--|-------------------|-------------------|
| Utilisation category of safety contacts | | |
| AC1 at | 240 V | 240 V |
| Min. current | 0,01 A | 0,01 A |
| Max. current | 8 A | 8 A |
| Max. power | 2000 VA | 2000 VA |
| DC1 at | 24 V | 24 V |
| Min. current | 0,01 A | 0,01 A |
| Max. current | 8 A | 8 A |
| Max. power | 200 W | 200 W |
| Utilisation category of auxiliary contacts | | |
| AC1 at | 240 V | 240 V |
| Min. current | 0,01 A | 0,01 A |
| Max. current | 8 A | 8 A |
| Max. power | 2000 VA | 2000 VA |
| DC1 at | 24 V | 24 V |
| Min. current | 0,01 A | 0,01 A |
| Max. current | 8 A | 8 A |
| Max. power | 200 W | 200 W |
| Utilisation category | | |
| In accordance with the standard | EN 60947-5-1 | EN 60947-5-1 |
| Utilisation category of safety contacts | | |
| AC15 at | 230 V | 230 V |
| Max. current | 5 A | 5 A |
| DC13 (6 cycles/min) at | 24 V | 24 V |
| Max. current | 6 A | 6 A |
| Utilisation category of auxiliary contacts | | |
| AC15 at | 230 V | 230 V |
| Max. current | 5 A | 5 A |
| DC13 (6 cycles/min) at | 24 V | 24 V |
| Max. current | 6 A | 6 A |
| Utilisation category in accordance with UL | | |
| Voltage | 240 V AC G. P. | 240 V AC G. P. |
| With current | 8 A | 8 A |
| Voltage | 24 V DC Resistive | 24 V DC Resistive |
| With current | 5 A | 5 A |
| Pilot Duty | B300, R300 | B300, R300 |

Safety relays PNOZ X PNOZ X3P

| Relay outputs | 777310 | 777313 |
|--|--------------------------------------|--------------------------------------|
| External contact fuse protection, safety contacts | | |
| In accordance with the standard | EN 60947-5-1 | EN 60947-5-1 |
| Max. melting integral | 240 A²s | 240 A²s |
| Blow-out fuse, quick | 10 A | 10 A |
| Blow-out fuse, slow | 6 A | 6 A |
| Blow-out fuse, gG | 10 A | 10 A |
| Circuit breaker 24V AC/DC, characteristic B/C | 6 A | 6 A |
| External contact fuse protection, auxiliary contacts | | |
| Max. melting integral | 240 A²s | 240 A²s |
| Blow-out fuse, quick | 10 A | 10 A |
| Blow-out fuse, slow | 6 A | 6 A |
| Blow-out fuse, gG | 10 A | 10 A |
| Circuit breaker 24 V AC/DC, characteristic B/C | 6 A | 6 A |
| Contact material | AgSnO₂ + 0,2 µm Au | AgSnO₂ + 0,2 µm Au |
| Conventional thermal current while loading several contacts | 777310 | 777313 |
| I _{th} per contact at UB AC; AC1: 240 V, DC1: 24 V | | |
| Conv. therm. current with 1 contact | 8 A | 8 A |
| Conv. therm. current with 2 contacts | 7 A | 7 A |
| Conv. therm. current with 3 contacts | 6 A | 6 A |
| I _{th} per contact at UB DC; AC1: 240 V, DC1: 24 V | | |
| Conv. therm. current with 1 contact | 8 A | 8 A |
| Conv. therm. current with 2 contacts | 8 A | 7 A |
| Conv. therm. current with 3 contacts | 7 A | 6 A |

Safety relays PNOZ X PNOZ X3P

| Times | 777310 | 777313 |
|--|--|--|
| Switch-on delay | | |
| With automatic start typ. | 250 ms | 330 ms |
| With automatic start max. | 500 ms | 450 ms |
| With automatic start after power on typ. | 280 ms | 750 ms |
| With automatic start after power on max. | 550 ms | 1.000 ms |
| With monitored start typ. | 35 ms | 35 ms |
| With monitored start max. | 50 ms | 50 ms |
| Delay-on de-energisation | | |
| With E-STOP typ. | 15 ms | 25 ms |
| With E-STOP max. | 30 ms | 30 ms |
| With power failure typ. | 50 ms | – |
| With power failure max. | 70 ms | – |
| With power failure typ. UB 240 V – | – | 1500 ms |
| With power failure max. UB 240 V | – | 2200 ms |
| With power failure typ. UB 24 V – | – | 150 ms |
| With power failure max. UB 24 V – | – | 180 ms |
| Recovery time at max. switching frequency 1/s | | |
| After E-STOP | 50 ms | 50 ms |
| After power failure | 100 ms | 200 ms |
| After power failure on wide-range power supply | – | 2250 ms |
| Waiting period with a monitored start | 300 ms | 200 ms |
| Min. start pulse duration with a monitored start | 30 ms | 30 ms |
| Supply interruption before de-energisation | 20 ms | 20 ms |
| Simultaneity, channel 1 and 2 max. | ∞ | ∞ |
| Environmental data | | |
| Climatic suitability | EN 60068-2-78 | EN 60068-2-78 |
| Ambient temperature | | |
| Temperature range | -20 - 55 °C | -20 - 55 °C |
| Storage temperature | | |
| Temperature range | -40 - 85 °C | -40 - 85 °C |
| Climatic suitability | | |
| Humidity | 93 % r. h. at 40 °C | 93 % r. h. at 40 °C |
| Condensation during operation | Not permitted | Not permitted |
| EMC | EN 60947-5-1, EN 61000-6-2, EN 61326-3-1 | EN 60947-5-1, EN 61000-6-2, EN 61000-6-3, EN 61326-3-1 |

Safety relays PNOZ X PNOZ X3P

| Environmental data | 777310 | 777313 |
|---|---|---|
| Vibration | | |
| In accordance with the standard | EN 60068-2-6 | EN 60068-2-6 |
| Frequency | 10 - 55 Hz | 10 - 55 Hz |
| Amplitude | 0,35 mm | 0,35 mm |
| Airgap creepage | | |
| In accordance with the standard | EN 60947-1 | EN 60947-1 |
| Overvoltage category | III / II | III / II |
| Pollution degree | 2 | 2 |
| Rated insulation voltage | 250 V | 250 V |
| Rated impulse withstand voltage | 4 kV | 4 kV |
| Protection type | | |
| Mounting area (e.g. control cabinet) | IP54 | IP54 |
| Housing | IP40 | IP40 |
| Terminals | IP20 | IP20 |
| Mechanical data | 777310 | 777313 |
| Mounting position | Any | Any |
| Mechanical life | 10,000,000 cycles | 10,000,000 cycles |
| Material | | |
| Bottom | PPO UL 94 V0 | PPO UL 94 V0 |
| Front | ABS UL 94 V0 | ABS UL 94 V0 |
| Top | PPO UL 94 V0 | PPO UL 94 V0 |
| Connection type | Screw terminal | Screw terminal |
| Mounting type | plug-in | plug-in |
| Conductor cross section with screw terminals | | |
| 1 core flexible | 0,25 - 2,5 mm², 24 - 12 AWG | 0,25 - 2,5 mm², 24 - 12 AWG |
| 2 core with the same cross section, flexible with crimp connectors, no plastic sleeve | 0,25 - 1 mm², 24 - 16 AWG | 0,25 - 1 mm², 24 - 16 AWG |
| 2 core with the same cross section, flexible without crimp connectors or with TWIN crimp connectors | 0,2 - 1,5 mm², 24 - 16 AWG | 0,2 - 1,5 mm², 24 - 16 AWG |
| Torque setting with screw terminals | 0,5 Nm | 0,5 Nm |
| Dimensions | | |
| Height | 94 mm | 94 mm |
| Width | 45 mm | 45 mm |
| Depth | 121 mm | 121 mm |
| Weight | 270 g | 310 g |

Where standards are undated, the 2014-07 latest editions shall apply.

Safety relays PNOZ X PNOZ X3P

Order no. 787310 – 787313

| General | 787310 | 787313 |
|--------------------------------------|--|--|
| Approvals | CCC, CE, EAC (Eurasian), KOSHA, TÜV, cULus Listed | CCC, CE, EAC (Eurasian), KOSHA, TÜV, cULus Listed |
| Electrical data | 787310 | 787313 |
| Supply voltage | | |
| Voltage | 24 V | 24 - 240 V |
| Kind | AC/DC | AC/DC |
| Voltage tolerance | -15 %/+10 % | -15 %/+10 % |
| Output of external power supply (AC) | 5 VA | 5 VA |
| Output of external power supply (DC) | 2,5 W | 2,5 W |
| Frequency range AC | 50 - 60 Hz | 50 - 60 Hz |
| Residual ripple DC | 160 % | 160 % |
| Duty cycle | 100 % | 100 % |
| Max. inrush current impulse | | |
| Current pulse, A1 | 1,7 A | – |
| Pulse duration, A1 | 1,5 ms | – |
| Inputs | 787310 | 787313 |
| Number | 2 | 2 |
| Voltage at | | |
| Input circuit DC | 24 V | 24 V |
| Start circuit DC | 24 V | 24 V |
| Feedback loop DC | 24 V | 24 V |
| Current at | | |
| Input circuit DC | 40 mA | 35 mA |
| Start circuit DC | 70 mA | 50 mA |
| Feedback loop DC | 20 mA | 20 mA |
| Min. input resistance at power-on | 90 Ohm | 90 Ohm |

Safety relays PNOZ X PNOZ X3P

| Inputs | 787310 | 787313 |
|---|--------------|--------------|
| Max. overall cable resistance RI-max | | |
| Single-channel at UB DC | 150 Ohm | 200 Ohm |
| Single-channel at UB AC | 180 Ohm | 200 Ohm |
| Dual-channel without detection of shorts across contacts at UB DC | 300 Ohm | 400 Ohm |
| Dual-channel without detection of shorts across contacts at UB AC | 360 Ohm | 400 Ohm |
| Dual-channel with detection of shorts across contacts at UB DC | 15 Ohm | 30 Ohm |
| Dual-channel with detection of shorts across contacts at UB AC | 30 Ohm | 30 Ohm |
| Semiconductor outputs | 787310 | 787313 |
| Number | 1 | 1 |
| Voltage | 24 V | 24 V |
| Current | 20 mA | 20 mA |
| External supply voltage | 24 V | 24 V |
| Voltage tolerance | -20 %/+20 % | -20 %/+20 % |
| Relay outputs | 787310 | 787313 |
| Number of output contacts | | |
| Safety contacts (N/O), instantaneous | 3 | 3 |
| Auxiliary contacts (N/C) | 1 | 1 |
| Max. short circuit current IK | 1 kA | 1 kA |
| Utilisation category | | |
| In accordance with the standard | EN 60947-4-1 | EN 60947-4-1 |
| Utilisation category of safety contacts | | |
| AC1 at | 240 V | 240 V |
| Min. current | 0,01 A | 0,01 A |
| Max. current | 8 A | 8 A |
| Max. power | 2000 VA | 2000 VA |
| DC1 at | 24 V | 24 V |
| Min. current | 0,01 A | 0,01 A |
| Max. current | 8 A | 8 A |
| Max. power | 200 W | 200 W |

Safety relays PNOZ X PNOZ X3P

| Relay outputs | 787310 | 787313 |
|---|---------------------------|---------------------------|
| Utilisation category of auxiliary contacts | | |
| AC1 at | 240 V | 240 V |
| Min. current | 0,01 A | 0,01 A |
| Max. current | 8 A | 8 A |
| Max. power | 2000 VA | 2000 VA |
| DC1 at | 24 V | 24 V |
| Min. current | 0,01 A | 0,01 A |
| Max. current | 8 A | 8 A |
| Max. power | 200 W | 200 W |
| Utilisation category | | |
| In accordance with the standard | EN 60947-5-1 | EN 60947-5-1 |
| Utilisation category of safety contacts | | |
| AC15 at | 230 V | 230 V |
| Max. current | 5 A | 5 A |
| DC13 (6 cycles/min) at | 24 V | 24 V |
| Max. current | 6 A | 6 A |
| Utilisation category of auxiliary contacts | | |
| AC15 at | 230 V | 230 V |
| Max. current | 5 A | 5 A |
| DC13 (6 cycles/min) at | 24 V | 24 V |
| Max. current | 6 A | 6 A |
| Utilisation category in accordance with UL | | |
| Voltage | 240 V AC G. P. | 240 V AC G. P. |
| With current | 8 A | 8 A |
| Voltage | 24 V DC Resistive | 24 V DC Resistive |
| With current | 5 A | 5 A |
| Pilot Duty | B300, R300 | B300, R300 |
| External contact fuse protection, safety contacts | | |
| In accordance with the standard | EN 60947-5-1 | EN 60947-5-1 |
| Max. melting integral | 240 A²s | 240 A²s |
| Blow-out fuse, quick | 10 A | 10 A |
| Blow-out fuse, slow | 6 A | 6 A |
| Blow-out fuse, gG | 10 A | 10 A |
| Circuit breaker 24V AC/DC, characteristic B/C | 6 A | 6 A |

Safety relays PNOZ X PNOZ X3P

| Relay outputs | 787310 | 787313 |
|--|--------------------------------|--------------------------------|
| External contact fuse protection, auxiliary contacts | | |
| Max. melting integral | 240 A ² s | 240 A ² s |
| Blow-out fuse, quick | 10 A | 10 A |
| Blow-out fuse, slow | 6 A | 6 A |
| Blow-out fuse, gG | 10 A | 10 A |
| Circuit breaker 24 V AC/DC, characteristic B/C | 6 A | 6 A |
| Contact material | AgSnO ₂ + 0,2 µm Au | AgSnO ₂ + 0,2 µm Au |
| Conventional thermal current while loading several contacts | 787310 | 787313 |
| I _{th} per contact at UB AC; AC1: 240 V, DC1: 24 V | | |
| Conv. therm. current with 1 contact | 8 A | 8 A |
| Conv. therm. current with 2 contacts | 7 A | 7 A |
| Conv. therm. current with 3 contacts | 6 A | 6 A |
| I _{th} per contact at UB DC; AC1: 240 V, DC1: 24 V | | |
| Conv. therm. current with 1 contact | 8 A | 8 A |
| Conv. therm. current with 2 contacts | 8 A | 7 A |
| Conv. therm. current with 3 contacts | 7 A | 6 A |
| Times | 787310 | 787313 |
| Switch-on delay | | |
| With automatic start typ. | 250 ms | 330 ms |
| With automatic start max. | 500 ms | 450 ms |
| With automatic start after power on typ. | 280 ms | 750 ms |
| With automatic start after power on max. | 550 ms | 1.000 ms |
| With monitored start typ. | 35 ms | 35 ms |
| With monitored start max. | 50 ms | 50 ms |

Safety relays PNOZ X PNOZ X3P

| Times | 787310 | 787313 |
|--|--|--|
| Delay-on de-energisation | | |
| With E-STOP typ. | 15 ms | 25 ms |
| With E-STOP max. | 30 ms | 30 ms |
| With power failure typ. | 50 ms | – |
| With power failure max. | 70 ms | – |
| With power failure typ. UB 240 V – | | 1500 ms |
| With power failure max. UB 240 V | – | 2200 ms |
| With power failure typ. UB 24 V – | | 150 ms |
| With power failure max. UB 24 V – | | 180 ms |
| Recovery time at max. switching frequency 1/s | | |
| After E-STOP | 50 ms | 50 ms |
| After power failure | 100 ms | 200 ms |
| After power failure on wide-range power supply | – | 2250 ms |
| Waiting period with a monitored start | | |
| | 300 ms | 200 ms |
| Min. start pulse duration with a monitored start | | |
| | 30 ms | 30 ms |
| Supply interruption before de-energisation | | |
| | 20 ms | 20 ms |
| Simultaneity, channel 1 and 2 max. | | |
| | ∞ | ∞ |
| Environmental data | 787310 | 787313 |
| Climatic suitability | | |
| | EN 60068-2-78 | EN 60068-2-78 |
| Ambient temperature | | |
| Temperature range | -20 - 55 °C | -20 - 55 °C |
| Storage temperature | | |
| Temperature range | -40 - 85 °C | -40 - 85 °C |
| Climatic suitability | | |
| Humidity | 93 % r. h. at 40 °C | 93 % r. h. at 40 °C |
| Condensation during operation | | |
| | Not permitted | Not permitted |
| EMC | | |
| | EN 60947-5-1, EN 61000-6-2, EN 61326-3-1 | EN 60947-5-1, EN 61000-6-2, EN 61000-6-3, EN 61326-3-1 |
| Vibration | | |
| In accordance with the standard | EN 60068-2-6 | EN 60068-2-6 |
| Frequency | 10 - 55 Hz | 10 - 55 Hz |
| Amplitude | 0,35 mm | 0,35 mm |
| Airgap creepage | | |
| In accordance with the standard | EN 60947-1 | EN 60947-1 |
| Overvoltage category | III / II | III / II |
| Pollution degree | 2 | 2 |

Safety relays PNOZ X PNOZ X3P

| | | |
|---|--|--|
| Environmental data | 787310 | 787313 |
| Rated insulation voltage | 250 V | 250 V |
| Rated impulse withstand voltage | 4 kV | 4 kV |
| Protection type | | |
| Mounting area (e.g. control cabinet) | IP54 | IP54 |
| Housing | IP40 | IP40 |
| Terminals | IP20 | IP20 |
| Mechanical data | 787310 | 787313 |
| Mounting position | Any | Any |
| Mechanical life | 10,000,000 cycles | 10,000,000 cycles |
| Material | | |
| Bottom | PPO UL 94 V0 | PPO UL 94 V0 |
| Front | ABS UL 94 V0 | ABS UL 94 V0 |
| Top | PPO UL 94 V0 | PPO UL 94 V0 |
| Connection type | Spring-loaded terminal | Spring-loaded terminal |
| Mounting type | plug-in | plug-in |
| Conductor cross section with spring-loaded terminals: Flexible with/without crimp connector | 0,2 - 1,5 mm², 24 - 16 AWG | 0,2 - 1,5 mm², 24 - 16 AWG |
| Spring-loaded terminals: Terminal points per connection | 2 | 2 |
| Stripping length with spring-loaded terminals | 8 mm | 8 mm |
| Dimensions | | |
| Height | 101 mm | 101 mm |
| Width | 45 mm | 45 mm |
| Depth | 121 mm | 121 mm |
| Weight | 270 g | 310 g |

Where standards are undated, the 2014-07 latest editions shall apply.

Safety characteristic data

| Operating Mode | EN ISO 13849-1: 2015 | EN ISO 13849-1: 2015 | EN 62061 SIL CL | EN 62061 PFH _D [1/h] | IEC 61511 SIL | IEC 61511 PFD | EN ISO 13849-1: 2015 T _M [year] |
|----------------|----------------------|----------------------|-----------------|---------------------------------|---------------|-----------------|--|
| – | PL e | Cat. 4 | SIL CL 3 | 2,31E-09 | SIL 3 | 2,03E-06 | 20 |

All the units used within a safety function must be considered when calculating the safety characteristic data.

Safety relays PNOZ X PNOZ X3P

Supplementary data

The PFH value depends on the switching frequency and the load on the relay output. If the service life graphs are not accessible, the stated PFH value can be used irrespective of the switching frequency and the load, as the PFH value already considers the relay's B10d value as well as the failure rates of the other components.

Service life graph

The service life graphs indicate the number of cycles from which failures due to wear must be expected. The wear is mainly caused by the electrical load; the mechanical load is negligible.

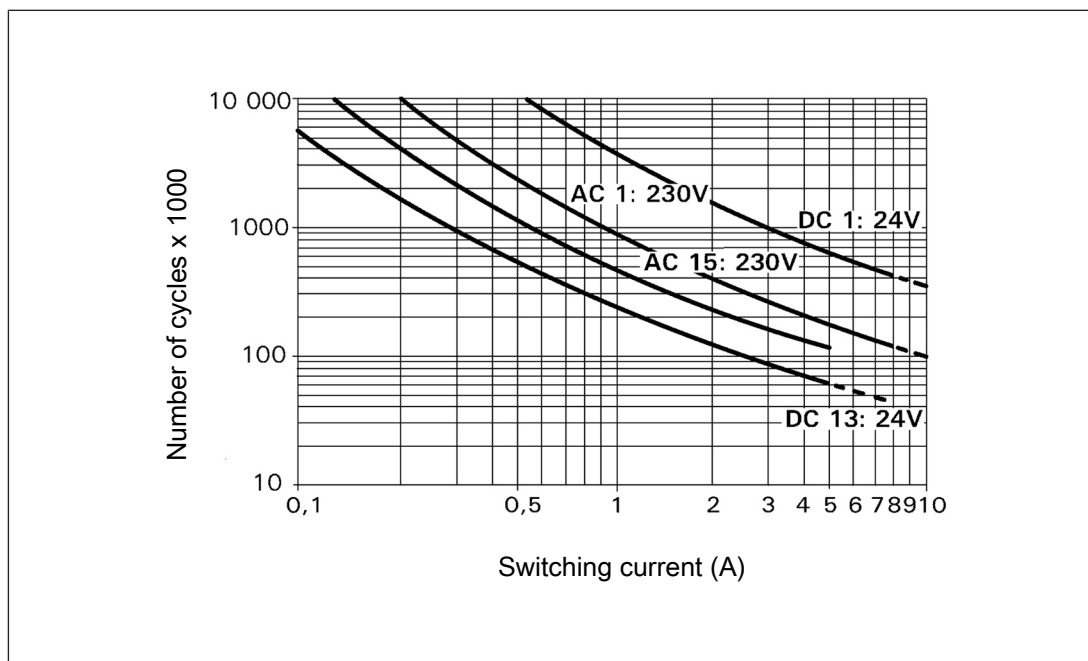

Example

- ▶ Inductive load: 0.2 A
- ▶ Utilisation category: AC15
- ▶ Contact service life: 4 000 000 cycles

Provided the application to be implemented requires fewer than 4 000 000 cycles, the PFH value (see Technical details) can be used in the calculation.

To increase the service life, sufficient spark suppression must be provided on all output contacts. With capacitive loads, any power surges that occur must be noted. With DC contactors, use flywheel diodes for spark suppression.

Safety relays PNOZ X PNOZ X3P

Order reference

| Product type | Features | Connection type | Order no. |
|--------------|------------------|-------------------------|-----------|
| PNOZ X3P | 24 VAC/DC | Screw terminals | 777 310 |
| PNOZ X3P C | 24 VAC/DC | Spring-loaded terminals | 787 310 |
| PNOZ X3P | 24 - 240 V AC/DC | Screw terminals | 777 313 |
| PNOZ X3P C | 24 - 240 V AC/DC | Spring-loaded terminals | 787 313 |

Safety relays PNOZ X PNOZ X3.10P

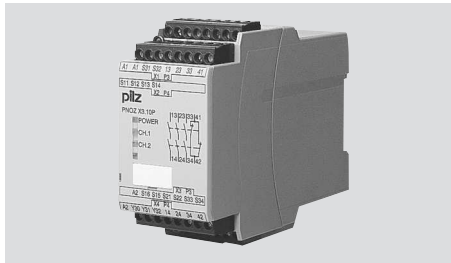

Unit features

- ▶ Positive-guided relay outputs:
 - 3 safety contacts (N/O), instantaneous
 - 1 auxiliary contact (N/C), instantaneous
- ▶ 1 semiconductor output
- ▶ Connection options for:
 - E-STOP pushbuttons
 - Safety gate limit switches
 - Start button
 - Light guards and safety switches
- ▶ LED display for:
 - Supply voltage
 - Switch status of the safety contacts
- ▶ Semiconductor output signals:
 - Switch state of the safety contacts
- ▶ Plug-in connection terminals (either spring-loaded terminal or screw terminal)
- ▶ See order reference for unit types

Safety relays PNOZ X PNOZ X3.10P

Block diagram/terminal configuration

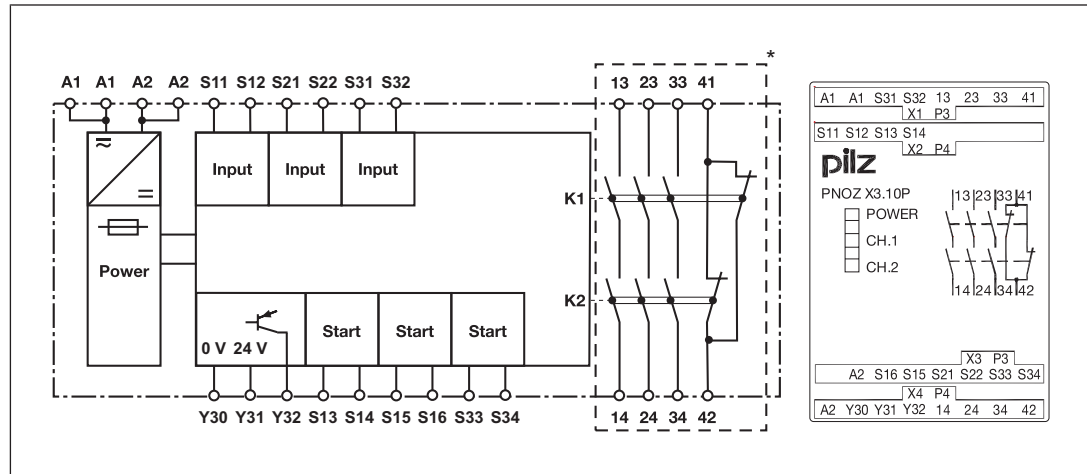

*Insulation between the non-marked area and the relay contacts: Basic insulation (over-voltage category III), Protective separation (overvoltage category II)

Function Description

The safety relay PNOZ X3.10P provides a safety-oriented interruption of a safety circuit. When supply voltage is supplied the "POWER" LED is lit. The unit is ready for operation when the start circuit S13-S14 is closed.

- ▶ Input circuit is closed (e.g. E-STOP pushbutton not operated):
 - Safety contacts 13-14, 23-24 and 33-34 are closed, auxiliary contact 41-42 is open. The unit is active.
 - The LEDs "CH.1" and "CH.2" are lit.
 - A high signal is present at the semiconductor output switch state Y32.
- ▶ Input circuit is opened (e.g. E-STOP pushbutton operated):
 - Safety contacts 13-14, 23-24 and 33-34 are opened redundantly, auxiliary contact 41-42 is closed.
 - The LEDs "CH.1" and "CH.2" go out.
 - A low signal is present at the semiconductor output switch state Y32.

Operating modes

- ▶ Single-channel operation: No redundancy in the input circuit, earth faults in the start and input circuit are detected.
- ▶ Dual-channel operation with detection of shorts across contacts: Redundant input circuit, PNOZ X3.10P detects
 - earth faults in the start and input circuit,
 - short circuits in the input circuit,

Safety relays PNOZ X PNOZ X3.10P

- shorts across contacts in the input circuit.
- ▶ Automatic start: Unit is active once the input circuit has been closed.
- ▶ Manual start: Unit is active once the input circuit and the start circuit are closed.
- ▶ Monitored start: Unit is active once the input circuit is closed and once the start circuit is closed after the waiting period has elapsed (see [Technical details \[154\]](#)).
- ▶ Increase in the number of available contacts by connecting contact expander modules or external contactors/relays.

Timing diagram

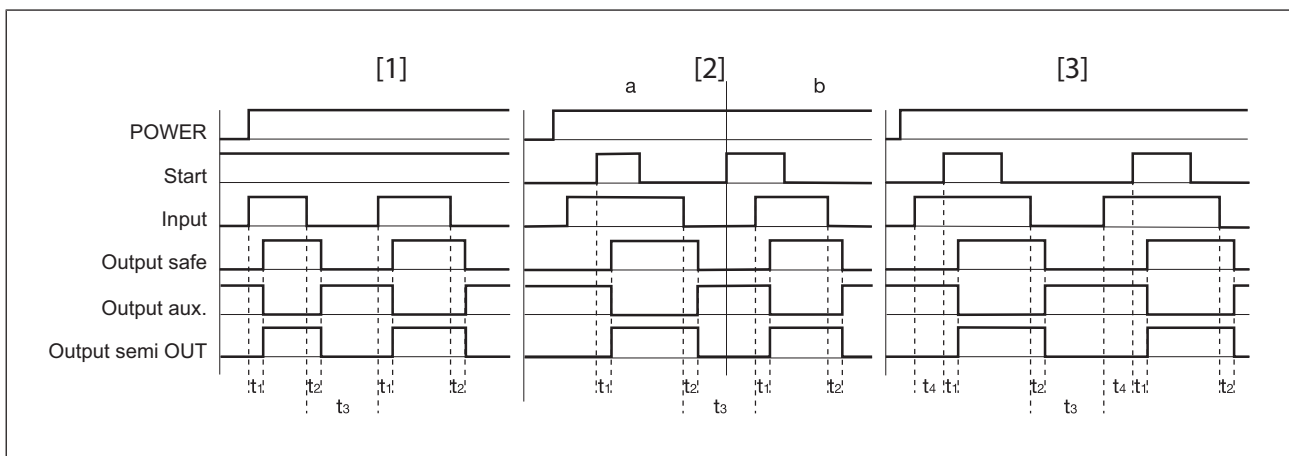

Legend

- ▶ Power: Supply voltage
- ▶ Start: Start circuit
- ▶ Input: Input circuit
- ▶ Output safe: Safety contacts
- ▶ Output aux.: Auxiliary contact
- ▶ Out semi OUT: Semiconductor output switch state
- ▶ [1]: Automatic start
- ▶ [2]: Manual start
- ▶ [3]: Monitored start
- ▶ a: Input circuit closes before start circuit
- ▶ b: Start circuit closes before input circuit
- ▶ t_1 : Switch-on delay
- ▶ t_2 : Delay-on de-energisation
- ▶ t_3 : Recovery time
- ▶ t_4 : Waiting period with a monitored start

Safety relays PNOZ X PNOZ X3.10P

Installation

- ▶ The unit should be installed in a control cabinet with a protection type of at least IP54.
- ▶ Use the notch on the rear of the unit to attach it to a DIN rail.
- ▶ Ensure the unit is mounted securely on a vertical DIN rail (35 mm) by using a fixing element (e.g. retaining bracket or an end angle).

Wiring

Please note:

- ▶ Information given in the "[Technical details \[154\]](#)" must be followed.
- ▶ Outputs 13-14, 23-24, 33-34 are safety contacts; output 41-42 is an auxiliary contact (e.g. for display).
- ▶ Auxiliary contact 41-42 should **not** be used for safety circuits!
- ▶ Do not connect undesignated terminals.
- ▶ Delivery status of units with screw terminals: Link between S11-S12 (dual-channel input circuit) and link between S15-S16 (safety gate with start-up test)
- ▶ To prevent contact welding, a fuse should be connected before the output contacts (see [Technical details \[154\]](#)).
- ▶ Calculation of the max. cable length l_{\max} in the input circuit:

$$l_{\max} = \frac{R_{l_{\max}}}{R_l / \text{km}}$$

$R_{l_{\max}}$ = max. overall cable resistance (see [Technical details \[154\]](#))

R_l / km = cable resistance/km

- ▶ Use copper wire that can withstand 60/75 °C.
- ▶ Do not switch low currents using contacts that have been used previously with high currents.
- ▶ Sufficient fuse protection must be provided on all output contacts with capacitive and inductive loads.
- ▶ When connecting magnetically operated, reed proximity switches, ensure that the max. peak inrush current (on the input circuit) does not overload the proximity switch.
- ▶ The power supply must comply with the regulations for extra low voltages with protective electrical separation (SELV, PELV) in accordance with VDE 0100, Part 410.
- ▶ Ensure the wiring and EMC requirements of IEC 60204-1 are met.

Important for detection of shorts across contacts:

As this function for detecting shorts across contacts is not failsafe, it is tested by Pilz during the final control check. If there is a danger of exceeding the cable length, we recommend the following test once the unit is installed:

1. Unit ready for operation (output contacts closed)
2. Short circuit the test terminals S22, S32 for detecting shorts across the inputs.

Safety relays PNOZ X PNOZ X3.10P

3. The unit's fuse must be triggered and the output contacts must open. Cable lengths in the scale of the maximum length can delay the fuse triggering for up to 2 minutes.
4. Reset the fuse: Remove the short circuit and switch off the supply voltage for approx. 1 minute.

Preparing for operation

| Supply voltage | AC | DC |
|---|----------------|--------------|
| | | |
| Input circuit | Single-channel | Dual-channel |
| E-STOP without detection of shorts across contacts | | |
| E-STOP with detection of shorts across contacts | | |
| Safety gate without detection of shorts across contacts | | |
| Safety gate with detection of shorts across contacts | | |

Safety relays PNOZ X PNOZ X3.10P



| Input circuit | Single-channel | Dual-channel |
|--|--|---|
| Light guard or safety switch, detection of shorts across contacts via ESPE | | |
| Start circuit | E-STOP wiring Safety gate without start-up test | Safety gate (dual-channel) with start-up test |
| Automatic start | | |
| Manual start | | |
| Monitored start | | |
| Feedback loop | Automatic start | Monitored start |
| Contacts from external contactors | | |

Safety relays PNOZ X PNOZ X3.10P

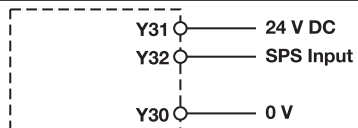
Semiconductor output



Legend

- ▶ S1/S2: E-STOP/safety gate switch
- ▶ S3: Reset button
- ▶ ↑↑: Switch operated
- ▶ : Gate open
- ▶ : Gate closed

Dimensions in mm

* with spring-loaded terminals

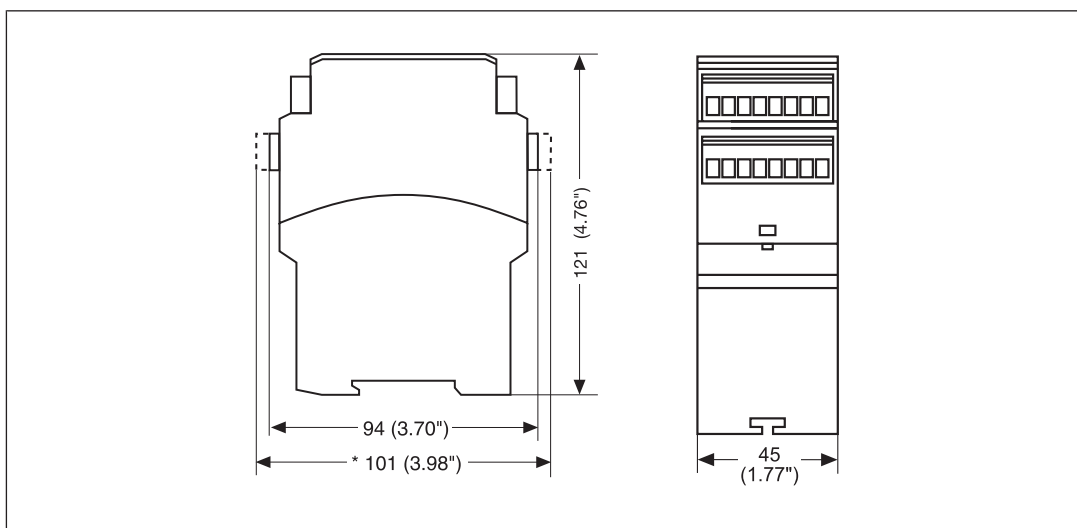

Safety relays PNOZ X PNOZ X3.10P

Technical details

| General | 777314 | 787314 |
|--------------------------------------|--|--|
| Approvals | CCC, CE, EAC (Eurasian), TÜV, cULus Listed | CCC, CE, EAC (Eurasian), TÜV, cULus Listed |
| Electrical data | 777314 | 787314 |
| Supply voltage | | |
| Voltage | 24 V | 24 V |
| Kind | AC/DC | AC/DC |
| Voltage tolerance | -15 %/+10 % | -15 %/+10 % |
| Output of external power supply (AC) | 5 VA | 5 VA |
| Output of external power supply (DC) | 2,5 W | 2,5 W |
| Frequency range AC | 50 - 60 Hz | 50 - 60 Hz |
| Residual ripple DC | 160 % | 160 % |
| Duty cycle | 100 % | 100 % |
| Max. inrush current impulse | | |
| Current pulse, A1 | 1,7 A | 1,7 A |
| Pulse duration, A1 | 7 ms | 7 ms |
| Inputs | 777314 | 787314 |
| Number | 2 | 2 |
| Voltage at | | |
| Input circuit DC | 24 V | 24 V |
| Start circuit DC | 24 V | 24 V |
| Feedback loop DC | 24 V | 24 V |
| Current at | | |
| Input circuit DC | 40 mA | 40 mA |
| Start circuit DC | 70 mA | 70 mA |
| Feedback loop DC | 20 mA | 20 mA |
| Min. input resistance at power-on | 90 Ohm | 90 Ohm |

Safety relays PNOZ X PNOZ X3.10P

| Inputs | 777314 | 787314 |
|---|--------------|--------------|
| Max. overall cable resistance RI-max | | |
| Single-channel at UB DC | 150 Ohm | 150 Ohm |
| Single-channel at UB AC | 180 Ohm | 180 Ohm |
| Dual-channel without detection of shorts across contacts at UB DC | 300 Ohm | 300 Ohm |
| Dual-channel without detection of shorts across contacts at UB AC | 360 Ohm | 360 Ohm |
| Dual-channel with detection of shorts across contacts at UB DC | 15 Ohm | 15 Ohm |
| Dual-channel with detection of shorts across contacts at UB AC | 30 Ohm | 30 Ohm |
| Semiconductor outputs | 777314 | 787314 |
| Number | 1 | 1 |
| Voltage | 24 V | 24 V |
| Current | 20 mA | 20 mA |
| External supply voltage | 24 V | 24 V |
| Voltage tolerance | -20 %/+20 % | -20 %/+20 % |
| Relay outputs | 777314 | 787314 |
| Number of output contacts | | |
| Safety contacts (N/O), instantaneous | 3 | 3 |
| Auxiliary contacts (N/C) | 1 | 1 |
| Max. short circuit current IK | 1 kA | 1 kA |
| Utilisation category | | |
| In accordance with the standard | EN 60947-4-1 | EN 60947-4-1 |
| Utilisation category of safety contacts | | |
| AC1 at | 240 V | 240 V |
| Min. current | 0,01 A | 0,01 A |
| Max. current | 8 A | 8 A |
| Max. power | 2000 VA | 2000 VA |
| DC1 at | 24 V | 24 V |
| Min. current | 0,01 A | 0,01 A |
| Max. current | 8 A | 8 A |
| Max. power | 200 W | 200 W |

Safety relays PNOZ X PNOZ X3.10P

| Relay outputs | 777314 | 787314 |
|---|---------------------------|---------------------------|
| Utilisation category of auxiliary contacts | | |
| AC1 at | 240 V | 240 V |
| Min. current | 0,01 A | 0,01 A |
| Max. current | 8 A | 8 A |
| Max. power | 2000 VA | 2000 VA |
| DC1 at | 24 V | 24 V |
| Min. current | 0,01 A | 0,01 A |
| Max. current | 8 A | 8 A |
| Max. power | 200 W | 200 W |
| Utilisation category | | |
| In accordance with the standard | EN 60947-5-1 | EN 60947-5-1 |
| Utilisation category of safety contacts | | |
| AC15 at | 230 V | 230 V |
| Max. current | 5 A | 5 A |
| DC13 (6 cycles/min) at | 24 V | 24 V |
| Max. current | 6 A | 6 A |
| Utilisation category of auxiliary contacts | | |
| AC15 at | 230 V | 230 V |
| Max. current | 5 A | 5 A |
| DC13 (6 cycles/min) at | 24 V | 24 V |
| Max. current | 6 A | 6 A |
| Utilisation category in accordance with UL | | |
| Voltage | 240 V AC G. P. | 240 V AC G. P. |
| With current | 8 A | 8 A |
| Voltage | 24 V DC Resistive | 24 V DC Resistive |
| With current | 5 A | 5 A |
| Pilot Duty | B300, R300 | B300, R300 |
| External contact fuse protection, safety contacts | | |
| In accordance with the standard | EN 60947-5-1 | EN 60947-5-1 |
| Max. melting integral | 240 A²s | 240 A²s |
| Blow-out fuse, quick | 10 A | 10 A |
| Blow-out fuse, slow | 6 A | 6 A |
| Blow-out fuse, gG | 10 A | 10 A |
| Circuit breaker 24V AC/DC, characteristic B/C | 6 A | 6 A |

Safety relays PNOZ X PNOZ X3.10P

| Relay outputs | 777314 | 787314 |
|--|--------------------------------|--------------------------------|
| External contact fuse protection, auxiliary contacts | | |
| Max. melting integral | 240 A ² s | 240 A ² s |
| Blow-out fuse, quick | 10 A | 10 A |
| Blow-out fuse, slow | 6 A | 6 A |
| Blow-out fuse, gG | 10 A | 10 A |
| Circuit breaker 24 V AC/DC, characteristic B/C | 6 A | 6 A |
| Contact material | AgSnO ₂ + 0,2 µm Au | AgSnO ₂ + 0,2 µm Au |
| Conventional thermal current while loading several contacts | 777314 | 787314 |
| I _{th} per contact at UB AC; AC1: 240 V, DC1: 24 V | | |
| Conv. therm. current with 1 contact | 8 A | 8 A |
| Conv. therm. current with 2 contacts | 7 A | 7 A |
| Conv. therm. current with 3 contacts | 6 A | 6 A |
| I _{th} per contact at UB DC; AC1: 240 V, DC1: 24 V | | |
| Conv. therm. current with 1 contact | 8 A | 8 A |
| Conv. therm. current with 2 contacts | 8 A | 8 A |
| Conv. therm. current with 3 contacts | 7 A | 7 A |
| Times | 777314 | 787314 |
| Switch-on delay | | |
| With automatic start typ. | 250 ms | 250 ms |
| With automatic start max. | 500 ms | 500 ms |
| With automatic start after power on typ. | 280 ms | 280 ms |
| With automatic start after power on max. | 550 ms | 550 ms |
| With manual start typ. | 200 ms | 200 ms |
| With manual start max. | 500 ms | 500 ms |
| With monitored start typ. | 35 ms | 35 ms |
| With monitored start max. | 50 ms | 50 ms |

Safety relays PNOZ X PNOZ X3.10P

| Times | 777314 | 787314 |
|--|---|---|
| Delay-on de-energisation | | |
| With E-STOP typ. | 15 ms | 15 ms |
| With E-STOP max. | 30 ms | 30 ms |
| With power failure typ. | 180 ms | 180 ms |
| With power failure max. | 260 ms | 260 ms |
| Recovery time at max. switching frequency 1/s | | |
| After E-STOP | 50 ms | 50 ms |
| After power failure | 350 ms | 350 ms |
| Waiting period with a monitored start | | |
| | 300 ms | 300 ms |
| Min. start pulse duration with a monitored start | | |
| | 30 ms | 30 ms |
| Supply interruption before de-energisation | | |
| | 150 ms | 150 ms |
| Simultaneity, channel 1 and 2 max. | | |
| | ∞ | ∞ |
| Environmental data | 777314 | 787314 |
| Climatic suitability | | |
| | EN 60068-2-78 | EN 60068-2-78 |
| Ambient temperature | | |
| Temperature range | -20 - 55 °C | -20 - 55 °C |
| Storage temperature | | |
| Temperature range | -40 - 85 °C | -40 - 85 °C |
| Climatic suitability | | |
| Humidity | 93 % r. h. at 40 °C | 93 % r. h. at 40 °C |
| Condensation during operation | | |
| | Not permitted | Not permitted |
| EMC | | |
| | EN 60947-5-1, EN 61000-6-2, EN 61326-3-1 | EN 60947-5-1, EN 61000-6-2, EN 61326-3-1 |
| Vibration | | |
| In accordance with the standard | EN 60068-2-6 | EN 60068-2-6 |
| Frequency | 10 - 55 Hz | 10 - 55 Hz |
| Amplitude | 0,35 mm | 0,35 mm |
| Airgap creepage | | |
| In accordance with the standard | EN 60947-1 | EN 60947-1 |
| Overvoltage category | III / II | III / II |
| Pollution degree | 2 | 2 |
| Rated insulation voltage | | |
| | 250 V | 250 V |
| Rated impulse withstand voltage | | |
| | 4 kV | 4 kV |
| Protection type | | |
| Mounting area (e.g. control cabinet) | IP54 | IP54 |
| Housing | IP40 | IP40 |
| Terminals | IP20 | IP20 |

Safety relays PNOZ X PNOZ X3.10P

| Mechanical data | 777314 | 787314 |
|---|---|--|
| Mounting position | Any | Any |
| Mechanical life | 10,000,000 cycles | 10,000,000 cycles |
| Material | | |
| Bottom | PPO UL 94 V0 | PPO UL 94 V0 |
| Front | ABS UL 94 V0 | ABS UL 94 V0 |
| Top | PPO UL 94 V0 | PPO UL 94 V0 |
| Connection type | Screw terminal | Spring-loaded terminal |
| Mounting type | plug-in | plug-in |
| Conductor cross section with screw terminals | | |
| 1 core flexible | 0,25 - 2,5 mm², 24 - 12 AWG | – |
| 2 core with the same cross section, flexible with crimp connectors, no plastic sleeve | 0,25 - 1 mm², 24 - 16 AWG | – |
| 2 core with the same cross section, flexible without crimp connectors or with TWIN crimp connectors | 0,2 - 1,5 mm², 24 - 16 AWG | – |
| Torque setting with screw terminals | 0,5 Nm | – |
| Conductor cross section with spring-loaded terminals: Flexible with/without crimp connector | – | 0,2 - 1,5 mm², 24 - 16 AWG |
| Spring-loaded terminals: Terminal points per connection | – | 2 |
| Stripping length with spring-loaded terminals | – | 8 mm |
| Dimensions | | |
| Height | 94 mm | 101 mm |
| Width | 45 mm | 45 mm |
| Depth | 121 mm | 121 mm |
| Weight | 290 g | 290 g |

Where standards are undated, the 2014-07 latest editions shall apply.

Safety relays PNOZ X PNOZ X3.10P

Safety characteristic data

| Operating Mode | EN ISO 13849-1: 2015 PL | EN ISO 13849-1: 2015 Category | EN 62061 SIL CL | EN 62061 PFH _D [1/h] | IEC 61511 SIL | IEC 61511 PFD | EN ISO 13849-1: 2015 T _M [year] |
|----------------|----------------------------|----------------------------------|--------------------|------------------------------------|------------------|------------------|---|
| – | PL e | Cat. 4 | SIL CL 3 | 2,31E-09 | SIL 3 | 2,03E-06 | 20 |

All the units used within a safety function must be considered when calculating the safety characteristic data.

Supplementary data

The PFH value depends on the switching frequency and the load on the relay output. If the service life graphs are not accessible, the stated PFH value can be used irrespective of the switching frequency and the load, as the PFH value already considers the relay's B10d value as well as the failure rates of the other components.

Safety relays PNOZ X PNOZ X3.10P

Service life graph

The service life graphs indicate the number of cycles from which failures due to wear must be expected. The wear is mainly caused by the electrical load; the mechanical load is negligible.

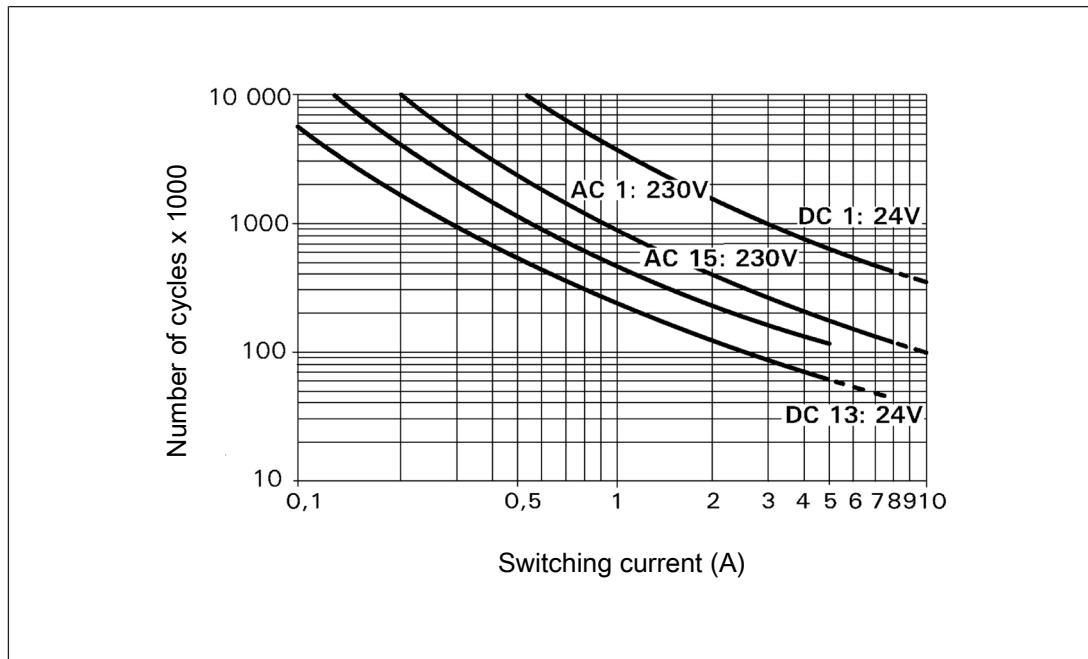

Example

- ▶ Inductive load: 0.2 A
- ▶ Utilisation category: AC15
- ▶ Contact service life: 4 000 000 cycles

Provided the application to be implemented requires fewer than 4 000 000 cycles, the PFH value (see Technical details) can be used in the calculation.

To increase the service life, sufficient spark suppression must be provided on all output contacts. With capacitive loads, any power surges that occur must be noted. With DC contactors, use flywheel diodes for spark suppression.

Order reference

| Product type | Features | Connection type | Order no. |
|---------------|-----------|-------------------------|-----------|
| PNOZ X3.10P C | 24 VAC/DC | Spring-loaded terminals | 787 314 |
| PNOZ X3.10P | 24 VAC/DC | Screw terminals | 777 314 |

Safety relays PNOZ X PNOZ X7P

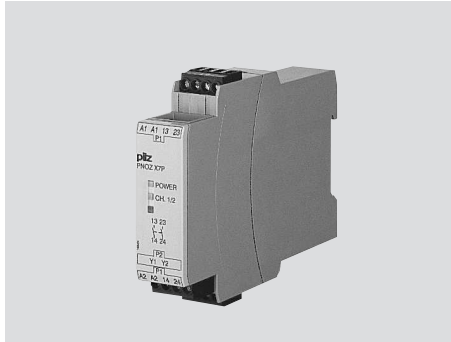

Unit features

- ▶ Positive-guided relay outputs:
 - 2 safety contacts (N/O), instantaneous
- ▶ Connection options for:
 - E-STOP pushbutton
 - Safety gate limit switch
 - Start button
- ▶ LED display for:
 - Supply voltage
 - Switch status of the safety contacts
- ▶ Plug-in connection terminals
- ▶ See order reference for unit types

Safety relays PNOZ X PNOZ X7P

Block diagram/terminal configuration

Types: AC

- ▶ U_B : 110 - 120 VAC; Order no. 777053, 787053
- ▶ U_B : 230 - 240 VAC; Order no. 777056, 787056

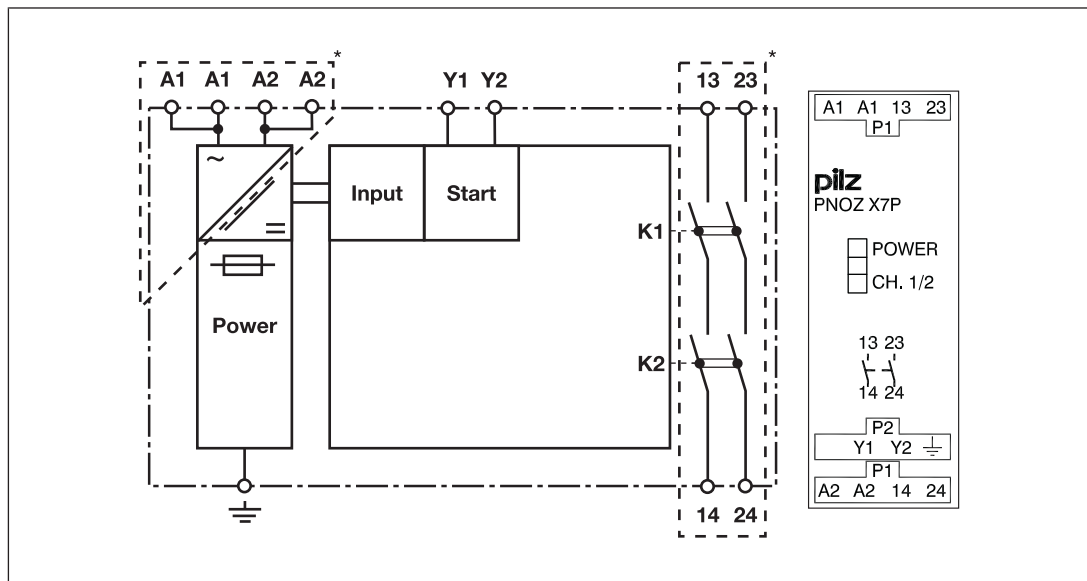

*Insulation between the non-marked area and the relay contacts: Basic insulation (over-voltage category III), Protective separation (over-voltage category II)

Safety relays PNOZ X PNOZ X7P

Types: AC/DC

- ▶ U_B : 24 VAC/DC; Order no. 777059, 787059

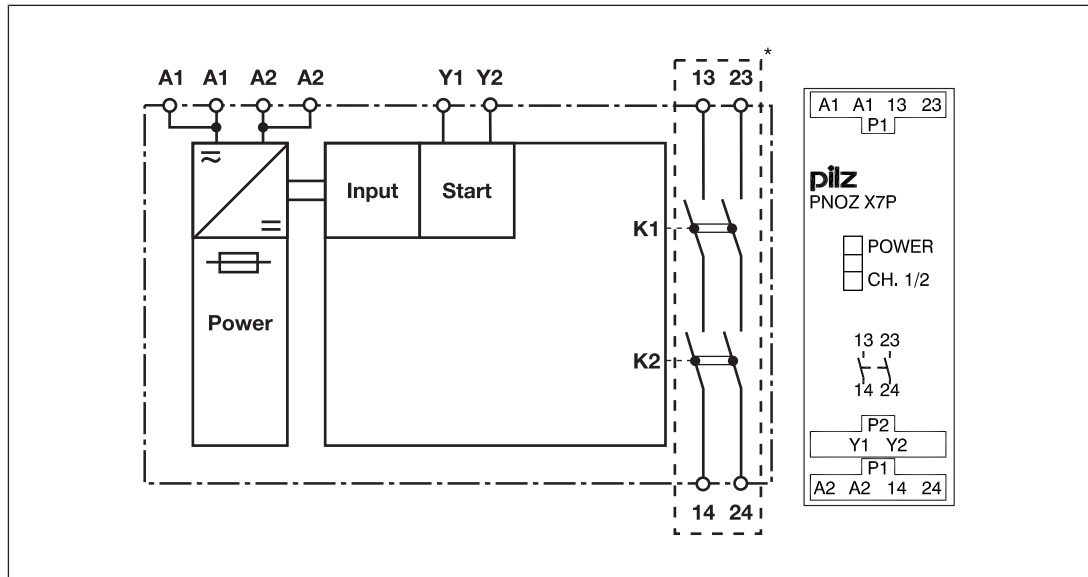

*Insulation between the non-marked area and the relay contacts: Basic insulation (over-voltage category III), Protective separation (overvoltage category II)

Function Description

The safety relay PNOZ X7P provides a safety-oriented interruption of a safety circuit. When the supply voltage is applied via the E-STOP pushbutton, the "POWER" LED is lit. The unit is ready for operation when the start circuit and feedback loop Y1-Y2 is closed.

- ▶ Input circuit is closed (e.g. E-STOP pushbutton not operated):
 - The LED "CH. 1/2" lights.
 - Safety contacts 13-14 and 23-24 are closed. The unit is active.
- ▶ Input circuit is opened (e.g. E-STOP pushbutton operated):
 - The LED "CH. 1/2" goes out.
 - Safety contacts 13-14 and 23-24 are redundantly opened.

Operating modes

- ▶ Single-channel operation: No redundancy in the input circuit, earth faults in the start and input circuit are detected.
- ▶ Automatic start: Unit is active once the input circuit has been closed.
- ▶ Manual start: Unit is active once the input circuit and the start circuit are closed.
- ▶ Increase in the number of available contacts by connecting contact expander modules or external contactors/relays.

Safety relays PNOZ X PNOZ X7P

Timing diagram

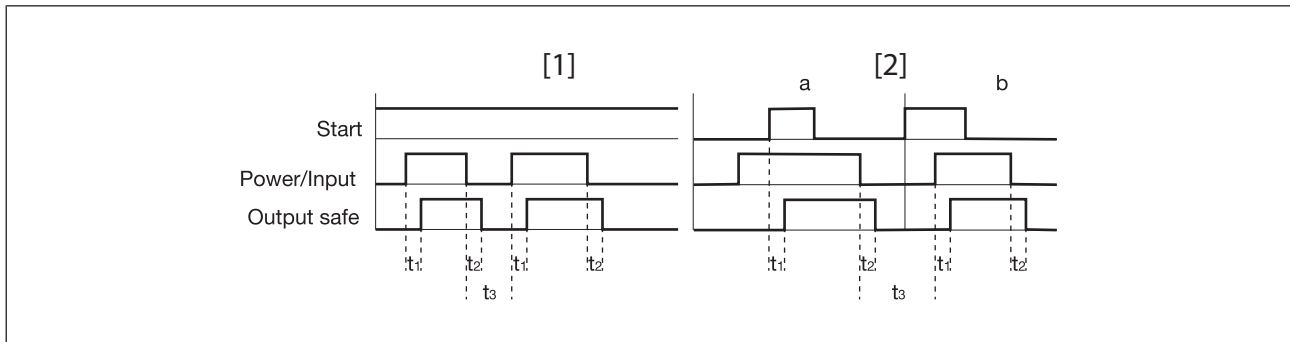

Legend

- ▶ Power: Supply voltage
- ▶ Start: Start circuit
- ▶ Input: Input circuit
- ▶ Output safe: Safety contacts
- ▶ [1]: Automatic start
- ▶ [2]: Manual start
- ▶ a: Input circuit closes before start circuit
- ▶ b: Start circuit closes before input circuit
- ▶ t_1 : Switch-on delay
- ▶ t_2 : Delay-on de-energisation
- ▶ t_3 : Recovery time

Installation

- ▶ The unit should be installed in a control cabinet with a protection type of at least IP54.
- ▶ Use the notch on the rear of the unit to attach it to a DIN rail.
- ▶ Ensure the unit is mounted securely on a vertical DIN rail (35 mm) by using a fixing element (e.g. retaining bracket or an end angle).

Safety relays PNOZ X PNOZ X7P

Wiring

Please note:

- ▶ Information given in the "Technical details [168]" must be followed.
- ▶ Calculating the max. cable length I_{max} in the input circuit on PNOZ X7P 24 VAC/DC:

$$I_{max} = \frac{R_{I_{max}}}{R_l / km}$$

$R_{I_{max}}$ = max. overall cable resistance (see Technical details [168])

R_l / km = cable resistance/km

- ▶ Calculating the max. cable length I_{max} in the input circuit on PNOZ X7P AC units:

$$I_{max} = \frac{C_{I_{max}}}{C_l / km}$$

$C_{I_{max}}$ = max. overall line capacitance (see Technical details [168])

C_l / km = line capacitance/km

Stub circuit: The max. permitted cable length I_{max} depends on the max. overall line capacitance $C_{I_{max}}$ (see Technical details [168]).

Alternative: Loop circuit: Capacitance is negligible; 1 phase: Max. cable length I_{max} : 1 km

| | Stub circuit | Loop circuit |
|--------------|--------------|--------------|
| Cable length | | |

- ▶ The outputs 13-14, 23-24 are safety contacts.
- ▶ Do not connect undesignated terminals.
- ▶ To prevent contact welding, a fuse should be connected before the output contacts (see Technical details [168]).
- ▶ Use copper wire that can withstand 60/75 °C.
- ▶ Sufficient fuse protection must be provided on all output contacts with capacitive and inductive loads.
- ▶ Do not switch low currents using contacts that have been used previously with high currents.
- ▶ On AC units: Connect operational earth terminal to functional earth.
- ▶ On 24 VAC/DC units:
The power supply must comply with the regulations for extra low voltages with safe electrical separation (SELV, PELV) in accordance with VDE 0100, Part 410.
- ▶ Ensure the wiring and EMC requirements of IEC 60204-1 are met.

Safety relays PNOZ X PNOZ X7P

Preparing for operation

| Supply voltage | AC | 24 VAC/DC |
|-----------------------------------|-----------------|--------------|
| | | |
| Input circuit | Single-channel | Dual-channel |
| E-STOP | | |
| Safety gate | | |
| Start circuit | Automatic start | Manual start |
| | | |
| Feedback loop | Automatic start | Manual start |
| Contacts from external contactors | | |

Legend

- ▶ S1: E-STOP/safety gate switch
- ▶ S3: Start button
- ▶ : Gate open

Safety relays PNOZ X PNOZ X7P

▶  Gate closed

Dimensions in mm

* with spring-loaded terminals

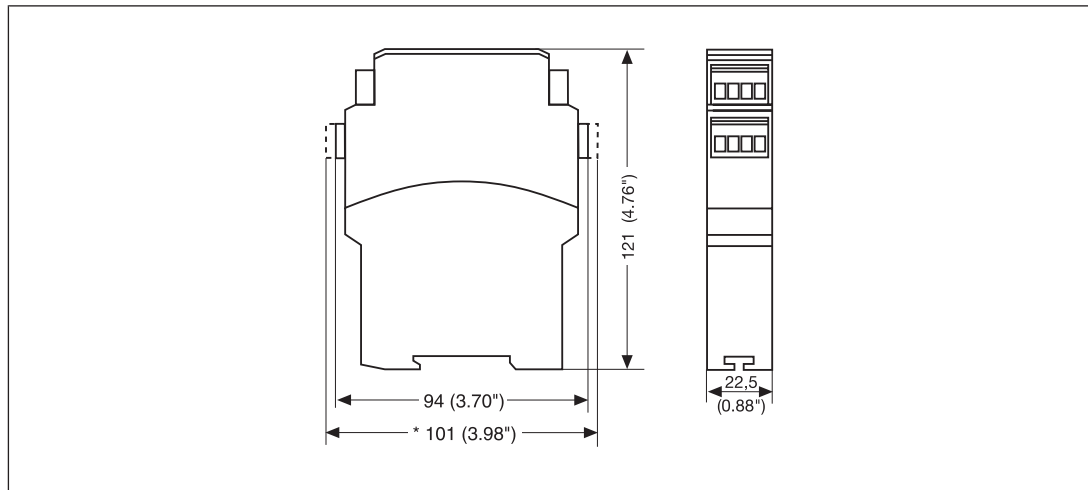

Technical details

Order no. 777053 – 777059

See below for more order numbers

| General | 777053 | 777056 | 777059 |
|--------------------------------------|--|--|--|
| Approvals | CCC, CE, EAC (Eurasian), TÜV, cULus Listed | CCC, CE, EAC (Eurasian), TÜV, cULus Listed | CCC, CE, EAC (Eurasian), TÜV, cULus Listed |
| Electrical data | 777053 | 777056 | 777059 |
| Supply voltage | | | |
| Voltage | 110 - 120 V | 230 - 240 V | 24 V |
| Kind | AC | AC | AC/DC |
| Voltage tolerance | -15 %/+10 % | -15 %/+10 % | -15 %/+10 % |
| Output of external power supply (AC) | 2 VA | 2 VA | 3 VA |
| Output of external power supply (DC) | – | – | 1,5 W |
| Frequency range AC | 50 - 60 Hz | 50 - 60 Hz | 50 - 60 Hz |
| Residual ripple DC | – | – | 160 % |
| Duty cycle | 100 % | 100 % | 100 % |
| Max. inrush current impulse | | | |
| Current pulse, A1 | – | – | 1,7 A |
| Pulse duration, A1 | – | – | 8 ms |

Safety relays PNOZ X PNOZ X7P

| Inputs | 777053 | 777056 | 777059 |
|---|---------------|---------------|---------------|
| Number | 1 | 1 | 1 |
| Voltage at | | | |
| Input circuit DC | 110 - 120 V | 230 - 240 V | 24 V |
| Start circuit DC | 24 V | 24 V | 24 V |
| Feedback loop DC | 24 V | 24 V | 24 V |
| Current at | | | |
| Input circuit DC | 17 mA | 8 mA | 50 mA |
| Start circuit DC | 40 mA | 40 mA | 210 mA |
| Feedback loop DC | 40 mA | 40 mA | 210 mA |
| Max. overall cable resistance R _{lmax} | | | |
| Single-channel at UB DC | – | – | 15 Ohm |
| Single-channel at UB AC | – | – | 15 Ohm |
| Max. overall line capacitance C _{lmax} | 37 nF | 7 nF | – |
| Relay outputs | 777053 | 777056 | 777059 |
| Number of output contacts | | | |
| Safety contacts (N/O), instantaneous | 2 | 2 | 2 |
| Max. short circuit current I _K | 1 kA | 1 kA | 1 kA |
| Utilisation category | | | |
| In accordance with the standard | EN 60947-4-1 | EN 60947-4-1 | EN 60947-4-1 |
| Utilisation category of safety contacts | | | |
| AC1 at | 240 V | 240 V | 240 V |
| Min. current | 0,01 A | 0,01 A | 0,01 A |
| Max. current | 4 A | 4 A | 6 A |
| Max. power | 1000 VA | 1000 VA | 1500 VA |
| DC1 at | 24 V | 24 V | 24 V |
| Min. current | 0,01 A | 0,01 A | 0,01 A |
| Max. current | 4 A | 4 A | 6 A |
| Max. power | 100 W | 100 W | 150 W |
| Utilisation category | | | |
| In accordance with the standard | EN 60947-5-1 | EN 60947-5-1 | EN 60947-5-1 |

Safety relays PNOZ X PNOZ X7P

| Relay outputs | 777053 | 777056 | 777059 |
|--|--------------------------------|--------------------------------|--------------------------------|
| Utilisation category of safety contacts | | | |
| AC15 at | 230 V | 230 V | 230 V |
| Max. current | 4 A | 4 A | 5 A |
| DC13 (6 cycles/min) at | 24 V | 24 V | 24 V |
| Max. current | 4 A | 4 A | 6 A |
| Utilisation category in accordance with UL | | | |
| Voltage | 240 V AC G. P. | 240 V AC G. P. | 240 V AC G. P. |
| With current | 4 A | 4 A | 6 A |
| Voltage | 24 V DC Resistive | 24 V DC Resistive | 24 V DC Resistive |
| With current | 4 A | 4 A | 6 A |
| Pilot Duty | C300, R300 | C300, R300 | C300, R300 |
| External contact fuse protection, safety contacts | | | |
| In accordance with the standard | EN 60947-5-1 | EN 60947-5-1 | EN 60947-5-1 |
| Max. melting integral | 240 A ² s | 240 A ² s | 240 A ² s |
| Blow-out fuse, quick | 4 A | 4 A | 6 A |
| Blow-out fuse, slow | 4 A | 4 A | 4 A |
| Blow-out fuse, gG | 4 A | 4 A | 6 A |
| Circuit breaker 24V AC/DC, characteristic B/C | 4 A | 4 A | 4 A |
| Conventional thermal current | – | – | 6 A |
| Contact material | AgSnO ₂ + 0,2 µm Au | AgSnO ₂ + 0,2 µm Au | AgSnO ₂ + 0,2 µm Au |
| Conventional thermal current while loading several contacts | 777053 | 777056 | 777059 |
| I _{th} per contact at UB AC; AC1: 240 V, DC1: 24 V | | | |
| Conv. therm. current with 1 contact | 4 A | 4 A | – |
| Conv. therm. current with 2 contacts | 3 A | 3 A | – |

Safety relays PNOZ X PNOZ X7P

| Times | 777053 | 777056 | 777059 |
|---|--|--|--|
| Switch-on delay | | | |
| With automatic start typ. | 230 ms | 230 ms | 50 ms |
| With automatic start max. | 700 ms | 700 ms | 150 ms |
| With automatic start after power on typ. | 230 ms | 230 ms | 50 ms |
| With automatic start after power on max. | 700 ms | 700 ms | 150 ms |
| With manual start typ. | 140 ms | 140 ms | 35 ms |
| With manual start max. | 700 ms | 700 ms | 150 ms |
| Delay-on de-energisation | | | |
| With E-STOP typ. | 70 ms | 70 ms | 45 ms |
| With E-STOP max. | 100 ms | 100 ms | 70 ms |
| With power failure typ. | 70 ms | 70 ms | 45 ms |
| With power failure max. | 100 ms | 100 ms | 70 ms |
| Recovery time at max. switching frequency 1/s | | | |
| After E-STOP | 120 ms | 120 ms | 50 ms |
| After power failure | 120 ms | 120 ms | 150 ms |
| Supply interruption before de-energisation | 20 ms | 20 ms | 20 ms |
| Environmental data | 777053 | 777056 | 777059 |
| Climatic suitability | EN 60068-2-78 | EN 60068-2-78 | EN 60068-2-78 |
| Ambient temperature | | | |
| Temperature range | -10 - 55 °C | -10 - 55 °C | -10 - 55 °C |
| Storage temperature | | | |
| Temperature range | -40 - 85 °C | -40 - 85 °C | -40 - 85 °C |
| Climatic suitability | | | |
| Humidity | 93 % r. h. at 40 °C | 93 % r. h. at 40 °C | 93 % r. h. at 40 °C |
| Condensation during operation | | | |
| | Not permitted | Not permitted | Not permitted |
| EMC | | | |
| | EN 60947-5-1, EN 61000-6-2, EN 61326-3-1 | EN 60947-5-1, EN 61000-6-2, EN 61326-3-1 | EN 60947-5-1, EN 61000-6-2, EN 61326-3-1 |
| Vibration | | | |
| In accordance with the standard | EN 60068-2-6 | EN 60068-2-6 | EN 60068-2-6 |
| Frequency | 10 - 55 Hz | 10 - 55 Hz | 10 - 55 Hz |
| Amplitude | 0,35 mm | 0,35 mm | 0,35 mm |

Safety relays PNOZ X PNOZ X7P

| Environmental data | 777053 | 777056 | 777059 |
|---|---|---|---|
| Airgap creepage | | | |
| In accordance with the standard | EN 60947-1 | EN 60947-1 | EN 60947-1 |
| Overvoltage category | III / II | III / II | III / II |
| Pollution degree | 2 | 2 | 2 |
| Rated insulation voltage | 250 V | 250 V | 250 V |
| Rated impulse withstand voltage | 4 kV | 4 kV | 4 kV |
| Protection type | | | |
| Mounting area (e.g. control cabinet) | IP54 | IP54 | IP54 |
| Housing | IP40 | IP40 | IP40 |
| Terminals | IP20 | IP20 | IP20 |
| Mechanical data | 777053 | 777056 | 777059 |
| Mounting position | Any | Any | Any |
| Mechanical life | 10,000,000 cycles | 10,000,000 cycles | 10,000,000 cycles |
| Material | | | |
| Bottom | PPO UL 94 V0 | PPO UL 94 V0 | PPO UL 94 V0 |
| Front | ABS UL 94 V0 | ABS UL 94 V0 | ABS UL 94 V0 |
| Top | PPO UL 94 V0 | PPO UL 94 V0 | PPO UL 94 V0 |
| Connection type | Screw terminal | Screw terminal | Screw terminal |
| Mounting type | plug-in | plug-in | plug-in |
| Conductor cross section with screw terminals | | | |
| 1 core flexible | 0,25 - 2,5 mm², 24 - 12 AWG | 0,25 - 2,5 mm², 24 - 12 AWG | 0,25 - 2,5 mm², 24 - 12 AWG |
| 2 core with the same cross section, flexible with crimp connectors, no plastic sleeve | 0,25 - 1 mm², 24 - 16 AWG | 0,25 - 1 mm², 24 - 16 AWG | 0,25 - 1 mm², 24 - 16 AWG |
| 2 core with the same cross section, flexible without crimp connectors or with TWIN crimp connectors | 0,2 - 1,5 mm², 24 - 16 AWG | 0,2 - 1,5 mm², 24 - 16 AWG | 0,2 - 1,5 mm², 24 - 16 AWG |
| Torque setting with screw terminals | 0,5 Nm | 0,5 Nm | 0,5 Nm |
| Dimensions | | | |
| Height | 94 mm | 94 mm | 94 mm |
| Width | 22,5 mm | 22,5 mm | 22,5 mm |
| Depth | 121 mm | 121 mm | 121 mm |
| Weight | 230 g | 230 g | 190 g |

Where standards are undated, the 2014-07 latest editions shall apply.

Safety relays PNOZ X PNOZ X7P

Order no. 787053 – 787059

| General | 787053 | 787056 | 787059 |
|---|--|--|--|
| Approvals | CCC, CE, EAC (Eurasian), TÜV, cULus Listed | CCC, CE, EAC (Eurasian), TÜV, cULus Listed | CCC, CE, EAC (Eurasian), TÜV, cULus Listed |
| Electrical data | 787053 | 787056 | 787059 |
| Supply voltage | | | |
| Voltage | 110 - 120 V | 230 - 240 V | 24 V |
| Kind | AC | AC | AC/DC |
| Voltage tolerance | -15 %/+10 % | -15 %/+10 % | -15 %/+10 % |
| Output of external power supply (AC) | 2 VA | 2 VA | 3 VA |
| Output of external power supply (DC) | – | – | 1,5 W |
| Frequency range AC | 50 - 60 Hz | 50 - 60 Hz | 50 - 60 Hz |
| Residual ripple DC | – | – | 160 % |
| Duty cycle | 100 % | 100 % | 100 % |
| Max. inrush current impulse | | | |
| Current pulse, A1 | – | – | 1,7 A |
| Pulse duration, A1 | – | – | 8 ms |
| Inputs | 787053 | 787056 | 787059 |
| Number | 1 | 1 | 1 |
| Voltage at | | | |
| Input circuit DC | 110 - 120 V | 230 - 240 V | 24 V |
| Start circuit DC | 24 V | 24 V | 24 V |
| Feedback loop DC | 24 V | 24 V | 24 V |
| Current at | | | |
| Input circuit DC | 17 mA | 8 mA | 50 mA |
| Start circuit DC | 40 mA | 40 mA | 210 mA |
| Feedback loop DC | 40 mA | 40 mA | 210 mA |
| Max. overall cable resistance R _{lmax} | | | |
| Single-channel at UB DC | – | – | 15 Ohm |
| Single-channel at UB AC | – | – | 15 Ohm |
| Max. overall line capacitance C _{lmax} | 37 nF | 7 nF | – |

Safety relays PNOZ X PNOZ X7P

| Relay outputs | 787053 | 787056 | 787059 |
|--|-------------------|-------------------|-------------------|
| Number of output contacts | | | |
| Safety contacts (N/O), instantaneous | 2 | 2 | 2 |
| Max. short circuit current IK | 1 kA | 1 kA | 1 kA |
| Utilisation category | | | |
| In accordance with the standard | EN 60947-4-1 | EN 60947-4-1 | EN 60947-4-1 |
| Utilisation category of safety contacts | | | |
| AC1 at | 240 V | 240 V | 240 V |
| Min. current | 0,01 A | 0,01 A | 0,01 A |
| Max. current | 4 A | 4 A | 6 A |
| Max. power | 1000 VA | 1000 VA | 1500 VA |
| DC1 at | 24 V | 24 V | 24 V |
| Min. current | 0,01 A | 0,01 A | 0,01 A |
| Max. current | 4 A | 4 A | 6 A |
| Max. power | 100 W | 100 W | 150 W |
| Utilisation category | | | |
| In accordance with the standard | EN 60947-5-1 | EN 60947-5-1 | EN 60947-5-1 |
| Utilisation category of safety contacts | | | |
| AC15 at | 230 V | 230 V | 230 V |
| Max. current | 4 A | 4 A | 5 A |
| DC13 (6 cycles/min) at | 24 V | 24 V | 24 V |
| Max. current | 4 A | 4 A | 6 A |
| Utilisation category in accordance with UL | | | |
| Voltage | 240 V AC G. P. | 240 V AC G. P. | 240 V AC G. P. |
| With current | 4 A | 4 A | 6 A |
| Voltage | 24 V DC Resistive | 24 V DC Resistive | 24 V DC Resistive |
| With current | 4 A | 4 A | 6 A |
| Pilot Duty | C300, R300 | C300, R300 | C300, R300 |

Safety relays PNOZ X PNOZ X7P

| Relay outputs | 787053 | 787056 | 787059 |
|--|--------------------------------------|--------------------------------------|--------------------------------------|
| External contact fuse protection, safety contacts | | | |
| In accordance with the standard | EN 60947-5-1 | EN 60947-5-1 | EN 60947-5-1 |
| Max. melting integral | 240 A²s | 240 A²s | 240 A²s |
| Blow-out fuse, quick | 4 A | 4 A | 6 A |
| Blow-out fuse, slow | 4 A | 4 A | 4 A |
| Blow-out fuse, gG | 4 A | 4 A | 6 A |
| Circuit breaker 24V AC/DC, characteristic B/C | 4 A | 4 A | 4 A |
| Conventional thermal current | – | – | 6 A |
| Contact material | AgSnO₂ + 0,2 µm Au | AgSnO₂ + 0,2 µm Au | AgSnO₂ + 0,2 µm Au |
| Conventional thermal current while loading several contacts | 787053 | 787056 | 787059 |
| I _{th} per contact at UB AC; AC1: 240 V, DC1: 24 V | | | |
| Conv. therm. current with 1 contact | 4 A | 4 A | – |
| Conv. therm. current with 2 contacts | 3 A | 3 A | – |
| Times | 787053 | 787056 | 787059 |
| Switch-on delay | | | |
| With automatic start typ. | 230 ms | 230 ms | 50 ms |
| With automatic start max. | 700 ms | 700 ms | 150 ms |
| With automatic start after power on typ. | 230 ms | 230 ms | 50 ms |
| With automatic start after power on max. | 700 ms | 700 ms | 150 ms |
| With manual start typ. | 140 ms | 140 ms | 35 ms |
| With manual start max. | 700 ms | 700 ms | 150 ms |
| Delay-on de-energisation | | | |
| With E-STOP typ. | 70 ms | 70 ms | 45 ms |
| With E-STOP max. | 100 ms | 100 ms | 70 ms |
| With power failure typ. | 70 ms | 70 ms | 45 ms |
| With power failure max. | 100 ms | 100 ms | 70 ms |
| Recovery time at max. switching frequency 1/s | | | |
| After E-STOP | 120 ms | 120 ms | 50 ms |
| After power failure | 120 ms | 120 ms | 150 ms |

Safety relays PNOZ X PNOZ X7P

| Times | 787053 | 787056 | 787059 |
|--|--|--|--|
| Supply interruption before de-energisation | 20 ms | 20 ms | 20 ms |
| Environmental data | 787053 | 787056 | 787059 |
| Climatic suitability | EN 60068-2-78 | EN 60068-2-78 | EN 60068-2-78 |
| Ambient temperature | | | |
| Temperature range | -10 - 55 °C | -10 - 55 °C | -10 - 55 °C |
| Storage temperature | | | |
| Temperature range | -40 - 85 °C | -40 - 85 °C | -40 - 85 °C |
| Climatic suitability | | | |
| Humidity | 93 % r. h. at 40 °C | 93 % r. h. at 40 °C | 93 % r. h. at 40 °C |
| Condensation during operation | Not permitted | Not permitted | Not permitted |
| EMC | EN 60947-5-1, EN 61000-6-2, EN 61326-3-1 | EN 60947-5-1, EN 61000-6-2, EN 61326-3-1 | EN 60947-5-1, EN 61000-6-2, EN 61326-3-1 |
| Vibration | | | |
| In accordance with the standard | EN 60068-2-6 | EN 60068-2-6 | EN 60068-2-6 |
| Frequency | 10 - 55 Hz | 10 - 55 Hz | 10 - 55 Hz |
| Amplitude | 0,35 mm | 0,35 mm | 0,35 mm |
| Airgap creepage | | | |
| In accordance with the standard | EN 60947-1 | EN 60947-1 | EN 60947-1 |
| Overvoltage category | III / II | III / II | III / II |
| Pollution degree | 2 | 2 | 2 |
| Rated insulation voltage | 250 V | 250 V | 250 V |
| Rated impulse withstand voltage | 4 kV | 4 kV | 4 kV |
| Protection type | | | |
| Mounting area (e.g. control cabinet) | IP54 | IP54 | IP54 |
| Housing | IP40 | IP40 | IP40 |
| Terminals | IP20 | IP20 | IP20 |
| Mechanical data | 787053 | 787056 | 787059 |
| Mounting position | Any | Any | Any |
| Mechanical life | 10,000,000 cycles | 10,000,000 cycles | 10,000,000 cycles |
| Material | | | |
| Bottom | PPO UL 94 V0 | PPO UL 94 V0 | PPO UL 94 V0 |
| Front | ABS UL 94 V0 | ABS UL 94 V0 | ABS UL 94 V0 |
| Top | PPO UL 94 V0 | PPO UL 94 V0 | PPO UL 94 V0 |
| Connection type | Spring-loaded terminal | Spring-loaded terminal | Spring-loaded terminal |
| Mounting type | plug-in | plug-in | plug-in |

Safety relays PNOZ X PNOZ X7P

| Mechanical data | 787053 | 787056 | 787059 |
|---|---|---|---|
| Conductor cross section with spring-loaded terminals: Flexible with/without crimp connector | 0,2 - 1,5 mm ² , 24 - 16 AWG | 0,2 - 1,5 mm ² , 24 - 16 AWG | 0,2 - 1,5 mm ² , 24 - 16 AWG |
| Spring-loaded terminals: Terminal points per connection | 2 | 2 | 2 |
| Stripping length with spring-loaded terminals | 8 mm | 8 mm | 8 mm |
| Dimensions | | | |
| Height | 101 mm | 101 mm | 101 mm |
| Width | 22,5 mm | 22,5 mm | 22,5 mm |
| Depth | 121 mm | 121 mm | 121 mm |
| Weight | 225 g | 225 g | 190 g |

Where standards are undated, the 2014-07 latest editions shall apply.

Safety characteristic data

| Operating Mode | EN ISO 13849-1: 2015 | EN ISO 13849-1: 2015 | EN 62061 SIL CL | EN 62061 PFH _D [1/h] | IEC 61511 SIL | IEC 61511 PFD | EN ISO 13849-1: 2015 T _M [year] |
|----------------|----------------------|----------------------|-----------------|---------------------------------|---------------|---------------|--|
| PL | Category | | | | | | |
| – | PL e | Cat. 4 | SIL CL 3 | 2,31E-09 | SIL 3 | 2,03E-06 | 20 |

All the units used within a safety function must be considered when calculating the safety characteristic data.

Supplementary data

The PFH value depends on the switching frequency and the load on the relay output. If the service life graphs are not accessible, the stated PFH value can be used irrespective of the switching frequency and the load, as the PFH value already considers the relay's B10d value as well as the failure rates of the other components.

Service life graph

The service life graphs indicate the number of cycles from which failures due to wear must be expected. The wear is mainly caused by the electrical load; the mechanical load is negligible.

Safety relays PNOZ X PNOZ X7P

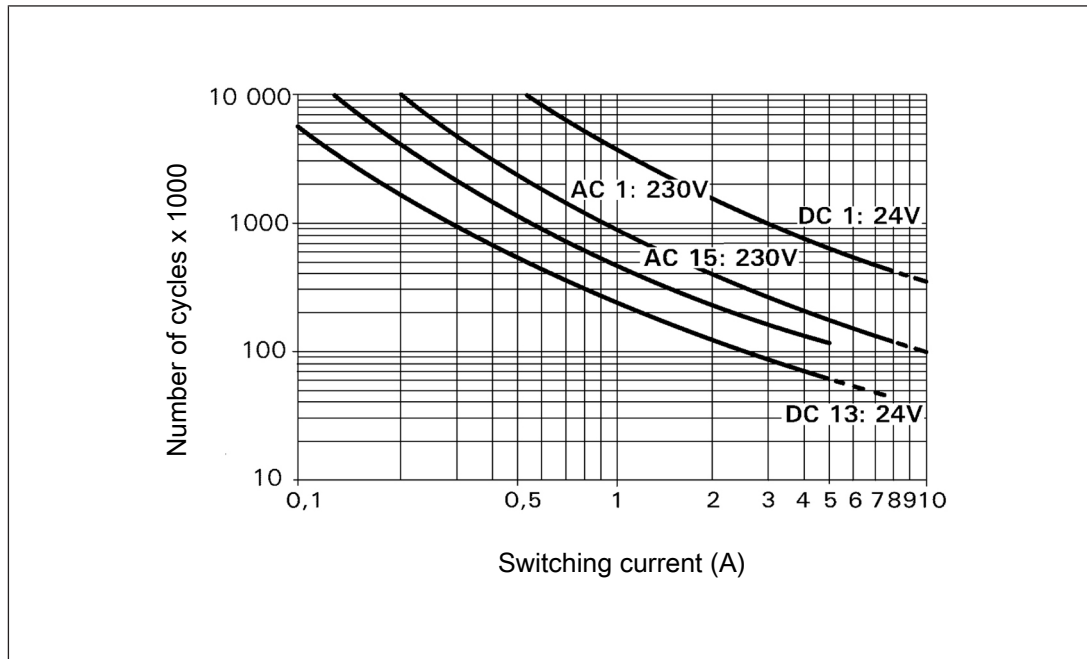

Example

- ▶ Inductive load: 0.2 A
- ▶ Utilisation category: AC15
- ▶ Contact service life: 4 000 000 cycles

Provided the application to be implemented requires fewer than 4 000 000 cycles, the PFH value (see Technical details) can be used in the calculation.

To increase the service life, sufficient spark suppression must be provided on all output contacts. With capacitive loads, any power surges that occur must be noted. With DC contactors, use flywheel diodes for spark suppression.

Order reference

| Product type | Features | Connection type | Order no. |
|--------------|---------------|-------------------------|-----------|
| PNOZ X7P C | 24 VAC/DC | Spring-loaded terminals | 787 059 |
| PNOZ X7P | 24 VAC/DC | Screw terminals | 777 059 |
| PNOZ X7P C | 110 - 120 VAC | Spring-loaded terminals | 787 053 |
| PNOZ X7P | 110 - 120 VAC | Screw terminals | 777 053 |
| PNOZ X7P C | 230 - 240 VAC | Spring-loaded terminals | 787 056 |
| PNOZ X7P | 230 - 240 VAC | Screw terminals | 777 056 |

Safety relays PNOZ X PNOZ X8P

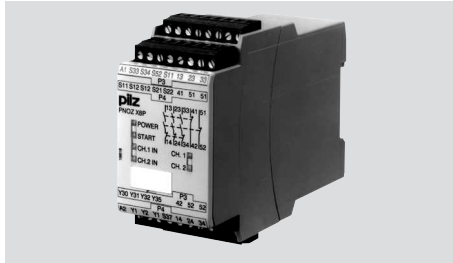

Unit features

- ▶ Positive-guided relay outputs:
 - 3 safety contacts (N/O), instantaneous
 - 2 auxiliary contacts (N/C), instantaneous
- ▶ 2 semiconductor outputs
- ▶ Connection options for:
 - E-STOP pushbuttons
 - Safety gate limit switches
 - Start button
 - Light guards and safety switches
- ▶ LED indicator for:
 - Supply voltage
 - Input state
 - Switch state of the safety contacts
 - Start circuit
- ▶ Semiconductor outputs signal:
 - Supply voltage is present
 - Switch status of the safety contacts
- ▶ Plug-in connection terminals (either spring-loaded terminal or screw terminal)
- ▶ See order reference for unit types

Safety relays PNOZ X PNOZ X8P

Block diagram/terminal configuration

Types: DC

- ▶ U_B : 24 VDC; Order no. 777760, 787760

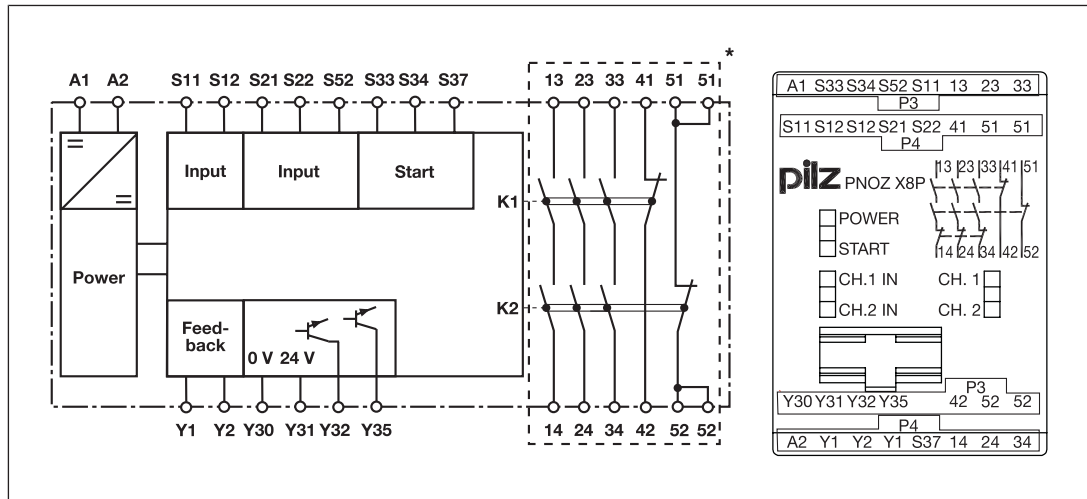

*Insulation between the non-marked area and the relay contacts: Basic insulation (over-voltage category III), Protective separation (overvoltage category II)

Safety relays PNOZ X PNOZ X8P

Types: AC

- ▶ U_B : 24 VAC; Order no. 777770, 787770
- ▶ U_B : 110 VAC; Order no. 777764, 787764
- ▶ U_B : 115 VAC; Order no. 777765
- ▶ U_B : 120 VAC; Order no. 777766, 787766
- ▶ U_B : 230 VAC; Order no. 777768, 787768

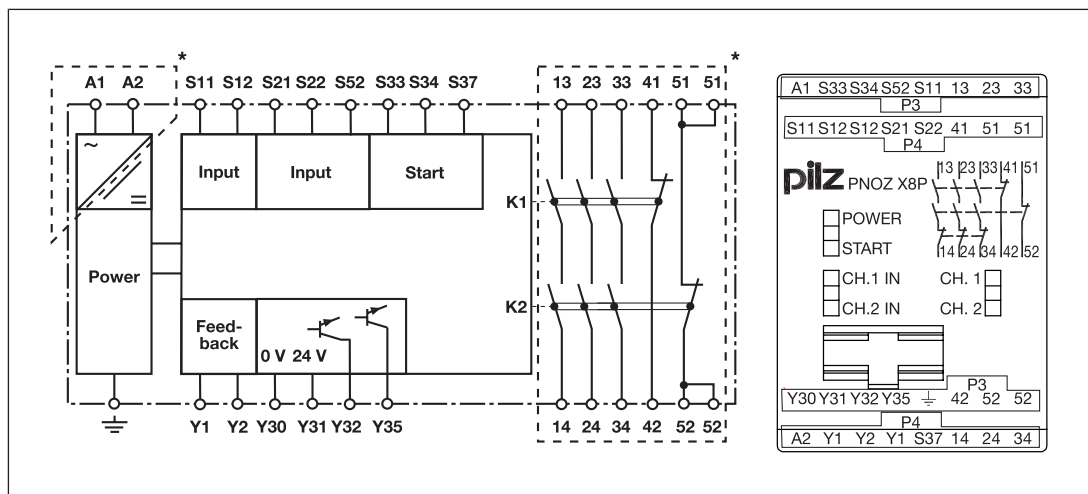

*Insulation between the non-marked area and the relay contacts: Basic insulation (over-voltage category III), Protective separation (overvoltage category II)

Function Description

The safety relay PNOZ X8P provides a safety-oriented interruption of a safety circuit. When supply voltage is supplied the "POWER" LED is lit. The unit is ready for operation when the feedback loop Y1-Y2 and the start circuit S33-S34 are closed. The "START" LED is lit.

- ▶ Input circuit is closed (e.g. E-STOP pushbutton not operated):
 - LEDs "CH1 IN" and "CH2 IN" will light.
 - The "START" LED goes out.
 - Safety contacts 13-14, 23-24 and 33-34 are closed, auxiliary contacts 41-42 and 51-52 are opened. The unit is active.
 - LEDs "CH1" and "CH2" will light.
 - A high signal is present at the semiconductor output switch state Y32.
- ▶ Input circuit is opened (e.g. E-STOP pushbutton operated):
 - LEDs "CH1 IN" and "CH2 IN" go out.
 - Safety contacts 13-14, 23-24 and 33-34 are opened redundantly, auxiliary contacts 41-42 and 51-52 are closed.
 - The LEDs "CH1" and "CH2" go out.
 - A low signal is present at the semiconductor output switch state Y32.

Safety relays PNOZ X PNOZ X8P

Semiconductor output supply voltage Y35

- ▶ A high signal is present at semi-conductor output Y35 if the supply voltage is present and the internal fuse has not blown.

Operating modes

- ▶ Single-channel operation: No redundancy in the input circuit, earth faults in the start and input circuit are detected.
- ▶ Dual-channel operation with detection of shorts across contacts: Redundant input circuit, PNOZ X8P detects
 - earth faults in the start and input circuit,
 - short circuits in the input circuit,
 - shorts across contacts in the input circuit.
- ▶ Dual-channel operation without detection of shorts across contacts: Redundant input circuit, detects PNOZ X8P
 - earth faults in the start and input circuit,
 - short circuits in the input circuit.
- ▶ Automatic start: Unit is active once the input circuit has been closed.
- ▶ Manual start: Unit is active once the input circuit and the start circuit are closed.
- ▶ Monitored start: Unit is active once
 - the input circuit is closed and then the start circuit is closed and opened again.
 - the start circuit is closed and then opened again once the input circuit is closed.
- ▶ Increase in the number of available contacts by connecting contact expander modules or external contactors/relays.

Safety relays PNOZ X PNOZ X8P

Timing diagram

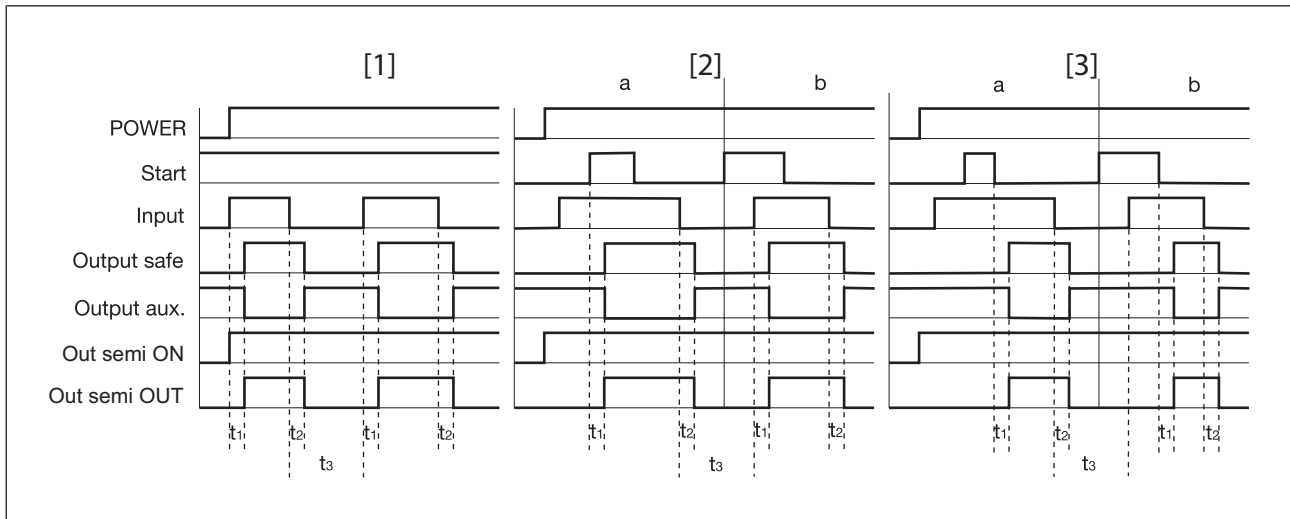

Legend

- ▶ Power: Supply voltage
- ▶ Start: Start circuit
- ▶ Input: Input circuit
- ▶ Output safe: Safety contacts
- ▶ Output aux.: Auxiliary contacts
- ▶ Out semi ON: Semiconductor output supply voltage
- ▶ Out semi OUT: Semiconductor output switch state
- ▶ [1]: Automatic start
- ▶ [2]: Manual start
- ▶ [3]: Monitored start
- ▶ a: Input circuit closes before start circuit
- ▶ b: Start circuit closes before input circuit
- ▶ t_1 : Switch-on delay
- ▶ t_2 : Delay-on de-energisation
- ▶ t_3 : Recovery time

Installation

- ▶ The unit should be installed in a control cabinet with a protection type of at least IP54.
- ▶ Use the notch on the rear of the unit to attach it to a DIN rail.
- ▶ Ensure the unit is mounted securely on a vertical DIN rail (35 mm) by using a fixing element (e.g. retaining bracket or an end angle).

Safety relays PNOZ X PNOZ X8P

Wiring

Please note:

- ▶ Information given in the "[Technical details \[188\]](#)" must be followed.
- ▶ Delivery status of units with screw terminals: Link between Y1-Y2 (feedback loop)
- ▶ Outputs 13-14, 23-24, 33-34 are safety contacts, outputs 41-42, 51-52 are auxiliary contacts (e.g. for display).
- ▶ Do **not** use auxiliary contacts 41-42, 51-52 for safety circuits!
- ▶ Do not connect undesignated terminals.
- ▶ To prevent contact welding, a fuse should be connected before the output contacts (see [Technical details \[188\]](#)).
- ▶ Calculation of the max. cable length l_{\max} in the input circuit:

$$l_{\max} = \frac{R_{l_{\max}}}{R_l / \text{km}}$$

$R_{l_{\max}}$ = max. overall cable resistance (see [Technical details \[188\]](#))

R_l / km = cable resistance/km

- ▶ Use copper wire that can withstand 60/75 °C.
- ▶ Sufficient fuse protection must be provided on all output contacts with capacitive and inductive loads.
- ▶ Do not switch low currents using contacts that have been used previously with high currents.
- ▶ When connecting magnetically operated, reed proximity switches, ensure that the max. peak inrush current (on the input circuit) does not overload the proximity switch.
- ▶ On 24 VDC devices:
The power supply must comply with the regulations for extra low voltages with protective electrical separation (SELV, PELV) in accordance with VDE 0100, Part 410.
- ▶ Ensure the wiring and EMC requirements of IEC 60204-1 are met.

Important for detection of shorts across contacts:

As this function for detecting shorts across contacts is not failsafe, it is tested by Pilz during the final control check. If there is a danger of exceeding the cable runs, we recommend the following test after the installation of the device:

1. Unit ready for operation (output contacts closed)
2. Short circuit the test terminals S12, S22 for detecting shorts across the inputs.
3. The unit's fuse must be triggered and the output contacts must open. Cable lengths in the scale of the maximum length can delay the fuse triggering for up to 2 minutes.
4. Reset the fuse: remove the short circuit and switch off the supply voltage for approx. 1 minute.

Safety relays PNOZ X PNOZ X8P

Preparing for operation

| Supply voltage | AC | DC |
|--|----------------|---------------------------------------|
| | | |
| Input circuit | Single-channel | Dual-channel |
| E-STOP without detection of shorts across contacts | | |
| E-STOP with detection of shorts across contacts | / | |
| Safety gate without detection of shorts across contacts | | <p>Simultaneity S1 and S2: 150 ms</p> |
| Safety gate with detection of shorts across contacts | / | |
| Light guard or safety switch, detection of shorts across contacts via ESPE | / | |

Safety relays PNOZ X PNOZ X8P



| | E-STOP/safety gate wiring (single-channel, dual-channel without detection of shorts across contacts) | E-STOP/safety gate wiring (dual-channel with detection of shorts across contacts) |
|--|---|---|
| Start circuit | | |
| Automatic start | | |
| Automatic start with start-up test | | |
| Manual start | | |
| Monitored start | | |
| Feedback loop | without feedback loop monitor- ing | with feedback loop monitoring |
| Link or contacts from external contactors | | |

Safety relays PNOZ X PNOZ X8P

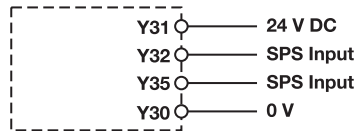
Semiconductor output



Legend

- ▶ S1: E-STOP pushbuttons
- ▶ S3: Start button
- ▶ ↑↑: Switch operated
- ▶ : Gate open
- ▶ : Gate closed

Dimensions in mm

* With spring-loaded terminals

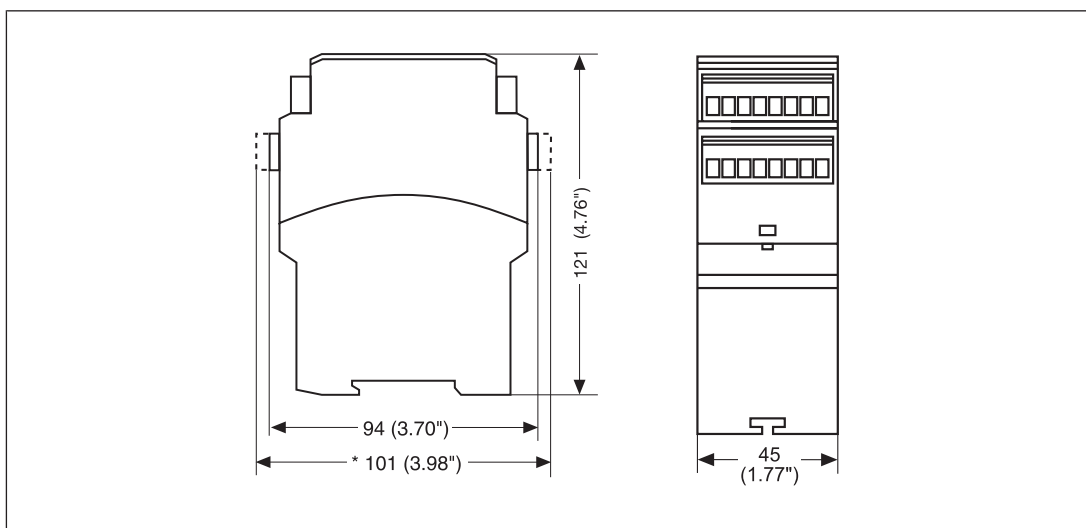

Safety relays PNOZ X PNOZ X8P

Technical details Order no. 777760-777765

| General | 777760 | 777764 | 777765 |
|--------------------------------------|--|--|--|
| Approvals | CCC, CE, EAC (Eurasian), TÜV, cULus Listed | CCC, CE, EAC (Eurasian), TÜV, cULus Listed | CCC, CE, EAC (Eurasian), TÜV, cULus Listed |
| Electrical data | 777760 | 777764 | 777765 |
| Supply voltage | | | |
| Voltage | 24 V | 110 V | 115 V |
| Kind | DC | AC | AC |
| Voltage tolerance | -15 %/+10 % | -15 %/+10 % | -15 %/+10 % |
| Output of external power supply (AC) | – | 6,5 VA | 6,5 VA |
| Output of external power supply (DC) | 2,5 W | – | – |
| Frequency range AC | – | 50 - 60 Hz | 50 - 60 Hz |
| Residual ripple DC | 160 % | – | – |
| Duty cycle | 100 % | 100 % | 100 % |
| Max. inrush current impulse | | | |
| Current pulse, A1 | 10 A | – | – |
| Pulse duration, A1 | 0,5 ms | – | – |
| Inputs | 777760 | 777764 | 777765 |
| Number | 2 | 2 | 2 |
| Voltage at | | | |
| Input circuit DC | 24 V | 24 V | 24 V |
| Start circuit DC | 24 V | 24 V | 24 V |
| Feedback loop DC | 24 V | 24 V | 24 V |
| Current at | | | |
| Input circuit DC | 45 mA | 40 mA | 40 mA |
| Start circuit DC | 50 mA | 60 mA | 60 mA |
| Feedback loop DC | 50 mA | 60 mA | 60 mA |
| Min. input resistance at power-on | 89 Ohm | 89 Ohm | 89 Ohm |

Safety relays PNOZ X PNOZ X8P

| Inputs | 777760 | 777764 | 777765 |
|---|---------------|---------------|---------------|
| Max. overall cable resistance R _{lmax} | | | |
| Single-channel at UB DC | 100 Ohm | – | – |
| Single-channel at UB AC | – | 100 Ohm | 100 Ohm |
| Dual-channel without detection of shorts across contacts at UB DC | 200 Ohm | – | – |
| Dual-channel without detection of shorts across contacts at UB AC | – | 200 Ohm | 200 Ohm |
| Dual-channel with detection of shorts across contacts at UB DC | 16 Ohm | – | – |
| Dual-channel with detection of shorts across contacts at UB AC | – | 28 Ohm | 28 Ohm |
| Semiconductor outputs | 777760 | 777764 | 777765 |
| Number | 2 | 2 | 2 |
| Voltage | 24 V | 24 V | 24 V |
| Current | 50 mA | 50 mA | 50 mA |
| External supply voltage | 24 V | 24 V | 24 V |
| Voltage tolerance | -20 %/+20 % | -20 %/+20 % | -20 %/+20 % |
| Relay outputs | 777760 | 777764 | 777765 |
| Number of output contacts | | | |
| Safety contacts (N/O), instantaneous | 3 | 3 | 3 |
| Auxiliary contacts (N/C) | 2 | 2 | 2 |
| Max. short circuit current I _K | 1 kA | 1 kA | 1 kA |
| Utilisation category | | | |
| In accordance with the standard | EN 60947-4-1 | EN 60947-4-1 | EN 60947-4-1 |

Safety relays PNOZ X PNOZ X8P

| Relay outputs | 777760 | 777764 | 777765 |
|--|-------------------|-------------------|-------------------|
| Utilisation category of safety contacts | | | |
| AC1 at | 240 V | 240 V | 240 V |
| Min. current | 0,01 A | 0,01 A | 0,01 A |
| Max. current | 8 A | 8 A | 8 A |
| Max. power | 2000 VA | 2000 VA | 2000 VA |
| DC1 at | 24 V | 24 V | 24 V |
| Min. current | 0,01 A | 0,01 A | 0,01 A |
| Max. current | 8 A | 8 A | 8 A |
| Max. power | 200 W | 200 W | 200 W |
| Utilisation category of auxiliary contacts | | | |
| AC1 at | 240 V | 240 V | 240 V |
| Min. current | 0,01 A | 0,01 A | 0,01 A |
| Max. current | 8 A | 8 A | 8 A |
| Max. power | 2000 VA | 2000 VA | 2000 VA |
| DC1 at | 24 V | 24 V | 24 V |
| Min. current | 0,01 A | 0,01 A | 0,01 A |
| Max. current | 8 A | 8 A | 8 A |
| Max. power | 200 W | 200 W | 200 W |
| Utilisation category | | | |
| In accordance with the standard | EN 60947-5-1 | EN 60947-5-1 | EN 60947-5-1 |
| Utilisation category of safety contacts | | | |
| AC15 at | 230 V | 230 V | 230 V |
| Max. current | 5 A | 5 A | 5 A |
| DC13 (6 cycles/min) at | 24 V | 24 V | 24 V |
| Max. current | 7 A | 7 A | 7 A |
| Utilisation category of auxiliary contacts | | | |
| AC15 at | 230 V | 230 V | 230 V |
| Max. current | 5 A | 5 A | 5 A |
| DC13 (6 cycles/min) at | 24 V | 24 V | 24 V |
| Max. current | 7 A | 7 A | 7 A |
| Utilisation category in accordance with UL | | | |
| Voltage | 240 V AC G. P. | 240 V AC G. P. | 240 V AC G. P. |
| With current | 8 A | 8 A | 8 A |
| Voltage | 24 V DC Resistive | 24 V DC Resistive | 24 V DC Resistive |
| With current | 5 A | 5 A | 5 A |
| Pilot Duty | B300, R300 | B300, R300 | B300, R300 |

Safety relays PNOZ X PNOZ X8P

| Relay outputs | 777760 | 777764 | 777765 |
|--|--------------------------------|--------------------------------|--------------------------------|
| External contact fuse protection, safety contacts | | | |
| In accordance with the standard | EN 60947-5-1 | EN 60947-5-1 | EN 60947-5-1 |
| Max. melting integral | 240 A ² s | 240 A ² s | 240 A ² s |
| Blow-out fuse, quick | 10 A | 10 A | 10 A |
| Blow-out fuse, slow | 6 A | 6 A | 6 A |
| Blow-out fuse, gG | 10 A | 10 A | 10 A |
| Circuit breaker 24V AC/DC, characteristic B/C | 6 A | 6 A | 6 A |
| External contact fuse protection, auxiliary contacts | | | |
| Max. melting integral | 240 A ² s | 240 A ² s | 240 A ² s |
| Blow-out fuse, quick | 10 A | 10 A | 10 A |
| Blow-out fuse, slow | 6 A | 6 A | 6 A |
| Blow-out fuse, gG | 10 A | 10 A | 10 A |
| Circuit breaker 24 V AC/DC, characteristic B/C | 6 A | 6 A | 6 A |
| Contact material | AgSnO ₂ + 0,2 µm Au | AgSnO ₂ + 0,2 µm Au | AgSnO ₂ + 0,2 µm Au |
| Conventional thermal current while loading several contacts | 777760 | 777764 | 777765 |
| I _{th} per contact at UB AC; AC1: 240 V, DC1: 24 V | | | |
| Conv. therm. current with 1 contact | – | 8 A | 8 A |
| Conv. therm. current with 2 contacts | – | 7,3 A | 7,3 A |
| Conv. therm. current with 3 contacts | – | 6 A | 6 A |
| I _{th} per contact at UB DC; AC1: 240 V, DC1: 24 V | | | |
| Conv. therm. current with 1 contact | 8 A | – | – |
| Conv. therm. current with 2 contacts | 8 A | – | – |
| Conv. therm. current with 3 contacts | 7 A | – | – |

Safety relays PNOZ X PNOZ X8P

| Times | 777760 | 777764 | 777765 |
|--|--|--|--|
| Switch-on delay | | | |
| With automatic start typ. | 160 ms | 175 ms | 175 ms |
| With automatic start max. | 200 ms | 220 ms | 220 ms |
| With automatic start after power on typ. | 185 ms | 200 ms | 200 ms |
| With automatic start after power on max. | 220 ms | 250 ms | 250 ms |
| With manual start typ. | 190 ms | 190 ms | 190 ms |
| With manual start max. | 250 ms | 250 ms | 250 ms |
| With monitored start typ. | 130 ms | 130 ms | 130 ms |
| With monitored start max. | 180 ms | 180 ms | 180 ms |
| Delay-on de-energisation | | | |
| With E-STOP typ. | 15 ms | 15 ms | 15 ms |
| With E-STOP max. | 30 ms | 30 ms | 30 ms |
| With power failure typ. | 100 ms | 160 ms | 160 ms |
| With power failure max. | 200 ms | 220 ms | 220 ms |
| Recovery time at max. switching frequency 1/s | | | |
| After E-STOP | 50 ms | 50 ms | 50 ms |
| After power failure | 180 ms | 250 ms | 250 ms |
| Min. start pulse duration with a monitored start | | | |
| | 30 ms | 30 ms | 30 ms |
| Supply interruption before de-energisation | | | |
| | 35 ms | 35 ms | 35 ms |
| Environmental data | 777760 | 777764 | 777765 |
| Climatic suitability | EN 60068-2-78 | EN 60068-2-78 | EN 60068-2-78 |
| Ambient temperature | | | |
| Temperature range | -10 - 55 °C | -10 - 55 °C | -10 - 55 °C |
| Storage temperature | | | |
| Temperature range | -40 - 85 °C | -40 - 85 °C | -40 - 85 °C |
| Climatic suitability | | | |
| Humidity | 93 % r. h. at 40 °C | 93 % r. h. at 40 °C | 93 % r. h. at 40 °C |
| Condensation during operation | | | |
| | Not permitted | Not permitted | Not permitted |
| EMC | | | |
| | EN 60947-5-1, EN 61000-6-2, EN 61326-3-1 | EN 60947-5-1, EN 61000-6-2, EN 61326-3-1 | EN 60947-5-1, EN 61000-6-2, EN 61326-3-1 |

Safety relays PNOZ X PNOZ X8P

| Environmental data | 777760 | 777764 | 777765 |
|---|--|--|--|
| Vibration | | | |
| In accordance with the standard | EN 60068-2-6 | EN 60068-2-6 | EN 60068-2-6 |
| Frequency | 10 - 55 Hz | 10 - 55 Hz | 10 - 55 Hz |
| Amplitude | 0,35 mm | 0,35 mm | 0,35 mm |
| Airgap creepage | | | |
| In accordance with the standard | EN 60947-1 | EN 60947-1 | EN 60947-1 |
| Overvoltage category | III / II | III / II | III / II |
| Pollution degree | 2 | 2 | 2 |
| Rated insulation voltage | 250 V | 250 V | 250 V |
| Rated impulse withstand voltage | 4 kV | 4 kV | 4 kV |
| Protection type | | | |
| Mounting area (e.g. control cabinet) | IP54 | IP54 | IP54 |
| Housing | IP40 | IP40 | IP40 |
| Terminals | IP20 | IP20 | IP20 |
| Mechanical data | 777760 | 777764 | 777765 |
| Mounting position | Any | Any | Any |
| Mechanical life | 10,000,000 cycles | 10,000,000 cycles | 10,000,000 cycles |
| Material | | | |
| Bottom | PPO UL 94 V0 | PPO UL 94 V0 | PPO UL 94 V0 |
| Front | ABS UL 94 V0 | ABS UL 94 V0 | ABS UL 94 V0 |
| Top | PPO UL 94 V0 | PPO UL 94 V0 | PPO UL 94 V0 |
| Connection type | Screw terminal | Screw terminal | Screw terminal |
| Mounting type | plug-in | plug-in | plug-in |
| Conductor cross section with screw terminals | | | |
| 1 core flexible | 0,25 - 2,5 mm ² , 24 - 12 AWG | 0,25 - 2,5 mm ² , 24 - 12 AWG | 0,25 - 2,5 mm ² , 24 - 12 AWG |
| 2 core with the same cross section, flexible with crimp connectors, no plastic sleeve | 0,25 - 1 mm ² , 24 - 16 AWG | 0,25 - 1 mm ² , 24 - 16 AWG | 0,25 - 1 mm ² , 24 - 16 AWG |
| 2 core with the same cross section, flexible without crimp connectors or with TWIN crimp connectors | 0,2 - 1,5 mm ² , 24 - 16 AWG | 0,2 - 1,5 mm ² , 24 - 16 AWG | 0,2 - 1,5 mm ² , 24 - 16 AWG |
| Torque setting with screw terminals | 0,5 Nm | 0,5 Nm | 0,5 Nm |

Safety relays PNOZ X PNOZ X8P

| Mechanical data | 777760 | 777764 | 777765 |
|-----------------|--------|--------|--------|
| Dimensions | | | |
| Height | 94 mm | 94 mm | 94 mm |
| Width | 45 mm | 45 mm | 45 mm |
| Depth | 121 mm | 121 mm | 121 mm |
| Weight | 315 g | 415 g | 415 g |

Where standards are undated, the 2014-07 latest editions shall apply.

Technical details Order no. 777766-777770

| General | 777766 | 777768 | 777770 |
|--------------------------------------|--|--|--|
| Approvals | CCC, CE, EAC (Eurasian), TÜV, cULus Listed | CCC, CE, EAC (Eurasian), TÜV, cULus Listed | CCC, CE, EAC (Eurasian), TÜV, cULus Listed |
| Electrical data | 777766 | 777768 | 777770 |
| Supply voltage | | | |
| Voltage | 120 V | 230 V | 24 V |
| Kind | AC | AC | AC |
| Voltage tolerance | -15 %/+10 % | -15 %/+10 % | -15 %/+10 % |
| Output of external power supply (AC) | 6,5 VA | 6,5 VA | 6,5 VA |
| Frequency range AC | 50 - 60 Hz | 50 - 60 Hz | 50 - 60 Hz |
| Duty cycle | 100 % | 100 % | 100 % |
| Inputs | 777766 | 777768 | 777770 |
| Number | 2 | 2 | 2 |
| Voltage at | | | |
| Input circuit DC | 24 V | 24 V | 24 V |
| Start circuit DC | 24 V | 24 V | 24 V |
| Feedback loop DC | 24 V | 24 V | 24 V |
| Current at | | | |
| Input circuit DC | 40 mA | 40 mA | 40 mA |
| Start circuit DC | 60 mA | 60 mA | 60 mA |
| Feedback loop DC | 60 mA | 60 mA | 60 mA |
| Min. input resistance at power-on | 89 Ohm | 89 Ohm | 89 Ohm |

Safety relays PNOZ X PNOZ X8P

| Inputs | 777766 | 777768 | 777770 |
|---|---------------------|---------------------|---------------------|
| Max. overall cable resistance R _{lmax} | | | |
| Single-channel at UB AC | 100 Ohm | 100 Ohm | 100 Ohm |
| Dual-channel without detection of shorts across contacts at UB AC | 200 Ohm | 200 Ohm | 200 Ohm |
| Dual-channel with detection of shorts across contacts at UB AC | 28 Ohm | 28 Ohm | 28 Ohm |
| Semiconductor outputs | 777766 | 777768 | 777770 |
| Number | 2 | 2 | 2 |
| Voltage | 24 V | 24 V | 24 V |
| Current | 50 mA | 50 mA | 50 mA |
| External supply voltage | 24 V | 24 V | 24 V |
| Voltage tolerance | -20 %/+20 % | -20 %/+20 % | -20 %/+20 % |
| Relay outputs | 777766 | 777768 | 777770 |
| Number of output contacts | | | |
| Safety contacts (N/O), instantaneous | 3 | 3 | 3 |
| Auxiliary contacts (N/C) | 2 | 2 | 2 |
| Max. short circuit current I _K | | | |
| | 1 kA | 1 kA | 1 kA |
| Utilisation category | | | |
| In accordance with the standard | EN 60947-4-1 | EN 60947-4-1 | EN 60947-4-1 |
| Utilisation category of safety contacts | | | |
| AC1 at | 240 V | 240 V | 240 V |
| Min. current | 0,01 A | 0,01 A | 0,01 A |
| Max. current | 8 A | 8 A | 8 A |
| Max. power | 2000 VA | 2000 VA | 2000 VA |
| DC1 at | 24 V | 24 V | 24 V |
| Min. current | 0,01 A | 0,01 A | 0,01 A |
| Max. current | 8 A | 8 A | 8 A |
| Max. power | 200 W | 200 W | 200 W |

Safety relays PNOZ X PNOZ X8P

| Relay outputs | 777766 | 777768 | 777770 |
|---|----------------------|----------------------|----------------------|
| Utilisation category of auxiliary contacts | | | |
| AC1 at | 240 V | 240 V | 240 V |
| Min. current | 0,01 A | 0,01 A | 0,01 A |
| Max. current | 8 A | 8 A | 8 A |
| Max. power | 2000 VA | 2000 VA | 2000 VA |
| DC1 at | 24 V | 24 V | 24 V |
| Min. current | 0,01 A | 0,01 A | 0,01 A |
| Max. current | 8 A | 8 A | 8 A |
| Max. power | 200 W | 200 W | 200 W |
| Utilisation category | | | |
| In accordance with the standard | EN 60947-5-1 | EN 60947-5-1 | EN 60947-5-1 |
| Utilisation category of safety contacts | | | |
| AC15 at | 230 V | 230 V | 230 V |
| Max. current | 5 A | 5 A | 5 A |
| DC13 (6 cycles/min) at | 24 V | 24 V | 24 V |
| Max. current | 7 A | 7 A | 7 A |
| Utilisation category of auxiliary contacts | | | |
| AC15 at | 230 V | 230 V | 230 V |
| Max. current | 5 A | 5 A | 5 A |
| DC13 (6 cycles/min) at | 24 V | 24 V | 24 V |
| Max. current | 7 A | 7 A | 7 A |
| Utilisation category in accordance with UL | | | |
| Voltage | 240 V AC G. P. | 240 V AC G. P. | 240 V AC G. P. |
| With current | 8 A | 8 A | 8 A |
| Voltage | 24 V DC Resistive | 24 V DC Resistive | 24 V DC Resistive |
| With current | 5 A | 5 A | 5 A |
| Pilot Duty | B300, R300 | B300, R300 | B300, R300 |
| External contact fuse protection, safety contacts | | | |
| In accordance with the standard | EN 60947-5-1 | EN 60947-5-1 | EN 60947-5-1 |
| Max. melting integral | 240 A ² s | 240 A ² s | 240 A ² s |
| Blow-out fuse, quick | 10 A | 10 A | 10 A |
| Blow-out fuse, slow | 6 A | 6 A | 6 A |
| Blow-out fuse, gG | 10 A | 10 A | 10 A |
| Circuit breaker 24V AC/DC, characteristic B/C | 6 A | 6 A | 6 A |

Safety relays PNOZ X PNOZ X8P

| Relay outputs | 777766 | 777768 | 777770 |
|--|--------------------------------|--------------------------------|--------------------------------|
| External contact fuse protection, auxiliary contacts | | | |
| Max. melting integral | 240 A ² s | 240 A ² s | 240 A ² s |
| Blow-out fuse, quick | 10 A | 10 A | 10 A |
| Blow-out fuse, slow | 6 A | 6 A | 6 A |
| Blow-out fuse, gG | 10 A | 10 A | 10 A |
| Circuit breaker 24 V AC/DC, characteristic B/C | 6 A | 6 A | 6 A |
| Contact material | AgSnO ₂ + 0,2 µm Au | AgSnO ₂ + 0,2 µm Au | AgSnO ₂ + 0,2 µm Au |
| Conventional thermal current while loading several contacts | 777766 | 777768 | 777770 |
| I _{th} per contact at UB AC; AC1: 240 V, DC1: 24 V | | | |
| Conv. therm. current with 1 contact | 8 A | 8 A | 8 A |
| Conv. therm. current with 2 contacts | 7,3 A | 7,3 A | 7,3 A |
| Conv. therm. current with 3 contacts | 6 A | 6 A | 6 A |
| Times | 777766 | 777768 | 777770 |
| Switch-on delay | | | |
| With automatic start typ. | 175 ms | 175 ms | 175 ms |
| With automatic start max. | 220 ms | 220 ms | 220 ms |
| With automatic start after power on typ. | 200 ms | 200 ms | 200 ms |
| With automatic start after power on max. | 250 ms | 250 ms | 250 ms |
| With manual start typ. | 190 ms | 190 ms | 190 ms |
| With manual start max. | 250 ms | 250 ms | 250 ms |
| With monitored start typ. | 130 ms | 130 ms | 130 ms |
| With monitored start max. | 180 ms | 180 ms | 180 ms |
| Delay-on de-energisation | | | |
| With E-STOP typ. | 15 ms | 15 ms | 15 ms |
| With E-STOP max. | 30 ms | 30 ms | 30 ms |
| With power failure typ. | 160 ms | 160 ms | 160 ms |
| With power failure max. | 220 ms | 220 ms | 220 ms |

Safety relays PNOZ X PNOZ X8P

| Times | 777766 | 777768 | 777770 |
|--|--|--|--|
| Recovery time at max. switching frequency 1/s | | | |
| After E-STOP | 50 ms | 50 ms | 50 ms |
| After power failure | 250 ms | 250 ms | 250 ms |
| Min. start pulse duration with a monitored start | 30 ms | 30 ms | 30 ms |
| Supply interruption before de-energisation | 35 ms | 35 ms | 35 ms |
| Environmental data | 777766 | 777768 | 777770 |
| Climatic suitability | EN 60068-2-78 | EN 60068-2-78 | EN 60068-2-78 |
| Ambient temperature | | | |
| Temperature range | -10 - 55 °C | -10 - 55 °C | -10 - 55 °C |
| Storage temperature | | | |
| Temperature range | -40 - 85 °C | -40 - 85 °C | -40 - 85 °C |
| Climatic suitability | | | |
| Humidity | 93 % r. h. at 40 °C | 93 % r. h. at 40 °C | 93 % r. h. at 40 °C |
| Condensation during operation | Not permitted | Not permitted | Not permitted |
| EMC | EN 60947-5-1, EN 61000-6-2, EN 61326-3-1 | EN 60947-5-1, EN 61000-6-2, EN 61326-3-1 | EN 60947-5-1, EN 61000-6-2, EN 61326-3-1 |
| Vibration | | | |
| In accordance with the standard | EN 60068-2-6 | EN 60068-2-6 | EN 60068-2-6 |
| Frequency | 10 - 55 Hz | 10 - 55 Hz | 10 - 55 Hz |
| Amplitude | 0,35 mm | 0,35 mm | 0,35 mm |
| Airgap creepage | | | |
| In accordance with the standard | EN 60947-1 | EN 60947-1 | EN 60947-1 |
| Overvoltage category | III / II | III / II | III / II |
| Pollution degree | 2 | 2 | 2 |
| Rated insulation voltage | 250 V | 250 V | 250 V |
| Rated impulse withstand voltage | 4 kV | 4 kV | 4 kV |
| Protection type | | | |
| Mounting area (e.g. control cabinet) | IP54 | IP54 | IP54 |
| Housing | IP40 | IP40 | IP40 |
| Terminals | IP20 | IP20 | IP20 |
| Mechanical data | 777766 | 777768 | 777770 |
| Mounting position | Any | Any | Any |
| Mechanical life | 10,000,000 cycles | 10,000,000 cycles | 10,000,000 cycles |

Safety relays PNOZ X PNOZ X8P

| Mechanical data | 777766 | 777768 | 777770 |
|---|--|--|--|
| Material | | | |
| Bottom | PPO UL 94 V0 | PPO UL 94 V0 | PPO UL 94 V0 |
| Front | ABS UL 94 V0 | ABS UL 94 V0 | ABS UL 94 V0 |
| Top | PPO UL 94 V0 | PPO UL 94 V0 | PPO UL 94 V0 |
| Connection type | Screw terminal | Screw terminal | Screw terminal |
| Mounting type | plug-in | plug-in | plug-in |
| Conductor cross section with screw terminals | | | |
| 1 core flexible | 0,25 - 2,5 mm ² , 24 - 12 AWG | 0,25 - 2,5 mm ² , 24 - 12 AWG | 0,25 - 2,5 mm ² , 24 - 12 AWG |
| 2 core with the same cross section, flexible with crimp connectors, no plastic sleeve | 0,25 - 1 mm ² , 24 - 16 AWG | 0,25 - 1 mm ² , 24 - 16 AWG | 0,25 - 1 mm ² , 24 - 16 AWG |
| 2 core with the same cross section, flexible without crimp connectors or with TWIN crimp connectors | 0,2 - 1,5 mm ² , 24 - 16 AWG | 0,2 - 1,5 mm ² , 24 - 16 AWG | 0,2 - 1,5 mm ² , 24 - 16 AWG |
| Torque setting with screw terminals | 0,5 Nm | 0,5 Nm | 0,5 Nm |
| Dimensions | | | |
| Height | 94 mm | 94 mm | 94 mm |
| Width | 45 mm | 45 mm | 45 mm |
| Depth | 121 mm | 121 mm | 121 mm |
| Weight | 415 g | 415 g | 415 g |

Where standards are undated, the 2014-07 latest editions shall apply.

Safety relays PNOZ X PNOZ X8P

Technical details Order no. 787760-787766

| General | 787760 | 787764 | 787766 |
|--------------------------------------|--|--|--|
| Approvals | CCC, CE, EAC (Eurasian), TÜV, cULus Listed | CCC, CE, EAC (Eurasian), TÜV, cULus Listed | CCC, CE, EAC (Eurasian), TÜV, cULus Listed |
| Electrical data | 787760 | 787764 | 787766 |
| Supply voltage | | | |
| Voltage | 24 V | 110 V | 120 V |
| Kind | DC | AC | AC |
| Voltage tolerance | -15 %/+10 % | -15 %/+10 % | -15 %/+10 % |
| Output of external power supply (AC) | – | 6,5 VA | 6,5 VA |
| Output of external power supply (DC) | 2,5 W | – | – |
| Frequency range AC | – | 50 - 60 Hz | 50 - 60 Hz |
| Residual ripple DC | 160 % | – | – |
| Duty cycle | 100 % | 100 % | 100 % |
| Max. inrush current impulse | | | |
| Current pulse, A1 | 10 A | – | – |
| Pulse duration, A1 | 0,5 ms | – | – |
| Inputs | 787760 | 787764 | 787766 |
| Number | 2 | 2 | 2 |
| Voltage at | | | |
| Input circuit DC | 24 V | 24 V | 24 V |
| Start circuit DC | 24 V | 24 V | 24 V |
| Feedback loop DC | 24 V | 24 V | 24 V |
| Current at | | | |
| Input circuit DC | 45 mA | 40 mA | 40 mA |
| Start circuit DC | 50 mA | 60 mA | 60 mA |
| Feedback loop DC | 50 mA | 60 mA | 60 mA |
| Min. input resistance at power-on | 89 Ohm | 89 Ohm | 89 Ohm |

Safety relays PNOZ X PNOZ X8P

| Inputs | 787760 | 787764 | 787766 |
|---|---------------|---------------|---------------|
| Max. overall cable resistance R _{lmax} | | | |
| Single-channel at UB DC | 100 Ohm | – | – |
| Single-channel at UB AC | – | 100 Ohm | 100 Ohm |
| Dual-channel without detection of shorts across contacts at UB DC | 200 Ohm | – | – |
| Dual-channel without detection of shorts across contacts at UB AC | – | 200 Ohm | 200 Ohm |
| Dual-channel with detection of shorts across contacts at UB DC | 16 Ohm | – | – |
| Dual-channel with detection of shorts across contacts at UB AC | – | 28 Ohm | 28 Ohm |
| Semiconductor outputs | 787760 | 787764 | 787766 |
| Number | 2 | 2 | 2 |
| Voltage | 24 V | 24 V | 24 V |
| Current | 50 mA | 50 mA | 50 mA |
| External supply voltage | 24 V | 24 V | 24 V |
| Voltage tolerance | -20 %/+20 % | -20 %/+20 % | -20 %/+20 % |
| Relay outputs | 787760 | 787764 | 787766 |
| Number of output contacts | | | |
| Safety contacts (N/O), instantaneous | 3 | 3 | 3 |
| Auxiliary contacts (N/C) | 2 | 2 | 2 |
| Max. short circuit current I _K | 1 kA | 1 kA | 1 kA |
| Utilisation category | | | |
| In accordance with the standard | EN 60947-4-1 | EN 60947-4-1 | EN 60947-4-1 |

Safety relays PNOZ X PNOZ X8P

| Relay outputs | 787760 | 787764 | 787766 |
|--|-------------------|-------------------|-------------------|
| Utilisation category of safety contacts | | | |
| AC1 at | 240 V | 240 V | 240 V |
| Min. current | 0,01 A | 0,01 A | 0,01 A |
| Max. current | 8 A | 8 A | 8 A |
| Max. power | 2000 VA | 2000 VA | 2000 VA |
| DC1 at | 24 V | 24 V | 24 V |
| Min. current | 0,01 A | 0,01 A | 0,01 A |
| Max. current | 8 A | 8 A | 8 A |
| Max. power | 200 W | 200 W | 200 W |
| Utilisation category of auxiliary contacts | | | |
| AC1 at | 240 V | 240 V | 240 V |
| Min. current | 0,01 A | 0,01 A | 0,01 A |
| Max. current | 8 A | 8 A | 8 A |
| Max. power | 2000 VA | 2000 VA | 2000 VA |
| DC1 at | 24 V | 24 V | 24 V |
| Min. current | 0,01 A | 0,01 A | 0,01 A |
| Max. current | 8 A | 8 A | 8 A |
| Max. power | 200 W | 200 W | 200 W |
| Utilisation category | | | |
| In accordance with the standard | EN 60947-5-1 | EN 60947-5-1 | EN 60947-5-1 |
| Utilisation category of safety contacts | | | |
| AC15 at | 230 V | 230 V | 230 V |
| Max. current | 5 A | 5 A | 5 A |
| DC13 (6 cycles/min) at | 24 V | 24 V | 24 V |
| Max. current | 7 A | 7 A | 7 A |
| Utilisation category of auxiliary contacts | | | |
| AC15 at | 230 V | 230 V | 230 V |
| Max. current | 5 A | 5 A | 5 A |
| DC13 (6 cycles/min) at | 24 V | 24 V | 24 V |
| Max. current | 7 A | 7 A | 7 A |
| Utilisation category in accordance with UL | | | |
| Voltage | 240 V AC G. P. | 240 V AC G. P. | 240 V AC G. P. |
| With current | 8 A | 8 A | 8 A |
| Voltage | 24 V DC Resistive | 24 V DC Resistive | 24 V DC Resistive |
| With current | 5 A | 5 A | 5 A |
| Pilot Duty | B300, R300 | B300, R300 | B300, R300 |

Safety relays PNOZ X PNOZ X8P

| Relay outputs | 787760 | 787764 | 787766 |
|--|--------------------------------|--------------------------------|--------------------------------|
| External contact fuse protection, safety contacts | | | |
| In accordance with the standard | EN 60947-5-1 | EN 60947-5-1 | EN 60947-5-1 |
| Max. melting integral | 240 A ² s | 240 A ² s | 240 A ² s |
| Blow-out fuse, quick | 10 A | 10 A | 10 A |
| Blow-out fuse, slow | 6 A | 6 A | 6 A |
| Blow-out fuse, gG | 10 A | 10 A | 10 A |
| Circuit breaker 24V AC/DC, characteristic B/C | 6 A | 6 A | 6 A |
| External contact fuse protection, auxiliary contacts | | | |
| Max. melting integral | 240 A ² s | 240 A ² s | 240 A ² s |
| Blow-out fuse, quick | 10 A | 10 A | 10 A |
| Blow-out fuse, slow | 6 A | 6 A | 6 A |
| Blow-out fuse, gG | 10 A | 10 A | 10 A |
| Circuit breaker 24 V AC/DC, characteristic B/C | 6 A | 6 A | 6 A |
| Contact material | AgSnO ₂ + 0,2 µm Au | AgSnO ₂ + 0,2 µm Au | AgSnO ₂ + 0,2 µm Au |
| Conventional thermal current while loading several contacts | 787760 | 787764 | 787766 |
| I _{th} per contact at UB AC; AC1: 240 V, DC1: 24 V | | | |
| Conv. therm. current with 1 contact | – | 8 A | 8 A |
| Conv. therm. current with 2 contacts | – | 7,3 A | 7,3 A |
| Conv. therm. current with 3 contacts | – | 6 A | 6 A |
| I _{th} per contact at UB DC; AC1: 240 V, DC1: 24 V | | | |
| Conv. therm. current with 1 contact | 8 A | – | – |
| Conv. therm. current with 2 contacts | 8 A | – | – |
| Conv. therm. current with 3 contacts | 7 A | – | – |

Safety relays PNOZ X PNOZ X8P

| Times | 787760 | 787764 | 787766 |
|---|--|--|--|
| Switch-on delay | | | |
| With automatic start typ. | 160 ms | 175 ms | 175 ms |
| With automatic start max. | 200 ms | 220 ms | 220 ms |
| With automatic start after power on typ. | 185 ms | 200 ms | 200 ms |
| With automatic start after power on max. | 220 ms | 250 ms | 250 ms |
| With manual start typ. | 190 ms | 190 ms | 190 ms |
| With manual start max. | 250 ms | 250 ms | 250 ms |
| With monitored start typ. | 130 ms | 130 ms | 130 ms |
| With monitored start max. | 180 ms | 180 ms | 180 ms |
| Delay-on de-energisation | | | |
| With E-STOP typ. | 15 ms | 15 ms | 15 ms |
| With E-STOP max. | 30 ms | 30 ms | 30 ms |
| With power failure typ. | 100 ms | 160 ms | 160 ms |
| With power failure max. | 200 ms | 220 ms | 220 ms |
| Recovery time at max. switching frequency 1/s | | | |
| After E-STOP | 50 ms | 50 ms | 50 ms |
| After power failure | 180 ms | 250 ms | 250 ms |
| Min. start pulse duration with a monitored start | | | |
| | 30 ms | 30 ms | 30 ms |
| Supply interruption before de-energisation | | | |
| | 35 ms | 35 ms | 35 ms |
| Environmental data | 787760 | 787764 | 787766 |
| Climatic suitability | EN 60068-2-78 | EN 60068-2-78 | EN 60068-2-78 |
| Ambient temperature | | | |
| Temperature range | -10 - 55 °C | -10 - 55 °C | -10 - 55 °C |
| Storage temperature | | | |
| Temperature range | -40 - 85 °C | -40 - 85 °C | -40 - 85 °C |
| Climatic suitability | | | |
| Humidity | 93 % r. h. at 40 °C | 93 % r. h. at 40 °C | 93 % r. h. at 40 °C |
| Condensation during operation | | | |
| | Not permitted | Not permitted | Not permitted |
| EMC | | | |
| | EN 60947-5-1, EN 61000-6-2, EN 61326-3-1 | EN 60947-5-1, EN 61000-6-2, EN 61326-3-1 | EN 60947-5-1, EN 61000-6-2, EN 61326-3-1 |

Safety relays PNOZ X PNOZ X8P

| Environmental data | 787760 | 787764 | 787766 |
|---|---|---|---|
| Vibration | | | |
| In accordance with the standard | EN 60068-2-6 | EN 60068-2-6 | EN 60068-2-6 |
| Frequency | 10 - 55 Hz | 10 - 55 Hz | 10 - 55 Hz |
| Amplitude | 0,35 mm | 0,35 mm | 0,35 mm |
| Airgap creepage | | | |
| In accordance with the standard | EN 60947-1 | EN 60947-1 | EN 60947-1 |
| Overvoltage category | III / II | III / II | III / II |
| Pollution degree | 2 | 2 | 2 |
| Rated insulation voltage | 250 V | 250 V | 250 V |
| Rated impulse withstand voltage | 4 kV | 4 kV | 4 kV |
| Protection type | | | |
| Mounting area (e.g. control cabinet) | IP54 | IP54 | IP54 |
| Housing | IP40 | IP40 | IP40 |
| Terminals | IP20 | IP20 | IP20 |
| Mechanical data | 787760 | 787764 | 787766 |
| Mounting position | Any | Any | Any |
| Mechanical life | 10,000,000 cycles | 10,000,000 cycles | 10,000,000 cycles |
| Material | | | |
| Bottom | PPO UL 94 V0 | PPO UL 94 V0 | PPO UL 94 V0 |
| Front | ABS UL 94 V0 | ABS UL 94 V0 | ABS UL 94 V0 |
| Top | PPO UL 94 V0 | PPO UL 94 V0 | PPO UL 94 V0 |
| Connection type | Cage clamp terminal | Cage clamp terminal | Cage clamp terminal |
| Mounting type | plug-in | plug-in | plug-in |
| Conductor cross section with spring-loaded terminals: Flexible with/without crimp connector | 0,2 - 1,5 mm ² , 24 - 16 AWG | 0,2 - 1,5 mm ² , 24 - 16 AWG | 0,2 - 1,5 mm ² , 24 - 16 AWG |
| Spring-loaded terminals: Terminal points per connection | 2 | 2 | 2 |
| Stripping length with spring-loaded terminals | 8 mm | 8 mm | 8 mm |
| Dimensions | | | |
| Height | 101 mm | 101 mm | 101 mm |
| Width | 45 mm | 45 mm | 45 mm |
| Depth | 121 mm | 121 mm | 121 mm |
| Weight | 315 g | 415 g | 415 g |

Where standards are undated, the 2014-07 latest editions shall apply.

Safety relays PNOZ X PNOZ X8P

Technical details Order no. 787768-787770

| General | 787768 | 787770 |
|---|--|--|
| Approvals | CCC, CE, EAC (Eurasian), TÜV, cULus Listed | CCC, CE, EAC (Eurasian), TÜV, cULus Listed |
| Electrical data | 787768 | 787770 |
| Supply voltage | | |
| Voltage | 230 V | 24 V |
| Kind | AC | AC |
| Voltage tolerance | -15 %/+10 % | -15 %/+10 % |
| Output of external power supply (AC) | 6,5 VA | 6,5 VA |
| Frequency range AC | 50 - 60 Hz | 50 - 60 Hz |
| Duty cycle | 100 % | 100 % |
| Inputs | 787768 | 787770 |
| Number | 2 | 2 |
| Voltage at | | |
| Input circuit DC | 24 V | 24 V |
| Start circuit DC | 24 V | 24 V |
| Feedback loop DC | 24 V | 24 V |
| Current at | | |
| Input circuit DC | 40 mA | 40 mA |
| Start circuit DC | 60 mA | 60 mA |
| Feedback loop DC | 60 mA | 60 mA |
| Min. input resistance at power-on | 89 Ohm | 89 Ohm |
| Max. overall cable resistance RI-max | | |
| Single-channel at UB AC | 100 Ohm | 100 Ohm |
| Dual-channel without detection of shorts across contacts at UB AC | 200 Ohm | 200 Ohm |
| Dual-channel with detection of shorts across contacts at UB AC | 28 Ohm | 28 Ohm |
| Semiconductor outputs | 787768 | 787770 |
| Number | 2 | 2 |
| Voltage | 24 V | 24 V |
| Current | 50 mA | 50 mA |
| External supply voltage | 24 V | 24 V |
| Voltage tolerance | -20 %/+20 % | -20 %/+20 % |

Safety relays PNOZ X PNOZ X8P

| Relay outputs | 787768 | 787770 |
|--|--------------|--------------|
| Number of output contacts | | |
| Safety contacts (N/O), instantaneous | 3 | 3 |
| Auxiliary contacts (N/C) | 2 | 2 |
| Max. short circuit current IK | 1 kA | 1 kA |
| Utilisation category | | |
| In accordance with the standard | EN 60947-4-1 | EN 60947-4-1 |
| Utilisation category of safety contacts | | |
| AC1 at | 240 V | 240 V |
| Min. current | 0,01 A | 0,01 A |
| Max. current | 8 A | 8 A |
| Max. power | 2000 VA | 2000 VA |
| DC1 at | 24 V | 24 V |
| Min. current | 0,01 A | 0,01 A |
| Max. current | 8 A | 8 A |
| Max. power | 200 W | 200 W |
| Utilisation category of auxiliary contacts | | |
| AC1 at | 240 V | 240 V |
| Min. current | 0,01 A | 0,01 A |
| Max. current | 8 A | 8 A |
| Max. power | 2000 VA | 2000 VA |
| DC1 at | 24 V | 24 V |
| Min. current | 0,01 A | 0,01 A |
| Max. current | 8 A | 8 A |
| Max. power | 200 W | 200 W |
| Utilisation category | | |
| In accordance with the standard | EN 60947-5-1 | EN 60947-5-1 |
| Utilisation category of safety contacts | | |
| AC15 at | 230 V | 230 V |
| Max. current | 5 A | 5 A |
| DC13 (6 cycles/min) at | 24 V | 24 V |
| Max. current | 7 A | 7 A |
| Utilisation category of auxiliary contacts | | |
| AC15 at | 230 V | 230 V |
| Max. current | 5 A | 5 A |
| DC13 (6 cycles/min) at | 24 V | 24 V |
| Max. current | 7 A | 7 A |

Safety relays PNOZ X PNOZ X8P

| Relay outputs | 787768 | 787770 |
|--|--------------------------------|--------------------------------|
| Utilisation category in accordance with UL | | |
| Voltage | 240 V AC G. P. | 240 V AC G. P. |
| With current | 8 A | 8 A |
| Voltage | 24 V DC Resistive | 24 V DC Resistive |
| With current | 5 A | 5 A |
| Pilot Duty | B300, R300 | B300, R300 |
| External contact fuse protection, safety contacts | | |
| In accordance with the standard | EN 60947-5-1 | EN 60947-5-1 |
| Max. melting integral | 240 A ² s | 240 A ² s |
| Blow-out fuse, quick | 10 A | 10 A |
| Blow-out fuse, slow | 6 A | 6 A |
| Blow-out fuse, gG | 10 A | 10 A |
| Circuit breaker 24V AC/DC, characteristic B/C | 6 A | 6 A |
| External contact fuse protection, auxiliary contacts | | |
| Max. melting integral | 240 A ² s | 240 A ² s |
| Blow-out fuse, quick | 10 A | 10 A |
| Blow-out fuse, slow | 6 A | 6 A |
| Blow-out fuse, gG | 10 A | 10 A |
| Circuit breaker 24 V AC/DC, characteristic B/C | 6 A | 6 A |
| Contact material | AgSnO ₂ + 0,2 µm Au | AgSnO ₂ + 0,2 µm Au |
| Conventional thermal current while loading several contacts | 787768 | 787770 |
| I _{th} per contact at UB AC; AC1: 240 V, DC1: 24 V | | |
| Conv. therm. current with 1 contact | 8 A | 8 A |
| Conv. therm. current with 2 contacts | 7,3 A | 7,3 A |
| Conv. therm. current with 3 contacts | 6 A | 6 A |

Safety relays PNOZ X PNOZ X8P

| Times | 787768 | 787770 |
|--|--|--|
| Switch-on delay | | |
| With automatic start typ. | 175 ms | 175 ms |
| With automatic start max. | 220 ms | 220 ms |
| With automatic start after power on typ. | 200 ms | 200 ms |
| With automatic start after power on max. | 250 ms | 250 ms |
| With manual start typ. | 190 ms | 190 ms |
| With manual start max. | 250 ms | 250 ms |
| With monitored start typ. | 130 ms | 130 ms |
| With monitored start max. | 180 ms | 180 ms |
| Delay-on de-energisation | | |
| With E-STOP typ. | 15 ms | 15 ms |
| With E-STOP max. | 30 ms | 30 ms |
| With power failure typ. | 160 ms | 160 ms |
| With power failure max. | 220 ms | 220 ms |
| Recovery time at max. switching frequency 1/s | | |
| After E-STOP | 50 ms | 50 ms |
| After power failure | 250 ms | 250 ms |
| Min. start pulse duration with a monitored start | 30 ms | 30 ms |
| Supply interruption before de-energisation | 35 ms | 35 ms |
| Environmental data | 787768 | 787770 |
| Climatic suitability | EN 60068-2-78 | EN 60068-2-78 |
| Ambient temperature | | |
| Temperature range | -10 - 55 °C | -10 - 55 °C |
| Storage temperature | | |
| Temperature range | -40 - 85 °C | -40 - 85 °C |
| Climatic suitability | | |
| Humidity | 93 % r. h. at 40 °C | 93 % r. h. at 40 °C |
| Condensation during operation | Not permitted | Not permitted |
| EMC | EN 60947-5-1, EN 61000-6-2, EN 61326-3-1 | EN 60947-5-1, EN 61000-6-2, EN 61326-3-1 |
| Vibration | | |
| In accordance with the standard | EN 60068-2-6 | EN 60068-2-6 |
| Frequency | 10 - 55 Hz | 10 - 55 Hz |
| Amplitude | 0,35 mm | 0,35 mm |

Safety relays PNOZ X PNOZ X8P

| Environmental data | 787768 | 787770 |
|---|--|--|
| Airgap creepage | | |
| In accordance with the standard | EN 60947-1 | EN 60947-1 |
| Overvoltage category | III / II | III / II |
| Pollution degree | 2 | 2 |
| Rated insulation voltage | 250 V | 250 V |
| Rated impulse withstand voltage | 4 kV | 4 kV |
| Protection type | | |
| Mounting area (e.g. control cabinet) | IP54 | IP54 |
| Housing | IP40 | IP40 |
| Terminals | IP20 | IP20 |
| Mechanical data | 787768 | 787770 |
| Mounting position | Any | Any |
| Mechanical life | 10,000,000 cycles | 10,000,000 cycles |
| Material | | |
| Bottom | PPO UL 94 V0 | PPO UL 94 V0 |
| Front | ABS UL 94 V0 | ABS UL 94 V0 |
| Top | PPO UL 94 V0 | PPO UL 94 V0 |
| Connection type | Cage clamp terminal | Cage clamp terminal |
| Mounting type | plug-in | plug-in |
| Conductor cross section with spring-loaded terminals: Flexible with/without crimp connector | 0,2 - 1,5 mm², 24 - 16 AWG | 0,2 - 1,5 mm², 24 - 16 AWG |
| Spring-loaded terminals: Terminal points per connection | 2 | 2 |
| Stripping length with spring-loaded terminals | 8 mm | 8 mm |
| Dimensions | | |
| Height | 101 mm | 101 mm |
| Width | 45 mm | 45 mm |
| Depth | 121 mm | 121 mm |
| Weight | 415 g | 415 g |

Where standards are undated, the 2014-07 latest editions shall apply.

Safety relays PNOZ X PNOZ X8P

Safety characteristic data

| Operating Mode | EN ISO 13849-1: 2015 | EN ISO 13849-1: 2015 | EN 62061 SIL CL | EN 62061 PFH _D [1/h] | IEC 61511 SIL | IEC 61511 PFD | EN ISO 13849-1: 2015 T _M [year] |
|----------------|----------------------|----------------------|-----------------|---------------------------------|---------------|---------------|--|
| PL | Category | | | | | | |
| – | PL e | Cat. 4 | SIL CL 3 | 2,31E-09 | SIL 3 | 2,03E-06 | 20 |

All the units used within a safety function must be considered when calculating the safety characteristic data.

The PFH value depends on the switching frequency and the load on the relay output. If the service life graphs are not accessible, the stated PFH value can be used irrespective of the switching frequency and the load, as the PFH value already considers the relay's B10d value as well as the failure rates of the other components.

Supplementary data

Service life graph

The service life graphs indicate the number of cycles from which failures due to wear must be expected. The wear is mainly caused by the electrical load; the mechanical load is negligible.

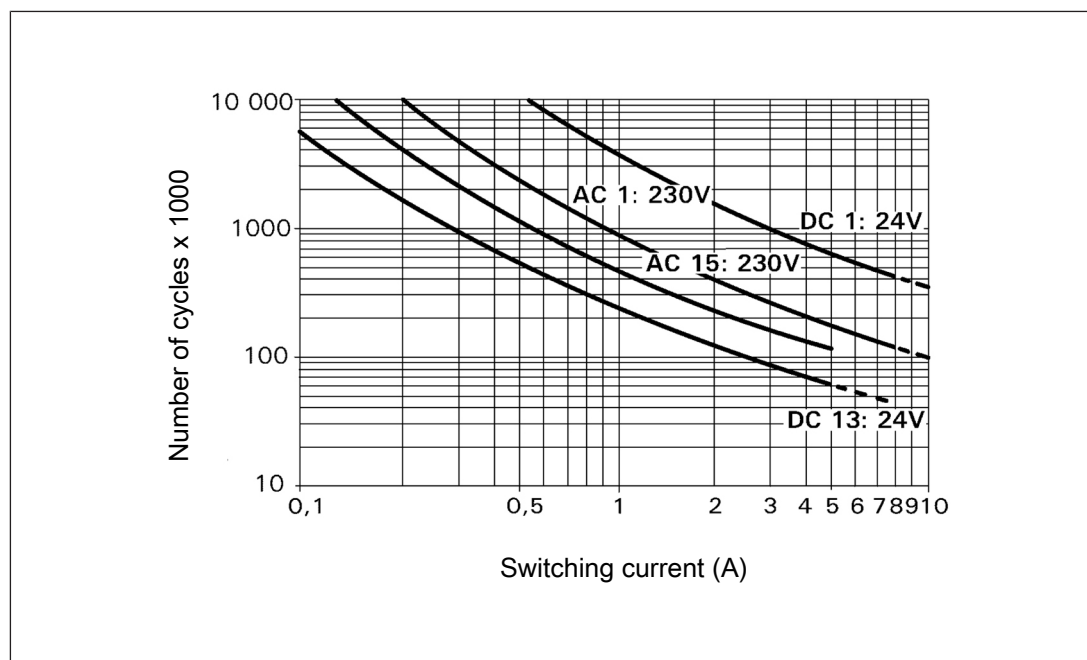

Safety relays PNOZ X PNOZ X8P

Example

- ▶ Inductive load: 0.2 A
- ▶ Utilisation category: AC15
- ▶ Contact service life: 4 000 000 cycles

Provided the application to be implemented requires fewer than 4 000 000 cycles, the PFH value (see Technical details) can be used in the calculation.

To increase the service life, sufficient spark suppression must be provided on all output contacts. With capacitive loads, any power surges that occur must be noted. With DC contactors, use flywheel diodes for spark suppression.

Order reference

| Product type | Features | Connection type | Order no. |
|--------------|----------|-------------------------|-----------|
| PNOZ X8P | 24 VAC | Screw terminals | 777 770 |
| PNOZ X8P C | 24 VAC | Spring-loaded terminals | 787 770 |
| PNOZ X8P | 110 V AC | Screw terminals | 777 764 |
| PNOZ X8P C | 110 V AC | Spring-loaded terminals | 787 764 |
| PNOZ X8P | 115 V AC | Screw terminals | 777 765 |
| PNOZ X8P | 120 V AC | Screw terminals | 777 766 |
| PNOZ X8P C | 120 V AC | Spring-loaded terminals | 787 766 |
| PNOZ X8P | 230 V AC | Screw terminals | 777 768 |
| PNOZ X8P C | 230 V AC | Spring-loaded terminals | 787 768 |
| PNOZ X8P | 24 VDC | Screw terminals | 777 760 |
| PNOZ X8P C | 24 VDC | Spring-loaded terminals | 787 760 |

Safety relays PNOZ X PNOZ X9P

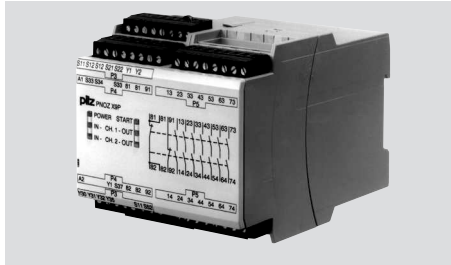

Unit features

- ▶ Positive-guided relay outputs:
 - 7 safety contacts (N/O), instantaneous
 - 2 auxiliary contacts (N/C), instantaneous
- ▶ 2 semiconductor outputs
- ▶ Connection options for:
 - E-STOP pushbuttons
 - Safety gate limit switches
 - Start buttons
 - Light grids and safety switches with detection of shorts across contacts
- ▶ LED indicator for:
 - Supply voltage
 - Input state
 - Switch state of the safety contacts
 - Start circuit
- ▶ Semiconductor outputs signal:
 - Supply voltage is present
 - Switch status of the safety contacts
- ▶ Plug-in connection terminals (either spring-loaded terminal or screw terminal)
- ▶ See order reference for unit types

Safety relays PNOZ X PNOZ X9P

Block diagram/terminal configuration

Types: DC

- ▶ U_B : 12 VDC; Order no. 777607
- ▶ U_B : 24 VDC; Order no. 777609, 787609

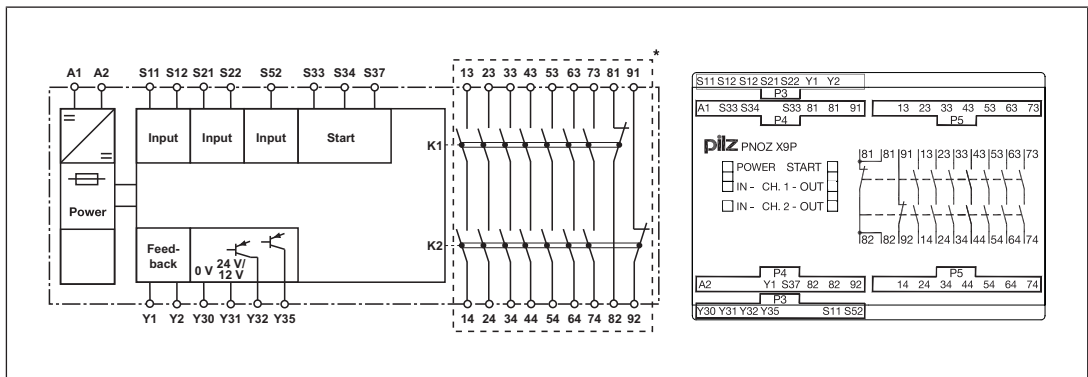

*Insulation between the non-marked area and the relay contacts: Basic insulation (over-voltage category III), Protective separation (overvoltage category II)

Type: AC/DC

- ▶ U_B : 24-240 V AC/DC, 24 V DC; Order no. 777606, 787606

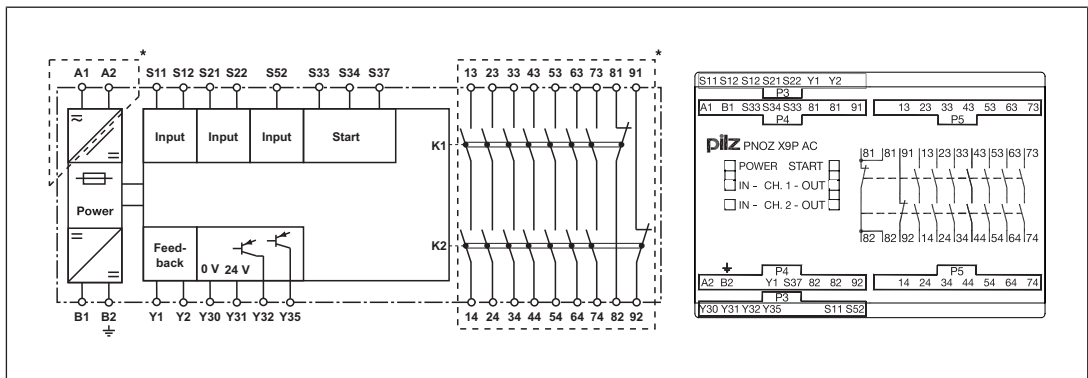

*Insulation between the non-marked area and the relay contacts: Basic insulation (over-voltage category III), Protective separation (overvoltage category II)

Safety relays PNOZ X PNOZ X9P

Function Description

The safety relay PNOZ X9P provides a safety-oriented interruption of a safety circuit. When supply voltage is supplied the "POWER" LED is lit. The unit is ready for operation when the feedback loop Y1-Y2 and the start circuit S33-S34 are closed. The "START" LED is lit.

- ▶ Input circuit is closed (e.g. E-STOP pushbutton not operated):
 - The LEDs "CH.1 IN" and "CH.2 IN" are lit.
 - Safety contacts 13-14, 23-24, 33-34, 43-44, 53-54, 63-64 and 73-74 are closed, the auxiliary contacts 81-82 and 91-92 are opened. The unit is active.
 - A high signal is present at the semiconductor output switch state Y32.
 - The LEDs "CH.1 OUT" and "CH.2 OUT" are lit. The "START" LED goes out.
- ▶ Input circuit is opened (e.g. E-STOP pushbutton operated):
 - The LEDs "CH.1 IN" and "CH.2 IN" go out.
 - Safety contacts 13-14, 23-24, 33-34, 43-44, 53-54, 63-64 and 73-74 are opened redundantly, the auxiliary contacts 81-82 and 91-92 are closed.
 - A low signal is present at the semiconductor output switch state Y32.
 - The LEDs "CH.1 OUT" and "CH.2 OUT" go out.
- ▶ A high signal is present at semi-conductor output Y35 if the supply voltage is present and the internal fuse has not blown.

Operating modes

- ▶ Single-channel operation: No redundancy in the input circuit, earth faults in the start and input circuit are detected.
- ▶ Dual-channel operation without detection of shorts across contacts: Redundant input circuit, detects PNOZ X9P
 - earth faults in the start and input circuit,
 - short circuits in the input circuit.
- ▶ Dual-channel operation with detection of shorts across contacts: Redundant input circuit, PNOZ X9P detects
 - earth faults in the start and input circuit,
 - short circuits in the input circuit,
 - shorts across contacts in the input circuit.
- ▶ Automatic start: Unit is active once the input circuit has been closed.
- ▶ Manual start: Unit is active once the input circuit and the start circuit are closed.
- ▶ Monitored start: Unit is active once
 - the input circuit is closed and then the start circuit is closed and opened again.
 - the start circuit is closed and then opened again once the input circuit is closed.

Safety relays PNOZ X PNOZ X9P

- ▶ Increase in the number of available contacts by connecting contact expander modules or external contactors/relays.

Timing diagram

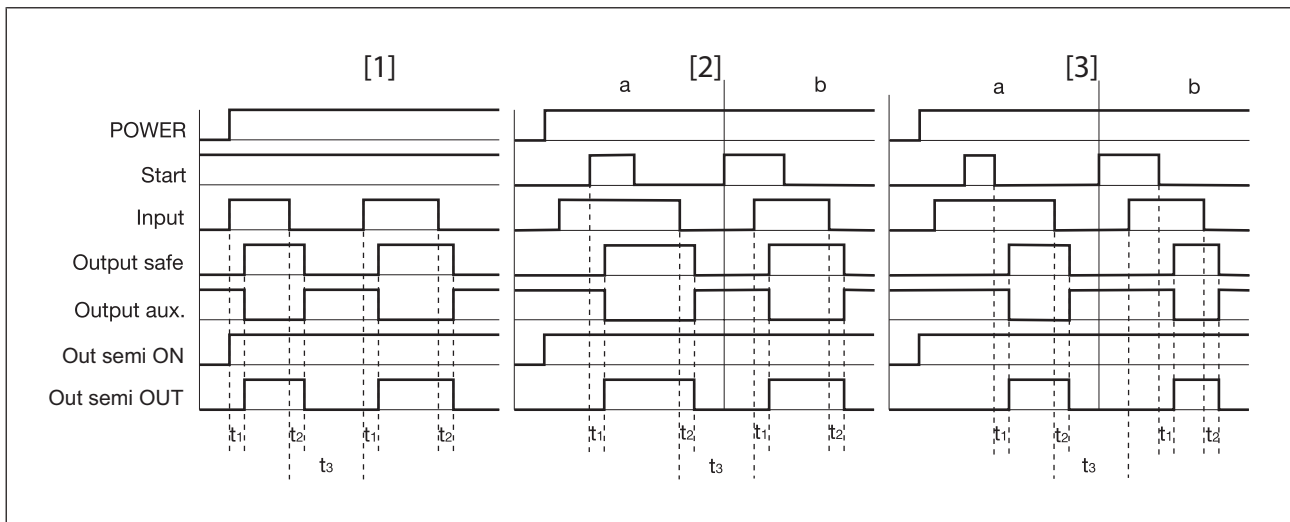

Legend

- ▶ Power: Supply voltage
- ▶ Start: Start circuit
- ▶ Input: Input circuit
- ▶ Output safe: Safety contacts
- ▶ Output aux.: Auxiliary contacts
- ▶ Out semi ON: Semiconductor output supply voltage
- ▶ Out semi OUT: Semiconductor output switch state
- ▶ [1]: Automatic start
- ▶ [2]: Manual start
- ▶ [3]: Monitored start
- ▶ a: Input circuit closes before start circuit
- ▶ b: Start circuit closes before input circuit
- ▶ t_1 : Switch-on delay
- ▶ t_2 : Delay-on de-energisation
- ▶ t_3 : Recovery time

Safety relays PNOZ X PNOZ X9P

Installation

- ▶ The unit should be installed in a control cabinet with a protection type of at least IP54.
- ▶ Use the notch on the rear of the unit to attach it to a DIN rail.
- ▶ Ensure the unit is mounted securely on a vertical DIN rail (35 mm) by using a fixing element (e.g. retaining bracket or an end angle).

Wiring

Please note:

- ▶ Information given in the "[Technical details \[222\]](#)" must be followed.
- ▶ Delivery status of units with screw terminals: Link between Y1-Y2 (feedback loop)
- ▶ Outputs 13-14, 23-24, 33-34, 43-44, 53-54, 63-64, 73-74 are safety contacts, the outputs 81-82, 91-92 are auxiliary contacts (e.g. for display).
- ▶ Do **not** use auxiliary contacts 81-82, 91-92 and semiconductor outputs Y32, Y35 for safety circuits!
- ▶ Do not connect undesignated terminals.
- ▶ To prevent contact welding, a fuse should be connected before the output contacts (see [Technical details \[222\]](#)).
- ▶ Calculation of the max. cable length l_{\max} in the input circuit:

$$l_{\max} = \frac{R_{l_{\max}}}{R_l / \text{km}}$$

$R_{l_{\max}}$ = max. overall cable resistance (see [Technical details \[222\]](#))

R_l / km = cable resistance/km

- ▶ Use copper wire that can withstand 60/75 °C.
- ▶ Sufficient fuse protection must be provided on all output contacts with capacitive and inductive loads.
- ▶ Do not switch low currents using contacts that have been used previously with high currents.
- ▶ When connecting magnetically operated, reed proximity switches, ensure that the max. peak inrush current (on the input circuit) does not overload the proximity switch.
- ▶ 777607, 777609, 787609 units or 777606, 787606 units, when the supply voltage is connected via B1 and B2:
The power supply must comply with the regulations for extra low voltages with safe electrical separation (SELV, PELV) in accordance with VDE 0100, part 410.
- ▶ Ensure the wiring and EMC requirements of IEC 60204-1 are met.

Safety relays PNOZ X PNOZ X9P

Important for detection of shorts across contacts:

As this function for detecting shorts across contacts is not failsafe, it is tested by Pilz during the final control check. If there is a danger of exceeding the cable runs, we recommend the following test after the installation of the device:

1. Unit ready for operation (output contacts closed)
2. Short circuit the test terminals S12, S22 for detecting shorts across the inputs.
3. The unit's fuse must be triggered and the output contacts must open. Cable lengths in the scale of the maximum length can delay the fuse triggering for up to 2 minutes.
4. Reset the fuse: remove the short circuit and switch off the supply voltage for approx. 1 minute.

Preparing for operation

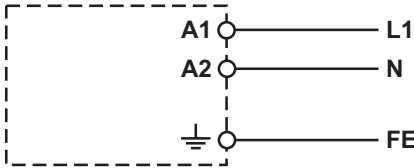
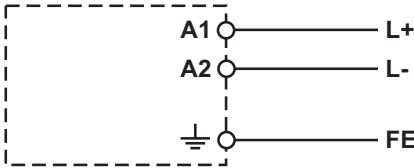
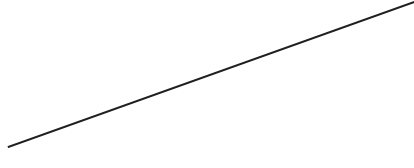
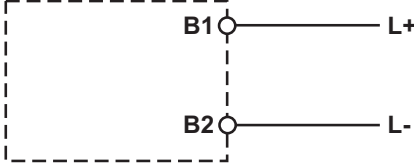
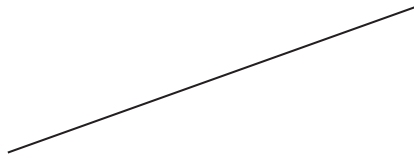
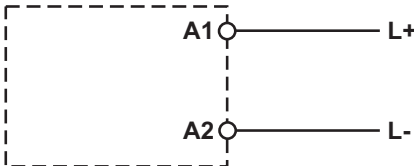
| Supply voltage | AC | DC |
|--|--|---|
| <p>▶ Order no. 777606, 787606 U_B: 24-240 V AC/DC via A1 and A2</p> |  |  |
| <p>▶ Order no. 777606, 787606 U_B: 24 V DC via B1 and B2</p> |  |  |
| Supply voltage | AC | DC |
| <p>▶ Order no. 777607 U_B: 12 V DC</p> <p>▶ Order no. 777609, 787609 U_B: 24 VDC</p> |  |  |

Safety relays PNOZ X PNOZ X9P

| Input circuit | Single-channel | Dual-channel |
|--|----------------|--------------|
| E-STOP without detection of shorts across contacts | | |
| E-STOP with detection of shorts across contacts | | |
| Safety gate without detection of shorts across contacts | | |
| Safety gate with detection of shorts across contacts | | |
| Light guard or safety switch, detection of shorts across contacts via ESPE ▶ Order no. 777609, 787609 U _B : 24 VDC | | |
| Light guard or safety switch, detection of shorts across contacts via ESPE ▶ Order no. 777606, 787606 U _B : 24 V DC via B1 and B2 | | |



Safety relays PNOZ X PNOZ X9P

| | Single-channel, dual-channel without detection of shorts across contacts | Dual-channel with detection of shorts across contacts |
|--|--|---|
| Start circuit | | |
| Automatic start | | |
| Automatic start with start-up test (safety gate, dual-channel) | <p>Simultaneity S1 and S2: 150 ms, U_B: 12 V DC: 50 ms</p> | |
| Manual start | | |
| Monitored start | | |
| Feedback loop | without feedback loop monitoring | with feedback loop monitoring |
| Link or contacts from external contactors | | |

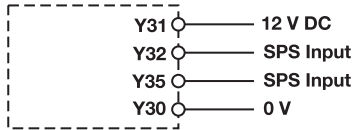
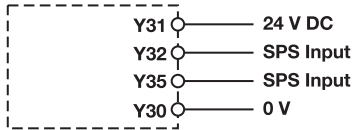
Safety relays PNOZ X PNOZ X9P

| Semiconductor output | U _B : 12 V DC | U _B : 24 V DC; 24-240 V AC/DC |
|-----------------------------------|--|--|
| Y31, Y30: External supply voltage |  <p>Y31 — 12 V DC Y32 — SPS Input Y35 — SPS Input Y30 — 0 V</p> |  <p>Y31 — 24 V DC Y32 — SPS Input Y35 — SPS Input Y30 — 0 V</p> |

Legend

- ▶ S1/S2: E-STOP/safety gate switch
- ▶ S3: Reset button
- ▶ ↑↑: Switch operated
- ▶ : Gate open
- ▶ : Gate closed

Dimensions in mm

* with spring-loaded terminals

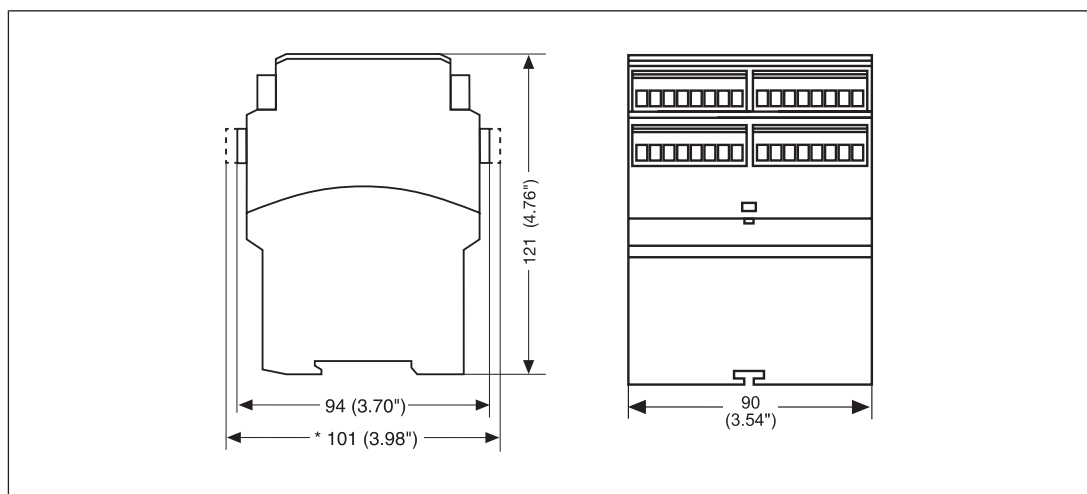

Safety relays PNOZ X PNOZ X9P

Technical details

Order no. 777606 – 787606

See below for more order numbers

| General | 777606 | 787606 |
|--------------------------------------|--|--|
| Approvals | CCC, CE, EAC (Eurasian), TÜV, cULus Listed | CCC, CE, EAC (Eurasian), TÜV, cULus Listed |
| Electrical data | 777606 | 787606 |
| Supply voltage | | |
| Voltage | 24 - 240 V | 24 - 240 V |
| Kind | AC/DC | AC/DC |
| Voltage tolerance | -15 %/+10 % | -15 %/+10 % |
| Output of external power supply (AC) | 8,5 VA | 8,5 VA |
| Output of external power supply (DC) | 5,5 W | 5,5 W |
| Frequency range AC | 50 - 60 Hz | 50 - 60 Hz |
| Supply voltage | | |
| Voltage | 24 V | 24 V |
| Kind | DC | DC |
| Voltage tolerance | -15 %/+10 % | -15 %/+10 % |
| Output of external power supply (DC) | 5,5 W | 5,5 W |
| Residual ripple DC | 160 % | 160 % |
| Duty cycle | 100 % | 100 % |
| Inputs | 777606 | 787606 |
| Number | 2 | 2 |
| Voltage at | | |
| Input circuit DC | 24 V | 24 V |
| Start circuit DC | 24 V | 24 V |
| Feedback loop DC | 24 V | 24 V |
| Current at | | |
| Input circuit DC | 50 mA | 50 mA |
| Start circuit DC | 100 mA | 100 mA |
| Feedback loop DC | 100 mA | 100 mA |
| Min. input resistance at power-on | 89 Ohm | 89 Ohm |

Safety relays PNOZ X PNOZ X9P

| Inputs | 777606 | 787606 |
|---|---------------------|---------------------|
| Max. overall cable resistance RI-max | | |
| Single-channel at UB DC | 45 Ohm | 45 Ohm |
| Single-channel at UB AC | 45 Ohm | 45 Ohm |
| Dual-channel without detection of shorts across contacts at UB DC | 90 Ohm | 90 Ohm |
| Dual-channel without detection of shorts across contacts at UB AC | 90 Ohm | 90 Ohm |
| Dual-channel with detection of shorts across contacts at UB DC | 15 Ohm | 15 Ohm |
| Dual-channel with detection of shorts across contacts at UB AC | 15 Ohm | 15 Ohm |
| Semiconductor outputs | 777606 | 787606 |
| Number | 2 | 2 |
| Voltage | 24 V | 24 V |
| Current | 20 mA | 20 mA |
| External supply voltage | 24 V | 24 V |
| Voltage tolerance | -20 %/+20 % | -20 %/+20 % |
| Relay outputs | 777606 | 787606 |
| Number of output contacts | | |
| Safety contacts (N/O), instantaneous | 7 | 7 |
| Auxiliary contacts (N/C) | 2 | 2 |
| Max. short circuit current IK | 1 kA | 1 kA |
| Utilisation category | | |
| In accordance with the standard | EN 60947-4-1 | EN 60947-4-1 |
| Utilisation category of safety contacts | | |
| AC1 at | 240 V | 240 V |
| Min. current | 0,01 A | 0,01 A |
| Max. current | 8 A | 8 A |
| Max. power | 2000 VA | 2000 VA |
| DC1 at | 24 V | 24 V |
| Min. current | 0,01 A | 0,01 A |
| Max. current | 8 A | 8 A |
| Max. power | 200 W | 200 W |

Safety relays PNOZ X PNOZ X9P

| Relay outputs | 777606 | 787606 |
|---|---------------------------|---------------------------|
| Utilisation category of auxiliary contacts | | |
| AC1 at | 240 V | 240 V |
| Min. current | 0,01 A | 0,01 A |
| Max. current | 8 A | 8 A |
| Max. power | 2000 VA | 2000 VA |
| DC1 at | 24 V | 24 V |
| Min. current | 0,01 A | 0,01 A |
| Max. current | 8 A | 8 A |
| Max. power | 200 W | 200 W |
| Utilisation category | | |
| In accordance with the standard | EN 60947-5-1 | EN 60947-5-1 |
| Utilisation category of safety contacts | | |
| AC15 at | 230 V | 230 V |
| Max. current | 5 A | 5 A |
| DC13 (6 cycles/min) at | 24 V | 24 V |
| Max. current | 7 A | 7 A |
| Utilisation category of auxiliary contacts | | |
| AC15 at | 230 V | 230 V |
| Max. current | 5 A | 5 A |
| DC13 (6 cycles/min) at | 24 V | 24 V |
| Max. current | 7 A | 7 A |
| Utilisation category in accordance with UL | | |
| Voltage | 240 V AC G. P. | 240 V AC G. P. |
| With current | 8 A | 8 A |
| Voltage | 24 V DC Resistive | 24 V DC Resistive |
| With current | 5 A | 5 A |
| Pilot Duty | B300, R300 | B300, R300 |
| External contact fuse protection, safety contacts | | |
| In accordance with the standard | EN 60947-5-1 | EN 60947-5-1 |
| Max. melting integral | 240 A²s | 240 A²s |
| Blow-out fuse, quick | 10 A | 10 A |
| Blow-out fuse, slow | 6 A | 6 A |
| Blow-out fuse, gG | 10 A | 10 A |
| Circuit breaker 24V AC/DC, characteristic B/C | 6 A | 6 A |

Safety relays PNOZ X PNOZ X9P

| Relay outputs | 777606 | 787606 |
|--|--------------------------------|--------------------------------|
| External contact fuse protection, auxiliary contacts | | |
| Max. melting integral | 240 A ² s | 240 A ² s |
| Blow-out fuse, quick | 10 A | 10 A |
| Blow-out fuse, slow | 6 A | 6 A |
| Blow-out fuse, gG | 10 A | 10 A |
| Circuit breaker 24 V AC/DC, characteristic B/C | 6 A | 6 A |
| Contact material | AgSnO ₂ + 0,2 µm Au | AgSnO ₂ + 0,2 µm Au |
| Conventional thermal current while loading several contacts | 777606 | 787606 |
| I _{th} per contact at UB AC; AC1: 240 V, DC1: 24 V | | |
| Conv. therm. current with 1 contact | 8 A | 8 A |
| Conv. therm. current with 2 contacts | 8 A | 8 A |
| Conv. therm. current with 3 contacts | 8 A | 8 A |
| Conv. therm. current with 4 contacts | 7 A | 7 A |
| Conv. therm. current with 5 contacts | 6 A | 6 A |
| Conv. therm. current with 6 contacts | 5,5 A | 5,5 A |
| Conv. therm. current with 7 contacts | 5 A | 5 A |
| I _{th} per contact at UB DC; AC1: 240 V, DC1: 24 V | | |
| Conv. therm. current with 1 contact | 8 A | 8 A |
| Conv. therm. current with 2 contacts | 8 A | 8 A |
| Conv. therm. current with 3 contacts | 8 A | 8 A |
| Conv. therm. current with 4 contacts | 7 A | 7 A |
| Conv. therm. current with 5 contacts | 6 A | 6 A |
| Conv. therm. current with 6 contacts | 5,5 A | 5,5 A |
| Conv. therm. current with 7 contacts | 5 A | 5 A |

Safety relays PNOZ X PNOZ X9P

| Times | 777606 | 787606 |
|---|---------------------|---------------------|
| Switch-on delay | | |
| With automatic start typ. | 200 ms | 200 ms |
| With automatic start max. | 250 ms | 250 ms |
| With automatic start after power on typ. | 500 ms | 500 ms |
| With automatic start after power on max. | 650 ms | 650 ms |
| With manual start typ. | 200 ms | 200 ms |
| With manual start max. | 250 ms | 250 ms |
| With monitored start typ. | 150 ms | 150 ms |
| With monitored start max. | 220 ms | 220 ms |
| Delay-on de-energisation | | |
| With E-STOP typ. | 20 ms | 20 ms |
| With E-STOP max. | 30 ms | 30 ms |
| With power failure at B1 typ. | 170 ms | 170 ms |
| With power failure at B1 max. | 250 ms | 250 ms |
| With 240 V power failure at A1 typ. | 430 ms | 430 ms |
| With 240 V power failure at A1 max. | 550 ms | 550 ms |
| With 24 V power failure at A1 typ. | 230 ms | 230 ms |
| With 24 V power failure at A1 max. | 300 ms | 300 ms |
| Recovery time at max. switching frequency 1/s | | |
| After E-STOP | 50 ms | 50 ms |
| After power failure at A1 | 600 ms | 600 ms |
| After power failure at B1 | 300 ms | 300 ms |
| Min. start pulse duration with a monitored start | | |
| | 50 ms | 50 ms |
| Supply interruption before de-energisation | | |
| | 20 ms | 20 ms |
| Environmental data | | |
| 777606 | | |
| 787606 | | |
| Climatic suitability | | |
| EN 60068-2-78 | | |
| EN 60068-2-78 | | |
| Ambient temperature | | |
| Temperature range | -10 - 55 °C | -10 - 55 °C |
| Storage temperature | | |
| Temperature range | -40 - 85 °C | -40 - 85 °C |
| Climatic suitability | | |
| Humidity | 93 % r. h. at 40 °C | 93 % r. h. at 40 °C |
| Condensation during operation | | |
| | Not permitted | Not permitted |

Safety relays PNOZ X PNOZ X9P

| Environmental data | 777606 | 787606 |
|---|--|--|
| EMC | EN 60947-5-1, EN 61000-6-2, EN 61326-3-1 | EN 60947-5-1, EN 61000-6-2, EN 61326-3-1 |
| Vibration | | |
| In accordance with the standard | EN 60068-2-6 | EN 60068-2-6 |
| Frequency | 10 - 55 Hz | 10 - 55 Hz |
| Amplitude | 0,35 mm | 0,35 mm |
| Airgap creepage | | |
| In accordance with the standard | EN 60947-1 | EN 60947-1 |
| Overvoltage category | III / II | III / II |
| Pollution degree | 2 | 2 |
| Rated insulation voltage | 250 V | 250 V |
| Rated impulse withstand voltage | 4 kV | 4 kV |
| Protection type | | |
| Mounting area (e.g. control cabinet) | IP54 | IP54 |
| Housing | IP40 | IP40 |
| Terminals | IP20 | IP20 |
| Mechanical data | 777606 | 787606 |
| Mounting position | Any | Any |
| Mechanical life | 10,000,000 cycles | 10,000,000 cycles |
| Material | | |
| Bottom | PPO UL 94 V0 | PPO UL 94 V0 |
| Front | ABS UL 94 V0 | ABS UL 94 V0 |
| Top | PPO UL 94 V0 | PPO UL 94 V0 |
| Connection type | Screw terminal | Spring-loaded terminal |
| Mounting type | plug-in | plug-in |
| Conductor cross section with screw terminals | | |
| 1 core flexible | 0,25 - 2,5 mm ² , 24 - 12 AWG | – |
| 2 core with the same cross section, flexible with crimp connectors, no plastic sleeve | 0,25 - 1 mm ² , 24 - 16 AWG | – |
| 2 core with the same cross section, flexible without crimp connectors or with TWIN crimp connectors | 0,2 - 1,5 mm ² , 24 - 16 AWG | – |
| Torque setting with screw terminals | 0,5 Nm | – |
| Conductor cross section with spring-loaded terminals: Flexible with/without crimp connector | – | 0,2 - 1,5 mm ² , 24 - 16 AWG |
| Spring-loaded terminals: Terminal points per connection | – | 2 |

Safety relays PNOZ X PNOZ X9P

| Mechanical data | 777606 | 787606 |
|---|--------|--------|
| Stripping length with spring-loaded terminals | – | 8 mm |
| Dimensions | | |
| Height | 94 mm | 101 mm |
| Width | 90 mm | 90 mm |
| Depth | 121 mm | 121 mm |
| Weight | 600 g | 600 g |

Where standards are undated, the 2014-07 latest editions shall apply.

Order no. 777607 -787609

| General | 777607 | 777609 | 787609 |
|--------------------------------------|--|--|--|
| Approvals | CCC, CE, EAC (Eurasian), TÜV, cULus Listed | CCC, CE, EAC (Eurasian), TÜV, cULus Listed | CCC, CE, EAC (Eurasian), TÜV, cULus Listed |
| Electrical data | 777607 | 777609 | 787609 |
| Supply voltage | | | |
| Voltage | 12 V | 24 V | 24 V |
| Kind | DC | DC | DC |
| Voltage tolerance | -20 %/+20 % | -15 %/+10 % | -15 %/+10 % |
| Output of external power supply (DC) | 7 W | 5,5 W | 5,5 W |
| Residual ripple DC | 160 % | 160 % | 160 % |
| Duty cycle | 100 % | 100 % | 100 % |
| Max. inrush current impulse | | | |
| Current pulse, A1 | 5,5 A | 10 A | 10 A |
| Pulse duration, A1 | 1 ms | 1 ms | 1 ms |
| Inputs | 777607 | 777609 | 787609 |
| Number | 2 | 2 | 2 |
| Voltage at | | | |
| Input circuit DC | 12 V | 24 V | 24 V |
| Start circuit DC | 12 V | 24 V | 24 V |
| Feedback loop DC | 12 V | 24 V | 24 V |
| Current at | | | |
| Input circuit DC | 130 mA | 50 mA | 50 mA |
| Start circuit DC | 200 mA | 100 mA | 100 mA |
| Feedback loop DC | 200 mA | 100 mA | 100 mA |
| Min. input resistance at power-on | 9 Ohm | 89 Ohm | 89 Ohm |

Safety relays PNOZ X PNOZ X9P

| Inputs | 777607 | 777609 | 787609 |
|---|--------------|--------------|--------------|
| Max. overall cable resistance R _{lmax} | | | |
| Single-channel at UB DC | 8 Ohm | 45 Ohm | 45 Ohm |
| Dual-channel without detection of shorts across contacts at UB DC | 15 Ohm | 90 Ohm | 90 Ohm |
| Dual-channel with detection of shorts across contacts at UB DC | 8 Ohm | 15 Ohm | 15 Ohm |
| Semiconductor outputs | 777607 | 777609 | 787609 |
| Number | 2 | 2 | 2 |
| Voltage | 12 V | 24 V | 24 V |
| Current | 20 mA | 20 mA | 20 mA |
| External supply voltage | 12 V | 24 V | 24 V |
| Voltage tolerance | -20 %/+20 % | -20 %/+20 % | -20 %/+20 % |
| Relay outputs | 777607 | 777609 | 787609 |
| Number of output contacts | | | |
| Safety contacts (N/O), instantaneous | 7 | 7 | 7 |
| Auxiliary contacts (N/C) | 2 | 2 | 2 |
| Max. short circuit current I _K | 1 kA | 1 kA | 1 kA |
| Utilisation category | | | |
| In accordance with the standard | EN 60947-4-1 | EN 60947-4-1 | EN 60947-4-1 |
| Utilisation category of safety contacts | | | |
| AC1 at | 240 V | 240 V | 240 V |
| Min. current | 0,01 A | 0,01 A | 0,01 A |
| Max. current | 8 A | 8 A | 8 A |
| Max. power | 2000 VA | 2000 VA | 2000 VA |
| DC1 at | 24 V | 24 V | 24 V |
| Min. current | 0,01 A | 0,01 A | 0,01 A |
| Max. current | 8 A | 8 A | 8 A |
| Max. power | 200 W | 200 W | 200 W |

Safety relays PNOZ X PNOZ X9P

| Relay outputs | 777607 | 777609 | 787609 |
|---|---------------------------|---------------------------|---------------------------|
| Utilisation category of auxiliary contacts | | | |
| AC1 at | 240 V | 240 V | 240 V |
| Min. current | 0,01 A | 0,01 A | 0,01 A |
| Max. current | 8 A | 8 A | 8 A |
| Max. power | 2000 VA | 2000 VA | 2000 VA |
| DC1 at | 24 V | 24 V | 24 V |
| Min. current | 0,01 A | 0,01 A | 0,01 A |
| Max. current | 8 A | 8 A | 8 A |
| Max. power | 200 W | 200 W | 200 W |
| Utilisation category | | | |
| In accordance with the standard | EN 60947-5-1 | EN 60947-5-1 | EN 60947-5-1 |
| Utilisation category of safety contacts | | | |
| AC15 at | 230 V | 230 V | 230 V |
| Max. current | 5 A | 5 A | 5 A |
| DC13 (6 cycles/min) at | 24 V | 24 V | 24 V |
| Max. current | 7 A | 7 A | 7 A |
| Utilisation category of auxiliary contacts | | | |
| AC15 at | 230 V | 230 V | 230 V |
| Max. current | 5 A | 5 A | 5 A |
| DC13 (6 cycles/min) at | 24 V | 24 V | 24 V |
| Max. current | 7 A | 7 A | 7 A |
| Utilisation category in accordance with UL | | | |
| Voltage | 240 V AC G. P. | 240 V AC G. P. | 240 V AC G. P. |
| With current | 8 A | 8 A | 8 A |
| Voltage | 24 V DC Resistive | 24 V DC Resistive | 24 V DC Resistive |
| With current | 5 A | 5 A | 5 A |
| Pilot Duty | B300, R300 | B300, R300 | B300, R300 |
| External contact fuse protection, safety contacts | | | |
| In accordance with the standard | EN 60947-5-1 | EN 60947-5-1 | EN 60947-5-1 |
| Max. melting integral | 240 A²s | 240 A²s | 240 A²s |
| Blow-out fuse, quick | 10 A | 10 A | 10 A |
| Blow-out fuse, slow | 6 A | 6 A | 6 A |
| Blow-out fuse, gG | 10 A | 10 A | 10 A |
| Circuit breaker 24V AC/DC, characteristic B/C | 6 A | 6 A | 6 A |

Safety relays PNOZ X PNOZ X9P

| Relay outputs | 777607 | 777609 | 787609 |
|--|--------------------------------------|--------------------------------------|--------------------------------------|
| External contact fuse protection, auxiliary contacts | | | |
| Max. melting integral | 240 A²s | 240 A²s | 240 A²s |
| Blow-out fuse, quick | 10 A | 10 A | 10 A |
| Blow-out fuse, slow | 6 A | 6 A | 6 A |
| Blow-out fuse, gG | 10 A | 10 A | 10 A |
| Circuit breaker 24 V AC/DC, characteristic B/C | 6 A | 6 A | 6 A |
| Contact material | AgSnO₂ + 0,2 µm Au | AgSnO₂ + 0,2 µm Au | AgSnO₂ + 0,2 µm Au |
| Conventional thermal current while loading several contacts | 777607 | 777609 | 787609 |
| I _{th} per contact at UB DC; AC1: 240 V, DC1: 24 V | | | |
| Conv. therm. current with 1 contact | 8 A | 8 A | 8 A |
| Conv. therm. current with 2 contacts | 8 A | 8 A | 8 A |
| Conv. therm. current with 3 contacts | 8 A | 8 A | 8 A |
| Conv. therm. current with 4 contacts | 7 A | 7 A | 7 A |
| Conv. therm. current with 5 contacts | 6 A | 6 A | 6 A |
| Conv. therm. current with 6 contacts | 5,5 A | 5,5 A | 5,5 A |
| Conv. therm. current with 7 contacts | 5 A | 5 A | 5 A |
| Times | 777607 | 777609 | 787609 |
| Switch-on delay | | | |
| With automatic start typ. | 130 ms | 200 ms | 200 ms |
| With automatic start max. | 200 ms | 250 ms | 250 ms |
| With automatic start after power on typ. | 150 ms | 220 ms | 220 ms |
| With automatic start after power on max. | 220 ms | 300 ms | 300 ms |
| With manual start typ. | 150 ms | 200 ms | 200 ms |
| With manual start max. | 200 ms | 250 ms | 250 ms |
| With monitored start typ. | 100 ms | 150 ms | 150 ms |
| With monitored start max. | 150 ms | 220 ms | 220 ms |

Safety relays PNOZ X PNOZ X9P

| Times | 777607 | 777609 | 787609 |
|--|--|--|--|
| Delay-on de-energisation | | | |
| With E-STOP typ. | 20 ms | 20 ms | 20 ms |
| With E-STOP max. | 30 ms | 30 ms | 30 ms |
| With power failure typ. | 60 ms | 170 ms | 170 ms |
| With power failure max. | 80 ms | 250 ms | 250 ms |
| Recovery time at max. switching frequency 1/s | | | |
| After E-STOP | 50 ms | 50 ms | 50 ms |
| After power failure | 100 ms | 300 ms | 300 ms |
| Min. start pulse duration with a monitored start | 30 ms | 50 ms | 50 ms |
| Supply interruption before de-energisation | 20 ms | 20 ms | 20 ms |
| Environmental data | 777607 | 777609 | 787609 |
| Climatic suitability | EN 60068-2-78 | EN 60068-2-78 | EN 60068-2-78 |
| Ambient temperature | | | |
| Temperature range | -10 - 55 °C | -10 - 55 °C | -10 - 55 °C |
| Storage temperature | | | |
| Temperature range | -40 - 85 °C | -40 - 85 °C | -40 - 85 °C |
| Climatic suitability | | | |
| Humidity | 93 % r. h. at 40 °C | 93 % r. h. at 40 °C | 93 % r. h. at 40 °C |
| Condensation during operation | Not permitted | Not permitted | Not permitted |
| EMC | EN 60947-5-1, EN 61000-6-2, EN 61326-3-1 | EN 60947-5-1, EN 61000-6-2, EN 61326-3-1 | EN 60947-5-1, EN 61000-6-2, EN 61326-3-1 |
| Vibration | | | |
| In accordance with the standard | EN 60068-2-6 | EN 60068-2-6 | EN 60068-2-6 |
| Frequency | 10 - 55 Hz | 10 - 55 Hz | 10 - 55 Hz |
| Amplitude | 0,35 mm | 0,35 mm | 0,35 mm |
| Airgap creepage | | | |
| In accordance with the standard | EN 60947-1 | EN 60947-1 | EN 60947-1 |
| Overvoltage category | III / II | III / II | III / II |
| Pollution degree | 2 | 2 | 2 |
| Rated insulation voltage | 250 V | 250 V | 250 V |
| Rated impulse withstand voltage | 4 kV | 4 kV | 4 kV |
| Protection type | | | |
| Mounting area (e.g. control cabinet) | IP54 | IP54 | IP54 |
| Housing | IP40 | IP40 | IP40 |
| Terminals | IP20 | IP20 | IP20 |

Safety relays PNOZ X PNOZ X9P

| Mechanical data | 777607 | 777609 | 787609 |
|---|--|--|---|
| Mounting position | Any | Any | Any |
| Mechanical life | 10,000,000 cycles | 10,000,000 cycles | 10,000,000 cycles |
| Material | | | |
| Bottom | PPO UL 94 V0 | PPO UL 94 V0 | PPO UL 94 V0 |
| Front | ABS UL 94 V0 | ABS UL 94 V0 | ABS UL 94 V0 |
| Top | PPO UL 94 V0 | PPO UL 94 V0 | PPO UL 94 V0 |
| Connection type | Screw terminal | Screw terminal | Spring-loaded terminal |
| Mounting type | plug-in | plug-in | plug-in |
| Conductor cross section with screw terminals | | | |
| 1 core flexible | 0,25 - 2,5 mm ² , 24 - 12 AWG | 0,25 - 2,5 mm ² , 24 - 12 AWG | – |
| 2 core with the same cross section, flexible with crimp connectors, no plastic sleeve | 0,25 - 1 mm ² , 24 - 16 AWG | 0,25 - 1 mm ² , 24 - 16 AWG | – |
| 2 core with the same cross section, flexible without crimp connectors or with TWIN crimp connectors | 0,2 - 1,5 mm ² , 24 - 16 AWG | 0,2 - 1,5 mm ² , 24 - 16 AWG | – |
| Torque setting with screw terminals | 0,5 Nm | 0,5 Nm | – |
| Conductor cross section with spring-loaded terminals: Flexible with/without crimp connector | – | – | 0,2 - 1,5 mm ² , 24 - 16 AWG |
| Spring-loaded terminals: Terminal points per connection | – | – | 2 |
| Stripping length with spring-loaded terminals | – | – | 8 mm |
| Dimensions | | | |
| Height | 94 mm | 94 mm | 101 mm |
| Width | 90 mm | 90 mm | 90 mm |
| Depth | 121 mm | 121 mm | 121 mm |
| Weight | 570 g | 570 g | 570 g |

Where standards are undated, the 2014-07 latest editions shall apply.

Safety relays PNOZ X PNOZ X9P

Safety characteristic data

| Operating Mode | EN ISO 13849-1: 2015 PL | EN ISO 13849-1: 2015 Category | EN 62061 SIL CL | EN 62061 PFH _D [1/h] | IEC 61511 SIL | IEC 61511 PFD | EN ISO 13849-1: 2015 T _M [year] |
|----------------|----------------------------|----------------------------------|--------------------|------------------------------------|------------------|------------------|---|
| – | PL e | Cat. 4 | SIL CL 3 | 2,31E-09 | SIL 3 | 2,03E-06 | 20 |

All the units used within a safety function must be considered when calculating the safety characteristic data.

Supplementary data

The PFH value depends on the switching frequency and the load on the relay output. If the service life graphs are not accessible, the stated PFH value can be used irrespective of the switching frequency and the load, as the PFH value already considers the relay's B10d value as well as the failure rates of the other components.

Safety relays PNOZ X PNOZ X9P

Service life graph

The service life graphs indicate the number of cycles from which failures due to wear must be expected. The wear is mainly caused by the electrical load; the mechanical load is negligible.

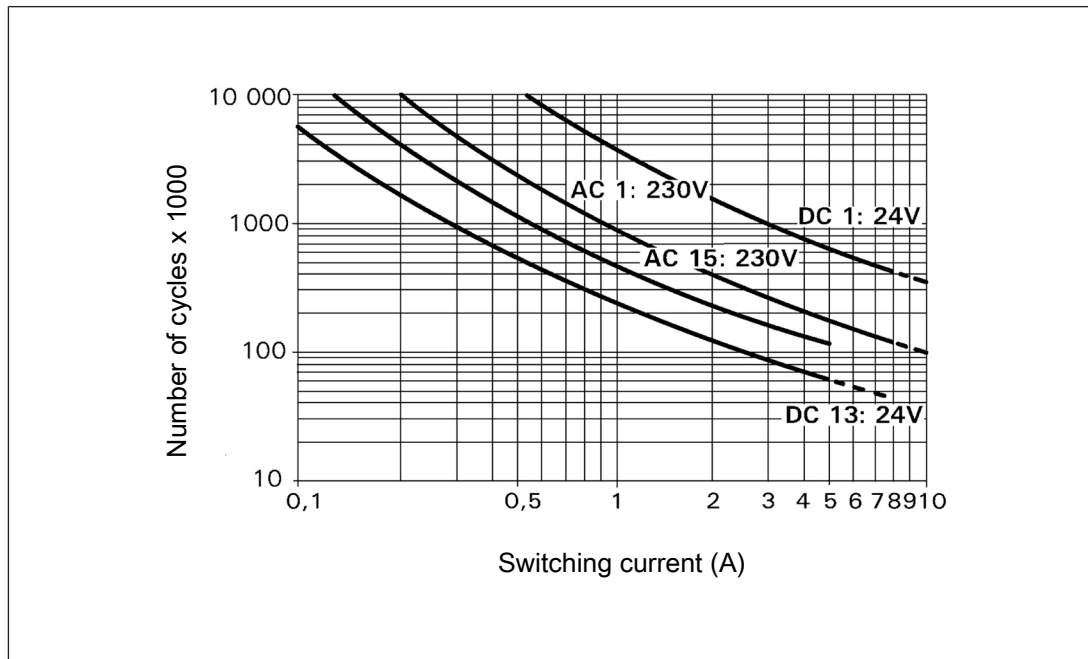

Example

- ▶ Inductive load: 0.2 A
- ▶ Utilisation category: AC15
- ▶ Contact service life: 4 000 000 cycles

Provided the application to be implemented requires fewer than 4 000 000 cycles, the PFH value (see Technical details) can be used in the calculation.

To increase the service life, sufficient spark suppression must be provided on all output contacts. With capacitive loads, any power surges that occur must be noted. With DC contacts, use flywheel diodes for spark suppression.

Safety relays PNOZ X PNOZ X9P

Order reference

| Product type | Features | Connection type | Order no. |
|--------------|----------------------------|-------------------------|-----------|
| PNOZ X9P | 24-240 V AC/DC, 24 V DC | Screw terminals | 777 606 |
| PNOZ X9P C | 24-240 V AC/DC, 24 V DC | Spring-loaded terminals | 787 606 |
| PNOZ X9P | 12 V DC | Screw terminals | 777 607 |
| PNOZ X9P | 24 VDC | Screw terminals | 777 609 |
| PNOZ X9P C | 24 VDC | Spring-loaded terminals | 787 609 |

Safety relays PNOZ X PNOZ X10.11P

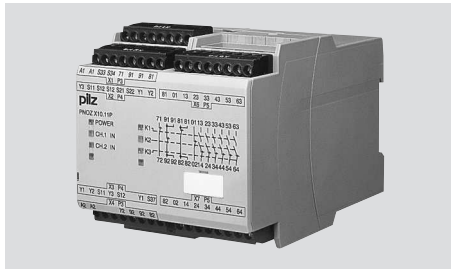

Unit features

- ▶ Positive-guided relay outputs:
 - 6 safety contacts (N/O), instantaneous
 - 4 auxiliary contacts (N/C), instantaneous
- ▶ Connection options for:
 - E-STOP pushbuttons
 - Safety gate limit switches
 - Start buttons
 - Light grids and safety switches with detection of shorts across contacts
- ▶ LED display for:
 - Supply voltage
 - Input state channel 1/2
 - Switch status channel 1/2
 - Switch status start relay
- ▶ Plug-in connection terminals (either spring-loaded terminal or screw terminal)
- ▶ See order reference for unit types

Safety relays PNOZ X PNOZ X10.11P

Block diagram/terminal configuration

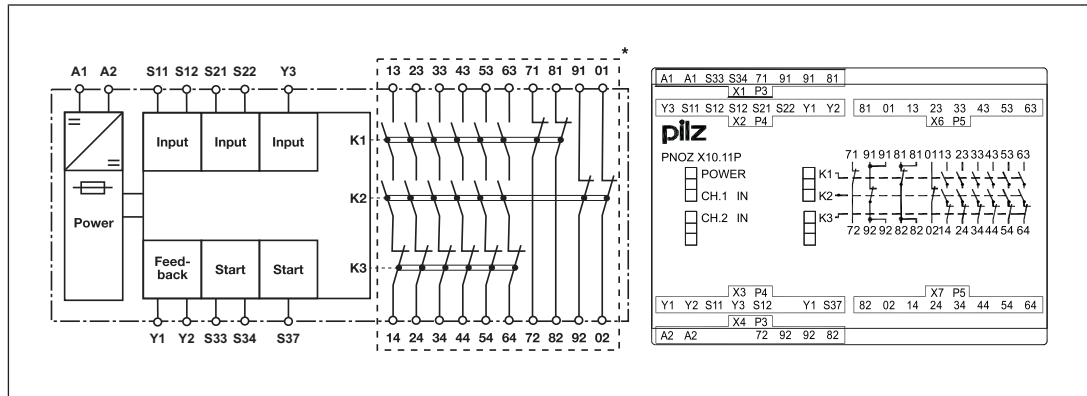

*Insulation between the non-marked area and the relay contacts: Basic insulation (over-voltage category III), Protective separation (overvoltage category II)

Function Description

The safety relay PNOZ X10.11P provides a safety-oriented interruption of a safety circuit. When supply voltage is supplied the "POWER" LED is lit. The unit is ready for operation when the feedback loop Y1-Y2 and the start circuit S12-S34 are closed.

- ▶ Input circuit is closed (e.g. E-STOP pushbutton not operated):
 - LEDs "CH.1 IN", "CH.2 IN" and "K3" go out.
 - LEDs "K1" and "K2" light as soon as relays K1 and K2 are in operating position.
 - LED "K3" goes out as soon as relay K3 is in rest position.
 - Safety contacts 13-14, 23-24, 33-34, 43-44, 53-54 and 63-64 are closed, auxiliary contacts 71-72, 81-82, 91-92 and 01-02 are opened. The unit is active.
- ▶ Input circuit is opened (e.g. E-STOP pushbutton operated):
 - The LEDs "CH.1 IN" and "CH.2 IN" go out.
 - LEDs "K1" and "K2" go out as soon as relays K1 and K2 are in rest position.
 - Safety contacts 13-14, 23-24, 33-34, 43-44, 53-54 and 63-64 are opened redundantly, auxiliary contacts 71-72, 81-82, 91-92 and 01-02 are closed.

Operating modes

- ▶ Single-channel operation: No redundancy in the input circuit, earth faults in the start and input circuit are detected.
- ▶ Dual-channel operation with detection of shorts across contacts: Redundant input circuit, PNOZ X10.11P detects
 - earth faults in the start and input circuit,
 - short circuits in the input circuit,
 - shorts across contacts in the input circuit.

Safety relays PNOZ X PNOZ X10.11P

- ▶ Dual-channel operation without detection of shorts across contacts: Redundant input circuit, detects PNOZ X10.11P
 - earth faults in the start and input circuit,
 - short circuits in the input circuit.
- ▶ Automatic start: Unit is active once the input circuit has been closed.
- ▶ Manual start: Unit is active once the input circuit and the start circuit are closed.
- ▶ Monitored start: Unit is active once
 - the input circuit is closed and then the start circuit is closed and opened again.
 - the start circuit is closed and then opened again once the input circuit is closed.
 The LED "K3" lights when the start circuit is closed and goes out when the start circuit is opened.
- ▶ Increase in the number of available contacts by connecting contact expander modules or external contactors/relays.

Timing diagram

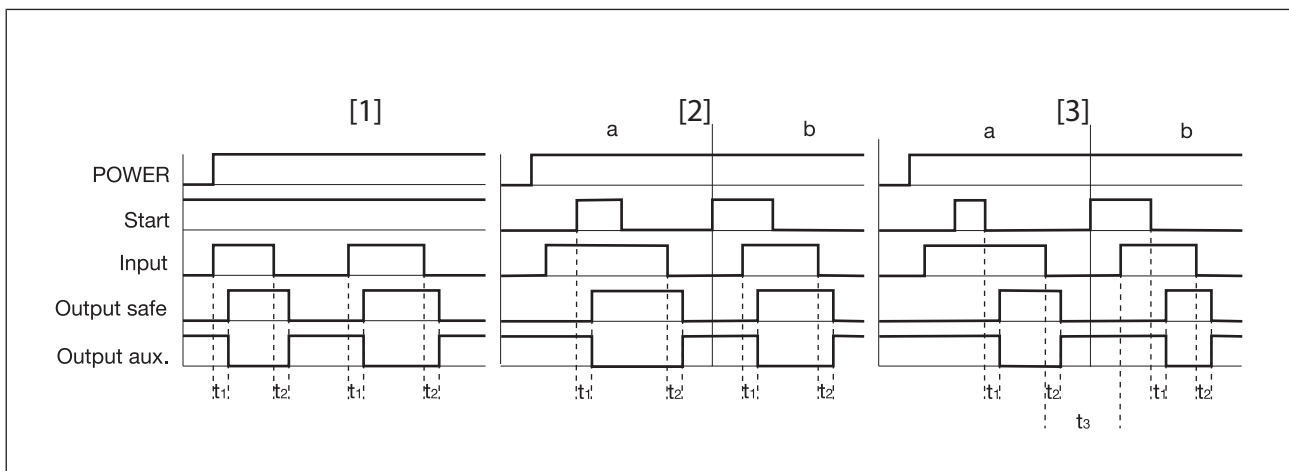

Legend

- ▶ Power: Supply voltage
- ▶ Start: Start circuit
- ▶ Input: Input circuit
- ▶ Output safe: Safety contacts
- ▶ Output aux: Auxiliary contacts
- ▶ [1]: Automatic start
- ▶ [2]: Manual start
- ▶ [3]: Monitored start
- ▶ a: Input circuit closes before start circuit
- ▶ b: Start circuit closes before input circuit

Safety relays PNOZ X PNOZ X10.11P

- ▶ t_1 : Switch-on delay
- ▶ t_2 : Delay-on de-energisation
- ▶ t_3 : Recovery time

Installation

- ▶ The unit should be installed in a control cabinet with a protection type of at least IP54.
- ▶ Use the notch on the rear of the unit to attach it to a DIN rail.
- ▶ Ensure the unit is mounted securely on a vertical DIN rail (35 mm) by using a fixing element (e.g. retaining bracket or an end angle).

Wiring

Please note:

- ▶ Information given in the "[Technical details \[244\]](#)" must be followed.
- ▶ Outputs 13-14, 23-24, 33-34, 43-44, 53-54, 63-64 are safety contacts; outputs 71-72, 81-82, 91-92, 01-02 are auxiliary contacts (e.g. for display).
- ▶ Do **not** use auxiliary contacts 71-72, 81-82, 91-92, 01-02 for safety circuits!
- ▶ Do not connect undesignated terminals.
- ▶ To prevent contact welding, a fuse should be connected before the output contacts (see [Technical details \[244\]](#)).
- ▶ Calculation of the max. cable length l_{\max} in the input circuit:

$$l_{\max} = \frac{R_{l_{\max}}}{R_l / \text{km}}$$

$R_{l_{\max}}$ = max. overall cable resistance (see [Technical details \[244\]](#))

R_l / km = cable resistance/km

- ▶ Use copper wire that can withstand 60/75 °C.
- ▶ Do not switch low currents using contacts that have been used previously with high currents.
- ▶ Sufficient fuse protection must be provided on all output contacts with capacitive and inductive loads.
- ▶ When connecting magnetically operated, reed proximity switches, ensure that the max. peak inrush current (on the input circuit) does not overload the proximity switch.
- ▶ The power supply must comply with the regulations for extra low voltages with protective electrical separation (SELV, PELV) in accordance with VDE 0100, Part 410.
- ▶ Ensure the wiring and EMC requirements of IEC 60204-1 are met.

Safety relays PNOZ X PNOZ X10.11P

Important for detection of shorts across contacts:

As this function for detecting shorts across contacts is not failsafe, it is tested by Pilz during the final control check. If there is a danger of exceeding the cable runs, we recommend the following test after the installation of the device:

1. Unit ready for operation (output contacts closed)
2. Short circuit the test terminals S12, S22 for detecting shorts across the inputs.
3. The unit's fuse must be triggered and the output contacts must open. Cable lengths in the scale of the maximum length can delay the fuse triggering for up to 2 minutes.
4. Reset the fuse: remove the short circuit and switch off the supply voltage for approx. 1 minute.

Preparing for operation

| Supply voltage | AC | DC |
|--|----------------|--------------|
| | | |
| Input circuit | Single-channel | Dual-channel |
| E-STOP without detection of shorts across contacts | | |
| E-STOP with detection of shorts across contacts | | |
| Safety gate without detection of shorts across contacts | | |

Safety relays PNOZ X PNOZ X10.11P

| Input circuit | Single-channel | Dual-channel |
|--|--|---|
| Safety gate with detection of shorts across contacts | | |
| Light guards or safety switch, detection of shorts across contacts via ESPE (only when $U_B = 24\text{ VDC}$) | | |
| Start circuit | Single-channel, dual-channel without detection of shorts across contacts | Dual-channel with detection of shorts across contacts |
| Automatic start | | |
| Automatic start with start-up test | | |
| Manual start | | |
| Monitored start | | |

Safety relays PNOZ X PNOZ X10.11P

| Feedback loop | Without feedback loop monitoring | With feedback loop monitoring |
|---|----------------------------------|-------------------------------|
| Link or contacts from external contactors | | |

Legend

- ▶ S1/S2: E-STOP/safety gate switch
- ▶ S3: Reset button
- ▶ ↑: Switch operated
- ▶ : Gate open
- ▶ : Gate closed

Dimensions in mm

* with spring-loaded terminals

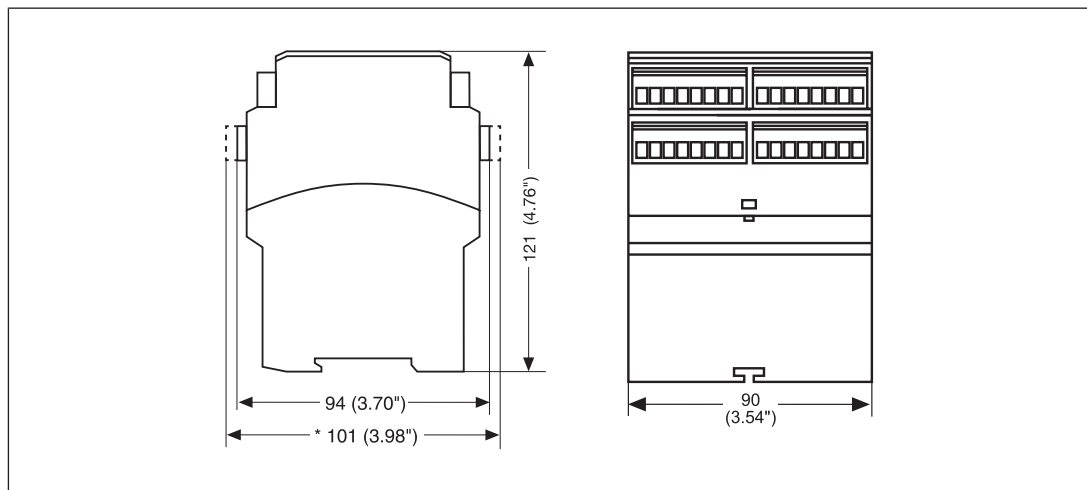

Safety relays PNOZ X PNOZ X10.11P

Technical details

| General | 777750 | 787750 |
|---|--|--|
| Approvals | CCC, CE, EAC (Eurasian), TÜV, cULus Listed | CCC, CE, EAC (Eurasian), TÜV, cULus Listed |
| Electrical data | 777750 | 787750 |
| Supply voltage | | |
| Voltage | 24 V | 24 V |
| Kind | DC | DC |
| Voltage tolerance | -15 %/+10 % | -15 %/+10 % |
| Output of external power supply (DC) | 5,5 W | 5,5 W |
| Residual ripple DC | 160 % | 160 % |
| Duty cycle | 100 % | 100 % |
| Inputs | 777750 | 787750 |
| Number | 2 | 2 |
| Voltage at | | |
| Input circuit DC | 24 V | 24 V |
| Start circuit DC | 24 V | 24 V |
| Feedback loop DC | 24 V | 24 V |
| Current at | | |
| Input circuit DC | 50 mA | 50 mA |
| Start circuit DC | 100 mA | 100 mA |
| Feedback loop DC | 100 mA | 100 mA |
| Min. input resistance at power-on | 89 Ohm | 89 Ohm |
| Max. overall cable resistance RI-max | | |
| Single-channel at UB DC | 45 Ohm | 45 Ohm |
| Dual-channel without detection of shorts across contacts at UB DC | 90 Ohm | 90 Ohm |
| Dual-channel with detection of shorts across contacts at UB DC | 15 Ohm | 15 Ohm |
| Relay outputs | 777750 | 787750 |
| Number of output contacts | | |
| Safety contacts (N/O), instantaneous | 6 | 6 |
| Auxiliary contacts (N/C) | 4 | 4 |
| Max. short circuit current IK | 1 kA | 1 kA |
| Utilisation category | | |
| In accordance with the standard | EN 60947-4-1 | EN 60947-4-1 |

Safety relays PNOZ X PNOZ X10.11P

| Relay outputs | 777750 | 787750 |
|--|-------------------|-------------------|
| Utilisation category of safety contacts | | |
| AC1 at | 240 V | 240 V |
| Min. current | 0,01 A | 0,01 A |
| Max. current | 8 A | 8 A |
| Max. power | 2000 VA | 2000 VA |
| DC1 at | 24 V | 24 V |
| Min. current | 0,01 A | 0,01 A |
| Max. current | 8 A | 8 A |
| Max. power | 200 W | 200 W |
| Utilisation category of auxiliary contacts | | |
| AC1 at | 240 V | 240 V |
| Min. current | 0,01 A | 0,01 A |
| Max. current | 8 A | 8 A |
| Max. power | 2000 VA | 2000 VA |
| DC1 at | 24 V | 24 V |
| Min. current | 0,01 A | 0,01 A |
| Max. current | 8 A | 8 A |
| Max. power | 200 W | 200 W |
| Utilisation category | | |
| In accordance with the standard | EN 60947-5-1 | EN 60947-5-1 |
| Utilisation category of safety contacts | | |
| AC15 at | 230 V | 230 V |
| Max. current | 5 A | 5 A |
| DC13 (6 cycles/min) at | 24 V | 24 V |
| Max. current | 7 A | 7 A |
| Utilisation category of auxiliary contacts | | |
| AC15 at | 230 V | 230 V |
| Max. current | 5 A | 5 A |
| DC13 (6 cycles/min) at | 24 V | 24 V |
| Max. current | 7 A | 7 A |
| Utilisation category in accordance with UL | | |
| Voltage | 240 V AC G. P. | 240 V AC G. P. |
| With current | 8 A | 8 A |
| Voltage | 24 V DC Resistive | 24 V DC Resistive |
| With current | 5 A | 5 A |
| Pilot Duty | B300, R300 | B300, R300 |

Safety relays PNOZ X PNOZ X10.11P

| Relay outputs | 777750 | 787750 |
|--|--------------------------------------|--------------------------------------|
| External contact fuse protection, safety contacts | | |
| In accordance with the standard | EN 60947-5-1 | EN 60947-5-1 |
| Max. melting integral | 240 A²s | 240 A²s |
| Blow-out fuse, quick | 10 A | 10 A |
| Blow-out fuse, slow | 6 A | 6 A |
| Blow-out fuse, gG | 10 A | 10 A |
| Circuit breaker 24V AC/DC, characteristic B/C | 6 A | 6 A |
| External contact fuse protection, auxiliary contacts | | |
| Max. melting integral | 240 A²s | 240 A²s |
| Blow-out fuse, quick | 10 A | 10 A |
| Blow-out fuse, slow | 6 A | 6 A |
| Blow-out fuse, gG | 10 A | 10 A |
| Circuit breaker 24 V AC/DC, characteristic B/C | 6 A | 6 A |
| Contact material | AgSnO₂ + 0,2 µm Au | AgSnO₂ + 0,2 µm Au |
| Conventional thermal current while loading several contacts | 777750 | 787750 |
| I _{th} per contact at UB DC; AC1: 240 V, DC1: 24 V | | |
| Conv. therm. current with 1 contact | 8 A | 8 A |
| Conv. therm. current with 2 contacts | 8 A | 8 A |
| Conv. therm. current with 3 contacts | 8 A | 8 A |
| Conv. therm. current with 4 contacts | 7 A | 7 A |
| Conv. therm. current with 5 contacts | 6 A | 6 A |
| Conv. therm. current with 6 contacts | 5,5 A | 5,5 A |

Safety relays PNOZ X PNOZ X10.11P

| Times | 777750 | 787750 |
|--|--|--|
| Switch-on delay | | |
| With automatic start typ. | 200 ms | 200 ms |
| With automatic start max. | 250 ms | 250 ms |
| With automatic start after power on typ. | 220 ms | 220 ms |
| With automatic start after power on max. | 300 ms | 300 ms |
| With manual start typ. | 200 ms | 200 ms |
| With manual start max. | 250 ms | 250 ms |
| With monitored start typ. | 220 ms | 220 ms |
| With monitored start max. | 260 ms | 260 ms |
| Delay-on de-energisation | | |
| With E-STOP typ. | 20 ms | 20 ms |
| With E-STOP max. | 30 ms | 30 ms |
| With power failure typ. | 360 ms | 360 ms |
| With power failure max. | 480 ms | 480 ms |
| Recovery time at max. switching frequency 1/s | | |
| After E-STOP | 50 ms | 50 ms |
| After power failure | 500 ms | 500 ms |
| Min. start pulse duration with a monitored start | 50 ms | 50 ms |
| Supply interruption before de-energisation | 150 ms | 150 ms |
| Environmental data | 777750 | 787750 |
| Climatic suitability | EN 60068-2-78 | EN 60068-2-78 |
| Ambient temperature | | |
| Temperature range | -10 - 55 °C | -10 - 55 °C |
| Storage temperature | | |
| Temperature range | -40 - 85 °C | -40 - 85 °C |
| Climatic suitability | | |
| Humidity | 93 % r. h. at 40 °C | 93 % r. h. at 40 °C |
| Condensation during operation | Not permitted | Not permitted |
| EMC | EN 60947-5-1, EN 61000-6-2, EN 61326-3-1 | EN 60947-5-1, EN 61000-6-2, EN 61326-3-1 |
| Vibration | | |
| In accordance with the standard | EN 60068-2-6 | EN 60068-2-6 |
| Frequency | 10 - 55 Hz | 10 - 55 Hz |
| Amplitude | 0,35 mm | 0,35 mm |

Safety relays PNOZ X PNOZ X10.11P

| Environmental data | 777750 | 787750 |
|---|--|---|
| Airgap creepage | | |
| In accordance with the standard | EN 60947-1 | EN 60947-1 |
| Overvoltage category | III / II | III / II |
| Pollution degree | 2 | 2 |
| Rated insulation voltage | 250 V | 250 V |
| Rated impulse withstand voltage | 4 kV | 4 kV |
| Protection type | | |
| Mounting area (e.g. control cabinet) | IP54 | IP54 |
| Housing | IP40 | IP40 |
| Terminals | IP20 | IP20 |
| Mechanical data | 777750 | 787750 |
| Mounting position | Any | Any |
| Mechanical life | 10,000,000 cycles | 10,000,000 cycles |
| Material | | |
| Bottom | PPO UL 94 V0 | PPO UL 94 V0 |
| Front | ABS UL 94 V0 | ABS UL 94 V0 |
| Top | PPO UL 94 V0 | PPO UL 94 V0 |
| Connection type | Screw terminal | Spring-loaded terminal |
| Mounting type | plug-in | plug-in |
| Conductor cross section with screw terminals | | |
| 1 core flexible | 0,25 - 2,5 mm ² , 24 - 12 AWG | – |
| 2 core with the same cross section, flexible with crimp connectors, no plastic sleeve | 0,25 - 1 mm ² , 24 - 16 AWG | – |
| 2 core with the same cross section, flexible without crimp connectors or with TWIN crimp connectors | 0,2 - 1,5 mm ² , 24 - 16 AWG | – |
| Torque setting with screw terminals | 0,5 Nm | – |
| Conductor cross section with spring-loaded terminals: Flexible with/without crimp connector | | |
| | – | 0,2 - 1,5 mm ² , 24 - 16 AWG |
| Spring-loaded terminals: Terminal points per connection | | |
| | – | 2 |
| Stripping length with spring-loaded terminals | | |
| | – | 8 mm |
| Dimensions | | |
| Height | 94 mm | 101 mm |
| Width | 90 mm | 90 mm |
| Depth | 121 mm | 121 mm |
| Weight | 580 g | 580 g |

Safety relays PNOZ X PNOZ X10.11P

Where standards are undated, the 2014-07 latest editions shall apply.

Safety characteristic data

| Operating Mode | EN ISO 13849-1: 2015 | EN ISO 13849-1: 2015 | EN 62061 SIL CL | EN 62061 PFH _D [1/h] | IEC 61511 SIL | IEC 61511 PFD | EN ISO 13849-1: 2015 |
|----------------|----------------------|----------------------|-----------------|---------------------------------|---------------|---------------|-----------------------|
| | PL | Category | | | | | T _M [year] |
| – | PL e | Cat. 4 | SIL CL 3 | 2,31E-09 | SIL 3 | 2,03E-06 | 20 |

All the units used within a safety function must be considered when calculating the safety characteristic data.

Supplementary data

The PFH value depends on the switching frequency and the load on the relay output. If the service life graphs are not accessible, the stated PFH value can be used irrespective of the switching frequency and the load, as the PFH value already considers the relay's B10d value as well as the failure rates of the other components.

Safety relays PNOZ X PNOZ X10.11P

Service life graph

The service life graphs indicate the number of cycles from which failures due to wear must be expected. The wear is mainly caused by the electrical load; the mechanical load is negligible.

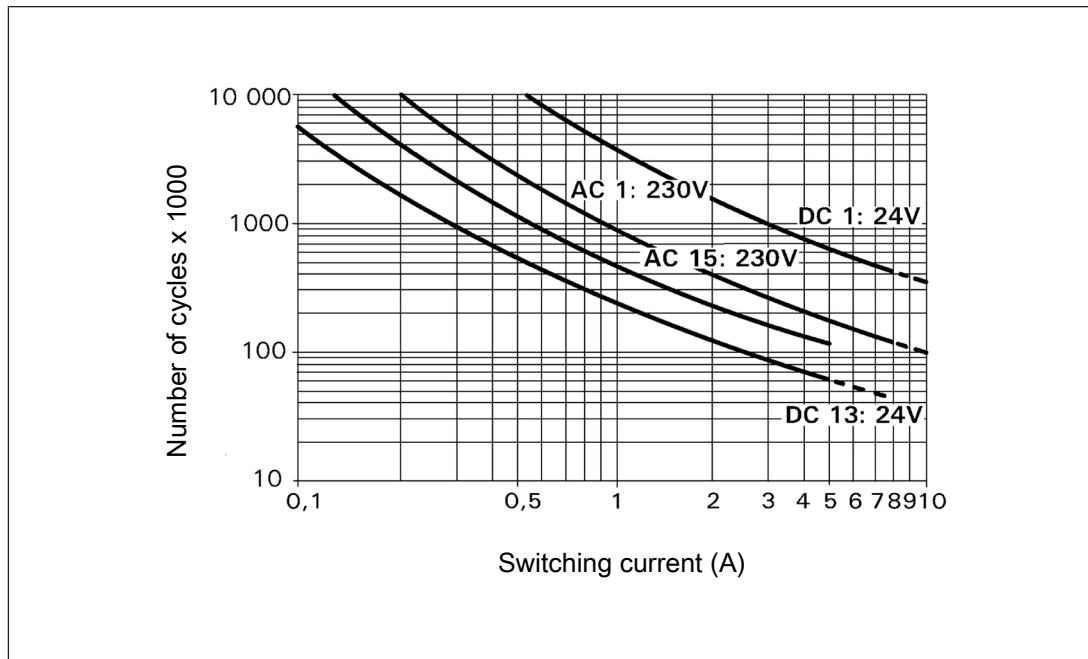

Example

- ▶ Inductive load: 0.2 A
- ▶ Utilisation category: AC15
- ▶ Contact service life: 4 000 000 cycles

Provided the application to be implemented requires fewer than 4 000 000 cycles, the PFH value (see Technical details) can be used in the calculation.

To increase the service life, sufficient spark suppression must be provided on all output contacts. With capacitive loads, any power surges that occur must be noted. With DC contactors, use flywheel diodes for spark suppression.

Order reference

| Product type | Features | Connection type | Order no. |
|----------------|----------|-------------------------|-----------|
| PNOZ X10.11P C | 24 VDC | Spring-loaded terminals | 787 750 |
| PNOZ X10.11P | 24 VDC | Screw terminals | 777 750 |

Safety relays PNOZ X PNOZ X11P

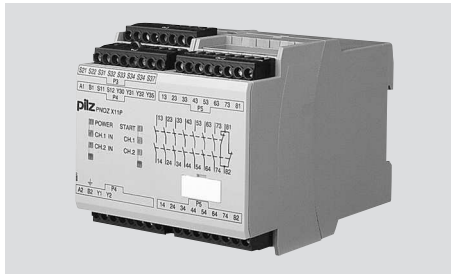

Unit features

- ▶ Positive-guided relay outputs:
 - 7 safety contacts (N/O), instantaneous
 - 1 auxiliary contact (N/C), instantaneous
- ▶ 2 semiconductor outputs
- ▶ Connection options for:
 - E-STOP pushbutton
 - Safety gate limit switch
 - Start button
- ▶ LED indicator for:
 - Supply voltage
 - Input state
 - Switch state of the safety contacts
 - Start circuit
- ▶ Semiconductor outputs signal:
 - Supply voltage is present
 - Switch status of the safety contacts
- ▶ Plug-in connection terminals (either spring-loaded terminal or screw terminal)
- ▶ See order reference for unit types

Safety relays PNOZ X PNOZ X11P

Block diagram/terminal configuration

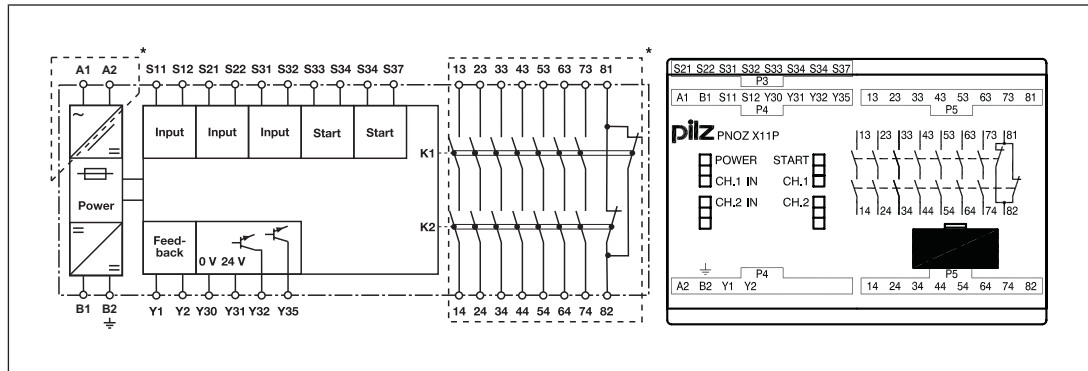

*Insulation between the non-marked area and the relay contacts: Basic insulation (over-voltage category III), Protective separation (overvoltage category II)

Function Description

The safety relay PNOZ X11P provides a safety-oriented interruption of a safety circuit. When supply voltage is supplied the "POWER" LED is lit. The unit is ready for operation when the feedback loop Y1-Y2 and the start circuit S33-S34 are closed. The "START" LED is lit.

- ▶ Input circuit is closed (e.g. E-STOP pushbutton not operated):
 - The LEDs "CH.1 IN" and "CH.2 IN" are lit.
 - The "START" LED goes out.
 - Safety contacts 13-14, 23-24, 33-34, 43-44, 53-54, 63-64 and 73-74 are closed, auxiliary contact 81-82 is opened. The unit is active.
 - The LEDs "CH.1" and "CH.2" are lit.
 - A high signal is present at the semiconductor output switch state Y32.
- ▶ Input circuit is opened (e.g. E-STOP pushbutton operated):
 - The LEDs "CH.1 IN" and "CH.2 IN" go out.
 - Safety contacts 13-14, 23-24, 33-34, 43-44, 53-54, 63-64 and 73-74 are opened redundantly, auxiliary contact 81-82 is closed.
 - The LEDs "CH.1" and "CH.2" go out.
 - A low signal is present at the semiconductor output switch state Y32.

Semiconductor output supply voltage Y35

- ▶ A high signal is present at semi-conductor output Y35 if the supply voltage is present and the internal fuse has not blown.

Safety relays PNOZ X PNOZ X11P

Operating modes

- ▶ Single-channel operation: No redundancy in the input circuit, earth faults in the start and input circuit are detected.
- ▶ Dual-channel operation with detection of shorts across contacts: Redundant input circuit, PNOZ X11P detects
 - earth faults in the start and input circuit,
 - short circuits in the input circuit,
 - shorts across contacts in the input circuit.
- ▶ Automatic start: Unit is active once the input circuit has been closed.
- ▶ Manual start: Unit is active once the input circuit and the start circuit are closed.
- ▶ Monitored start: Unit is active once
 - the input circuit is closed and then the start circuit is closed and opened again.
 - the start circuit is closed and then opened again once the input circuit is closed.
- ▶ Increase in the number of available contacts by connecting contact expander modules or external contactors/relays.

Safety relays PNOZ X PNOZ X11P

Timing diagram

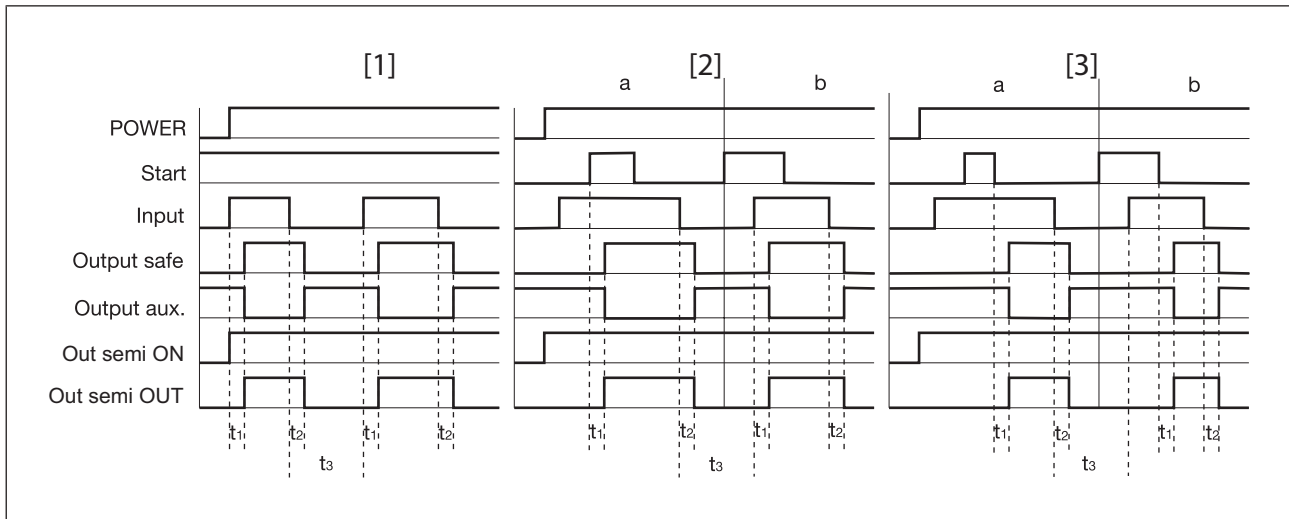

Legend

- ▶ Power: Supply voltage
- ▶ Start: Start circuit
- ▶ Input: Input circuit
- ▶ Output safe: Safety contacts
- ▶ Output aux.: Auxiliary contact
- ▶ Out semi ON: Semiconductor output supply voltage
- ▶ Out semi OUT: Semiconductor output switch state
- ▶ [1]: Automatic start
- ▶ [2]: Manual start
- ▶ [3]: Monitored start
- ▶ a: Input circuit closes before start circuit
- ▶ b: Start circuit closes before input circuit
- ▶ t_1 : Switch-on delay
- ▶ t_2 : Delay-on de-energisation
- ▶ t_3 : Recovery time

Installation

- ▶ The unit should be installed in a control cabinet with a protection type of at least IP54.
- ▶ Use the notch on the rear of the unit to attach it to a DIN rail.
- ▶ Ensure the unit is mounted securely on a vertical DIN rail (35 mm) by using a fixing element (e.g. retaining bracket or an end angle).

Safety relays PNOZ X PNOZ X11P

Wiring

Please note:

- ▶ Information given in the "[Technical details \[📖 259\]](#)" must be followed.
- ▶ Delivery status of units with screw terminals: Link between S11-S12 (dual-channel input circuit) and link between Y1-Y2 (feedback loop)
- ▶ Outputs 13-14, 23-24, 33-34, 43-44, 53-54, 63-64, 73-74 are safety contacts; output 81-82 is an auxiliary contact (e.g. for display).
- ▶ Auxiliary contact 81-82 should **not** be used for safety circuits!
- ▶ Do not connect undesignated terminals.
- ▶ To prevent contact welding, a fuse should be connected before the output contacts (see [Technical details \[📖 259\]](#)).
- ▶ Calculation of the max. cable length l_{\max} in the input circuit:

$$l_{\max} = \frac{R_{l_{\max}}}{R_l / \text{km}}$$

$R_{l_{\max}}$ = max. overall cable resistance (see [Technical details \[📖 259\]](#))

R_l / km = cable resistance/km

- ▶ Use copper wiring with a temperature stability of 75 °C.
- ▶ Do not switch low currents using contacts that have been used previously with high currents.
- ▶ Sufficient fuse protection must be provided on all output contacts with capacitive and inductive loads.
- ▶ When connecting magnetically operated, reed proximity switches, ensure that the max. peak inrush current (on the input circuit) does not overload the proximity switch.
- ▶ With a 24 VDC supply voltage via terminals B1, B2, the power supply must comply with the regulations for extra low voltages with safe electrical separation (SELV, PELV) in accordance with VDE 0100, Part 410.
- ▶ Ensure the wiring and EMC requirements of IEC 60204-1 are met.

Important for detection of shorts across contacts:

As this function for detecting shorts across contacts is not failsafe, it is tested by Pilz during the final control check. If there is a danger of exceeding the cable length, we recommend the following test once the unit is installed:

1. Unit ready for operation (output contacts closed)
2. Short circuit the test terminals S22, S32 for detecting shorts across the inputs.
3. The unit's fuse must be triggered and the output contacts must open. Cable lengths in the scale of the maximum length can delay the fuse triggering for up to 2 minutes.
4. Reset the fuse: Remove the short circuit and switch off the supply voltage for approx. 1 minute.

Safety relays PNOZ X PNOZ X11P

Preparing for operation

| Supply voltage | AC | DC |
|---|----------------|--------------|
| | | |
| Input circuit | Single-channel | Dual-channel |
| E-STOP without detection of shorts across contacts | | |
| E-STOP with detection of shorts across contacts | | |
| Safety gate without detection of shorts across contacts | | |
| Safety gate with detection of shorts across contacts | | |

Safety relays PNOZ X PNOZ X11P



| | E-STOP wiring (single-channel, dual-channel) | |
|---|--|-------------------------------|
| Start circuit | Safety gate (single-channel) | Safety gate (dual-channel) |
| Automatic start | | |
| Automatic start with start-up test | | |
| Manual start | | |
| Monitored start | | |
| Feedback loop | without feedback loop monitoring | with feedback loop monitoring |
| Link or contacts from external contactors | | |

Safety relays PNOZ X PNOZ X11P

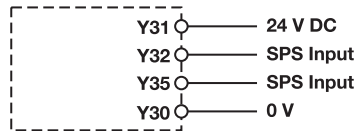
Semiconductor output



Legend

- ▶ S1/S2: E-STOP/safety gate switch
- ▶ S3: Reset button
- ▶ ↑↑: Switch operated
- ▶ : Gate open
- ▶ : Gate closed

Dimensions in mm

* with spring-loaded terminals

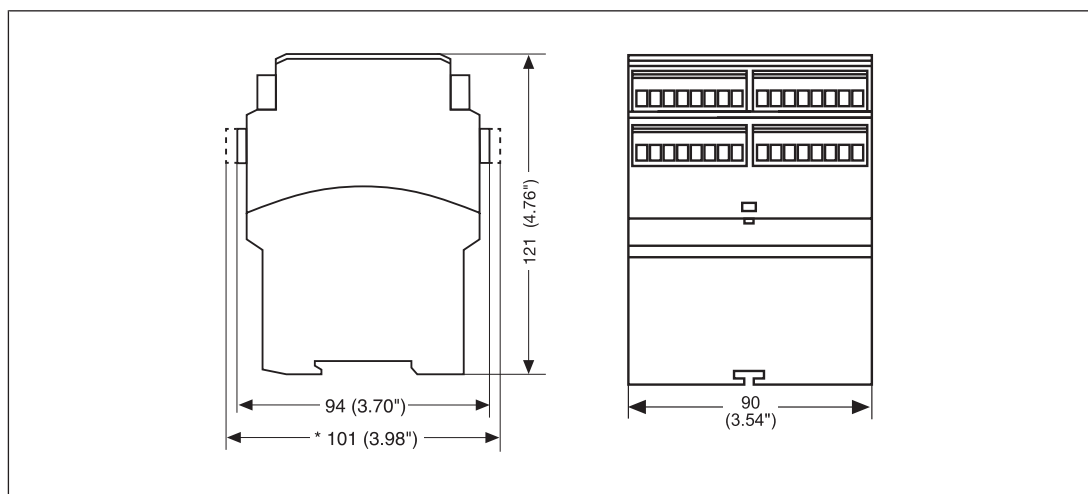

Safety relays PNOZ X PNOZ X11P

Technical details

Order no. 777080 – 777086

See below for more order numbers

| General | 777080 | 777083 | 777086 |
|--------------------------------------|--|--|--|
| Approvals | CCC, CE, EAC (Eurasian), TÜV, cULus Listed | CCC, CE, EAC (Eurasian), TÜV, cULus Listed | CCC, CE, EAC (Eurasian), TÜV, cULus Listed |
| Electrical data | 777080 | 777083 | 777086 |
| Supply voltage | | | |
| Voltage | 24 V | 110 - 120 V | 230 - 240 V |
| Kind | AC | AC | AC |
| Voltage tolerance | -15 %/+10 % | -15 %/+10 % | -15 %/+10 % |
| Output of external power supply (AC) | 9 VA | 9 VA | 9 VA |
| Frequency range AC | 50 - 60 Hz | 50 - 60 Hz | 50 - 60 Hz |
| Supply voltage | | | |
| Voltage | 24 V | 24 V | 24 V |
| Kind | DC | DC | DC |
| Voltage tolerance | -15 %/+10 % | -15 %/+10 % | -15 %/+10 % |
| Output of external power supply (DC) | 3,5 W | 3,5 W | 3,5 W |
| Residual ripple DC | 160 % | 160 % | 160 % |
| Duty cycle | 100 % | 100 % | 100 % |
| Inputs | 777080 | 777083 | 777086 |
| Number | 2 | 2 | 2 |
| Voltage at | | | |
| Input circuit DC | 24 V | 24 V | 24 V |
| Start circuit DC | 24 V | 24 V | 24 V |
| Feedback loop DC | 24 V | 24 V | 24 V |
| Current at | | | |
| Input circuit DC | 50 mA | 50 mA | 50 mA |
| Start circuit DC | 70 mA | 70 mA | 70 mA |
| Feedback loop DC | 70 mA | 70 mA | 70 mA |
| Min. input resistance at power-on | 43 Ohm | 43 Ohm | 43 Ohm |

Safety relays PNOZ X PNOZ X11P

| Inputs | 777080 | 777083 | 777086 |
|--|---------------------|---------------------|---------------------|
| Max. overall cable resistance R _{lmax} | | | |
| Single-channel at UB DC | 50 Ohm | 50 Ohm | 50 Ohm |
| Single-channel at UB AC | 100 Ohm | 100 Ohm | 100 Ohm |
| Dual-channel with detection of shorts across contacts at UB DC | 15 Ohm | 15 Ohm | 15 Ohm |
| Dual-channel with detection of shorts across contacts at UB AC | 20 Ohm | 20 Ohm | 20 Ohm |
| Semiconductor outputs | 777080 | 777083 | 777086 |
| Number | 2 | 2 | 2 |
| Voltage | 24 V | 24 V | 24 V |
| Current | 20 mA | 20 mA | 20 mA |
| External supply voltage | 24 V | 24 V | 24 V |
| Voltage tolerance | -20 %/+20 % | -20 %/+20 % | -20 %/+20 % |
| Relay outputs | 777080 | 777083 | 777086 |
| Number of output contacts | | | |
| Safety contacts (N/O), instantaneous | 7 | 7 | 7 |
| Auxiliary contacts (N/C) | 1 | 1 | 1 |
| Max. short circuit current I _K | 1 kA | 1 kA | 1 kA |
| Utilisation category | | | |
| In accordance with the standard | EN 60947-4-1 | EN 60947-4-1 | EN 60947-4-1 |
| Utilisation category of safety contacts | | | |
| AC1 at | 240 V | 240 V | 240 V |
| Min. current | 0,01 A | 0,01 A | 0,01 A |
| Max. current | 8 A | 8 A | 8 A |
| Max. power | 2000 VA | 2000 VA | 2000 VA |
| DC1 at | 24 V | 24 V | 24 V |
| Min. current | 0,01 A | 0,01 A | 0,01 A |
| Max. current | 8 A | 8 A | 8 A |
| Max. power | 200 W | 200 W | 200 W |

Safety relays PNOZ X PNOZ X11P

| Relay outputs | 777080 | 777083 | 777086 |
|---|----------------------|----------------------|----------------------|
| Utilisation category of auxiliary contacts | | | |
| AC1 at | 240 V | 240 V | 240 V |
| Min. current | 0,01 A | 0,01 A | 0,01 A |
| Max. current | 8 A | 8 A | 8 A |
| Max. power | 2000 VA | 2000 VA | 2000 VA |
| DC1 at | 24 V | 24 V | 24 V |
| Min. current | 0,01 A | 0,01 A | 0,01 A |
| Max. current | 8 A | 8 A | 8 A |
| Max. power | 200 W | 200 W | 200 W |
| Utilisation category | | | |
| In accordance with the standard | EN 60947-5-1 | EN 60947-5-1 | EN 60947-5-1 |
| Utilisation category of safety contacts | | | |
| AC15 at | 230 V | 230 V | 230 V |
| Max. current | 5 A | 5 A | 5 A |
| DC13 (6 cycles/min) at | 24 V | 24 V | 24 V |
| Max. current | 7 A | 7 A | 7 A |
| Utilisation category of auxiliary contacts | | | |
| AC15 at | 230 V | 230 V | 230 V |
| Max. current | 5 A | 5 A | 5 A |
| DC13 (6 cycles/min) at | 24 V | 24 V | 24 V |
| Max. current | 7 A | 7 A | 7 A |
| Utilisation category in accordance with UL | | | |
| Voltage | 240 V AC G. P. | 240 V AC G. P. | 240 V AC G. P. |
| With current | 8 A | 8 A | 8 A |
| Voltage | 24 V DC Resistive | 24 V DC Resistive | 24 V DC Resistive |
| With current | 5 A | 5 A | 5 A |
| Pilot Duty | B300, R300 | B300, R300 | B300, R300 |
| External contact fuse protection, safety contacts | | | |
| In accordance with the standard | EN 60947-5-1 | EN 60947-5-1 | EN 60947-5-1 |
| Max. melting integral | 240 A ² s | 240 A ² s | 240 A ² s |
| Blow-out fuse, quick | 10 A | 10 A | 10 A |
| Blow-out fuse, slow | 6 A | 6 A | 6 A |
| Blow-out fuse, gG | 10 A | 10 A | 10 A |
| Circuit breaker 24V AC/DC, characteristic B/C | 6 A | 6 A | 6 A |

Safety relays PNOZ X PNOZ X11P

| Relay outputs | 777080 | 777083 | 777086 |
|--|--------------------------------------|--------------------------------------|--------------------------------------|
| External contact fuse protection, auxiliary contacts | | | |
| Max. melting integral | 240 A²s | 240 A²s | 240 A²s |
| Blow-out fuse, quick | 10 A | 10 A | 10 A |
| Blow-out fuse, slow | 6 A | 6 A | 6 A |
| Blow-out fuse, gG | 10 A | 10 A | 10 A |
| Circuit breaker 24 V AC/DC, characteristic B/C | 6 A | 6 A | 6 A |
| Contact material | AgSnO₂ + 0,2 µm Au | AgSnO₂ + 0,2 µm Au | AgSnO₂ + 0,2 µm Au |
| Conventional thermal current while loading several contacts | 777080 | 777083 | 777086 |
| I _{th} per contact at UB AC; AC1: 240 V, DC1: 24 V | | | |
| Conv. therm. current with 1 contact | 8 A | 8 A | 8 A |
| Conv. therm. current with 2 contacts | 8 A | 8 A | 8 A |
| Conv. therm. current with 3 contacts | 6,8 A | 6,8 A | 6,8 A |
| Conv. therm. current with 4 contacts | 5,9 A | 5,9 A | 5,9 A |
| Conv. therm. current with 5 contacts | 5,3 A | 5,3 A | 5,3 A |
| Conv. therm. current with 6 contacts | 4,8 A | 4,8 A | 4,8 A |
| Conv. therm. current with 7 contacts | 4,5 A | 4,5 A | 4,5 A |
| I _{th} per contact at UB DC; AC1: 240 V, DC1: 24 V | | | |
| Conv. therm. current with 1 contact | 8 A | 8 A | 8 A |
| Conv. therm. current with 2 contacts | 8 A | 8 A | 8 A |
| Conv. therm. current with 3 contacts | 8 A | 8 A | 8 A |
| Conv. therm. current with 4 contacts | 7,2 A | 7,2 A | 7,2 A |
| Conv. therm. current with 5 contacts | 6,5 A | 6,5 A | 6,5 A |
| Conv. therm. current with 6 contacts | 5,9 A | 5,9 A | 5,9 A |
| Conv. therm. current with 7 contacts | 5,5 A | 5,5 A | 5,5 A |

Safety relays PNOZ X PNOZ X11P

| Times | 777080 | 777083 | 777086 |
|--|--|--|--|
| Switch-on delay | | | |
| With automatic start typ. | 450 ms | 450 ms | 450 ms |
| With automatic start max. | 680 ms | 680 ms | 680 ms |
| With automatic start after power on typ. | 450 ms | 450 ms | 450 ms |
| With automatic start after power on max. | 630 ms | 630 ms | 630 ms |
| With manual start typ. | 450 ms | 450 ms | 450 ms |
| With manual start max. | 680 ms | 680 ms | 680 ms |
| With monitored start typ. | 390 ms | 390 ms | 390 ms |
| With monitored start max. | 550 ms | 550 ms | 550 ms |
| Delay-on de-energisation | | | |
| With E-STOP typ. | 15 ms | 15 ms | 15 ms |
| With E-STOP max. | 30 ms | 30 ms | 30 ms |
| With power failure typ. | 40 ms | 40 ms | 40 ms |
| With power failure max. | 60 ms | 60 ms | 60 ms |
| Recovery time at max. switching frequency 1/s | | | |
| After E-STOP | 50 ms | 50 ms | 50 ms |
| After power failure | 100 ms | 100 ms | 100 ms |
| Min. start pulse duration with a monitored start | 30 ms | 30 ms | 30 ms |
| Supply interruption before de-energisation | 20 ms | 20 ms | 20 ms |
| Simultaneity, channel 1 and 2 max. | ∞ | ∞ | ∞ |
| Environmental data | | | |
| Climatic suitability | EN 60068-2-78 | EN 60068-2-78 | EN 60068-2-78 |
| Ambient temperature | | | |
| Temperature range | -10 - 55 °C | -10 - 55 °C | -10 - 55 °C |
| Storage temperature | | | |
| Temperature range | -40 - 85 °C | -40 - 85 °C | -40 - 85 °C |
| Climatic suitability | | | |
| Humidity | 93 % r. h. at 40 °C | 93 % r. h. at 40 °C | 93 % r. h. at 40 °C |
| Condensation during operation | Not permitted | Not permitted | Not permitted |
| EMC | EN 60947-5-1, EN 61000-6-2, EN 61326-3-1 | EN 60947-5-1, EN 61000-6-2, EN 61326-3-1 | EN 60947-5-1, EN 61000-6-2, EN 61326-3-1 |

Safety relays PNOZ X PNOZ X11P

| Environmental data | 777080 | 777083 | 777086 |
|---|--|--|--|
| Vibration | | | |
| In accordance with the standard | EN 60068-2-6 | EN 60068-2-6 | EN 60068-2-6 |
| Frequency | 10 - 55 Hz | 10 - 55 Hz | 10 - 55 Hz |
| Amplitude | 0,35 mm | 0,35 mm | 0,35 mm |
| Airgap creepage | | | |
| In accordance with the standard | EN 60947-1 | EN 60947-1 | EN 60947-1 |
| Overvoltage category | III / II | III / II | III / II |
| Pollution degree | 2 | 2 | 2 |
| Rated insulation voltage | 250 V | 250 V | 250 V |
| Rated impulse withstand voltage | 4 kV | 4 kV | 4 kV |
| Protection type | | | |
| Mounting area (e.g. control cabinet) | IP54 | IP54 | IP54 |
| Housing | IP40 | IP40 | IP40 |
| Terminals | IP20 | IP20 | IP20 |
| Mechanical data | 777080 | 777083 | 777086 |
| Mounting position | Any | Any | Any |
| Mechanical life | 10,000,000 cycles | 10,000,000 cycles | 10,000,000 cycles |
| Material | | | |
| Bottom | PPO UL 94 V0 | PPO UL 94 V0 | PPO UL 94 V0 |
| Front | ABS UL 94 V0 | ABS UL 94 V0 | ABS UL 94 V0 |
| Top | PPO UL 94 V0 | PPO UL 94 V0 | PPO UL 94 V0 |
| Connection type | Screw terminal | Screw terminal | Screw terminal |
| Mounting type | plug-in | plug-in | plug-in |
| Conductor cross section with screw terminals | | | |
| 1 core flexible | 0,25 - 2,5 mm ² , 24 - 12 AWG | 0,25 - 2,5 mm ² , 24 - 12 AWG | 0,25 - 2,5 mm ² , 24 - 12 AWG |
| 2 core with the same cross section, flexible with crimp connectors, no plastic sleeve | 0,25 - 1 mm ² , 24 - 16 AWG | 0,25 - 1 mm ² , 24 - 16 AWG | 0,25 - 1 mm ² , 24 - 16 AWG |
| 2 core with the same cross section, flexible without crimp connectors or with TWIN crimp connectors | 0,2 - 1,5 mm ² , 24 - 16 AWG | 0,2 - 1,5 mm ² , 24 - 16 AWG | 0,2 - 1,5 mm ² , 24 - 16 AWG |
| Torque setting with screw terminals | 0,5 Nm | 0,5 Nm | 0,5 Nm |

Safety relays PNOZ X PNOZ X11P

| Mechanical data | 777080 | 777083 | 777086 |
|-----------------|--------|--------|--------|
| Dimensions | | | |
| Height | 94 mm | 94 mm | 94 mm |
| Width | 90 mm | 90 mm | 90 mm |
| Depth | 121 mm | 121 mm | 121 mm |
| Weight | 640 g | 640 g | 640 g |

Where standards are undated, the 2014-07 latest editions shall apply.

Order no. 787080 – 787086

| General | 787080 | 787083 | 787086 |
|-----------|--|--|--|
| Approvals | CCC, CE, EAC (Eurasian), TÜV, cULus Listed | CCC, CE, EAC (Eurasian), TÜV, cULus Listed | CCC, CE, EAC (Eurasian), TÜV, cULus Listed |

| Electrical data | 787080 | 787083 | 787086 |
|--------------------------------------|-------------|-------------|-------------|
| Supply voltage | | | |
| Voltage | 24 V | 110 - 120 V | 230 - 240 V |
| Kind | AC | AC | AC |
| Voltage tolerance | -15 %/+10 % | -15 %/+10 % | -15 %/+10 % |
| Output of external power supply (AC) | 9 VA | 9 VA | 9 VA |
| Frequency range AC | 50 - 60 Hz | 50 - 60 Hz | 50 - 60 Hz |

| | | | |
|--------------------------------------|-------------|-------------|-------------|
| Supply voltage | | | |
| Voltage | 24 V | 24 V | 24 V |
| Kind | DC | DC | DC |
| Voltage tolerance | -15 %/+10 % | -15 %/+10 % | -15 %/+10 % |
| Output of external power supply (DC) | 3,5 W | 3,5 W | 3,5 W |
| Residual ripple DC | 160 % | 160 % | 160 % |

| | | | |
|------------|-------|-------|-------|
| Duty cycle | 100 % | 100 % | 100 % |
|------------|-------|-------|-------|

| Inputs | 787080 | 787083 | 787086 |
|--------|--------|--------|--------|
|--------|--------|--------|--------|

| | | | |
|--------|---|---|---|
| Number | 2 | 2 | 2 |
|--------|---|---|---|

| | | | |
|------------------|------|------|------|
| Voltage at | | | |
| Input circuit DC | 24 V | 24 V | 24 V |
| Start circuit DC | 24 V | 24 V | 24 V |
| Feedback loop DC | 24 V | 24 V | 24 V |

| | | | |
|------------------|-------|-------|-------|
| Current at | | | |
| Input circuit DC | 50 mA | 50 mA | 50 mA |
| Start circuit DC | 70 mA | 70 mA | 70 mA |
| Feedback loop DC | 70 mA | 70 mA | 70 mA |

| | | | |
|-----------------------------------|--------|--------|--------|
| Min. input resistance at power-on | 43 Ohm | 43 Ohm | 43 Ohm |
|-----------------------------------|--------|--------|--------|

Safety relays PNOZ X PNOZ X11P

| Inputs | 787080 | 787083 | 787086 |
|--|---------------------|---------------------|---------------------|
| Max. overall cable resistance R _{lmax} | | | |
| Single-channel at UB DC | 50 Ohm | 50 Ohm | 50 Ohm |
| Single-channel at UB AC | 100 Ohm | 100 Ohm | 100 Ohm |
| Dual-channel with detection of shorts across contacts at UB DC | 15 Ohm | 15 Ohm | 15 Ohm |
| Dual-channel with detection of shorts across contacts at UB AC | 20 Ohm | 20 Ohm | 20 Ohm |
| Semiconductor outputs | 787080 | 787083 | 787086 |
| Number | 2 | 2 | 2 |
| Voltage | 24 V | 24 V | 24 V |
| Current | 20 mA | 20 mA | 20 mA |
| External supply voltage | 24 V | 24 V | 24 V |
| Voltage tolerance | -20 %/+20 % | -20 %/+20 % | -20 %/+20 % |
| Relay outputs | 787080 | 787083 | 787086 |
| Number of output contacts | | | |
| Safety contacts (N/O), instantaneous | 7 | 7 | 7 |
| Auxiliary contacts (N/C) | 1 | 1 | 1 |
| Max. short circuit current I _K | 1 kA | 1 kA | 1 kA |
| Utilisation category | | | |
| In accordance with the standard | EN 60947-4-1 | EN 60947-4-1 | EN 60947-4-1 |
| Utilisation category of safety contacts | | | |
| AC1 at | 240 V | 240 V | 240 V |
| Min. current | 0,01 A | 0,01 A | 0,01 A |
| Max. current | 8 A | 8 A | 8 A |
| Max. power | 2000 VA | 2000 VA | 2000 VA |
| DC1 at | 24 V | 24 V | 24 V |
| Min. current | 0,01 A | 0,01 A | 0,01 A |
| Max. current | 8 A | 8 A | 8 A |
| Max. power | 200 W | 200 W | 200 W |

Safety relays PNOZ X PNOZ X11P

| Relay outputs | 787080 | 787083 | 787086 |
|---|---------------------------|---------------------------|---------------------------|
| Utilisation category of auxiliary contacts | | | |
| AC1 at | 240 V | 240 V | 240 V |
| Min. current | 0,01 A | 0,01 A | 0,01 A |
| Max. current | 8 A | 8 A | 8 A |
| Max. power | 2000 VA | 2000 VA | 2000 VA |
| DC1 at | 24 V | 24 V | 24 V |
| Min. current | 0,01 A | 0,01 A | 0,01 A |
| Max. current | 8 A | 8 A | 8 A |
| Max. power | 200 W | 200 W | 200 W |
| Utilisation category | | | |
| In accordance with the standard | EN 60947-5-1 | EN 60947-5-1 | EN 60947-5-1 |
| Utilisation category of safety contacts | | | |
| AC15 at | 230 V | 230 V | 230 V |
| Max. current | 5 A | 5 A | 5 A |
| DC13 (6 cycles/min) at | 24 V | 24 V | 24 V |
| Max. current | 7 A | 7 A | 7 A |
| Utilisation category of auxiliary contacts | | | |
| AC15 at | 230 V | 230 V | 230 V |
| Max. current | 5 A | 5 A | 5 A |
| DC13 (6 cycles/min) at | 24 V | 24 V | 24 V |
| Max. current | 7 A | 7 A | 7 A |
| Utilisation category in accordance with UL | | | |
| Voltage | 240 V AC G. P. | 240 V AC G. P. | 240 V AC G. P. |
| With current | 8 A | 8 A | 8 A |
| Voltage | 24 V DC Resistive | 24 V DC Resistive | 24 V DC Resistive |
| With current | 5 A | 5 A | 5 A |
| Pilot Duty | B300, R300 | B300, R300 | B300, R300 |
| External contact fuse protection, safety contacts | | | |
| In accordance with the standard | EN 60947-5-1 | EN 60947-5-1 | EN 60947-5-1 |
| Max. melting integral | 240 A²s | 240 A²s | 240 A²s |
| Blow-out fuse, quick | 10 A | 10 A | 10 A |
| Blow-out fuse, slow | 6 A | 6 A | 6 A |
| Blow-out fuse, gG | 10 A | 10 A | 10 A |
| Circuit breaker 24V AC/DC, characteristic B/C | 6 A | 6 A | 6 A |

Safety relays PNOZ X PNOZ X11P

| Relay outputs | 787080 | 787083 | 787086 |
|--|--------------------------------------|--------------------------------------|--------------------------------------|
| External contact fuse protection, auxiliary contacts | | | |
| Max. melting integral | 240 A²s | 240 A²s | 240 A²s |
| Blow-out fuse, quick | 10 A | 10 A | 10 A |
| Blow-out fuse, slow | 6 A | 6 A | 6 A |
| Blow-out fuse, gG | 10 A | 10 A | 10 A |
| Circuit breaker 24 V AC/DC, characteristic B/C | 6 A | 6 A | 6 A |
| Contact material | AgSnO₂ + 0,2 µm Au | AgSnO₂ + 0,2 µm Au | AgSnO₂ + 0,2 µm Au |
| Conventional thermal current while loading several contacts | 787080 | 787083 | 787086 |
| I _{th} per contact at UB AC; AC1: 240 V, DC1: 24 V | | | |
| Conv. therm. current with 1 contact | 8 A | 8 A | 8 A |
| Conv. therm. current with 2 contacts | 8 A | 8 A | 8 A |
| Conv. therm. current with 3 contacts | 6,8 A | 6,8 A | 6,8 A |
| Conv. therm. current with 4 contacts | 5,9 A | 5,9 A | 5,9 A |
| Conv. therm. current with 5 contacts | 5,3 A | 5,3 A | 5,3 A |
| Conv. therm. current with 6 contacts | 4,8 A | 4,8 A | 4,8 A |
| Conv. therm. current with 7 contacts | 4,5 A | 4,5 A | 4,5 A |
| I _{th} per contact at UB DC; AC1: 240 V, DC1: 24 V | | | |
| Conv. therm. current with 1 contact | 8 A | 8 A | 8 A |
| Conv. therm. current with 2 contacts | 8 A | 8 A | 8 A |
| Conv. therm. current with 3 contacts | 8 A | 8 A | 8 A |
| Conv. therm. current with 4 contacts | 7,2 A | 7,2 A | 7,2 A |
| Conv. therm. current with 5 contacts | 6,5 A | 6,5 A | 6,5 A |
| Conv. therm. current with 6 contacts | 5,9 A | 5,9 A | 5,9 A |
| Conv. therm. current with 7 contacts | 5,5 A | 5,5 A | 5,5 A |

Safety relays PNOZ X PNOZ X11P

| Times | 787080 | 787083 | 787086 |
|--|--|--|--|
| Switch-on delay | | | |
| With automatic start typ. | 450 ms | 450 ms | 450 ms |
| With automatic start max. | 680 ms | 680 ms | 680 ms |
| With automatic start after power on typ. | 450 ms | 450 ms | 450 ms |
| With automatic start after power on max. | 630 ms | 630 ms | 630 ms |
| With manual start typ. | 450 ms | 450 ms | 450 ms |
| With manual start max. | 680 ms | 680 ms | 680 ms |
| With monitored start typ. | 390 ms | 390 ms | 390 ms |
| With monitored start max. | 550 ms | 550 ms | 550 ms |
| Delay-on de-energisation | | | |
| With E-STOP typ. | 15 ms | 15 ms | 15 ms |
| With E-STOP max. | 30 ms | 30 ms | 30 ms |
| With power failure typ. | 40 ms | 40 ms | 40 ms |
| With power failure max. | 60 ms | 60 ms | 60 ms |
| Recovery time at max. switching frequency 1/s | | | |
| After E-STOP | 50 ms | 50 ms | 50 ms |
| After power failure | 100 ms | 100 ms | 100 ms |
| Min. start pulse duration with a monitored start | 30 ms | 30 ms | 30 ms |
| Supply interruption before de-energisation | 20 ms | 20 ms | 20 ms |
| Simultaneity, channel 1 and 2 max. | ∞ | ∞ | ∞ |
| Environmental data | 787080 | 787083 | 787086 |
| Climatic suitability | EN 60068-2-78 | EN 60068-2-78 | EN 60068-2-78 |
| Ambient temperature | | | |
| Temperature range | -10 - 55 °C | -10 - 55 °C | -10 - 55 °C |
| Storage temperature | | | |
| Temperature range | -40 - 85 °C | -40 - 85 °C | -40 - 85 °C |
| Climatic suitability | | | |
| Humidity | 93 % r. h. at 40 °C | 93 % r. h. at 40 °C | 93 % r. h. at 40 °C |
| Condensation during operation | Not permitted | Not permitted | Not permitted |
| EMC | EN 60947-5-1, EN 61000-6-2, EN 61326-3-1 | EN 60947-5-1, EN 61000-6-2, EN 61326-3-1 | EN 60947-5-1, EN 61000-6-2, EN 61326-3-1 |

Safety relays PNOZ X PNOZ X11P

| Environmental data | 787080 | 787083 | 787086 |
|---|---|---|---|
| Vibration | | | |
| In accordance with the standard | EN 60068-2-6 | EN 60068-2-6 | EN 60068-2-6 |
| Frequency | 10 - 55 Hz | 10 - 55 Hz | 10 - 55 Hz |
| Amplitude | 0,35 mm | 0,35 mm | 0,35 mm |
| Airgap creepage | | | |
| In accordance with the standard | EN 60947-1 | EN 60947-1 | EN 60947-1 |
| Overvoltage category | III / II | III / II | III / II |
| Pollution degree | 2 | 2 | 2 |
| Rated insulation voltage | 250 V | 250 V | 250 V |
| Rated impulse withstand voltage | 4 kV | 4 kV | 4 kV |
| Protection type | | | |
| Mounting area (e.g. control cabinet) | IP54 | IP54 | IP54 |
| Housing | IP40 | IP40 | IP40 |
| Terminals | IP20 | IP20 | IP20 |
| Mechanical data | 787080 | 787083 | 787086 |
| Mounting position | Any | Any | Any |
| Mechanical life | 10,000,000 cycles | 10,000,000 cycles | 10,000,000 cycles |
| Material | | | |
| Bottom | PPO UL 94 V0 | PPO UL 94 V0 | PPO UL 94 V0 |
| Front | ABS UL 94 V0 | ABS UL 94 V0 | ABS UL 94 V0 |
| Top | PPO UL 94 V0 | PPO UL 94 V0 | PPO UL 94 V0 |
| Connection type | Cage clamp terminal | Cage clamp terminal | Cage clamp terminal |
| Mounting type | plug-in | plug-in | plug-in |
| Conductor cross section with spring-loaded terminals: Flexible with/without crimp connector | 0,2 - 1,5 mm ² , 24 - 16 AWG | 0,2 - 1,5 mm ² , 24 - 16 AWG | 0,2 - 1,5 mm ² , 24 - 16 AWG |
| Spring-loaded terminals: Terminal points per connection | 2 | 2 | 2 |
| Stripping length with spring-loaded terminals | 8 mm | 8 mm | 8 mm |
| Dimensions | | | |
| Height | 101 mm | 101 mm | 101 mm |
| Width | 90 mm | 90 mm | 90 mm |
| Depth | 121 mm | 121 mm | 121 mm |
| Weight | 640 g | 640 g | 640 g |

Where standards are undated, the 2014-07 latest editions shall apply.

Safety relays PNOZ X PNOZ X11P

Safety characteristic data

| Operating Mode | EN ISO 13849-1: 2015 | EN ISO 13849-1: 2015 | EN 62061 SIL CL | EN 62061 PFH _D [1/h] | IEC 61511 SIL | IEC 61511 PFD | EN ISO 13849-1: 2015 |
|----------------|----------------------|----------------------|-----------------|---------------------------------|---------------|---------------|-----------------------|
| | PL | Category | | | | | T _M [year] |
| – | PL e | Cat. 4 | SIL CL 3 | 2,31E-09 | SIL 3 | 2,03E-06 | 20 |

All the units used within a safety function must be considered when calculating the safety characteristic data.

Supplementary data

The PFH value depends on the switching frequency and the load on the relay output. If the service life graphs are not accessible, the stated PFH value can be used irrespective of the switching frequency and the load, as the PFH value already considers the relay's B10d value as well as the failure rates of the other components.

Safety relays PNOZ X PNOZ X11P

Service life graph

The service life graphs indicate the number of cycles from which failures due to wear must be expected. The wear is mainly caused by the electrical load; the mechanical load is negligible.

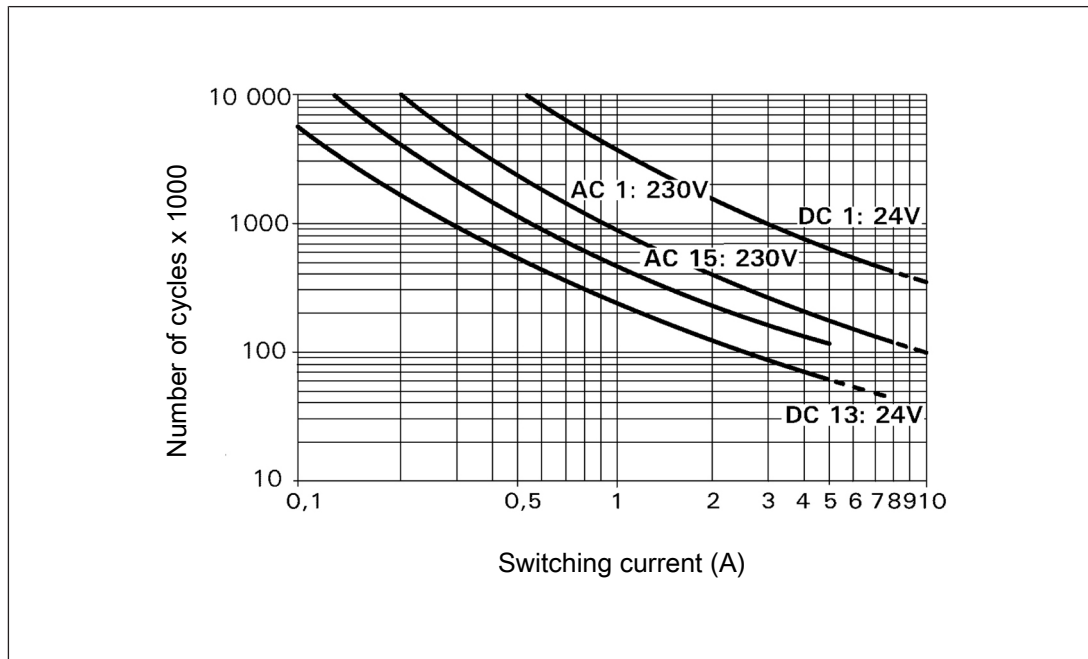

Example

- ▶ Inductive load: 0.2 A
- ▶ Utilisation category: AC15
- ▶ Contact service life: 4 000 000 cycles

Provided the application to be implemented requires fewer than 4 000 000 cycles, the PFH value (see Technical details) can be used in the calculation.

To increase the service life, sufficient spark suppression must be provided on all output contacts. With capacitive loads, any power surges that occur must be noted. With DC contactors, use flywheel diodes for spark suppression.

Order reference

| Product type | Features | Connection type | Order no. |
|--------------|-----------------------|-------------------------|-----------|
| PNOZ X11P | 24 VAC; 24 VDC | Screw terminals | 777 080 |
| PNOZ X11P C | 24 VAC; 24 VDC | Spring-loaded terminals | 787 080 |
| PNOZ X11P | 110 - 120 VAC; 24 VDC | Screw terminals | 777 083 |
| PNOZ X11P C | 110 - 120 VAC; 24 VDC | Spring-loaded terminals | 787 083 |
| PNOZ X11P | 230 - 240 VAC; 24 VDC | Screw terminals | 777 086 |
| PNOZ X11P C | 230 - 240 VAC; 24 VDC | Spring-loaded terminals | 787 086 |

Safety relays PNOZ X PNOZ XV1P



Unit features

- ▶ Positive-guided relay outputs:
 - 2 safety contacts (N/O), instantaneous
 - 1 safety contact (N/O), delay-on de-energisation
- ▶ Connection options for:
 - E-STOP pushbuttons
 - Safety gate limit switches
 - Start buttons
 - Light grids and safety switches with detection of shorts across contacts
- ▶ Selectable delay time
- ▶ LED display for:
 - Supply voltage
 - Switch status of the safety contacts
- ▶ Plug-in connection terminals (either spring-loaded terminal or screw terminal)
- ▶ See order reference for unit types

Safety relays PNOZ X PNOZ XV1P

Block diagram/terminal configuration

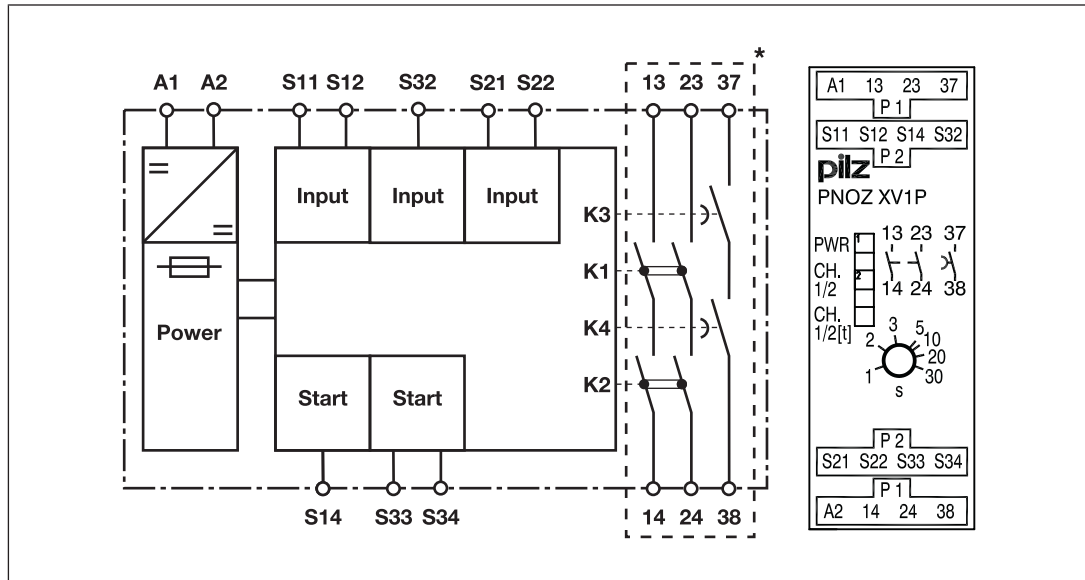

*Insulation between the non-marked area and the relay contacts: Basic insulation (over-voltage category III), Protective separation (overvoltage category II)

Function Description

The safety relay PNOZ XV1P provides a safety-oriented interruption of a safety circuit. When the supply voltage is applied via the E-STOP pushbutton, the "PWR" LED is lit. The unit is ready for operation when the start circuit S11-S14 is closed.

- ▶ Input circuit is closed (e.g. E-STOP pushbutton not operated):
 - The LEDs "CH.1/2" and "CH.1/2[t]" are lit.
 - Safety contacts 13-14, 23-24 and 37-38 are closed, the unit is active.
- ▶ Input circuit is opened (e.g. E-STOP pushbutton operated):
 - Safety contacts 13-14 and 23-24 are redundantly opened.
 - The LED "CH.1/2" goes out.
 - Once the set delay time has elapsed, safety contact 37-38 is opened redundantly.
 - The LED "CH.1/2[t]" goes out.

Before the unit can be restarted, the delay time must have elapsed and the unit must again be ready for operation.

Set delay time:

The delay time for safety contact 37-38 can be set on the front of the unit using a screw-driver.

Safety relays PNOZ X PNOZ XV1P

Operating modes

- ▶ Single-channel operation: No redundancy in the input circuit, earth faults in the start and input circuit are detected.
- ▶ Dual-channel operation without detection of shorts across contacts: Redundant input circuit, detects PNOZ XV1P
 - earth faults in the start and input circuit,
 - short circuits in the input circuit.
- ▶ Dual-channel operation with detection of shorts across contacts: Redundant input circuit, detects PNOZ XV1P
 - earth faults in the start and input circuit,
 - short circuits in the input circuit,
 - Shorts across contacts in the input circuit.
- ▶ Automatic start: Unit is active once the input circuit has been closed.
- ▶ Monitored start: Unit is active once the input circuit is closed and once the start circuit is closed after the waiting period has elapsed (see [Technical details \[279\]](#)).
- ▶ Increase in the number of available contacts by connecting contact expander modules or external contactors/relays.

Timing diagram

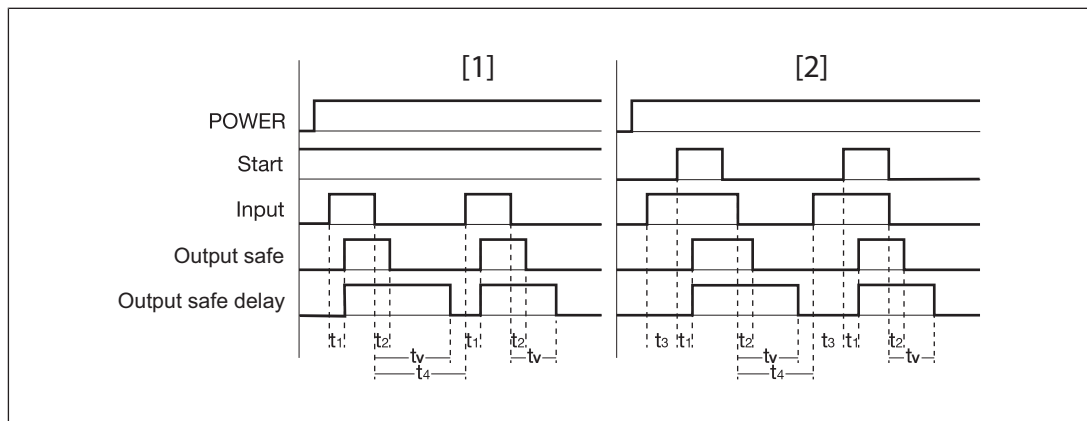

Legend

- ▶ Power: Supply voltage
- ▶ Start: Start circuit
- ▶ Input: Input circuit
- ▶ Output safe: Safety contacts, instantaneous
- ▶ Output safe delay: Delayed safety contact
- ▶ [1]: Automatic start
- ▶ [2]: Monitored start
- ▶ t_1 : Switch-on delay

Safety relays PNOZ X PNOZ XV1P

- ▶ t_2 : Delay-on de-energisation
- ▶ t_3 : Waiting period with a monitored start
- ▶ t_4 : Recovery time
- ▶ t_v : Delay time

Installation

- ▶ The unit should be installed in a control cabinet with a protection type of at least IP54.
- ▶ Use the notch on the rear of the unit to attach it to a DIN rail.
- ▶ Ensure the unit is mounted securely on a vertical DIN rail (35 mm) by using a fixing element (e.g. retaining bracket or an end angle).

Wiring

Please note:

- ▶ Information given in the "[Technical details \[279\]](#)" must be followed.
- ▶ Outputs 13-14, 23-24 are instantaneous safety contacts, output 37-38 is a delay-on de-energisation safety contact.
- ▶ To prevent contact welding, a fuse should be connected before the output contacts (see [Technical details \[279\]](#)).
- ▶ Calculation of the max. cable length l_{\max} in the input circuit:

$$l_{\max} = \frac{R_{l_{\max}}}{R_1 / \text{km}}$$

$R_{l_{\max}}$ = max. overall cable resistance (see [Technical details \[279\]](#))

R_1 / km = cable resistance/km

- ▶ Use copper wire that can withstand 60/75 °C.
- ▶ Sufficient fuse protection must be provided on all output contacts with capacitive and inductive loads.
- ▶ Do not switch low currents using contacts that have been used previously with high currents.
- ▶ The power supply must comply with the regulations for extra low voltages with protective electrical separation (SELV, PELV) in accordance with VDE 0100, Part 410.
- ▶ Ensure the wiring and EMC requirements of IEC 60204-1 are met.

Important for detection of shorts across contacts:

As this function for detecting shorts across contacts is not failsafe, it is tested by Pilz during the final control check. If there is a danger of exceeding the cable length, we recommend the following test once the unit is installed:

1. Unit ready for operation (output contacts closed)
2. Short circuit the test terminals S22, S32 for detecting shorts across the inputs.

Safety relays PNOZ X PNOZ XV1P

3. The unit's fuse must be triggered and the output contacts must open. Cable lengths in the scale of the maximum length can delay the fuse triggering for up to 2 minutes.
4. Reset the fuse: Remove the short circuit and switch off the supply voltage for approx. 1 minute.

Preparing for operation

| Supply voltage | AC | DC |
|---|----------------|--------------|
| | | |
| Input circuit | Single-channel | Dual-channel |
| E-STOP without detection of shorts across contacts | | |
| E-STOP with detection of shorts across contacts | | |
| Safety gate without detection of shorts across contacts | | |
| Safety gate with detection of shorts across contacts | | |

Safety relays PNOZ X PNOZ XV1P

| Input circuit | Single-channel | Dual-channel |
|--|--|--------------------------------|
| Light guard or safety switch, detection of shorts across contacts via ESPE | | |
| Start circuit | E-STOP wiring, safety gate without start-up test | Safety gate with start-up test |
| Automatic start | | |
| Monitored start | | |
| Feedback loop | Automatic start | Monitored start |
| Contacts from external contactors | | |

Legend

- ▶ S1/S2: E-STOP/safety gate switch
- ▶ S3: Reset button
- ▶ ⬆: Switch operated
- ▶ : Gate open
- ▶ : Gate closed

Safety relays PNOZ X PNOZ XV1P

Dimensions in mm

* with spring-loaded terminals

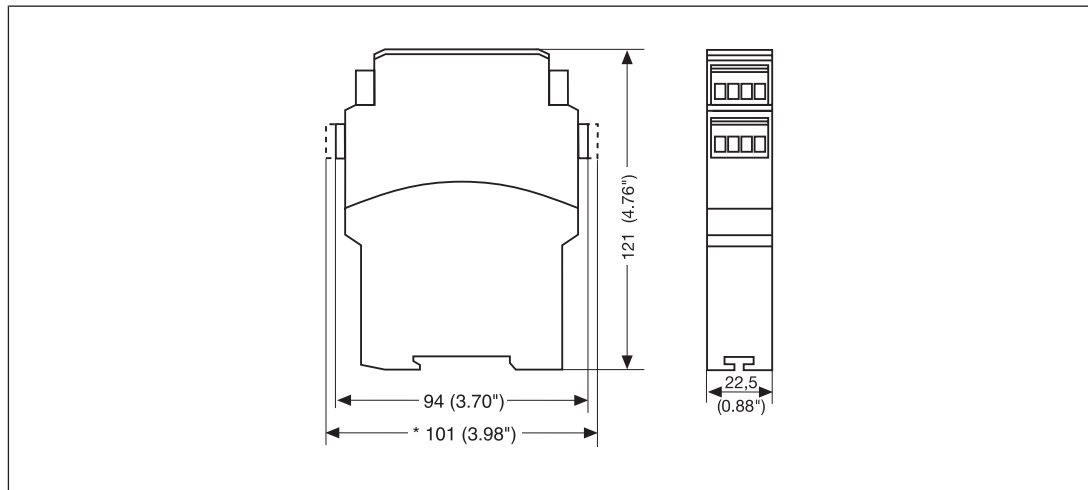

Technical details

Order no. 777601 – 777602

See below for more order numbers

| General | 777601 | 777602 |
|--------------------------------------|--|--|
| Approvals | CCC, CE, EAC (Eurasian), TÜV, cULus Listed | CCC, CE, EAC (Eurasian), TÜV, cULus Listed |
| Electrical data | 777601 | 777602 |
| Supply voltage | | |
| Voltage | 24 V | 24 V |
| Kind | DC | DC |
| Voltage tolerance | -15 %/+10 % | -15 %/+10 % |
| Output of external power supply (DC) | 3,5 W | 3,5 W |
| Residual ripple DC | 20 % | 20 % |
| Duty cycle | 100 % | 100 % |
| Max. inrush current impulse | | |
| Current pulse, A1 | 5 A | 5 A |
| Pulse duration, A1 | 1 ms | 1 ms |
| Inputs | 777601 | 777602 |
| Number | 2 | 2 |
| Voltage at | | |
| Input circuit DC | 24 V | 24 V |
| Start circuit DC | 24 V | 24 V |
| Feedback loop DC | 24 V | 24 V |

Safety relays PNOZ X PNOZ XV1P

| Inputs | 777601 | 777602 |
|---|--------------|--------------|
| Current at | | |
| Input circuit DC | 35 mA | 35 mA |
| Start circuit DC | 35 mA | 35 mA |
| Feedback loop DC | 3,5 mA | 3,5 mA |
| Max. overall cable resistance RI-max | | |
| Single-channel at UB DC | 100 Ohm | 100 Ohm |
| Dual-channel without detection of shorts across contacts at UB DC | 150 Ohm | 150 Ohm |
| Dual-channel with detection of shorts across contacts at UB DC | 15 Ohm | 15 Ohm |
| Relay outputs | 777601 | 777602 |
| Number of output contacts | | |
| Safety contacts (N/O), instantaneous | 2 | 2 |
| Safety contacts (N/O), delayed | 1 | 1 |
| Max. short circuit current IK | 1 kA | 1 kA |
| Utilisation category | | |
| In accordance with the standard | EN 60947-4-1 | EN 60947-4-1 |
| Utilisation category of safety contacts | | |
| AC1 at | 240 V | 240 V |
| Min. current | 0,01 A | 0,01 A |
| Max. current | 5 A | 5 A |
| Max. power | 1250 VA | 1250 VA |
| DC1 at | 24 V | 24 V |
| Min. current | 0,01 A | 0,01 A |
| Max. current | 5 A | 5 A |
| Max. power | 125 W | 125 W |
| Utilisation category of safety contacts delayed | | |
| AC1 at | 240 V | 240 V |
| Min. current | 0,01 A | 0,01 A |
| Max. current | 5 A | 5 A |
| Max. power | 1250 VA | 1250 VA |
| DC1 at | 24 V | 24 V |
| Min. current | 0,01 A | 0,01 A |
| Max. current | 5 A | 5 A |
| Max. power | 125 W | 125 W |
| Utilisation category | | |
| In accordance with the standard | EN 60947-5-1 | EN 60947-5-1 |

Safety relays PNOZ X PNOZ XV1P

| Relay outputs | 777601 | 777602 |
|---|--------------------------------------|--------------------------------------|
| Utilisation category of safety contacts | | |
| AC15 at | 230 V | 230 V |
| Max. current | 1,5 A | 1,5 A |
| DC13 (6 cycles/min) at | 24 V | 24 V |
| Max. current | 2 A | 2 A |
| Utilisation category of safety contacts delayed | | |
| AC15 at | 230 V | 230 V |
| Max. current | 2 A | 2 A |
| DC13 (6 cycles/min) at | 24 V | 24 V |
| Max. current | 4 A | 4 A |
| Utilisation category in accordance with UL | | |
| Voltage | 240 V AC G. P. | 240 V AC G. P. |
| With current | 5 A | 5 A |
| Pilot Duty | C300, R300 | C300, R300 |
| External contact fuse protection, safety contacts | | |
| In accordance with the standard | EN 60947-5-1 | EN 60947-5-1 |
| Max. melting integral | 66 A²s | 66 A²s |
| Blow-out fuse, quick | 6 A | 6 A |
| Blow-out fuse, slow | 4 A | 4 A |
| Blow-out fuse, gG | 6 A | 6 A |
| Circuit breaker 24V AC/DC, characteristic B/C | 4 A | 4 A |
| External contact fuse protection, delayed safety contacts | | |
| Max. melting integral | 66 A²s | 66 A²s |
| Blow-out fuse, quick | 6 A | 6 A |
| Blow-out fuse, slow | 4 A | 4 A |
| Blow-out fuse, gG | 6 A | 6 A |
| Circuit breaker 24 V AC/DC, characteristic B/C | 4 A | 4 A |
| Contact material | AgSnO₂ + 0,2 µm Au | AgSnO₂ + 0,2 µm Au |

Safety relays PNOZ X PNOZ XV1P

| Conventional thermal current while loading several contacts | 777601 | 777602 |
|--|----------------------|----------------------|
| I _{th} per contact at UB DC; AC1: 240 V, DC1: 24 V | | |
| Conv. therm. current with 1 contact | 5 A | 5 A |
| Conv. therm. current with 2 contacts | 3,7 A | 3,7 A |
| Conv. therm. current with 3 contacts | 3 A | 3 A |
| Times | 777601 | 777602 |
| Switch-on delay | | |
| With automatic start typ. | 300 ms | 300 ms |
| With automatic start max. | 550 ms | 550 ms |
| With automatic start after power on typ. | 350 ms | 350 ms |
| With automatic start after power on max. | 750 ms | 750 ms |
| With monitored start typ. | 30 ms | 30 ms |
| With monitored start max. | 60 ms | 60 ms |
| Delay-on de-energisation | | |
| With E-STOP typ. | 15 ms | 15 ms |
| With E-STOP max. | 30 ms | 30 ms |
| With power failure typ. | 100 ms | 100 ms |
| With power failure max. | 150 ms | 150 ms |
| Recovery time at max. switching frequency 1/s | | |
| After E-STOP | 50 ms +tv | 50 ms +tv |
| After power failure | 300 ms | 300 ms |
| Delay time tv | 0,1 - 3 s | 1 - 30 s |
| Time accuracy | -20 %/+20 % | -20 %/+20 % |
| Repetition accuracy | 2 % | 2 % |
| Waiting period with a monitored start | 300 ms | 300 ms |
| Min. start pulse duration with a monitored start | 30 ms | 30 ms |
| Supply interruption before de-energisation | 20 ms | 20 ms |
| Simultaneity, channel 1 and 2 max. | ∞ | ∞ |
| Environmental data | 777601 | 777602 |
| Climatic suitability | EN 60068-2-78 | EN 60068-2-78 |
| Ambient temperature | | |
| Temperature range | -10 - 55 °C | -10 - 55 °C |

Safety relays PNOZ X PNOZ XV1P

| Environmental data | 777601 | 777602 |
|---|---|---|
| Storage temperature | | |
| Temperature range | -40 - 85 °C | -40 - 85 °C |
| Climatic suitability | | |
| Humidity | 93 % r. h. at 40 °C | 93 % r. h. at 40 °C |
| Condensation during operation | Not permitted | Not permitted |
| EMC | EN 60947-5-1, EN 61000-6-2, EN 61000-6-3, EN 61326-3-1 | EN 60947-5-1, EN 61000-6-2, EN 61000-6-3, EN 61326-3-1 |
| Vibration | | |
| In accordance with the standard | EN 60068-2-6 | EN 60068-2-6 |
| Frequency | 10 - 55 Hz | 10 - 55 Hz |
| Amplitude | 0,35 mm | 0,35 mm |
| Airgap creepage | | |
| In accordance with the standard | EN 60947-1 | EN 60947-1 |
| Overvoltage category | III / II | III / II |
| Pollution degree | 2 | 2 |
| Rated insulation voltage | 250 V | 250 V |
| Rated impulse withstand voltage | 4 kV | 4 kV |
| Protection type | | |
| Mounting area (e.g. control cabinet) | IP54 | IP54 |
| Housing | IP40 | IP40 |
| Terminals | IP20 | IP20 |
| Mechanical data | 777601 | 777602 |
| Mounting position | Any | Any |
| Mechanical life | 10,000,000 cycles | 10,000,000 cycles |
| Material | | |
| Bottom | PPO UL 94 V0 | PPO UL 94 V0 |
| Front | ABS UL 94 V0 | ABS UL 94 V0 |
| Top | PPO UL 94 V0 | PPO UL 94 V0 |
| Connection type | Screw terminal | Screw terminal |
| Mounting type | plug-in | plug-in |
| Conductor cross section with screw terminals | | |
| 1 core flexible | 0,25 - 2,5 mm², 24 - 12 AWG | 0,25 - 2,5 mm², 24 - 12 AWG |
| 2 core with the same cross section, flexible with crimp connectors, no plastic sleeve | 0,25 - 1 mm², 24 - 16 AWG | 0,25 - 1 mm², 24 - 16 AWG |
| 2 core with the same cross section, flexible without crimp connectors or with TWIN crimp connectors | 0,2 - 1,5 mm², 24 - 16 AWG | 0,2 - 1,5 mm², 24 - 16 AWG |
| Torque setting with screw terminals | 0,5 Nm | 0,5 Nm |

Safety relays PNOZ X PNOZ XV1P

| Mechanical data | 777601 | 777602 |
|-----------------|---------|---------|
| Dimensions | | |
| Height | 94 mm | 94 mm |
| Width | 22,5 mm | 22,5 mm |
| Depth | 121 mm | 121 mm |
| Weight | 230 g | 230 g |

Where standards are undated, the 2014-07 latest editions shall apply.

Order no. 787601 – 787602

| General | 787601 | 787602 |
|--------------------------------------|--|--|
| Approvals | CCC, CE, EAC (Eurasian), TÜV, cULus Listed | CCC, CE, EAC (Eurasian), TÜV, cULus Listed |
| Electrical data | 787601 | 787602 |
| Supply voltage | | |
| Voltage | 24 V | 24 V |
| Kind | DC | DC |
| Voltage tolerance | -15 %/+10 % | -15 %/+10 % |
| Output of external power supply (DC) | 3,5 W | 3,5 W |
| Residual ripple DC | 20 % | 20 % |
| Duty cycle | 100 % | 100 % |
| Max. inrush current impulse | | |
| Current pulse, A1 | 5 A | 5 A |
| Pulse duration, A1 | 1 ms | 1 ms |
| Inputs | 787601 | 787602 |
| Number | 2 | 2 |
| Voltage at | | |
| Input circuit DC | 24 V | 24 V |
| Start circuit DC | 24 V | 24 V |
| Feedback loop DC | 24 V | 24 V |
| Current at | | |
| Input circuit DC | 35 mA | 35 mA |
| Start circuit DC | 35 mA | 35 mA |
| Feedback loop DC | 3,5 mA | 3,5 mA |

Safety relays PNOZ X PNOZ XV1P

| Inputs | 787601 | 787602 |
|---|--------------|--------------|
| Max. overall cable resistance RI-max | | |
| Single-channel at UB DC | 100 Ohm | 100 Ohm |
| Dual-channel without detection of shorts across contacts at UB DC | 150 Ohm | 150 Ohm |
| Dual-channel with detection of shorts across contacts at UB DC | 15 Ohm | 15 Ohm |
| Relay outputs | 787601 | 787602 |
| Number of output contacts | | |
| Safety contacts (N/O), instantaneous | 2 | 2 |
| Safety contacts (N/O), delayed | 1 | 1 |
| Max. short circuit current IK | 1 kA | 1 kA |
| Utilisation category | | |
| In accordance with the standard | EN 60947-4-1 | EN 60947-4-1 |
| Utilisation category of safety contacts | | |
| AC1 at | 240 V | 240 V |
| Min. current | 0,01 A | 0,01 A |
| Max. current | 5 A | 5 A |
| Max. power | 1250 VA | 1250 VA |
| DC1 at | 24 V | 24 V |
| Min. current | 0,01 A | 0,01 A |
| Max. current | 5 A | 5 A |
| Max. power | 125 W | 125 W |
| Utilisation category of safety contacts delayed | | |
| AC1 at | 240 V | 240 V |
| Min. current | 0,01 A | 0,01 A |
| Max. current | 5 A | 5 A |
| Max. power | 1250 VA | 1250 VA |
| DC1 at | 24 V | 24 V |
| Min. current | 0,01 A | 0,01 A |
| Max. current | 5 A | 5 A |
| Max. power | 125 W | 125 W |
| Utilisation category | | |
| In accordance with the standard | EN 60947-5-1 | EN 60947-5-1 |

Safety relays PNOZ X PNOZ XV1P

| Relay outputs | 787601 | 787602 |
|---|--------------------------------------|--------------------------------------|
| Utilisation category of safety contacts | | |
| AC15 at | 230 V | 230 V |
| Max. current | 1,5 A | 1,5 A |
| DC13 (6 cycles/min) at | 24 V | 24 V |
| Max. current | 2 A | 2 A |
| Utilisation category of safety contacts delayed | | |
| AC15 at | 230 V | 230 V |
| Max. current | 2 A | 2 A |
| DC13 (6 cycles/min) at | 24 V | 24 V |
| Max. current | 4 A | 4 A |
| Utilisation category in accordance with UL | | |
| Voltage | 240 V AC G. P. | 240 V AC G. P. |
| With current | 5 A | 5 A |
| Pilot Duty | C300, R300 | C300, R300 |
| External contact fuse protection, safety contacts | | |
| In accordance with the standard | EN 60947-5-1 | EN 60947-5-1 |
| Max. melting integral | 66 A²s | 66 A²s |
| Blow-out fuse, quick | 6 A | 6 A |
| Blow-out fuse, slow | 4 A | 4 A |
| Blow-out fuse, gG | 6 A | 6 A |
| Circuit breaker 24V AC/DC, characteristic B/C | 4 A | 4 A |
| External contact fuse protection, delayed safety contacts | | |
| Max. melting integral | 66 A²s | 66 A²s |
| Blow-out fuse, quick | 6 A | 6 A |
| Blow-out fuse, slow | 4 A | 4 A |
| Blow-out fuse, gG | 6 A | 6 A |
| Circuit breaker 24 V AC/DC, characteristic B/C | 4 A | 4 A |
| Contact material | AgSnO₂ + 0,2 µm Au | AgSnO₂ + 0,2 µm Au |

Safety relays PNOZ X PNOZ XV1P

| Conventional thermal current while loading several contacts | 787601 | 787602 |
|--|----------------------|----------------------|
| I _{th} per contact at UB DC; AC1: 240 V, DC1: 24 V | | |
| Conv. therm. current with 1 contact | 5 A | 5 A |
| Conv. therm. current with 2 contacts | 3,7 A | 3,7 A |
| Conv. therm. current with 3 contacts | 3 A | 3 A |
| Times | 787601 | 787602 |
| Switch-on delay | | |
| With automatic start typ. | 300 ms | 300 ms |
| With automatic start max. | 550 ms | 550 ms |
| With automatic start after power on typ. | 350 ms | 350 ms |
| With automatic start after power on max. | 750 ms | 750 ms |
| With monitored start typ. | 30 ms | 30 ms |
| With monitored start max. | 60 ms | 60 ms |
| Delay-on de-energisation | | |
| With E-STOP typ. | 15 ms | 15 ms |
| With E-STOP max. | 30 ms | 30 ms |
| With power failure typ. | 100 ms | 100 ms |
| With power failure max. | 150 ms | 150 ms |
| Recovery time at max. switching frequency 1/s | | |
| After E-STOP | 50 ms +tv | 50 ms +tv |
| After power failure | 300 ms | 300 ms |
| Delay time tv | 0,1 - 3 s | 1 - 30 s |
| Time accuracy | -20 %/+20 % | -20 %/+20 % |
| Repetition accuracy | 2 % | 2 % |
| Waiting period with a monitored start | 300 ms | 300 ms |
| Min. start pulse duration with a monitored start | 30 ms | 30 ms |
| Supply interruption before de-energisation | 20 ms | 20 ms |
| Simultaneity, channel 1 and 2 max. | ∞ | ∞ |
| Environmental data | 787601 | 787602 |
| Climatic suitability | EN 60068-2-78 | EN 60068-2-78 |
| Ambient temperature | | |
| Temperature range | -10 - 55 °C | -10 - 55 °C |

Safety relays PNOZ X PNOZ XV1P

| Environmental data | 787601 | 787602 |
|---|---|---|
| Storage temperature | | |
| Temperature range | -40 - 85 °C | -40 - 85 °C |
| Climatic suitability | | |
| Humidity | 93 % r. h. at 40 °C | 93 % r. h. at 40 °C |
| Condensation during operation | Not permitted | Not permitted |
| EMC | EN 60947-5-1, EN 61000-6-2, EN 61000-6-3, EN 61326-3-1 | EN 60947-5-1, EN 61000-6-2, EN 61000-6-3, EN 61326-3-1 |
| Vibration | | |
| In accordance with the standard | EN 60068-2-6 | EN 60068-2-6 |
| Frequency | 10 - 55 Hz | 10 - 55 Hz |
| Amplitude | 0,35 mm | 0,35 mm |
| Airgap creepage | | |
| In accordance with the standard | EN 60947-1 | EN 60947-1 |
| Overvoltage category | III / II | III / II |
| Pollution degree | 2 | 2 |
| Rated insulation voltage | 250 V | 250 V |
| Rated impulse withstand voltage | 4 kV | 4 kV |
| Protection type | | |
| Mounting area (e.g. control cabinet) | IP54 | IP54 |
| Housing | IP40 | IP40 |
| Terminals | IP20 | IP20 |
| Mechanical data | 787601 | 787602 |
| Mounting position | Any | Any |
| Mechanical life | 10,000,000 cycles | 10,000,000 cycles |
| Material | | |
| Bottom | PPO UL 94 V0 | PPO UL 94 V0 |
| Front | ABS UL 94 V0 | ABS UL 94 V0 |
| Top | PPO UL 94 V0 | PPO UL 94 V0 |
| Connection type | Cage clamp terminal | Cage clamp terminal |
| Mounting type | plug-in | plug-in |
| Conductor cross section with spring-loaded terminals: Flexible with/without crimp connector | 0,2 - 1,5 mm², 24 - 16 AWG | 0,2 - 1,5 mm², 24 - 16 AWG |
| Spring-loaded terminals: Terminal points per connection | 2 | 2 |
| Stripping length with spring-loaded terminals | 8 mm | 8 mm |
| Dimensions | | |
| Height | 101 mm | 101 mm |
| Width | 22,5 mm | 22,5 mm |
| Depth | 121 mm | 121 mm |

Safety relays PNOZ X PNOZ XV1P

| Mechanical data | 787601 | 787602 |
|-----------------|--------|--------|
| Weight | 230 g | 230 g |

Where standards are undated, the 2014-07 latest editions shall apply.

Safety characteristic data

| Operating Mode | EN ISO 13849-1: 2015 PL | EN ISO 13849-1: 2015 Category | EN 62061 SIL CL | EN 62061 PFH _D [1/h] | IEC 61511 SIL | IEC 61511 PFD | EN ISO 13849-1: 2015 T _M [year] |
|--------------------------------|----------------------------|----------------------------------|--------------------|------------------------------------|------------------|------------------|---|
| Safety contacts, instantaneous | PL e | Cat. 4 | SIL CL 3 | 2,31E-09 | SIL 3 | 2,03E-06 | 20 |
| Safety contacts, delayed <30 s | PL d | Cat. 3 | SIL CL 3 | 2,64E-09 | SIL 3 | 1,26E-05 | 20 |
| Safety contacts, delayed ≥30 s | PL c | Cat. 1 | SIL CL 1 | 2,87E-09 | SIL 2 | 4,64E-05 | 20 |

All the units used within a safety function must be considered when calculating the safety characteristic data.

Supplementary data

The PFH value depends on the switching frequency and the load on the relay output. If the service life graphs are not accessible, the stated PFH value can be used irrespective of the switching frequency and the load, as the PFH value already considers the relay's B10d value as well as the failure rates of the other components.

Safety relays PNOZ X PNOZ XV1P

Service life graph

The service life graphs indicate the number of cycles from which failures due to wear must be expected. The wear is mainly caused by the electrical load; the mechanical load is negligible.

Service life graph: Safety contacts (N/O), instantaneous

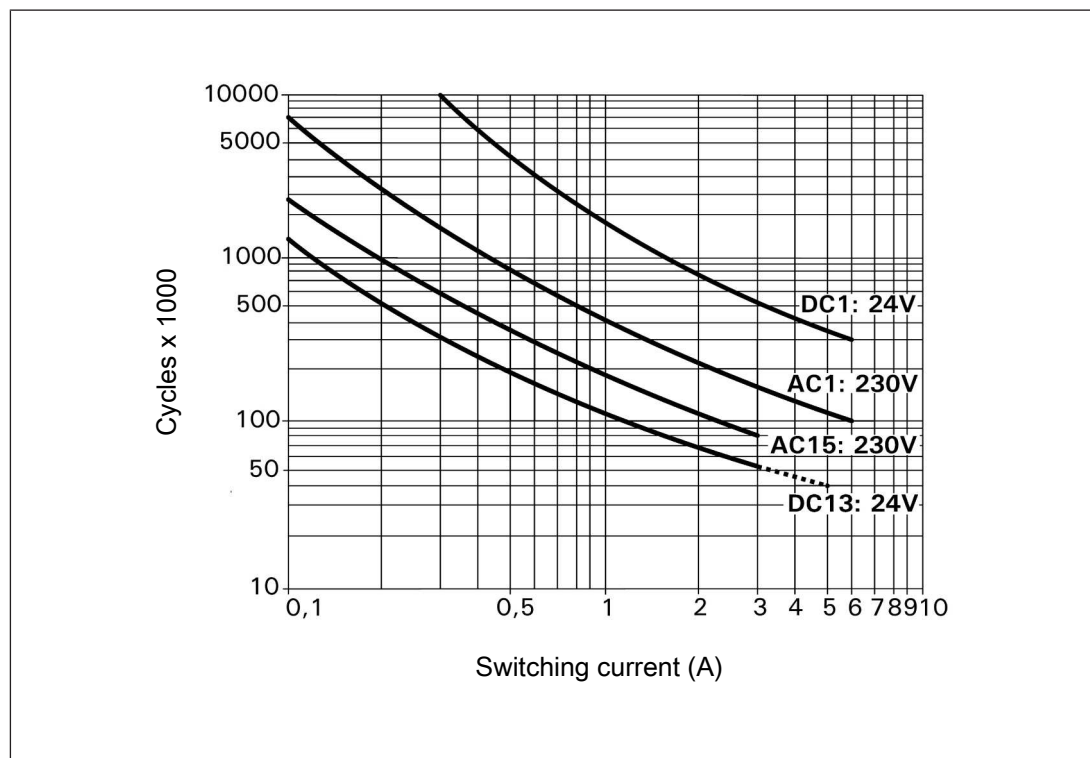

Example

- ▶ Inductive load: 0.2 A
- ▶ Utilisation category: AC15
- ▶ Contact service life: 1 000 000 cycles

Provided the application to be implemented requires fewer than 1 000 000 cycles, the PFH value (see [Technical details \[279\]](#)) can be used in the calculation.

To increase the service life, sufficient spark suppression must be provided on all relay contacts. With capacitive loads, any power surges that occur must be noted. With DC contactors, use flywheel diodes for spark suppression.

Safety relays PNOZ X PNOZ XV1P

Service life graph: Safety contact (N/O), delay-on de-energisation

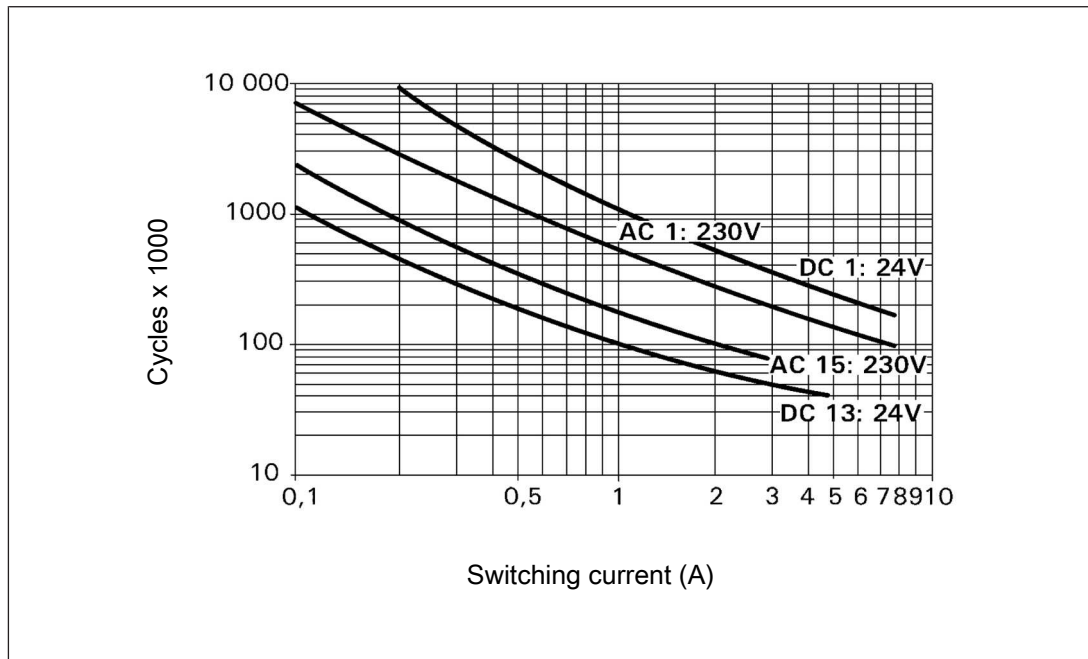

Example

- ▶ Inductive load: 0.2 A,
- ▶ Utilisation category: AC15
- ▶ Contact service life: 900 000 cycles

Provided the application to be implemented requires fewer than 900 000 cycles, the PFH value (see Technical details) can be used in the calculation.

To increase the service life, sufficient spark suppression must be provided on all output contacts. With capacitive loads, any power surges that occur must be noted. With DC contactors, use flywheel diodes for spark suppression.

Order reference

| Product type | Features | Connection type | Order no. |
|--------------|---|-------------------------|-----------|
| PNOZ XV1P | 24 VDC; Delay: up to 3 s selectable | Screw terminals | 777 601 |
| PNOZ XV1P C | 24 VDC; Delay: up to 3 s selectable | Spring-loaded terminals | 787 601 |
| PNOZ XV1P | 24 VDC; Delay: up to 30 s selectable | Screw terminals | 777 602 |
| PNOZ XV1P C | 24 VDC; Delay: up to 30 s selectable | Spring-loaded terminals | 787 602 |

Safety relays PNOZ X PNOZ XV2P

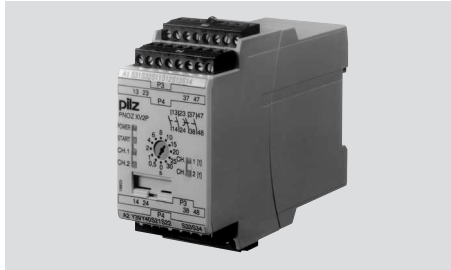

Unit features

- ▶ Positive-guided relay outputs:
 - 2 safety contacts (N/O), instantaneous
 - 2 safety contacts (N/O), delay-on de-energisation
- ▶ Connection options for:
 - E-STOP pushbutton
 - Safety gate limit switch
 - Start button
- ▶ LED display for:
 - Supply voltage
 - Switch state of the safety contacts
 - Start circuit
- ▶ Delay time fixed or selectable
- ▶ Possible to cancel delay time
- ▶ Plug-in connection terminals (either spring-loaded terminal or screw terminal)
- ▶ See order reference for unit types

Safety relays PNOZ X PNOZ XV2P

Block diagram/terminal configuration

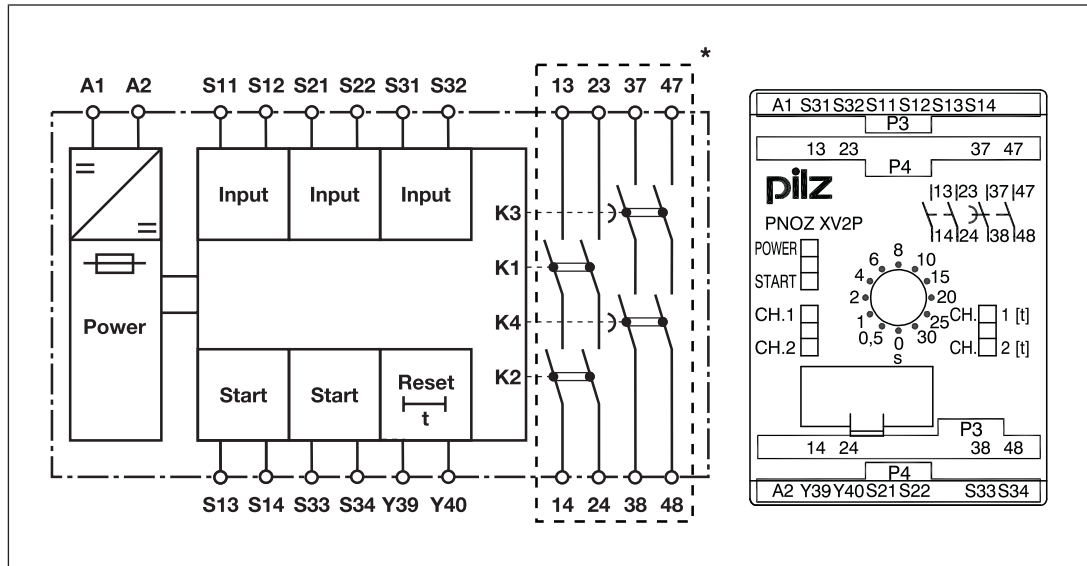

*Insulation between the non-marked area and the relay contacts: Basic insulation (over-voltage category III), Protective separation (overvoltage category II)

Function Description

The safety relay PNOZ XV2P provides a safety-oriented interruption of a safety circuit. When supply voltage is supplied the "POWER" LED is lit. The unit is ready for operation when the reset circuit Y39-Y40 and the start circuit S13-S14 are closed.

- ▶ Input circuit is closed (e.g. E-STOP pushbutton not operated):
 - The "START" LED is lit.
 - The LEDs "CH.1", "CH.1 [t]" and "CH.2", "CH.2 [t]" are lit.
 - The safety contacts 13-14, 23-24, 37-38 and 47-48 are closed. The unit is active.
 - The "START" LED goes out.
- ▶ Input circuit is opened (e.g. E-STOP pushbutton operated):
 - The LEDs "CH.1" and "CH.2" go out.
 - Safety contacts 13-14 and 23-24 are redundantly opened.
 - Safety contacts 37-38 and 47-48 open after the delay time has elapsed.
 - The LEDs "CH.1 [t]" and "CH.2 [t]" go out.

Before the unit can be restarted, the delay time must have elapsed and the unit must again be ready for operation.

Set delay time:

On units with selectable delay time, the delay time of the safety contacts 37-38 and 47-48 can be set on the front of the unit using a screwdriver.

Safety relays PNOZ X PNOZ XV2P

Reset function:

The delay time cycle can be ended prematurely by opening the reset circuit Y39-Y40. For this purpose, one N/C contact is connected between Y39-Y40 instead of a link.

Operating modes

- ▶ Single-channel operation: No redundancy in the input circuit, earth faults in the start and input circuit are detected.
- ▶ Dual-channel operation with detection of shorts across contacts: Redundant input circuit, detects PNOZ XV2P
 - earth faults in the start and input circuit,
 - short circuits in the input circuit,
 - Shorts across contacts in the input circuit.
- ▶ Automatic start: Unit is active once the input circuit has been closed.
- ▶ Monitored start: Unit is active once the input circuit is closed and once the start circuit is closed after the waiting period has elapsed (see [Technical details \[299\]](#)).
- ▶ Increase in the number of available contacts by connecting contact expander modules or external contactors/relays.

Timing diagram

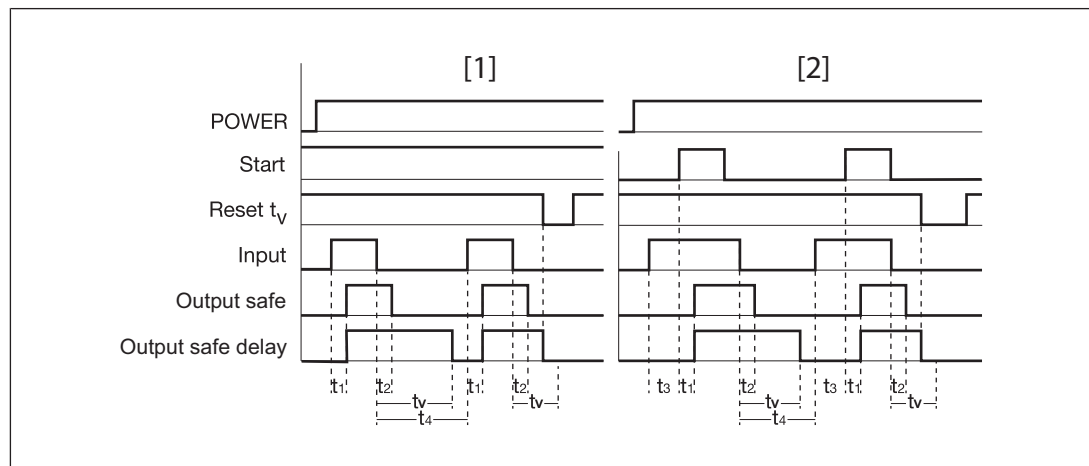

Legend

- ▶ Power: Supply voltage
- ▶ Start: Start circuit
- ▶ Reset t_v : Reset circuit
- ▶ Input: Input circuit
- ▶ Output safe: Safety contacts, instantaneous
- ▶ Output safe delay: Safety contacts, delayed
- ▶ [1]: Automatic start

Safety relays PNOZ X PNOZ XV2P

- ▶ [2]: Monitored start
- ▶ t_1 : Switch-on delay
- ▶ t_2 : Delay-on de-energisation
- ▶ t_3 : Waiting period with a monitored start
- ▶ t_4 : Recovery time
- ▶ t_v : Delay time

Installation

- ▶ The unit should be installed in a control cabinet with a protection type of at least IP54.
- ▶ Use the notch on the rear of the unit to attach it to a DIN rail.
- ▶ Ensure the unit is mounted securely on a vertical DIN rail (35 mm) by using a fixing element (e.g. retaining bracket or an end angle).

Wiring

Please note:

- ▶ Information given in the "[Technical details \[📖 299\]](#)" must be followed.
- ▶ Delivery status of units with screw terminals: Link between S11-S12 (dual-channel input circuit) and link between Y39-Y40 (reset circuit)
- ▶ Outputs 13-14, 23-24 are instantaneous safety contacts, outputs 37-38, 47-48 are delay-on de-energisation safety contacts.
- ▶ Do not connect undesignated terminals.
- ▶ To prevent contact welding, a fuse should be connected before the output contacts (see [Technical details \[📖 299\]](#)).
- ▶ Calculation of the max. cable length l_{\max} in the input circuit:

$$l_{\max} = \frac{R_{l_{\max}}}{R_l / \text{km}}$$

$R_{l_{\max}}$ = max. overall cable resistance (see [Technical details \[📖 299\]](#))

R_l / km = cable resistance/km

- ▶ Use copper wire that can withstand 60/75 °C.
- ▶ Sufficient fuse protection must be provided on all output contacts with capacitive and inductive loads.
- ▶ Do not switch low currents using contacts that have been used previously with high currents.
- ▶ When connecting magnetically operated, reed proximity switches, ensure that the max. peak inrush current (on the input circuit) does not overload the proximity switch.
- ▶ The power supply must comply with the regulations for extra low voltages with protective electrical separation (SELV, PELV) in accordance with VDE 0100, Part 410.
- ▶ Ensure the wiring and EMC requirements of IEC 60204-1 are met.

Safety relays PNOZ X PNOZ XV2P

Important for detection of shorts across contacts:

As this function for detecting shorts across contacts is not failsafe, it is tested by Pilz during the final control check. If there is a danger of exceeding the cable length, we recommend the following test once the unit is installed:

1. Unit ready for operation (output contacts closed)
2. Short circuit the test terminals S22, S32 for detecting shorts across the inputs.
3. The unit's fuse must be triggered and the output contacts must open. Cable lengths in the scale of the maximum length can delay the fuse triggering for up to 2 minutes.
4. Reset the fuse: Remove the short circuit and switch off the supply voltage for approx. 1 minute.

Preparing for operation

| Supply voltage | AC | DC |
|---|----------------|--------------|
| | | |
| Input circuit | Single-channel | Dual-channel |
| E-STOP without detection of shorts across contacts | | |
| E-STOP with detection of shorts across contacts | | |
| Safety gate without detection of shorts across contacts | | |

Safety relays PNOZ X PNOZ XV2P

| Input circuit | Single-channel | Dual-channel |
|---|--|--------------------------------|
| Safety gate with detection of shorts across contacts | | |
| Start circuit | E-STOP wiring Safety gate without start-up test | Safety gate with start-up test |
| Automatic start | | |
| Monitored start | | |
| Reset delay time | Without reset | With reset |
| Link or N/C contact | | |

Safety relays PNOZ X PNOZ XV2P

| Feedback loop | Automatic start | Monitored start |
|-----------------------------------|-----------------|-----------------|
| Contacts from external contactors | | |

Legend

- ▶ S1/S2: E-STOP/safety gate switch
- ▶ S3: Reset button
- ▶ ⬆: Switch operated
- ▶ : Gate open
- ▶ : Gate closed

Dimensions in mm

* with spring-loaded terminals

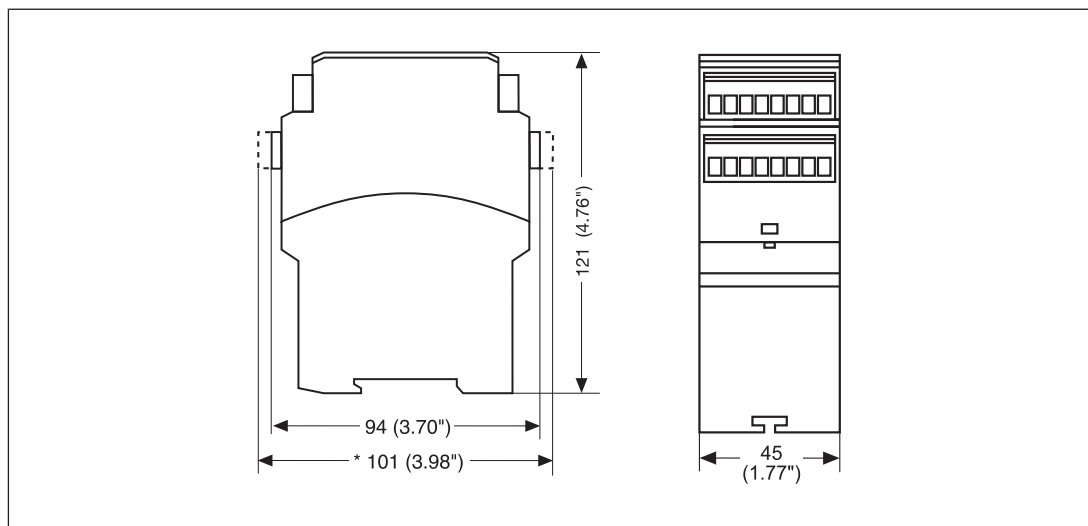

Safety relays PNOZ X PNOZ XV2P

Technical details

Order no. 777500 – 777503

See below for more order numbers

| General | 777500 | 777502 | 777503 |
|--|--|--|--|
| Approvals | CCC, CE, EAC (Eurasian), TÜV, cULus Listed | CCC, CE, EAC (Eurasian), TÜV, cULus Listed | CCC, CE, EAC (Eurasian), TÜV, cULus Listed |
| Electrical data | 777500 | 777502 | 777503 |
| Supply voltage | | | |
| Voltage | 24 V | 24 V | 24 V |
| Kind | DC | DC | DC |
| Voltage tolerance | -15 %/+10 % | -15 %/+10 % | -15 %/+10 % |
| Output of external power supply (DC) | 4,5 W | 4,5 W | 4,5 W |
| Residual ripple DC | 160 % | 160 % | 160 % |
| Duty cycle | 100 % | 100 % | 100 % |
| Max. inrush current impulse | | | |
| Current pulse, A1 | 5 A | 5 A | 5 A |
| Pulse duration, A1 | 1 ms | 1 ms | 1 ms |
| Inputs | 777500 | 777502 | 777503 |
| Number | 2 | 2 | 2 |
| Voltage at | | | |
| Input circuit DC | 24 V | 24 V | 24 V |
| Start circuit DC | 24 V | 24 V | 24 V |
| Feedback loop DC | 24 V | 24 V | 24 V |
| Current at | | | |
| Input circuit DC | 35 mA | 35 mA | 35 mA |
| Start circuit DC | 40 mA | 40 mA | 40 mA |
| Feedback loop DC | 3,5 mA | 3,5 mA | 3,5 mA |
| Min. input resistance at power-on | 143 Ohm | 143 Ohm | 143 Ohm |
| Max. overall cable resistance R _{lmax} | | | |
| Single-channel at UB DC | 100 Ohm | 100 Ohm | 100 Ohm |
| Dual-channel with detection of shorts across contacts at UB DC | 10 Ohm | 10 Ohm | 10 Ohm |

Safety relays PNOZ X PNOZ XV2P

| Relay outputs | 777500 | 777502 | 777503 |
|---|--------------|--------------|--------------|
| Number of output contacts | | | |
| Safety contacts (N/O), instantaneous | 2 | 2 | 2 |
| Safety contacts (N/O), delayed | 2 | 2 | 2 |
| Max. short circuit current IK | 1 kA | 1 kA | 1 kA |
| Utilisation category | | | |
| In accordance with the standard | EN 60947-4-1 | EN 60947-4-1 | EN 60947-4-1 |
| Utilisation category of safety contacts | | | |
| AC1 at | 240 V | 240 V | 240 V |
| Min. current | 0,01 A | 0,01 A | 0,01 A |
| Max. current | 8 A | 8 A | 8 A |
| Max. power | 2000 VA | 2000 VA | 2000 VA |
| DC1 at | 24 V | 24 V | 24 V |
| Min. current | 0,01 A | 0,01 A | 0,01 A |
| Max. current | 8 A | 8 A | 8 A |
| Max. power | 200 W | 200 W | 200 W |
| Utilisation category of safety contacts delayed | | | |
| AC1 at | 240 V | 240 V | 240 V |
| Min. current | 0,01 A | 0,01 A | 0,01 A |
| Max. current | 8 A | 8 A | 8 A |
| Max. power | 2000 VA | 2000 VA | 2000 VA |
| DC1 at | 24 V | 24 V | 24 V |
| Min. current | 0,01 A | 0,01 A | 0,01 A |
| Max. current | 8 A | 8 A | 8 A |
| Max. power | 200 W | 200 W | 200 W |
| Utilisation category | | | |
| In accordance with the standard | EN 60947-5-1 | EN 60947-5-1 | EN 60947-5-1 |
| Utilisation category of safety contacts | | | |
| AC15 at | 230 V | 230 V | 230 V |
| Max. current | 5 A | 5 A | 5 A |
| DC13 (6 cycles/min) at | 24 V | 24 V | 24 V |
| Max. current | 7 A | 7 A | 7 A |

Safety relays PNOZ X PNOZ XV2P

| Relay outputs | 777500 | 777502 | 777503 |
|---|--------------------------------------|--------------------------------------|--------------------------------------|
| Utilisation category of safety contacts delayed | | | |
| AC15 at | 230 V | 230 V | 230 V |
| Max. current | 5 A | 5 A | 5 A |
| DC13 (6 cycles/min) at | 24 V | 24 V | 24 V |
| Max. current | 7 A | 7 A | 7 A |
| Utilisation category in accordance with UL | | | |
| Voltage | 240 V AC G. P. | 240 V AC G. P. | 240 V AC G. P. |
| With current | 8 A | 8 A | 8 A |
| Pilot Duty | C300, R300 | C300, R300 | C300, R300 |
| External contact fuse protection, safety contacts | | | |
| In accordance with the standard | EN 60947-5-1 | EN 60947-5-1 | EN 60947-5-1 |
| Max. melting integral | 240 A²s | 240 A²s | 240 A²s |
| Blow-out fuse, quick | 10 A | 10 A | 10 A |
| Blow-out fuse, slow | 6 A | 6 A | 6 A |
| Blow-out fuse, gG | 10 A | 10 A | 10 A |
| Circuit breaker 24V AC/DC, characteristic B/C | 6 A | 6 A | 6 A |
| External contact fuse protection, delayed safety contacts | | | |
| Max. melting integral | 240 A²s | 240 A²s | 240 A²s |
| Blow-out fuse, quick | 10 A | 10 A | 10 A |
| Blow-out fuse, slow | 6 A | 6 A | 6 A |
| Blow-out fuse, gG | 10 A | 10 A | 10 A |
| Circuit breaker 24 V AC/DC, characteristic B/C | 6 A | 6 A | 6 A |
| Contact material | AgSnO₂ + 0,2 µm Au | AgSnO₂ + 0,2 µm Au | AgSnO₂ + 0,2 µm Au |

Safety relays PNOZ X PNOZ XV2P

| Conventional thermal current while loading several contacts | 777500 | 777502 | 777503 |
|---|---|--|--------------------|
| Ith per contact at UB DC; AC1: 240 V, DC1: 24 V | | | |
| Conv. therm. current with 1 contact | 8 A | 8 A | 8 A |
| Conv. therm. current with 2 contacts | 7 A | 7 A | 7 A |
| Conv. therm. current with 3 contacts | 5,7 A | 5,7 A | 5,7 A |
| Conv. therm. current with 4 contacts | 5 A | 5 A | 5 A |
| Times | 777500 | 777502 | 777503 |
| Switch-on delay | | | |
| With automatic start typ. | 350 ms | 350 ms | 350 ms |
| With automatic start max. | 650 ms | 650 ms | 650 ms |
| With automatic start after power on typ. | 385 ms | 385 ms | 385 ms |
| With automatic start after power on max. | 700 ms | 700 ms | 700 ms |
| With monitored start typ. | 35 ms | 35 ms | 35 ms |
| With monitored start max. | 70 ms | 70 ms | 70 ms |
| Delay-on de-energisation | | | |
| With E-STOP typ. | 15 ms | 15 ms | 15 ms |
| With E-STOP max. | 30 ms | 30 ms | 30 ms |
| With power failure typ. | 85 ms | 85 ms | 85 ms |
| With power failure max. | 200 ms | 200 ms | 200 ms |
| Recovery time at max. switching frequency 1/s | | | |
| After E-STOP | 50 ms +tv | 50 ms +tv | 50 ms +tv |
| After power failure | 250 ms | 250 ms | 250 ms |
| Delay time tv | 0,1 s, 0,5 s, 1 s, 2 s, 4 s, 6 s, 8 s, 10 s, 15 s, 20 s, 25 s, 30 s | 0,1 s, 0,2 s, 0,3 s, 0,4 s, 0,5 s, 0,6 s, 0,7 s, 0,8 s, 1 s, 1,5 s, 2 s, 3 s | 1 s |
| Time accuracy | -15 %/+15 % +50 ms | -15 %/+15 % +50 ms | -15 %/+15 % +50 ms |
| Repetition accuracy | 2 % | 2 % | 2 % |
| Waiting period with a monitored start | 300 ms | 300 ms | 300 ms |
| Min. start pulse duration with a monitored start | 30 ms | 30 ms | 30 ms |

Safety relays PNOZ X PNOZ XV2P

| Times | 777500 | 777502 | 777503 |
|--|--|--|--|
| Supply interruption before de-energisation | 20 ms | 20 ms | 20 ms |
| Simultaneity, channel 1 and 2 max. | ∞ | ∞ | ∞ |
| Environmental data | 777500 | 777502 | 777503 |
| Climatic suitability | EN 60068-2-78 | EN 60068-2-78 | EN 60068-2-78 |
| Ambient temperature | | | |
| Temperature range | -10 - 55 °C | -10 - 55 °C | -10 - 55 °C |
| Storage temperature | | | |
| Temperature range | -40 - 85 °C | -40 - 85 °C | -40 - 85 °C |
| Climatic suitability | | | |
| Humidity | 93 % r. h. at 40 °C | 93 % r. h. at 40 °C | 93 % r. h. at 40 °C |
| Condensation during operation | Not permitted | Not permitted | Not permitted |
| EMC | EN 60947-5-1, EN 61000-6-2, EN 61326-3-1 | EN 60947-5-1, EN 61000-6-2, EN 61326-3-1 | EN 60947-5-1, EN 61000-6-2, EN 61326-3-1 |
| Vibration | | | |
| In accordance with the standard | EN 60068-2-6 | EN 60068-2-6 | EN 60068-2-6 |
| Frequency | 10 - 55 Hz | 10 - 55 Hz | 10 - 55 Hz |
| Amplitude | 0,35 mm | 0,35 mm | 0,35 mm |
| Airgap creepage | | | |
| In accordance with the standard | EN 60947-1 | EN 60947-1 | EN 60947-1 |
| Overvoltage category | III / II | III / II | III / II |
| Pollution degree | 2 | 2 | 2 |
| Rated insulation voltage | 250 V | 250 V | 250 V |
| Rated impulse withstand voltage | 4 kV | 4 kV | 4 kV |
| Protection type | | | |
| Mounting area (e.g. control cabinet) | IP54 | IP54 | IP54 |
| Housing | IP40 | IP40 | IP40 |
| Terminals | IP20 | IP20 | IP20 |
| Mechanical data | 777500 | 777502 | 777503 |
| Mounting position | Any | Any | Any |
| Mechanical life | 10,000,000 cycles | 10,000,000 cycles | 10,000,000 cycles |
| Material | | | |
| Bottom | PPO UL 94 V0 | PPO UL 94 V0 | PPO UL 94 V0 |
| Front | ABS UL 94 V0 | ABS UL 94 V0 | ABS UL 94 V0 |
| Top | PPO UL 94 V0 | PPO UL 94 V0 | PPO UL 94 V0 |
| Connection type | Screw terminal | Screw terminal | Screw terminal |

Safety relays PNOZ X PNOZ XV2P

| Mechanical data | 777500 | 777502 | 777503 |
|---|--|--|--|
| Mounting type | plug-in | plug-in | plug-in |
| Conductor cross section with screw terminals | | | |
| 1 core flexible | 0,25 - 2,5 mm ² , 24 - 12 AWG | 0,25 - 2,5 mm ² , 24 - 12 AWG | 0,25 - 2,5 mm ² , 24 - 12 AWG |
| 2 core with the same cross section, flexible with crimp connectors, no plastic sleeve | 0,25 - 1 mm ² , 24 - 16 AWG | 0,25 - 1 mm ² , 24 - 16 AWG | 0,25 - 1 mm ² , 24 - 16 AWG |
| 2 core with the same cross section, flexible without crimp connectors or with TWIN crimp connectors | 0,2 - 1,5 mm ² , 24 - 16 AWG | 0,2 - 1,5 mm ² , 24 - 16 AWG | 0,2 - 1,5 mm ² , 24 - 16 AWG |
| Torque setting with screw terminals | 0,5 Nm | 0,5 Nm | 0,5 Nm |
| Dimensions | | | |
| Height | 94 mm | 94 mm | 94 mm |
| Width | 45 mm | 45 mm | 45 mm |
| Depth | 121 mm | 121 mm | 121 mm |
| Weight | 360 g | 360 g | 350 g |

Where standards are undated, the 2014-07 latest editions shall apply.

Order no. 777504 – 787502

See below for more order numbers

| General | 777504 | 787500 | 787502 |
|--------------------------------------|--|--|--|
| Approvals | CCC, CE, EAC (Eurasian), TÜV, cULus Listed | CCC, CE, EAC (Eurasian), TÜV, cULus Listed | CCC, CE, EAC (Eurasian), TÜV, cULus Listed |
| Electrical data | 777504 | 787500 | 787502 |
| Supply voltage | | | |
| Voltage | 24 V | 24 V | 24 V |
| Kind | DC | DC | DC |
| Voltage tolerance | -15 %/+10 % | -15 %/+10 % | -15 %/+10 % |
| Output of external power supply (DC) | 4,5 W | 4,5 W | 4,5 W |
| Residual ripple DC | 160 % | 160 % | 160 % |
| Duty cycle | 100 % | 100 % | 100 % |
| Max. inrush current impulse | | | |
| Current pulse, A1 | 5 A | 5 A | 5 A |
| Pulse duration, A1 | 1 ms | 1 ms | 1 ms |

Safety relays PNOZ X PNOZ XV2P

| Inputs | 777504 | 787500 | 787502 |
|--|---------------|---------------|---------------|
| Number | 2 | 2 | 2 |
| Voltage at | | | |
| Input circuit DC | 24 V | 24 V | 24 V |
| Start circuit DC | 24 V | 24 V | 24 V |
| Feedback loop DC | 24 V | 24 V | 24 V |
| Current at | | | |
| Input circuit DC | 35 mA | 35 mA | 35 mA |
| Start circuit DC | 40 mA | 40 mA | 40 mA |
| Feedback loop DC | 3,5 mA | 3,5 mA | 3,5 mA |
| Min. input resistance at power-on | 143 Ohm | 143 Ohm | 143 Ohm |
| Max. overall cable resistance R _{lmax} | | | |
| Single-channel at UB DC | 100 Ohm | 100 Ohm | 100 Ohm |
| Dual-channel with detection of shorts across contacts at UB DC | 10 Ohm | 10 Ohm | 10 Ohm |
| Relay outputs | 777504 | 787500 | 787502 |
| Number of output contacts | | | |
| Safety contacts (N/O), instantaneous | 2 | 2 | 2 |
| Safety contacts (N/O), delayed | 2 | 2 | 2 |
| Max. short circuit current I _K | 1 kA | 1 kA | 1 kA |
| Utilisation category | | | |
| In accordance with the standard | EN 60947-4-1 | EN 60947-4-1 | EN 60947-4-1 |
| Utilisation category of safety contacts | | | |
| AC1 at | 240 V | 240 V | 240 V |
| Min. current | 0,01 A | 0,01 A | 0,01 A |
| Max. current | 8 A | 8 A | 8 A |
| Max. power | 2000 VA | 2000 VA | 2000 VA |
| DC1 at | 24 V | 24 V | 24 V |
| Min. current | 0,01 A | 0,01 A | 0,01 A |
| Max. current | 8 A | 8 A | 8 A |
| Max. power | 200 W | 200 W | 200 W |

Safety relays PNOZ X PNOZ XV2P

| Relay outputs | 777504 | 787500 | 787502 |
|---|----------------------|----------------------|----------------------|
| Utilisation category of safety contacts delayed | | | |
| AC1 at | 240 V | 240 V | 240 V |
| Min. current | 0,01 A | 0,01 A | 0,01 A |
| Max. current | 8 A | 8 A | 8 A |
| Max. power | 2000 VA | 2000 VA | 2000 VA |
| DC1 at | 24 V | 24 V | 24 V |
| Min. current | 0,01 A | 0,01 A | 0,01 A |
| Max. current | 8 A | 8 A | 8 A |
| Max. power | 200 W | 200 W | 200 W |
| Utilisation category | | | |
| In accordance with the standard | EN 60947-5-1 | EN 60947-5-1 | EN 60947-5-1 |
| Utilisation category of safety contacts | | | |
| AC15 at | 230 V | 230 V | 230 V |
| Max. current | 5 A | 5 A | 5 A |
| DC13 (6 cycles/min) at | 24 V | 24 V | 24 V |
| Max. current | 7 A | 7 A | 7 A |
| Utilisation category of safety contacts delayed | | | |
| AC15 at | 230 V | 230 V | 230 V |
| Max. current | 5 A | 5 A | 5 A |
| DC13 (6 cycles/min) at | 24 V | 24 V | 24 V |
| Max. current | 7 A | 7 A | 7 A |
| Utilisation category in accordance with UL | | | |
| Voltage | 240 V AC G. P. | 240 V AC G. P. | 240 V AC G. P. |
| With current | 8 A | 8 A | 8 A |
| Pilot Duty | C300, R300 | C300, R300 | C300, R300 |
| External contact fuse protection, safety contacts | | | |
| In accordance with the standard | EN 60947-5-1 | EN 60947-5-1 | EN 60947-5-1 |
| Max. melting integral | 240 A ² s | 240 A ² s | 240 A ² s |
| Blow-out fuse, quick | 10 A | 10 A | 10 A |
| Blow-out fuse, slow | 6 A | 6 A | 6 A |
| Blow-out fuse, gG | 10 A | 10 A | 10 A |
| Circuit breaker 24V AC/DC, characteristic B/C | 6 A | 6 A | 6 A |

Safety relays PNOZ X PNOZ XV2P

| Relay outputs | 777504 | 787500 | 787502 |
|--|--------------------------------------|--------------------------------------|--------------------------------------|
| External contact fuse protection, delayed safety contacts | | | |
| Max. melting integral | 240 A²s | 240 A²s | 240 A²s |
| Blow-out fuse, quick | 10 A | 10 A | 10 A |
| Blow-out fuse, slow | 6 A | 6 A | 6 A |
| Blow-out fuse, gG | 10 A | 10 A | 10 A |
| Circuit breaker 24 V AC/DC, characteristic B/C | 6 A | 6 A | 6 A |
| Contact material | AgSnO₂ + 0,2 µm Au | AgSnO₂ + 0,2 µm Au | AgSnO₂ + 0,2 µm Au |
| Conventional thermal current while loading several contacts | 777504 | 787500 | 787502 |
| I _{th} per contact at UB DC; AC1: 240 V, DC1: 24 V | | | |
| Conv. therm. current with 1 contact | 8 A | 8 A | 8 A |
| Conv. therm. current with 2 contacts | 7 A | 7 A | 7 A |
| Conv. therm. current with 3 contacts | 5,7 A | 5,7 A | 5,7 A |
| Conv. therm. current with 4 contacts | 5 A | 5 A | 5 A |
| Times | 777504 | 787500 | 787502 |
| Switch-on delay | | | |
| With automatic start typ. | 350 ms | 350 ms | 350 ms |
| With automatic start max. | 650 ms | 650 ms | 650 ms |
| With automatic start after power on typ. | 385 ms | 385 ms | 385 ms |
| With automatic start after power on max. | 700 ms | 700 ms | 700 ms |
| With monitored start typ. | 35 ms | 35 ms | 35 ms |
| With monitored start max. | 70 ms | 70 ms | 70 ms |
| Delay-on de-energisation | | | |
| With E-STOP typ. | 15 ms | 15 ms | 15 ms |
| With E-STOP max. | 30 ms | 30 ms | 30 ms |
| With power failure typ. | 85 ms | 85 ms | 85 ms |
| With power failure max. | 200 ms | 200 ms | 200 ms |

Safety relays PNOZ X PNOZ XV2P

| Times | 777504 | 787500 | 787502 |
|--|---|--|---|
| Recovery time at max. switching frequency 1/s | | | |
| After E-STOP | 50 ms +tv | 50 ms +tv | 50 ms +tv |
| After power failure | 250 ms | 250 ms | 250 ms |
| Delay time tv | 0,5 s | 0,1 s, 0,5 s, 1 s, 2 s, 4 s, 6 s, 8 s, 10 s, 15 s, 20 s, 25 s, 30 s | 0,1 s, 0,2 s, 0,3 s, 0,4 s, 0,5 s, 0,6 s, 0,7 s, 0,8 s, 1 s, 1,5 s, 2 s, 3 s |
| Time accuracy | -15 %/+15 % +50 ms | -15 %/+15 % +50 ms | -15 %/+15 % +50 ms |
| Repetition accuracy | 2 % | 2 % | 2 % |
| Waiting period with a monitored start | 300 ms | 300 ms | 300 ms |
| Min. start pulse duration with a monitored start | 30 ms | 30 ms | 30 ms |
| Supply interruption before de-energisation | 20 ms | 20 ms | 20 ms |
| Simultaneity, channel 1 and 2 max. | ∞ | ∞ | ∞ |
| Environmental data | 777504 | 787500 | 787502 |
| Climatic suitability | EN 60068-2-78 | EN 60068-2-78 | EN 60068-2-78 |
| Ambient temperature | | | |
| Temperature range | -10 - 55 °C | -10 - 55 °C | -10 - 55 °C |
| Storage temperature | | | |
| Temperature range | -40 - 85 °C | -40 - 85 °C | -40 - 85 °C |
| Climatic suitability | | | |
| Humidity | 93 % r. h. at 40 °C | 93 % r. h. at 40 °C | 93 % r. h. at 40 °C |
| Condensation during operation | Not permitted | Not permitted | Not permitted |
| EMC | EN 60947-5-1, EN 61000-6-2, EN 61326-3-1 | EN 60947-5-1, EN 61000-6-2, EN 61326-3-1 | EN 60947-5-1, EN 61000-6-2, EN 61326-3-1 |
| Vibration | | | |
| In accordance with the standard | EN 60068-2-6 | EN 60068-2-6 | EN 60068-2-6 |
| Frequency | 10 - 55 Hz | 10 - 55 Hz | 10 - 55 Hz |
| Amplitude | 0,35 mm | 0,35 mm | 0,35 mm |
| Airgap creepage | | | |
| In accordance with the standard | EN 60947-1 | EN 60947-1 | EN 60947-1 |
| Overvoltage category | III / II | III / II | III / II |
| Pollution degree | 2 | 2 | 2 |
| Rated insulation voltage | 250 V | 250 V | 250 V |
| Rated impulse withstand voltage | 4 kV | 4 kV | 4 kV |

Safety relays PNOZ X PNOZ XV2P

| Environmental data | 777504 | 787500 | 787502 |
|---|---|--|--|
| Protection type | | | |
| Mounting area (e.g. control cabinet) | IP54 | IP54 | IP54 |
| Housing | IP40 | IP40 | IP40 |
| Terminals | IP20 | IP20 | IP20 |
| Mechanical data | 777504 | 787500 | 787502 |
| Mounting position | Any | Any | Any |
| Mechanical life | 10,000,000 cycles | 10,000,000 cycles | 10,000,000 cycles |
| Material | | | |
| Bottom | PPO UL 94 V0 | PPO UL 94 V0 | PPO UL 94 V0 |
| Front | ABS UL 94 V0 | ABS UL 94 V0 | ABS UL 94 V0 |
| Top | PPO UL 94 V0 | PPO UL 94 V0 | PPO UL 94 V0 |
| Connection type | Screw terminal | Spring-loaded terminal | Spring-loaded terminal |
| Mounting type | plug-in | plug-in | plug-in |
| Conductor cross section with screw terminals | | | |
| 1 core flexible | 0,25 - 2,5 mm², 24 - 12 AWG | – | – |
| 2 core with the same cross section, flexible with crimp connectors, no plastic sleeve | 0,25 - 1 mm², 24 - 16 AWG | – | – |
| 2 core with the same cross section, flexible without crimp connectors or with TWIN crimp connectors | 0,2 - 1,5 mm², 24 - 16 AWG | – | – |
| Torque setting with screw terminals | | | |
| | 0,5 Nm | – | – |
| Conductor cross section with spring-loaded terminals: Flexible with/without crimp connector | | | |
| | – | 0,2 - 1,5 mm², 24 - 16 AWG | 0,2 - 1,5 mm², 24 - 16 AWG |
| Spring-loaded terminals: Terminal points per connection | | | |
| | – | 2 | 2 |
| Stripping length with spring-loaded terminals | | | |
| | – | 8 mm | 8 mm |
| Dimensions | | | |
| Height | 94 mm | 101 mm | 101 mm |
| Width | 45 mm | 45 mm | 45 mm |
| Depth | 121 mm | 121 mm | 121 mm |
| Weight | 350 g | 355 g | 355 g |

Where standards are undated, the 2014-07 latest editions shall apply.

Safety relays PNOZ X PNOZ XV2P

Order no. 787503 – 787504

| General | 787503 | 787504 |
|--|--|--|
| Approvals | CCC, CE, EAC (Eurasian), TÜV, cULus Listed | CCC, CE, EAC (Eurasian), TÜV, cULus Listed |
| Electrical data | 787503 | 787504 |
| Supply voltage | | |
| Voltage | 24 V | 24 V |
| Kind | DC | DC |
| Voltage tolerance | -15 %/+10 % | -15 %/+10 % |
| Output of external power supply (DC) | 4,5 W | 4,5 W |
| Residual ripple DC | 160 % | 160 % |
| Duty cycle | 100 % | 100 % |
| Max. inrush current impulse | | |
| Current pulse, A1 | 5 A | 5 A |
| Pulse duration, A1 | 1 ms | 1 ms |
| Inputs | 787503 | 787504 |
| Number | 2 | 2 |
| Voltage at | | |
| Input circuit DC | 24 V | 24 V |
| Start circuit DC | 24 V | 24 V |
| Feedback loop DC | 24 V | 24 V |
| Current at | | |
| Input circuit DC | 35 mA | 35 mA |
| Start circuit DC | 40 mA | 40 mA |
| Feedback loop DC | 3,5 mA | 3,5 mA |
| Min. input resistance at power-on | 143 Ohm | 143 Ohm |
| Max. overall cable resistance RI-max | | |
| Single-channel at UB DC | 100 Ohm | 100 Ohm |
| Dual-channel with detection of shorts across contacts at UB DC | 10 Ohm | 10 Ohm |
| Relay outputs | 787503 | 787504 |
| Number of output contacts | | |
| Safety contacts (N/O), instantaneous | 2 | 2 |
| Safety contacts (N/O), delayed | 2 | 2 |
| Max. short circuit current I _K | 1 kA | 1 kA |
| Utilisation category | | |
| In accordance with the standard | EN 60947-4-1 | EN 60947-4-1 |

Safety relays PNOZ X PNOZ XV2P

| Relay outputs | 787503 | 787504 |
|---|----------------|----------------|
| Utilisation category of safety contacts | | |
| AC1 at | 240 V | 240 V |
| Min. current | 0,01 A | 0,01 A |
| Max. current | 8 A | 8 A |
| Max. power | 2000 VA | 2000 VA |
| DC1 at | 24 V | 24 V |
| Min. current | 0,01 A | 0,01 A |
| Max. current | 8 A | 8 A |
| Max. power | 200 W | 200 W |
| Utilisation category of safety contacts delayed | | |
| AC1 at | 240 V | 240 V |
| Min. current | 0,01 A | 0,01 A |
| Max. current | 8 A | 8 A |
| Max. power | 2000 VA | 2000 VA |
| DC1 at | 24 V | 24 V |
| Min. current | 0,01 A | 0,01 A |
| Max. current | 8 A | 8 A |
| Max. power | 200 W | 200 W |
| Utilisation category | | |
| In accordance with the standard | EN 60947-5-1 | EN 60947-5-1 |
| Utilisation category of safety contacts | | |
| AC15 at | 230 V | 230 V |
| Max. current | 5 A | 5 A |
| DC13 (6 cycles/min) at | 24 V | 24 V |
| Max. current | 7 A | 7 A |
| Utilisation category of safety contacts delayed | | |
| AC15 at | 230 V | 230 V |
| Max. current | 5 A | 5 A |
| DC13 (6 cycles/min) at | 24 V | 24 V |
| Max. current | 7 A | 7 A |
| Utilisation category in accordance with UL | | |
| Voltage | 240 V AC G. P. | 240 V AC G. P. |
| With current | 8 A | 8 A |
| Pilot Duty | C300, R300 | C300, R300 |

Safety relays PNOZ X PNOZ XV2P

| Relay outputs | 787503 | 787504 |
|--|--------------------------------------|--------------------------------------|
| External contact fuse protection, safety contacts | | |
| In accordance with the standard | EN 60947-5-1 | EN 60947-5-1 |
| Max. melting integral | 240 A²s | 240 A²s |
| Blow-out fuse, quick | 10 A | 10 A |
| Blow-out fuse, slow | 6 A | 6 A |
| Blow-out fuse, gG | 10 A | 10 A |
| Circuit breaker 24V AC/DC, characteristic B/C | 6 A | 6 A |
| External contact fuse protection, delayed safety contacts | | |
| Max. melting integral | 240 A²s | 240 A²s |
| Blow-out fuse, quick | 10 A | 10 A |
| Blow-out fuse, slow | 6 A | 6 A |
| Blow-out fuse, gG | 10 A | 10 A |
| Circuit breaker 24 V AC/DC, characteristic B/C | 6 A | 6 A |
| Contact material | AgSnO₂ + 0,2 µm Au | AgSnO₂ + 0,2 µm Au |
| Conventional thermal current while loading several contacts | 787503 | 787504 |
| I _{th} per contact at UB DC; AC1: 240 V, DC1: 24 V | | |
| Conv. therm. current with 1 contact | 8 A | 8 A |
| Conv. therm. current with 2 contacts | 7 A | 7 A |
| Conv. therm. current with 3 contacts | 5,7 A | 5,7 A |
| Conv. therm. current with 4 contacts | 5 A | 5 A |
| Times | 787503 | 787504 |
| Switch-on delay | | |
| With automatic start typ. | 350 ms | 350 ms |
| With automatic start max. | 650 ms | 650 ms |
| With automatic start after power on typ. | 385 ms | 385 ms |
| With automatic start after power on max. | 700 ms | 700 ms |
| With monitored start typ. | 35 ms | 35 ms |
| With monitored start max. | 70 ms | 70 ms |

Safety relays PNOZ X PNOZ XV2P

| Times | 787503 | 787504 |
|--|--|--|
| Delay-on de-energisation | | |
| With E-STOP typ. | 15 ms | 15 ms |
| With E-STOP max. | 30 ms | 30 ms |
| With power failure typ. | 85 ms | 85 ms |
| With power failure max. | 200 ms | 200 ms |
| Recovery time at max. switching frequency 1/s | | |
| After E-STOP | 50 ms +tv | 50 ms +tv |
| After power failure | 250 ms | 250 ms |
| Delay time tv | 1 s | 0,5 s |
| Time accuracy | -15 %/+15 % +50 ms | -15 %/+15 % +50 ms |
| Repetition accuracy | 2 % | 2 % |
| Waiting period with a monitored start | 300 ms | 300 ms |
| Min. start pulse duration with a monitored start | 30 ms | 30 ms |
| Supply interruption before de-energisation | 20 ms | 20 ms |
| Simultaneity, channel 1 and 2 max. | ∞ | ∞ |
| Environmental data | 787503 | 787504 |
| Climatic suitability | EN 60068-2-78 | EN 60068-2-78 |
| Ambient temperature | | |
| Temperature range | -10 - 55 °C | -10 - 55 °C |
| Storage temperature | | |
| Temperature range | -40 - 85 °C | -40 - 85 °C |
| Climatic suitability | | |
| Humidity | 93 % r. h. at 40 °C | 93 % r. h. at 40 °C |
| Condensation during operation | Not permitted | Not permitted |
| EMC | EN 60947-5-1, EN 61000-6-2, EN 61326-3-1 | EN 60947-5-1, EN 61000-6-2, EN 61326-3-1 |
| Vibration | | |
| In accordance with the standard | EN 60068-2-6 | EN 60068-2-6 |
| Frequency | 10 - 55 Hz | 10 - 55 Hz |
| Amplitude | 0,35 mm | 0,35 mm |
| Airgap creepage | | |
| In accordance with the standard | EN 60947-1 | EN 60947-1 |
| Overvoltage category | III / II | III / II |
| Pollution degree | 2 | 2 |
| Rated insulation voltage | 250 V | 250 V |
| Rated impulse withstand voltage | 4 kV | 4 kV |

Safety relays PNOZ X PNOZ XV2P

| Environmental data | 787503 | 787504 |
|---|--|--|
| Protection type | | |
| Mounting area (e.g. control cabinet) | IP54 | IP54 |
| Housing | IP40 | IP40 |
| Terminals | IP20 | IP20 |
| Mechanical data | 787503 | 787504 |
| Mounting position | Any | Any |
| Mechanical life | 10,000,000 cycles | 10,000,000 cycles |
| Material | | |
| Bottom | PPO UL 94 V0 | PPO UL 94 V0 |
| Front | ABS UL 94 V0 | ABS UL 94 V0 |
| Top | PPO UL 94 V0 | PPO UL 94 V0 |
| Connection type | Spring-loaded terminal | Spring-loaded terminal |
| Mounting type | plug-in | plug-in |
| Conductor cross section with spring-loaded terminals: Flexible with/without crimp connector | 0,2 - 1,5 mm², 24 - 16 AWG | 0,2 - 1,5 mm², 24 - 16 AWG |
| Spring-loaded terminals: Terminal points per connection | 2 | 2 |
| Stripping length with spring-loaded terminals | 8 mm | 8 mm |
| Dimensions | | |
| Height | 101 mm | 101 mm |
| Width | 45 mm | 45 mm |
| Depth | 121 mm | 121 mm |
| Weight | 345 g | 345 g |

Where standards are undated, the 2014-07 latest editions shall apply.

Safety relays PNOZ X PNOZ XV2P

Safety characteristic data

| Operating mode | EN ISO 13849-1: 2015 PL | EN ISO 13849-1: 2015 Category | EN 62061 SIL CL | EN 62061 PFH _D [1/h] | EN ISO 13849-1: 2015 T _M [year] |
|--------------------------------|----------------------------|----------------------------------|--------------------|------------------------------------|---|
| Safety contacts, instantaneous | PL e | Cat. 4 | SIL CL 3 | 2,31E-09 | 20 |
| Safety contacts, delayed <30 s | PL d | Cat. 3 | SIL CL 3 | 2,64E-09 | 20 |
| Safety contacts, delayed ≥30 s | PL c | Cat. 1 | SIL CL 1 | 2,87E-09 | 20 |

All the units used within a safety function must be considered when calculating the safety characteristic data.

Supplementary data

The PFH value depends on the switching frequency and the load on the relay output. If the service life graphs are not accessible, the stated PFH value can be used irrespective of the switching frequency and the load, as the PFH value already considers the relay's B10d value as well as the failure rates of the other components.

Safety relays PNOZ X PNOZ XV2P

Service life graph

The service life graphs indicate the number of cycles from which failures due to wear must be expected. The wear is mainly caused by the electrical load; the mechanical load is negligible.

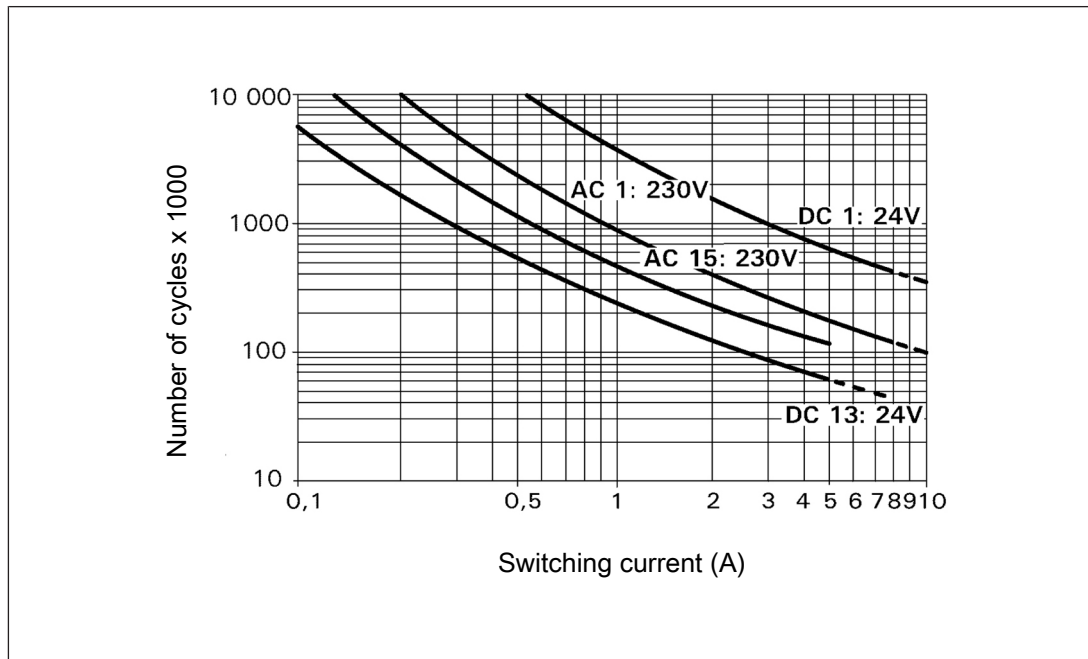

Example

- ▶ Inductive load: 0.2 A
- ▶ Utilisation category: AC15
- ▶ Contact service life: 4 000 000 cycles

Provided the application to be implemented requires fewer than 4 000 000 cycles, the PFH value (see Technical details) can be used in the calculation.

To increase the service life, sufficient spark suppression must be provided on all output contacts. With capacitive loads, any power surges that occur must be noted. With DC contactors, use flywheel diodes for spark suppression.

Safety relays PNOZ X PNOZ XV2P

Order reference

| Product type | Features | Connection type | Order no. |
|--------------|---|-------------------------|-----------|
| PNOZ XV2P | 24 VDC; Delay: up to 30 s selectable | Screw terminals | 777 500 |
| PNOZ XV2P C | 24 VDC; Delay: up to 30 s selectable | Spring-loaded terminals | 787 500 |
| PNOZ XV2P | 24 VDC; Delay: up to 3 s selectable | Screw terminals | 777 502 |
| PNOZ XV2P C | 24 VDC; Delay: up to 3 s selectable | Spring-loaded terminals | 787 502 |
| PNOZ XV2P | 24 VDC; Delay: 1 s fixed | Screw terminals | 777 503 |
| PNOZ XV2P C | 24 VDC; Delay: 1 s fixed | Spring-loaded terminals | 787 503 |
| PNOZ XV2P | 24 VDC; Delay: 0.5 s fixed | Screw terminals | 777 504 |
| PNOZ XV2P C | 24 VDC; Delay: 0.5 s fixed | Spring-loaded terminals | 787 504 |

Safety relays PNOZ X PNOZ XV2.1P

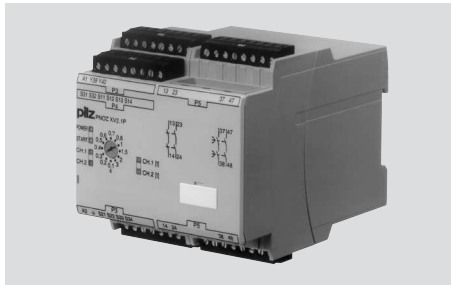

Unit features

- ▶ Positive-guided relay outputs:
 - 2 safety contacts (N/O), instantaneous
 - 2 safety contacts (N/O), delay-on de-energisation
- ▶ Connection options for:
 - E-STOP pushbutton
 - Safety gate limit switch
 - Start button
- ▶ LED display for:
 - Supply voltage
 - Switch state of the safety contacts
 - Start circuit
- ▶ Delay time fixed or selectable
- ▶ Possible to cancel delay time
- ▶ Plug-in connection terminals (either spring-loaded terminal or screw terminal)
- ▶ See order reference for unit types

Safety relays PNOZ X PNOZ XV2.1P

Block diagram/terminal configuration

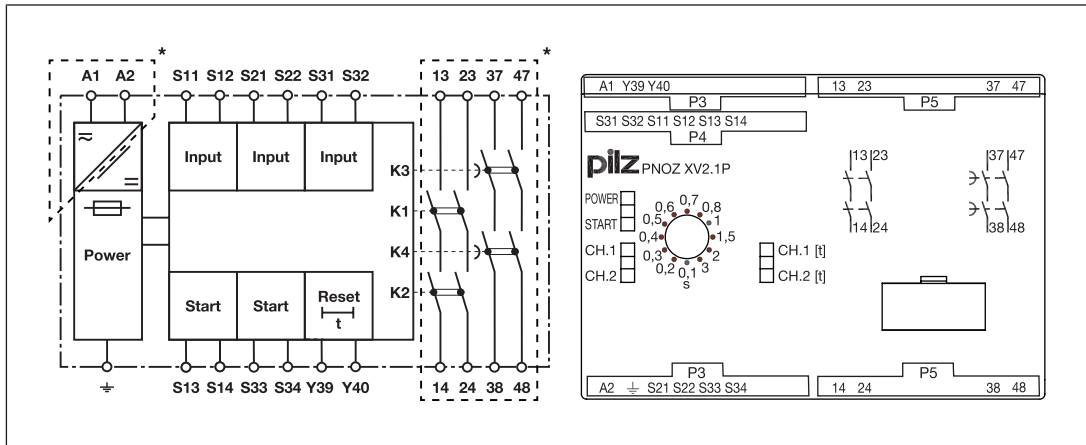

*Insulation between the non-marked area and the relay contacts: Basic insulation (over-voltage category III), Protective separation (overvoltage category II)

Function Description

The safety relay PNOZ XV2.1P provides a safety-oriented interruption of a safety circuit. When supply voltage is supplied the "POWER" LED is lit. The unit is ready for operation when the reset circuit Y39-Y40 and the start circuit S13-S14 are closed.

- ▶ Input circuit is closed (e.g. E-STOP pushbutton not operated):
 - The "START" LED is lit.
 - The LEDs "CH.1", "CH.1 [t]" and "CH.2", "CH.2 [t]" are lit.
 - The safety contacts 13-14, 23-24, 37-38 and 47-48 are closed. The unit is active.
 - The "START" LED goes out.
- ▶ Input circuit is opened (e.g. E-STOP pushbutton operated):
 - The LEDs "CH.1" and "CH.2" go out.
 - Safety contacts 13-14 and 23-24 are redundantly opened.
 - Safety contacts 37-38 and 47-48 open after the delay time has elapsed.
 - The LEDs "CH.1 [t]" and "CH.2 [t]" go out.

Before the unit can be restarted, the delay time must have elapsed and the unit must again be ready for operation.

Safety relays PNOZ X PNOZ XV2.1P

Set delay time:

On units with selectable delay time, the delay time of the safety contacts 37-38 and 47-48 can be set on the front of the unit using a screwdriver.

Reset function:

The delay time cycle can be ended prematurely by opening the reset circuit Y39-Y40. For this purpose, one N/C contact is connected between Y39-Y40 instead of a link.

Operating modes

- ▶ Single-channel operation: No redundancy in the input circuit, earth faults in the start and input circuit are detected.
- ▶ Dual-channel operation with detection of shorts across contacts: Redundant input circuit, detects PNOZ XV2.1P
 - earth faults in the start and input circuit,
 - short circuits in the input circuit,
 - Shorts across contacts in the input circuit.
- ▶ Automatic start: Unit is active once the input circuit has been closed.
- ▶ Monitored start: Unit is active once the input circuit is closed and once the start circuit is closed after the waiting period has elapsed (see [Technical details \[📖 325\]](#)).
- ▶ Increase in the number of available contacts by connecting contact expander modules or external contactors/relays.

Safety relays PNOZ X PNOZ XV2.1P

Timing diagram

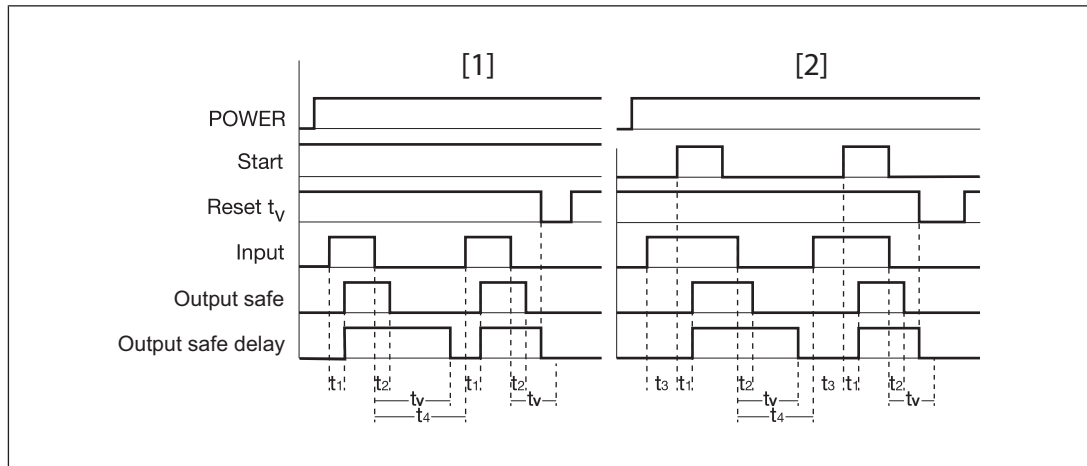

Legend

- ▶ Power: Supply voltage
- ▶ Start: Start circuit
- ▶ Reset t_v : Reset circuit
- ▶ Input: Input circuit
- ▶ Output safe: Safety contacts, instantaneous
- ▶ Output safe delay: Safety contacts, delayed
- ▶ [1]: Automatic start
- ▶ [2]: Monitored start
- ▶ t_1 : Switch-on delay
- ▶ t_2 : Delay-on de-energisation
- ▶ t_3 : Waiting period with a monitored start
- ▶ t_4 : Recovery time
- ▶ t_v : Delay time

Installation

- ▶ The unit should be installed in a control cabinet with a protection type of at least IP54.
- ▶ Use the notch on the rear of the unit to attach it to a DIN rail.
- ▶ Ensure the unit is mounted securely on a vertical DIN rail (35 mm) by using a fixing element (e.g. retaining bracket or an end angle).

Safety relays PNOZ X PNOZ XV2.1P

Wiring

Please note:

- ▶ Information given in the "[Technical details \[325\]](#)" must be followed.
- ▶ Delivery status of units with screw terminals: Link between S11-S12 (dual-channel input circuit) and link between Y39-Y40 (reset circuit)
- ▶ Outputs 13-14, 23-24 are instantaneous safety contacts, outputs 37-38, 47-48 are delay-on de-energisation safety contacts.
- ▶ Do not connect undesignated terminals.
- ▶ To prevent contact welding, a fuse should be connected before the output contacts (see [Technical details \[325\]](#)).
- ▶ Calculation of the max. cable length l_{\max} in the input circuit:

$$l_{\max} = \frac{R_{l_{\max}}}{R_1 / \text{km}}$$

$R_{l_{\max}}$ = max. overall cable resistance (see [Technical details \[325\]](#))

R_1 / km = cable resistance/km

- ▶ Use copper wire that can withstand 60/75 °C.
- ▶ Sufficient fuse protection must be provided on all output contacts with capacitive and inductive loads.
- ▶ Do not switch low currents using contacts that have been used previously with high currents.
- ▶ Connect operational earth terminal to functional earth.
- ▶ Ensure the wiring and EMC requirements of IEC 60204-1 are met.

Important for detection of shorts across contacts:

As this function for detecting shorts across contacts is not failsafe, it is tested by Pilz during the final control check. If there is a danger of exceeding the cable length, we recommend the following test once the unit is installed:

1. Unit ready for operation (output contacts closed)
2. Short circuit the test terminals S22, S32 for detecting shorts across the inputs.
3. The unit's fuse must be triggered and the output contacts must open. Cable lengths in the scale of the maximum length can delay the fuse triggering for up to 2 minutes.
4. Reset the fuse: Remove the short circuit and switch off the supply voltage for approx. 1 minute.

Safety relays PNOZ X PNOZ XV2.1P

Preparing for operation

| Supply voltage | AC | DC |
|---|----------------|--------------|
| | | |
| Input circuit | Single-channel | Dual-channel |
| E-STOP without detection of shorts across contacts | | |
| E-STOP with detection of shorts across contacts | | |
| Safety gate without detection of shorts across contacts | | |
| Safety gate with detection of shorts across contacts | | |

Safety relays PNOZ X PNOZ XV2.1P

| | E-STOP wiring | |
|-----------------------------------|--|---------------------------------------|
| Start circuit | Safety gate without start-up test | Safety gate with start-up test |
| Automatic start | | |
| Monitored start | | |
| Reset delay time | Without reset | With reset |
| Link or N/C contact | | |
| Feedback loop | Automatic start | Monitored start |
| Contacts from external contactors | | |

Legend

- ▶ S1/S2: E-STOP/safety gate switch
- ▶ S3: Reset button
- ▶ ↑↑: Switch operated
- ▶ : Gate open
- ▶ : Gate closed

Safety relays PNOZ X PNOZ XV2.1P

Dimensions in mm

* with spring-loaded terminals

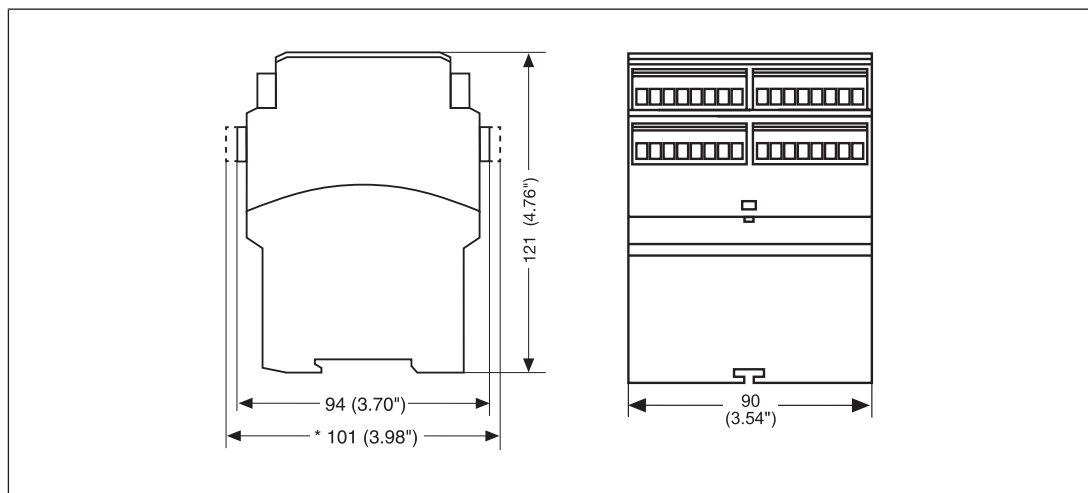

Technical details

Order no. 777540 – 777544

See below for more order numbers

| General | 777540 | 777542 | 777544 |
|--------------------------------------|--|--|--|
| Approvals | CCC, CE, EAC (Eurasian), TÜV, cULus Listed | CCC, CE, EAC (Eurasian), TÜV, cULus Listed | CCC, CE, EAC (Eurasian), TÜV, cULus Listed |
| Electrical data | 777540 | 777542 | 777544 |
| Supply voltage | | | |
| Voltage | 24 - 240 V | 24 - 240 V | 24 - 240 V |
| Kind | AC/DC | AC/DC | AC/DC |
| Voltage tolerance | -15 %/+10 % | -15 %/+10 % | -15 %/+10 % |
| Output of external power supply (AC) | 8,5 VA | 8,5 VA | 8,5 VA |
| Output of external power supply (DC) | 5 W | 5 W | 5 W |
| Frequency range AC | 50 - 60 Hz | 50 - 60 Hz | 50 - 60 Hz |
| Residual ripple DC | 160 % | 160 % | 160 % |
| Duty cycle | 100 % | 100 % | 100 % |
| Inputs | 777540 | 777542 | 777544 |
| Number | 2 | 2 | 2 |
| Voltage at | | | |
| Input circuit DC | 24 V | 24 V | 24 V |
| Start circuit DC | 24 V | 24 V | 24 V |
| Feedback loop DC | 24 V | 24 V | 24 V |

Safety relays PNOZ X PNOZ XV2.1P

| Inputs | 777540 | 777542 | 777544 |
|--|---------------------|---------------------|---------------------|
| Current at | | | |
| Input circuit DC | 35 mA | 35 mA | 35 mA |
| Start circuit DC | 30 mA | 30 mA | 30 mA |
| Feedback loop DC | 3 mA | 3 mA | 3 mA |
| Max. overall cable resistance R _{lmax} | | | |
| Single-channel at UB DC | 200 Ohm | 200 Ohm | 200 Ohm |
| Single-channel at UB AC | 200 Ohm | 200 Ohm | 200 Ohm |
| Dual-channel with detection of shorts across contacts at UB DC | 20 Ohm | 20 Ohm | 20 Ohm |
| Dual-channel with detection of shorts across contacts at UB AC | 20 Ohm | 20 Ohm | 20 Ohm |
| Relay outputs | 777540 | 777542 | 777544 |
| Number of output contacts | | | |
| Safety contacts (N/O), instantaneous | 2 | 2 | 2 |
| Safety contacts (N/O), delayed | 2 | 2 | 2 |
| Max. short circuit current I _K | 1 kA | 1 kA | 1 kA |
| Utilisation category | | | |
| In accordance with the standard | EN 60947-4-1 | EN 60947-4-1 | EN 60947-4-1 |
| Utilisation category of safety contacts | | | |
| AC1 at | 240 V | 240 V | 240 V |
| Min. current | 0,01 A | 0,01 A | 0,01 A |
| Max. current | 8 A | 8 A | 8 A |
| Max. power | 2000 VA | 2000 VA | 2000 VA |
| DC1 at | 24 V | 24 V | 24 V |
| Min. current | 0,01 A | 0,01 A | 0,01 A |
| Max. current | 8 A | 8 A | 8 A |
| Max. power | 200 W | 200 W | 200 W |

Safety relays PNOZ X PNOZ XV2.1P

| Relay outputs | 777540 | 777542 | 777544 |
|---|----------------------|----------------------|----------------------|
| Utilisation category of safety contacts delayed | | | |
| AC1 at | 240 V | 240 V | 240 V |
| Min. current | 0,01 A | 0,01 A | 0,01 A |
| Max. current | 8 A | 8 A | 8 A |
| Max. power | 2000 VA | 2000 VA | 2000 VA |
| DC1 at | 24 V | 24 V | 24 V |
| Min. current | 0,01 A | 0,01 A | 0,01 A |
| Max. current | 8 A | 8 A | 8 A |
| Max. power | 200 W | 200 W | 200 W |
| Utilisation category | | | |
| In accordance with the standard | EN 60947-5-1 | EN 60947-5-1 | EN 60947-5-1 |
| Utilisation category of safety contacts | | | |
| AC15 at | 230 V | 230 V | 230 V |
| Max. current | 5 A | 5 A | 5 A |
| DC13 (6 cycles/min) at | 24 V | 24 V | 24 V |
| Max. current | 7 A | 7 A | 7 A |
| Utilisation category of safety contacts delayed | | | |
| AC15 at | 230 V | 230 V | 230 V |
| Max. current | 5 A | 5 A | 5 A |
| DC13 (6 cycles/min) at | 24 V | 24 V | 24 V |
| Max. current | 7 A | 7 A | 7 A |
| Utilisation category in accordance with UL | | | |
| Voltage | 240 V AC G. P. | 240 V AC G. P. | 240 V AC G. P. |
| With current | 8 A | 8 A | 8 A |
| Pilot Duty | C300, R300 | C300, R300 | C300, R300 |
| External contact fuse protection, safety contacts | | | |
| In accordance with the standard | EN 60947-5-1 | EN 60947-5-1 | EN 60947-5-1 |
| Max. melting integral | 240 A ² s | 240 A ² s | 240 A ² s |
| Blow-out fuse, quick | 10 A | 10 A | 10 A |
| Blow-out fuse, slow | 6 A | 6 A | 6 A |
| Blow-out fuse, gG | 10 A | 10 A | 10 A |
| Circuit breaker 24V AC/DC, characteristic B/C | 6 A | 6 A | 6 A |

Safety relays PNOZ X PNOZ XV2.1P

| Relay outputs | 777540 | 777542 | 777544 |
|--|--------------------------------------|--------------------------------------|--------------------------------------|
| External contact fuse protection, delayed safety contacts | | | |
| Max. melting integral | 240 A²s | 240 A²s | 240 A²s |
| Blow-out fuse, quick | 10 A | 10 A | 10 A |
| Blow-out fuse, slow | 6 A | 6 A | 6 A |
| Blow-out fuse, gG | 10 A | 10 A | 10 A |
| Circuit breaker 24 V AC/DC, characteristic B/C | 6 A | 6 A | 6 A |
| Contact material | AgSnO₂ + 0,2 µm Au | AgSnO₂ + 0,2 µm Au | AgSnO₂ + 0,2 µm Au |
| Conventional thermal current while loading several contacts | 777540 | 777542 | 777544 |
| I _{th} per contact at UB AC; AC1: 240 V, DC1: 24 V | | | |
| Conv. therm. current with 1 contact | 8 A | 8 A | 8 A |
| Conv. therm. current with 2 contacts | 7 A | 7 A | 7 A |
| Conv. therm. current with 3 contacts | 5,7 A | 5,7 A | 5,7 A |
| Conv. therm. current with 4 contacts | 5 A | 5 A | 5 A |
| I _{th} per contact at UB DC; AC1: 240 V, DC1: 24 V | | | |
| Conv. therm. current with 1 contact | 8 A | 8 A | 8 A |
| Conv. therm. current with 2 contacts | 7 A | 7 A | 7 A |
| Conv. therm. current with 3 contacts | 5,7 A | 5,7 A | 5,7 A |
| Conv. therm. current with 4 contacts | 5 A | 5 A | 5 A |

Safety relays PNOZ X PNOZ XV2.1P

| Times | 777540 | 777542 | 777544 |
|--|---|--|--------------------|
| Switch-on delay | | | |
| With automatic start typ. | 400 ms | 400 ms | 400 ms |
| With automatic start max. | 550 ms | 550 ms | 550 ms |
| With automatic start after power on typ. | 820 ms | 820 ms | 820 ms |
| With automatic start after power on max. | 1.100 ms | 1.100 ms | 1.100 ms |
| With monitored start typ. | 35 ms | 35 ms | 35 ms |
| With monitored start max. | 60 ms | 60 ms | 60 ms |
| Delay-on de-energisation | | | |
| With E-STOP typ. | 15 ms | 15 ms | 15 ms |
| With E-STOP max. | 30 ms | 30 ms | 30 ms |
| With power failure typ. UB 240 V | 1 s | 1 s | 1 s |
| With power failure max. UB 240 V | 1450 ms | 1450 ms | 1450 ms |
| With power failure typ. UB 24 V | 130 ms | 130 ms | 130 ms |
| With power failure max. UB 24 V | 170 ms | 170 ms | 170 ms |
| Recovery time at max. switching frequency 1/s | | | |
| After E-STOP | 50 ms +tv | 50 ms +tv | 50 ms +tv |
| After power failure on wide-range power supply | 1500 ms | 1500 ms | 1500 ms |
| Delay time tv | 0,1 s, 0,5 s, 1 s, 2 s, 4 s, 6 s, 8 s, 10 s, 15 s, 20 s, 25 s, 30 s | 0,1 s, 0,2 s, 0,3 s, 0,4 s, 0,5 s, 0,6 s, 0,7 s, 0,8 s, 1 s, 1,5 s, 2 s, 3 s | 0,5 s |
| Time accuracy | -15 %/+15 % +50 ms | -15 %/+15 % +50 ms | -15 %/+15 % +50 ms |
| Repetition accuracy | 2 % | 2 % | 2 % |
| Waiting period with a monitored start | 300 ms | 300 ms | 300 ms |
| Min. start pulse duration with a monitored start | 30 ms | 30 ms | 30 ms |
| Supply interruption before de-energisation | 20 ms | 20 ms | 20 ms |
| Simultaneity, channel 1 and 2 max. | ∞ | ∞ | ∞ |
| Environmental data | 777540 | 777542 | 777544 |
| Climatic suitability | EN 60068-2-78 | EN 60068-2-78 | EN 60068-2-78 |

Safety relays PNOZ X PNOZ XV2.1P

| Environmental data | 777540 | 777542 | 777544 |
|--------------------------------------|---|---|---|
| Ambient temperature | | | |
| Temperature range | -10 - 55 °C | -10 - 55 °C | -10 - 55 °C |
| Storage temperature | | | |
| Temperature range | -40 - 85 °C | -40 - 85 °C | -40 - 85 °C |
| Climatic suitability | | | |
| Humidity | 93 % r. h. at 40 °C | 93 % r. h. at 40 °C | 93 % r. h. at 40 °C |
| Condensation during operation | Not permitted | Not permitted | Not permitted |
| EMC | EN 60947-5-1, EN 61000-6-2, EN 61000-6-4, EN 61326-3-1 | EN 60947-5-1, EN 61000-6-2, EN 61000-6-4, EN 61326-3-1 | EN 60947-5-1, EN 61000-6-2, EN 61000-6-4, EN 61326-3-1 |
| Vibration | | | |
| In accordance with the standard | EN 60068-2-6 | EN 60068-2-6 | EN 60068-2-6 |
| Frequency | 10 - 55 Hz | 10 - 55 Hz | 10 - 55 Hz |
| Amplitude | 0,35 mm | 0,35 mm | 0,35 mm |
| Airgap creepage | | | |
| In accordance with the standard | EN 60947-1 | EN 60947-1 | EN 60947-1 |
| Overvoltage category | III / II | III / II | III / II |
| Pollution degree | 2 | 2 | 2 |
| Rated insulation voltage | 250 V | 250 V | 250 V |
| Rated impulse withstand voltage | 4 kV | 4 kV | 4 kV |
| Protection type | | | |
| Mounting area (e.g. control cabinet) | IP54 | IP54 | IP54 |
| Housing | IP40 | IP40 | IP40 |
| Terminals | IP20 | IP20 | IP20 |
| Mechanical data | 777540 | 777542 | 777544 |
| Mounting position | Any | Any | Any |
| Mechanical life | 10,000,000 cycles | 10,000,000 cycles | 10,000,000 cycles |
| Material | | | |
| Bottom | PPO UL 94 V0 | PPO UL 94 V0 | PPO UL 94 V0 |
| Front | ABS UL 94 V0 | ABS UL 94 V0 | ABS UL 94 V0 |
| Top | PPO UL 94 V0 | PPO UL 94 V0 | PPO UL 94 V0 |
| Connection type | Screw terminal | Screw terminal | Screw terminal |
| Mounting type | plug-in | plug-in | plug-in |

Safety relays PNOZ X PNOZ XV2.1P

| Mechanical data | 777540 | 777542 | 777544 |
|---|--|--|--|
| Conductor cross section with screw terminals | | | |
| 1 core flexible | 0,25 - 2,5 mm ² , 24 - 12 AWG | 0,25 - 2,5 mm ² , 24 - 12 AWG | 0,25 - 2,5 mm ² , 24 - 12 AWG |
| 2 core with the same cross section, flexible with crimp connectors, no plastic sleeve | 0,25 - 1 mm ² , 24 - 16 AWG | 0,25 - 1 mm ² , 24 - 16 AWG | 0,25 - 1 mm ² , 24 - 16 AWG |
| 2 core with the same cross section, flexible without crimp connectors or with TWIN crimp connectors | 0,2 - 1,5 mm ² , 24 - 16 AWG | 0,2 - 1,5 mm ² , 24 - 16 AWG | 0,2 - 1,5 mm ² , 24 - 16 AWG |
| Torque setting with screw terminals | | | |
| | 0,5 Nm | 0,5 Nm | 0,5 Nm |
| Dimensions | | | |
| Height | 94 mm | 94 mm | 94 mm |
| Width | 90 mm | 90 mm | 90 mm |
| Depth | 121 mm | 121 mm | 121 mm |
| Weight | 520 g | 520 g | 510 g |

Where standards are undated, the 2014-07 latest editions shall apply.

Order no. 777548 – 787540

See below for more order numbers

| General | 777548 | 787540 |
|--------------------------------------|--|--|
| Approvals | CCC, CE, EAC (Eurasian), TÜV, cULus Listed | CCC, CE, EAC (Eurasian), TÜV, cULus Listed |
| Electrical data | 777548 | 787540 |
| Supply voltage | | |
| Voltage | 24 - 240 V | 24 - 240 V |
| Kind | AC/DC | AC/DC |
| Voltage tolerance | -15 %/+10 % | -15 %/+10 % |
| Output of external power supply (AC) | 8,5 VA | 8,5 VA |
| Output of external power supply (DC) | 5 W | 5 W |
| Frequency range AC | 50 - 60 Hz | 50 - 60 Hz |
| Residual ripple DC | 160 % | 160 % |
| Duty cycle | 100 % | 100 % |
| Inputs | 777548 | 787540 |
| Number | 2 | 2 |

Safety relays PNOZ X PNOZ XV2.1P

| Inputs | 777548 | 787540 |
|--|---------------------|---------------------|
| Voltage at | | |
| Input circuit DC | 24 V | 24 V |
| Start circuit DC | 24 V | 24 V |
| Feedback loop DC | 24 V | 24 V |
| Current at | | |
| Input circuit DC | 35 mA | 35 mA |
| Start circuit DC | 30 mA | 30 mA |
| Feedback loop DC | 3 mA | 3 mA |
| Max. overall cable resistance R _{I-max} | | |
| Single-channel at UB DC | 200 Ohm | 200 Ohm |
| Single-channel at UB AC | 200 Ohm | 200 Ohm |
| Dual-channel with detection of shorts across contacts at UB DC | 20 Ohm | 20 Ohm |
| Dual-channel with detection of shorts across contacts at UB AC | 20 Ohm | 20 Ohm |
| Relay outputs | 777548 | 787540 |
| Number of output contacts | | |
| Safety contacts (N/O), instantaneous | 2 | 2 |
| Safety contacts (N/O), delayed | 2 | 2 |
| Max. short circuit current I _K | 1 kA | 1 kA |
| Utilisation category | | |
| In accordance with the standard | EN 60947-4-1 | EN 60947-4-1 |
| Utilisation category of safety contacts | | |
| AC1 at | 240 V | 240 V |
| Min. current | 0,01 A | 0,01 A |
| Max. current | 8 A | 8 A |
| Max. power | 2000 VA | 2000 VA |
| DC1 at | 24 V | 24 V |
| Min. current | 0,01 A | 0,01 A |
| Max. current | 8 A | 8 A |
| Max. power | 200 W | 200 W |

Safety relays PNOZ X PNOZ XV2.1P

| Relay outputs | 777548 | 787540 |
|---|----------------------|----------------------|
| Utilisation category of safety contacts delayed | | |
| AC1 at | 240 V | 240 V |
| Min. current | 0,01 A | 0,01 A |
| Max. current | 8 A | 8 A |
| Max. power | 2000 VA | 2000 VA |
| DC1 at | 24 V | 24 V |
| Min. current | 0,01 A | 0,01 A |
| Max. current | 8 A | 8 A |
| Max. power | 200 W | 200 W |
| Utilisation category | | |
| In accordance with the standard | EN 60947-5-1 | EN 60947-5-1 |
| Utilisation category of safety contacts | | |
| AC15 at | 230 V | 230 V |
| Max. current | 5 A | 5 A |
| DC13 (6 cycles/min) at | 24 V | 24 V |
| Max. current | 7 A | 7 A |
| Utilisation category of safety contacts delayed | | |
| AC15 at | 230 V | 230 V |
| Max. current | 5 A | 5 A |
| DC13 (6 cycles/min) at | 24 V | 24 V |
| Max. current | 7 A | 7 A |
| Utilisation category in accordance with UL | | |
| Voltage | 240 V AC G. P. | 240 V AC G. P. |
| With current | 8 A | 8 A |
| Pilot Duty | C300, R300 | C300, R300 |
| External contact fuse protection, safety contacts | | |
| In accordance with the standard | EN 60947-5-1 | EN 60947-5-1 |
| Max. melting integral | 240 A ² s | 240 A ² s |
| Blow-out fuse, quick | 10 A | 10 A |
| Blow-out fuse, slow | 6 A | 6 A |
| Blow-out fuse, gG | 10 A | 10 A |
| Circuit breaker 24V AC/DC, characteristic B/C | 6 A | 6 A |

Safety relays PNOZ X PNOZ XV2.1P

| Relay outputs | 777548 | 787540 |
|--|--------------------------------|--------------------------------|
| External contact fuse protection, delayed safety contacts | | |
| Max. melting integral | 240 A ² s | 240 A ² s |
| Blow-out fuse, quick | 10 A | 10 A |
| Blow-out fuse, slow | 6 A | 6 A |
| Blow-out fuse, gG | 10 A | 10 A |
| Circuit breaker 24 V AC/DC, characteristic B/C | 6 A | 6 A |
| Contact material | AgSnO ₂ + 0,2 µm Au | AgSnO ₂ + 0,2 µm Au |
| Conventional thermal current while loading several contacts | 777548 | 787540 |
| I _{th} per contact at UB AC; AC1: 240 V, DC1: 24 V | | |
| Conv. therm. current with 1 contact | 8 A | 8 A |
| Conv. therm. current with 2 contacts | 7 A | 7 A |
| Conv. therm. current with 3 contacts | 5,7 A | 5,7 A |
| Conv. therm. current with 4 contacts | 5 A | 5 A |
| I _{th} per contact at UB DC; AC1: 240 V, DC1: 24 V | | |
| Conv. therm. current with 1 contact | 8 A | 8 A |
| Conv. therm. current with 2 contacts | 7 A | 7 A |
| Conv. therm. current with 3 contacts | 5,7 A | 5,7 A |
| Conv. therm. current with 4 contacts | 5 A | 5 A |
| Times | 777548 | 787540 |
| Switch-on delay | | |
| With automatic start typ. | 400 ms | 400 ms |
| With automatic start max. | 550 ms | 550 ms |
| With automatic start after power on typ. | 820 ms | 820 ms |
| With automatic start after power on max. | 1.100 ms | 1.100 ms |
| With monitored start typ. | 35 ms | 35 ms |
| With monitored start max. | 60 ms | 60 ms |

Safety relays PNOZ X PNOZ XV2.1P

| Times | 777548 | 787540 |
|--|---|---|
| Delay-on de-energisation | | |
| With E-STOP typ. | 15 ms | 15 ms |
| With E-STOP max. | 30 ms | 30 ms |
| With power failure typ. UB 240 V | 1 s | 1 s |
| With power failure max. UB 240 V | 1450 ms | 1450 ms |
| With power failure typ. UB 24 V | 130 ms | 130 ms |
| With power failure max. UB 24 V | 170 ms | 170 ms |
| Recovery time at max. switching frequency 1/s | | |
| After E-STOP | 50 ms +tv | 50 ms +tv |
| After power failure on wide-range power supply | 1500 ms | 1500 ms |
| Delay time tv | 0,3 s, 5 s, 10 s, 20 s, 40 s, 60 s, 80 s, 100 s, 150 s, 200 s, 250 s, 300 s | 0,1 s, 0,5 s, 1 s, 2 s, 4 s, 6 s, 8 s, 10 s, 15 s, 20 s, 25 s, 30 s |
| Time accuracy | -15 %/+15 % +50 ms | -15 %/+15 % +50 ms |
| Repetition accuracy | 2 % | 2 % |
| Waiting period with a monitored start | 300 ms | 300 ms |
| Min. start pulse duration with a monitored start | 30 ms | 30 ms |
| Supply interruption before de-energisation | 20 ms | 20 ms |
| Simultaneity, channel 1 and 2 max. | ∞ | ∞ |
| Environmental data | 777548 | 787540 |
| Climatic suitability | EN 60068-2-78 | EN 60068-2-78 |
| Ambient temperature | | |
| Temperature range | -10 - 55 °C | -10 - 55 °C |
| Storage temperature | | |
| Temperature range | -40 - 85 °C | -40 - 85 °C |
| Climatic suitability | | |
| Humidity | 93 % r. h. at 40 °C | 93 % r. h. at 40 °C |
| Condensation during operation | Not permitted | Not permitted |
| EMC | EN 60947-5-1, EN 61000-6-2, EN 61000-6-4, EN 61326-3-1 | EN 60947-5-1, EN 61000-6-2, EN 61000-6-4, EN 61326-3-1 |
| Vibration | | |
| In accordance with the standard | EN 60068-2-6 | EN 60068-2-6 |
| Frequency | 10 - 55 Hz | 10 - 55 Hz |
| Amplitude | 0,35 mm | 0,35 mm |

Safety relays PNOZ X PNOZ XV2.1P

| Environmental data | 777548 | 787540 |
|---|--|---|
| Airgap creepage | | |
| In accordance with the standard | EN 60947-1 | EN 60947-1 |
| Overvoltage category | III / II | III / II |
| Pollution degree | 2 | 2 |
| Rated insulation voltage | 250 V | 250 V |
| Rated impulse withstand voltage | 4 kV | 4 kV |
| Protection type | | |
| Mounting area (e.g. control cabinet) | IP54 | IP54 |
| Housing | IP40 | IP40 |
| Terminals | IP20 | IP20 |
| Mechanical data | 777548 | 787540 |
| Mounting position | Any | Any |
| Mechanical life | 10,000,000 cycles | 10,000,000 cycles |
| Material | | |
| Bottom | PPO UL 94 V0 | PPO UL 94 V0 |
| Front | ABS UL 94 V0 | ABS UL 94 V0 |
| Top | PPO UL 94 V0 | PPO UL 94 V0 |
| Connection type | Screw terminal | Spring-loaded terminal |
| Mounting type | plug-in | plug-in |
| Conductor cross section with screw terminals | | |
| 1 core flexible | 0,25 - 2,5 mm ² , 24 - 12 AWG | – |
| 2 core with the same cross section, flexible with crimp connectors, no plastic sleeve | 0,25 - 1 mm ² , 24 - 16 AWG | – |
| 2 core with the same cross section, flexible without crimp connectors or with TWIN crimp connectors | 0,2 - 1,5 mm ² , 24 - 16 AWG | – |
| Torque setting with screw terminals | 0,5 Nm | – |
| Conductor cross section with spring-loaded terminals: Flexible with/without crimp connector | | |
| | – | 0,2 - 1,5 mm ² , 24 - 16 AWG |
| Spring-loaded terminals: Terminal points per connection | | |
| | – | 2 |
| Stripping length with spring-loaded terminals | | |
| | – | 8 mm |
| Dimensions | | |
| Height | 94 mm | 101 mm |
| Width | 90 mm | 90 mm |
| Depth | 121 mm | 121 mm |
| Weight | 520 g | 515 g |

Safety relays PNOZ X PNOZ XV2.1P

Where standards are undated, the 2014-07 latest editions shall apply.

Order no. 787542 – 787548

| General | 787542 | 787548 |
|--|--|--|
| Approvals | CCC, CE, EAC (Eurasian), TÜV, cULus Listed | CCC, CE, EAC (Eurasian), TÜV, cULus Listed |
| Electrical data | 787542 | 787548 |
| Supply voltage | | |
| Voltage | 24 - 240 V | 24 - 240 V |
| Kind | AC/DC | AC/DC |
| Voltage tolerance | -15 %/+10 % | -15 %/+10 % |
| Output of external power supply (AC) | 8,5 VA | 8,5 VA |
| Output of external power supply (DC) | 5 W | 5 W |
| Frequency range AC | 50 - 60 Hz | 50 - 60 Hz |
| Residual ripple DC | 160 % | 160 % |
| Duty cycle | 100 % | 100 % |
| Inputs | 787542 | 787548 |
| Number | 2 | 2 |
| Voltage at | | |
| Input circuit DC | 24 V | 24 V |
| Start circuit DC | 24 V | 24 V |
| Feedback loop DC | 24 V | 24 V |
| Current at | | |
| Input circuit DC | 35 mA | 35 mA |
| Start circuit DC | 30 mA | 30 mA |
| Feedback loop DC | 3 mA | 3 mA |
| Max. overall cable resistance RI-max | | |
| Single-channel at UB DC | 200 Ohm | 200 Ohm |
| Single-channel at UB AC | 200 Ohm | 200 Ohm |
| Dual-channel with detection of shorts across contacts at UB DC | 20 Ohm | 20 Ohm |
| Dual-channel with detection of shorts across contacts at UB AC | 20 Ohm | 20 Ohm |

Safety relays PNOZ X PNOZ XV2.1P

| Relay outputs | 787542 | 787548 |
|---|--------------|--------------|
| Number of output contacts | | |
| Safety contacts (N/O), instantaneous | 2 | 2 |
| Safety contacts (N/O), delayed | 2 | 2 |
| Max. short circuit current IK | 1 kA | 1 kA |
| Utilisation category | | |
| In accordance with the standard | EN 60947-4-1 | EN 60947-4-1 |
| Utilisation category of safety contacts | | |
| AC1 at | 240 V | 240 V |
| Min. current | 0,01 A | 0,01 A |
| Max. current | 8 A | 8 A |
| Max. power | 2000 VA | 2000 VA |
| DC1 at | 24 V | 24 V |
| Min. current | 0,01 A | 0,01 A |
| Max. current | 8 A | 8 A |
| Max. power | 200 W | 200 W |
| Utilisation category of safety contacts delayed | | |
| AC1 at | 240 V | 240 V |
| Min. current | 0,01 A | 0,01 A |
| Max. current | 8 A | 8 A |
| Max. power | 2000 VA | 2000 VA |
| DC1 at | 24 V | 24 V |
| Min. current | 0,01 A | 0,01 A |
| Max. current | 8 A | 8 A |
| Max. power | 200 W | 200 W |
| Utilisation category | | |
| In accordance with the standard | EN 60947-5-1 | EN 60947-5-1 |
| Utilisation category of safety contacts | | |
| AC15 at | 230 V | 230 V |
| Max. current | 5 A | 5 A |
| DC13 (6 cycles/min) at | 24 V | 24 V |
| Max. current | 7 A | 7 A |
| Utilisation category of safety contacts delayed | | |
| AC15 at | 230 V | 230 V |
| Max. current | 5 A | 5 A |
| DC13 (6 cycles/min) at | 24 V | 24 V |
| Max. current | 7 A | 7 A |

Safety relays PNOZ X PNOZ XV2.1P

| Relay outputs | 787542 | 787548 |
|--|--------------------------------|--------------------------------|
| Utilisation category in accordance with UL | | |
| Voltage | 240 V AC G. P. | 240 V AC G. P. |
| With current | 8 A | 8 A |
| Pilot Duty | C300, R300 | C300, R300 |
| External contact fuse protection, safety contacts | | |
| In accordance with the standard | EN 60947-5-1 | EN 60947-5-1 |
| Max. melting integral | 240 A ² s | 240 A ² s |
| Blow-out fuse, quick | 10 A | 10 A |
| Blow-out fuse, slow | 6 A | 6 A |
| Blow-out fuse, gG | 10 A | 10 A |
| Circuit breaker 24V AC/DC, characteristic B/C | 6 A | 6 A |
| External contact fuse protection, delayed safety contacts | | |
| Max. melting integral | 240 A ² s | 240 A ² s |
| Blow-out fuse, quick | 10 A | 10 A |
| Blow-out fuse, slow | 6 A | 6 A |
| Blow-out fuse, gG | 10 A | 10 A |
| Circuit breaker 24 V AC/DC, characteristic B/C | 6 A | 6 A |
| Contact material | AgSnO ₂ + 0,2 µm Au | AgSnO ₂ + 0,2 µm Au |
| Conventional thermal current while loading several contacts | 787542 | 787548 |
| I _{th} per contact at UB AC; AC1: 240 V, DC1: 24 V | | |
| Conv. therm. current with 1 contact | 8 A | 8 A |
| Conv. therm. current with 2 contacts | 7 A | 7 A |
| Conv. therm. current with 3 contacts | 5,7 A | 5,7 A |
| Conv. therm. current with 4 contacts | 5 A | 5 A |

Safety relays PNOZ X PNOZ XV2.1P

| Conventional thermal current while loading several contacts | 787542 | 787548 |
|--|---|--|
| Ith per contact at UB DC; AC1: 240 V, DC1: 24 V | | |
| Conv. therm. current with 1 contact | 8 A | 8 A |
| Conv. therm. current with 2 contacts | 7 A | 7 A |
| Conv. therm. current with 3 contacts | 5,7 A | 5,7 A |
| Conv. therm. current with 4 contacts | 5 A | 5 A |
| Times | 787542 | 787548 |
| Switch-on delay | | |
| With automatic start typ. | 400 ms | 400 ms |
| With automatic start max. | 550 ms | 550 ms |
| With automatic start after power on typ. | 820 ms | 820 ms |
| With automatic start after power on max. | 1.100 ms | 1.100 ms |
| With monitored start typ. | 35 ms | 35 ms |
| With monitored start max. | 60 ms | 60 ms |
| Delay-on de-energisation | | |
| With E-STOP typ. | 15 ms | 15 ms |
| With E-STOP max. | 30 ms | 30 ms |
| With power failure typ. UB 240 V | 1 s | 1 s |
| With power failure max. UB 240 V | 1450 ms | 1450 ms |
| With power failure typ. UB 24 V | 130 ms | 130 ms |
| With power failure max. UB 24 V | 170 ms | 170 ms |
| Recovery time at max. switching frequency 1/s | | |
| After E-STOP | 50 ms +tv | 50 ms +tv |
| After power failure on wide-range power supply | 1500 ms | 1500 ms |
| Delay time tv | 0,1 s, 0,2 s, 0,3 s, 0,4 s, 0,5 s, 0,6 s, 0,7 s, 0,8 s, 1 s, 1,5 s, 2 s, 3 s | 0,3 s, 5 s, 10 s, 20 s, 40 s, 60 s, 80 s, 100 s, 150 s, 200 s, 250 s, 300 s |
| Time accuracy | -15 %/+15 % +50 ms | -15 %/+15 % +50 ms |
| Repetition accuracy | 2 % | 2 % |
| Waiting period with a monitored start | 300 ms | 300 ms |
| Min. start pulse duration with a monitored start | 30 ms | 30 ms |

Safety relays PNOZ X PNOZ XV2.1P

| Times | 787542 | 787548 |
|---|---|---|
| Supply interruption before de-energisation | 20 ms | 20 ms |
| Simultaneity, channel 1 and 2 max. | ∞ | ∞ |
| Environmental data | 787542 | 787548 |
| Climatic suitability | EN 60068-2-78 | EN 60068-2-78 |
| Ambient temperature | | |
| Temperature range | -10 - 55 °C | -10 - 55 °C |
| Storage temperature | | |
| Temperature range | -40 - 85 °C | -40 - 85 °C |
| Climatic suitability | | |
| Humidity | 93 % r. h. at 40 °C | 93 % r. h. at 40 °C |
| Condensation during operation | Not permitted | Not permitted |
| EMC | EN 60947-5-1, EN 61000-6-2, EN 61000-6-4, EN 61326-3-1 | EN 60947-5-1, EN 61000-6-2, EN 61000-6-4, EN 61326-3-1 |
| Vibration | | |
| In accordance with the standard | EN 60068-2-6 | EN 60068-2-6 |
| Frequency | 10 - 55 Hz | 10 - 55 Hz |
| Amplitude | 0,35 mm | 0,35 mm |
| Airgap creepage | | |
| In accordance with the standard | EN 60947-1 | EN 60947-1 |
| Overvoltage category | III / II | III / II |
| Pollution degree | 2 | 2 |
| Rated insulation voltage | 250 V | 250 V |
| Rated impulse withstand voltage | 4 kV | 4 kV |
| Protection type | | |
| Mounting area (e.g. control cabinet) | IP54 | IP54 |
| Housing | IP40 | IP40 |
| Terminals | IP20 | IP20 |
| Mechanical data | 787542 | 787548 |
| Mounting position | Any | Any |
| Mechanical life | 10,000,000 cycles | 10,000,000 cycles |
| Material | | |
| Bottom | PPO UL 94 V0 | PPO UL 94 V0 |
| Front | ABS UL 94 V0 | ABS UL 94 V0 |
| Top | PPO UL 94 V0 | PPO UL 94 V0 |
| Connection type | Spring-loaded terminal | Spring-loaded terminal |
| Mounting type | plug-in | plug-in |
| Conductor cross section with spring-loaded terminals: Flexible with/without crimp connector | 0,2 - 1,5 mm², 24 - 16 AWG | 0,2 - 1,5 mm², 24 - 16 AWG |

Safety relays PNOZ X PNOZ XV2.1P

| Mechanical data | 787542 | 787548 |
|---|--------|--------|
| Spring-loaded terminals: Terminal points per connection | 2 | 2 |
| Stripping length with spring-loaded terminals | 8 mm | 8 mm |
| Dimensions | | |
| Height | 101 mm | 101 mm |
| Width | 90 mm | 90 mm |
| Depth | 121 mm | 121 mm |
| Weight | 515 g | 515 g |

Where standards are undated, the 2014-07 latest editions shall apply.

Safety characteristic data

| Operating mode | EN ISO 13849-1: 2015 PL | EN ISO 13849-1: 2015 Category | EN 62061 SIL CL | EN 62061 PFH _D [1/h] | EN ISO 13849-1: 2015 T _M [year] |
|--------------------------------|----------------------------|----------------------------------|--------------------|------------------------------------|---|
| Safety contacts, instantaneous | PL e | Cat. 4 | SIL CL 3 | 2,31E-09 | 20 |
| Safety contacts, delayed <30 s | PL d | Cat. 3 | SIL CL 3 | 2,64E-09 | 20 |
| Safety contacts, delayed ≥30 s | PL c | Cat. 1 | SIL CL 1 | 2,87E-09 | 20 |

All the units used within a safety function must be considered when calculating the safety characteristic data.

Supplementary data

The PFH value depends on the switching frequency and the load on the relay output. If the service life graphs are not accessible, the stated PFH value can be used irrespective of the switching frequency and the load, as the PFH value already considers the relay's B10d value as well as the failure rates of the other components.

Safety relays PNOZ X PNOZ XV2.1P

Service life graph

The service life graphs indicate the number of cycles from which failures due to wear must be expected. The wear is mainly caused by the electrical load; the mechanical load is negligible.

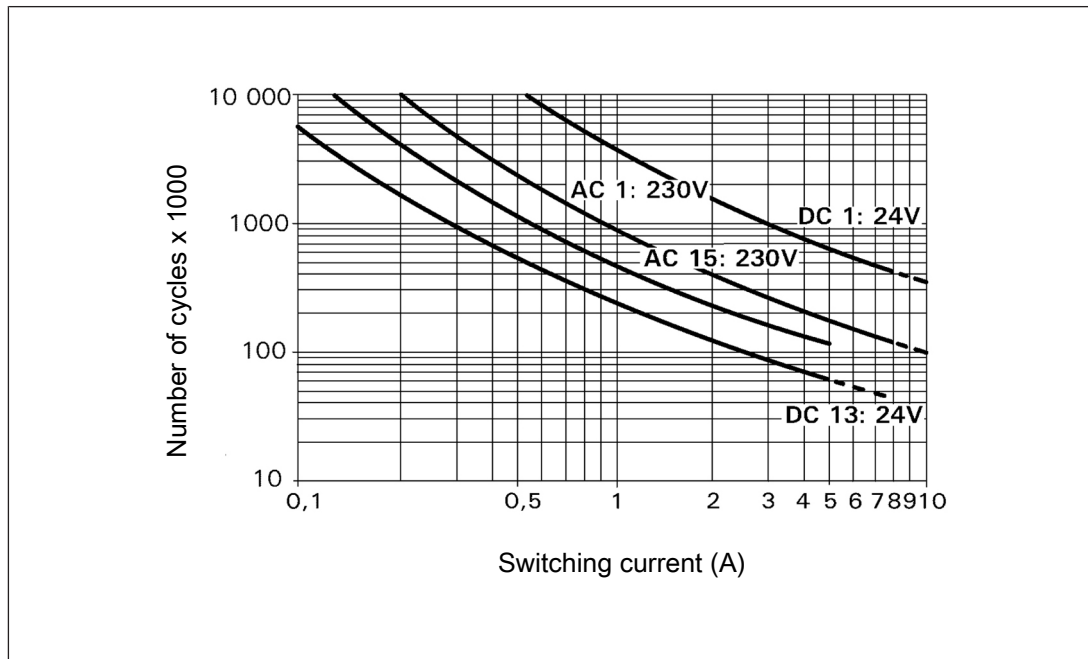

Example

- ▶ Inductive load: 0.2 A
- ▶ Utilisation category: AC15
- ▶ Contact service life: 4 000 000 cycles

Provided the application to be implemented requires fewer than 4 000 000 cycles, the PFH value (see Technical details) can be used in the calculation.

To increase the service life, sufficient spark suppression must be provided on all output contacts. With capacitive loads, any power surges that occur must be noted. With DC contactors, use flywheel diodes for spark suppression.

Safety relays PNOZ X PNOZ XV2.1P

Order reference

| Product type | Features | Connection type | Order no. |
|---------------|---|-------------------------|-----------|
| PNOZ XV2.1P C | 24-240 VAC/DC; Delay: up to 3 s selectable | Spring-loaded terminals | 787 542 |
| PNOZ XV2.1P | 24-240 VAC/DC; Delay: up to 3 s selectable | Screw terminals | 777 542 |
| PNOZ XV2.1P C | 24-240 VAC/DC; Delay: up to 30 s selectable | Spring-loaded terminals | 787 540 |
| PNOZ XV2.1P | 24-240 VAC/DC; Delay: up to 30 s selectable | Screw terminals | 777 540 |
| PNOZ XV2.1P C | 24-240 VAC/DC; Delay: up to 300 s selectable | Spring-loaded terminals | 787 548 |
| PNOZ XV2.1P | 24-240 VAC/DC; Delay: up to 300 s selectable | Screw terminals | 777 548 |
| PNOZ XV2.1P | 24-240 VAC/DC; Delay: 0.5 s fixed | Screw terminals | 777 544 |

Safety relays PNOZ X PNOZ XV3P

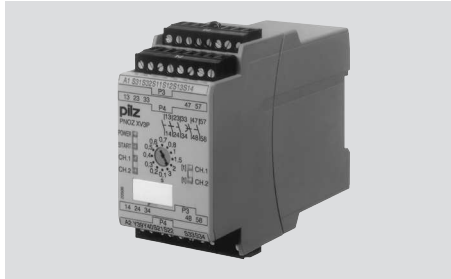

Unit features

- ▶ Positive-guided relay outputs:
 - 3 safety contacts (N/O), instantaneous
 - 2 safety contacts (N/O), delay-on de-energisation
- ▶ Connection options for:
 - E-STOP pushbuttons
 - Safety gate limit switches
 - Start buttons
 - Light grids and safety switches with detection of shorts across contacts
- ▶ Delay time fixed or selectable
- ▶ Possible to cancel delay time
- ▶ LED display for:
 - Supply voltage
 - Switch state of the safety contacts
 - Start circuit
- ▶ Plug-in connection terminals (either spring-loaded terminal or screw terminal)
- ▶ See order reference for unit types

Safety relays PNOZ X PNOZ XV3P

Block diagram/terminal configuration

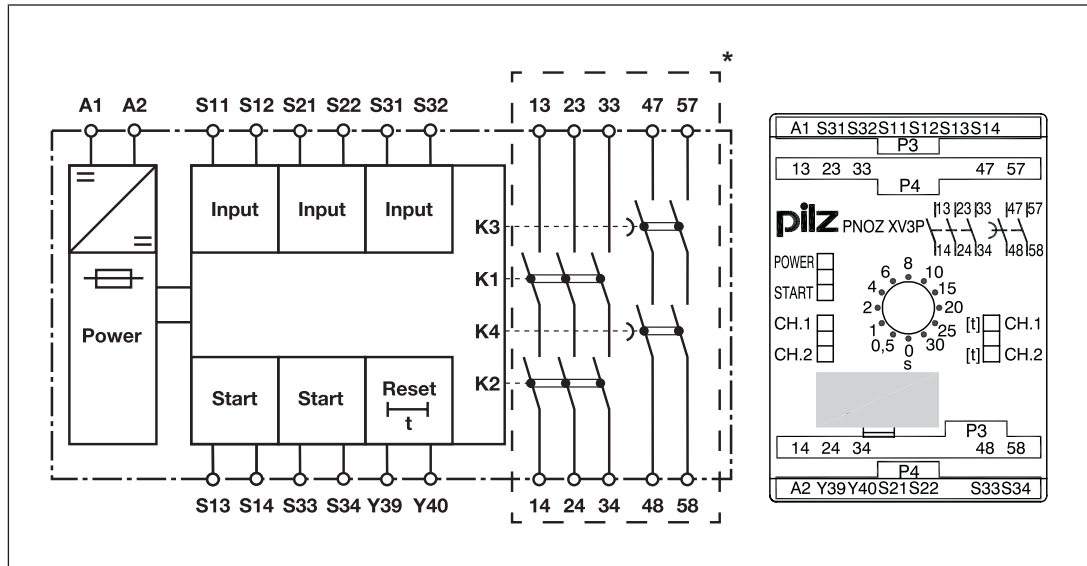

*Insulation between the non-marked area and the relay contacts: Basic insulation (over-voltage category III), Protective separation (overvoltage category II)

Function Description

The safety relay PNOZ XV3P provides a safety-oriented interruption of a safety circuit. When supply voltage is supplied the "POWER" LED is lit. The unit is ready for operation when the reset circuit Y39-Y40 and the start circuit S13-S14 are closed.

- ▶ Input circuit is closed (e.g. E-STOP pushbutton not operated):
 - The "START" LED is lit.
 - The LEDs "CH.1", "CH.1 [t]", "CH.2" and "CH.2 [t]" are lit.
 - Safety contacts 13-14, 23-24, 33-34, 47-48 and 57-58 are closed. The unit is active.
 - The "START" LED goes out.
- ▶ Input circuit is opened (e.g. E-STOP pushbutton operated):
 - The LEDs "CH.1" and "CH.2" go out.
 - Safety contacts 13-14, 23-24 and 33-34 are opened redundantly.
 - Safety contacts 47-48 and 57-58 open after the delay time has elapsed.
 - The LEDs "CH.1 [t]" and "CH.2 [t]" go out.

Before the unit can be restarted, the delay time must have elapsed and the unit must again be ready for operation.

Safety relays PNOZ X PNOZ XV3P

Set delay time:

On units with selectable delay time, the delay time of the safety contacts 47-48 and 57-58 can be set on the front of the unit using a screwdriver.

Reset function:

The delay time cycle can be ended prematurely by opening the reset circuit Y39-Y40. For this purpose, one N/C contact is connected between Y39-Y40 instead of a link.

Operating modes

- ▶ Single-channel operation: No redundancy in the input circuit, earth faults in the start and input circuit are detected.
- ▶ Dual-channel operation with detection of shorts across contacts: Redundant input circuit, detects PNOZ XV3P
 - earth faults in the start and input circuit,
 - short circuits in the input circuit,
 - Shorts across contacts in the input circuit.
- ▶ Dual-channel operation without detection of shorts across contacts: Redundant input circuit, detects PNOZ XV3P
 - earth faults in the start and input circuit,
 - short circuits in the input circuit.
- ▶ Automatic start: Unit is active once the input circuit has been closed.
- ▶ Monitored start: Unit is active once the input circuit is closed and once the start circuit is closed after the waiting period has elapsed (see [Technical details \[352\]](#)).
- ▶ Increase in the number of available contacts by connecting contact expander modules or external contactors/relays.

Safety relays PNOZ X PNOZ XV3P

Timing diagram

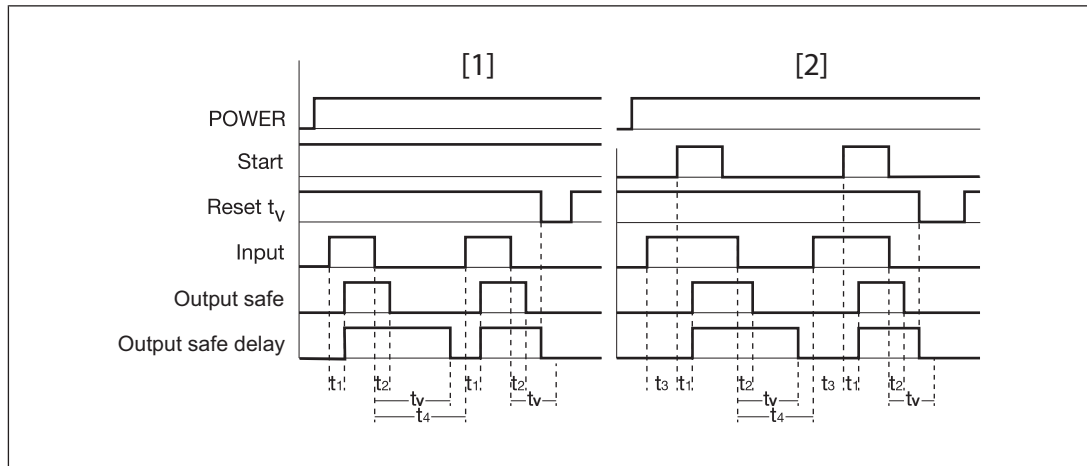

Legend

- ▶ Power: Supply voltage
- ▶ Start: Start circuit
- ▶ Reset t_v : Reset circuit
- ▶ Input: Input circuit
- ▶ Output safe: Safety contacts, instantaneous
- ▶ Output safe delay: Safety contacts, delayed
- ▶ [1]: Automatic start
- ▶ [2]: Monitored start
- ▶ t_1 : Switch-on delay
- ▶ t_2 : Delay-on de-energisation
- ▶ t_3 : Waiting period with a monitored start
- ▶ t_4 : Recovery time
- ▶ t_v : Delay time

Installation

- ▶ The unit should be installed in a control cabinet with a protection type of at least IP54.
- ▶ Use the notch on the rear of the unit to attach it to a DIN rail.
- ▶ Ensure the unit is mounted securely on a vertical DIN rail (35 mm) by using a fixing element (e.g. retaining bracket or an end angle).

Safety relays PNOZ X PNOZ XV3P

Wiring

Please note:

- ▶ Information given in the "[Technical details \[352\]](#)" must be followed.
- ▶ Delivery status of units with screw terminals: Link between S11-S12 (dual-channel input circuit) and link between Y39-Y40 (reset circuit)
- ▶ Outputs 13-14, 23-24, 33-34 are instantaneous safety contacts, outputs 47-48, 57-58 are delay-on de-energisation safety contacts.
- ▶ Do not connect undesignated terminals.
- ▶ To prevent contact welding, a fuse should be connected before the output contacts (see [Technical details \[352\]](#)).
- ▶ Calculation of the max. cable length l_{\max} in the input circuit:

$$l_{\max} = \frac{R_{l_{\max}}}{R_1 / \text{km}}$$

$R_{l_{\max}}$ = max. overall cable resistance (see [Technical details \[352\]](#))

R_1 / km = cable resistance/km

- ▶ Use copper wire that can withstand 60/75 °C.
- ▶ Sufficient fuse protection must be provided on all output contacts with capacitive and inductive loads.
- ▶ Do not switch low currents using contacts that have been used previously with high currents.
- ▶ When connecting magnetically operated, reed proximity switches, ensure that the max. peak inrush current (on the input circuit) does not overload the proximity switch.
- ▶ The power supply must comply with the regulations for extra low voltages with protective electrical separation (SELV, PELV) in accordance with VDE 0100, Part 410.
- ▶ Ensure the wiring and EMC requirements of IEC 60204-1 are met.

Important for detection of shorts across contacts:

As this function for detecting shorts across contacts is not failsafe, it is tested by Pilz during the final control check. If there is a danger of exceeding the cable length, we recommend the following test once the unit is installed:

1. Unit ready for operation (output contacts closed)
2. Short circuit the test terminals S22, S32 for detecting shorts across the inputs.
3. The unit's fuse must be triggered and the output contacts must open. Cable lengths in the scale of the maximum length can delay the fuse triggering for up to 2 minutes.
4. Reset the fuse: Remove the short circuit and switch off the supply voltage for approx. 1 minute.

Safety relays PNOZ X PNOZ XV3P

Preparing for operation

| Supply voltage | AC | DC |
|--|----------------|--------------|
| | | |
| Input circuit | Single-channel | Dual-channel |
| E-STOP without detection of shorts across contacts | | |
| E-STOP with detection of shorts across contacts | | |
| Safety gate without detection of shorts across contacts | | |
| Safety gate with detection of shorts across contacts | | |
| Light guard or safety switch, detection of shorts across contacts via ESPE | | |

Safety relays PNOZ X PNOZ XV3P

| Start circuit | E-STOP wiring Safety gate without start-up test | Safety gate with start-up test |
|-----------------------------------|--|---|
| Automatic start | | <p>Simultaneity S1 and S2: max. 3 s</p> |
| Monitored start | | |
| Reset delay time | Without reset | With reset |
| Link or N/C contact | | |
| Feedback loop | Automatic start | Monitored start |
| Contacts from external contactors | | |

Legend

- ▶ S1/S2: E-STOP/safety gate switch
- ▶ S3: Reset button
- ▶ ↑↑: Switch operated
- ▶ : Gate open
- ▶ : Gate closed

Safety relays PNOZ X PNOZ XV3P

Dimensions in mm

* with spring-loaded terminals

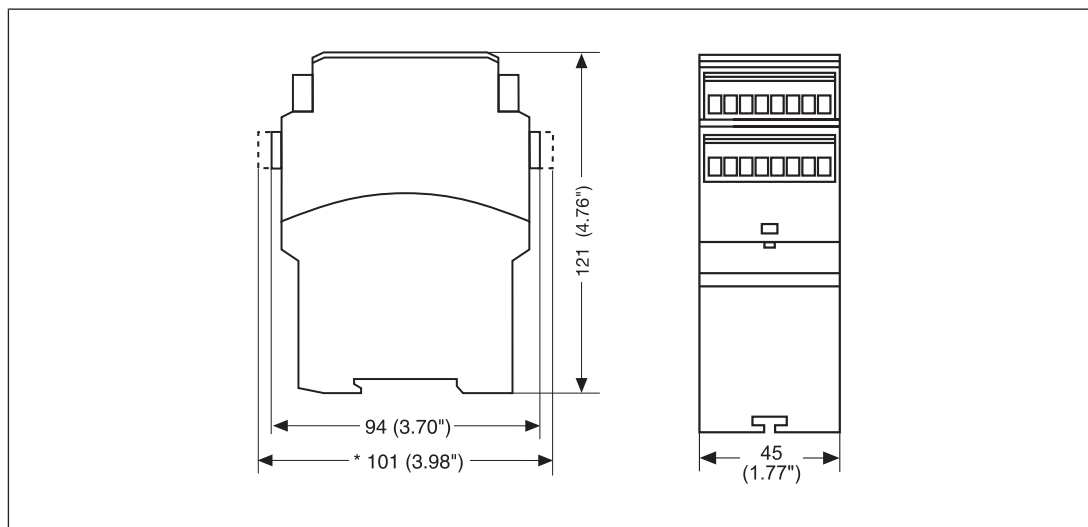

Technical details

Order no. 777510 – 777514

See below for more order numbers

| General | 777510 | 777512 | 777514 |
|--------------------------------------|--|--|--|
| Approvals | CCC, CE, EAC (Eurasian), TÜV, cULus Listed | CCC, CE, EAC (Eurasian), TÜV, cULus Listed | CCC, CE, EAC (Eurasian), TÜV, cULus Listed |
| Electrical data | 777510 | 777512 | 777514 |
| Supply voltage | | | |
| Voltage | 24 V | 24 V | 24 V |
| Kind | DC | DC | DC |
| Voltage tolerance | -15 %/+10 % | -15 %/+10 % | -15 %/+10 % |
| Output of external power supply (DC) | 4,5 W | 4,5 W | 4,5 W |
| Residual ripple DC | 160 % | 160 % | 160 % |
| Duty cycle | 100 % | 100 % | 100 % |
| Max. inrush current impulse | | | |
| Current pulse, A1 | 5 A | 5 A | 5 A |
| Pulse duration, A1 | 1 ms | 1 ms | 1 ms |
| Inputs | 777510 | 777512 | 777514 |
| Number | 2 | 2 | 2 |

Safety relays PNOZ X PNOZ XV3P

| Inputs | 777510 | 777512 | 777514 |
|---|---------------------|---------------------|---------------------|
| Voltage at | | | |
| Input circuit DC | 24 V | 24 V | 24 V |
| Start circuit DC | 24 V | 24 V | 24 V |
| Feedback loop DC | 24 V | 24 V | 24 V |
| Current at | | | |
| Input circuit DC | 35 mA | 35 mA | 35 mA |
| Start circuit DC | 50 mA | 50 mA | 50 mA |
| Feedback loop DC | 3,5 mA | 3,5 mA | 3,5 mA |
| Min. input resistance at power-on | 135 Ohm | 135 Ohm | 135 Ohm |
| Max. overall cable resistance R _{lmax} | | | |
| Single-channel at UB DC | 100 Ohm | 100 Ohm | 100 Ohm |
| Dual-channel without detection of shorts across contacts at UB DC | 100 Ohm | 100 Ohm | 100 Ohm |
| Dual-channel with detection of shorts across contacts at UB DC | 10 Ohm | 10 Ohm | 10 Ohm |
| Relay outputs | 777510 | 777512 | 777514 |
| Number of output contacts | | | |
| Safety contacts (N/O), instantaneous | 3 | 3 | 3 |
| Safety contacts (N/O), delayed | 2 | 2 | 2 |
| Max. short circuit current I _K | 1 kA | 1 kA | 1 kA |
| Utilisation category | | | |
| In accordance with the standard | EN 60947-4-1 | EN 60947-4-1 | EN 60947-4-1 |
| Utilisation category of safety contacts | | | |
| AC1 at | 240 V | 240 V | 240 V |
| Min. current | 0,01 A | 0,01 A | 0,01 A |
| Max. current | 8 A | 8 A | 8 A |
| Max. power | 2000 VA | 2000 VA | 2000 VA |
| DC1 at | 24 V | 24 V | 24 V |
| Min. current | 0,01 A | 0,01 A | 0,01 A |
| Max. current | 8 A | 8 A | 8 A |
| Max. power | 200 W | 200 W | 200 W |

Safety relays PNOZ X PNOZ XV3P

| Relay outputs | 777510 | 777512 | 777514 |
|---|---------------------------|---------------------------|---------------------------|
| Utilisation category of safety contacts delayed | | | |
| AC1 at | 240 V | 240 V | 240 V |
| Min. current | 0,01 A | 0,01 A | 0,01 A |
| Max. current | 8 A | 8 A | 8 A |
| Max. power | 2000 VA | 2000 VA | 2000 VA |
| DC1 at | 24 V | 24 V | 24 V |
| Min. current | 0,01 A | 0,01 A | 0,01 A |
| Max. current | 8 A | 8 A | 8 A |
| Max. power | 200 W | 200 W | 200 W |
| Utilisation category | | | |
| In accordance with the standard | EN 60947-5-1 | EN 60947-5-1 | EN 60947-5-1 |
| Utilisation category of safety contacts | | | |
| AC15 at | 230 V | 230 V | 230 V |
| Max. current | 5 A | 5 A | 5 A |
| DC13 (6 cycles/min) at | 24 V | 24 V | 24 V |
| Max. current | 7 A | 7 A | 7 A |
| Utilisation category of safety contacts delayed | | | |
| AC15 at | 230 V | 230 V | 230 V |
| Max. current | 5 A | 5 A | 5 A |
| DC13 (6 cycles/min) at | 24 V | 24 V | 24 V |
| Max. current | 7 A | 7 A | 7 A |
| Utilisation category in accordance with UL | | | |
| Voltage | 240 V AC G. P. | 240 V AC G. P. | 240 V AC G. P. |
| With current | 8 A | 8 A | 8 A |
| Voltage | 24 V DC Resistive | 24 V DC Resistive | 24 V DC Resistive |
| With current | 5 A | 5 A | 5 A |
| Pilot Duty | C300, R300 | C300, R300 | C300, R300 |
| External contact fuse protection, safety contacts | | | |
| In accordance with the standard | EN 60947-5-1 | EN 60947-5-1 | EN 60947-5-1 |
| Max. melting integral | 240 A²s | 240 A²s | 240 A²s |
| Blow-out fuse, quick | 10 A | 10 A | 10 A |
| Blow-out fuse, slow | 6 A | 6 A | 6 A |
| Blow-out fuse, gG | 10 A | 10 A | 10 A |
| Circuit breaker 24V AC/DC, characteristic B/C | 6 A | 6 A | 6 A |

Safety relays PNOZ X PNOZ XV3P

| Relay outputs | 777510 | 777512 | 777514 |
|--|--------------------------------------|--------------------------------------|--------------------------------------|
| External contact fuse protection, delayed safety contacts | | | |
| Max. melting integral | 240 A²s | 240 A²s | 240 A²s |
| Blow-out fuse, quick | 10 A | 10 A | 10 A |
| Blow-out fuse, slow | 6 A | 6 A | 6 A |
| Blow-out fuse, gG | 10 A | 10 A | 10 A |
| Circuit breaker 24 V AC/DC, characteristic B/C | 6 A | 6 A | 6 A |
| Contact material | AgSnO₂ + 0,2 µm Au | AgSnO₂ + 0,2 µm Au | AgSnO₂ + 0,2 µm Au |
| Conventional thermal current while loading several contacts | 777510 | 777512 | 777514 |
| I _{th} per contact at UB DC; AC1: 240 V, DC1: 24 V | | | |
| Conv. therm. current with 1 contact | 8 A | 8 A | 8 A |
| Conv. therm. current with 2 contacts | 6,8 A | 6,8 A | 6,8 A |
| Conv. therm. current with 3 contacts | 5,5 A | 5,5 A | 5,5 A |
| Conv. therm. current with 4 contacts | 4,8 A | 4,8 A | 4,8 A |
| Conv. therm. current with 5 contacts | 4,3 A | 4,3 A | 4,3 A |
| Times | 777510 | 777512 | 777514 |
| Switch-on delay | | | |
| With automatic start typ. | 350 ms | 350 ms | 350 ms |
| With automatic start max. | 650 ms | 650 ms | 650 ms |
| With automatic start after power on typ. | 385 ms | 385 ms | 385 ms |
| With automatic start after power on max. | 700 ms | 700 ms | 700 ms |
| With monitored start typ. | 35 ms | 35 ms | 35 ms |
| With monitored start max. | 70 ms | 70 ms | 70 ms |

Safety relays PNOZ X PNOZ XV3P

| Times | 777510 | 777512 | 777514 |
|--|---|--|--|
| Delay-on de-energisation | | | |
| With E-STOP typ. | 15 ms | 15 ms | 15 ms |
| With E-STOP max. | 30 ms | 30 ms | 30 ms |
| With power failure typ. | 85 ms | 85 ms | 85 ms |
| With power failure max. | 200 ms | 200 ms | 200 ms |
| Recovery time at max. switching frequency 1/s | | | |
| After E-STOP | 50 ms +tv | 50 ms +tv | 50 ms +tv |
| After power failure | 250 ms | 250 ms | 250 ms |
| Delay time tv | 0,1 s, 0,5 s, 1 s, 2 s, 4 s, 6 s, 8 s, 10 s, 15 s, 20 s, 25 s, 30 s | 0,1 s, 0,2 s, 0,3 s, 0,4 s, 0,5 s, 0,6 s, 0,7 s, 0,8 s, 1 s, 1,5 s, 2 s, 3 s | 0,5 s |
| Time accuracy | -15 %/+15 % +50 ms | -15 %/+15 % +50 ms | -15 %/+15 % +50 ms |
| Repetition accuracy | 2 % | 2 % | 2 % |
| Waiting period with a monitored start | 300 ms | 300 ms | 300 ms |
| Min. start pulse duration with a monitored start | 30 ms | 30 ms | 30 ms |
| Supply interruption before de-energisation | 20 ms | 20 ms | 20 ms |
| Simultaneity, channel 1 and 2 max. | ∞ | ∞ | ∞ |
| Environmental data | 777510 | 777512 | 777514 |
| Climatic suitability | EN 60068-2-78 | EN 60068-2-78 | EN 60068-2-78 |
| Ambient temperature | | | |
| Temperature range | -10 - 55 °C | -10 - 55 °C | -10 - 55 °C |
| Storage temperature | | | |
| Temperature range | -40 - 85 °C | -40 - 85 °C | -40 - 85 °C |
| Climatic suitability | | | |
| Humidity | 93 % r. h. at 40 °C | 93 % r. h. at 40 °C | 93 % r. h. at 40 °C |
| Condensation during operation | Not permitted | Not permitted | Not permitted |
| EMC | EN 60947-5-1, EN 61000-6-2, EN 61326-3-1 | EN 60947-5-1, EN 61000-6-2, EN 61326-3-1 | EN 60947-5-1, EN 61000-6-2, EN 61326-3-1 |
| Vibration | | | |
| In accordance with the standard | EN 60068-2-6 | EN 60068-2-6 | EN 60068-2-6 |
| Frequency | 10 - 55 Hz | 10 - 55 Hz | 10 - 55 Hz |
| Amplitude | 0,35 mm | 0,35 mm | 0,35 mm |

Safety relays PNOZ X PNOZ XV3P

| Environmental data | 777510 | 777512 | 777514 |
|---|--|--|--|
| Airgap creepage | | | |
| In accordance with the standard | EN 60947-1 | EN 60947-1 | EN 60947-1 |
| Overvoltage category | III / II | III / II | III / II |
| Pollution degree | 2 | 2 | 2 |
| Rated insulation voltage | 250 V | 250 V | 250 V |
| Rated impulse withstand voltage | 4 kV | 4 kV | 4 kV |
| Protection type | | | |
| Mounting area (e.g. control cabinet) | IP54 | IP54 | IP54 |
| Housing | IP40 | IP40 | IP40 |
| Terminals | IP20 | IP20 | IP20 |
| Mechanical data | 777510 | 777512 | 777514 |
| Mounting position | Any | Any | Any |
| Mechanical life | 10,000,000 cycles | 10,000,000 cycles | 10,000,000 cycles |
| Material | | | |
| Bottom | PPO UL 94 V0 | PPO UL 94 V0 | PPO UL 94 V0 |
| Front | ABS UL 94 V0 | ABS UL 94 V0 | ABS UL 94 V0 |
| Top | PPO UL 94 V0 | PPO UL 94 V0 | PPO UL 94 V0 |
| Connection type | Screw terminal | Screw terminal | Screw terminal |
| Mounting type | plug-in | plug-in | plug-in |
| Conductor cross section with screw terminals | | | |
| 1 core flexible | 0,25 - 2,5 mm ² , 24 - 12 AWG | 0,25 - 2,5 mm ² , 24 - 12 AWG | 0,25 - 2,5 mm ² , 24 - 12 AWG |
| 2 core with the same cross section, flexible with crimp connectors, no plastic sleeve | 0,25 - 1 mm ² , 24 - 16 AWG | 0,25 - 1 mm ² , 24 - 16 AWG | 0,25 - 1 mm ² , 24 - 16 AWG |
| 2 core with the same cross section, flexible without crimp connectors or with TWIN crimp connectors | 0,2 - 1,5 mm ² , 24 - 16 AWG | 0,2 - 1,5 mm ² , 24 - 16 AWG | 0,2 - 1,5 mm ² , 24 - 16 AWG |
| Torque setting with screw terminals | 0,5 Nm | 0,5 Nm | 0,5 Nm |
| Dimensions | | | |
| Height | 94 mm | 94 mm | 94 mm |
| Width | 45 mm | 45 mm | 45 mm |
| Depth | 121 mm | 121 mm | 121 mm |
| Weight | 370 g | 370 g | 360 g |

Where standards are undated, the 2014-07 latest editions shall apply.

Safety relays PNOZ X PNOZ XV3P

Order no. 777515 – 777518

See below for more order numbers

| General | 777515 | 777517 | 777518 |
|---|--|--|--|
| Approvals | CCC, CE, EAC (Eurasian), TÜV, cULus Listed | CCC, CE, EAC (Eurasian), TÜV, cULus Listed | CCC, CE, EAC (Eurasian), TÜV, cULus Listed |
| Electrical data | 777515 | 777517 | 777518 |
| Supply voltage | | | |
| Voltage | 24 V | 24 V | 24 V |
| Kind | DC | DC | DC |
| Voltage tolerance | -15 %/+10 % | -15 %/+10 % | -15 %/+10 % |
| Output of external power supply (DC) | 4,5 W | 4,5 W | 4,5 W |
| Residual ripple DC | 160 % | 160 % | 160 % |
| Duty cycle | 100 % | 100 % | 100 % |
| Max. inrush current impulse | | | |
| Current pulse, A1 | 5 A | 5 A | 5 A |
| Pulse duration, A1 | 1 ms | 1 ms | 1 ms |
| Inputs | 777515 | 777517 | 777518 |
| Number | 2 | 2 | 2 |
| Voltage at | | | |
| Input circuit DC | 24 V | 24 V | 24 V |
| Start circuit DC | 24 V | 24 V | 24 V |
| Feedback loop DC | 24 V | 24 V | 24 V |
| Current at | | | |
| Input circuit DC | 35 mA | 35 mA | 35 mA |
| Start circuit DC | 50 mA | 50 mA | 50 mA |
| Feedback loop DC | 3,5 mA | 3,5 mA | 3,5 mA |
| Min. input resistance at power-on | 135 Ohm | 135 Ohm | 135 Ohm |
| Max. overall cable resistance R _{lmax} | | | |
| Single-channel at UB DC | 100 Ohm | 100 Ohm | 100 Ohm |
| Dual-channel without detection of shorts across contacts at UB DC | 100 Ohm | 100 Ohm | 100 Ohm |
| Dual-channel with detection of shorts across contacts at UB DC | 10 Ohm | 10 Ohm | 10 Ohm |

Safety relays PNOZ X PNOZ XV3P

| Relay outputs | 777515 | 777517 | 777518 |
|---|--------------|--------------|--------------|
| Number of output contacts | | | |
| Safety contacts (N/O), instantaneous | 3 | 3 | 3 |
| Safety contacts (N/O), delayed | 2 | 2 | 2 |
| Max. short circuit current IK | 1 kA | 1 kA | 1 kA |
| Utilisation category | | | |
| In accordance with the standard | EN 60947-4-1 | EN 60947-4-1 | EN 60947-4-1 |
| Utilisation category of safety contacts | | | |
| AC1 at | 240 V | 240 V | 240 V |
| Min. current | 0,01 A | 0,01 A | 0,01 A |
| Max. current | 8 A | 8 A | 8 A |
| Max. power | 2000 VA | 2000 VA | 2000 VA |
| DC1 at | 24 V | 24 V | 24 V |
| Min. current | 0,01 A | 0,01 A | 0,01 A |
| Max. current | 8 A | 8 A | 8 A |
| Max. power | 200 W | 200 W | 200 W |
| Utilisation category of safety contacts delayed | | | |
| AC1 at | 240 V | 240 V | 240 V |
| Min. current | 0,01 A | 0,01 A | 0,01 A |
| Max. current | 8 A | 8 A | 8 A |
| Max. power | 2000 VA | 2000 VA | 2000 VA |
| DC1 at | 24 V | 24 V | 24 V |
| Min. current | 0,01 A | 0,01 A | 0,01 A |
| Max. current | 8 A | 8 A | 8 A |
| Max. power | 200 W | 200 W | 200 W |
| Utilisation category | | | |
| In accordance with the standard | EN 60947-5-1 | EN 60947-5-1 | EN 60947-5-1 |
| Utilisation category of safety contacts | | | |
| AC15 at | 230 V | 230 V | 230 V |
| Max. current | 5 A | 5 A | 5 A |
| DC13 (6 cycles/min) at | 24 V | 24 V | 24 V |
| Max. current | 7 A | 7 A | 7 A |

Safety relays PNOZ X PNOZ XV3P

| Relay outputs | 777515 | 777517 | 777518 |
|---|--------------------------------------|--------------------------------------|--------------------------------------|
| Utilisation category of safety contacts delayed | | | |
| AC15 at | 230 V | 230 V | 230 V |
| Max. current | 5 A | 5 A | 5 A |
| DC13 (6 cycles/min) at | 24 V | 24 V | 24 V |
| Max. current | 7 A | 7 A | 7 A |
| Utilisation category in accordance with UL | | | |
| Voltage | 240 V AC G. P. | 240 V AC G. P. | 240 V AC G. P. |
| With current | 8 A | 8 A | 8 A |
| Voltage | 24 V DC Resistive | 24 V DC Resistive | 24 V DC Resistive |
| With current | 5 A | 5 A | 5 A |
| Pilot Duty | C300, R300 | C300, R300 | C300, R300 |
| External contact fuse protection, safety contacts | | | |
| In accordance with the standard | EN 60947-5-1 | EN 60947-5-1 | EN 60947-5-1 |
| Max. melting integral | 240 A²s | 240 A²s | 240 A²s |
| Blow-out fuse, quick | 10 A | 10 A | 10 A |
| Blow-out fuse, slow | 6 A | 6 A | 6 A |
| Blow-out fuse, gG | 10 A | 10 A | 10 A |
| Circuit breaker 24V AC/DC, characteristic B/C | 6 A | 6 A | 6 A |
| External contact fuse protection, delayed safety contacts | | | |
| Max. melting integral | 240 A²s | 240 A²s | 240 A²s |
| Blow-out fuse, quick | 10 A | 10 A | 10 A |
| Blow-out fuse, slow | 6 A | 6 A | 6 A |
| Blow-out fuse, gG | 10 A | 10 A | 10 A |
| Circuit breaker 24 V AC/DC, characteristic B/C | 6 A | 6 A | 6 A |
| Contact material | AgSnO₂ + 0,2 µm Au | AgSnO₂ + 0,2 µm Au | AgSnO₂ + 0,2 µm Au |

Safety relays PNOZ X PNOZ XV3P

| Conventional thermal current while loading several contacts | 777515 | 777517 | 777518 |
|--|---------------------------|---------------------------|--|
| Ith per contact at UB DC; AC1: 240 V, DC1: 24 V | | | |
| Conv. therm. current with 1 contact | 8 A | 8 A | 8 A |
| Conv. therm. current with 2 contacts | 6,8 A | 6,8 A | 6,8 A |
| Conv. therm. current with 3 contacts | 5,5 A | 5,5 A | 5,5 A |
| Conv. therm. current with 4 contacts | 4,8 A | 4,8 A | 4,8 A |
| Conv. therm. current with 5 contacts | 4,3 A | 4,3 A | 4,3 A |
| Times | 777515 | 777517 | 777518 |
| Switch-on delay | | | |
| With automatic start typ. | 350 ms | 350 ms | 350 ms |
| With automatic start max. | 650 ms | 650 ms | 650 ms |
| With automatic start after power on typ. | 385 ms | 385 ms | 385 ms |
| With automatic start after power on max. | 700 ms | 700 ms | 700 ms |
| With monitored start typ. | 35 ms | 35 ms | 35 ms |
| With monitored start max. | 70 ms | 70 ms | 70 ms |
| Delay-on de-energisation | | | |
| With E-STOP typ. | 15 ms | 15 ms | 15 ms |
| With E-STOP max. | 30 ms | 30 ms | 30 ms |
| With power failure typ. | 85 ms | 85 ms | 85 ms |
| With power failure max. | 200 ms | 200 ms | 200 ms |
| Recovery time at max. switching frequency 1/s | | | |
| After E-STOP | 50 ms +tv | 50 ms +tv | 50 ms +tv |
| After power failure | 250 ms | 250 ms | 250 ms |
| Delay time tv | 3 s | 10 s | 0,3 s, 5 s, 10 s, 20 s, 40 s, 60 s, 80 s, 100 s, 150 s, 200 s, 250 s, 300 s |
| Time accuracy | -15 %/+15 % +50 ms | -15 %/+15 % +50 ms | -15 %/+15 % +50 ms |
| Repetition accuracy | 2 % | 2 % | 2 % |
| Waiting period with a monitored start | 300 ms | 300 ms | 300 ms |

Safety relays PNOZ X PNOZ XV3P

| Times | 777515 | 777517 | 777518 |
|--|--|--|--|
| Min. start pulse duration with a monitored start | 30 ms | 30 ms | 30 ms |
| Supply interruption before de-energisation | 20 ms | 20 ms | 20 ms |
| Simultaneity, channel 1 and 2 max. | ∞ | ∞ | ∞ |
| Environmental data | 777515 | 777517 | 777518 |
| Climatic suitability | EN 60068-2-78 | EN 60068-2-78 | EN 60068-2-78 |
| Ambient temperature | | | |
| Temperature range | -10 - 55 °C | -10 - 55 °C | -10 - 55 °C |
| Storage temperature | | | |
| Temperature range | -40 - 85 °C | -40 - 85 °C | -40 - 85 °C |
| Climatic suitability | | | |
| Humidity | 93 % r. h. at 40 °C | 93 % r. h. at 40 °C | 93 % r. h. at 40 °C |
| Condensation during operation | Not permitted | Not permitted | Not permitted |
| EMC | EN 60947-5-1, EN 61000-6-2, EN 61326-3-1 | EN 60947-5-1, EN 61000-6-2, EN 61326-3-1 | EN 60947-5-1, EN 61000-6-2, EN 61326-3-1 |
| Vibration | | | |
| In accordance with the standard | EN 60068-2-6 | EN 60068-2-6 | EN 60068-2-6 |
| Frequency | 10 - 55 Hz | 10 - 55 Hz | 10 - 55 Hz |
| Amplitude | 0,35 mm | 0,35 mm | 0,35 mm |
| Airgap creepage | | | |
| In accordance with the standard | EN 60947-1 | EN 60947-1 | EN 60947-1 |
| Overvoltage category | III / II | III / II | III / II |
| Pollution degree | 2 | 2 | 2 |
| Rated insulation voltage | 250 V | 250 V | 250 V |
| Rated impulse withstand voltage | 4 kV | 4 kV | 4 kV |
| Protection type | | | |
| Mounting area (e.g. control cabinet) | IP54 | IP54 | IP54 |
| Housing | IP40 | IP40 | IP40 |
| Terminals | IP20 | IP20 | IP20 |
| Mechanical data | 777515 | 777517 | 777518 |
| Mounting position | Any | Any | Any |
| Mechanical life | 10,000,000 cycles | 10,000,000 cycles | 10,000,000 cycles |

Safety relays PNOZ X PNOZ XV3P

| Mechanical data | 777515 | 777517 | 777518 |
|---|--|--|--|
| Material | | | |
| Bottom | PPO UL 94 V0 | PPO UL 94 V0 | PPO UL 94 V0 |
| Front | ABS UL 94 V0 | ABS UL 94 V0 | ABS UL 94 V0 |
| Top | PPO UL 94 V0 | PPO UL 94 V0 | PPO UL 94 V0 |
| Connection type | Screw terminal | Screw terminal | Screw terminal |
| Mounting type | plug-in | plug-in | plug-in |
| Conductor cross section with screw terminals | | | |
| 1 core flexible | 0,25 - 2,5 mm ² , 24 - 12 AWG | 0,25 - 2,5 mm ² , 24 - 12 AWG | 0,25 - 2,5 mm ² , 24 - 12 AWG |
| 2 core with the same cross section, flexible with crimp connectors, no plastic sleeve | 0,25 - 1 mm ² , 24 - 16 AWG | 0,25 - 1 mm ² , 24 - 16 AWG | 0,25 - 1 mm ² , 24 - 16 AWG |
| 2 core with the same cross section, flexible without crimp connectors or with TWIN crimp connectors | 0,2 - 1,5 mm ² , 24 - 16 AWG | 0,2 - 1,5 mm ² , 24 - 16 AWG | 0,2 - 1,5 mm ² , 24 - 16 AWG |
| Torque setting with screw terminals | 0,5 Nm | 0,5 Nm | 0,5 Nm |
| Dimensions | | | |
| Height | 94 mm | 94 mm | 94 mm |
| Width | 45 mm | 45 mm | 45 mm |
| Depth | 121 mm | 121 mm | 121 mm |
| Weight | 360 g | 360 g | 370 g |

Where standards are undated, the 2014-07 latest editions shall apply.

Order no. 787510 – 787518

| General | 787510 | 787512 | 787518 |
|--------------------------------------|--|--|--|
| Approvals | CCC, CE, EAC (Eurasian), TÜV, cULus Listed | CCC, CE, EAC (Eurasian), TÜV, cULus Listed | CCC, CE, EAC (Eurasian), TÜV, cULus Listed |
| Electrical data | 787510 | 787512 | 787518 |
| Supply voltage | | | |
| Voltage | 24 V | 24 V | 24 V |
| Kind | DC | DC | DC |
| Voltage tolerance | -15 %/+10 % | -15 %/+10 % | -15 %/+10 % |
| Output of external power supply (DC) | 4,5 W | 4,5 W | 4,5 W |
| Residual ripple DC | 160 % | 160 % | 160 % |

Safety relays PNOZ X PNOZ XV3P

| Electrical data | 787510 | 787512 | 787518 |
|---|---------------|---------------|---------------|
| Duty cycle | 100 % | 100 % | 100 % |
| Max. inrush current im-pulse | | | |
| Current pulse, A1 | 5 A | 5 A | 5 A |
| Pulse duration, A1 | 1 ms | 1 ms | 1 ms |
| Inputs | 787510 | 787512 | 787518 |
| Number | 2 | 2 | 2 |
| Voltage at | | | |
| Input circuit DC | 24 V | 24 V | 24 V |
| Start circuit DC | 24 V | 24 V | 24 V |
| Feedback loop DC | 24 V | 24 V | 24 V |
| Current at | | | |
| Input circuit DC | 35 mA | 35 mA | 35 mA |
| Start circuit DC | 50 mA | 50 mA | 50 mA |
| Feedback loop DC | 3,5 mA | 3,5 mA | 3,5 mA |
| Min. input resistance at power-on | 135 Ohm | 135 Ohm | 135 Ohm |
| Max. overall cable resistance R _{lmax} | | | |
| Single-channel at UB DC | 100 Ohm | 100 Ohm | 100 Ohm |
| Dual-channel without detection of shorts across contacts at UB DC | 100 Ohm | 100 Ohm | 100 Ohm |
| Dual-channel with de-tection of shorts across contacts at UB DC | 10 Ohm | 10 Ohm | 10 Ohm |
| Relay outputs | 787510 | 787512 | 787518 |
| Number of output con-tacts | | | |
| Safety contacts (N/O), instantaneous | 3 | 3 | 3 |
| Safety contacts (N/O), delayed | 2 | 2 | 2 |
| Max. short circuit current I _K | 1 kA | 1 kA | 1 kA |
| Utilisation category | | | |
| In accordance with the standard | EN 60947-4-1 | EN 60947-4-1 | EN 60947-4-1 |

Safety relays PNOZ X PNOZ XV3P

| Relay outputs | 787510 | 787512 | 787518 |
|---|--------------------------|--------------------------|--------------------------|
| Utilisation category of safety contacts | | | |
| AC1 at | 240 V | 240 V | 240 V |
| Min. current | 0,01 A | 0,01 A | 0,01 A |
| Max. current | 8 A | 8 A | 8 A |
| Max. power | 2000 VA | 2000 VA | 2000 VA |
| DC1 at | 24 V | 24 V | 24 V |
| Min. current | 0,01 A | 0,01 A | 0,01 A |
| Max. current | 8 A | 8 A | 8 A |
| Max. power | 200 W | 200 W | 200 W |
| Utilisation category of safety contacts delayed | | | |
| AC1 at | 240 V | 240 V | 240 V |
| Min. current | 0,01 A | 0,01 A | 0,01 A |
| Max. current | 8 A | 8 A | 8 A |
| Max. power | 2000 VA | 2000 VA | 2000 VA |
| DC1 at | 24 V | 24 V | 24 V |
| Min. current | 0,01 A | 0,01 A | 0,01 A |
| Max. current | 8 A | 8 A | 8 A |
| Max. power | 200 W | 200 W | 200 W |
| Utilisation category In accordance with the standard | | | |
| | EN 60947-5-1 | EN 60947-5-1 | EN 60947-5-1 |
| Utilisation category of safety contacts | | | |
| AC15 at | 230 V | 230 V | 230 V |
| Max. current | 5 A | 5 A | 5 A |
| DC13 (6 cycles/min) at | 24 V | 24 V | 24 V |
| Max. current | 7 A | 7 A | 7 A |
| Utilisation category of safety contacts delayed | | | |
| AC15 at | 230 V | 230 V | 230 V |
| Max. current | 5 A | 5 A | 5 A |
| DC13 (6 cycles/min) at | 24 V | 24 V | 24 V |
| Max. current | 7 A | 7 A | 7 A |
| Utilisation category in accordance with UL | | | |
| Voltage | 240 V AC G. P. | 240 V AC G. P. | 240 V AC G. P. |
| With current | 8 A | 8 A | 8 A |
| Voltage | 24 V DC Resistive | 24 V DC Resistive | 24 V DC Resistive |
| With current | 5 A | 5 A | 5 A |
| Pilot Duty | C300, R300 | C300, R300 | C300, R300 |

Safety relays PNOZ X PNOZ XV3P

| Relay outputs | 787510 | 787512 | 787518 |
|--|--------------------------------------|--------------------------------------|--------------------------------------|
| External contact fuse protection, safety contacts | | | |
| In accordance with the standard | EN 60947-5-1 | EN 60947-5-1 | EN 60947-5-1 |
| Max. melting integral | 240 A²s | 240 A²s | 240 A²s |
| Blow-out fuse, quick | 10 A | 10 A | 10 A |
| Blow-out fuse, slow | 6 A | 6 A | 6 A |
| Blow-out fuse, gG | 10 A | 10 A | 10 A |
| Circuit breaker 24V AC/DC, characteristic B/C | 6 A | 6 A | 6 A |
| External contact fuse protection, delayed safety contacts | | | |
| Max. melting integral | 240 A²s | 240 A²s | 240 A²s |
| Blow-out fuse, quick | 10 A | 10 A | 10 A |
| Blow-out fuse, slow | 6 A | 6 A | 6 A |
| Blow-out fuse, gG | 10 A | 10 A | 10 A |
| Circuit breaker 24 V AC/DC, characteristic B/C | 6 A | 6 A | 6 A |
| Contact material | AgSnO₂ + 0,2 μm Au | AgSnO₂ + 0,2 μm Au | AgSnO₂ + 0,2 μm Au |
| Conventional thermal current while loading several contacts | 787510 | 787512 | 787518 |
| I _{th} per contact at UB DC; AC1: 240 V, DC1: 24 V | | | |
| Conv. therm. current with 1 contact | 8 A | 8 A | 8 A |
| Conv. therm. current with 2 contacts | 6,8 A | 6,8 A | 6,8 A |
| Conv. therm. current with 3 contacts | 5,5 A | 5,5 A | 5,5 A |
| Conv. therm. current with 4 contacts | 4,8 A | 4,8 A | 4,8 A |
| Conv. therm. current with 5 contacts | 4,3 A | 4,3 A | 4,3 A |

Safety relays PNOZ X PNOZ XV3P

| Times | 787510 | 787512 | 787518 |
|--|---|--|---|
| Switch-on delay | | | |
| With automatic start typ. | 350 ms | 350 ms | 350 ms |
| With automatic start max. | 650 ms | 650 ms | 650 ms |
| With automatic start after power on typ. | 385 ms | 385 ms | 385 ms |
| With automatic start after power on max. | 700 ms | 700 ms | 700 ms |
| With monitored start typ. | 35 ms | 35 ms | 35 ms |
| With monitored start max. | 70 ms | 70 ms | 70 ms |
| Delay-on de-energisation | | | |
| With E-STOP typ. | 15 ms | 15 ms | 15 ms |
| With E-STOP max. | 30 ms | 30 ms | 30 ms |
| With power failure typ. | 85 ms | 85 ms | 85 ms |
| With power failure max. | 200 ms | 200 ms | 200 ms |
| Recovery time at max. switching frequency 1/s | | | |
| After E-STOP | 50 ms +tv | 50 ms +tv | 50 ms +tv |
| After power failure | 250 ms | 250 ms | 250 ms |
| Delay time tv | 0,1 s, 0,5 s, 1 s, 2 s, 4 s, 6 s, 8 s, 10 s, 15 s, 20 s, 25 s, 30 s | 0,1 s, 0,2 s, 0,3 s, 0,4 s, 0,5 s, 0,6 s, 0,7 s, 0,8 s, 1 s, 1,5 s, 2 s, 3 s | 0,3 s, 5 s, 10 s, 20 s, 40 s, 60 s, 80 s, 100 s, 150 s, 200 s, 250 s, 300 s |
| Time accuracy | -15 %/+15 % +50 ms | -15 %/+15 % +50 ms | -15 %/+15 % +50 ms |
| Repetition accuracy | 2 % | 2 % | 2 % |
| Waiting period with a monitored start | 300 ms | 300 ms | 300 ms |
| Min. start pulse duration with a monitored start | 30 ms | 30 ms | 30 ms |
| Supply interruption before de-energisation | 20 ms | 20 ms | 20 ms |
| Simultaneity, channel 1 and 2 max. | ∞ | ∞ | ∞ |
| Environmental data | | | |
| Climatic suitability | EN 60068-2-78 | EN 60068-2-78 | EN 60068-2-78 |
| Ambient temperature | | | |
| Temperature range | -10 - 55 °C | -10 - 55 °C | -10 - 55 °C |
| Storage temperature | | | |
| Temperature range | -40 - 85 °C | -40 - 85 °C | -40 - 85 °C |
| Climatic suitability | | | |
| Humidity | 93 % r. h. at 40 °C | 93 % r. h. at 40 °C | 93 % r. h. at 40 °C |

Safety relays PNOZ X PNOZ XV3P

| Environmental data | 787510 | 787512 | 787518 |
|---|--|--|--|
| Condensation during operation | Not permitted | Not permitted | Not permitted |
| EMC | EN 60947-5-1, EN 61000-6-2, EN 61326-3-1 | EN 60947-5-1, EN 61000-6-2, EN 61326-3-1 | EN 60947-5-1, EN 61000-6-2, EN 61326-3-1 |
| Vibration | | | |
| In accordance with the standard | EN 60068-2-6 | EN 60068-2-6 | EN 60068-2-6 |
| Frequency | 10 - 55 Hz | 10 - 55 Hz | 10 - 55 Hz |
| Amplitude | 0,35 mm | 0,35 mm | 0,35 mm |
| Airgap creepage | | | |
| In accordance with the standard | EN 60947-1 | EN 60947-1 | EN 60947-1 |
| Overvoltage category | III / II | III / II | III / II |
| Pollution degree | 2 | 2 | 2 |
| Rated insulation voltage | 250 V | 250 V | 250 V |
| Rated impulse withstand voltage | 4 kV | 4 kV | 4 kV |
| Protection type | | | |
| Mounting area (e.g. control cabinet) | IP54 | IP54 | IP54 |
| Housing | IP40 | IP40 | IP40 |
| Terminals | IP20 | IP20 | IP20 |
| Mechanical data | 787510 | 787512 | 787518 |
| Mounting position | Any | Any | Any |
| Mechanical life | 10,000,000 cycles | 10,000,000 cycles | 10,000,000 cycles |
| Material | | | |
| Bottom | PPO UL 94 V0 | PPO UL 94 V0 | PPO UL 94 V0 |
| Front | ABS UL 94 V0 | ABS UL 94 V0 | ABS UL 94 V0 |
| Top | PPO UL 94 V0 | PPO UL 94 V0 | PPO UL 94 V0 |
| Connection type | Spring-loaded terminal | Spring-loaded terminal | Spring-loaded terminal |
| Mounting type | plug-in | plug-in | plug-in |
| Conductor cross section with spring-loaded terminals: Flexible with/without crimp connector | 0,2 - 1,5 mm ² , 24 - 16 AWG | 0,2 - 1,5 mm ² , 24 - 16 AWG | 0,2 - 1,5 mm ² , 24 - 16 AWG |
| Spring-loaded terminals: Terminal points per connection | 2 | 2 | 2 |
| Stripping length with spring-loaded terminals | 8 mm | 8 mm | 8 mm |

Safety relays PNOZ X PNOZ XV3P

| Mechanical data | 787510 | 787512 | 787518 |
|-----------------|--------|--------|--------|
| Dimensions | | | |
| Height | 101 mm | 101 mm | 101 mm |
| Width | 45 mm | 45 mm | 45 mm |
| Depth | 121 mm | 121 mm | 121 mm |
| Weight | 370 g | 370 g | 370 g |

Where standards are undated, the 2014-07 latest editions shall apply.

Safety characteristic data

| Operating mode | EN ISO 13849-1: 2015 PL | EN ISO 13849-1: 2015 Category | EN 62061 SIL CL | EN 62061 PFH _D [1/h] | EN ISO 13849-1: 2015 T _M [year] |
|--------------------------------|----------------------------|----------------------------------|--------------------|------------------------------------|---|
| Safety contacts, instantaneous | PL e | Cat. 4 | SIL CL 3 | 2,31E-09 | 20 |
| Safety contacts, delayed <30 s | PL d | Cat. 3 | SIL CL 3 | 2,64E-09 | 20 |
| Safety contacts, delayed ≥30 s | PL c | Cat. 1 | SIL CL 1 | 2,87E-09 | 20 |

All the units used within a safety function must be considered when calculating the safety characteristic data.

Supplementary data

The PFH value depends on the switching frequency and the load on the relay output. If the service life graphs are not accessible, the stated PFH value can be used irrespective of the switching frequency and the load, as the PFH value already considers the relay's B10d value as well as the failure rates of the other components.

Safety relays PNOZ X PNOZ XV3P

Service life graph

The service life graphs indicate the number of cycles from which failures due to wear must be expected. The wear is mainly caused by the electrical load; the mechanical load is negligible.

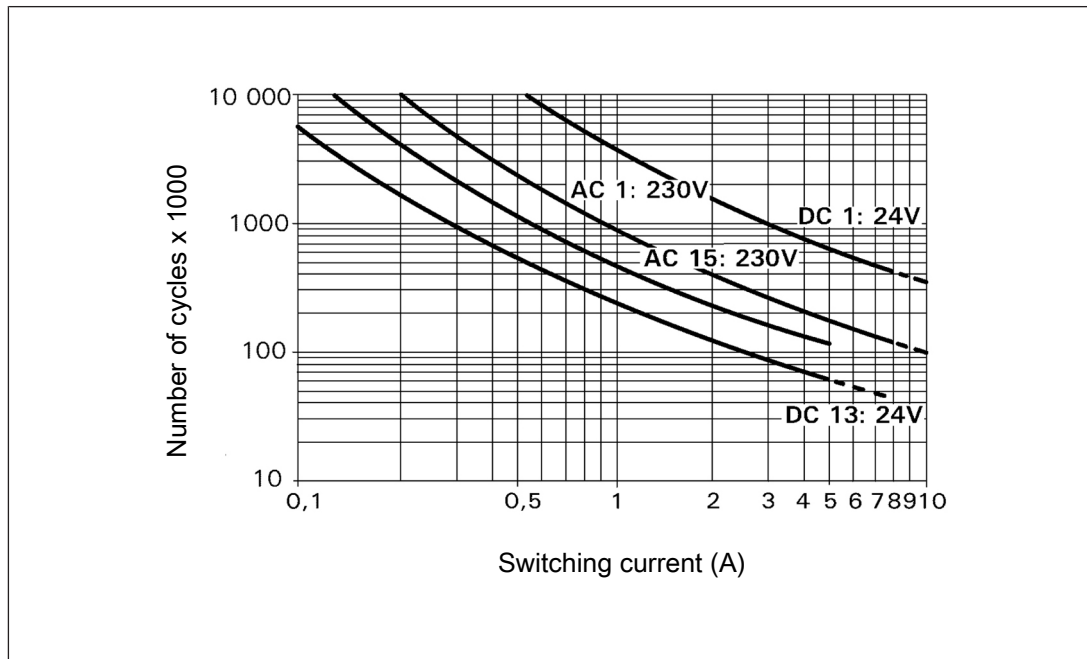

Example

- ▶ Inductive load: 0.2 A
- ▶ Utilisation category: AC15
- ▶ Contact service life: 4 000 000 cycles

Provided the application to be implemented requires fewer than 4 000 000 cycles, the PFH value (see Technical details) can be used in the calculation.

To increase the service life, sufficient spark suppression must be provided on all output contacts. With capacitive loads, any power surges that occur must be noted. With DC contactors, use flywheel diodes for spark suppression.

Safety relays PNOZ X PNOZ XV3P

Order reference

| Product type | Features | Connection type | Order no. |
|--------------|--|-------------------------|-----------|
| PNOZ XV3P | 24 VDC; Delay: 0.5 s fixed | Screw terminals | 777 514 |
| PNOZ XV3P | 24 VDC; Delay: 3 s fixed | Screw terminals | 777 515 |
| PNOZ XV3P | 24 VDC; Delay: 10 s fixed | Screw terminals | 777 517 |
| PNOZ XV3P C | 24 VDC; Delay: up to 3 s selectable | Spring-loaded terminals | 787 512 |
| PNOZ XV3P | 24 VDC; Delay: up to 3 s selectable | Screw terminals | 777 512 |
| PNOZ XV3P C | 24 VDC; Delay: up to 30 s selectable | Spring-loaded terminals | 787 510 |
| PNOZ XV3P | 24 VDC; Delay: up to 30 s selectable | Screw terminals | 777 510 |
| PNOZ XV3P C | 24 VDC; Delay: up to 300 s selectable | Spring-loaded terminals | 787 518 |
| PNOZ XV3P | 24 VDC; Delay: up to 300 s selectable | Screw terminals | 777 518 |

Safety relays PNOZ X PNOZ XV3.1P

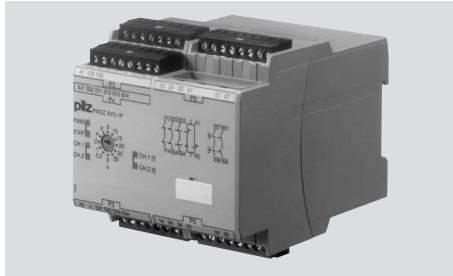

Unit features

- ▶ Positive-guided relay outputs:
 - 3 safety contacts (N/O), instantaneous
 - 2 safety contacts (N/O), delay-on de-energisation
 - 1 auxiliary contact (N/C), instantaneous
- ▶ Connection options for:
 - E-STOP pushbuttons
 - Safety gate limit switches
 - Start buttons
 - Light grids and safety switches with detection of shorts across contacts
- ▶ Delay time fixed or selectable
- ▶ Possible to cancel delay time
- ▶ LED display for:
 - Supply voltage
 - Switch state of the safety contacts
 - Start circuit
- ▶ Plug-in connection terminals (either spring-loaded terminal or screw terminal)
- ▶ See order reference for unit types

Safety relays PNOZ X PNOZ XV3.1P

Block diagram/terminal configuration

Types: AC/DC

- ▶ U_B : 24 - 240 VAC/DC; Order no. 777530, 787530, 777532, 787532, 777538, 787538

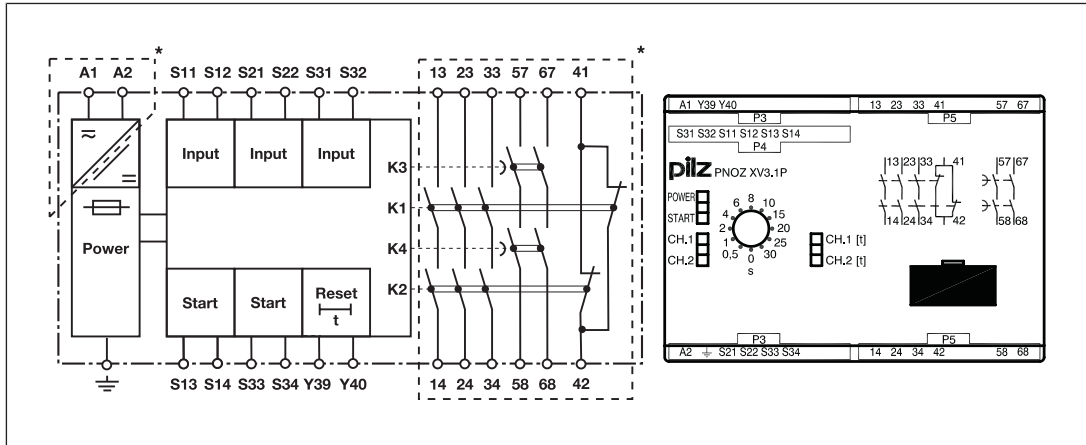

*Insulation between the non-marked area and the relay contacts: Basic insulation (over-voltage category III), Protective separation (overvoltage category II)

Types: DC

- ▶ U_B : 24 VDC; Order no. 777520, 787520, 777522, 787522, 777525

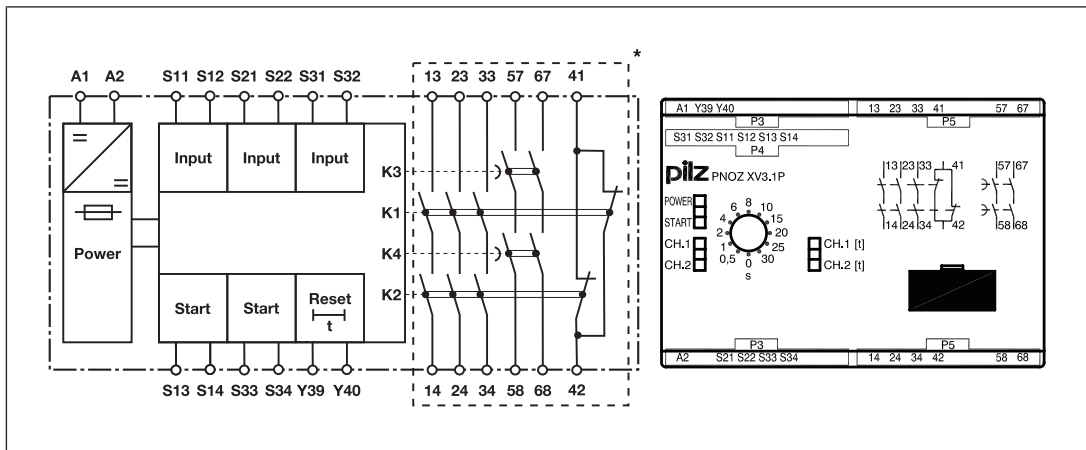

*Insulation between the non-marked area and the relay contacts: Basic insulation (over-voltage category III), Protective separation (overvoltage category II)

Safety relays PNOZ X PNOZ XV3.1P

Function Description

The safety relay PNOZ XV3.1P provides a safety-oriented interruption of a safety circuit. When supply voltage is supplied the "POWER" LED is lit. The unit is ready for operation when the reset circuit Y39-Y40 and the start circuit S13-S14 are closed.

- ▶ Input circuit is closed (e.g. E-STOP pushbutton not operated):
 - The "START" LED is lit.
 - The LEDs "CH.1", "CH.1 [t]", "CH.2" and "CH.2 [t]" are lit.
 - Safety contacts 13-14, 23-24, 33-34, 57-58 and 67-68 are closed, auxiliary contact 41-42 is opened. The unit is active.
 - The "START" LED goes out.
- ▶ Input circuit is opened (e.g. E-STOP pushbutton operated):
 - The LEDs "CH.1" and "CH.2" go out.
 - Safety contacts 13-14, 23-24 and 33-34 are opened redundantly, auxiliary contact 41-42 is closed.
 - Safety contacts 57-58 and 67-68 open after the delay time has elapsed.
 - The LEDs "CH.1 [t]" and "CH.2 [t]" go out.

Before the unit can be restarted, the delay time must have elapsed and the unit must again be ready for operation.

Set delay time:

On units with selectable delay time, the delay time of the safety contacts 57-58 and 67-68 can be set on the front of the unit using a screwdriver.

Reset function:

The delay time cycle can be ended prematurely by opening the reset circuit Y39-Y40. For this purpose, one N/C contact is connected between Y39-Y40 instead of a link.

Operating modes

- ▶ Single-channel operation: No redundancy in the input circuit, earth faults in the start and input circuit are detected.
- ▶ Dual-channel operation with detection of shorts across contacts: Redundant input circuit, detects PNOZ XV3.1P
 - earth faults in the start and input circuit,
 - short circuits in the input circuit,
 - Shorts across contacts in the input circuit.
- ▶ Dual-channel operation without detection of shorts across contacts: Redundant input circuit, detects PNOZ XV3.1P
 - earth faults in the start and input circuit,
 - short circuits in the input circuit.

Safety relays PNOZ X PNOZ XV3.1P

- ▶ Automatic start: Unit is active once the input circuit has been closed.
- ▶ Monitored start: Unit is active once the input circuit is closed and once the start circuit is closed after the waiting period has elapsed (see [Technical details \[380\]](#)).
- ▶ Increase in the number of available contacts by connecting contact expander modules or external contactors/relays.

Timing diagram

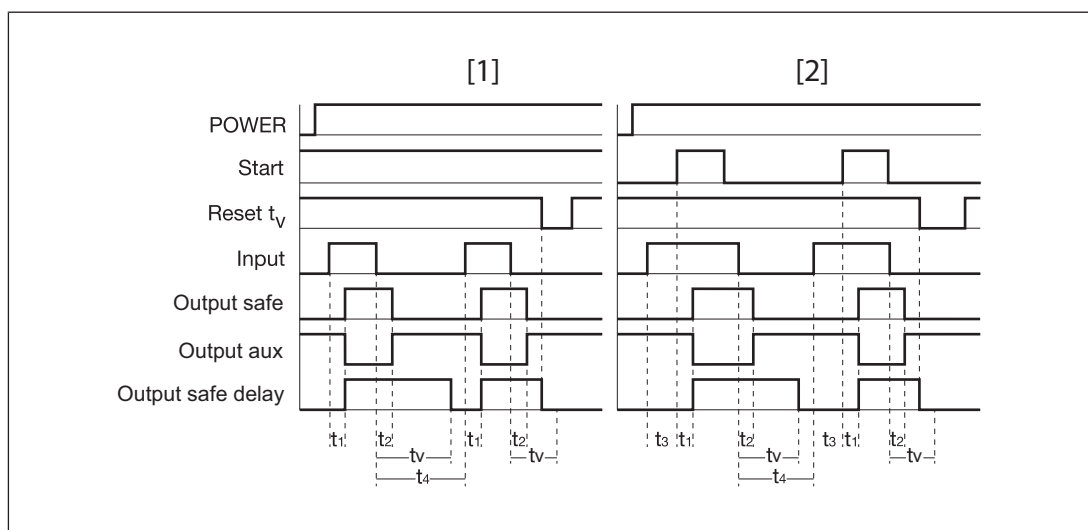

Legend

- ▶ Power: Supply voltage
- ▶ Start: Start circuit
- ▶ Reset t_v : Reset circuit
- ▶ Input: Input circuit
- ▶ Output safe: Safety contacts, instantaneous
- ▶ Output safe delay: Safety contacts, delayed
- ▶ Output aux: Auxiliary contact
- ▶ [1]: Automatic start
- ▶ [2]: Monitored start
- ▶ t_1 : Switch-on delay
- ▶ t_2 : Delay-on de-energisation
- ▶ t_3 : Waiting period with a monitored start
- ▶ t_4 : Recovery time
- ▶ t_v : Delay time

Safety relays PNOZ X PNOZ XV3.1P

Installation

- ▶ The unit should be installed in a control cabinet with a protection type of at least IP54.
- ▶ Use the notch on the rear of the unit to attach it to a DIN rail.
- ▶ Ensure the unit is mounted securely on a vertical DIN rail (35 mm) by using a fixing element (e.g. retaining bracket or an end angle).

Wiring

Please note:

- ▶ Information given in the "[Technical details \[380\]](#)" must be followed.
- ▶ Delivery status of units with screw terminals: Link between S11-S12 (dual-channel input circuit) and link between Y39-Y40 (reset circuit)
- ▶ Outputs 13-14, 23-24, 33-34 are instantaneous safety contacts, outputs 57-58, 67-68 are delay-on de-energisation safety contacts, output 41-42 is an instantaneous auxiliary contact (e.g. for display).
- ▶ Auxiliary contact 41-42 should **not** be used for safety circuits!
- ▶ Do not connect undesignated terminals.
- ▶ To prevent contact welding, a fuse should be connected before the output contacts (see [Technical details \[380\]](#)).
- ▶ Calculation of the max. cable length l_{\max} in the input circuit:

$$l_{\max} = \frac{R_{l_{\max}}}{R_l / \text{km}}$$

$R_{l_{\max}}$ = max. overall cable resistance (see [Technical details \[380\]](#))

R_l / km = cable resistance/km

- ▶ Use copper wire that can withstand 60/75 °C.
- ▶ Sufficient fuse protection must be provided on all output contacts with capacitive and inductive loads.
- ▶ On units with U_B 24 – 240 VAC/DC: Connect operational earth terminal to functional earth.
- ▶ Do not switch low currents using contacts that have been used previously with high currents.
- ▶ On 24 VDC devices:
The power supply must comply with the regulations for extra low voltages with protective electrical separation (SELV, PELV) in accordance with VDE 0100, Part 410.
- ▶ Ensure the wiring and EMC requirements of IEC 60204-1 are met.

Safety relays PNOZ X PNOZ XV3.1P

Important for detection of shorts across contacts:

As this function for detecting shorts across contacts is not failsafe, it is tested by Pilz during the final control check. If there is a danger of exceeding the cable length, we recommend the following test once the unit is installed:

1. Unit ready for operation (output contacts closed)
2. Short circuit the test terminals S22, S32 for detecting shorts across the inputs.
3. The unit's fuse must be triggered and the output contacts must open. Cable lengths in the scale of the maximum length can delay the fuse triggering for up to 2 minutes.
4. Reset the fuse: Remove the short circuit and switch off the supply voltage for approx. 1 minute.

Preparing for operation

| Supply voltage | U _B 24 - 240 VAC/DC | U _B 24 VDC |
|---|--------------------------------|-----------------------|
| | | |
| Input circuit | Single-channel | Dual-channel |
| E-STOP without detection of shorts across contacts | | |
| E-STOP with detection of shorts across contacts | / | |
| Safety gate without detection of shorts across contacts | | |

Safety relays PNOZ X PNOZ XV3.1P

| Input circuit | Single-channel | Dual-channel |
|--|----------------|--------------|
| Safety gate with detection of shorts across contacts | | |
| Light guards or safety switch, detection of shorts across contacts via ESPE (only when $U_B = 24\text{ VDC}$) | | |

| Start circuit | E-STOP wiring Safety gate without start-up test | Safety gate with start-up test |
|-----------------|--|--------------------------------|
| Automatic start | | |
| Monitored start | | |

| Reset delay time | Without reset | With reset |
|---------------------|---------------|------------|
| Link or N/C contact | | |

Safety relays PNOZ X PNOZ XV3.1P

| Feedback loop | Automatic start | Monitored start |
|-----------------------------------|-----------------|-----------------|
| Contacts from external contactors | | |

Legend

- ▶ S1/S2: E-STOP/safety gate switch
- ▶ S3: Reset button
- ▶ ↑↑: Switch operated
- ▶ : Gate open
- ▶ : Gate closed

Dimensions in mm

* with spring-loaded terminals

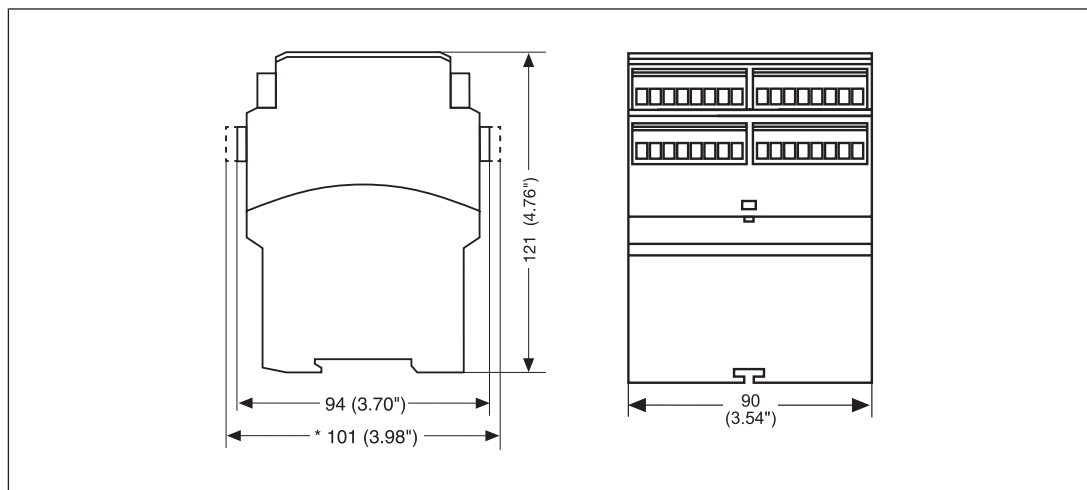

Safety relays PNOZ X PNOZ XV3.1P

Technical details Order no. 777520-777525

| General | 777520 | 777522 | 777525 |
|---|--|--|--|
| Approvals | CCC, CE, EAC (Eurasian), TÜV, cULus Listed | CCC, CE, EAC (Eurasian), TÜV, cULus Listed | CCC, CE, EAC (Eurasian), TÜV, cULus Listed |
| Electrical data | 777520 | 777522 | 777525 |
| Supply voltage | | | |
| Voltage | 24 V | 24 V | 24 V |
| Kind | DC | DC | DC |
| Voltage tolerance | -15 %/+10 % | -15 %/+10 % | -15 %/+10 % |
| Output of external power supply (DC) | 4,5 W | 4,5 W | 4,5 W |
| Residual ripple DC | 160 % | 160 % | 160 % |
| Duty cycle | 100 % | 100 % | 100 % |
| Max. inrush current impulse | | | |
| Current pulse, A1 | 5 A | 5 A | 5 A |
| Pulse duration, A1 | 1 ms | 1 ms | 1 ms |
| Inputs | 777520 | 777522 | 777525 |
| Number | 2 | 2 | 2 |
| Voltage at | | | |
| Input circuit DC | 24 V | 24 V | 24 V |
| Start circuit DC | 24 V | 24 V | 24 V |
| Feedback loop DC | 24 V | 24 V | 24 V |
| Current at | | | |
| Input circuit DC | 50 mA | 50 mA | 50 mA |
| Start circuit DC | 40 mA | 40 mA | 40 mA |
| Feedback loop DC | 3 mA | 3 mA | 3 mA |
| Max. overall cable resistance R _{lmax} | | | |
| Single-channel at UB DC | 100 Ohm | 100 Ohm | 100 Ohm |
| Dual-channel without detection of shorts across contacts at UB DC | 120 Ohm | 120 Ohm | 120 Ohm |
| Dual-channel with detection of shorts across contacts at UB DC | 10 Ohm | 10 Ohm | 10 Ohm |

Safety relays PNOZ X PNOZ XV3.1P

| Relay outputs | 777520 | 777522 | 777525 |
|---|--------------|--------------|--------------|
| Number of output contacts | | | |
| Safety contacts (N/O), instantaneous | 3 | 3 | 3 |
| Safety contacts (N/O), delayed | 2 | 2 | 2 |
| Auxiliary contacts (N/C) | 1 | 1 | 1 |
| Max. short circuit current IK | 1 kA | 1 kA | 1 kA |
| Utilisation category | | | |
| In accordance with the standard | EN 60947-4-1 | EN 60947-4-1 | EN 60947-4-1 |
| Utilisation category of safety contacts | | | |
| AC1 at | 240 V | 240 V | 240 V |
| Min. current | 0,01 A | 0,01 A | 0,01 A |
| Max. current | 8 A | 8 A | 8 A |
| Max. power | 2000 VA | 2000 VA | 2000 VA |
| DC1 at | 24 V | 24 V | 24 V |
| Min. current | 0,01 A | 0,01 A | 0,01 A |
| Max. current | 8 A | 8 A | 8 A |
| Max. power | 200 W | 200 W | 200 W |
| Utilisation category of safety contacts delayed | | | |
| AC1 at | 240 V | 240 V | 240 V |
| Min. current | 0,01 A | 0,01 A | 0,01 A |
| Max. current | 8 A | 8 A | 8 A |
| Max. power | 2000 VA | 2000 VA | 2000 VA |
| DC1 at | 24 V | 24 V | 24 V |
| Min. current | 0,01 A | 0,01 A | 0,01 A |
| Max. current | 8 A | 8 A | 8 A |
| Max. power | 200 W | 200 W | 200 W |
| Utilisation category of auxiliary contacts | | | |
| AC1 at | 240 V | 240 V | 240 V |
| Min. current | 0,01 A | 0,01 A | 0,01 A |
| Max. current | 8 A | 8 A | 8 A |
| Max. power | 2000 VA | 2000 VA | 2000 VA |
| DC1 at | 24 V | 24 V | 24 V |
| Min. current | 0,01 A | 0,01 A | 0,01 A |
| Max. current | 8 A | 8 A | 8 A |
| Max. power | 200 W | 200 W | 200 W |

Safety relays PNOZ X PNOZ XV3.1P

| Relay outputs | 777520 | 777522 | 777525 |
|---|----------------------|----------------------|----------------------|
| Utilisation category | | | |
| In accordance with the standard | EN 60947-5-1 | EN 60947-5-1 | EN 60947-5-1 |
| Utilisation category of safety contacts | | | |
| AC15 at | 230 V | 230 V | 230 V |
| Max. current | 5 A | 5 A | 5 A |
| DC13 (6 cycles/min) at | 24 V | 24 V | 24 V |
| Max. current | 7 A | 7 A | 7 A |
| Utilisation category of safety contacts delayed | | | |
| AC15 at | 230 V | 230 V | 230 V |
| Max. current | 5 A | 5 A | 5 A |
| DC13 (6 cycles/min) at | 24 V | 24 V | 24 V |
| Max. current | 7 A | 7 A | 7 A |
| Utilisation category of auxiliary contacts | | | |
| AC15 at | 230 V | 230 V | 230 V |
| Max. current | 5 A | 5 A | 5 A |
| DC13 (6 cycles/min) at | 24 V | 24 V | 24 V |
| Max. current | 7 A | 7 A | 7 A |
| Utilisation category in accordance with UL | | | |
| Voltage | 240 V AC G. P. | 240 V AC G. P. | 240 V AC G. P. |
| With current | 8 A | 8 A | 8 A |
| Voltage | 24 V DC Resistive | 24 V DC Resistive | 24 V DC Resistive |
| With current | 5 A | 5 A | 5 A |
| Pilot Duty | C300, R300 | C300, R300 | C300, R300 |
| External contact fuse protection, safety contacts | | | |
| In accordance with the standard | EN 60947-5-1 | EN 60947-5-1 | EN 60947-5-1 |
| Max. melting integral | 240 A ² s | 240 A ² s | 240 A ² s |
| Blow-out fuse, quick | 10 A | 10 A | 10 A |
| Blow-out fuse, slow | 6 A | 6 A | 6 A |
| Blow-out fuse, gG | 10 A | 10 A | 10 A |
| Circuit breaker 24V AC/DC, characteristic B/C | 6 A | 6 A | 6 A |

Safety relays PNOZ X PNOZ XV3.1P

| Relay outputs | 777520 | 777522 | 777525 |
|--|--------------------------------------|--------------------------------------|--------------------------------------|
| External contact fuse protection, delayed safety contacts | | | |
| Max. melting integral | 240 A²s | 240 A²s | 240 A²s |
| Blow-out fuse, quick | 10 A | 10 A | 10 A |
| Blow-out fuse, slow | 6 A | 6 A | 6 A |
| Blow-out fuse, gG | 10 A | 10 A | 10 A |
| Circuit breaker 24 V AC/DC, characteristic B/C | 6 A | 6 A | 6 A |
| External contact fuse protection, auxiliary contacts | | | |
| Max. melting integral | 240 A²s | 240 A²s | 240 A²s |
| Blow-out fuse, quick | 10 A | 10 A | 10 A |
| Blow-out fuse, slow | 6 A | 6 A | 6 A |
| Blow-out fuse, gG | 10 A | 10 A | 10 A |
| Circuit breaker 24 V AC/DC, characteristic B/C | 6 A | 6 A | 6 A |
| Contact material | AgSnO₂ + 0,2 µm Au | AgSnO₂ + 0,2 µm Au | AgSnO₂ + 0,2 µm Au |
| Conventional thermal current while loading several contacts | 777520 | 777522 | 777525 |
| I _{th} per contact at UB DC; AC1: 240 V, DC1: 24 V | | | |
| Conv. therm. current with 1 contact | 8 A | 8 A | 8 A |
| Conv. therm. current with 2 contacts | 7,8 A | 7,8 A | 7,8 A |
| Conv. therm. current with 3 contacts | 6,5 A | 6,5 A | 6,5 A |
| Conv. therm. current with 4 contacts | 5,5 A | 5,5 A | 5,5 A |
| Conv. therm. current with 5 contacts | 5 A | 5 A | 5 A |

Safety relays PNOZ X PNOZ XV3.1P

| Times | 777520 | 777522 | 777525 |
|--|---|--|---------------------|
| Switch-on delay | | | |
| With automatic start typ. | 400 ms | 400 ms | 400 ms |
| With automatic start max. | 850 ms | 850 ms | 850 ms |
| With automatic start after power on typ. | 400 ms | 400 ms | 400 ms |
| With automatic start after power on max. | 870 ms | 870 ms | 870 ms |
| With monitored start typ. | 40 ms | 40 ms | 40 ms |
| With monitored start max. | 70 ms | 70 ms | 70 ms |
| Delay-on de-energisation | | | |
| With E-STOP typ. | 15 ms | 15 ms | 15 ms |
| With E-STOP max. | 30 ms | 30 ms | 30 ms |
| With power failure typ. | 110 ms | 110 ms | 110 ms |
| With power failure max. | 150 ms | 150 ms | 150 ms |
| Recovery time at max. switching frequency 1/s | | | |
| After E-STOP | 50 ms +tv | 50 ms +tv | 50 ms +tv |
| After power failure | 200 ms | 200 ms | 200 ms |
| Delay time tv | 0,1 s, 0,5 s, 1 s, 2 s, 4 s, 6 s, 8 s, 10 s, 15 s, 20 s, 25 s, 30 s | 0,1 s, 0,2 s, 0,3 s, 0,4 s, 0,5 s, 0,6 s, 0,7 s, 0,8 s, 1 s, 1,5 s, 2 s, 3 s | 3 s |
| Time accuracy | -15 %/+15 % +50 ms | -15 %/+15 % +50 ms | -15 %/+15 % +50 ms |
| Repetition accuracy | 2 % | 2 % | 2 % |
| Waiting period with a monitored start | 300 ms | 300 ms | 300 ms |
| Min. start pulse duration with a monitored start | 30 ms | 30 ms | 30 ms |
| Supply interruption before de-energisation | 20 ms | 20 ms | 20 ms |
| Simultaneity, channel 1 and 2 max. | ∞ | ∞ | ∞ |
| Environmental data | 777520 | 777522 | 777525 |
| Climatic suitability | EN 60068-2-78 | EN 60068-2-78 | EN 60068-2-78 |
| Ambient temperature | | | |
| Temperature range | -10 - 55 °C | -10 - 55 °C | -10 - 55 °C |
| Storage temperature | | | |
| Temperature range | -40 - 85 °C | -40 - 85 °C | -40 - 85 °C |
| Climatic suitability | | | |
| Humidity | 93 % r. h. at 40 °C | 93 % r. h. at 40 °C | 93 % r. h. at 40 °C |

Safety relays PNOZ X PNOZ XV3.1P

| Environmental data | 777520 | 777522 | 777525 |
|---|--|--|--|
| Condensation during operation | Not permitted | Not permitted | Not permitted |
| EMC | EN 60947-5-1, EN 61000-6-2, EN 61326-3-1 | EN 60947-5-1, EN 61000-6-2, EN 61326-3-1 | EN 60947-5-1, EN 61000-6-2, EN 61326-3-1 |
| Vibration | | | |
| In accordance with the standard | EN 60068-2-6 | EN 60068-2-6 | EN 60068-2-6 |
| Frequency | 10 - 55 Hz | 10 - 55 Hz | 10 - 55 Hz |
| Amplitude | 0,35 mm | 0,35 mm | 0,35 mm |
| Airgap creepage | | | |
| In accordance with the standard | EN 60947-1 | EN 60947-1 | EN 60947-1 |
| Overvoltage category | III / II | III / II | III / II |
| Pollution degree | 2 | 2 | 2 |
| Rated insulation voltage | 250 V | 250 V | 250 V |
| Rated impulse withstand voltage | 4 kV | 4 kV | 4 kV |
| Protection type | | | |
| Mounting area (e.g. control cabinet) | IP54 | IP54 | IP54 |
| Housing | IP40 | IP40 | IP40 |
| Terminals | IP20 | IP20 | IP20 |
| Mechanical data | 777520 | 777522 | 777525 |
| Mounting position | Any | Any | Any |
| Mechanical life | 10,000,000 cycles | 10,000,000 cycles | 10,000,000 cycles |
| Material | | | |
| Bottom | PPO UL 94 V0 | PPO UL 94 V0 | PPO UL 94 V0 |
| Front | ABS UL 94 V0 | ABS UL 94 V0 | ABS UL 94 V0 |
| Top | PPO UL 94 V0 | PPO UL 94 V0 | PPO UL 94 V0 |
| Connection type | Screw terminal | Screw terminal | Screw terminal |
| Mounting type | plug-in | plug-in | plug-in |
| Conductor cross section with screw terminals | | | |
| 1 core flexible | 0,25 - 2,5 mm ² , 24 - 12 AWG | 0,25 - 2,5 mm ² , 24 - 12 AWG | 0,25 - 2,5 mm ² , 24 - 12 AWG |
| 2 core with the same cross section, flexible with crimp connectors, no plastic sleeve | 0,25 - 1 mm ² , 24 - 16 AWG | 0,25 - 1 mm ² , 24 - 16 AWG | 0,25 - 1 mm ² , 24 - 16 AWG |
| 2 core with the same cross section, flexible without crimp connectors or with TWIN crimp connectors | 0,2 - 1,5 mm ² , 24 - 16 AWG | 0,2 - 1,5 mm ² , 24 - 16 AWG | 0,2 - 1,5 mm ² , 24 - 16 AWG |

Safety relays PNOZ X PNOZ XV3.1P

| Mechanical data | 777520 | 777522 | 777525 |
|-------------------------------------|--------|--------|--------|
| Torque setting with screw terminals | 0,5 Nm | 0,5 Nm | 0,5 Nm |
| Dimensions | | | |
| Height | 94 mm | 94 mm | 94 mm |
| Width | 90 mm | 90 mm | 90 mm |
| Depth | 121 mm | 121 mm | 121 mm |
| Weight | 510 g | 510 g | 500 g |

Where standards are undated, the 2014-07 latest editions shall apply.

Technical details Order no. 777530-777538

| General | 777530 | 777532 | 777538 |
|--------------------------------------|--|--|--|
| Approvals | CCC, CE, EAC (Eurasian), TÜV, cULus Listed | CCC, CE, EAC (Eurasian), TÜV, cULus Listed | CCC, CE, EAC (Eurasian), TÜV, cULus Listed |
| Electrical data | 777530 | 777532 | 777538 |
| Supply voltage | | | |
| Voltage | 24 - 240 V | 24 - 240 V | 24 - 240 V |
| Kind | AC/DC | AC/DC | AC/DC |
| Voltage tolerance | -15 %/+10 % | -15 %/+10 % | -15 %/+10 % |
| Output of external power supply (AC) | 8,5 VA | 8,5 VA | 8,5 VA |
| Output of external power supply (DC) | 5 W | 5 W | 5 W |
| Frequency range AC | 50 - 60 Hz | 50 - 60 Hz | 50 - 60 Hz |
| Residual ripple DC | 160 % | 160 % | 160 % |
| Duty cycle | 100 % | 100 % | 100 % |
| Inputs | 777530 | 777532 | 777538 |
| Number | 2 | 2 | 2 |
| Voltage at | | | |
| Input circuit DC | 24 V | 24 V | 24 V |
| Start circuit DC | 24 V | 24 V | 24 V |
| Feedback loop DC | 24 V | 24 V | 24 V |
| Current at | | | |
| Input circuit DC | 40 mA | 40 mA | 40 mA |
| Start circuit DC | 40 mA | 40 mA | 40 mA |
| Feedback loop DC | 3 mA | 3 mA | 3 mA |

Safety relays PNOZ X PNOZ XV3.1P

| Inputs | 777530 | 777532 | 777538 |
|---|--------------|--------------|--------------|
| Max. overall cable resistance R _{lmax} | | | |
| Single-channel at UB DC | 150 Ohm | 150 Ohm | 150 Ohm |
| Single-channel at UB AC | 150 Ohm | 150 Ohm | 150 Ohm |
| Dual-channel without detection of shorts across contacts at UB DC | 200 Ohm | 200 Ohm | 200 Ohm |
| Dual-channel without detection of shorts across contacts at UB AC | 200 Ohm | 200 Ohm | 200 Ohm |
| Dual-channel with detection of shorts across contacts at UB DC | 20 Ohm | 20 Ohm | 20 Ohm |
| Dual-channel with detection of shorts across contacts at UB AC | 20 Ohm | 20 Ohm | 20 Ohm |
| Relay outputs | 777530 | 777532 | 777538 |
| Number of output contacts | | | |
| Safety contacts (N/O), instantaneous | 3 | 3 | 3 |
| Safety contacts (N/O), delayed | 2 | 2 | 2 |
| Auxiliary contacts (N/C) | 1 | 1 | 1 |
| Max. short circuit current I _K | 1 kA | 1 kA | 1 kA |
| Utilisation category | | | |
| In accordance with the standard | EN 60947-4-1 | EN 60947-4-1 | EN 60947-4-1 |
| Utilisation category of safety contacts | | | |
| AC1 at | 240 V | 240 V | 240 V |
| Min. current | 0,01 A | 0,01 A | 0,01 A |
| Max. current | 8 A | 8 A | 8 A |
| Max. power | 2000 VA | 2000 VA | 2000 VA |
| DC1 at | 24 V | 24 V | 24 V |
| Min. current | 0,01 A | 0,01 A | 0,01 A |
| Max. current | 8 A | 8 A | 8 A |
| Max. power | 200 W | 200 W | 200 W |

Safety relays PNOZ X PNOZ XV3.1P

| Relay outputs | 777530 | 777532 | 777538 |
|---|---------------------|---------------------|---------------------|
| Utilisation category of safety contacts delayed | | | |
| AC1 at | 240 V | 240 V | 240 V |
| Min. current | 0,01 A | 0,01 A | 0,01 A |
| Max. current | 8 A | 8 A | 8 A |
| Max. power | 2000 VA | 2000 VA | 2000 VA |
| DC1 at | 24 V | 24 V | 24 V |
| Min. current | 0,01 A | 0,01 A | 0,01 A |
| Max. current | 8 A | 8 A | 8 A |
| Max. power | 200 W | 200 W | 200 W |
| Utilisation category of auxiliary contacts | | | |
| AC1 at | 240 V | 240 V | 240 V |
| Min. current | 0,01 A | 0,01 A | 0,01 A |
| Max. current | 8 A | 8 A | 8 A |
| Max. power | 2000 VA | 2000 VA | 2000 VA |
| DC1 at | 24 V | 24 V | 24 V |
| Min. current | 0,01 A | 0,01 A | 0,01 A |
| Max. current | 8 A | 8 A | 8 A |
| Max. power | 200 W | 200 W | 200 W |
| Utilisation category In accordance with the standard | | | |
| | EN 60947-5-1 | EN 60947-5-1 | EN 60947-5-1 |
| Utilisation category of safety contacts | | | |
| AC15 at | 230 V | 230 V | 230 V |
| Max. current | 5 A | 5 A | 5 A |
| DC13 (6 cycles/min) at | 24 V | 24 V | 24 V |
| Max. current | 7 A | 7 A | 7 A |
| Utilisation category of safety contacts delayed | | | |
| AC15 at | 230 V | 230 V | 230 V |
| Max. current | 5 A | 5 A | 5 A |
| DC13 (6 cycles/min) at | 24 V | 24 V | 24 V |
| Max. current | 7 A | 7 A | 7 A |
| Utilisation category of auxiliary contacts | | | |
| AC15 at | 230 V | 230 V | 230 V |
| Max. current | 5 A | 5 A | 5 A |
| DC13 (6 cycles/min) at | 24 V | 24 V | 24 V |
| Max. current | 7 A | 7 A | 7 A |

Safety relays PNOZ X PNOZ XV3.1P

| Relay outputs | 777530 | 777532 | 777538 |
|---|--------------------------------------|--------------------------------------|--------------------------------------|
| Utilisation category in accordance with UL | | | |
| Voltage | 240 V AC G. P. | 240 V AC G. P. | 240 V AC G. P. |
| With current | 8 A | 8 A | 8 A |
| Voltage | 24 V DC Resistive | 24 V DC Resistive | 24 V DC Resistive |
| With current | 5 A | 5 A | 5 A |
| Pilot Duty | C300, R300 | C300, R300 | C300, R300 |
| External contact fuse protection, safety contacts | | | |
| In accordance with the standard | EN 60947-5-1 | EN 60947-5-1 | EN 60947-5-1 |
| Max. melting integral | 240 A²s | 240 A²s | 240 A²s |
| Blow-out fuse, quick | 10 A | 10 A | 10 A |
| Blow-out fuse, slow | 6 A | 6 A | 6 A |
| Blow-out fuse, gG | 10 A | 10 A | 10 A |
| Circuit breaker 24V AC/DC, characteristic B/C | 6 A | 6 A | 6 A |
| External contact fuse protection, delayed safety contacts | | | |
| Max. melting integral | 240 A²s | 240 A²s | 240 A²s |
| Blow-out fuse, quick | 10 A | 10 A | 10 A |
| Blow-out fuse, slow | 6 A | 6 A | 6 A |
| Blow-out fuse, gG | 10 A | 10 A | 10 A |
| Circuit breaker 24 V AC/DC, characteristic B/C | 6 A | 6 A | 6 A |
| External contact fuse protection, auxiliary contacts | | | |
| Max. melting integral | 240 A²s | 240 A²s | 240 A²s |
| Blow-out fuse, quick | 10 A | 10 A | 10 A |
| Blow-out fuse, slow | 6 A | 6 A | 6 A |
| Blow-out fuse, gG | 10 A | 10 A | 10 A |
| Circuit breaker 24 V AC/DC, characteristic B/C | 6 A | 6 A | 6 A |
| Contact material | AgSnO₂ + 0,2 µm Au | AgSnO₂ + 0,2 µm Au | AgSnO₂ + 0,2 µm Au |

Safety relays PNOZ X PNOZ XV3.1P

| Conventional thermal current while loading several contacts | 777530 | 777532 | 777538 |
|--|-----------------|-----------------|-----------------|
| Ith per contact at UB AC; AC1: 240 V, DC1: 24 V | | | |
| Conv. therm. current with 1 contact | 8 A | 8 A | 8 A |
| Conv. therm. current with 2 contacts | 7,8 A | 7,8 A | 7,8 A |
| Conv. therm. current with 3 contacts | 6,5 A | 6,5 A | 6,5 A |
| Conv. therm. current with 4 contacts | 5,5 A | 5,5 A | 5,5 A |
| Conv. therm. current with 5 contacts | 5 A | 5 A | 5 A |
| Ith per contact at UB DC; AC1: 240 V, DC1: 24 V | | | |
| Conv. therm. current with 1 contact | 8 A | 8 A | 8 A |
| Conv. therm. current with 2 contacts | 7,8 A | 7,8 A | 7,8 A |
| Conv. therm. current with 3 contacts | 6,5 A | 6,5 A | 6,5 A |
| Conv. therm. current with 4 contacts | 5,5 A | 5,5 A | 5,5 A |
| Conv. therm. current with 5 contacts | 5 A | 5 A | 5 A |
| Times | 777530 | 777532 | 777538 |
| Switch-on delay | | | |
| With automatic start typ. | 400 ms | 400 ms | 400 ms |
| With automatic start max. | 550 ms | 550 ms | 550 ms |
| With automatic start after power on typ. | 750 ms | 750 ms | 750 ms |
| With automatic start after power on max. | 1.050 ms | 1.050 ms | 1.050 ms |
| With monitored start typ. | 35 ms | 35 ms | 35 ms |
| With monitored start max. | 60 ms | 60 ms | 60 ms |

Safety relays PNOZ X PNOZ XV3.1P

| Times | 777530 | 777532 | 777538 |
|--|---|--|---|
| Delay-on de-energisation | | | |
| With E-STOP typ. | 15 ms | 15 ms | 15 ms |
| With E-STOP max. | 30 ms | 30 ms | 30 ms |
| With power failure typ. UB 240 V | 900 ms | 900 ms | 900 ms |
| With power failure max. UB 240 V | 1400 ms | 1400 ms | 1400 ms |
| With power failure typ. UB 24 V | 120 ms | 120 ms | 120 ms |
| With power failure max. UB 24 V | 170 ms | 170 ms | 170 ms |
| Recovery time at max. switching frequency 1/s | | | |
| After E-STOP | 50 ms +tv | 50 ms +tv | 50 ms +tv |
| After power failure on wide-range power supply | 1450 ms | 1450 ms | 1450 ms |
| Delay time tv | 0,1 s, 0,5 s, 1 s, 2 s, 4 s, 6 s, 8 s, 10 s, 15 s, 20 s, 25 s, 30 s | 0,1 s, 0,2 s, 0,3 s, 0,4 s, 0,5 s, 0,6 s, 0,7 s, 0,8 s, 1 s, 1,5 s, 2 s, 3 s | 0,3 s, 5 s, 10 s, 20 s, 40 s, 60 s, 80 s, 100 s, 150 s, 200 s, 250 s, 300 s |
| Time accuracy | -15 %/+15 % +50 ms | -15 %/+15 % +50 ms | -15 %/+15 % +50 ms |
| Repetition accuracy | 2 % | 2 % | 2 % |
| Waiting period with a monitored start | 300 ms | 300 ms | 300 ms |
| Min. start pulse duration with a monitored start | 30 ms | 30 ms | 30 ms |
| Supply interruption before de-energisation | 20 ms | 20 ms | 20 ms |
| Simultaneity, channel 1 and 2 max. | ∞ | ∞ | ∞ |
| Environmental data | 777530 | 777532 | 777538 |
| Climatic suitability | EN 60068-2-78 | EN 60068-2-78 | EN 60068-2-78 |
| Ambient temperature | | | |
| Temperature range | -10 - 55 °C | -10 - 55 °C | -10 - 55 °C |
| Storage temperature | | | |
| Temperature range | -40 - 85 °C | -40 - 85 °C | -40 - 85 °C |
| Climatic suitability | | | |
| Humidity | 93 % r. h. at 40 °C | 93 % r. h. at 40 °C | 93 % r. h. at 40 °C |
| Condensation during operation | Not permitted | Not permitted | Not permitted |
| EMC | EN 60947-5-1, EN 61000-6-2, EN 61000-6-4, EN 61326-3-1 | EN 60947-5-1, EN 61000-6-2, EN 61000-6-4, EN 61326-3-1 | EN 60947-5-1, EN 61000-6-2, EN 61000-6-4, EN 61326-3-1 |

Safety relays PNOZ X PNOZ XV3.1P

| Environmental data | 777530 | 777532 | 777538 |
|---|--|--|--|
| Vibration | | | |
| In accordance with the standard | EN 60068-2-6 | EN 60068-2-6 | EN 60068-2-6 |
| Frequency | 10 - 55 Hz | 10 - 55 Hz | 10 - 55 Hz |
| Amplitude | 0,35 mm | 0,35 mm | 0,35 mm |
| Airgap creepage | | | |
| In accordance with the standard | EN 60947-1 | EN 60947-1 | EN 60947-1 |
| Overvoltage category | III / II | III / II | III / II |
| Pollution degree | 2 | 2 | 2 |
| Rated insulation voltage | 250 V | 250 V | 250 V |
| Rated impulse withstand voltage | 4 kV | 4 kV | 4 kV |
| Protection type | | | |
| Mounting area (e.g. control cabinet) | IP54 | IP54 | IP54 |
| Housing | IP40 | IP40 | IP40 |
| Terminals | IP20 | IP20 | IP20 |
| Mechanical data | 777530 | 777532 | 777538 |
| Mounting position | Any | Any | Any |
| Mechanical life | 10,000,000 cycles | 10,000,000 cycles | 10,000,000 cycles |
| Material | | | |
| Bottom | PPO UL 94 V0 | PPO UL 94 V0 | PPO UL 94 V0 |
| Front | ABS UL 94 V0 | ABS UL 94 V0 | ABS UL 94 V0 |
| Top | PPO UL 94 V0 | PPO UL 94 V0 | PPO UL 94 V0 |
| Connection type | Screw terminal | Screw terminal | Screw terminal |
| Mounting type | plug-in | plug-in | plug-in |
| Conductor cross section with screw terminals | | | |
| 1 core flexible | 0,25 - 2,5 mm ² , 24 - 12 AWG | 0,25 - 2,5 mm ² , 24 - 12 AWG | 0,25 - 2,5 mm ² , 24 - 12 AWG |
| 2 core with the same cross section, flexible with crimp connectors, no plastic sleeve | 0,25 - 1 mm ² , 24 - 16 AWG | 0,25 - 1 mm ² , 24 - 16 AWG | 0,25 - 1 mm ² , 24 - 16 AWG |
| 2 core with the same cross section, flexible without crimp connectors or with TWIN crimp connectors | 0,2 - 1,5 mm ² , 24 - 16 AWG | 0,2 - 1,5 mm ² , 24 - 16 AWG | 0,2 - 1,5 mm ² , 24 - 16 AWG |
| Torque setting with screw terminals | 0,5 Nm | 0,5 Nm | 0,5 Nm |

Safety relays PNOZ X PNOZ XV3.1P

| Mechanical data | 777530 | 777532 | 777538 |
|-----------------|--------|--------|--------|
| Dimensions | | | |
| Height | 94 mm | 94 mm | 94 mm |
| Width | 90 mm | 90 mm | 90 mm |
| Depth | 121 mm | 121 mm | 121 mm |
| Weight | 540 g | 540 g | 540 g |

Where standards are undated, the 2014-07 latest editions shall apply.

Technical details Order no. 787520-787530

| General | 787520 | 787522 | 787530 |
|--------------------------------------|--|--|--|
| Approvals | CCC, CE, EAC (Eurasian), TÜV, cULus Listed | CCC, CE, EAC (Eurasian), TÜV, cULus Listed | CCC, CE, EAC (Eurasian), TÜV, cULus Listed |
| Electrical data | 787520 | 787522 | 787530 |
| Supply voltage | | | |
| Voltage | 24 V | 24 V | 24 - 240 V |
| Kind | DC | DC | AC/DC |
| Voltage tolerance | -15 %/+10 % | -15 %/+10 % | -15 %/+10 % |
| Output of external power supply (AC) | – | – | 8,5 VA |
| Output of external power supply (DC) | 4,5 W | 4,5 W | 5 W |
| Frequency range AC | – | – | 50 - 60 Hz |
| Residual ripple DC | 160 % | 160 % | 160 % |
| Duty cycle | 100 % | 100 % | 100 % |
| Max. inrush current impulse | | | |
| Current pulse, A1 | 5 A | 5 A | – |
| Pulse duration, A1 | 1 ms | 1 ms | – |
| Inputs | 787520 | 787522 | 787530 |
| Number | 2 | 2 | 2 |
| Voltage at | | | |
| Input circuit DC | 24 V | 24 V | 24 V |
| Start circuit DC | 24 V | 24 V | 24 V |
| Feedback loop DC | 24 V | 24 V | 24 V |
| Current at | | | |
| Input circuit DC | 50 mA | 50 mA | 40 mA |
| Start circuit DC | 40 mA | 40 mA | 40 mA |
| Feedback loop DC | 3 mA | 3 mA | 3 mA |

Safety relays PNOZ X PNOZ XV3.1P

| Inputs | 787520 | 787522 | 787530 |
|---|--------------|--------------|--------------|
| Max. overall cable resistance R _{lmax} | | | |
| Single-channel at UB DC | 100 Ohm | 100 Ohm | 150 Ohm |
| Single-channel at UB AC | – | – | 150 Ohm |
| Dual-channel without detection of shorts across contacts at UB DC | 120 Ohm | 120 Ohm | 200 Ohm |
| Dual-channel without detection of shorts across contacts at UB AC | – | – | 200 Ohm |
| Dual-channel with detection of shorts across contacts at UB DC | 10 Ohm | 10 Ohm | 20 Ohm |
| Dual-channel with detection of shorts across contacts at UB AC | – | – | 20 Ohm |
| Relay outputs | 787520 | 787522 | 787530 |
| Number of output contacts | | | |
| Safety contacts (N/O), instantaneous | 3 | 3 | 3 |
| Safety contacts (N/O), delayed | 2 | 2 | 2 |
| Auxiliary contacts (N/C) | 1 | 1 | 1 |
| Max. short circuit current I _K | 1 kA | 1 kA | 1 kA |
| Utilisation category | | | |
| In accordance with the standard | EN 60947-4-1 | EN 60947-4-1 | EN 60947-4-1 |
| Utilisation category of safety contacts | | | |
| AC1 at | 240 V | 240 V | 240 V |
| Min. current | 0,01 A | 0,01 A | 0,01 A |
| Max. current | 8 A | 8 A | 8 A |
| Max. power | 2000 VA | 2000 VA | 2000 VA |
| DC1 at | 24 V | 24 V | 24 V |
| Min. current | 0,01 A | 0,01 A | 0,01 A |
| Max. current | 8 A | 8 A | 8 A |
| Max. power | 200 W | 200 W | 200 W |

Safety relays PNOZ X PNOZ XV3.1P

| Relay outputs | 787520 | 787522 | 787530 |
|---|---------------------|---------------------|---------------------|
| Utilisation category of safety contacts delayed | | | |
| AC1 at | 240 V | 240 V | 240 V |
| Min. current | 0,01 A | 0,01 A | 0,01 A |
| Max. current | 8 A | 8 A | 8 A |
| Max. power | 2000 VA | 2000 VA | 2000 VA |
| DC1 at | 24 V | 24 V | 24 V |
| Min. current | 0,01 A | 0,01 A | 0,01 A |
| Max. current | 8 A | 8 A | 8 A |
| Max. power | 200 W | 200 W | 200 W |
| Utilisation category of auxiliary contacts | | | |
| AC1 at | 240 V | 240 V | 240 V |
| Min. current | 0,01 A | 0,01 A | 0,01 A |
| Max. current | 8 A | 8 A | 8 A |
| Max. power | 2000 VA | 2000 VA | 2000 VA |
| DC1 at | 24 V | 24 V | 24 V |
| Min. current | 0,01 A | 0,01 A | 0,01 A |
| Max. current | 8 A | 8 A | 8 A |
| Max. power | 200 W | 200 W | 200 W |
| Utilisation category | | | |
| In accordance with the standard | EN 60947-5-1 | EN 60947-5-1 | EN 60947-5-1 |
| Utilisation category of safety contacts | | | |
| AC15 at | 230 V | 230 V | 230 V |
| Max. current | 5 A | 5 A | 5 A |
| DC13 (6 cycles/min) at | 24 V | 24 V | 24 V |
| Max. current | 7 A | 7 A | 7 A |
| Utilisation category of safety contacts delayed | | | |
| AC15 at | 230 V | 230 V | 230 V |
| Max. current | 5 A | 5 A | 5 A |
| DC13 (6 cycles/min) at | 24 V | 24 V | 24 V |
| Max. current | 7 A | 7 A | 7 A |
| Utilisation category of auxiliary contacts | | | |
| AC15 at | 230 V | 230 V | 230 V |
| Max. current | 5 A | 5 A | 5 A |
| DC13 (6 cycles/min) at | 24 V | 24 V | 24 V |
| Max. current | 7 A | 7 A | 7 A |

Safety relays PNOZ X PNOZ XV3.1P

| Relay outputs | 787520 | 787522 | 787530 |
|---|--------------------------------------|--------------------------------------|--------------------------------------|
| Utilisation category in accordance with UL | | | |
| Voltage | 240 V AC G. P. | 240 V AC G. P. | 240 V AC G. P. |
| With current | 8 A | 8 A | 8 A |
| Voltage | 24 V DC Resistive | 24 V DC Resistive | 24 V DC Resistive |
| With current | 5 A | 5 A | 5 A |
| Pilot Duty | C300, R300 | C300, R300 | C300, R300 |
| External contact fuse protection, safety contacts | | | |
| In accordance with the standard | EN 60947-5-1 | EN 60947-5-1 | EN 60947-5-1 |
| Max. melting integral | 240 A²s | 240 A²s | 240 A²s |
| Blow-out fuse, quick | 10 A | 10 A | 10 A |
| Blow-out fuse, slow | 6 A | 6 A | 6 A |
| Blow-out fuse, gG | 10 A | 10 A | 10 A |
| Circuit breaker 24V AC/DC, characteristic B/C | 6 A | 6 A | 6 A |
| External contact fuse protection, delayed safety contacts | | | |
| Max. melting integral | 240 A²s | 240 A²s | 240 A²s |
| Blow-out fuse, quick | 10 A | 10 A | 10 A |
| Blow-out fuse, slow | 6 A | 6 A | 6 A |
| Blow-out fuse, gG | 10 A | 10 A | 10 A |
| Circuit breaker 24 V AC/DC, characteristic B/C | 6 A | 6 A | 6 A |
| External contact fuse protection, auxiliary contacts | | | |
| Max. melting integral | 240 A²s | 240 A²s | 240 A²s |
| Blow-out fuse, quick | 10 A | 10 A | 10 A |
| Blow-out fuse, slow | 6 A | 6 A | 6 A |
| Blow-out fuse, gG | 10 A | 10 A | 10 A |
| Circuit breaker 24 V AC/DC, characteristic B/C | 6 A | 6 A | 6 A |
| Contact material | AgSnO₂ + 0,2 µm Au | AgSnO₂ + 0,2 µm Au | AgSnO₂ + 0,2 µm Au |

Safety relays PNOZ X PNOZ XV3.1P

| Conventional thermal current while loading several contacts | 787520 | 787522 | 787530 |
|---|---------------|---------------|-----------------|
| Ith per contact at UB AC; AC1: 240 V, DC1: 24 V | | | |
| Conv. therm. current with 1 contact | – | – | 8 A |
| Conv. therm. current with 2 contacts | – | – | 7,8 A |
| Conv. therm. current with 3 contacts | – | – | 6,5 A |
| Conv. therm. current with 4 contacts | – | – | 5,5 A |
| Conv. therm. current with 5 contacts | – | – | 5 A |
| Ith per contact at UB DC; AC1: 240 V, DC1: 24 V | | | |
| Conv. therm. current with 1 contact | 8 A | 8 A | 8 A |
| Conv. therm. current with 2 contacts | 7,8 A | 7,8 A | 7,8 A |
| Conv. therm. current with 3 contacts | 6,5 A | 6,5 A | 6,5 A |
| Conv. therm. current with 4 contacts | 5,5 A | 5,5 A | 5,5 A |
| Conv. therm. current with 5 contacts | 5 A | 5 A | 5 A |
| Times | 787520 | 787522 | 787530 |
| Switch-on delay | | | |
| With automatic start typ. | 400 ms | 400 ms | 400 ms |
| With automatic start max. | 850 ms | 850 ms | 550 ms |
| With automatic start after power on typ. | 400 ms | 400 ms | 750 ms |
| With automatic start after power on max. | 870 ms | 870 ms | 1.050 ms |
| With monitored start typ. | 40 ms | 40 ms | 35 ms |
| With monitored start max. | 70 ms | 70 ms | 60 ms |

Safety relays PNOZ X PNOZ XV3.1P

| Times | 787520 | 787522 | 787530 |
|---|---|--|---|
| Delay-on de-energisation | | | |
| With E-STOP typ. | 15 ms | 15 ms | 15 ms |
| With E-STOP max. | 30 ms | 30 ms | 30 ms |
| With power failure typ. | 110 ms | 110 ms | – |
| With power failure max. | 150 ms | 150 ms | – |
| With power failure typ. UB 240 V | – | – | 900 ms |
| With power failure max. UB 240 V | – | – | 1400 ms |
| With power failure typ. UB 24 V | – | – | 120 ms |
| With power failure max. UB 24 V | – | – | 170 ms |
| Recovery time at max. switching frequency 1/s | | | |
| After E-STOP | 50 ms +tv | 50 ms +tv | 50 ms +tv |
| After power failure | 200 ms | 200 ms | – |
| After power failure on wide-range power supply | – | – | 1450 ms |
| Delay time tv | 0,1 s, 0,5 s, 1 s, 2 s, 4 s, 6 s, 8 s, 10 s, 15 s, 20 s, 25 s, 30 s | 0,1 s, 0,2 s, 0,3 s, 0,4 s, 0,5 s, 0,6 s, 0,7 s, 0,8 s, 1 s, 1,5 s, 2 s, 3 s | 0,1 s, 0,5 s, 1 s, 2 s, 4 s, 6 s, 8 s, 10 s, 15 s, 20 s, 25 s, 30 s |
| Time accuracy | -15 %/+15 % +50 ms | -15 %/+15 % +50 ms | -15 %/+15 % +50 ms |
| Repetition accuracy | 2 % | 2 % | 2 % |
| Waiting period with a monitored start | 300 ms | 300 ms | 300 ms |
| Min. start pulse duration with a monitored start | 30 ms | 30 ms | 30 ms |
| Supply interruption before de-energisation | 20 ms | 20 ms | 20 ms |
| Simultaneity, channel 1 and 2 max. | ∞ | ∞ | ∞ |
| Environmental data | 787520 | 787522 | 787530 |
| Climatic suitability | EN 60068-2-78 | EN 60068-2-78 | EN 60068-2-78 |
| Ambient temperature | | | |
| Temperature range | -10 - 55 °C | -10 - 55 °C | -10 - 55 °C |
| Storage temperature | | | |
| Temperature range | -40 - 85 °C | -40 - 85 °C | -40 - 85 °C |
| Climatic suitability | | | |
| Humidity | 93 % r. h. at 40 °C | 93 % r. h. at 40 °C | 93 % r. h. at 40 °C |
| Condensation during operation | Not permitted | Not permitted | Not permitted |

Safety relays PNOZ X PNOZ XV3.1P

| Environmental data | 787520 | 787522 | 787530 |
|---|--|--|--|
| EMC | EN 60947-5-1, EN 61000-6-2, EN 61326-3-1 | EN 60947-5-1, EN 61000-6-2, EN 61326-3-1 | EN 60947-5-1, EN 61000-6-2, EN 61000-6-4, EN 61326-3-1 |
| Vibration | | | |
| In accordance with the standard | EN 60068-2-6 | EN 60068-2-6 | EN 60068-2-6 |
| Frequency | 10 - 55 Hz | 10 - 55 Hz | 10 - 55 Hz |
| Amplitude | 0,35 mm | 0,35 mm | 0,35 mm |
| Airgap creepage | | | |
| In accordance with the standard | EN 60947-1 | EN 60947-1 | EN 60947-1 |
| Overvoltage category | III / II | III / II | III / II |
| Pollution degree | 2 | 2 | 2 |
| Rated insulation voltage | 250 V | 250 V | 250 V |
| Rated impulse withstand voltage | 4 kV | 4 kV | 4 kV |
| Protection type | | | |
| Mounting area (e.g. control cabinet) | IP54 | IP54 | IP54 |
| Housing | IP40 | IP40 | IP40 |
| Terminals | IP20 | IP20 | IP20 |
| Mechanical data | 787520 | 787522 | 787530 |
| Mounting position | Any | Any | Any |
| Mechanical life | 10,000,000 cycles | 10,000,000 cycles | 10,000,000 cycles |
| Material | | | |
| Bottom | PPO UL 94 V0 | PPO UL 94 V0 | PPO UL 94 V0 |
| Front | ABS UL 94 V0 | ABS UL 94 V0 | ABS UL 94 V0 |
| Top | PPO UL 94 V0 | PPO UL 94 V0 | PPO UL 94 V0 |
| Connection type | Spring-loaded terminal | Spring-loaded terminal | Spring-loaded terminal |
| Mounting type | plug-in | plug-in | plug-in |
| Conductor cross section with spring-loaded terminals: Flexible with/without crimp connector | 0,2 - 1,5 mm ² , 24 - 16 AWG | 0,2 - 1,5 mm ² , 24 - 16 AWG | 0,2 - 1,5 mm ² , 24 - 16 AWG |
| Spring-loaded terminals: Terminal points per connection | 2 | 2 | 2 |
| Stripping length with spring-loaded terminals | 8 mm | 8 mm | 8 mm |
| Dimensions | | | |
| Height | 101 mm | 101 mm | 101 mm |
| Width | 90 mm | 90 mm | 90 mm |
| Depth | 121 mm | 121 mm | 121 mm |

Safety relays PNOZ X PNOZ XV3.1P

| Mechanical data | 787520 | 787522 | 787530 |
|-----------------|--------|--------|--------|
| Weight | 510 g | 510 g | 535 g |

Where standards are undated, the 2014-07 latest editions shall apply.

Technical details Order no. 787532-787538

| General | 787532 | 787538 |
|--------------------------------------|--|--|
| Approvals | CCC, CE, EAC (Eurasian), TÜV, cULus Listed | CCC, CE, EAC (Eurasian), TÜV, cULus Listed |
| Electrical data | 787532 | 787538 |
| Supply voltage | | |
| Voltage | 24 - 240 V | 24 - 240 V |
| Kind | AC/DC | AC/DC |
| Voltage tolerance | -15 %/+10 % | -15 %/+10 % |
| Output of external power supply (AC) | 8,5 VA | 8,5 VA |
| Output of external power supply (DC) | 5 W | 5 W |
| Frequency range AC | 50 - 60 Hz | 50 - 60 Hz |
| Residual ripple DC | 160 % | 160 % |
| Duty cycle | 100 % | 100 % |
| Inputs | 787532 | 787538 |
| Number | 2 | 2 |
| Voltage at | | |
| Input circuit DC | 24 V | 24 V |
| Start circuit DC | 24 V | 24 V |
| Feedback loop DC | 24 V | 24 V |
| Current at | | |
| Input circuit DC | 40 mA | 40 mA |
| Start circuit DC | 40 mA | 40 mA |
| Feedback loop DC | 3 mA | 3 mA |

Safety relays PNOZ X PNOZ XV3.1P

| Inputs | 787532 | 787538 |
|---|--------------|--------------|
| Max. overall cable resistance RI-max | | |
| Single-channel at UB DC | 150 Ohm | 150 Ohm |
| Single-channel at UB AC | 150 Ohm | 150 Ohm |
| Dual-channel without detection of shorts across contacts at UB DC | 200 Ohm | 200 Ohm |
| Dual-channel without detection of shorts across contacts at UB AC | 200 Ohm | 200 Ohm |
| Dual-channel with detection of shorts across contacts at UB DC | 20 Ohm | 20 Ohm |
| Dual-channel with detection of shorts across contacts at UB AC | 20 Ohm | 20 Ohm |
| Relay outputs | 787532 | 787538 |
| Number of output contacts | | |
| Safety contacts (N/O), instantaneous | 3 | 3 |
| Safety contacts (N/O), delayed | 2 | 2 |
| Auxiliary contacts (N/C) | 1 | 1 |
| Max. short circuit current IK | 1 kA | 1 kA |
| Utilisation category | | |
| In accordance with the standard | EN 60947-4-1 | EN 60947-4-1 |
| Utilisation category of safety contacts | | |
| AC1 at | 240 V | 240 V |
| Min. current | 0,01 A | 0,01 A |
| Max. current | 8 A | 8 A |
| Max. power | 2000 VA | 2000 VA |
| DC1 at | 24 V | 24 V |
| Min. current | 0,01 A | 0,01 A |
| Max. current | 8 A | 8 A |
| Max. power | 200 W | 200 W |
| Utilisation category of safety contacts delayed | | |
| AC1 at | 240 V | 240 V |
| Min. current | 0,01 A | 0,01 A |
| Max. current | 8 A | 8 A |
| Max. power | 2000 VA | 2000 VA |
| DC1 at | 24 V | 24 V |
| Min. current | 0,01 A | 0,01 A |
| Max. current | 8 A | 8 A |
| Max. power | 200 W | 200 W |

Safety relays PNOZ X PNOZ XV3.1P

| Relay outputs | 787532 | 787538 |
|---|--------------------------|--------------------------|
| Utilisation category of auxiliary contacts | | |
| AC1 at | 240 V | 240 V |
| Min. current | 0,01 A | 0,01 A |
| Max. current | 8 A | 8 A |
| Max. power | 2000 VA | 2000 VA |
| DC1 at | 24 V | 24 V |
| Min. current | 0,01 A | 0,01 A |
| Max. current | 8 A | 8 A |
| Max. power | 200 W | 200 W |
| Utilisation category | | |
| In accordance with the standard | EN 60947-5-1 | EN 60947-5-1 |
| Utilisation category of safety contacts | | |
| AC15 at | 230 V | 230 V |
| Max. current | 5 A | 5 A |
| DC13 (6 cycles/min) at | 24 V | 24 V |
| Max. current | 7 A | 7 A |
| Utilisation category of safety contacts delayed | | |
| AC15 at | 230 V | 230 V |
| Max. current | 5 A | 5 A |
| DC13 (6 cycles/min) at | 24 V | 24 V |
| Max. current | 7 A | 7 A |
| Utilisation category of auxiliary contacts | | |
| AC15 at | 230 V | 230 V |
| Max. current | 5 A | 5 A |
| DC13 (6 cycles/min) at | 24 V | 24 V |
| Max. current | 7 A | 7 A |
| Utilisation category in accordance with UL | | |
| Voltage | 240 V AC G. P. | 240 V AC G. P. |
| With current | 8 A | 8 A |
| Voltage | 24 V DC Resistive | 24 V DC Resistive |
| With current | 5 A | 5 A |
| Pilot Duty | C300, R300 | C300, R300 |

Safety relays PNOZ X PNOZ XV3.1P

| Relay outputs | 787532 | 787538 |
|--|--------------------------------------|--------------------------------------|
| External contact fuse protection, safety contacts | | |
| In accordance with the standard | EN 60947-5-1 | EN 60947-5-1 |
| Max. melting integral | 240 A²s | 240 A²s |
| Blow-out fuse, quick | 10 A | 10 A |
| Blow-out fuse, slow | 6 A | 6 A |
| Blow-out fuse, gG | 10 A | 10 A |
| Circuit breaker 24V AC/DC, characteristic B/C | 6 A | 6 A |
| External contact fuse protection, delayed safety contacts | | |
| Max. melting integral | 240 A²s | 240 A²s |
| Blow-out fuse, quick | 10 A | 10 A |
| Blow-out fuse, slow | 6 A | 6 A |
| Blow-out fuse, gG | 10 A | 10 A |
| Circuit breaker 24 V AC/DC, characteristic B/C | 6 A | 6 A |
| External contact fuse protection, auxiliary contacts | | |
| Max. melting integral | 240 A²s | 240 A²s |
| Blow-out fuse, quick | 10 A | 10 A |
| Blow-out fuse, slow | 6 A | 6 A |
| Blow-out fuse, gG | 10 A | 10 A |
| Circuit breaker 24 V AC/DC, characteristic B/C | 6 A | 6 A |
| Contact material | AgSnO₂ + 0,2 µm Au | AgSnO₂ + 0,2 µm Au |
| Conventional thermal current while loading several contacts | 787532 | 787538 |
| I _{th} per contact at UB AC; AC1: 240 V, DC1: 24 V | | |
| Conv. therm. current with 1 contact | 8 A | 8 A |
| Conv. therm. current with 2 contacts | 7,8 A | 7,8 A |
| Conv. therm. current with 3 contacts | 6,5 A | 6,5 A |
| Conv. therm. current with 4 contacts | 5,5 A | 5,5 A |
| Conv. therm. current with 5 contacts | 5 A | 5 A |

Safety relays PNOZ X PNOZ XV3.1P

| Conventional thermal current while loading several contacts | 787532 | 787538 |
|--|---|--|
| Ith per contact at UB DC; AC1: 240 V, DC1: 24 V | | |
| Conv. therm. current with 1 contact | 8 A | 8 A |
| Conv. therm. current with 2 contacts | 7,8 A | 7,8 A |
| Conv. therm. current with 3 contacts | 6,5 A | 6,5 A |
| Conv. therm. current with 4 contacts | 5,5 A | 5,5 A |
| Conv. therm. current with 5 contacts | 5 A | 5 A |
| Times | 787532 | 787538 |
| Switch-on delay | | |
| With automatic start typ. | 400 ms | 400 ms |
| With automatic start max. | 550 ms | 550 ms |
| With automatic start after power on typ. | 750 ms | 750 ms |
| With automatic start after power on max. | 1.050 ms | 1.050 ms |
| With monitored start typ. | 35 ms | 35 ms |
| With monitored start max. | 60 ms | 60 ms |
| Delay-on de-energisation | | |
| With E-STOP typ. | 15 ms | 15 ms |
| With E-STOP max. | 30 ms | 30 ms |
| With power failure typ. UB 240 V | 900 ms | 900 ms |
| With power failure max. UB 240 V | 1400 ms | 1400 ms |
| With power failure typ. UB 24 V | 120 ms | 120 ms |
| With power failure max. UB 24 V | 170 ms | 170 ms |
| Recovery time at max. switching frequency 1/s | | |
| After E-STOP | 50 ms +tv | 50 ms +tv |
| After power failure on wide-range power supply | 1450 ms | 1450 ms |
| Delay time tv | 0,1 s, 0,2 s, 0,3 s, 0,4 s, 0,5 s, 0,6 s, 0,7 s, 0,8 s, 1 s, 1,5 s, 2 s, 3 s | 0,3 s, 5 s, 10 s, 20 s, 40 s, 60 s, 80 s, 100 s, 150 s, 200 s, 250 s, 300 s |
| Time accuracy | -15 %/+15 % +50 ms | -15 %/+15 % +50 ms |
| Repetition accuracy | 2 % | 2 % |
| Waiting period with a monitored start | 300 ms | 300 ms |

Safety relays PNOZ X PNOZ XV3.1P

| Times | 787532 | 787538 |
|--|--|--|
| Min. start pulse duration with a monitored start | 30 ms | 30 ms |
| Supply interruption before de-energisation | 20 ms | 20 ms |
| Simultaneity, channel 1 and 2 max. | ∞ | ∞ |
| Environmental data | 787532 | 787538 |
| Climatic suitability | EN 60068-2-78 | EN 60068-2-78 |
| Ambient temperature | | |
| Temperature range | -10 - 55 °C | -10 - 55 °C |
| Storage temperature | | |
| Temperature range | -40 - 85 °C | -40 - 85 °C |
| Climatic suitability | | |
| Humidity | 93 % r. h. at 40 °C | 93 % r. h. at 40 °C |
| Condensation during operation | Not permitted | Not permitted |
| EMC | EN 60947-5-1, EN 61000-6-2, EN 61000-6-4, EN 61326-3-1 | EN 60947-5-1, EN 61000-6-2, EN 61000-6-4, EN 61326-3-1 |
| Vibration | | |
| In accordance with the standard | EN 60068-2-6 | EN 60068-2-6 |
| Frequency | 10 - 55 Hz | 10 - 55 Hz |
| Amplitude | 0,35 mm | 0,35 mm |
| Airgap creepage | | |
| In accordance with the standard | EN 60947-1 | EN 60947-1 |
| Overvoltage category | III / II | III / II |
| Pollution degree | 2 | 2 |
| Rated insulation voltage | 250 V | 250 V |
| Rated impulse withstand voltage | 4 kV | 4 kV |
| Protection type | | |
| Mounting area (e.g. control cabinet) | IP54 | IP54 |
| Housing | IP40 | IP40 |
| Terminals | IP20 | IP20 |
| Mechanical data | 787532 | 787538 |
| Mounting position | Any | Any |
| Mechanical life | 10,000,000 cycles | 10,000,000 cycles |
| Material | | |
| Bottom | PPO UL 94 V0 | PPO UL 94 V0 |
| Front | ABS UL 94 V0 | ABS UL 94 V0 |
| Top | PPO UL 94 V0 | PPO UL 94 V0 |
| Connection type | Spring-loaded terminal | Spring-loaded terminal |
| Mounting type | plug-in | plug-in |

Safety relays PNOZ X PNOZ XV3.1P

| Mechanical data | 787532 | 787538 |
|---|---|---|
| Conductor cross section with spring-loaded terminals: Flexible with/without crimp connector | 0,2 - 1,5 mm ² , 24 - 16 AWG | 0,2 - 1,5 mm ² , 24 - 16 AWG |
| Spring-loaded terminals: Terminal points per connection | 2 | 2 |
| Stripping length with spring-loaded terminals | 8 mm | 8 mm |
| Dimensions | | |
| Height | 101 mm | 101 mm |
| Width | 90 mm | 90 mm |
| Depth | 121 mm | 121 mm |
| Weight | 535 g | 535 g |

Where standards are undated, the 2014-07 latest editions shall apply.

Safety characteristic data

| Operating mode | EN ISO 13849-1: 2015 PL | EN ISO 13849-1: 2015 Category | EN 62061 SIL CL | EN 62061 PFH _D [1/h] | EN ISO 13849-1: 2015 T _M [year] |
|--------------------------------|----------------------------|----------------------------------|--------------------|------------------------------------|---|
| Safety contacts, instantaneous | PL e | Cat. 4 | SIL CL 3 | 2,31E-09 | 20 |
| Safety contacts, delayed <30 s | PL d | Cat. 3 | SIL CL 3 | 2,64E-09 | 20 |
| Safety contacts, delayed ≥30 s | PL c | Cat. 1 | SIL CL 1 | 2,87E-09 | 20 |

All the units used within a safety function must be considered when calculating the safety characteristic data.

Supplementary data

The PFH value depends on the switching frequency and the load on the relay output. If the service life graphs are not accessible, the stated PFH value can be used irrespective of the switching frequency and the load, as the PFH value already considers the relay's B10d value as well as the failure rates of the other components.

Safety relays PNOZ X PNOZ XV3.1P

Service life graph

The service life graphs indicate the number of cycles from which failures due to wear must be expected. The wear is mainly caused by the electrical load; the mechanical load is negligible.

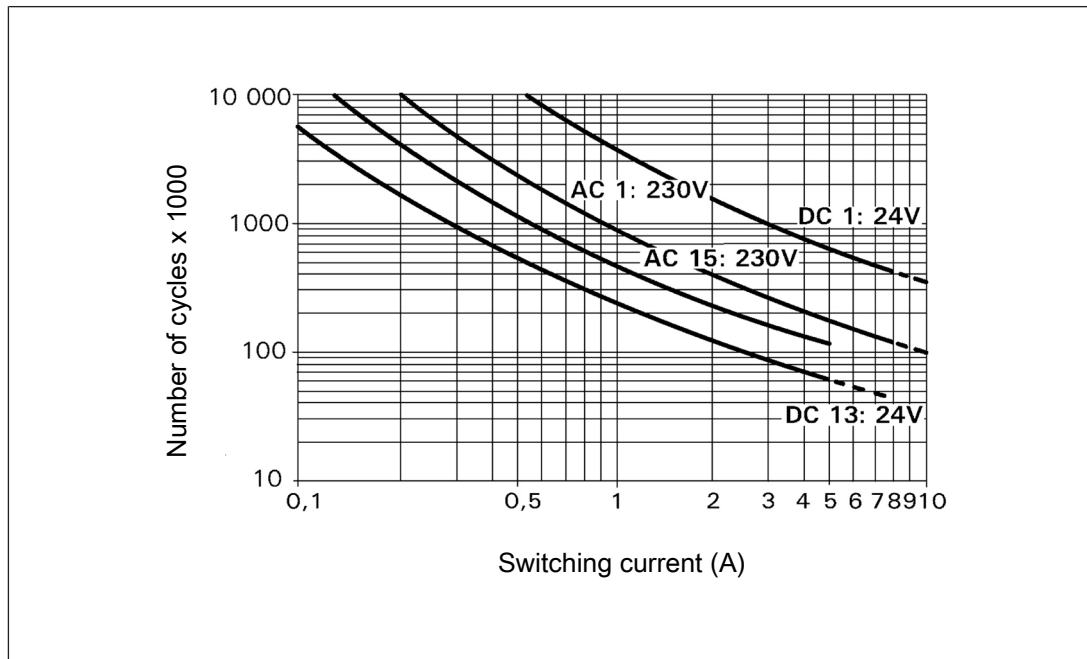

Example

- ▶ Inductive load: 0.2 A
- ▶ Utilisation category: AC15
- ▶ Contact service life: 4 000 000 cycles

Provided the application to be implemented requires fewer than 4 000 000 cycles, the PFH value (see Technical details) can be used in the calculation.

To increase the service life, sufficient spark suppression must be provided on all output contacts. With capacitive loads, any power surges that occur must be noted. With DC contactors, use flywheel diodes for spark suppression.

Safety relays PNOZ X PNOZ XV3.1P

Order reference

| Product type | Features | Connection type | Order no. |
|---------------|---|-------------------------|-----------|
| PNOZ XV3.1P | 24 VDC; Delay: up to 3 s selectable | Screw terminals | 777 522 |
| PNOZ XV3.1P C | 24 VDC; Delay: up to 3 s selectable | Spring-loaded terminals | 787 522 |
| PNOZ XV3.1P | 24 VDC; Delay: 3 s fixed | Screw terminals | 777 525 |
| PNOZ XV3.1P | 24 VDC; Delay: up to 30 s selectable | Screw terminals | 777 520 |
| PNOZ XV3.1P C | 24 VDC; Delay: up to 30 s selectable | Spring-loaded terminals | 787 520 |
| PNOZ XV3.1P | 24 - 240 VAC/DC; Delay: up to 3 s selectable | Screw terminals | 777 532 |
| PNOZ XV3.1P C | 24 - 240 VAC/DC; Delay: up to 3 s selectable | Spring-loaded terminals | 787 532 |
| PNOZ XV3.1P | 24 - 240 VAC/DC; Delay: up to 30 s selectable | Screw terminals | 777 530 |
| PNOZ XV3.1P C | 24 - 240 VAC/DC; Delay: up to 30 s selectable | Spring-loaded terminals | 787 530 |
| PNOZ XV3.1P | 24 - 240 VAC/DC; Delay: up to 300 s selectable | Screw terminals | 777 538 |
| PNOZ XV3.1P C | 24 - 240 VAC/DC; Delay: up to 300 s selectable | Spring-loaded terminals | 787 538 |

Safety relays PNOZ X PZE X4P



Unit features

- ▶ Positive-guided relay outputs:
 - 4 safety contacts (N/O), instantaneous
- ▶ LED display for:
 - Switch status of the safety contacts
- ▶ Connection for feedback loop
- ▶ Operation: single-channel
- ▶ Plug-in connection terminals (either spring-loaded terminal or screw terminal)
- ▶ See order reference for unit types

Block diagram/terminal configuration

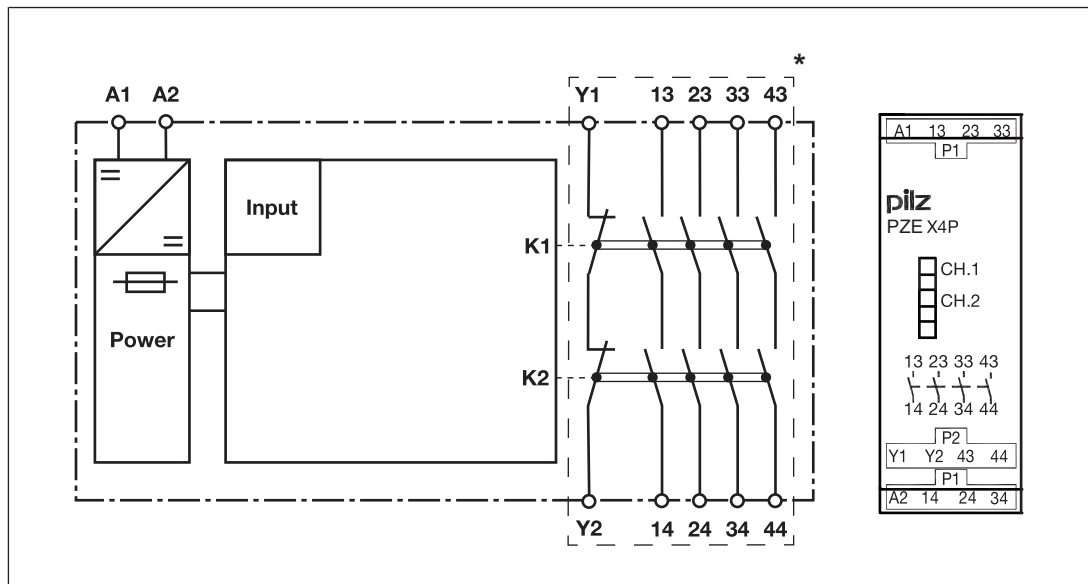

*Insulation between the non-marked area and the relay contacts: Basic insulation (over-voltage category III), Protective separation (overvoltage category II)

Safety relays PNOZ X PZE X4P

Function description

The contact expansion module PZE X4P is an add-on device without delay-on de-energisation, and it is used to expand a safety circuit. The contact expansion module is driven by a base unit (e. g. emergency stop relay).

- ▶ Functional procedure once the input circuit is closed (e.g. safety contacts on the base unit are closed):
 - The supply voltage is present at input (A1) of the contact expansion module.
 - The safety contacts 13-14, 23-24, 33-34 and 43-44 close.
 - The LEDs "CH.1" and "CH.2" are lit.
- ▶ Functional procedure once the input circuit is opened (e.g. safety contacts on the base unit are opened):
 - The supply voltage is not present at input (A1) of the contact expansion module.
 - Safety contacts 13-14, 23-24, 33-34 and 43-44 are opened redundantly.
 - The LEDs "CH.1" and "CH.2" go out.

Installation

- ▶ The unit should be installed in a control cabinet with a protection type of at least IP54.
- ▶ Use the notch on the rear of the unit to attach it to a DIN rail.
- ▶ Ensure the unit is mounted securely on a vertical DIN rail (35 mm) by using a fixing element (e.g. retaining bracket or an end angle).
- ▶ If more than 2 units are installed next to each other in the control cabinet, leave a distance of at least 6 mm between the units.

Wiring

Please note:

- ▶ Information given in the "[Technical details \[412\]](#)" must be followed.
- ▶ The outputs 13-14, 23-24, 33-34 and 43-44 are safety contacts.
- ▶ To prevent contact welding, a fuse should be connected before the output contacts (see [Technical details \[412\]](#)).
- ▶ Calculation of the max. cable length l_{\max} in the input circuit:

$$l_{\max} = \frac{R_{l_{\max}}}{R_l / \text{km}}$$

$R_{l_{\max}}$ = max. overall cable resistance (see [Technical details \[412\]](#))

R_l / km = cable resistance/km

- ▶ Use copper wire that can withstand 60/75 °C.
- ▶ Sufficient fuse protection must be provided on all output contacts with capacitive and inductive loads.

Safety relays PNOZ X PZE X4P

- ▶ Do not switch low currents using contacts that have been used previously with high currents.
- ▶ The power supply must comply with the regulations for extra low voltages with protective electrical separation (SELV, PELV) in accordance with VDE 0100, Part 410.
- ▶ Ensure the wiring and EMC requirements of IEC 60204-1 are met.

Preparing for operation

| Supply voltage | AC | DC |
|--|-------------------|----------------------------------|
| | | |
| Input circuit | Single-channel | Dual-channel |
| Base unit: PNOZ X Driven via safety contacts | | |
| Base unit: PNOZmulti or PNOZelog Driven via semiconductor outputs (24 V DC) | | |
| Feedback loop | Base unit: PNOZ X | Base unit: PNOZmulti or PNOZelog |
| Y1, Y2 and Input are inputs on the base unit; they evaluate the feedback loop | | |

Safety relays PNOZ X PZE X4P

Dimensions in mm

* with spring-loaded terminals

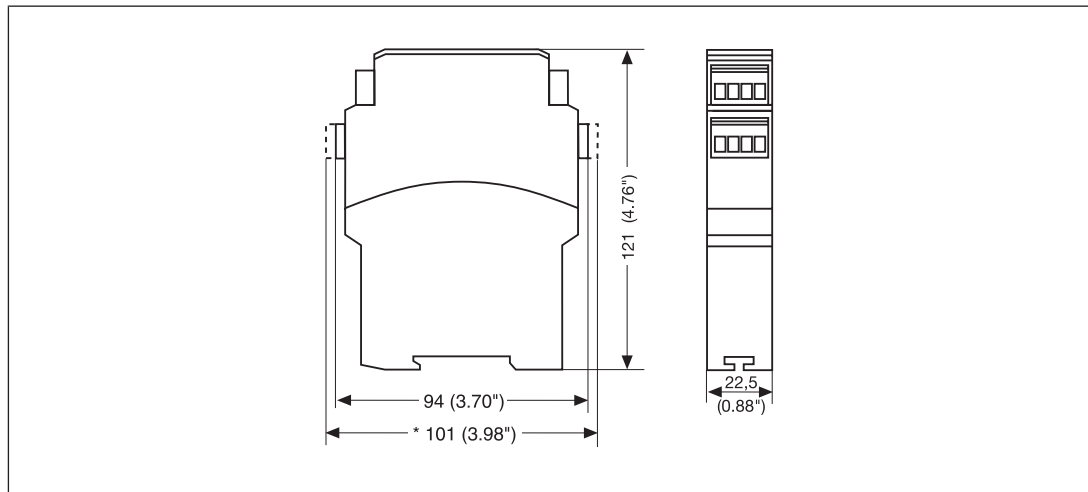

Technical details

| General | 777585 | 787585 |
|--------------------------------------|--|--|
| Approvals | CCC, CE, EAC (Eurasian), TÜV, cULus Listed | CCC, CE, EAC (Eurasian), TÜV, cULus Listed |
| Electrical data | 777585 | 787585 |
| Supply voltage | | |
| Voltage | 24 V | 24 V |
| Kind | DC | DC |
| Voltage tolerance | -15 %/+10 % | -15 %/+10 % |
| Output of external power supply (DC) | 2,5 W | 2,5 W |
| Residual ripple DC | 20 % | 20 % |
| Duty cycle | 100 % | 100 % |
| Max. inrush current impulse | | |
| Current pulse, A1 | 1,7 A | 1,7 A |
| Pulse duration, A1 | 1 ms | 1 ms |
| Inputs | 777585 | 787585 |
| Number | 1 | 1 |
| Voltage at | | |
| Input circuit DC | 24 V | 24 V |
| Current at | | |
| Input circuit DC | 95 mA | 95 mA |

Safety relays PNOZ X PZE X4P

| Inputs | 777585 | 787585 |
|--|--------------------------------------|--------------------------------------|
| Max. overall cable resistance RI-max | | |
| Single-channel at UB DC | 30 Ohm | 30 Ohm |
| Relay outputs | 777585 | 787585 |
| Number of output contacts | | |
| Safety contacts (N/O), instantaneous | 4 | 4 |
| Max. short circuit current IK | 1 kA | 1 kA |
| Utilisation category | | |
| In accordance with the standard | EN 60947-4-1 | EN 60947-4-1 |
| Utilisation category of safety contacts | | |
| AC1 at | 240 V | 240 V |
| Min. current | 0,01 A | 0,01 A |
| Max. current | 6 A | 6 A |
| Max. power | 1500 VA | 1500 VA |
| DC1 at | 24 V | 24 V |
| Min. current | 0,01 A | 0,01 A |
| Max. current | 6 A | 6 A |
| Max. power | 150 W | 150 W |
| Utilisation category | | |
| In accordance with the standard | EN 60947-5-1 | EN 60947-5-1 |
| Utilisation category of safety contacts | | |
| AC15 at | 230 V | 230 V |
| Max. current | 5 A | 5 A |
| DC13 (6 cycles/min) at | 24 V | 24 V |
| Max. current | 5 A | 5 A |
| Utilisation category in accordance with UL | | |
| Voltage | 240 V AC G.U. (same polarity) | 240 V AC G.U. (same polarity) |
| With current | 6 A | 6 A |
| Voltage | 24 V DC G. U. | 24 V DC G. U. |
| With current | 6 A | 6 A |
| Pilot Duty | R300 | R300 |

Safety relays PNOZ X PZE X4P

| Relay outputs | 777585 | 787585 |
|--|----------------------------|----------------------------|
| External contact fuse protection, safety contacts | | |
| In accordance with the standard | EN 60947-5-1 | EN 60947-5-1 |
| Max. melting integral | 260 A²s | 260 A²s |
| Blow-out fuse, quick | 10 A | 10 A |
| Blow-out fuse, slow | 6 A | 6 A |
| Blow-out fuse, gG | 10 A | 10 A |
| Circuit breaker 24V AC/DC, characteristic B/C | 6 A | 6 A |
| Contact material | AgCuNi + 0,2 µm Au | AgCuNi + 0,2 µm Au |
| Conventional thermal current while loading several contacts | 777585 | 787585 |
| I _{th} per contact at UB DC; AC1: 240 V, DC1: 24 V | | |
| Conv. therm. current with 1 contact | 6 A | 6 A |
| Conv. therm. current with 2 contacts | 6 A | 6 A |
| Conv. therm. current with 3 contacts | 5 A | 5 A |
| Conv. therm. current with 4 contacts | 4 A | 4 A |
| Times | 777585 | 787585 |
| Switch-on delay | | |
| With automatic start after power on typ. | 30 ms | 30 ms |
| With automatic start after power on max. | 50 ms | 50 ms |
| Delay-on de-energisation | | |
| With E-STOP typ. | 30 ms | 30 ms |
| With E-STOP max. | 50 ms | 50 ms |
| With power failure typ. | 30 ms | 30 ms |
| With power failure max. | 50 ms | 50 ms |
| Supply interruption before de-energisation | 20 ms | 20 ms |
| Environmental data | 777585 | 787585 |
| Climatic suitability | EN 60068-2-78 | EN 60068-2-78 |
| Ambient temperature | | |
| Temperature range | -10 - 55 °C | -10 - 55 °C |
| Storage temperature | | |
| Temperature range | -40 - 85 °C | -40 - 85 °C |
| Climatic suitability | | |
| Humidity | 93 % r. h. at 40 °C | 93 % r. h. at 40 °C |

Safety relays PNOZ X PZE X4P

| Environmental data | 777585 | 787585 |
|---|---|---|
| Condensation during operation | Not permitted | Not permitted |
| EMC | EN 60947-5-1, EN 61000-6-2, EN 61326-3-1 | EN 60947-5-1, EN 61000-6-2, EN 61326-3-1 |
| Vibration | | |
| In accordance with the standard | EN 60068-2-6 | EN 60068-2-6 |
| Frequency | 10 - 55 Hz | 10 - 55 Hz |
| Amplitude | 0,35 mm | 0,35 mm |
| Airgap creepage | | |
| In accordance with the standard | EN 60947-1 | EN 60947-1 |
| Overvoltage category | III / II | III / II |
| Pollution degree | 2 | 2 |
| Rated insulation voltage | 250 V | 250 V |
| Rated impulse withstand voltage | 4 kV | 4 kV |
| Protection type | | |
| Mounting area (e.g. control cabinet) | IP54 | IP54 |
| Housing | IP40 | IP40 |
| Terminals | IP20 | IP20 |
| Mechanical data | 777585 | 787585 |
| Mounting position | Any | Any |
| Mechanical life | 10,000,000 cycles | 10,000,000 cycles |
| Material | | |
| Bottom | PPO UL 94 V0 | PPO UL 94 V0 |
| Front | ABS UL 94 V0 | ABS UL 94 V0 |
| Top | PPO UL 94 V0 | PPO UL 94 V0 |
| Connection type | Screw terminal | Spring-loaded terminal |
| Mounting type | plug-in | plug-in |
| Conductor cross section with screw terminals | | |
| 1 core flexible | 0,25 - 2,5 mm², 24 - 12 AWG | – |
| 2 core with the same cross section, flexible with crimp connectors, no plastic sleeve | 0,25 - 1 mm², 24 - 16 AWG | – |
| 2 core with the same cross section, flexible without crimp connectors or with TWIN crimp connectors | 0,2 - 1,5 mm², 24 - 16 AWG | – |
| Torque setting with screw terminals | 0,5 Nm | – |
| Conductor cross section with spring-loaded terminals: Flexible with/without crimp connector | – | 0,2 - 1,5 mm², 24 - 16 AWG |
| Spring-loaded terminals: Terminal points per connection | – | 2 |

Safety relays PNOZ X PZE X4P

| Mechanical data | 777585 | 787585 |
|---|---------|---------|
| Stripping length with spring-loaded terminals | – | 8 mm |
| Dimensions | | |
| Height | 94 mm | 101 mm |
| Width | 22,5 mm | 22,5 mm |
| Depth | 121 mm | 121 mm |
| Weight | 170 g | 170 g |

Where standards are undated, the 2014-07 latest editions shall apply.

Safety characteristic data

| Operating Mode | EN ISO 13849-1: 2015 | EN ISO 13849-1: 2015 | EN 62061 SIL CL | EN 62061 PFH _D [1/h] | IEC 61511 SIL | IEC 61511 PFD | EN ISO 13849-1: 2015 T _M [year] |
|----------------|----------------------|----------------------|-----------------|---------------------------------|---------------|---------------|--|
| – | PL e | Cat. 4 | SIL CL 3 | 2,31E-09 | SIL 3 | 2,03E-06 | 20 |

All the units used within a safety function must be considered when calculating the safety characteristic data.

Supplementary data

The PFH value depends on the switching frequency and the load on the relay output. If the service life graphs are not accessible, the stated PFH value can be used irrespective of the switching frequency and the load, as the PFH value already considers the relay's B10d value as well as the failure rates of the other components.

Safety relays PNOZ X PZE X4P

Service life graph

The service life graphs indicate the number of cycles from which failures due to wear must be expected. The wear is mainly caused by the electrical load; the mechanical load is negligible.

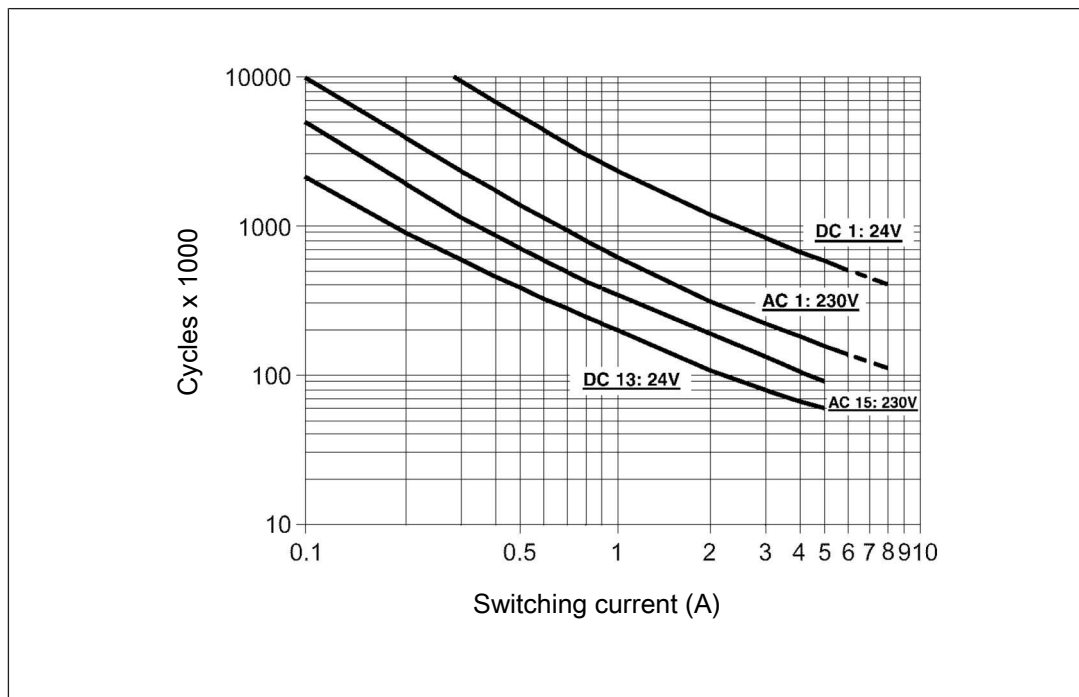

Fig.: Service life graphs at 24 V DC and 230 V AC

Safety relays PNOZ X PZE X4P

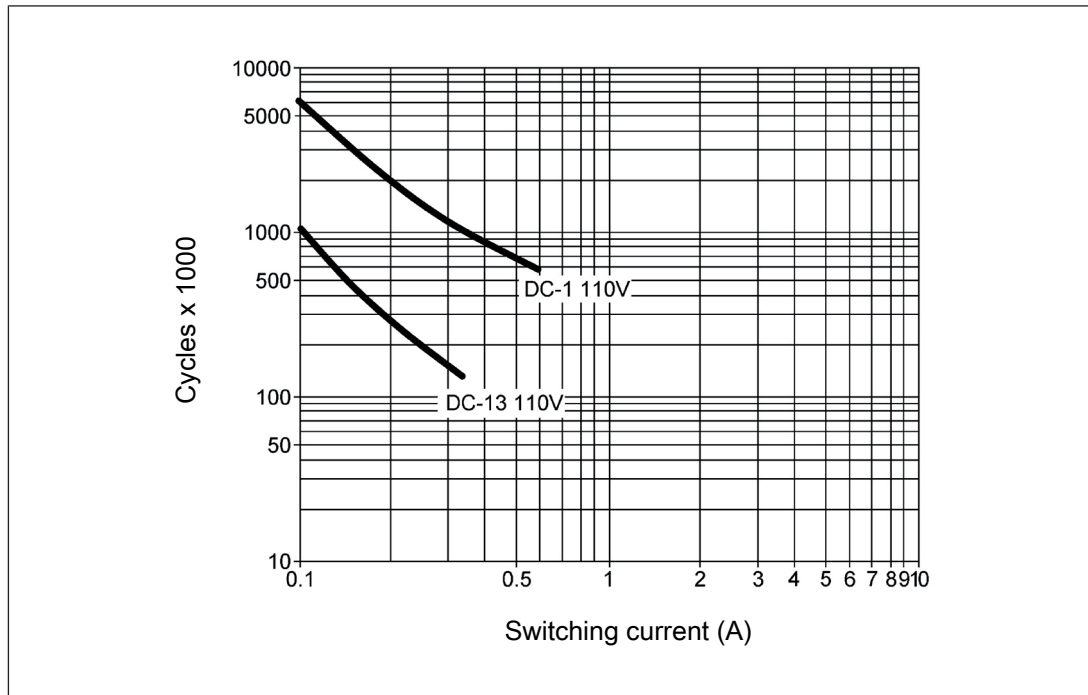

Fig.: Service life graphs at 110 V DC

Example

- ▶ Inductive load: 0.2 A
- ▶ Utilisation category: AC15
- ▶ Contact service life: 2 000 000 cycles

Provided the application to be implemented requires fewer than 2 000 000 cycles, the PFH value (see [Technical details \[412\]](#)) can be used in the calculation.

To increase the service life, sufficient spark suppression must be provided on all output contacts. With capacitive loads, any power surges that occur must be noted. With DC contactors, use flywheel diodes for spark suppression.

Order reference

| Type | Features | Connection type | Order no. |
|-----------|----------|----------------------------------|-----------|
| PZE X4P | 24 VDC | Screw terminals, plug-in | 777 585 |
| PZE X4P C | 24 VDC | Spring-loaded terminals, plug-in | 787 585 |

Safety relays PNOZ X PZE X4.1P



Unit features

- ▶ Positive-guided relay outputs:
 - 4 safety contacts (N/O), instantaneous
- ▶ LED display for:
 - Supply voltage
 - Switch status of the safety contacts
- ▶ Connection for feedback loop
- ▶ Suitable to be driven via OSSD
- ▶ Operation: Single or dual-channel
- ▶ Plug-in connection terminals (either spring-loaded terminal or screw terminal)
- ▶ See order reference for unit types

Safety relays PNOZ X PZE X4.1P

Block diagram/terminal configuration

Type: DC

► U_B : 24 DC; Order no. 777587, 787587

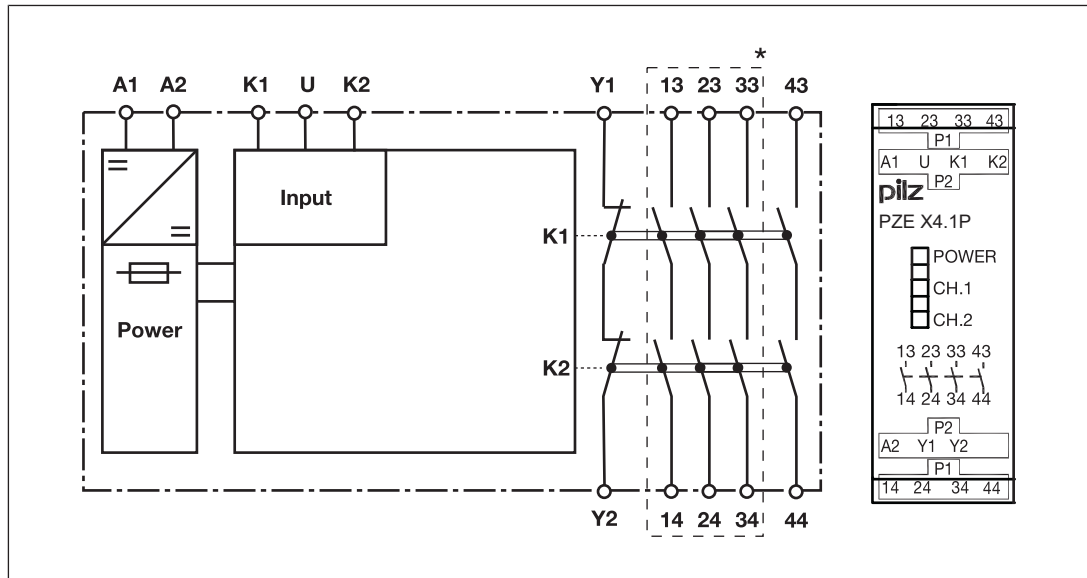

*Safe separation from non-marked area in accordance with EN 60947-1, 6 kV, basic insulation between all safety contacts.

Safety relays PNOZ X PZE X4.1P

Type: AC/DC

- ▶ U_B : 24 - 240 VAC/DC; Order no. 777588, 787588

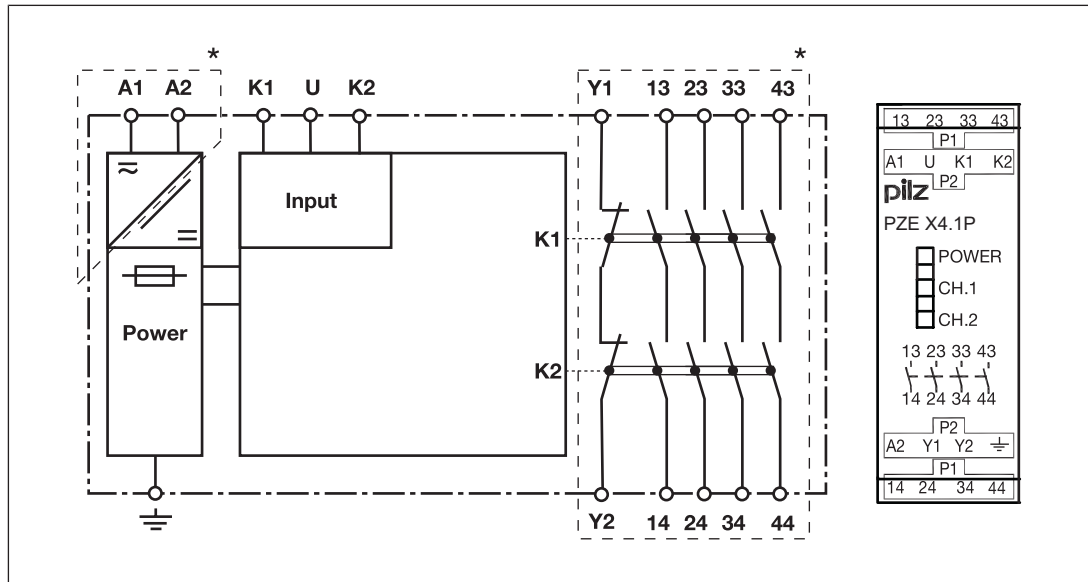

*Insulation between the non-marked area and the relay contacts: Basic insulation (over-voltage category III), Protective separation (overvoltage category II)

Function description

The contact expansion module PZE X4.1P is an add-on device without delay-on de-energisation. It is used to expand a safety circuit. The contact expansion module is driven by a base unit (e. g. emergency stop relay). When operating voltage is supplied the "POWER" LED will light.

- ▶ Functional procedure once the input circuit is closed (e.g. safety contacts on the base unit are closed):
 - The safety contacts 13-14, 23-24, 33-34 and 43-44 close.
 - The LEDs "CH.1" and "CH.2" are lit.
- ▶ Functional procedure once the input circuit is opened (e.g. safety contacts on the base unit are opened):
 - Safety contacts 13-14, 23-24, 33-34 and 43-44 are opened redundantly.
 - The LEDs "CH.1" and "CH.2" go out.

Safety relays PNOZ X PZE X4.1P

Installation

- ▶ The unit should be installed in a control cabinet with a protection type of at least IP54.
- ▶ Use the notch on the rear of the unit to attach it to a DIN rail.
- ▶ Ensure the unit is mounted securely on a vertical DIN rail (35 mm) by using a fixing element (e.g. retaining bracket or an end angle).

Wiring

Please note:

- ▶ Information given in the "[Technical details \[424\]](#)" must be followed.
- ▶ The outputs 13-14, 23-24, 33-34 and 43-44 are safety contacts.
- ▶ Do not connect undesignated terminals.
- ▶ To prevent contact welding, a fuse should be connected before the output contacts (see [Technical details \[424\]](#)).
- ▶ Calculation of the max. cable length l_{\max} in the input circuit:

$$l_{\max} = \frac{R_{l_{\max}}}{R_l / \text{km}}$$

$R_{l_{\max}}$ = max. overall cable resistance (see [Technical details \[424\]](#))

R_l / km = cable resistance/km

- ▶ Use copper wire that can withstand 60/75 °C.
- ▶ Sufficient fuse protection must be provided on all output contacts with capacitive and inductive loads.
- ▶ Do not switch low currents using contacts that have been used previously with high currents.
- ▶ On 24 VDC devices:
The power supply must comply with the regulations for extra low voltages with protective electrical separation (SELV, PELV) in accordance with VDE 0100, Part 410.
- ▶ Ensure the wiring and EMC requirements of IEC 60204-1 are met.

Safety relays PNOZ X PZE X4.1P

Preparing for operation

| Supply voltage | 24 – 240 V AC/DC | 24 VDC |
|--|--------------------------------|---|
| Only when driven via safety relay with safety contacts | | |
| Input circuit | Single-channel | Dual-channel |
| Base unit: Safety relay PNOZ X Driven via safety contacts | | |
| Base unit: PNOZelog safety relay, programmable safety system or PNOZmulti Driven via safe semiconductor outputs (24 VDC) | | |
| Driven via OSSD semiconductor outputs (24 VDC) | | |
| Feedback loop | Base unit: Safety relay PNOZ X | Base unit: PNOZelog safety relay, programmable safety system or PNOZmulti |
| Y1, Y2 and Input are inputs on the base unit; they evaluate the feedback loop | | |

Safety relays PNOZ X PZE X4.1P

Dimensions in mm

* with spring-loaded terminals

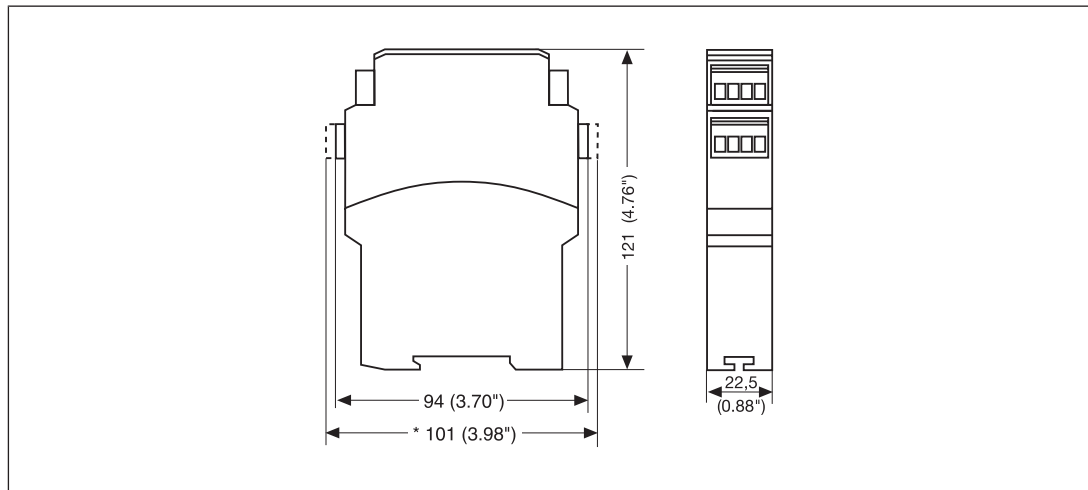

Technical details

Order no. **777587 – 787587**

See below for more order numbers

| General | 777587 | 787587 |
|--------------------------------------|--|--|
| Approvals | CCC, CE, EAC (Eurasian), TÜV, cULus Listed | CCC, CE, EAC (Eurasian), TÜV, cULus Listed |
| Electrical data | 777587 | 787587 |
| Supply voltage | | |
| Voltage | 24 V | 24 V |
| Kind | DC | DC |
| Voltage tolerance | -15 %/+10 % | -15 %/+10 % |
| Output of external power supply (DC) | 2,5 W | 2,5 W |
| Residual ripple DC | 20 % | 20 % |
| Duty cycle | 100 % | 100 % |
| Max. inrush current impulse | | |
| Current pulse, A1 | 1,7 A | 1,7 A |
| Pulse duration, A1 | 1,5 ms | 1,5 ms |
| Inputs | 777587 | 787587 |
| Number | 2 | 2 |
| Voltage at | | |
| Input circuit DC | 24 V | 24 V |

Safety relays PNOZ X PZE X4.1P

| Inputs | 777587 | 787587 |
|---|--------------------------------------|--------------------------------------|
| Current at | | |
| Input circuit DC | 35 mA | 35 mA |
| Max. overall cable resistance RI-max | | |
| Single-channel at UB DC | 30 Ohm | 30 Ohm |
| Dual-channel without detection of shorts across contacts at UB DC | 60 Ohm | 60 Ohm |
| Relay outputs | 777587 | 787587 |
| Number of output contacts | | |
| Safety contacts (N/O), instantaneous | 4 | 4 |
| Max. short circuit current I _K | 1 kA | 1 kA |
| Utilisation category | | |
| In accordance with the standard | EN 60947-4-1 | EN 60947-4-1 |
| Utilisation category of safety contacts | | |
| AC1 at | 240 V | 240 V |
| Min. current | 0,01 A | 0,01 A |
| Max. current | 6 A | 6 A |
| Max. power | 1500 VA | 1500 VA |
| DC1 at | 24 V | 24 V |
| Min. current | 0,01 A | 0,01 A |
| Max. current | 6 A | 6 A |
| Max. power | 150 W | 150 W |
| Utilisation category | | |
| In accordance with the standard | EN 60947-5-1 | EN 60947-5-1 |
| Utilisation category of safety contacts | | |
| AC15 at | 230 V | 230 V |
| Max. current | 3 A | 3 A |
| DC13 (6 cycles/min) at | 24 V | 24 V |
| Max. current | 4 A | 4 A |
| Utilisation category in accordance with UL | | |
| Voltage | 250 V AC G.U. (same polarity) | 250 V AC G.U. (same polarity) |
| With current | 6 A | 6 A |
| Voltage | 24 V DC G. U. | 24 V DC G. U. |
| With current | 6 A | 6 A |
| Pilot Duty | B300, R300 | B300, R300 |

Safety relays PNOZ X PZE X4.1P

| Relay outputs | 777587 | 787587 |
|---|---------------------------|---------------------------|
| External contact fuse protection, safety contacts | | |
| In accordance with the standard | EN 60947-5-1 | EN 60947-5-1 |
| Max. melting integral | 66 A²s | 66 A²s |
| Blow-out fuse, quick | 6 A | 6 A |
| Blow-out fuse, slow | 4 A | 4 A |
| Blow-out fuse, gG | 6 A | 6 A |
| Circuit breaker 24V AC/DC, characteristic B/C | 4 A | 4 A |
| Contact material | AgCuNi + 0,2 µm Au | AgCuNi + 0,2 µm Au |
| Conventional thermal current while loading several contacts | 777587 | 787587 |
| I _{th} per contact at UB DC; AC1: 240 V, DC1: 24 V | | |
| Conv. therm. current with 1 contact | 6 A | 6 A |
| Conv. therm. current with 2 contacts | 6 A | 6 A |
| Conv. therm. current with 3 contacts | 4,5 A | 4,5 A |
| Conv. therm. current with 4 contacts | 3,5 A | 3,5 A |
| Times | 777587 | 787587 |
| Switch-on delay | | |
| With automatic start typ. | 15 ms | 15 ms |
| With automatic start max. | 20 ms | 20 ms |
| With automatic start after power on typ. | 15 ms | 15 ms |
| With automatic start after power on max. | 30 ms | 30 ms |
| Delay-on de-energisation | | |
| With E-STOP typ. | 10 ms | 10 ms |
| With E-STOP max. | 20 ms | 20 ms |
| With power failure typ. | 60 ms | 60 ms |
| With power failure max. | 80 ms | 80 ms |
| Supply interruption before de-energisation in the input circuit | 2 ms | 2 ms |
| Supply interruption before de-energisation | 20 ms | 20 ms |
| Environmental data | 777587 | 787587 |
| Climatic suitability | EN 60068-2-78 | EN 60068-2-78 |
| Ambient temperature | | |
| Temperature range | -10 - 55 °C | -10 - 55 °C |

Safety relays PNOZ X PZE X4.1P

| Environmental data | 777587 | 787587 |
|---|---|---|
| Storage temperature | | |
| Temperature range | -40 - 85 °C | -40 - 85 °C |
| Climatic suitability | | |
| Humidity | 93 % r. h. at 40 °C | 93 % r. h. at 40 °C |
| Condensation during operation | Not permitted | Not permitted |
| EMC | EN 60947-5-1, EN 61000-6-2, EN 61326-3-1 | EN 60947-5-1, EN 61000-6-2, EN 61326-3-1 |
| Vibration | | |
| In accordance with the standard | EN 60068-2-6 | EN 60068-2-6 |
| Frequency | 10 - 55 Hz | 10 - 55 Hz |
| Amplitude | 0,35 mm | 0,35 mm |
| Airgap creepage | | |
| In accordance with the standard | EN 60947-1 | EN 60947-1 |
| Overvoltage category | III | III |
| Pollution degree | 2 | 2 |
| Rated insulation voltage | 250 V | 250 V |
| Rated impulse withstand voltage | 6 kV | 6 kV |
| Protection type | | |
| Mounting area (e.g. control cabinet) | IP54 | IP54 |
| Housing | IP40 | IP40 |
| Terminals | IP20 | IP20 |
| Mechanical data | 777587 | 787587 |
| Mounting position | Any | Any |
| Mechanical life | 10,000,000 cycles | 10,000,000 cycles |
| Material | | |
| Bottom | PPO UL 94 V0 | PPO UL 94 V0 |
| Front | ABS UL 94 V0 | ABS UL 94 V0 |
| Top | PPO UL 94 V0 | PPO UL 94 V0 |
| Connection type | Screw terminal | Spring-loaded terminal |
| Mounting type | plug-in | plug-in |
| Conductor cross section with screw terminals | | |
| 1 core flexible | 0,25 - 2,5 mm², 24 - 12 AWG | – |
| 2 core with the same cross section, flexible with crimp connectors, no plastic sleeve | 0,25 - 1 mm², 24 - 16 AWG | – |
| 2 core with the same cross section, flexible without crimp connectors or with TWIN crimp connectors | 0,2 - 1,5 mm², 24 - 16 AWG | – |
| Torque setting with screw terminals | 0,5 Nm | – |

Safety relays PNOZ X PZE X4.1P

| Mechanical data | 777587 | 787587 |
|---|---------|---|
| Conductor cross section with spring-loaded terminals: Flexible with/without crimp connector | – | 0,2 - 1,5 mm ² , 24 - 16 AWG |
| Spring-loaded terminals: Terminal points per connection | – | 2 |
| Stripping length with spring-loaded terminals | – | 8 mm |
| Dimensions | | |
| Height | 94 mm | 101 mm |
| Width | 22,5 mm | 22,5 mm |
| Depth | 121 mm | 121 mm |
| Weight | 185 g | 185 g |

Where standards are undated, the 2014-07 latest editions shall apply.

Order no. 777588 – 787588

| General | 777588 | 787588 |
|--------------------------------------|--|--|
| Approvals | CCC, CE, EAC (Eurasian), TÜV, cULus Listed | CCC, CE, EAC (Eurasian), TÜV, cULus Listed |
| Electrical data | 777588 | 787588 |
| Supply voltage | | |
| Voltage | 24 - 240 V | 24 - 240 V |
| Kind | AC/DC | AC/DC |
| Voltage tolerance | -15 %/+10 % | -15 %/+10 % |
| Output of external power supply (AC) | 4 VA | 4 VA |
| Output of external power supply (DC) | 2 W | 2 W |
| Frequency range AC | 50 - 60 Hz | 50 - 60 Hz |
| Residual ripple DC | 20 % | 20 % |
| Duty cycle | 100 % | 100 % |
| Inputs | 777588 | 787588 |
| Number | 2 | 2 |
| Voltage at | | |
| Input circuit DC | 24 V | 24 V |
| Current at | | |
| Input circuit DC | 30 mA | 30 mA |

Safety relays PNOZ X PZE X4.1P

| Inputs | 777588 | 787588 |
|---|-------------------------------|-------------------------------|
| Max. overall cable resistance RI-max | | |
| Single-channel at UB DC | 70 Ohm | 70 Ohm |
| Single-channel at UB AC | 70 Ohm | 70 Ohm |
| Dual-channel without detection of shorts across contacts at UB DC | 140 Ohm | 140 Ohm |
| Dual-channel without detection of shorts across contacts at UB AC | 140 Ohm | 140 Ohm |
| Relay outputs | 777588 | 787588 |
| Number of output contacts | | |
| Safety contacts (N/O), instantaneous | 4 | 4 |
| Max. short circuit current IK | | |
| | 1 kA | 1 kA |
| Utilisation category | | |
| In accordance with the standard | EN 60947-4-1 | EN 60947-4-1 |
| Utilisation category of safety contacts | | |
| AC1 at | 240 V | 240 V |
| Min. current | 0,01 A | 0,01 A |
| Max. current | 6 A | 6 A |
| Max. power | 1500 VA | 1500 VA |
| DC1 at | 24 V | 24 V |
| Min. current | 0,01 A | 0,01 A |
| Max. current | 6 A | 6 A |
| Max. power | 150 W | 150 W |
| Utilisation category | | |
| In accordance with the standard | EN 60947-5-1 | EN 60947-5-1 |
| Utilisation category of safety contacts | | |
| AC15 at | 230 V | 230 V |
| Max. current | 3 A | 3 A |
| DC13 (6 cycles/min) at | 24 V | 24 V |
| Max. current | 4 A | 4 A |
| Utilisation category in accordance with UL | | |
| Voltage | 250 V AC G.U. (same polarity) | 250 V AC G.U. (same polarity) |
| With current | 6 A | 6 A |
| Voltage | 24 V DC G. U. | 24 V DC G. U. |
| With current | 6 A | 6 A |
| Pilot Duty | B300, R300 | B300, R300 |

Safety relays PNOZ X PZE X4.1P

| Relay outputs | 777588 | 787588 |
|--|---------------------------|---------------------------|
| External contact fuse protection, safety contacts | | |
| In accordance with the standard | EN 60947-5-1 | EN 60947-5-1 |
| Max. melting integral | 66 A²s | 66 A²s |
| Blow-out fuse, quick | 6 A | 6 A |
| Blow-out fuse, slow | 4 A | 4 A |
| Blow-out fuse, gG | 6 A | 6 A |
| Circuit breaker 24V AC/DC, characteristic B/C | 4 A | 4 A |
| Contact material | AgCuNi + 0,2 µm Au | AgCuNi + 0,2 µm Au |
| Conventional thermal current while loading several contacts | 777588 | 787588 |
| I _{th} per contact at UB AC; AC1: 240 V, DC1: 24 V | | |
| Conv. therm. current with 1 contact | 6 A | 6 A |
| Conv. therm. current with 2 contacts | 6 A | 6 A |
| Conv. therm. current with 3 contacts | 4,5 A | 4,5 A |
| Conv. therm. current with 4 contacts | 3,5 A | 3,5 A |
| I _{th} per contact at UB DC; AC1: 240 V, DC1: 24 V | | |
| Conv. therm. current with 1 contact | 6 A | 6 A |
| Conv. therm. current with 2 contacts | 6 A | 6 A |
| Conv. therm. current with 3 contacts | 4,5 A | 4,5 A |
| Conv. therm. current with 4 contacts | 3,5 A | 3,5 A |
| Times | 777588 | 787588 |
| Switch-on delay | | |
| With automatic start typ. | 15 ms | 15 ms |
| With automatic start max. | 20 ms | 20 ms |
| With automatic start after power on typ. | 230 ms | 230 ms |
| With automatic start after power on max. | 360 ms | 360 ms |

Safety relays PNOZ X PZE X4.1P

| Times | 777588 | 787588 |
|---|--|--|
| Delay-on de-energisation | | |
| With E-STOP typ. | 10 ms | 10 ms |
| With E-STOP max. | 20 ms | 20 ms |
| With power failure typ. UB 240 V | 1300 ms | 1300 ms |
| With power failure max. UB 240 V | 1900 ms | 1900 ms |
| With power failure typ. UB 24 V | 270 ms | 270 ms |
| With power failure max. UB 24 V | 350 ms | 350 ms |
| Supply interruption before de-energisation in the input circuit | 2 ms | 2 ms |
| Supply interruption before de-energisation | 20 ms | 20 ms |
| Environmental data | 777588 | 787588 |
| Climatic suitability | EN 60068-2-78 | EN 60068-2-78 |
| Ambient temperature | | |
| Temperature range | -10 - 55 °C | -10 - 55 °C |
| Storage temperature | | |
| Temperature range | -40 - 85 °C | -40 - 85 °C |
| Climatic suitability | | |
| Humidity | 93 % r. h. at 40 °C | 93 % r. h. at 40 °C |
| Condensation during operation | Not permitted | Not permitted |
| EMC | EN 60947-5-1, EN 61000-6-2, EN 61000-6-4, EN 61326-3-1 | EN 60947-5-1, EN 61000-6-2, EN 61000-6-4, EN 61326-3-1 |
| Vibration | | |
| In accordance with the standard | EN 60068-2-6 | EN 60068-2-6 |
| Frequency | 10 - 55 Hz | 10 - 55 Hz |
| Amplitude | 0,35 mm | 0,35 mm |
| Airgap creepage | | |
| In accordance with the standard | EN 60947-1 | EN 60947-1 |
| Overvoltage category | III / II | III / II |
| Pollution degree | 2 | 2 |
| Rated insulation voltage | 250 V | 250 V |
| Rated impulse withstand voltage | 4 kV | 4 kV |
| Protection type | | |
| Mounting area (e.g. control cabinet) | IP54 | IP54 |
| Housing | IP40 | IP40 |
| Terminals | IP20 | IP20 |
| Mechanical data | 777588 | 787588 |
| Mounting position | Any | Any |
| Mechanical life | 10,000,000 cycles | 10,000,000 cycles |

Safety relays PNOZ X PZE X4.1P

| Mechanical data | 777588 | 787588 |
|---|---|--|
| Material | | |
| Bottom | PPO UL 94 V0 | PPO UL 94 V0 |
| Front | ABS UL 94 V0 | ABS UL 94 V0 |
| Top | PPO UL 94 V0 | PPO UL 94 V0 |
| Connection type | Screw terminal | Spring-loaded terminal |
| Mounting type | plug-in | plug-in |
| Conductor cross section with screw terminals | | |
| 1 core flexible | 0,25 - 2,5 mm², 24 - 12 AWG | – |
| 2 core with the same cross section, flexible with crimp connectors, no plastic sleeve | 0,25 - 1 mm², 24 - 16 AWG | – |
| 2 core with the same cross section, flexible without crimp connectors or with TWIN crimp connectors | 0,2 - 1,5 mm², 24 - 16 AWG | – |
| Torque setting with screw terminals | 0,5 Nm | – |
| Conductor cross section with spring-loaded terminals: Flexible with/without crimp connector | – | 0,2 - 1,5 mm², 24 - 16 AWG |
| Spring-loaded terminals: Terminal points per connection | – | 2 |
| Stripping length with spring-loaded terminals | – | 8 mm |
| Dimensions | | |
| Height | 94 mm | 101 mm |
| Width | 22,5 mm | 22,5 mm |
| Depth | 121 mm | 121 mm |
| Weight | 215 g | 215 g |

Where standards are undated, the 2014-07 latest editions shall apply.

Safety characteristic data

| Operating Mode | EN ISO 13849-1: 2015 | EN ISO 13849-1: 2015 | EN 62061 SIL CL | EN 62061 PFH _D [1/h] | IEC 61511 SIL | IEC 61511 PFD | EN ISO 13849-1: 2015 T _M [year] |
|----------------|----------------------|----------------------|-----------------|---------------------------------|---------------|-----------------|--|
| – | PL e | Cat. 4 | SIL CL 3 | 2,31E-09 | SIL 3 | 2,03E-06 | 20 |

All the units used within a safety function must be considered when calculating the safety characteristic data.

Safety relays PNOZ X PZE X4.1P

Supplementary data

The PFH value depends on the switching frequency and the load on the relay output. If the service life graphs are not accessible, the stated PFH value can be used irrespective of the switching frequency and the load, as the PFH value already considers the relay's B10d value as well as the failure rates of the other components.

Service life graph

The service life graphs indicate the number of cycles from which failures due to wear must be expected. The wear is mainly caused by the electrical load; the mechanical load is negligible.

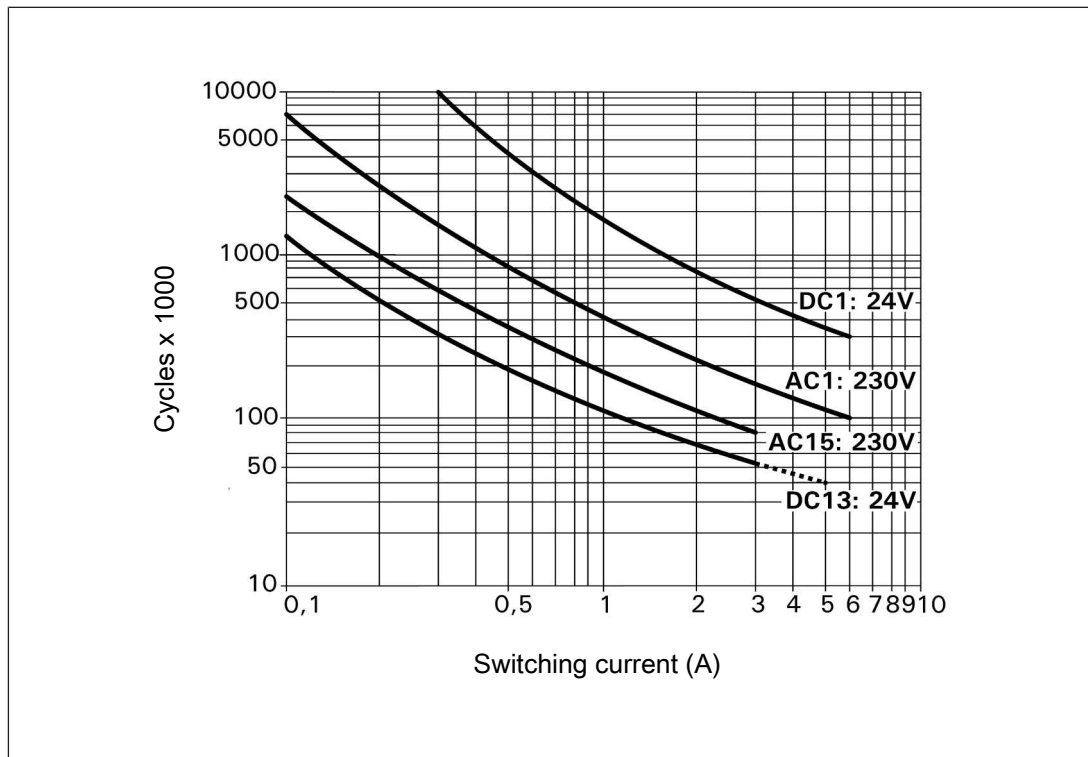

Fig.: Service life graphs at 24 VDC and 230 VAC

Safety relays PNOZ X PZE X4.1P

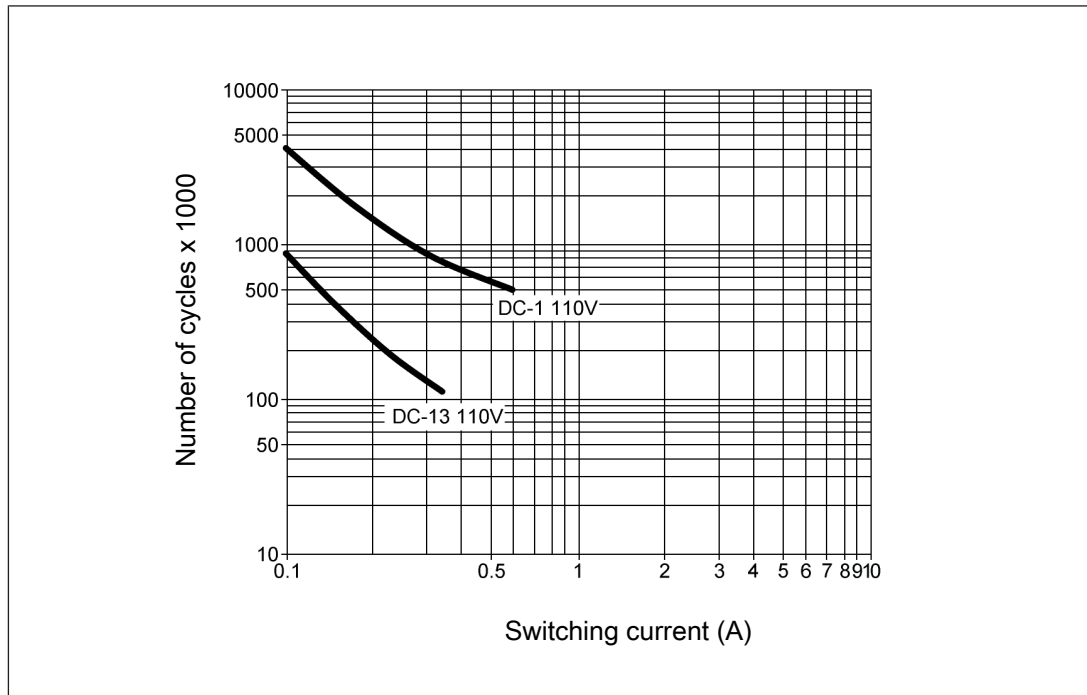

Fig.: Service life graphs at 110 VDC

Example

- ▶ Inductive load: 0.2 A
- ▶ Utilisation category: AC15
- ▶ Contact service life: 1 000 000 cycles

Provided the application to be implemented requires fewer than 1 000 000 cycles, the PFH value (see [Technical details \[424\]](#)) can be used in the calculation.

To increase the service life, sufficient spark suppression must be provided on all relay contacts. With capacitive loads, any power surges that occur must be noted. With DC contactors, use flywheel diodes for spark suppression.

Order reference

| Type | Features | Connection type | Order no. |
|-------------|----------------|----------------------------------|-----------|
| PZE X4.1P | 24 VDC | Screw terminals, plug-in | 777 587 |
| PZE X4.1P C | 24 VDC | Spring-loaded terminals, plug-in | 787 587 |
| PZE X4.1P | 24-240 V AC/DC | Screw terminals, plug-in | 777 588 |
| PZE X4.1P C | 24-240 V AC/DC | Spring-loaded terminals, plug-in | 787 588 |

Safety relays PNOZ X PZE X4VP

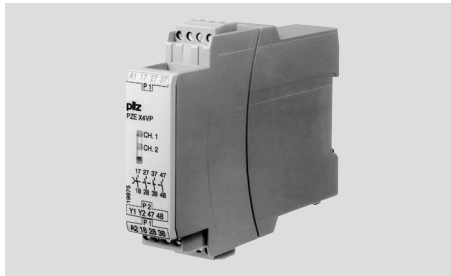

Unit features

- ▶ Positive-guided relay outputs:
 - 4 safety contacts (N/O), delay-on de-energisation
- ▶ LED display for:
 - Switch status of the safety contacts
- ▶ Connection for feedback loop
- ▶ Operation: single-channel
- ▶ Unit types with various delay times
- ▶ Plug-in connection terminals (either spring-loaded terminal or screw terminal)
- ▶ See order reference for unit types

Block diagram/terminal configuration

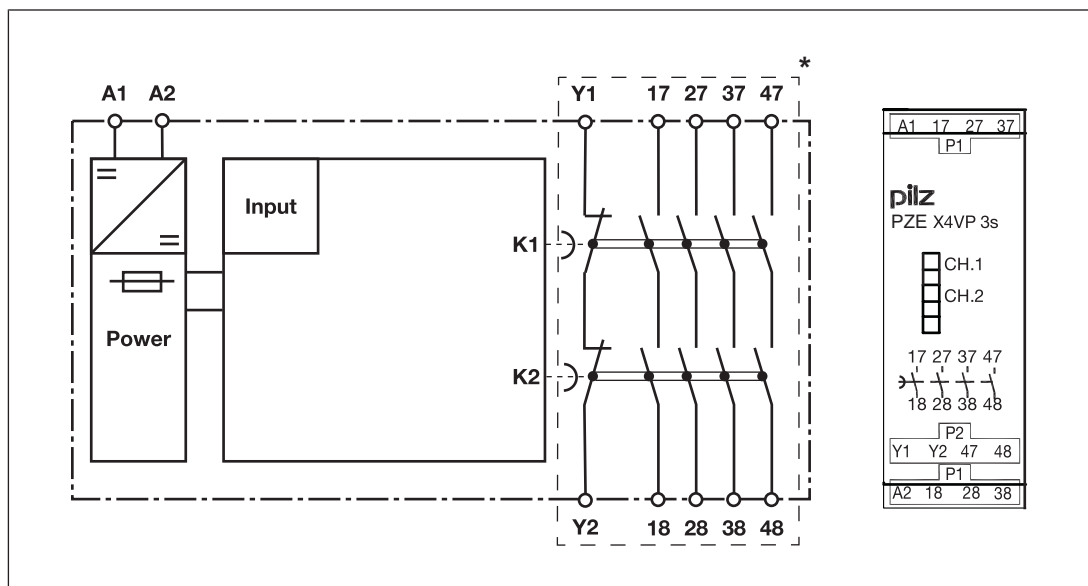

*Insulation between the non-marked area and the relay contacts: Basic insulation (over-voltage category III), Protective separation (overvoltage category II)

Safety relays PNOZ X PZE X4VP

Function description

The contact expansion module PZE X4VP is an add-on device with delay-on de-energisation, and it is used to expand a safety circuit. The contact expansion module is driven by a base unit (e. g. emergency stop relay).

- ▶ Functional procedure once the input circuit is closed (e.g. safety contacts on the base unit are closed):
 - The supply voltage is present at input (A1) of the contact expansion module.
 - The safety contacts 17-18, 27-28, 37-38 and 47-48 close.
 - The LEDs "CH.1" and "CH.2" are lit.
- ▶ Functional procedure once the input circuit is opened (e.g. safety contacts on the base unit are opened):
 - The supply voltage is not present at input (A1) of the contact expansion module.
 - The LEDs "CH.1" and "CH.2" go out.
 - Safety contacts 17-18, 27-28, 37-38 and 47-48 are opened redundantly once the delay time has elapsed.

Installation

- ▶ The unit should be installed in a control cabinet with a protection type of at least IP54.
- ▶ Use the notch on the rear of the unit to attach it to a DIN rail.
- ▶ Ensure the unit is mounted securely on a vertical DIN rail (35 mm) by using a fixing element (e.g. retaining bracket or an end angle).
- ▶ If more than 2 units are installed next to each other in the control cabinet, leave a distance of at least 6 mm between the units.

Wiring

Please note:

- ▶ Information given in the "[Technical details \[438\]](#)" must be followed.
- ▶ Outputs 17-18, 27-28, 37-38 and 47-48 are delay-on de-energisation safety contacts.
- ▶ To prevent contact welding, a fuse should be connected before the output contacts (see [Technical details \[438\]](#)).
- ▶ Calculation of the max. cable length l_{\max} in the input circuit:

$$l_{\max} = \frac{R_{l_{\max}}}{R_1 / \text{km}}$$

$R_{l_{\max}}$ = max. overall cable resistance (see [Technical details \[438\]](#))

R_1 / km = cable resistance/km

- ▶ Use copper wire that can withstand 60/75 °C.
- ▶ Sufficient fuse protection must be provided on all output contacts with capacitive and inductive loads.

Safety relays PNOZ X PZE X4VP

- ▶ Do not switch low currents using contacts that have been used previously with high currents.
- ▶ The power supply must comply with the regulations for extra low voltages with protective electrical separation (SELV, PELV) in accordance with VDE 0100, Part 410.
- ▶ Ensure the wiring and EMC requirements of IEC 60204-1 are met.

Preparing for operation

| Supply voltage | AC | DC |
|--|--------------------------------|--------------|
| | | |
| Input circuit | Single-channel | Dual-channel |
| Base unit: Safety relay PNOZ X Driven via safety contacts | | |
| Feedback loop | Base unit: Safety relay PNOZ X | |
| Y1 and Y2 are inputs on the base unit; they evaluate the feedback loop | | |

Safety relays PNOZ X PZE X4VP

Dimensions in mm

* with spring-loaded terminals

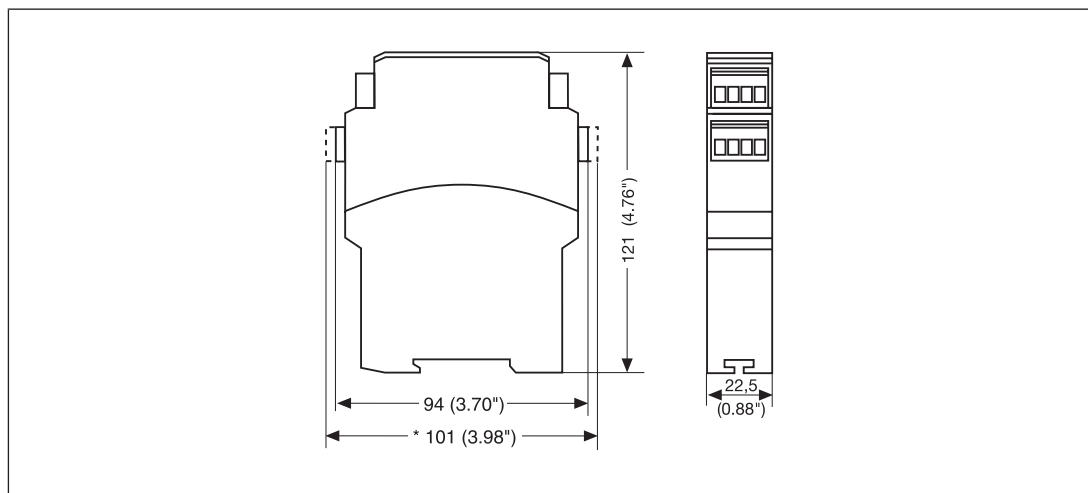

Technical details

Order no. 777580 – 777582

See below for more order numbers

| General | 777580 | 777581 | 777582 |
|--------------------------------------|--|--|--|
| Approvals | CCC, CE, EAC (Eurasian), TÜV, cULus Listed | CCC, CE, EAC (Eurasian), TÜV, cULus Listed | CCC, CE, EAC (Eurasian), TÜV, cULus Listed |
| Electrical data | 777580 | 777581 | 777582 |
| Supply voltage | | | |
| Voltage | 24 V | 24 V | 24 V |
| Kind | DC | DC | DC |
| Voltage tolerance | -15 %/+10 % | -15 %/+10 % | -15 %/+10 % |
| Output of external power supply (DC) | 2,5 W | 2,5 W | 2,5 W |
| Residual ripple DC | 20 % | 20 % | 20 % |
| Duty cycle | 100 % | 100 % | 100 % |
| Max. inrush current impulse | | | |
| Current pulse, A1 | 1,7 A | 1,7 A | 1,7 A |
| Pulse duration, A1 | 50 ms | 100 ms | 140 ms |
| Inputs | 777580 | 777581 | 777582 |
| Number | 1 | 1 | 1 |
| Voltage at | | | |
| Input circuit DC | 24 V | 24 V | 24 V |

Safety relays PNOZ X PZE X4VP

| Inputs | 777580 | 777581 | 777582 |
|---|--------------------------------------|--------------------------------------|--------------------------------------|
| Current at | | | |
| Input circuit DC | 95 mA | 95 mA | 95 mA |
| Max. overall cable resistance R _{lmax} | | | |
| Single-channel at UB DC | 30 Ohm | 30 Ohm | 30 Ohm |
| Relay outputs | 777580 | 777581 | 777582 |
| Number of output contacts | | | |
| Safety contacts (N/O), delayed | 4 | 4 | 4 |
| Max. short circuit current I _K | 1 kA | 1 kA | 1 kA |
| Utilisation category | | | |
| In accordance with the standard | EN 60947-4-1 | EN 60947-4-1 | EN 60947-4-1 |
| Utilisation category of safety contacts delayed | | | |
| AC1 at | 240 V | 240 V | 240 V |
| Min. current | 0,01 A | 0,01 A | 0,01 A |
| Max. current | 6 A | 6 A | 6 A |
| Max. power | 1500 VA | 1500 VA | 1500 VA |
| DC1 at | 24 V | 24 V | 24 V |
| Min. current | 0,01 A | 0,01 A | 0,01 A |
| Max. current | 6 A | 6 A | 6 A |
| Max. power | 150 W | 150 W | 150 W |
| Utilisation category | | | |
| In accordance with the standard | EN 60947-5-1 | EN 60947-5-1 | EN 60947-5-1 |
| Utilisation category of safety contacts delayed | | | |
| AC15 at | 230 V | 230 V | 230 V |
| Max. current | 3 A | 3 A | 3 A |
| DC13 (6 cycles/min) at | 24 V | 24 V | 24 V |
| Max. current | 4 A | 4 A | 4 A |
| Utilisation category in accordance with UL | | | |
| Voltage | 250 V AC G.U. (same polarity) | 250 V AC G.U. (same polarity) | 250 V AC G.U. (same polarity) |
| With current | 6 A | 6 A | 6 A |
| Voltage | 24 V DC G. U. | 24 V DC G. U. | 24 V DC G. U. |
| With current | 6 A | 6 A | 6 A |
| Pilot Duty | B300, R300 | B300, R300 | B300, R300 |

Safety relays PNOZ X PZE X4VP

| Relay outputs | 777580 | 777581 | 777582 |
|--|---------------------|---------------------|---------------------|
| External contact fuse protection, safety contacts | | | |
| In accordance with the standard | EN 60947-5-1 | EN 60947-5-1 | EN 60947-5-1 |
| External contact fuse protection, delayed safety contacts | | | |
| Max. melting integral | 66 A ² s | 66 A ² s | 66 A ² s |
| Blow-out fuse, quick | 6 A | 6 A | 6 A |
| Blow-out fuse, slow | 4 A | 4 A | 4 A |
| Blow-out fuse, gG | 6 A | 6 A | 6 A |
| Circuit breaker 24 V AC/DC, characteristic B/C | 4 A | 4 A | 4 A |
| Contact material | AgCuNi + 0,2 µm Au | AgCuNi + 0,2 µm Au | AgCuNi + 0,2 µm Au |
| Conventional thermal current while loading several contacts | 777580 | 777581 | 777582 |
| I _{th} per contact at UB DC; AC1: 240 V, DC1: 24 V | | | |
| Conv. therm. current with 1 contact | 6 A | 6 A | 6 A |
| Conv. therm. current with 2 contacts | 5 A | 5 A | 5 A |
| Conv. therm. current with 3 contacts | 4,5 A | 4,5 A | 4,5 A |
| Conv. therm. current with 4 contacts | 4 A | 4 A | 4 A |
| Times | 777580 | 777581 | 777582 |
| Switch-on delay | | | |
| With automatic start after power on typ. | 55 ms | 55 ms | 55 ms |
| With automatic start after power on max. | 200 ms | 200 ms | 200 ms |
| Delay time t _v | 0,5 s | 1 s | 2 s |
| Time accuracy | -50 %/+50 % | -50 %/+50 % | -50 %/+50 % |
| Supply interruption before de-energisation | 250 ms | 500 ms | 1.000 ms |
| Environmental data | 777580 | 777581 | 777582 |
| Climatic suitability | EN 60068-2-78 | EN 60068-2-78 | EN 60068-2-78 |
| Ambient temperature | | | |
| Temperature range | -10 - 55 °C | -10 - 55 °C | -10 - 55 °C |
| Storage temperature | | | |
| Temperature range | -40 - 85 °C | -40 - 85 °C | -40 - 85 °C |

Safety relays PNOZ X PZE X4VP

| Environmental data | 777580 | 777581 | 777582 |
|--------------------------------------|--|--|--|
| Climatic suitability | | | |
| Humidity | 93 % r. h. at 40 °C | 93 % r. h. at 40 °C | 93 % r. h. at 40 °C |
| Condensation during operation | | | |
| | Not permitted | Not permitted | Not permitted |
| EMC | | | |
| | EN 60947-5-1, EN 61000-6-2, EN 61326-3-1 | EN 60947-5-1, EN 61000-6-2, EN 61326-3-1 | EN 60947-5-1, EN 61000-6-2, EN 61326-3-1 |
| Vibration | | | |
| In accordance with the standard | EN 60068-2-6 | EN 60068-2-6 | EN 60068-2-6 |
| Frequency | 10 - 55 Hz | 10 - 55 Hz | 10 - 55 Hz |
| Amplitude | 0,35 mm | 0,35 mm | 0,35 mm |
| Airgap creepage | | | |
| In accordance with the standard | EN 60947-1 | EN 60947-1 | EN 60947-1 |
| Overvoltage category | III / II | III / II | III / II |
| Pollution degree | 2 | 2 | 2 |
| Rated insulation voltage | | | |
| | 250 V | 250 V | 250 V |
| Rated impulse withstand voltage | | | |
| | 4 kV | 4 kV | 4 kV |
| Protection type | | | |
| Mounting area (e.g. control cabinet) | IP54 | IP54 | IP54 |
| Housing | IP40 | IP40 | IP40 |
| Terminals | IP20 | IP20 | IP20 |
| Mechanical data | 777580 | 777581 | 777582 |
| Mounting position | Any | Any | Any |
| Mechanical life | 10,000,000 cycles | 10,000,000 cycles | 10,000,000 cycles |
| Material | | | |
| Bottom | PPO UL 94 V0 | PPO UL 94 V0 | PPO UL 94 V0 |
| Front | ABS UL 94 V0 | ABS UL 94 V0 | ABS UL 94 V0 |
| Top | PPO UL 94 V0 | PPO UL 94 V0 | PPO UL 94 V0 |
| Connection type | | | |
| | Screw terminal | Screw terminal | Screw terminal |
| Mounting type | | | |
| | plug-in | plug-in | plug-in |

Safety relays PNOZ X PZE X4VP

| Mechanical data | 777580 | 777581 | 777582 |
|---|--|--|--|
| Conductor cross section with screw terminals | | | |
| 1 core flexible | 0,25 - 2,5 mm ² , 24 - 12 AWG | 0,25 - 2,5 mm ² , 24 - 12 AWG | 0,25 - 2,5 mm ² , 24 - 12 AWG |
| 2 core with the same cross section, flexible with crimp connectors, no plastic sleeve | 0,25 - 1 mm ² , 24 - 16 AWG | 0,25 - 1 mm ² , 24 - 16 AWG | 0,25 - 1 mm ² , 24 - 16 AWG |
| 2 core with the same cross section, flexible without crimp connectors or with TWIN crimp connectors | 0,2 - 1,5 mm ² , 24 - 16 AWG | 0,2 - 1,5 mm ² , 24 - 16 AWG | 0,2 - 1,5 mm ² , 24 - 16 AWG |
| Torque setting with screw terminals | | | |
| | 0,5 Nm | 0,5 Nm | 0,5 Nm |
| Dimensions | | | |
| Height | 94 mm | 94 mm | 94 mm |
| Width | 22,5 mm | 22,5 mm | 22,5 mm |
| Depth | 121 mm | 121 mm | 121 mm |
| Weight | 185 g | 190 g | 205 g |

Where standards are undated, the 2014-07 latest editions shall apply.

Order no. 777583 – 787581

See below for more order numbers

| General | 777583 | 787580 | 787581 |
|--------------------------------------|--|--|--|
| Approvals | CCC, CE, EAC (Eurasian), TÜV, cULus Listed | CCC, CE, EAC (Eurasian), TÜV, cULus Listed | CCC, CE, EAC (Eurasian), TÜV, cULus Listed |
| Electrical data | 777583 | 787580 | 787581 |
| Supply voltage | | | |
| Voltage | 24 V | 24 V | 24 V |
| Kind | DC | DC | DC |
| Voltage tolerance | -15 %/+10 % | -15 %/+10 % | -15 %/+10 % |
| Output of external power supply (DC) | 2,5 W | 2,5 W | 2,5 W |
| Residual ripple DC | 20 % | 20 % | 20 % |
| Duty cycle | 100 % | 100 % | 100 % |
| Max. inrush current impulse | | | |
| Current pulse, A1 | 1,7 A | 1,7 A | 1,7 A |
| Pulse duration, A1 | 180 ms | 50 ms | 100 ms |

Safety relays PNOZ X PZE X4VP

| Inputs | 777583 | 787580 | 787581 |
|---|---------------|---------------|---------------|
| Number | 1 | 1 | 1 |
| Voltage at | | | |
| Input circuit DC | 24 V | 24 V | 24 V |
| Current at | | | |
| Input circuit DC | 95 mA | 95 mA | 95 mA |
| Max. overall cable resistance R _{lmax} | | | |
| Single-channel at UB DC | 30 Ohm | 30 Ohm | 30 Ohm |
| Relay outputs | 777583 | 787580 | 787581 |
| Number of output contacts | | | |
| Safety contacts (N/O), delayed | 4 | 4 | 4 |
| Max. short circuit current I _K | | | |
| | 1 kA | 1 kA | 1 kA |
| Utilisation category | | | |
| In accordance with the standard | EN 60947-4-1 | EN 60947-4-1 | EN 60947-4-1 |
| Utilisation category of safety contacts delayed | | | |
| AC1 at | 240 V | 240 V | 240 V |
| Min. current | 0,01 A | 0,01 A | 0,01 A |
| Max. current | 6 A | 6 A | 6 A |
| Max. power | 1500 VA | 1500 VA | 1500 VA |
| DC1 at | 24 V | 24 V | 24 V |
| Min. current | 0,01 A | 0,01 A | 0,01 A |
| Max. current | 6 A | 6 A | 6 A |
| Max. power | 150 W | 150 W | 150 W |
| Utilisation category | | | |
| In accordance with the standard | EN 60947-5-1 | EN 60947-5-1 | EN 60947-5-1 |
| Utilisation category of safety contacts delayed | | | |
| AC15 at | 230 V | 230 V | 230 V |
| Max. current | 3 A | 3 A | 3 A |
| DC13 (6 cycles/min) at | 24 V | 24 V | 24 V |
| Max. current | 4 A | 4 A | 4 A |

Safety relays PNOZ X PZE X4VP

| Relay outputs | 777583 | 787580 | 787581 |
|--|-------------------------------|-------------------------------|-------------------------------|
| Utilisation category in accordance with UL | | | |
| Voltage | 250 V AC G.U. (same polarity) | 250 V AC G.U. (same polarity) | 250 V AC G.U. (same polarity) |
| With current | 6 A | 6 A | 6 A |
| Voltage | 24 V DC G. U. | 24 V DC G. U. | 24 V DC G. U. |
| With current | 6 A | 6 A | 6 A |
| Pilot Duty | B300, R300 | B300, R300 | B300, R300 |
| External contact fuse protection, safety contacts | | | |
| In accordance with the standard | EN 60947-5-1 | EN 60947-5-1 | EN 60947-5-1 |
| External contact fuse protection, delayed safety contacts | | | |
| Max. melting integral | 66 A ² s | 66 A ² s | 66 A ² s |
| Blow-out fuse, quick | 6 A | 6 A | 6 A |
| Blow-out fuse, slow | 4 A | 4 A | 4 A |
| Blow-out fuse, gG | 6 A | 6 A | 6 A |
| Circuit breaker 24 V AC/DC, characteristic B/C | 4 A | 4 A | 4 A |
| Contact material | AgCuNi + 0,2 µm Au | AgCuNi + 0,2 µm Au | AgCuNi + 0,2 µm Au |
| Conventional thermal current while loading several contacts | 777583 | 787580 | 787581 |
| I _{th} per contact at UB DC; AC1: 240 V, DC1: 24 V | | | |
| Conv. therm. current with 1 contact | 6 A | 6 A | 6 A |
| Conv. therm. current with 2 contacts | 5 A | 5 A | 5 A |
| Conv. therm. current with 3 contacts | 4,5 A | 4,5 A | 4,5 A |
| Conv. therm. current with 4 contacts | 4 A | 4 A | 4 A |
| Times | 777583 | 787580 | 787581 |
| Switch-on delay | | | |
| With automatic start after power on typ. | 55 ms | 55 ms | 55 ms |
| With automatic start after power on max. | 200 ms | 200 ms | 200 ms |
| Delay time t _v | 3 s | 0,5 s | 1 s |
| Time accuracy | -50 %/+50 % | -50 %/+50 % | -50 %/+50 % |

Safety relays PNOZ X PZE X4VP

| Times | 777583 | 787580 | 787581 |
|--|--|--|--|
| Supply interruption before de-energisation | 1.500 ms | 250 ms | 500 ms |
| Environmental data | 777583 | 787580 | 787581 |
| Climatic suitability | EN 60068-2-78 | EN 60068-2-78 | EN 60068-2-78 |
| Ambient temperature | | | |
| Temperature range | -10 - 55 °C | -10 - 55 °C | -10 - 55 °C |
| Storage temperature | | | |
| Temperature range | -40 - 85 °C | -40 - 85 °C | -40 - 85 °C |
| Climatic suitability | | | |
| Humidity | 93 % r. h. at 40 °C | 93 % r. h. at 40 °C | 93 % r. h. at 40 °C |
| Condensation during operation | Not permitted | Not permitted | Not permitted |
| EMC | EN 60947-5-1, EN 61000-6-2, EN 61326-3-1 | EN 60947-5-1, EN 61000-6-2, EN 61326-3-1 | EN 60947-5-1, EN 61000-6-2, EN 61326-3-1 |
| Vibration | | | |
| In accordance with the standard | EN 60068-2-6 | EN 60068-2-6 | EN 60068-2-6 |
| Frequency | 10 - 55 Hz | 10 - 55 Hz | 10 - 55 Hz |
| Amplitude | 0,35 mm | 0,35 mm | 0,35 mm |
| Airgap creepage | | | |
| In accordance with the standard | EN 60947-1 | EN 60947-1 | EN 60947-1 |
| Overvoltage category | III / II | III / II | III / II |
| Pollution degree | 2 | 2 | 2 |
| Rated insulation voltage | 250 V | 250 V | 250 V |
| Rated impulse withstand voltage | 4 kV | 4 kV | 4 kV |
| Protection type | | | |
| Mounting area (e.g. control cabinet) | IP54 | IP54 | IP54 |
| Housing | IP40 | IP40 | IP40 |
| Terminals | IP20 | IP20 | IP20 |
| Mechanical data | 777583 | 787580 | 787581 |
| Mounting position | Any | Any | Any |
| Mechanical life | 10,000,000 cycles | 10,000,000 cycles | 10,000,000 cycles |
| Material | | | |
| Bottom | PPO UL 94 V0 | PPO UL 94 V0 | PPO UL 94 V0 |
| Front | ABS UL 94 V0 | ABS UL 94 V0 | ABS UL 94 V0 |
| Top | PPO UL 94 V0 | PPO UL 94 V0 | PPO UL 94 V0 |
| Connection type | Screw terminal | Spring-loaded terminal | Spring-loaded terminal |
| Mounting type | plug-in | plug-in | plug-in |

Safety relays PNOZ X PZE X4VP

| Mechanical data | 777583 | 787580 | 787581 |
|---|---|--|--|
| Conductor cross section with screw terminals | | | |
| 1 core flexible | 0,25 - 2,5 mm², 24 - 12 AWG | – | – |
| 2 core with the same cross section, flexible with crimp connectors, no plastic sleeve | 0,25 - 1 mm², 24 - 16 AWG | – | – |
| 2 core with the same cross section, flexible without crimp connectors or with TWIN crimp connectors | 0,2 - 1,5 mm², 24 - 16 AWG | – | – |
| Torque setting with screw terminals | 0,5 Nm | – | – |
| Conductor cross section with spring-loaded terminals: Flexible with/without crimp connector | – | 0,2 - 1,5 mm², 24 - 16 AWG | 0,2 - 1,5 mm², 24 - 16 AWG |
| Spring-loaded terminals: Terminal points per connection | – | 2 | 2 |
| Stripping length with spring-loaded terminals | – | 8 mm | 8 mm |
| Dimensions | | | |
| Height | 94 mm | 101 mm | 101 mm |
| Width | 22,5 mm | 22,5 mm | 22,5 mm |
| Depth | 121 mm | 121 mm | 121 mm |
| Weight | 210 g | 185 g | 190 g |

Where standards are undated, the 2014-07 latest editions shall apply.

Safety relays PNOZ X PZE X4VP

Order no. 787582 – 787583

| General | 787582 | 787583 |
|---|--|--|
| Approvals | CCC, CE, EAC (Eurasian), TÜV, cULus Listed | CCC, CE, EAC (Eurasian), TÜV, cULus Listed |
| Electrical data | 787582 | 787583 |
| Supply voltage | | |
| Voltage | 24 V | 24 V |
| Kind | DC | DC |
| Voltage tolerance | -15 %/+10 % | -15 %/+10 % |
| Output of external power supply (DC) | 2,5 W | 2,5 W |
| Residual ripple DC | 20 % | 20 % |
| Duty cycle | 100 % | 100 % |
| Max. inrush current impulse | | |
| Current pulse, A1 | 1,7 A | 1,7 A |
| Pulse duration, A1 | 140 ms | 180 ms |
| Inputs | 787582 | 787583 |
| Number | 1 | 1 |
| Voltage at | | |
| Input circuit DC | 24 V | 24 V |
| Current at | | |
| Input circuit DC | 95 mA | 95 mA |
| Max. overall cable resistance R _I -max | | |
| Single-channel at UB DC | 30 Ohm | 30 Ohm |
| Relay outputs | 787582 | 787583 |
| Number of output contacts | | |
| Safety contacts (N/O), delayed | 4 | 4 |
| Max. short circuit current I _K | 1 kA | 1 kA |
| Utilisation category | | |
| In accordance with the standard | EN 60947-4-1 | EN 60947-4-1 |
| Utilisation category of safety contacts delayed | | |
| AC1 at | 240 V | 240 V |
| Min. current | 0,01 A | 0,01 A |
| Max. current | 6 A | 6 A |
| Max. power | 1500 VA | 1500 VA |
| DC1 at | 24 V | 24 V |
| Min. current | 0,01 A | 0,01 A |
| Max. current | 6 A | 6 A |
| Max. power | 150 W | 150 W |

Safety relays PNOZ X PZE X4VP

| Relay outputs | 787582 | 787583 |
|--|--------------------------------------|--------------------------------------|
| Utilisation category | | |
| In accordance with the standard | EN 60947-5-1 | EN 60947-5-1 |
| Utilisation category of safety contacts delayed | | |
| AC15 at | 230 V | 230 V |
| Max. current | 3 A | 3 A |
| DC13 (6 cycles/min) at | 24 V | 24 V |
| Max. current | 4 A | 4 A |
| Utilisation category in accordance with UL | | |
| Voltage | 250 V AC G.U. (same polarity) | 250 V AC G.U. (same polarity) |
| With current | 6 A | 6 A |
| Voltage | 24 V DC G. U. | 24 V DC G. U. |
| With current | 6 A | 6 A |
| Pilot Duty | B300, R300 | B300, R300 |
| External contact fuse protection, safety contacts | | |
| In accordance with the standard | EN 60947-5-1 | EN 60947-5-1 |
| External contact fuse protection, delayed safety contacts | | |
| Max. melting integral | 66 A²s | 66 A²s |
| Blow-out fuse, quick | 6 A | 6 A |
| Blow-out fuse, slow | 4 A | 4 A |
| Blow-out fuse, gG | 6 A | 6 A |
| Circuit breaker 24 V AC/DC, characteristic B/C | 4 A | 4 A |
| Contact material | AgCuNi + 0,2 µm Au | AgCuNi + 0,2 µm Au |
| Conventional thermal current while loading several contacts | 787582 | 787583 |
| I _{th} per contact at UB DC; AC1: 240 V, DC1: 24 V | | |
| Conv. therm. current with 1 contact | 6 A | 6 A |
| Conv. therm. current with 2 contacts | 5 A | 5 A |
| Conv. therm. current with 3 contacts | 4,5 A | 4,5 A |
| Conv. therm. current with 4 contacts | 4 A | 4 A |

Safety relays PNOZ X PZE X4VP

| Times | 787582 | 787583 |
|--|--|--|
| Switch-on delay | | |
| With automatic start after power on typ. | 55 ms | 55 ms |
| With automatic start after power on max. | 200 ms | 200 ms |
| Delay time tv | 2 s | 3 s |
| Time accuracy | -50 %/+50 % | -50 %/+50 % |
| Supply interruption before de-energisation | 1.000 ms | 1.500 ms |
| Environmental data | 787582 | 787583 |
| Climatic suitability | EN 60068-2-78 | EN 60068-2-78 |
| Ambient temperature | | |
| Temperature range | -10 - 55 °C | -10 - 55 °C |
| Storage temperature | | |
| Temperature range | -40 - 85 °C | -40 - 85 °C |
| Climatic suitability | | |
| Humidity | 93 % r. h. at 40 °C | 93 % r. h. at 40 °C |
| Condensation during operation | Not permitted | Not permitted |
| EMC | EN 60947-5-1, EN 61000-6-2, EN 61326-3-1 | EN 60947-5-1, EN 61000-6-2, EN 61326-3-1 |
| Vibration | | |
| In accordance with the standard | EN 60068-2-6 | EN 60068-2-6 |
| Frequency | 10 - 55 Hz | 10 - 55 Hz |
| Amplitude | 0,35 mm | 0,35 mm |
| Airgap creepage | | |
| In accordance with the standard | EN 60947-1 | EN 60947-1 |
| Overvoltage category | III / II | III / II |
| Pollution degree | 2 | 2 |
| Rated insulation voltage | 250 V | 250 V |
| Rated impulse withstand voltage | 4 kV | 4 kV |
| Protection type | | |
| Mounting area (e.g. control cabinet) | IP54 | IP54 |
| Housing | IP40 | IP40 |
| Terminals | IP20 | IP20 |
| Mechanical data | 787582 | 787583 |
| Mounting position | Any | Any |
| Mechanical life | 10,000,000 cycles | 10,000,000 cycles |
| Material | | |
| Bottom | PPO UL 94 V0 | PPO UL 94 V0 |
| Front | ABS UL 94 V0 | ABS UL 94 V0 |
| Top | PPO UL 94 V0 | PPO UL 94 V0 |

Safety relays PNOZ X PZE X4VP

| Mechanical data | 787582 | 787583 |
|---|---|---|
| Connection type | Spring-loaded terminal | Spring-loaded terminal |
| Mounting type | plug-in | plug-in |
| Conductor cross section with spring-loaded terminals: Flexible with/without crimp connector | 0,2 - 1,5 mm ² , 24 - 16 AWG | 0,2 - 1,5 mm ² , 24 - 16 AWG |
| Spring-loaded terminals: Terminal points per connection | 2 | 2 |
| Stripping length with spring-loaded terminals | 8 mm | 8 mm |
| Dimensions | | |
| Height | 101 mm | 101 mm |
| Width | 22,5 mm | 22,5 mm |
| Depth | 121 mm | 121 mm |
| Weight | 205 g | 210 g |

Where standards are undated, the 2014-07 latest editions shall apply.

Safety characteristic data

| Operating Mode | EN ISO 13849-1: 2015 | EN ISO 13849-1: 2015 | EN 62061 SIL CL | EN 62061 PFH _D [1/h] | IEC 61511 SIL | IEC 61511 PFD | EN ISO 13849-1: 2015 T _M [year] |
|--------------------------------|----------------------|----------------------|-----------------|---------------------------------|---------------|---------------|--|
| | PL | Category | | | | | |
| Safety contacts, delayed <30 s | PL d | Cat. 3 | SIL CL 2 | 2,48E-09 | SIL 2 | 1,47E-05 | 20 |

All the units used within a safety function must be considered when calculating the safety characteristic data.

Supplementary data

The PFH value depends on the switching frequency and the load on the relay output. If the service life graphs are not accessible, the stated PFH value can be used irrespective of the switching frequency and the load, as the PFH value already considers the relay's B10d value as well as the failure rates of the other components.

Safety relays PNOZ X PZE X4VP

Service life graph

The service life graphs indicate the number of cycles from which failures due to wear must be expected. The wear is mainly caused by the electrical load; the mechanical load is negligible.

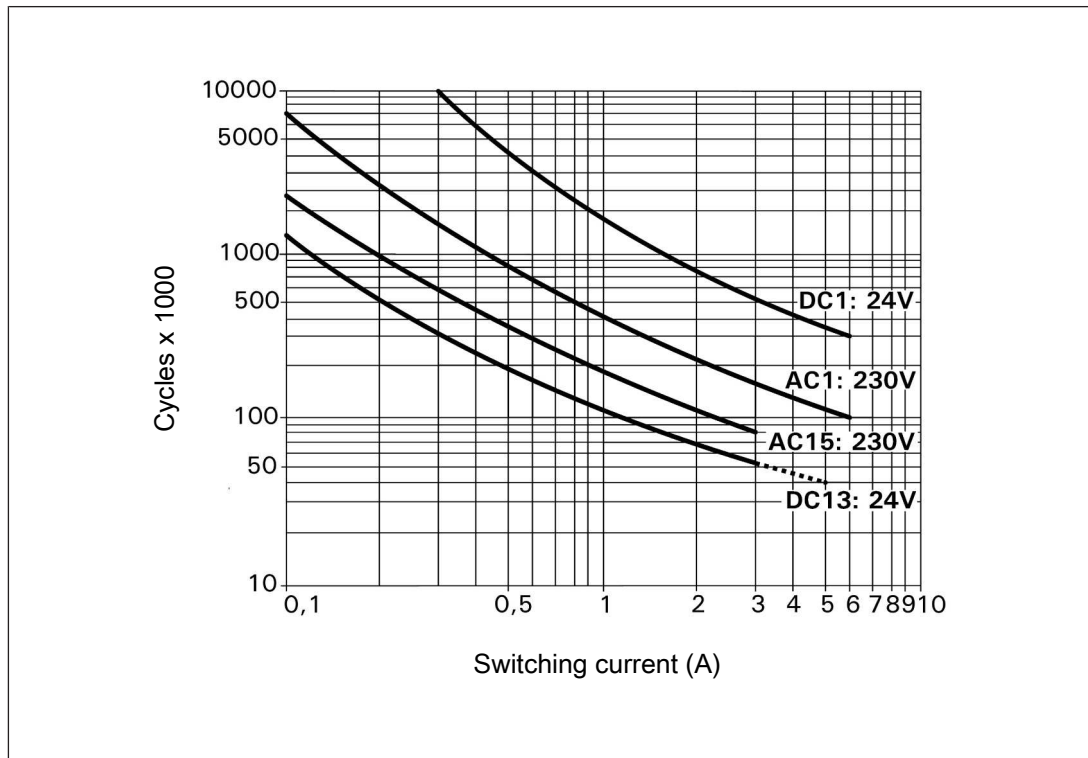

Fig.: Service life graphs at 24 VDC and 230 VAC

Safety relays PNOZ X PZE X4VP

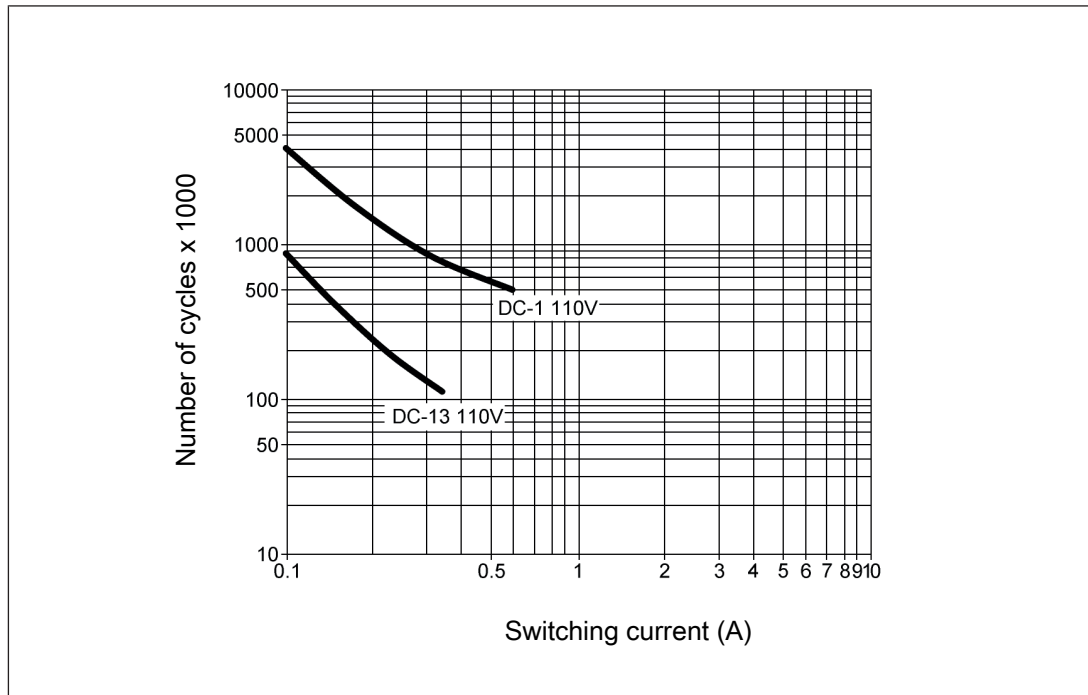

Fig.: Service life graphs at 110 VDC

Example

- ▶ Inductive load: 0.2 A
- ▶ Utilisation category: AC15
- ▶ Contact service life: 1 000 000 cycles

Provided the application to be implemented requires fewer than 1 000 000 cycles, the PFH value (see [Technical details \[438\]](#)) can be used in the calculation.

To increase the service life, sufficient spark suppression must be provided on all relay contacts. With capacitive loads, any power surges that occur must be noted. With DC contactors, use flywheel diodes for spark suppression.

Safety relays PNOZ X PZE X4VP

Order reference

| Type | Features | Connection type | Order no. |
|------------|------------------------|----------------------------------|-----------|
| PZE X4VP | 24 V DC; $t_V = 0.5$ s | Screw terminals, plug-in | 777580 |
| PZE X4VP C | 24 V DC; $t_V = 0.5$ s | Spring-loaded terminals, plug-in | 787580 |
| PZE X4VP | 24 V DC; $t_V = 1$ s | Screw terminals, plug-in | 777581 |
| PZE X4VP C | 24 V DC; $t_V = 1$ s | Spring-loaded terminals, plug-in | 787581 |
| PZE X4VP | 24 V DC; $t_V = 2$ s | Screw terminals, plug-in | 777582 |
| PZE X4VP C | 24 V DC; $t_V = 2$ s | Spring-loaded terminals, plug-in | 787582 |
| PZE X4VP | 24 V DC; $t_V = 3$ s | Screw terminals, plug-in | 777583 |
| PZE X4VP C | 24 V DC; $t_V = 3$ s | Spring-loaded terminals, plug-in | 787583 |

Safety relays PNOZ X PZE X4VP4

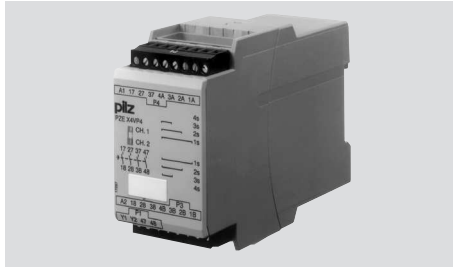

Unit features

- ▶ Positive-guided relay outputs:
 - 4 safety contacts (N/O), delay-on de-energisation
- ▶ LED display for:
 - Switch status of the safety contacts
- ▶ Connection for feedback loop
- ▶ Operation: single-channel
- ▶ Selectable delay time
- ▶ Plug-in connection terminals (either spring-loaded terminal or screw terminal)
- ▶ See order reference for unit types

Block diagram/terminal configuration

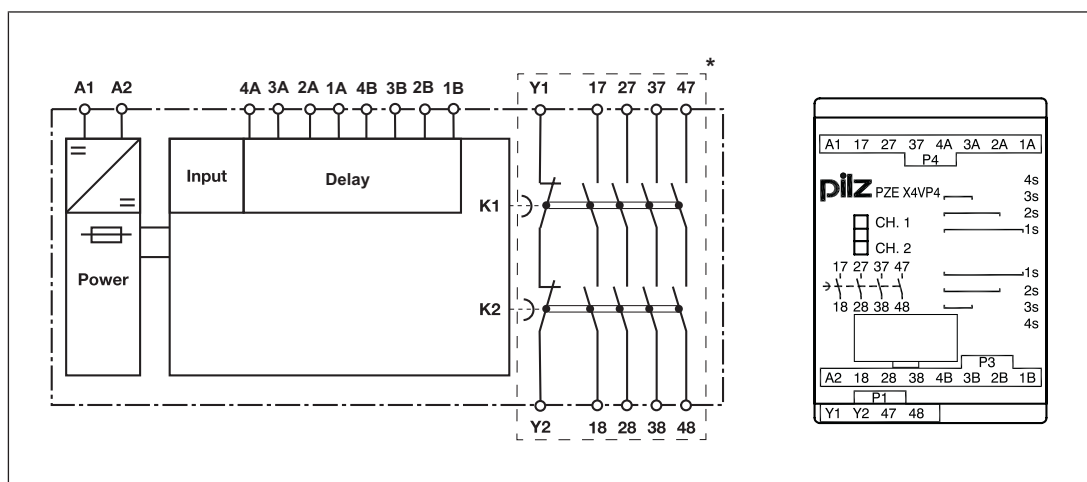

*Insulation between the non-marked area and the relay contacts: Basic insulation (over-voltage category III), Protective separation (overvoltage category II)

Safety relays PNOZ X PZE X4VP4

Function description

The contact expansion module PZE X4VP4 is an add-on device with selectable delay-on de-energisation, and it is used to expand a safety circuit. The contact expansion module is driven by a base unit (e. g. emergency stop relay).

- ▶ Functional procedure once the input circuit is closed (e.g. safety contacts on the base unit are closed):
 - The supply voltage is present at input (A1) of the contact expansion module.
 - The safety contacts 17-18, 27-28, 37-38 and 47-48 close.
 - The LEDs "CH.1" and "CH.2" are lit.
- ▶ Functional procedure once the input circuit is opened (e.g. safety contacts on the base unit are opened):
 - The supply voltage is not present at input (A1) of the contact expansion module.
 - The LEDs "CH.1" and "CH.2" go out.
 - Safety contacts 17-18, 27-28, 37-38 and 47-48 are opened redundantly once the delay time has elapsed.

Installation

- ▶ The unit should be installed in a control cabinet with a protection type of at least IP54.
- ▶ Use the notch on the rear of the unit to attach it to a DIN rail.
- ▶ Ensure the unit is mounted securely on a vertical DIN rail (35 mm) by using a fixing element (e.g. retaining bracket or an end angle).

Wiring

Please note:

- ▶ Information given in the "[Technical details !\[\]\(dce81645e0100714e86d66fe4d06ecba_img.jpg\) 457](#)" must be followed.
- ▶ Outputs 17-18, 27-28, 37-38 and 47-48 are delay-on de-energisation safety contacts.
- ▶ To prevent contact welding, a fuse should be connected before the output contacts (see [Technical details !\[\]\(2f7100595fe61fbdc3e7ec71332af01e_img.jpg\) 457](#)).
- ▶ Calculation of the max. cable length l_{\max} in the input circuit:

$$l_{\max} = \frac{R_{l_{\max}}}{R_l / \text{km}}$$

$R_{l_{\max}}$ = max. overall cable resistance (see [Technical details !\[\]\(c444627dab9fee9a1550c053ffaaaae2_img.jpg\) 457](#))

R_l / km = cable resistance/km

- ▶ Use copper wire that can withstand 60/75 °C.
- ▶ Sufficient fuse protection must be provided on all output contacts with capacitive and inductive loads.
- ▶ Do not switch low currents using contacts that have been used previously with high currents.

Safety relays PNOZ X PZE X4VP4

- ▶ The power supply must comply with the regulations for extra low voltages with protective electrical separation (SELV, PELV) in accordance with VDE 0100, Part 410.
- ▶ Ensure the wiring and EMC requirements of IEC 60204-1 are met.

Preparing for operation

| Supply voltage | AC | DC |
|----------------|----|----|
| | / | |

| Input circuit | Single-channel | Dual-channel |
|---|----------------|--------------|
| Base unit: Safety relay PNOZ X Driven via safety contacts | | / |

| Feedback loop | Base unit: Safety relay PNOZ X | |
|--|--------------------------------|---|
| Y1 and Y2 are inputs on the base unit; they evaluate the feedback loop | | / |

| Setting the delay time | | | |
|------------------------|-----|-----|-----|
| 1 s | 2 s | 3 s | 4 s |
| | | | |

Safety relays PNOZ X PZE X4VP4

Dimensions in mm

* with spring-loaded terminals

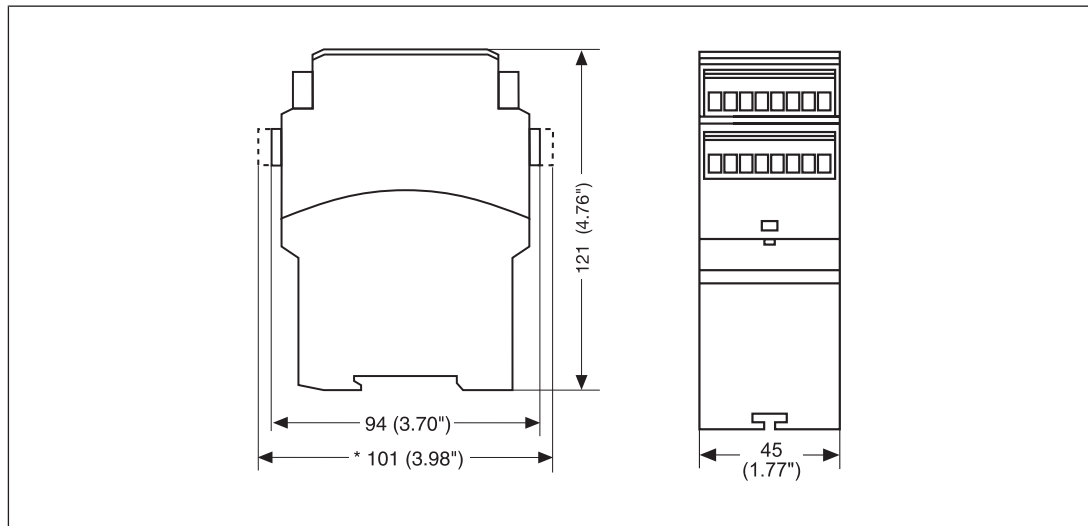

Technical details

| General | 777586 | 787586 |
|--------------------------------------|--|--|
| Approvals | CCC, CE, EAC (Eurasian), TÜV, cULus Listed | CCC, CE, EAC (Eurasian), TÜV, cULus Listed |
| Electrical data | 777586 | 787586 |
| Supply voltage | | |
| Voltage | 24 V | 24 V |
| Kind | DC | DC |
| Voltage tolerance | -15 %/+10 % | -15 %/+10 % |
| Output of external power supply (DC) | 2,5 W | 2,5 W |
| Residual ripple DC | 20 % | 20 % |
| Duty cycle | 100 % | 100 % |
| Max. inrush current impulse | | |
| Current pulse, A1 | 1,7 A | 1,7 A |
| Pulse duration, A1 | 180 ms | 180 ms |
| Inputs | 777586 | 787586 |
| Number | 1 | 1 |
| Voltage at | | |
| Input circuit DC | 24 V | 24 V |
| Current at | | |
| Input circuit DC | 70 mA | 70 mA |

Safety relays PNOZ X PZE X4VP4

| Inputs | 777586 | 787586 |
|---|-------------------------------|-------------------------------|
| Max. overall cable resistance RI-max | | |
| Single-channel at UB DC | 30 Ohm | 30 Ohm |
| Relay outputs | 777586 | 787586 |
| Number of output contacts | | |
| Safety contacts (N/O), delayed | 4 | 4 |
| Max. short circuit current IK | 1 kA | 1 kA |
| Utilisation category | | |
| In accordance with the standard | EN 60947-4-1 | EN 60947-4-1 |
| Utilisation category of safety contacts delayed | | |
| AC1 at | 240 V | 240 V |
| Min. current | 0,01 A | 0,01 A |
| Max. current | 5 A | 5 A |
| Max. power | 1200 VA | 1200 VA |
| DC1 at | 24 V | 24 V |
| Min. current | 0,01 A | 0,01 A |
| Max. current | 5 A | 5 A |
| Max. power | 120 W | 120 W |
| Utilisation category | | |
| In accordance with the standard | EN 60947-5-1 | EN 60947-5-1 |
| Utilisation category of safety contacts delayed | | |
| AC15 at | 230 V | 230 V |
| Max. current | 5 A | 5 A |
| DC13 (6 cycles/min) at | 24 V | 24 V |
| Max. current | 4 A | 4 A |
| Utilisation category in accordance with UL | | |
| Voltage | 240 V AC G.U. (same polarity) | 240 V AC G.U. (same polarity) |
| With current | 5 A | 5 A |
| Voltage | 24 V DC Resistive | 24 V DC Resistive |
| With current | 5 A | 5 A |
| Pilot Duty | B300, R300 | B300, R300 |
| External contact fuse protection, safety contacts | | |
| In accordance with the standard | EN 60947-5-1 | EN 60947-5-1 |

Safety relays PNOZ X PZE X4VP4

| Relay outputs | 777586 | 787586 |
|---|--|--|
| External contact fuse protection, delayed safety contacts | | |
| Max. melting integral | 100 A ² s | 100 A ² s |
| Blow-out fuse, quick | 6 A | 6 A |
| Blow-out fuse, slow | 4 A | 4 A |
| Blow-out fuse, gG | 6 A | 6 A |
| Circuit breaker 24 V AC/DC, characteristic B/C | 4 A | 4 A |
| Conventional thermal current | 5 A | 5 A |
| Contact material | AgSnO ₂ + 0,2 µm Au | AgSnO ₂ + 0,2 µm Au |
| Times | 777586 | 787586 |
| Switch-on delay | | |
| With automatic start after power on typ. | 230 ms | 230 ms |
| With automatic start after power on max. | 400 ms | 400 ms |
| Delay time tv | 1 s, 2 s, 3 s, 4 s | 1 s, 2 s, 3 s, 4 s |
| Time accuracy | -50 %/+50 % | -50 %/+50 % |
| Supply interruption before de-energisation | 500 ms | 500 ms |
| Environmental data | 777586 | 787586 |
| Climatic suitability | EN 60068-2-78 | EN 60068-2-78 |
| Ambient temperature | | |
| Temperature range | -10 - 55 °C | -10 - 55 °C |
| Storage temperature | | |
| Temperature range | -40 - 85 °C | -40 - 85 °C |
| Climatic suitability | | |
| Humidity | 93 % r. h. at 40 °C | 93 % r. h. at 40 °C |
| Condensation during operation | Not permitted | Not permitted |
| EMC | EN 60947-5-1, EN 61000-6-2, EN 61326-3-1 | EN 60947-5-1, EN 61000-6-2, EN 61326-3-1 |
| Vibration | | |
| In accordance with the standard | EN 60068-2-6 | EN 60068-2-6 |
| Frequency | 10 - 55 Hz | 10 - 55 Hz |
| Amplitude | 0,35 mm | 0,35 mm |
| Airgap creepage | | |
| In accordance with the standard | EN 60947-1 | EN 60947-1 |
| Overvoltage category | III / II | III / II |
| Pollution degree | 2 | 2 |
| Rated insulation voltage | 250 V | 250 V |
| Rated impulse withstand voltage | 4 kV | 4 kV |

Safety relays PNOZ X PZE X4VP4

| Environmental data | 777586 | 787586 |
|---|---|--|
| Protection type | | |
| Mounting area (e.g. control cabinet) | IP54 | IP54 |
| Housing | IP40 | IP40 |
| Terminals | IP20 | IP20 |
| Mechanical data | 777586 | 787586 |
| Mounting position | Any | Any |
| Mechanical life | 10,000,000 cycles | 10,000,000 cycles |
| Material | | |
| Bottom | PPO UL 94 V0 | PPO UL 94 V0 |
| Front | ABS UL 94 V0 | ABS UL 94 V0 |
| Top | PPO UL 94 V0 | PPO UL 94 V0 |
| Connection type | Screw terminal | Spring-loaded terminal |
| Mounting type | plug-in | plug-in |
| Conductor cross section with screw terminals | | |
| 1 core flexible | 0,25 - 2,5 mm², 24 - 12 AWG | – |
| 2 core with the same cross section, flexible with crimp connectors, no plastic sleeve | 0,25 - 1 mm², 24 - 16 AWG | – |
| 2 core with the same cross section, flexible without crimp connectors or with TWIN crimp connectors | 0,2 - 1,5 mm², 24 - 16 AWG | – |
| Torque setting with screw terminals | 0,5 Nm | – |
| Conductor cross section with spring-loaded terminals: Flexible with/without crimp connector | – | 0,2 - 1,5 mm², 24 - 16 AWG |
| Spring-loaded terminals: Terminal points per connection | – | 2 |
| Stripping length with spring-loaded terminals | – | 8 mm |
| Dimensions | | |
| Height | 94 mm | 101 mm |
| Width | 45 mm | 45 mm |
| Depth | 121 mm | 121 mm |
| Weight | 300 g | 300 g |

Where standards are undated, the 2014-07 latest editions shall apply.

Safety relays PNOZ X PZE X4VP4

Safety characteristic data

| Operating Mode | EN ISO 13849-1: 2015 PL | EN ISO 13849-1: 2015 Category | EN 62061 SIL CL | EN 62061 PFH _D [1/h] | IEC 61511 SIL | IEC 61511 PFD | EN ISO 13849-1: 2015 T _M [year] |
|--------------------------------|----------------------------|----------------------------------|--------------------|------------------------------------|------------------|------------------|---|
| Safety contacts, delayed <30 s | PL d | Cat. 3 | SIL CL 2 | 2,48E-09 | SIL 2 | 1,47E-05 | 20 |

All the units used within a safety function must be considered when calculating the safety characteristic data.

Supplementary data

The PFH value depends on the switching frequency and the load on the relay output. If the service life graphs are not accessible, the stated PFH value can be used irrespective of the switching frequency and the load, as the PFH value already considers the relay's B10d value as well as the failure rates of the other components.

Safety relays PNOZ X PZE X4VP4

Service life graph

The service life graphs indicate the number of cycles from which failures due to wear must be expected. The wear is mainly caused by the electrical load; the mechanical load is negligible.

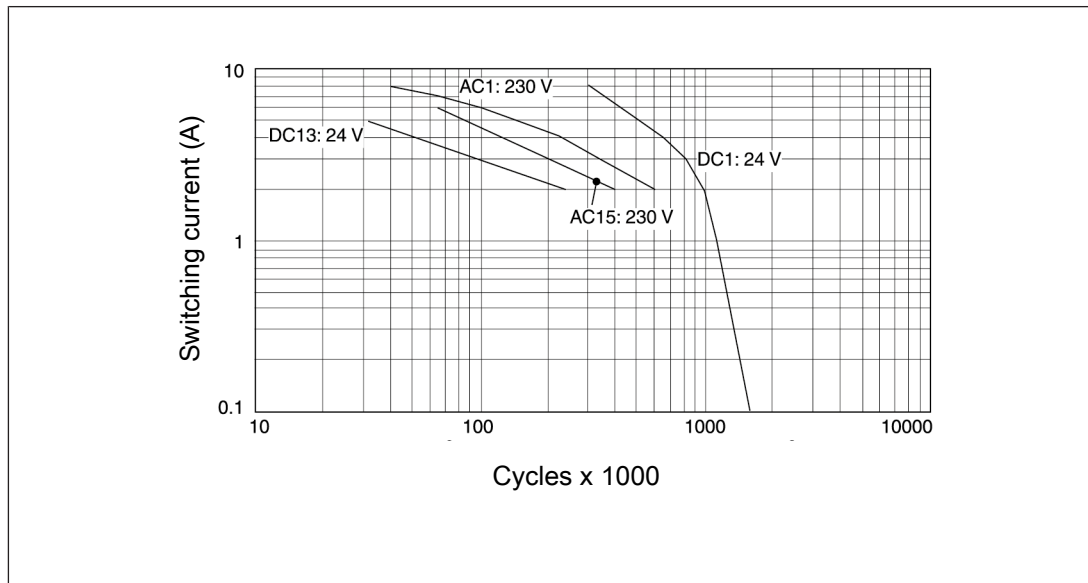

Example

- ▶ Inductive load: 2 A
- ▶ Utilisation category AC15
- ▶ Contact service life: 400 000 cycles

Provided the application to be implemented requires fewer than 400 000 cycles, the PFH value (see Technical details) can be used in the calculation.

To increase the service life, sufficient spark suppression must be provided on all output contacts. With capacitive loads, any power surges that occur must be noted. With DC contacts, use flywheel diodes for spark suppression.

Order reference

| Type | Features | Connection type | Order no. |
|-------------|------------------------------------|----------------------------------|-----------|
| PZE X4VP4 | 24 V DC tv: 1 - 4 s, selectable | Screw terminals, plug-in | 777586 |
| PZE X4VP4 C | 24 V DC tv: 1 - 4 s, selectable | Spring-loaded terminals, plug-in | 787586 |

Safety relays PNOZ X PZE X4VP8

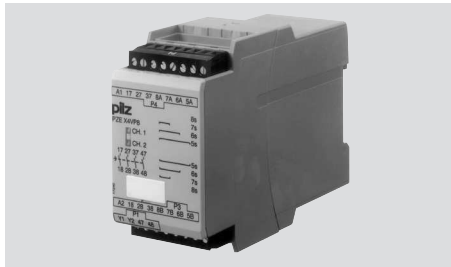

Unit features

- ▶ Positive-guided relay outputs:
 - 4 safety contacts (N/O), delay-on de-energisation
- ▶ LED display for:
 - Switch status of the safety contacts
- ▶ Connection for feedback loop
- ▶ Operation: single-channel
- ▶ Selectable delay time
- ▶ Plug-in connection terminals (either spring-loaded terminal or screw terminal)
- ▶ See order reference for unit types

Block diagram/terminal configuration

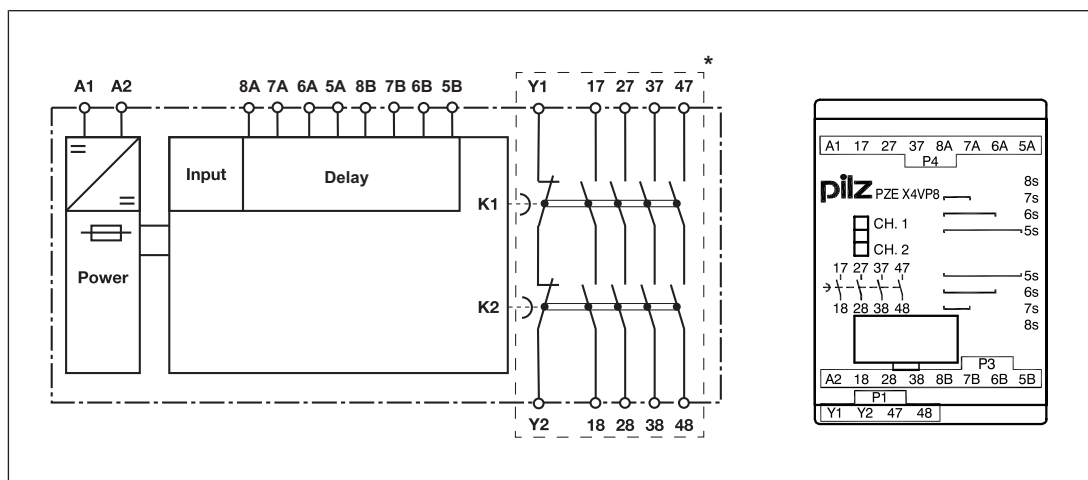

*Insulation between the non-marked area and the relay contacts: Basic insulation (over-voltage category III), Protective separation (overvoltage category II)

Safety relays PNOZ X PZE X4VP8

Function description

The contact expansion module PZE X4VP8 is an add-on device with selectable delay-on de-energisation, and it is used to expand a safety circuit. The contact expansion module is driven by a base unit (e. g. emergency stop relay).

- ▶ Functional procedure once the input circuit is closed (e.g. safety contacts on the base unit are closed):
 - The supply voltage is present at input (A1) of the contact expansion module.
 - The safety contacts 17-18, 27-28, 37-38 and 47-48 close.
 - The LEDs "CH.1" and "CH.2" are lit.
- ▶ Functional procedure once the input circuit is opened (e.g. safety contacts on the base unit are opened):
 - The supply voltage is not present at input (A1) of the contact expansion module.
 - The LEDs "CH.1" and "CH.2" go out.
 - Safety contacts 17-18, 27-28, 37-38 and 47-48 are opened redundantly once the delay time has elapsed.

Installation

- ▶ The unit should be installed in a control cabinet with a protection type of at least IP54.
- ▶ Use the notch on the rear of the unit to attach it to a DIN rail.
- ▶ Ensure the unit is mounted securely on a vertical DIN rail (35 mm) by using a fixing element (e.g. retaining bracket or an end angle).

Wiring

Please note:

- ▶ Information given in the "[Technical details \[466\]](#)" must be followed.
- ▶ Outputs 17-18, 27-28, 37-38 and 47-48 are delay-on de-energisation safety contacts.
- ▶ To prevent contact welding, a fuse should be connected before the output contacts (see [Technical details \[466\]](#)).
- ▶ Calculation of the max. cable length l_{\max} in the input circuit:

$$l_{\max} = \frac{R_{l_{\max}}}{R_l / \text{km}}$$

$R_{l_{\max}}$ = max. overall cable resistance (see [Technical details \[466\]](#))

R_l / km = cable resistance/km

- ▶ Use copper wire that can withstand 60/75 °C.
- ▶ Sufficient fuse protection must be provided on all output contacts with capacitive and inductive loads.
- ▶ Do not switch low currents using contacts that have been used previously with high currents.

Safety relays PNOZ X PZE X4VP8

- ▶ The power supply must comply with the regulations for extra low voltages with protective electrical separation (SELV, PELV) in accordance with VDE 0100, Part 410.
- ▶ Ensure the wiring and EMC requirements of IEC 60204-1 are met.

Preparing for operation

| Supply voltage | AC | DC |
|--|--------------------------------|--------------|
| | | |
| Input circuit | Single-channel | Dual-channel |
| Base unit: Safety relay PNOZ X Driven via safety contacts | | |
| Feedback loop | Base unit: Safety relay PNOZ X | |
| Y1 and Y2 are inputs on the base unit; they evaluate the feedback loop | | |

Setting the delay time

| 5 s | 6 s | 7 s | 8 s |
|-----|-----|-----|-----|
| | | | |

Safety relays PNOZ X PZE X4VP8

Dimensions in mm

* with spring-loaded terminals

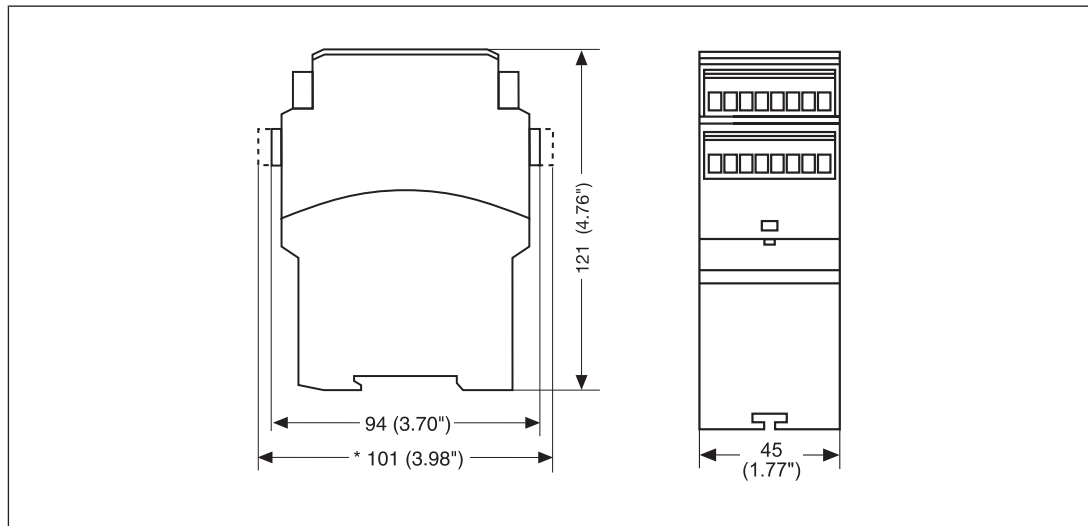

Technical details

| General | 777584 | 787584 |
|--------------------------------------|--|--|
| Approvals | CCC, CE, EAC (Eurasian), TÜV, cULus Listed | CCC, CE, EAC (Eurasian), TÜV, cULus Listed |
| Electrical data | 777584 | 787584 |
| Supply voltage | | |
| Voltage | 24 V | 24 V |
| Kind | DC | DC |
| Voltage tolerance | -15 %/+10 % | -15 %/+10 % |
| Output of external power supply (DC) | 2,5 W | 2,5 W |
| Residual ripple DC | 20 % | 20 % |
| Duty cycle | 100 % | 100 % |
| Max. inrush current impulse | | |
| Current pulse, A1 | 1,7 A | 1,7 A |
| Pulse duration, A1 | 280 ms | 280 ms |
| Inputs | 777584 | 787584 |
| Number | 1 | 1 |
| Voltage at | | |
| Input circuit DC | 24 V | 24 V |
| Current at | | |
| Input circuit DC | 70 mA | 70 mA |

Safety relays PNOZ X PZE X4VP8

| Inputs | 777584 | 787584 |
|---|--------------------------------------|--------------------------------------|
| Max. overall cable resistance RI-max | | |
| Single-channel at UB DC | 30 Ohm | 30 Ohm |
| Relay outputs | 777584 | 787584 |
| Number of output contacts | | |
| Safety contacts (N/O), delayed | 4 | 4 |
| Max. short circuit current IK | 1 kA | 1 kA |
| Utilisation category | | |
| In accordance with the standard | EN 60947-4-1 | EN 60947-4-1 |
| Utilisation category of safety contacts delayed | | |
| AC1 at | 240 V | 240 V |
| Min. current | 0,01 A | 0,01 A |
| Max. current | 5 A | 5 A |
| Max. power | 1200 VA | 1200 VA |
| DC1 at | 24 V | 24 V |
| Min. current | 0,01 A | 0,01 A |
| Max. current | 5 A | 5 A |
| Max. power | 120 W | 120 W |
| Utilisation category | | |
| In accordance with the standard | EN 60947-5-1 | EN 60947-5-1 |
| Utilisation category of safety contacts delayed | | |
| AC15 at | 230 V | 230 V |
| Max. current | 5 A | 5 A |
| DC13 (6 cycles/min) at | 24 V | 24 V |
| Max. current | 4 A | 4 A |
| Utilisation category in accordance with UL | | |
| Voltage | 240 V AC G.U. (same polarity) | 240 V AC G.U. (same polarity) |
| With current | 5 A | 5 A |
| Voltage | 24 V DC Resistive | 24 V DC Resistive |
| With current | 5 A | 5 A |
| Pilot Duty | B300, R300 | B300, R300 |
| External contact fuse protection, safety contacts | | |
| In accordance with the standard | EN 60947-5-1 | EN 60947-5-1 |

Safety relays PNOZ X PZE X4VP8

| Relay outputs | 777584 | 787584 |
|---|--|--|
| External contact fuse protection, delayed safety contacts | | |
| Max. melting integral | 100 A ² s | 100 A ² s |
| Blow-out fuse, quick | 6 A | 6 A |
| Blow-out fuse, slow | 4 A | 4 A |
| Blow-out fuse, gG | 6 A | 6 A |
| Circuit breaker 24 V AC/DC, characteristic B/C | 4 A | 4 A |
| Conventional thermal current | 5 A | 5 A |
| Contact material | AgSnO ₂ + 0,2 µm Au | AgSnO ₂ + 0,2 µm Au |
| Times | 777584 | 787584 |
| Switch-on delay | | |
| With automatic start after power on typ. | 320 ms | 320 ms |
| With automatic start after power on max. | 500 ms | 500 ms |
| Delay time tv | 5 s, 6 s, 7 s, 8 s | 5 s, 6 s, 7 s, 8 s |
| Time accuracy | -50 %/+50 % | -50 %/+50 % |
| Supply interruption before de-energisation | 2.500 ms | 2.500 ms |
| Environmental data | 777584 | 787584 |
| Climatic suitability | EN 60068-2-78 | EN 60068-2-78 |
| Ambient temperature | | |
| Temperature range | -10 - 55 °C | -10 - 55 °C |
| Storage temperature | | |
| Temperature range | -40 - 85 °C | -40 - 85 °C |
| Climatic suitability | | |
| Humidity | 93 % r. h. at 40 °C | 93 % r. h. at 40 °C |
| Condensation during operation | Not permitted | Not permitted |
| EMC | EN 60947-5-1, EN 61000-6-2, EN 61326-3-1 | EN 60947-5-1, EN 61000-6-2, EN 61326-3-1 |
| Vibration | | |
| In accordance with the standard | EN 60068-2-6 | EN 60068-2-6 |
| Frequency | 10 - 55 Hz | 10 - 55 Hz |
| Amplitude | 0,35 mm | 0,35 mm |
| Airgap creepage | | |
| In accordance with the standard | EN 60947-1 | EN 60947-1 |
| Overvoltage category | III / II | III / II |
| Pollution degree | 2 | 2 |
| Rated insulation voltage | 250 V | 250 V |
| Rated impulse withstand voltage | 4 kV | 4 kV |

Safety relays PNOZ X PZE X4VP8

| Environmental data | 777584 | 787584 |
|---|---|--|
| Protection type | | |
| Mounting area (e.g. control cabinet) | IP54 | IP54 |
| Housing | IP40 | IP40 |
| Terminals | IP20 | IP20 |
| Mechanical data | 777584 | 787584 |
| Mounting position | Any | Any |
| Mechanical life | 10,000,000 cycles | 10,000,000 cycles |
| Material | | |
| Bottom | PPO UL 94 V0 | PPO UL 94 V0 |
| Front | ABS UL 94 V0 | ABS UL 94 V0 |
| Top | PPO UL 94 V0 | PPO UL 94 V0 |
| Connection type | Screw terminal | Spring-loaded terminal |
| Mounting type | plug-in | plug-in |
| Conductor cross section with screw terminals | | |
| 1 core flexible | 0,25 - 2,5 mm², 24 - 12 AWG | – |
| 2 core with the same cross section, flexible with crimp connectors, no plastic sleeve | 0,25 - 1 mm², 24 - 16 AWG | – |
| 2 core with the same cross section, flexible without crimp connectors or with TWIN crimp connectors | 0,2 - 1,5 mm², 24 - 16 AWG | – |
| Torque setting with screw terminals | 0,5 Nm | – |
| Conductor cross section with spring-loaded terminals: Flexible with/without crimp connector | – | 0,2 - 1,5 mm², 24 - 16 AWG |
| Spring-loaded terminals: Terminal points per connection | – | 2 |
| Stripping length with spring-loaded terminals | – | 8 mm |
| Dimensions | | |
| Height | 94 mm | 101 mm |
| Width | 45 mm | 45 mm |
| Depth | 121 mm | 121 mm |
| Weight | 320 g | 320 g |

Where standards are undated, the 2014-07 latest editions shall apply.

Safety relays PNOZ X PZE X4VP8

Safety characteristic data

| Operating Mode | EN ISO 13849-1: 2015 PL | EN ISO 13849-1: 2015 Category | EN 62061 SIL CL | EN 62061 PFH _D [1/h] | IEC 61511 SIL | IEC 61511 PFD | EN ISO 13849-1: 2015 T _M [year] |
|--------------------------------|----------------------------|----------------------------------|--------------------|------------------------------------|------------------|------------------|---|
| Safety contacts, delayed <30 s | PL d | Cat. 3 | SIL CL 2 | 2,48E-09 | SIL 2 | 1,47E-05 | 20 |

All the units used within a safety function must be considered when calculating the safety characteristic data.

Supplementary data

The PFH value depends on the switching frequency and the load on the relay output. If the service life graphs are not accessible, the stated PFH value can be used irrespective of the switching frequency and the load, as the PFH value already considers the relay's B10d value as well as the failure rates of the other components.

Safety relays PNOZ X PZE X4VP8

Service life graph

The service life graphs indicate the number of cycles from which failures due to wear must be expected. The wear is mainly caused by the electrical load; the mechanical load is negligible.

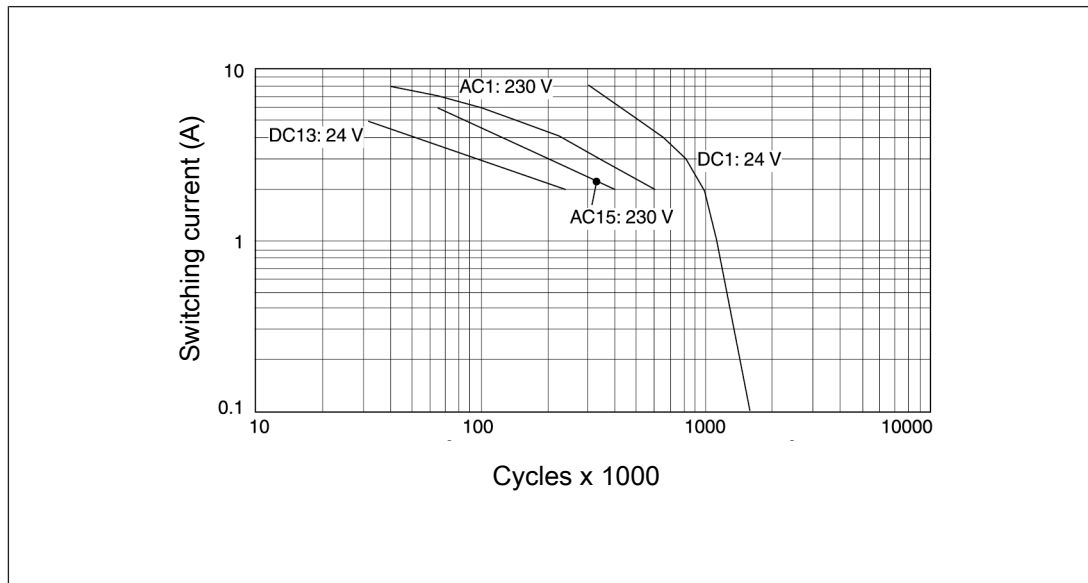

Example

- ▶ Inductive load: 2 A
- ▶ Utilisation category AC15
- ▶ Contact service life: 400 000 cycles

Provided the application to be implemented requires fewer than 400 000 cycles, the PFH value (see Technical details) can be used in the calculation.

To increase the service life, sufficient spark suppression must be provided on all output contacts. With capacitive loads, any power surges that occur must be noted. With DC contactors, use flywheel diodes for spark suppression.

Order reference

| Type | Features | Connection type | Order no. |
|-------------|------------------------------------|----------------------------------|-----------|
| PZE X4VP8 | 24 V DC tv: 5 - 8 s, selectable | Screw terminals, plug-in | 777584 |
| PZE X4VP8 C | 24 V DC tv: 5 - 8 s, selectable | Spring-loaded terminals, plug-in | 787584 |

Safety relays PNOZ X PZE X5P

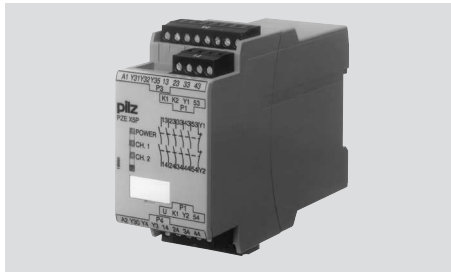

Unit features

- ▶ Positive-guided relay outputs:
 - 5 safety contacts (N/O), instantaneous
- ▶ 2 semiconductor outputs
- ▶ LED display for:
 - Supply voltage
 - Switch status of the safety contacts
- ▶ Semiconductor outputs signal:
 - Supply voltage is present
 - Switch status of the safety contacts
- ▶ Connection for feedback loop
- ▶ Operation: single or dual-channel

Block diagram/terminal configuration

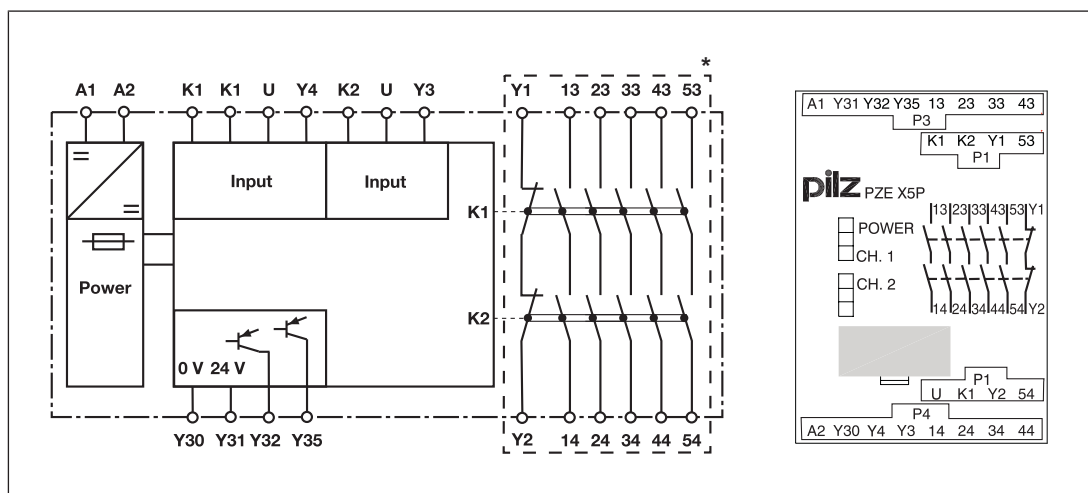

*Insulation between the non-marked area and the relay contacts: Basic insulation (over-voltage category III), Protective separation (overvoltage category II)

Safety relays PNOZ X PZE X5P

Function description

The contact expansion module PZE X5P is an add-on device without delay-on de-energisation, and it is used to expand a safety circuit. The contact expansion module is driven by a base unit (e. g. emergency stop relay). When operating voltage is supplied the "POWER" LED will light.

- ▶ Functional procedure once the input circuit is closed (e.g. safety contacts on the base unit are closed):
 - Safety contacts 13-14, 23-24, 33-34, 43-44 and 53-54 close.
 - The LEDs "CH.1" and "CH.2" are lit.
 - A high signal is present at the semiconductor output switch state Y32.
- ▶ Functional procedure once the input circuit is opened (e.g. safety contacts on the base unit are opened):
 - Safety contacts 13-14, 23-24, 33-34, 43-44 and 53-54 are opened redundantly.
 - The LEDs "CH.1" and "CH.2" go out.
 - A low signal is present at the semiconductor output switch state Y32.

Semiconductor output supply voltage Y35

- ▶ A high signal is present at semi-conductor output Y35 if the supply voltage is present and the internal fuse has not blown.

Installation

- ▶ The unit should be installed in a control cabinet with a protection type of at least IP54.
- ▶ Use the notch on the rear of the unit to attach it to a DIN rail.
- ▶ Ensure the unit is mounted securely on a vertical DIN rail (35 mm) by using a fixing element (e.g. retaining bracket or an end angle).

Wiring

Please note:

- ▶ Information given in the "[Technical details \[475\]](#)" must be followed.
- ▶ The outputs 13-14, 23-24, 33-34, 43-44, 53-54 are safety contacts.
- ▶ To prevent contact welding, a fuse should be connected before the output contacts (see [Technical details \[475\]](#)).
- ▶ Calculation of the max. cable length l_{\max} in the input circuit:

$$l_{\max} = \frac{R_{l_{\max}}}{R_1 / \text{km}}$$

$R_{l_{\max}}$ = max. overall cable resistance (see [Technical details \[475\]](#))

R_1 / km = cable resistance/km

- ▶ Use copper wire that can withstand 60/75 °C.

Safety relays PNOZ X PZE X5P

- ▶ Sufficient fuse protection must be provided on all output contacts with capacitive and inductive loads.
- ▶ Do not switch low currents using contacts that have been used previously with high currents.
- ▶ The power supply must comply with the regulations for extra low voltages with protective electrical separation (SELV, PELV) in accordance with VDE 0100, Part 410.
- ▶ Ensure the wiring and EMC requirements of IEC 60204-1 are met.

Preparing for operation

| Supply voltage | AC | DC |
|--|----------------|--------------|
| | | |
| Input circuit | Single-channel | Dual-channel |
| E-STOP without detection of shorts across contacts | | |
| E-STOP with detection of shorts across contacts | | |
| Feedback loop | | |
| Y1 and Y2 are feedback loop inputs on the base unit | | |
| Semiconductor output | | |
| Y31, Y30: External supply voltage | | |

Safety relays PNOZ X PZE X5P

Dimensions in mm

* with spring-loaded terminals

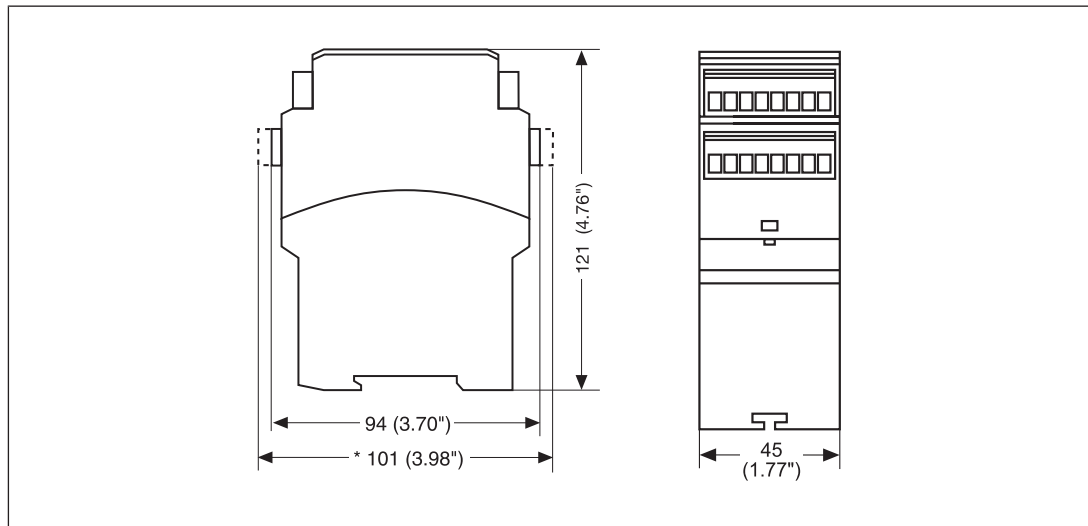

Technical details

| General | 777150 | 787150 |
|--------------------------------------|--|--|
| Approvals | CCC, CE, EAC (Eurasian), TÜV, cULus Listed | CCC, CE, EAC (Eurasian), TÜV, cULus Listed |
| Electrical data | 777150 | 787150 |
| Supply voltage | | |
| Voltage | 24 V | 24 V |
| Kind | DC | DC |
| Voltage tolerance | -15 %/+10 % | -15 %/+10 % |
| Output of external power supply (DC) | 3,5 W | 3,5 W |
| Residual ripple DC | 20 % | 20 % |
| Duty cycle | 100 % | 100 % |
| Max. inrush current impulse | | |
| Current pulse, A1 | 10 A | 10 A |
| Pulse duration, A1 | 0,5 ms | 0,5 ms |
| Inputs | 777150 | 787150 |
| Number | 2 | 2 |
| Voltage at | | |
| Input circuit DC | 24 V | 24 V |
| Current at | | |
| Input circuit DC | 40 mA | 40 mA |

Safety relays PNOZ X PZE X5P

| Inputs | 777150 | 787150 |
|---|--------------|--------------|
| Max. overall cable resistance RI-max | | |
| Single-channel at UB DC | 120 Ohm | 120 Ohm |
| Dual-channel without detection of shorts across contacts at UB DC | 240 Ohm | 240 Ohm |
| Dual-channel with detection of shorts across contacts at UB DC | 4 Ohm | 4 Ohm |
| Semiconductor outputs | 777150 | 787150 |
| Number | 2 | 2 |
| Voltage | 24 V | 24 V |
| Current | 20 mA | 20 mA |
| External supply voltage | 24 V | 24 V |
| Voltage tolerance | -20 %/+20 % | -20 %/+20 % |
| Relay outputs | 777150 | 787150 |
| Number of output contacts | | |
| Safety contacts (N/O), instantaneous | 5 | 5 |
| Max. short circuit current IK | 1 kA | 1 kA |
| Utilisation category | | |
| In accordance with the standard | EN 60947-4-1 | EN 60947-4-1 |
| Utilisation category of safety contacts | | |
| AC1 at | 240 V | 240 V |
| Min. current | 0,01 A | 0,01 A |
| Max. current | 8 A | 8 A |
| Max. power | 2000 VA | 2000 VA |
| DC1 at | 24 V | 24 V |
| Min. current | 0,01 A | 0,01 A |
| Max. current | 8 A | 8 A |
| Max. power | 200 W | 200 W |
| Utilisation category | | |
| In accordance with the standard | EN 60947-5-1 | EN 60947-5-1 |
| Utilisation category of safety contacts | | |
| AC15 at | 230 V | 230 V |
| Max. current | 5 A | 5 A |
| DC13 (6 cycles/min) at | 24 V | 24 V |
| Max. current | 7 A | 7 A |

Safety relays PNOZ X PZE X5P

| Relay outputs | 777150 | 787150 |
|--|--------------------------------|--------------------------------|
| Utilisation category in accordance with UL | | |
| Voltage | 240 V AC G. P. | 240 V AC G. P. |
| With current | 8 A | 8 A |
| Voltage | 24 V DC G. P. Resistive | 24 V DC G. P. Resistive |
| With current | 5 A | 5 A |
| Pilot Duty | B300, R300 | B300, R300 |
| External contact fuse protection, safety contacts | | |
| In accordance with the standard | EN 60947-5-1 | EN 60947-5-1 |
| Max. melting integral | 240 A ² s | 240 A ² s |
| Blow-out fuse, quick | 10 A | 10 A |
| Blow-out fuse, slow | 6 A | 6 A |
| Blow-out fuse, gG | 10 A | 10 A |
| Circuit breaker 24V AC/DC, characteristic B/C | 6 A | 6 A |
| Contact material | AgSnO ₂ + 0,2 µm Au | AgSnO ₂ + 0,2 µm Au |
| Conventional thermal current while loading several contacts | 777150 | 787150 |
| I _{th} per contact at UB DC; AC1: 240 V, DC1: 24 V | | |
| Conv. therm. current with 1 contact | 8 A | 8 A |
| Conv. therm. current with 2 contacts | 8 A | 8 A |
| Conv. therm. current with 3 contacts | 6,5 A | 6,5 A |
| Conv. therm. current with 4 contacts | 5,6 A | 5,6 A |
| Conv. therm. current with 5 contacts | 5 A | 5 A |
| Times | 777150 | 787150 |
| Switch-on delay | | |
| With automatic start typ. | 15 ms | 15 ms |
| With automatic start max. | 30 ms | 30 ms |
| With automatic start after power on typ. | 15 ms | 15 ms |
| With automatic start after power on max. | 30 ms | 30 ms |

Safety relays PNOZ X PZE X5P

| Times | 777150 | 787150 |
|---|--|--|
| Delay-on de-energisation | | |
| With E-STOP typ. | 15 ms | 15 ms |
| With E-STOP max. | 30 ms | 30 ms |
| With power failure typ. | 110 ms | 110 ms |
| With power failure max. | 150 ms | 150 ms |
| Supply interruption before de-energisation in the input circuit | 8 ms | 8 ms |
| Supply interruption before de-energisation | 20 ms | 20 ms |
| Environmental data | 777150 | 787150 |
| Climatic suitability | EN 60068-2-78 | EN 60068-2-78 |
| Ambient temperature | | |
| Temperature range | -10 - 55 °C | -10 - 55 °C |
| Storage temperature | | |
| Temperature range | -40 - 85 °C | -40 - 85 °C |
| Climatic suitability | | |
| Humidity | 93 % r. h. at 40 °C | 93 % r. h. at 40 °C |
| Condensation during operation | Not permitted | Not permitted |
| EMC | EN 60947-5-1, EN 61000-6-2, EN 61326-3-1 | EN 60947-5-1, EN 61000-6-2, EN 61326-3-1 |
| Vibration | | |
| In accordance with the standard | EN 60068-2-6 | EN 60068-2-6 |
| Frequency | 10 - 55 Hz | 10 - 55 Hz |
| Amplitude | 0,35 mm | 0,35 mm |
| Airgap creepage | | |
| In accordance with the standard | EN 60947-1 | EN 60947-1 |
| Overvoltage category | III / II | III / II |
| Pollution degree | 2 | 2 |
| Rated insulation voltage | 250 V | 250 V |
| Rated impulse withstand voltage | 4 kV | 4 kV |
| Protection type | | |
| Mounting area (e.g. control cabinet) | IP54 | IP54 |
| Housing | IP40 | IP40 |
| Terminals | IP20 | IP20 |
| Mechanical data | 777150 | 787150 |
| Mounting position | Any | Any |
| Mechanical life | 10,000,000 cycles | 10,000,000 cycles |

Safety relays PNOZ X PZE X5P

| Mechanical data | 777150 | 787150 |
|---|---|--|
| Material | | |
| Bottom | PPO UL 94 V0 | PPO UL 94 V0 |
| Front | ABS UL 94 V0 | ABS UL 94 V0 |
| Top | PPO UL 94 V0 | PPO UL 94 V0 |
| Connection type | Screw terminal | Spring-loaded terminal |
| Mounting type | plug-in | plug-in |
| Conductor cross section with screw terminals | | |
| 1 core flexible | 0,25 - 2,5 mm², 24 - 12 AWG | – |
| 2 core with the same cross section, flexible with crimp connectors, no plastic sleeve | 0,25 - 1 mm², 24 - 16 AWG | – |
| 2 core with the same cross section, flexible without crimp connectors or with TWIN crimp connectors | 0,2 - 1,5 mm², 24 - 16 AWG | – |
| Torque setting with screw terminals | 0,5 Nm | – |
| Conductor cross section with spring-loaded terminals: Flexible with/without crimp connector | – | 0,2 - 1,5 mm², 24 - 16 AWG |
| Spring-loaded terminals: Terminal points per connection | – | 2 |
| Stripping length with spring-loaded terminals | – | 8 mm |
| Dimensions | | |
| Height | 94 mm | 101 mm |
| Width | 45 mm | 45 mm |
| Depth | 121 mm | 121 mm |
| Weight | 260 g | 260 g |

Where standards are undated, the 2014-07 latest editions shall apply.

Safety characteristic data

| Operating Mode | EN ISO 13849-1: 2015 | EN ISO 13849-1: 2015 | EN 62061 SIL CL | EN 62061 PFH _D [1/h] | IEC 61511 SIL | IEC 61511 PFD | EN ISO 13849-1: 2015 T _M [year] |
|----------------|----------------------|----------------------|-----------------|---------------------------------|---------------|-----------------|--|
| – | PL e | Cat. 4 | SIL CL 3 | 2,31E-09 | SIL 3 | 2,03E-06 | 20 |

All the units used within a safety function must be considered when calculating the safety characteristic data.

Safety relays PNOZ X PZE X5P

Supplementary data

The PFH value depends on the switching frequency and the load on the relay output. If the service life graphs are not accessible, the stated PFH value can be used irrespective of the switching frequency and the load, as the PFH value already considers the relay's B10d value as well as the failure rates of the other components.

Service life graph

The service life graphs indicate the number of cycles from which failures due to wear must be expected. The wear is mainly caused by the electrical load; the mechanical load is negligible.

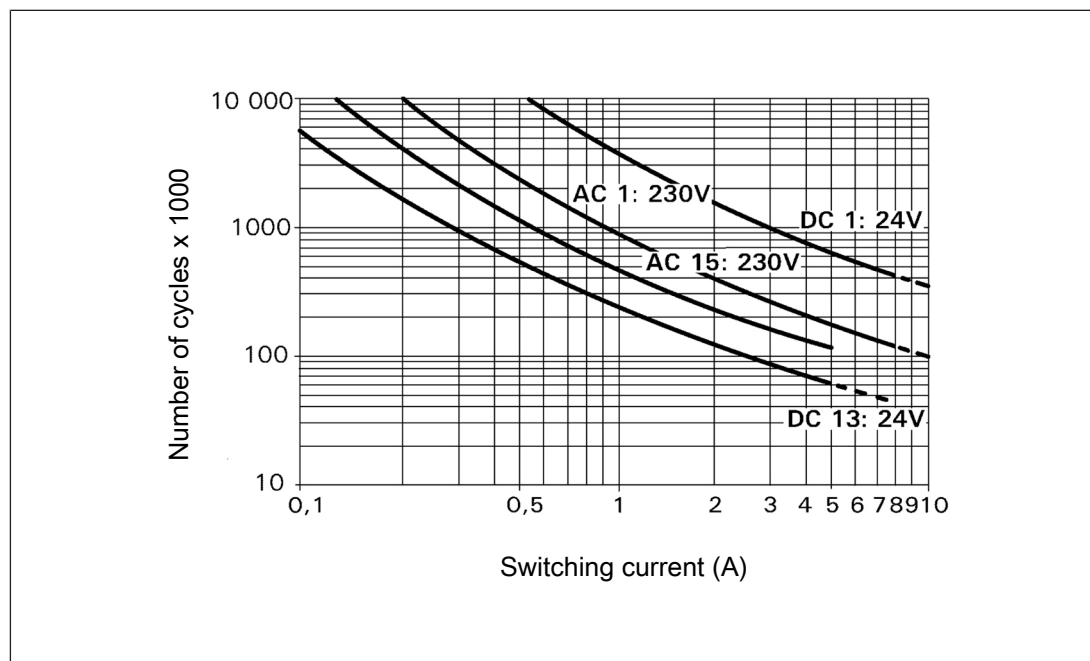

Example

- ▶ Inductive load: 0.2 A
- ▶ Utilisation category: AC15
- ▶ Contact service life: 4 000 000 cycles

Provided the application to be implemented requires fewer than 4 000 000 cycles, the PFH value (see Technical details) can be used in the calculation.

To increase the service life, sufficient spark suppression must be provided on all output contacts. With capacitive loads, any power surges that occur must be noted. With DC contactors, use flywheel diodes for spark suppression.

Safety relays PNOZ X PZE X5P

Order reference

| Type | Features | Terminals | Order no. |
|-----------|----------|-------------------------|-----------|
| PZE X5P C | 24 V DC | Spring-loaded terminals | 787 150 |
| PZE X5P | 24 V DC | Screw terminals | 777 150 |

Safety relays PNOZ X PZE 9P

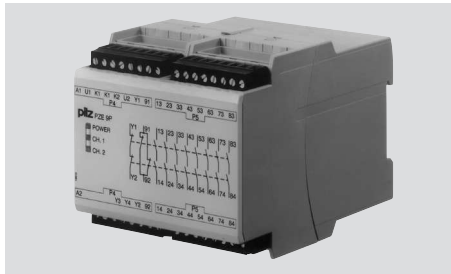

Unit features

- ▶ Positive-guided relay outputs:
 - 8 safety contacts (N/O), instantaneous
 - 1 auxiliary contact (N/C), instantaneous
- ▶ LED display for:
 - Supply voltage
 - Switch status of the safety contacts
- ▶ Connection for feedback loop
- ▶ Operation: Single or dual-channel
- ▶ Plug-in connection terminals (either spring-loaded terminal or screw terminal)
- ▶ See order reference for unit types

Block diagram/terminal configuration

Type: 24 V AC/DC

- ▶ U_B : 24 VAC/DC; Order no. 777140, 787140

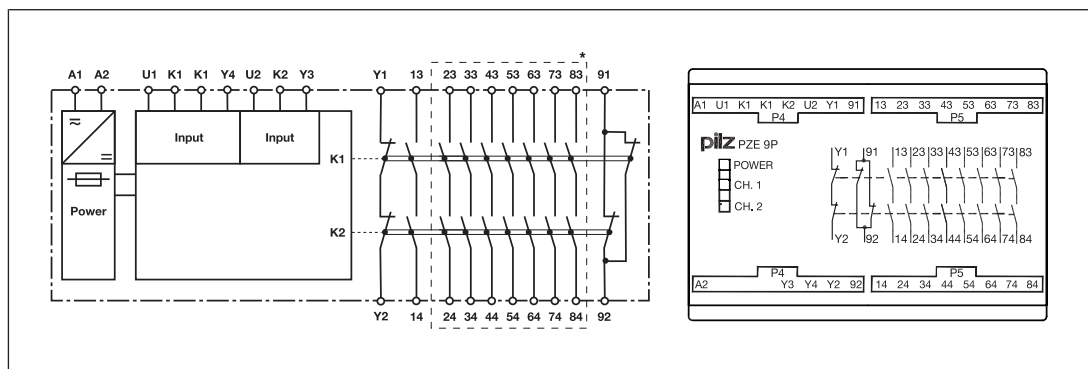

*Safe separation from non-marked area, except for safety contact 13-14, in accordance with EN 60947-1, 6 kV, basic insulation between all safety contacts.

Safety relays PNOZ X PZE 9P

Type: 24 - 240 V AC/DC

- ▶ U_B : 24 - 240 VAC/DC, 24 VAC/DC; Order no. 777148, 787148

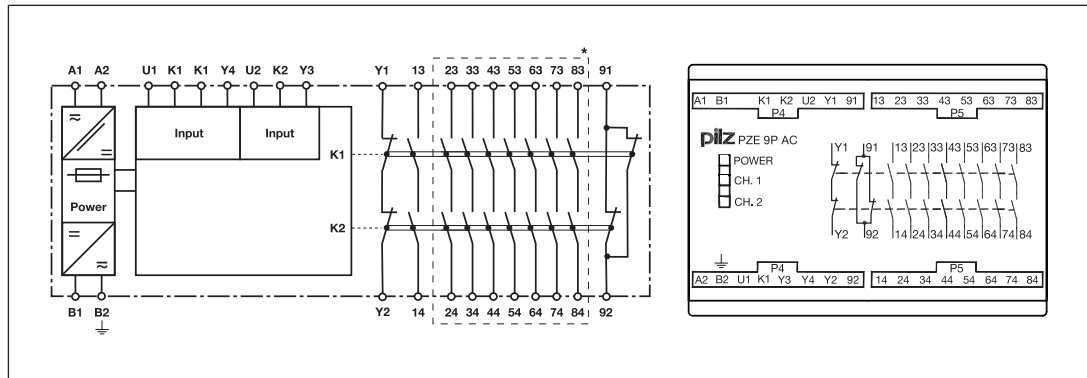

*Safe separation from non-marked area, except for safety contact 13-14, in accordance with EN 60947-1, 6 kV, basic insulation between all safety contacts.

Function description

The contact expansion module PZE 9P is an add-on device without delay-on de-energisation. It is used to expand a safety circuit. The contact expansion module is driven by a base unit (e. g. emergency stop relay). When operating voltage is supplied the "POWER" LED will light.

- ▶ Functional procedure once the input circuit is closed (e.g. safety contacts on the base unit are closed):
 - Safety contacts 13-14, 23-24, 33-34, 43-44, 53-54, 63-64, 73-74 and 83-84 close, auxiliary contact 91-92 opens.
 - The LEDs "CH.1" and "CH.2" are lit.
- ▶ Functional procedure once the input circuit is opened (e.g. safety contacts on the base unit are opened):
 - Safety contacts 13-14, 23-24, 33-34, 43-44, 53-54, 63-64, 73-74 and 83-84 are opened redundantly, auxiliary contact 91-92 is closed.
 - The LEDs "CH.1" and "CH.2" go out.

Installation

- ▶ The unit should be installed in a control cabinet with a protection type of at least IP54.
- ▶ Use the notch on the rear of the unit to attach it to a DIN rail.
- ▶ Ensure the unit is mounted securely on a vertical DIN rail (35 mm) by using a fixing element (e.g. retaining bracket or an end angle).

Safety relays PNOZ X PZE 9P

Wiring

Please note:

- ▶ Information given in the "[Technical details \[486\]](#)" must be followed.
- ▶ Outputs 13-14, 23-24, 33-34, 43-44, 53-54, 63-64, 73-74, 83-84 are safety contacts; output 91-92 is an auxiliary contact (e.g. for display).
- ▶ Do **not** use auxiliary contact 91-92 for safety circuits!
- ▶ Do not connect undesignated terminals.
- ▶ To prevent contact welding, a fuse should be connected before the output contacts (see [Technical details \[486\]](#)).
- ▶ Calculation of the max. cable length l_{\max} in the input circuit:

$$l_{\max} = \frac{R_{l_{\max}}}{R_l / \text{km}}$$

$R_{l_{\max}}$ = max. overall cable resistance (see [Technical details \[486\]](#))

R_l / km = cable resistance/km

- ▶ Use copper wire that can withstand 60/75 °C.
- ▶ Sufficient fuse protection must be provided on all output contacts with capacitive and inductive loads.
- ▶ Do not switch low currents using contacts that have been used previously with high currents.
- ▶ 777140, 787140 units or 777148, 787148 units, when the supply voltage is connected via B1 and B2: The power supply must comply with the regulations for extra low voltages with safe electrical separation (SELV, PELV) in accordance with VDE 0100, Part 410.
- ▶ Ensure the wiring and EMC requirements of IEC 60204-1 are met.

Safety relays PNOZ X PZE 9P

Preparing for operation

| Supply voltage | 24 - 240 V AC/DC | 24 VAC/DC |
|---|--------------------------------|---------------------------------------|
| Order no.: 777148, 787148 | | |
| Order no.: 777140, 787140 | | |
| Input circuit | Single-channel | Dual-channel |
| without detection of shorts across contacts Base unit: Safety relay PNOZ X Driven via safety contacts | | |
| with detection of shorts across contacts Base unit: Safety relay PNOZ X Driven via safety contacts | | |
| without detection of shorts across contacts Base unit: Safety system or PNOZmulti Driven via safe semiconductor outputs (24 VDC) | | |
| Feedback loop | Base unit: Safety relay PNOZ X | Base unit: Safety system or PNOZmulti |
| Y1, Y2 and Input are inputs on the base unit; they evaluate the feedback loop | | |

Safety relays PNOZ X PZE 9P

Dimensions in mm

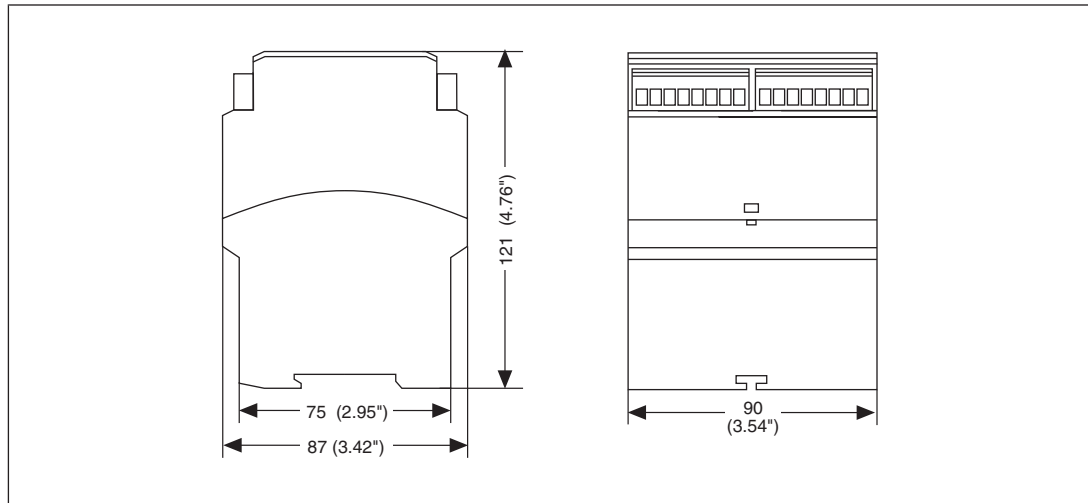

Technical details

Order no. 777140 – 787140

See below for more order numbers

| General | 777140 | 787140 |
|--------------------------------------|--|--|
| Approvals | CCC, CE, EAC (Eurasian), TÜV, cULus Listed | CCC, CE, EAC (Eurasian), TÜV, cULus Listed |
| Electrical data | 777140 | 787140 |
| Supply voltage | | |
| Voltage | 24 V | 24 V |
| Kind | AC/DC | AC/DC |
| Voltage tolerance | -15 %/+10 % | -15 %/+10 % |
| Output of external power supply (AC) | 9,5 VA | 9,5 VA |
| Output of external power supply (DC) | 3,5 W | 3,5 W |
| Frequency range AC | 50 - 60 Hz | 50 - 60 Hz |
| Residual ripple DC | 160 % | 160 % |
| Duty cycle | 100 % | 100 % |
| Inputs | 777140 | 787140 |
| Number | 2 | 2 |
| Voltage at | | |
| Input circuit DC | 24 V | 24 V |
| Current at | | |
| Input circuit DC | 40 mA | 40 mA |

Safety relays PNOZ X PZE 9P

| Inputs | 777140 | 787140 |
|---|--------------|--------------|
| Max. overall cable resistance RI-max | | |
| Single-channel at UB DC | 50 Ohm | 50 Ohm |
| Single-channel at UB AC | 80 Ohm | 80 Ohm |
| Dual-channel without detection of shorts across contacts at UB DC | 100 Ohm | 100 Ohm |
| Dual-channel without detection of shorts across contacts at UB AC | 160 Ohm | 160 Ohm |
| Dual-channel with detection of shorts across contacts at UB DC | 5 Ohm | 5 Ohm |
| Dual-channel with detection of shorts across contacts at UB AC | 10 Ohm | 10 Ohm |
| Relay outputs | 777140 | 787140 |
| Number of output contacts | | |
| Safety contacts (N/O), instantaneous | 8 | 8 |
| Auxiliary contacts (N/C) | 1 | 1 |
| Max. short circuit current IK | 1 kA | 1 kA |
| Utilisation category | | |
| In accordance with the standard | EN 60947-4-1 | EN 60947-4-1 |
| Utilisation category of safety contacts | | |
| AC1 at | 240 V | 240 V |
| Min. current | 0,01 A | 0,01 A |
| Max. current | 8 A | 8 A |
| Max. power | 2000 VA | 2000 VA |
| DC1 at | 24 V | 24 V |
| Min. current | 0,01 A | 0,01 A |
| Max. current | 8 A | 8 A |
| Max. power | 200 W | 200 W |
| Utilisation category of auxiliary contacts | | |
| AC1 at | 240 V | 240 V |
| Min. current | 0,01 A | 0,01 A |
| Max. current | 2 A | 2 A |
| Max. power | 500 VA | 500 VA |
| DC1 at | 24 V | 24 V |
| Min. current | 0,01 A | 0,01 A |
| Max. current | 2 A | 2 A |
| Max. power | 50 W | 50 W |

Safety relays PNOZ X PZE 9P

| Relay outputs | 777140 | 787140 |
|--|--------------------------------------|--------------------------------------|
| Utilisation category | | |
| In accordance with the standard | EN 60947-5-1 | EN 60947-5-1 |
| Utilisation category of safety contacts | | |
| AC15 at | 230 V | 230 V |
| Max. current | 5 A | 5 A |
| DC13 (6 cycles/min) at | 24 V | 24 V |
| Max. current | 7 A | 7 A |
| Utilisation category of auxiliary contacts | | |
| AC15 at | 230 V | 230 V |
| Max. current | 2 A | 2 A |
| DC13 (6 cycles/min) at | 24 V | 24 V |
| Max. current | 2 A | 2 A |
| Utilisation category in accordance with UL | | |
| Voltage | 240 V AC G. P. | 240 V AC G. P. |
| With current | 8 A | 8 A |
| Voltage | 24 V DC G. P. Resistive | 24 V DC G. P. Resistive |
| With current | 5 A | 5 A |
| Pilot Duty | B300, R300 | B300, R300 |
| External contact fuse protection, safety contacts | | |
| In accordance with the standard | EN 60947-5-1 | EN 60947-5-1 |
| Max. melting integral | 240 A²s | 240 A²s |
| Blow-out fuse, quick | 10 A | 10 A |
| Blow-out fuse, slow | 6 A | 6 A |
| Blow-out fuse, gG | 10 A | 10 A |
| Circuit breaker 24V AC/DC, characteristic B/C | 6 A | 6 A |
| External contact fuse protection, auxiliary contacts | | |
| Max. melting integral | 240 A²s | 240 A²s |
| Blow-out fuse, quick | 4 A | 4 A |
| Blow-out fuse, slow | 2 A | 2 A |
| Blow-out fuse, gG | 4 A | 4 A |
| Circuit breaker 24 V AC/DC, characteristic B/C | 2 A | 2 A |
| Contact material | AgSnO₂ + 0,2 µm Au | AgSnO₂ + 0,2 µm Au |

Safety relays PNOZ X PZE 9P

| Conventional thermal current while loading several contacts | 777140 | 787140 |
|--|--------|--------|
| I _{th} per contact at UB AC; AC1: 240 V, DC1: 24 V | | |
| Conv. therm. current with 1 contact | 8 A | 8 A |
| Conv. therm. current with 2 contacts | 8 A | 8 A |
| Conv. therm. current with 3 contacts | 8 A | 8 A |
| Conv. therm. current with 4 contacts | 7,1 A | 7,1 A |
| Conv. therm. current with 5 contacts | 6,3 A | 6,3 A |
| Conv. therm. current with 6 contacts | 5,8 A | 5,8 A |
| Conv. therm. current with 7 contacts | 5,4 A | 5,4 A |
| Conv. therm. current with 8 contacts | 5 A | 5 A |
| I _{th} per contact at UB DC; AC1: 240 V, DC1: 24 V | | |
| Conv. therm. current with 1 contact | 8 A | 8 A |
| Conv. therm. current with 2 contacts | 8 A | 8 A |
| Conv. therm. current with 3 contacts | 8 A | 8 A |
| Conv. therm. current with 4 contacts | 7,1 A | 7,1 A |
| Conv. therm. current with 5 contacts | 6,3 A | 6,3 A |
| Conv. therm. current with 6 contacts | 5,8 A | 5,8 A |
| Conv. therm. current with 7 contacts | 5,4 A | 5,4 A |
| Conv. therm. current with 8 contacts | 5 A | 5 A |
| Times | 777140 | 787140 |
| Switch-on delay | | |
| With automatic start typ. | 30 ms | 30 ms |
| With automatic start max. | 40 ms | 40 ms |
| With automatic start after power on typ. | 30 ms | 30 ms |
| With automatic start after power on max. | 40 ms | 40 ms |

Safety relays PNOZ X PZE 9P

| Times | 777140 | 787140 |
|---|---|---|
| Delay-on de-energisation | | |
| With E-STOP typ. | 20 ms | 20 ms |
| With E-STOP max. | 30 ms | 30 ms |
| With power failure typ. | 110 ms | 110 ms |
| With power failure max. | 200 ms | 200 ms |
| Supply interruption before de-energisation in the input circuit | 10 ms | 10 ms |
| Supply interruption before de-energisation | 20 ms | 20 ms |
| Environmental data | 777140 | 787140 |
| Climatic suitability | EN 60068-2-78 | EN 60068-2-78 |
| Ambient temperature | | |
| Temperature range | -10 - 55 °C | -10 - 55 °C |
| Storage temperature | | |
| Temperature range | -40 - 85 °C | -40 - 85 °C |
| Climatic suitability | | |
| Humidity | 93 % r. h. at 40 °C | 93 % r. h. at 40 °C |
| Condensation during operation | Not permitted | Not permitted |
| EMC | EN 60947-5-1, EN 61000-6-2, EN 61326-3-1 | EN 60947-5-1, EN 61000-6-2, EN 61326-3-1 |
| Vibration | | |
| In accordance with the standard | EN 60068-2-6 | EN 60068-2-6 |
| Frequency | 10 - 55 Hz | 10 - 55 Hz |
| Amplitude | 0,35 mm | 0,35 mm |
| Airgap creepage | | |
| In accordance with the standard | EN 60947-1 | EN 60947-1 |
| Overvoltage category | III | III |
| Pollution degree | 2 | 2 |
| Rated insulation voltage | 250 V | 250 V |
| Rated impulse withstand voltage | 6 kV | 6 kV |
| Protection type | | |
| Mounting area (e.g. control cabinet) | IP54 | IP54 |
| Housing | IP40 | IP40 |
| Terminals | IP20 | IP20 |
| Mechanical data | 777140 | 787140 |
| Mounting position | Any | Any |
| Mechanical life | 10,000,000 cycles | 10,000,000 cycles |

Safety relays PNOZ X PZE 9P

| Mechanical data | 777140 | 787140 |
|---|---|--|
| Material | | |
| Bottom | PPO UL 94 V0 | PPO UL 94 V0 |
| Front | ABS UL 94 V0 | ABS UL 94 V0 |
| Top | PPO UL 94 V0 | PPO UL 94 V0 |
| Connection type | Screw terminal | Spring-loaded terminal |
| Mounting type | plug-in | plug-in |
| Conductor cross section with screw terminals | | |
| 1 core flexible | 0,25 - 2,5 mm², 24 - 12 AWG | – |
| 2 core with the same cross section, flexible with crimp connectors, no plastic sleeve | 0,25 - 1 mm², 24 - 16 AWG | – |
| 2 core with the same cross section, flexible without crimp connectors or with TWIN crimp connectors | 0,2 - 1,5 mm², 24 - 16 AWG | – |
| Torque setting with screw terminals | 0,5 Nm | – |
| Conductor cross section with spring-loaded terminals: Flexible with/without crimp connector | – | 0,2 - 1,5 mm², 24 - 16 AWG |
| Spring-loaded terminals: Terminal points per connection | – | 2 |
| Stripping length with spring-loaded terminals | – | 8 mm |
| Dimensions | | |
| Height | 87 mm | 87 mm |
| Width | 90 mm | 90 mm |
| Depth | 121 mm | 121 mm |
| Weight | 430 g | 430 g |

Where standards are undated, the 2014-07 latest editions shall apply.

Safety relays PNOZ X PZE 9P

Order no. 777148 – 787148

| General | 777148 | 787148 |
|--------------------------------------|--|--|
| Approvals | CCC, CE, EAC (Eurasian), TÜV, cULus Listed | CCC, CE, EAC (Eurasian), TÜV, cULus Listed |
| Electrical data | 777148 | 787148 |
| Supply voltage | | |
| Voltage | 24 - 240 V | 24 - 240 V |
| Kind | AC/DC | AC/DC |
| Voltage tolerance | -15 %/+10 % | -15 %/+10 % |
| Output of external power supply (AC) | 9,5 VA | 9,5 VA |
| Output of external power supply (DC) | 6 W | 6 W |
| Frequency range AC | 50 - 60 Hz | 50 - 60 Hz |
| Residual ripple DC | 160 % | 160 % |
| Supply voltage | | |
| Voltage | 24 V | 24 V |
| Kind | AC/DC | AC/DC |
| Voltage tolerance | -15 %/+10 % | -15 %/+10 % |
| Output of external power supply (AC) | 9,5 VA | 9,5 VA |
| Output of external power supply (DC) | 3,5 W | 3,5 W |
| Frequency range AC | 50 - 60 Hz | 50 - 60 Hz |
| Residual ripple DC | 160 % | 160 % |
| Duty cycle | 100 % | 100 % |
| Inputs | 777148 | 787148 |
| Number | 2 | 2 |
| Voltage at | | |
| Input circuit DC | 24 V | 24 V |
| Current at | | |
| Input circuit DC | 40 mA | 40 mA |

Safety relays PNOZ X PZE 9P

| Inputs | 777148 | 787148 |
|---|--------------|--------------|
| Max. overall cable resistance RI-max | | |
| Single-channel at UB DC | 50 Ohm | 50 Ohm |
| Single-channel at UB AC | 80 Ohm | 80 Ohm |
| Dual-channel without detection of shorts across contacts at UB DC | 100 Ohm | 100 Ohm |
| Dual-channel without detection of shorts across contacts at UB AC | 160 Ohm | 160 Ohm |
| Dual-channel with detection of shorts across contacts at UB DC | 3 Ohm | 3 Ohm |
| Dual-channel with detection of shorts across contacts at UB AC | 8 Ohm | 8 Ohm |
| Relay outputs | 777148 | 787148 |
| Number of output contacts | | |
| Safety contacts (N/O), instantaneous | 8 | 8 |
| Auxiliary contacts (N/C) | 1 | 1 |
| Max. short circuit current IK | 1 kA | 1 kA |
| Utilisation category | | |
| In accordance with the standard | EN 60947-4-1 | EN 60947-4-1 |
| Utilisation category of safety contacts | | |
| AC1 at | 240 V | 240 V |
| Min. current | 0,01 A | 0,01 A |
| Max. current | 8 A | 8 A |
| Max. power | 2000 VA | 2000 VA |
| DC1 at | 24 V | 24 V |
| Min. current | 0,01 A | 0,01 A |
| Max. current | 8 A | 8 A |
| Max. power | 200 W | 200 W |
| Utilisation category of auxiliary contacts | | |
| AC1 at | 240 V | 240 V |
| Min. current | 0,01 A | 0,01 A |
| Max. current | 2 A | 2 A |
| Max. power | 500 VA | 500 VA |
| DC1 at | 24 V | 24 V |
| Min. current | 0,01 A | 0,01 A |
| Max. current | 2 A | 2 A |
| Max. power | 50 W | 50 W |

Safety relays PNOZ X PZE 9P

| Relay outputs | 777148 | 787148 |
|--|--------------------------------------|--------------------------------------|
| Utilisation category | | |
| In accordance with the standard | EN 60947-5-1 | EN 60947-5-1 |
| Utilisation category of safety contacts | | |
| AC15 at | 230 V | 230 V |
| Max. current | 5 A | 5 A |
| DC13 (6 cycles/min) at | 24 V | 24 V |
| Max. current | 7 A | 7 A |
| Utilisation category of auxiliary contacts | | |
| AC15 at | 230 V | 230 V |
| Max. current | 2 A | 2 A |
| DC13 (6 cycles/min) at | 24 V | 24 V |
| Max. current | 2 A | 2 A |
| Utilisation category in accordance with UL | | |
| Voltage | 240 V AC G. P. | 240 V AC G. P. |
| With current | 8 A | 8 A |
| Voltage | 24 V DC G. P. Resistive | 24 V DC G. P. Resistive |
| With current | 5 A | 5 A |
| Pilot Duty | B300, R300 | B300, R300 |
| External contact fuse protection, safety contacts | | |
| In accordance with the standard | EN 60947-5-1 | EN 60947-5-1 |
| Max. melting integral | 240 A²s | 240 A²s |
| Blow-out fuse, quick | 10 A | 10 A |
| Blow-out fuse, slow | 6 A | 6 A |
| Blow-out fuse, gG | 10 A | 10 A |
| Circuit breaker 24V AC/DC, characteristic B/C | 6 A | 6 A |
| External contact fuse protection, auxiliary contacts | | |
| Max. melting integral | 240 A²s | 240 A²s |
| Blow-out fuse, quick | 4 A | 4 A |
| Blow-out fuse, slow | 2 A | 2 A |
| Blow-out fuse, gG | 4 A | 4 A |
| Circuit breaker 24 V AC/DC, characteristic B/C | 2 A | 2 A |
| Contact material | AgSnO₂ + 0,2 µm Au | AgSnO₂ + 0,2 µm Au |

Safety relays PNOZ X PZE 9P

| Conventional thermal current while loading several contacts | 777148 | 787148 |
|--|---------------|---------------|
| I _{th} per contact at UB AC; AC1: 240 V, DC1: 24 V | | |
| Conv. therm. current with 1 contact | 8 A | 8 A |
| Conv. therm. current with 2 contacts | 8 A | 8 A |
| Conv. therm. current with 3 contacts | 8 A | 8 A |
| Conv. therm. current with 4 contacts | 7,1 A | 7,1 A |
| Conv. therm. current with 5 contacts | 6,3 A | 6,3 A |
| Conv. therm. current with 6 contacts | 5,8 A | 5,8 A |
| Conv. therm. current with 7 contacts | 5,4 A | 5,4 A |
| Conv. therm. current with 8 contacts | 5 A | 5 A |
| I _{th} per contact at UB DC; AC1: 240 V, DC1: 24 V | | |
| Conv. therm. current with 1 contact | 8 A | 8 A |
| Conv. therm. current with 2 contacts | 8 A | 8 A |
| Conv. therm. current with 3 contacts | 8 A | 8 A |
| Conv. therm. current with 4 contacts | 7,1 A | 7,1 A |
| Conv. therm. current with 5 contacts | 6,3 A | 6,3 A |
| Conv. therm. current with 6 contacts | 5,8 A | 5,8 A |
| Conv. therm. current with 7 contacts | 5,4 A | 5,4 A |
| Conv. therm. current with 8 contacts | 5 A | 5 A |
| Times | 777148 | 787148 |
| Switch-on delay | | |
| With automatic start typ. | 30 ms | 30 ms |
| With automatic start max. | 40 ms | 40 ms |
| With automatic start after power on typ. | 300 ms | 300 ms |
| With automatic start after power on max. | 350 ms | 350 ms |

Safety relays PNOZ X PZE 9P

| Times | 777148 | 787148 |
|---|--|--|
| Delay-on de-energisation | | |
| With E-STOP typ. | 20 ms | 20 ms |
| With E-STOP max. | 30 ms | 30 ms |
| With power failure typ. | 200 ms | 200 ms |
| With power failure max. | 310 ms | 310 ms |
| With power failure typ. UB 240 V | 500 ms | 500 ms |
| With power failure max. UB 240 V | 630 ms | 630 ms |
| With power failure typ. UB 24 V | 150 ms | 150 ms |
| With power failure max. UB 24 V | 200 ms | 200 ms |
| Supply interruption before de-energisation in the input circuit | | |
| | 10 ms | 10 ms |
| Supply interruption before de-energisation | | |
| | 20 ms | 20 ms |
| Environmental data | | |
| | 777148 | 787148 |
| Climatic suitability | | |
| | EN 60068-2-78 | EN 60068-2-78 |
| Ambient temperature | | |
| Temperature range | -10 - 55 °C | -10 - 55 °C |
| Storage temperature | | |
| Temperature range | -40 - 85 °C | -40 - 85 °C |
| Climatic suitability | | |
| Humidity | 93 % r. h. at 40 °C | 93 % r. h. at 40 °C |
| Condensation during operation | | |
| | Not permitted | Not permitted |
| EMC | | |
| | EN 60947-5-1, EN 61000-6-2, EN 61326-3-1 | EN 60947-5-1, EN 61000-6-2, EN 61326-3-1 |
| Vibration | | |
| In accordance with the standard | EN 60068-2-6 | EN 60068-2-6 |
| Frequency | 10 - 55 Hz | 10 - 55 Hz |
| Amplitude | 0,35 mm | 0,35 mm |
| Airgap creepage | | |
| In accordance with the standard | EN 60947-1 | EN 60947-1 |
| Overvoltage category | III | III |
| Pollution degree | 2 | 2 |
| Rated insulation voltage | | |
| | 250 V | 250 V |
| Rated impulse withstand voltage | | |
| | 6 kV | 6 kV |
| Protection type | | |
| Mounting area (e.g. control cabinet) | IP54 | IP54 |
| Housing | IP40 | IP40 |
| Terminals | IP20 | IP20 |
| Mechanical data | | |
| | 777148 | 787148 |
| Mounting position | | |
| | Any | Any |

Safety relays PNOZ X PZE 9P

| Mechanical data | 777148 | 787148 |
|---|--|---|
| Mechanical life | 10,000,000 cycles | 10,000,000 cycles |
| Material | | |
| Bottom | PPO UL 94 V0 | PPO UL 94 V0 |
| Front | ABS UL 94 V0 | ABS UL 94 V0 |
| Top | PPO UL 94 V0 | PPO UL 94 V0 |
| Connection type | Screw terminal | Spring-loaded terminal |
| Mounting type | plug-in | plug-in |
| Conductor cross section with screw terminals | | |
| 1 core flexible | 0,25 - 2,5 mm ² , 24 - 12 AWG | – |
| 2 core with the same cross section, flexible with crimp connectors, no plastic sleeve | 0,25 - 1 mm ² , 24 - 16 AWG | – |
| 2 core with the same cross section, flexible without crimp connectors or with TWIN crimp connectors | 0,2 - 1,5 mm ² , 24 - 16 AWG | – |
| Torque setting with screw terminals | 0,5 Nm | – |
| Conductor cross section with spring-loaded terminals: Flexible with/without crimp connector | – | 0,2 - 1,5 mm ² , 24 - 16 AWG |
| Spring-loaded terminals: Terminal points per connection | – | 2 |
| Stripping length with spring-loaded terminals | – | 8 mm |
| Dimensions | | |
| Height | 87 mm | 87 mm |
| Width | 90 mm | 90 mm |
| Depth | 121 mm | 121 mm |
| Weight | 455 g | 455 g |

Where standards are undated, the 2014-07 latest editions shall apply.

Safety relays PNOZ X PZE 9P

Safety characteristic data

| Operating Mode | EN ISO 13849-1: 2015 PL | EN ISO 13849-1: 2015 Category | EN 62061 SIL CL | EN 62061 PFH _D [1/h] | IEC 61511 SIL | IEC 61511 PFD | EN ISO 13849-1: 2015 T _M [year] |
|----------------|----------------------------|----------------------------------|--------------------|------------------------------------|------------------|------------------|---|
| – | PL e | Cat. 4 | SIL CL 3 | 2,31E-09 | SIL 3 | 2,03E-06 | 20 |

All the units used within a safety function must be considered when calculating the safety characteristic data.

Supplementary data

The PFH value depends on the switching frequency and the load on the relay output. If the service life graphs are not accessible, the stated PFH value can be used irrespective of the switching frequency and the load, as the PFH value already considers the relay's B10d value as well as the failure rates of the other components.

Safety relays PNOZ X PZE 9P

Service life graph

The service life graphs indicate the number of cycles from which failures due to wear must be expected. The wear is mainly caused by the electrical load; the mechanical load is negligible.

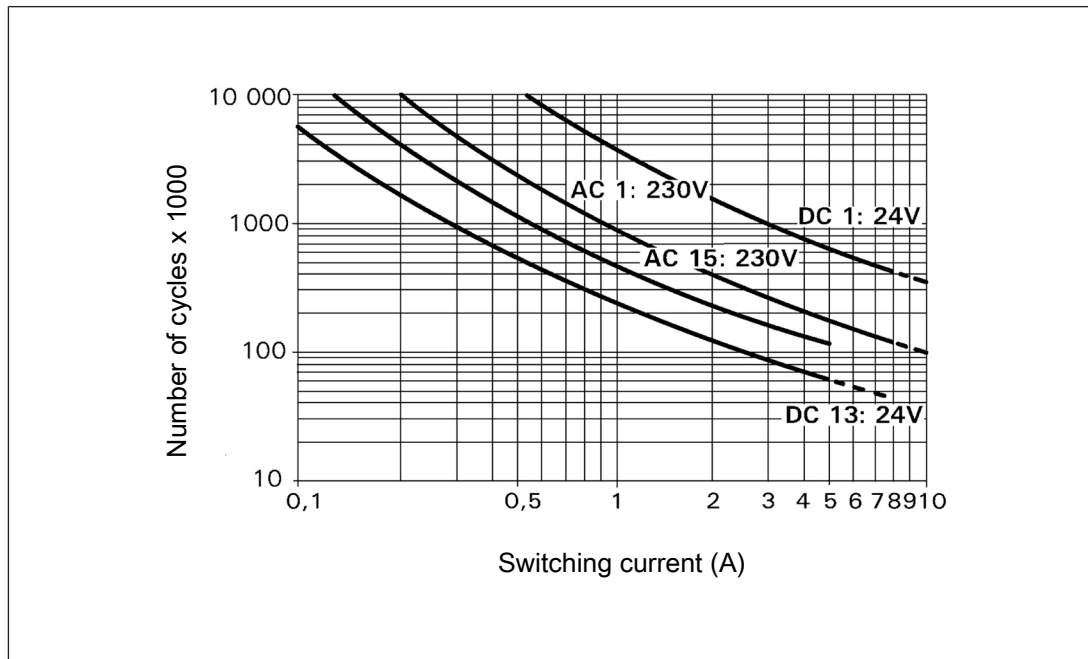

Example

- ▶ Inductive load: 0.2 A
- ▶ Utilisation category: AC15
- ▶ Contact service life: 4 000 000 cycles

Provided the application to be implemented requires fewer than 4 000 000 cycles, the PFH value (see Technical details) can be used in the calculation.

To increase the service life, sufficient spark suppression must be provided on all output contacts. With capacitive loads, any power surges that occur must be noted. With DC con-tactors, use flywheel diodes for spark suppression.

Order reference

| Type | Features | Connection type | Order no. |
|----------|---------------------------------|-------------------------|-----------|
| PZE 9P C | 24 V AC/DC | Spring-loaded terminals | 787 140 |
| PZE 9P | 24 V AC/DC | Screw terminals | 777 140 |
| PZE 9P C | 24 V AC/DC, 24 - 240 V AC/DC | Spring-loaded terminals | 787 148 |
| PZE 9P | 24 V AC/DC, 24 - 240 V AC/DC | Screw terminals | 777 148 |

Safety relays PNOZ X PMUT X1P

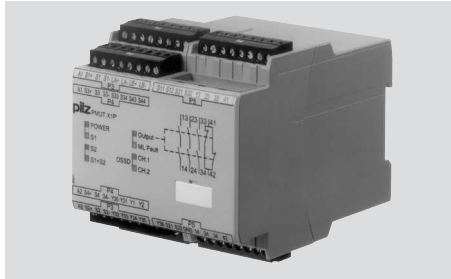

Unit features

- ▶ Positive-guided relay outputs:
 - 3 safety contacts (N/O), instantaneous
 - 1 auxiliary contact (N/C), instantaneous
- ▶ 4 inputs for muting sensors
- ▶ 1 ESPE input for light grids (2-channel, contact or semiconductor outputs)
- ▶ 1 input for additional safety light grid (2-channel, contact outputs) or safety contacts
- ▶ Connection option for 2 muting lamps
- ▶ Connection options for:
 - Start button
 - Key switch
 - Feedback loop
- ▶ 5 semiconductor outputs
- ▶ Monitors muting lamps
- ▶ Muting mode: sequential or parallel
- ▶ LED display for:
 - Switch status channel 1/2
 - Muting sensors
 - Light grid
 - Simultaneity requirement
 - Muting lamp error
- ▶ Semiconductor outputs signal:
 - Switch state of the safety contacts
 - Muting active
 - One of the muting lamps defective
 - Both muting lamps defective
 - Light grid (ESPE) active
- ▶ Plug-in connection terminals (either spring-loaded terminal or screw terminal)

Safety relays PNOZ X PMUT X1P

- ▶ See order reference for unit types

Block diagram/terminal configuration

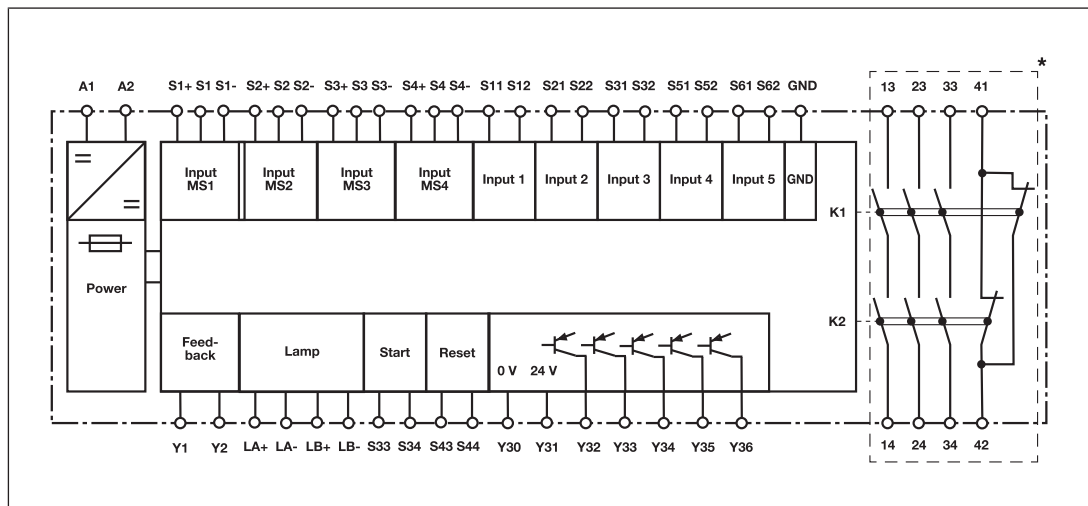

*Insulation between the non-marked area and the relay contacts: Basic insulation (over-voltage category III), Protective separation (overvoltage category II)

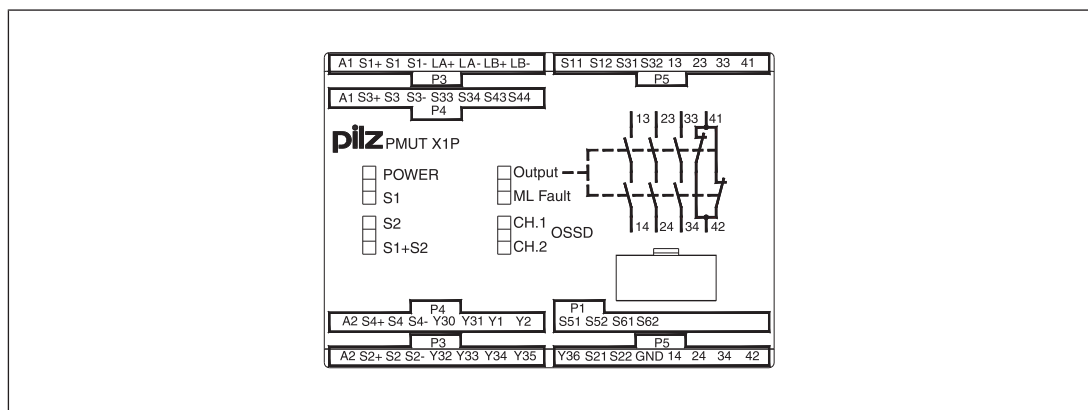

Safety relays PNOZ X PMUT X1P

Function description

The muting controller PMUT X1P is used for the temporary suspension of safety functions. This allows objects to be transported into and out of a danger zone without adversely affecting the safety function. When the supply voltage is applied the "POWER" LED will light. The unit is ready for operation when the feedback loop Y1-Y2 and the input circuit (e.g. light guard at S12 and S22 not interrupted) are closed. The muting sensors are not active.

- ▶ Start circuit S33-S34 is closed:
 - Safety contacts 13-14/23-24/33-34 are closed, auxiliary contact 41-42 is open.
 - Status indicators "Output", "OSSD CH.1" and "OSSD CH.2" are lit.
 - A high signal is present at the semiconductor output Y32 (ESPE state).
 - A high signal is present at the semiconductor output Y36 (switch state of safety contacts)
- ▶ Input circuit is opened (e.g. light guard at S12 and S22 interrupted):
 - Safety contacts 13-14/23-24/33-34 are opened redundantly, auxiliary contact 41-42 is closed.
 - Status indicators "Output", "OSSD CH.1" and "OSSD CH.2" go out.
 - A low signal is present at the semiconductor output Y36 (switch state of safety contacts).
 - A low signal is present at semiconductor output Y32 (ESPE state).

Safety relays PNOZ X PMUT X1P

Timing diagram

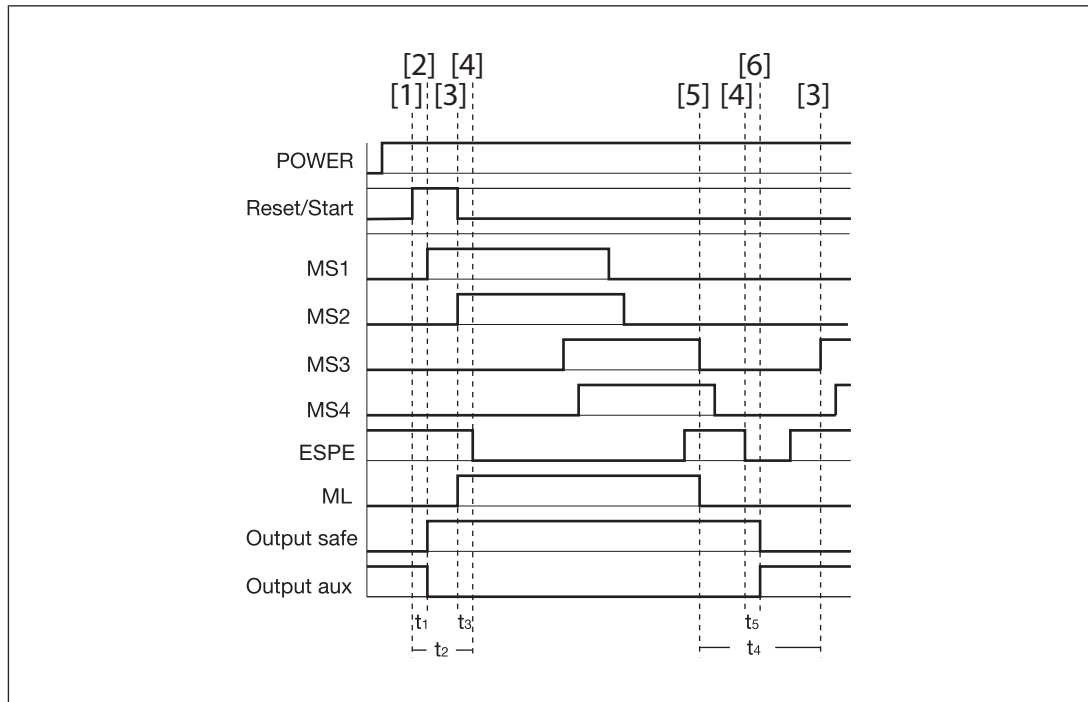

Legend

- ▶ Power: Supply voltage
- ▶ Start: Start button
- ▶ ESPE: Light guard
- ▶ MS1 ... MS2: Muting sensors
- ▶ ML: Muting lamps
- ▶ Output Safe: Safety contacts 13-14, 23-24, 33-34
- ▶ Output aux: Auxiliary contact 41-42
- ▶ [1]: Press start button
- ▶ [2]: Close safety contacts
- ▶ [3]: Muting on
- ▶ [4]: Light guard interrupted
- ▶ [5]: Muting off
- ▶ [6]: Open safety contacts
- ▶ t_1 : Switch-on delay safety contacts
- ▶ t_2 : Minimum start pulse duration
- ▶ t_3 : Minimum period before light guard may be interrupted
- ▶ t_4 : Recovery time after muting off
- ▶ t_5 : Delay-on de-energisation

Safety relays PNOZ X PMUT X1P

Operating modes

- ▶ Dual-channel operation (contact or semiconductor outputs from ESPE) without detection of shorts across contacts
- ▶ Dual-channel operation (contact or semiconductor outputs from ESPE) with detection of shorts across contacts: redundant input circuit, earth faults in the input circuit or shorts across the input circuits are detected.
- ▶ Monitored manual start: The supply voltage must be present and the safety circuits closed before the start contact is closed. The unit is not active until the start button has been operated once the waiting period has expired (see technical details).

Muting

The muting controller can be used for parallel or sequential muting:

- ▶ Parallel muting with 2 muting sensors

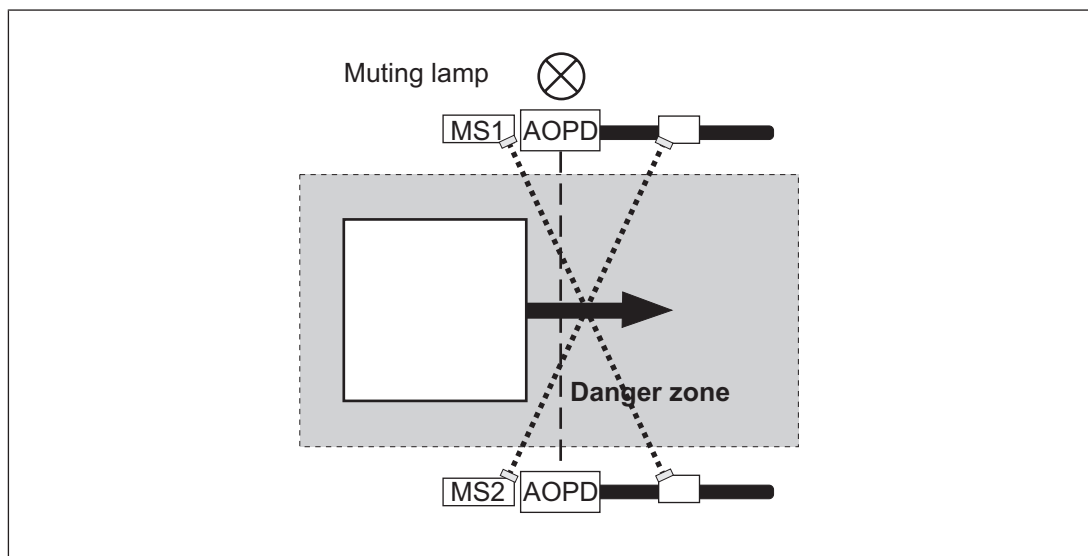

Safety relays PNOZ X PMUT X1P

- ▶ Parallel muting with 4 muting sensors

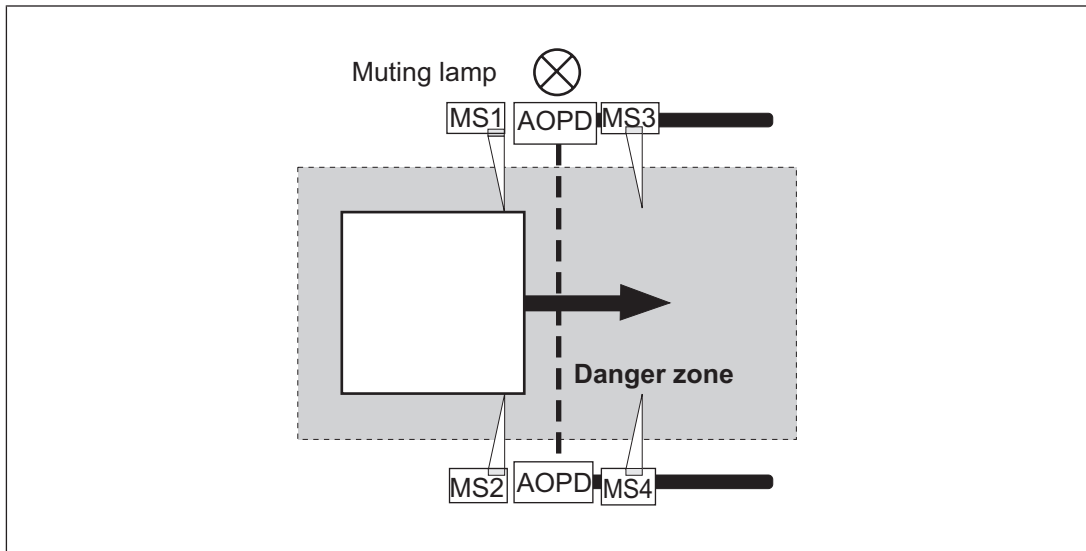

- ▶ Sequential muting with 4 muting sensors

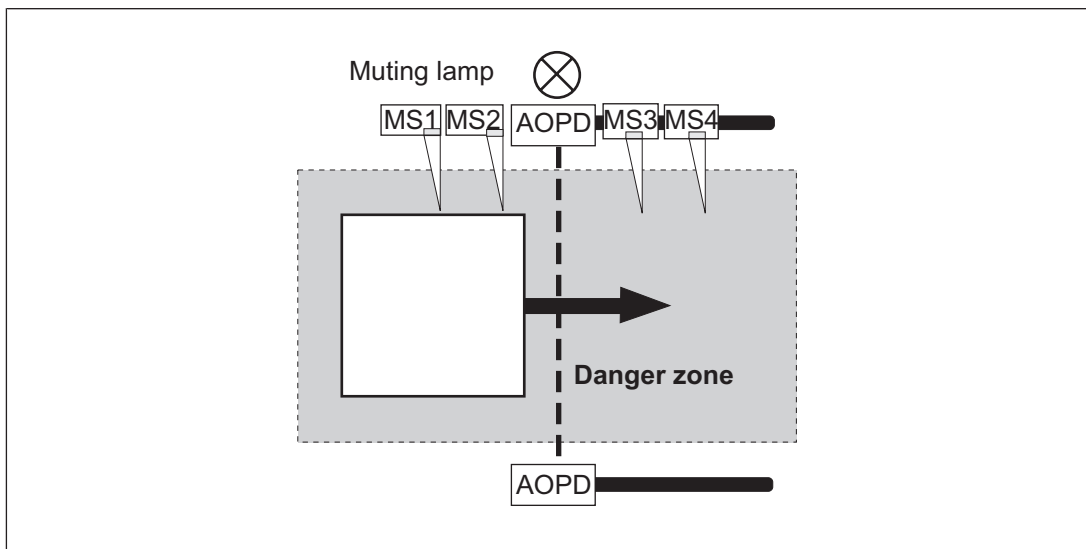

Muting sensors MS1 and MS2 must energise within 3 s (simultaneity). Muting starts when both muting sensors are active. The inputs of light guards S11-S12, S21-S22 and S31-S32 are muted. Status indicators "S1+S2" (Muting active), "S1", "S2" "OSSD CH.1" and "OSSD CH.2" are lit. A high signal is present at semiconductor output Y32 (muting active).

If the light guards are interrupted (inputs S12 and S22 not active), status indicators "OSSD CH.1" and "OSSD CH.2" will go out. A low signal is present at semiconductor output Y32 (ESPE state). Muting sensors MS3 and MS4 must energise while MS1 and MS2 are still active. Only then may MS1 and MS2 become inactive. The muting cycle will then continue. Muting is ended when one muting sensor at most (MS3 or MS4) is active.

Safety relays PNOZ X PMUT X1P

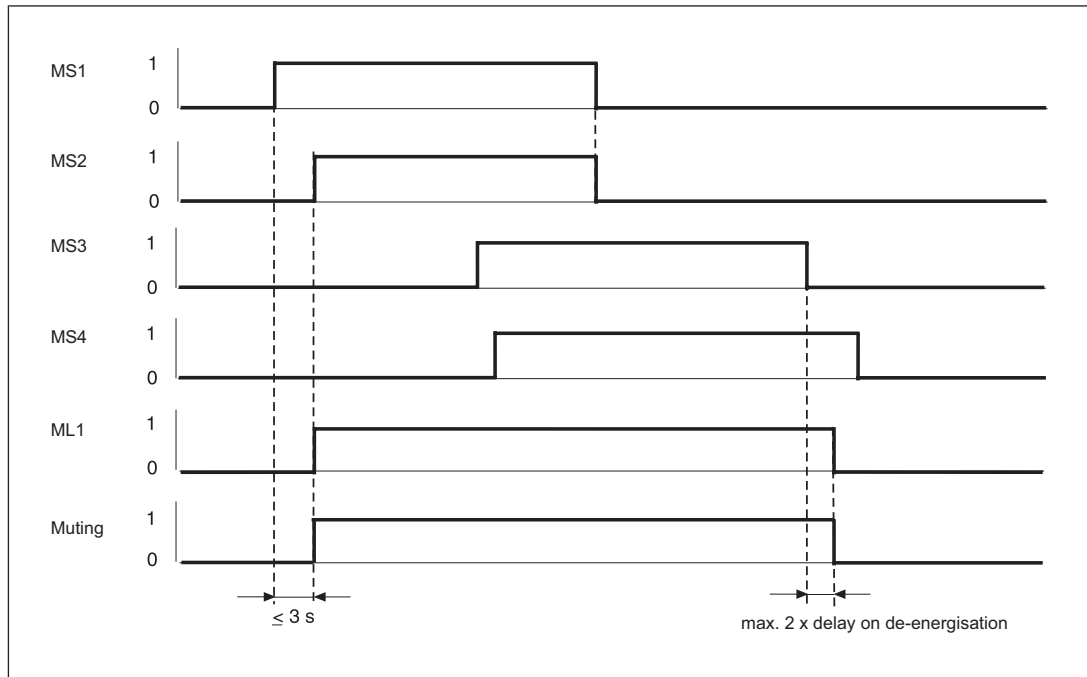

Legend:

- MS1: Muting sensor 1
- MS2: Muting sensor 2
- MS3: Muting sensor 3
- MS4: Muting sensor 4
- ML1: Muting lamp 1

Reset input

If the simultaneity requirement of 3 s is exceeded, the unit will go to a fault condition. Once the fault has been rectified, the simultaneity must be reset by operating the key switch at S43-S44. The start button S33-S34 must then be operated. The muting controller is ready for operation.

Additional inputs for light guard or safety contacts

Additional safety contacts can be connected to the muting controller at S51-S52 and S61-S62 (e.g. a dual-channel safety light guard with safe output contacts). These input circuits can monitor the muted ESPE. However, these inputs do not have a muting function. If the contacts connected at S51-S52 and S61-S62 are interrupted, safety contacts 13-14/23-24/33-34 are opened redundantly, auxiliary contact 41-42 is closed. Status indicator "Output" goes out. A low signal is present at semiconductor output Y36.

Safety relays PNOZ X PMUT X1P

Muting lamps

The muting controller PMUT X1P is designed for use with one or two muting lamps. As soon as the inputs of the light guard are muted, the Muting lamp ML1 will light. The PMUT X1P monitors the connected muting lamps during the muting cycle. If muting lamp ML1 is defective (e.g. coiled filament broken or lamp switched off), then the PMUT X1P automatically switches to muting lamp ML2. A high signal is present at semiconductor output Y34 (muting lamp 1 defective). If muting lamp ML2 is defective or is not connected, a high signal is present at semiconductor output Y35 (both muting lamps defective). The "ML Fault" LED is lit. If the light guards (ESPE) are interrupted when the muting lamps are defective, then safety contacts 13-14/23-24/33-34 are opened redundantly, auxiliary contact 41-42 is closed. Status indicators "Output", "OSSD CH.1" and "OSSD CH.2" go out.

Installation

- ▶ The unit should be installed in a control cabinet with a protection type of at least IP54.
- ▶ Use the notch on the rear of the unit to attach it to a DIN rail.
- ▶ Ensure the unit is mounted securely on a vertical DIN rail (35 mm) by using a fixing element (e.g. retaining bracket or an end angle).
- ▶ When installing the light guards (muting sensors, ESPE), it is essential that the respective standards and regulations are observed. If you are using reflective light barriers (parallel muting with 2 muting sensors), the light beams must cross within the danger zone.
- ▶ The start button has to be installed in such a way that the operator can see into the danger zone when operating the start button.

Wiring

Please note:

- ▶ Information given in the "[Technical details \[512\]](#)" must be followed.
- ▶ Outputs 13-14, 23-24, 33-34 are safety contacts; output 41-42 is an auxiliary contact (e.g. for display).
- ▶ Auxiliary contact 41-42 should **not** be used for safety circuits!
- ▶ Semiconductor outputs should **not** be used for safety circuits!
- ▶ Delivery status: S51-S52/S61-S62/Y1-Y2/S31-S32 are linked
- ▶ To prevent contact welding, a fuse should be connected before the output contacts (see [Technical details \[512\]](#)).
- ▶ Calculation of the max. cable length l_{\max} in the input circuit:

$$l_{\max} = \frac{R_{\text{I max}}}{R_1 / \text{km}}$$

$R_{\text{I max}}$ = max. overall cable resistance (see [Technical details \[512\]](#))

R_1 / km = cable resistance/km

- ▶ Use copper wire that can withstand 60/75 °C.

Safety relays PNOZ X PMUT X1P

- ▶ Sufficient fuse protection must be provided on all output contacts with capacitive and inductive loads.
- ▶ Do not switch low currents using contacts that have been used previously with high currents.
- ▶ Ensure the wiring and EMC requirements of IEC 60204-1 are met.
- ▶ Mechanical and optoelectronic sensors (safety light beam devices, safety light grids) are suitable for use.
- ▶ The safety contacts can be used to shut down the potentially hazardous movement.
- ▶ Only safe contact outputs (e.g. from safety light grids) may be used at S51-S52 and S61-S62. Do **not** connect safety light grids with semiconductor outputs.
- ▶ The cables for connecting the muting sensors to terminals S1/S3 and S2/S4 must be laid in separate sheathed cables!
- ▶ Only use muting lamps that have a luminous area of at least 1cm² and a luminosity of at least 200 cd/m², in accordance with EN 61496-1.
- ▶ When connecting magnetically operated, reed proximity switches, ensure that the max. peak inrush current (on the input circuit) does not overload the proximity switch.

Safety relays PNOZ X PMUT X1P

Preparing for operation

| Supply voltage | AC | DC |
|---|---------------|----------|
| | | |
| Input circuit | Semiconductor | Contacts |
| Muting sensors | | |
| Light grid (ESPE) Semiconductor output 2 x PNP Detection of shorts across con- tacts via light grid | | |
| Light grid (ESPE) Semiconductor output PNP/NPN Detection of shorts across con- tacts; - Semiconductor: via light grid - Contacts: via PMUT X1P | | |

Safety relays PNOZ X PMUT X1P

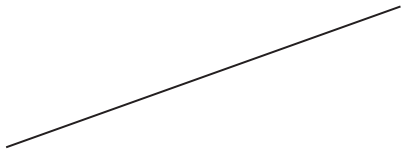
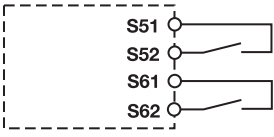
| Input circuit | Semiconductor | Contacts |
|---|---|---|
| Additional light grid, 2-channel, E-STOP pushbutton |  |  |

| Muting lamp | Semiconductor | Contacts |
|-------------|---------------|--|
| | |  |

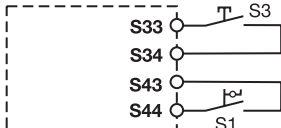
| Start circuit | Semiconductor | Contacts |
|------------------------------------|---------------|---|
| S1: Key switch S3: Start button | |  |

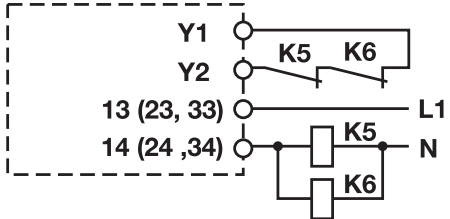
| Feedback loop | without feedback loop monitoring | with feedback loop monitoring |
|---|---|--|
| Link or contacts from external contactors |  |  |

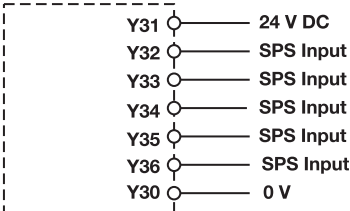
| Semiconductor output | Semiconductor | Contacts |
|---|---------------|--|
| Y32: Light grid active Y33: Muting active Y34: Muting lamp warning Y35: Both muting lamps defective Y36: Safety contacts closed | |  |

Safety relays PNOZ X PMUT X1P

Application example

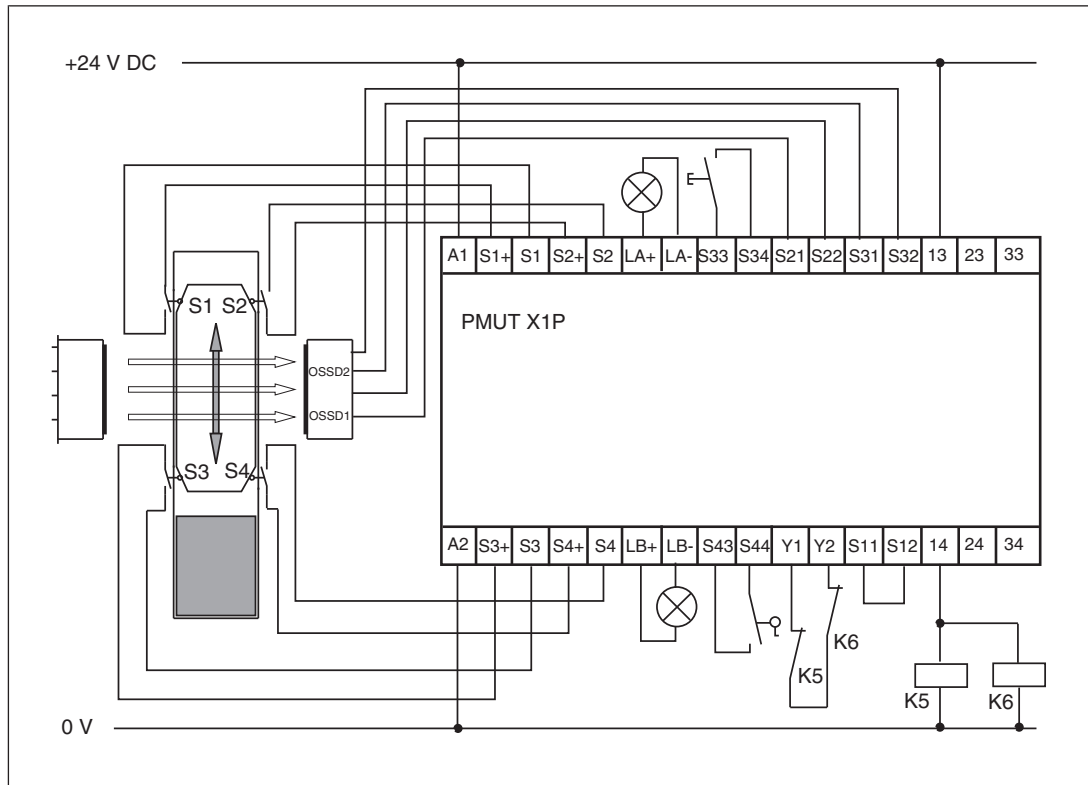

Dimensions in mm

* With spring-loaded terminals

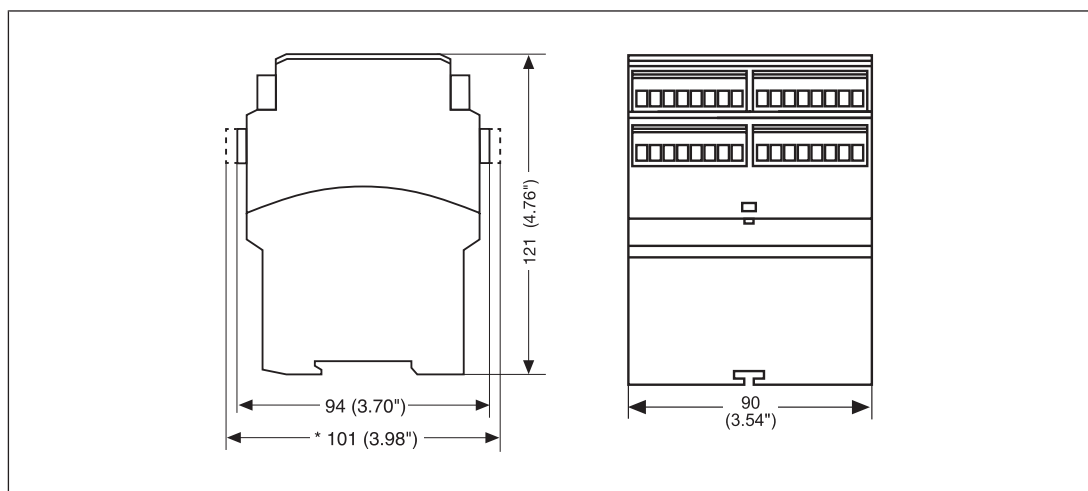

Safety relays PNOZ X PMUT X1P

Technical details

| General | 778010 | 788010 |
|--------------------------------------|--|--|
| Approvals | CCC, CE, EAC (Eurasian), TÜV, cULus Listed | CCC, CE, EAC (Eurasian), TÜV, cULus Listed |
| Electrical data | 778010 | 788010 |
| Supply voltage | | |
| Voltage | 24 V | 24 V |
| Kind | DC | DC |
| Voltage tolerance | -15 %/+10 % | -15 %/+10 % |
| Output of external power supply (DC) | 33 W | 33 W |
| Power consumption | 6 W | 6 W |
| Residual ripple DC | 48 % | 48 % |
| Duty cycle | 100 % | 100 % |
| Voltage at | | |
| Muting lamp DC | 24 V | 24 V |
| Muting lamp LED DC | 24 V | 24 V |
| Muting sensor DC | 24 V | 24 V |
| Current at | | |
| Muting lamp DC max. | 500 mA | 500 mA |
| Muting lamp LED DC min. | 40 mA | 40 mA |
| Muting sensor DC | 40 mA | 40 mA |
| Connected load min. | | |
| Muting lamp LED | 0,96 W | 0,96 W |
| Connected load max. | | |
| Muting sensors | 5 W | 5 W |
| Light beam device | 10 W | 10 W |
| Muting lamp | 12 W | 12 W |
| Inputs | 778010 | 788010 |
| Number | 9 | 9 |
| Voltage at | | |
| Input circuit DC | 24 V | 24 V |
| Start circuit DC | 24 V | 24 V |
| Feedback loop DC | 24 V | 24 V |
| Current at | | |
| Input circuit DC | 25 mA | 25 mA |
| Start circuit DC | 40 mA | 40 mA |
| Feedback loop DC | 40 mA | 40 mA |
| Max. inrush current impulse | | |
| Current pulse, input circuit | 0,07 A | 0,07 A |
| Min. input resistance at power-on | 460 Ohm | 460 Ohm |

Safety relays PNOZ X PMUT X1P

| Inputs | 778010 | 788010 |
|---|--------------|--------------|
| Max. overall cable resistance RI-max | | |
| Dual-channel without detection of shorts across contacts at UB DC | 70 Ohm | 70 Ohm |
| Dual-channel with detection of shorts across contacts at UB DC | 15 Ohm | 15 Ohm |
| Semiconductor outputs | 778010 | 788010 |
| Number | 4 | 4 |
| Voltage | 24 V | 24 V |
| Current | 20 mA | 20 mA |
| External supply voltage | 24 V | 24 V |
| Voltage tolerance | -20 %/+20 % | -20 %/+20 % |
| Relay outputs | 778010 | 788010 |
| Number of output contacts | | |
| Safety contacts (N/O), instantaneous | 3 | 3 |
| Auxiliary contacts (N/C) | 1 | 1 |
| Max. short circuit current IK | 1 kA | 1 kA |
| Utilisation category | | |
| In accordance with the standard | EN 60947-4-1 | EN 60947-4-1 |
| Utilisation category of safety contacts | | |
| AC1 at | 240 V | 240 V |
| Min. current | 0,01 A | 0,01 A |
| Max. current | 8 A | 8 A |
| Max. power | 2000 VA | 2000 VA |
| DC1 at | 24 V | 24 V |
| Min. current | 0,01 A | 0,01 A |
| Max. current | 8 A | 8 A |
| Max. power | 200 W | 200 W |
| Utilisation category of auxiliary contacts | | |
| AC1 at | 240 V | 240 V |
| Min. current | 0,01 A | 0,01 A |
| Max. current | 8 A | 8 A |
| Max. power | 2000 VA | 2000 VA |
| DC1 at | 24 V | 24 V |
| Min. current | 0,01 A | 0,01 A |
| Max. current | 8 A | 8 A |
| Max. power | 200 W | 200 W |

Safety relays PNOZ X PMUT X1P

| Relay outputs | 778010 | 788010 |
|--|--------------------------------------|--------------------------------------|
| Utilisation category | | |
| In accordance with the standard | EN 60947-5-1 | EN 60947-5-1 |
| Utilisation category of safety contacts | | |
| AC15 at | 240 V | 240 V |
| Max. current | 5 A | 5 A |
| DC13 (6 cycles/min) at | 24 V | 24 V |
| Max. current | 5 A | 5 A |
| Utilisation category of auxiliary contacts | | |
| AC15 at | 230 V | 230 V |
| Max. current | 5 A | 5 A |
| DC13 (6 cycles/min) at | 24 V | 24 V |
| Max. current | 5 A | 5 A |
| Utilisation category in accordance with UL | | |
| Voltage | 240 V AC G. P. | 240 V AC G. P. |
| With current | 8 A | 8 A |
| Voltage | 24 V DC Resistive | 24 V DC Resistive |
| With current | 5 A | 5 A |
| Pilot Duty | B300, R300 | B300, R300 |
| External contact fuse protection, safety contacts | | |
| In accordance with the standard | EN 60947-5-1 | EN 60947-5-1 |
| Max. melting integral | 240 A²s | 240 A²s |
| Blow-out fuse, quick | 10 A | 10 A |
| Blow-out fuse, slow | 6 A | 6 A |
| Blow-out fuse, gG | 10 A | 10 A |
| Circuit breaker 24V AC/DC, characteristic B/C | 6 A | 6 A |
| External contact fuse protection, auxiliary contacts | | |
| Max. melting integral | 240 A²s | 240 A²s |
| Blow-out fuse, quick | 10 A | 10 A |
| Blow-out fuse, slow | 6 A | 6 A |
| Blow-out fuse, gG | 10 A | 10 A |
| Circuit breaker 24 V AC/DC, characteristic B/C | 6 A | 6 A |
| Contact material | AgSnO₂ + 0,2 µm Au | AgSnO₂ + 0,2 µm Au |

Safety relays PNOZ X PMUT X1P

| | | |
|--|---------------|---------------|
| Conventional thermal current while loading several contacts | 778010 | 788010 |
| I _{th} per contact at UB DC; AC1: 240 V, DC1: 24 V | | |
| Conv. therm. current with 1 contact | 8 A | 8 A |
| Conv. therm. current with 2 contacts | 6 A | 6 A |
| Conv. therm. current with 3 contacts | 5 A | 5 A |
| Times | 778010 | 788010 |
| Switch-on delay | | |
| With monitored start with rising edge typ. | 40 ms | 40 ms |
| With monitored start with rising edge max. | 80 ms | 80 ms |
| Delay-on de-energisation | | |
| With E-STOP typ. | 8 ms | 8 ms |
| With E-STOP max. | 20 ms | 20 ms |
| With power failure typ. | 490 ms | 490 ms |
| With power failure max. | 700 ms | 700 ms |
| After safety function is triggered typ. | 15 ms | 15 ms |
| After safety function is triggered max. | 20 ms | 20 ms |
| Recovery time at max. switching frequency 1/s | | |
| After E-STOP | 320 ms | 320 ms |
| After power failure | 1 s | 1 s |
| Waiting period with a monitored start | | |
| With rising edge | 300 ms | 300 ms |
| Min. start pulse duration with a monitored start | | |
| With rising edge | 40 ms | 40 ms |
| Supply interruption before de-energisation in the input circuit | | |
| | 5 ms | 5 ms |
| Supply interruption before de-energisation | | |
| | 20 ms | 20 ms |
| Simultaneity, channel 1 and 2 max. | | |
| | 3 s | 3 s |
| Environmental data | 778010 | 788010 |
| Climatic suitability | EN 60068-2-78 | EN 60068-2-78 |
| Ambient temperature | | |
| Temperature range | -10 - 55 °C | -10 - 55 °C |

Safety relays PNOZ X PMUT X1P

| Environmental data | 778010 | 788010 |
|---|---|---|
| Storage temperature | | |
| Temperature range | -40 - 85 °C | -40 - 85 °C |
| Climatic suitability | | |
| Humidity | 93 % r. h. at 40 °C | 93 % r. h. at 40 °C |
| Condensation during operation | Not permitted | Not permitted |
| EMC | EN 61000-6-2, EN 61326-3-1, EN 61496-1 | EN 61000-6-2, EN 61326-3-1, EN 61496-1 |
| Vibration | | |
| In accordance with the standard | EN 60068-2-6 | EN 60068-2-6 |
| Frequency | 10 - 55 Hz | 10 - 55 Hz |
| Amplitude | 0,35 mm | 0,35 mm |
| Airgap creepage | | |
| In accordance with the standard | EN 60947-1 | EN 60947-1 |
| Overvoltage category | III / II | III / II |
| Pollution degree | 2 | 2 |
| Rated insulation voltage | 250 V | 250 V |
| Rated impulse withstand voltage | 4 kV | 4 kV |
| Protection type | | |
| Mounting area (e.g. control cabinet) | IP54 | IP54 |
| Housing | IP40 | IP40 |
| Terminals | IP20 | IP20 |
| Mechanical data | 778010 | 788010 |
| Mounting position | Any | Any |
| Mechanical life | 10,000,000 cycles | 10,000,000 cycles |
| Material | | |
| Bottom | PPO UL 94 V0 | PPO UL 94 V0 |
| Front | ABS UL 94 V0 | ABS UL 94 V0 |
| Top | PPO UL 94 V0 | PPO UL 94 V0 |
| Connection type | Screw terminal | Spring-loaded terminal |
| Mounting type | plug-in | plug-in |
| Conductor cross section with screw terminals | | |
| 1 core flexible | 0,2 - 2,5 mm², 24 - 12 AWG | – |
| 2 core with the same cross section, flexible with crimp connectors, no plastic sleeve | 0,2 - 1 mm², 24 - 16 AWG | – |
| 2 core with the same cross section, flexible without crimp connectors or with TWIN crimp connectors | 0,2 - 1,5 mm², 24 - 16 AWG | – |
| Torque setting with screw terminals | 0,5 Nm | – |

Safety relays PNOZ X PMUT X1P

| Mechanical data | 778010 | 788010 |
|---|--------|---|
| Conductor cross section with spring-loaded terminals: Flexible with/without crimp connector | – | 0,2 - 1,5 mm ² , 24 - 16 AWG |
| Spring-loaded terminals: Terminal points per connection | – | 2 |
| Stripping length with spring-loaded terminals | – | 8 mm |
| Dimensions | | |
| Height | 94 mm | 101 mm |
| Width | 90 mm | 90 mm |
| Depth | 121 mm | 121 mm |
| Weight | 565 g | 565 g |

Where standards are undated, the 2014-07 latest editions shall apply.

Safety characteristic data

| Operating Mode | EN ISO 13849-1: 2015 PL | EN ISO 13849-1: 2015 Category | EN 62061 SIL CL | EN 62061 PFH _D [1/h] | IEC 61511 SIL | IEC 61511 PFD | EN ISO 13849-1: 2015 T _M [year] |
|-----------------|----------------------------|----------------------------------|--------------------|------------------------------------|------------------|------------------|---|
| Muting active | PL e | Cat. 3 | SIL CL 3 | 8,35E-09 | SIL 3 | 5,54E-04 | 20 |
| Muting inactive | PL e | Cat. 4 | SIL CL 3 | 1,45E-09 | SIL 3 | 2,49E-06 | 20 |

All the units used within a safety function must be considered when calculating the safety characteristic data.

The PFH value depends on the switching frequency and the load on the relay output. If the service life graphs are not accessible, the stated PFH value can be used irrespective of the switching frequency and the load, as the PFH value already considers the relay's B10d value as well as the failure rates of the other components.

Supplementary data

The PFH value depends on the switching frequency and the load on the relay output. If the service life graphs are not accessible, the stated PFH value can be used irrespective of the switching frequency and the load, as the PFH value already considers the relay's B10d value as well as the failure rates of the other components.

Safety relays PNOZ X PMUT X1P

Service life graph

The service life graphs indicate the number of cycles from which failures due to wear must be expected. The wear is mainly caused by the electrical load; the mechanical load is negligible.

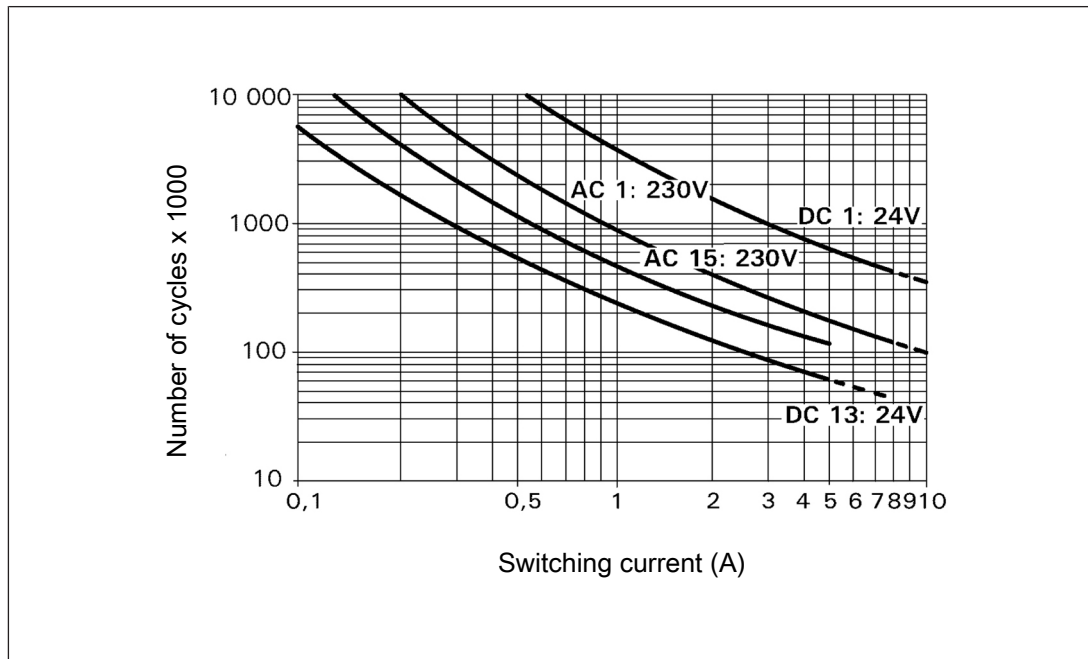

Example

- ▶ Inductive load: 0.2 A
- ▶ Utilisation category: AC15
- ▶ Contact service life: 4 000 000 cycles

Provided the application to be implemented requires fewer than 4 000 000 cycles, the PFH value (see Technical details) can be used in the calculation.

To increase the service life, sufficient spark suppression must be provided on all output contacts. With capacitive loads, any power surges that occur must be noted. With DC contactors, use flywheel diodes for spark suppression.

Order reference

| Product type | Features | Connection type | Order no. |
|--------------|----------|------------------------|-----------|
| PMUT X1P C | 24 VDC | Spring-loaded terminal | 788 010 |
| PMUT X1P | 24 VDC | Screw terminals | 778 010 |

Safety relays PNOZ X PSWZ X1P

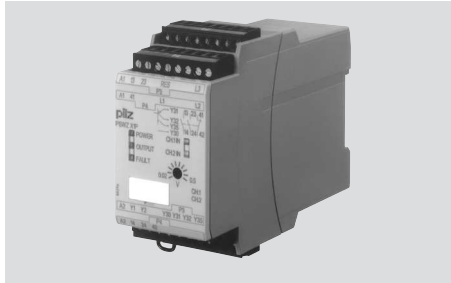

Unit features

- ▶ Measuring inputs for 3- or 1-phase motors
- ▶ Measuring voltage on both channels can be set jointly
- ▶ 1 Reset input
- ▶ Positive-guided relay outputs:
 - 2 safety contacts (N/O), instantaneous
 - 1 auxiliary contact (N/C), instantaneous
- ▶ 2 semiconductor outputs
- ▶ LED display for:
 - Standstill on channel 1/2
 - Supply voltage/fault
- ▶ Semiconductor outputs signal:
 - Supply voltage/fault
 - Switch status
- ▶ Feedback loop for monitoring external contactors
- ▶ Plug-in connection terminals (either spring-loaded terminal or screw terminal)
- ▶ See order reference for unit types

Safety relays PNOZ X PSWZ X1P

Block diagram/terminal configuration

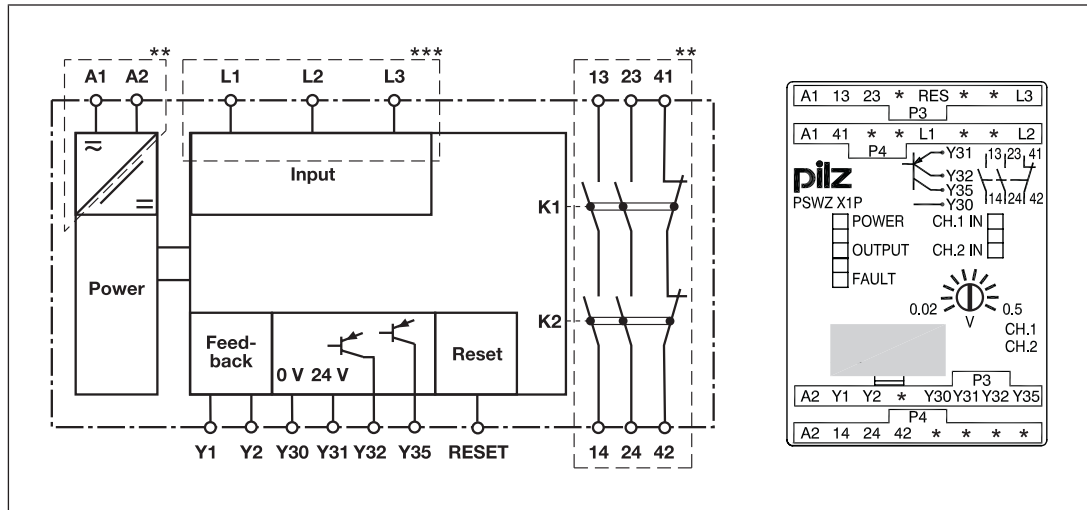

**Insulation against the non-marked area and between the relay contacts: Basic insulation (overvoltage category III), protective separation (overvoltage category II); at 250 V, 4 kV

***Insulation against the non-marked area and between the measurement connections: Basic insulation (overvoltage category III), protective separation (overvoltage category II); at 690 V, 6 kV

- ▶ Channel 1: L1-L3
- ▶ Channel 2: L2-L3

Function description

The device uses two separate measuring channels to measure the regenerated voltage, induced from the motor during the rundown period. If the voltage falls below the set response value (standstill threshold), the PSWZ X1P enables the monitored plant.

When used with frequency converters, the PSWZ X1P cannot detect standstill until the controller inhibit has been switched off.

After the supply voltage U_B is switched on, the unit performs a self test. The unit simulates a situation in which the release value is exceeded and the measuring circuit has an open circuit. The correct function of the output relay and feedback loop is also tested. The test takes approx. 1.5 s.

The unit is ready for operation when the feedback loop is closed and the measuring circuits are not interrupted.

- ▶ Procedure when the measuring voltage falls below the response value U_{on} on both channels L1-L3 and L2-L3:
 - LEDs "POWER", "CH.1 IN", "CH.2 IN" and "OUTPUT" are lit.
 - Safety contacts 13-14 and 23-24 are closed, auxiliary contact 41-42 is open.
 - A high signal is present at semiconductor output Y32.

Safety relays PNOZ X PSWZ X1P

- ▶ Procedure when after the motor has started, the voltage in one of the two measuring circuits exceeds the release value U_{off} :
 - Safety contacts 13-14 and 23-24 are opened redundantly, auxiliary contact 41-42 is closed.
 - A low signal is present at semiconductor output Y32.
 - LEDs "CH.1 IN", "CH.2 IN" and "OUTPUT" go out.

To reactivate, the voltage at both channels L1-L3 and L2-L3 must fall below the response value U_{on} within the time t_g (simultaneity monitoring) and the feedback loop must be closed. The response value U_{on} can be set jointly for both channels in order to suit the motor that is to be monitored. The release value U_{off} (hysteresis) corresponds to twice the response value.

If the simultaneity requirement is exceeded, the "FAULT" LED is lit and on the semiconductor output Y35 there is a High signal. The PSWZ X1P does not enable the monitored plant. The fault is reset by applying a High signal and then a Low signal at the reset input.

Self test

An internal self test is carried out during initial commissioning and each time the supply voltage is switched off and on. The process simulates switching all measuring voltages on and then off again. Provided no error occurs during the self test, the unit will then be ready for operation.

Operating modes

- ▶ Single-phase operation:
 - One measuring circuit (calculated at two different measuring points) affects both channels
- ▶ Three-phase operation:
 - Two redundant (identical) measuring circuits affect channel 1 and 2
 - Voltages in the measuring circuit are monitored (failsafe in the event of a short circuit)

Safety relays PNOZ X PSWZ X1P

Timing diagram

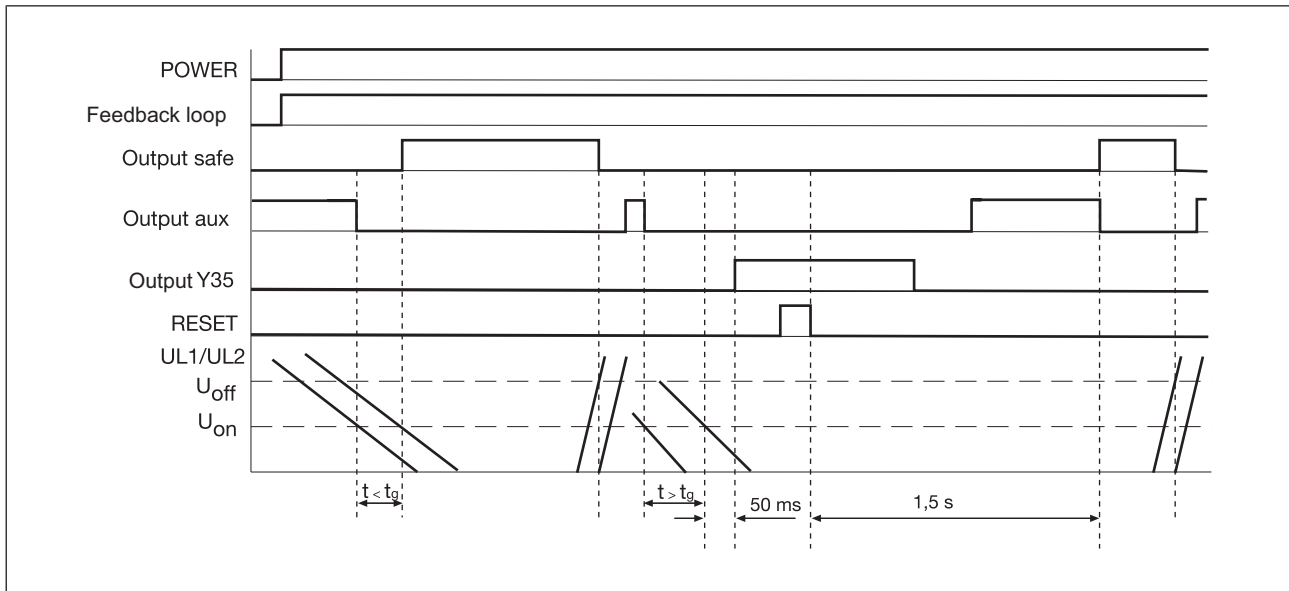

Legend

- ▶ POWER: Supply voltage
- ▶ UL1/UL2: Input circuit L1, L2, L3
- ▶ Feedback loop: Feedback loop Y1-Y2
- ▶ Output safe: Safety contacts 13-14, 23-24
- ▶ Output aux: Auxiliary contact 41-42
- ▶ Output Y35: Semiconductor output for fault signal
- ▶ RESET: Reset input
- ▶ U_{on} : Response value
- ▶ U_{off} : Release value
- ▶ t_g : Simultaneity

Installation

- ▶ The unit should be installed in a control cabinet with a protection type of at least IP54.
- ▶ Use the notch on the rear of the unit to attach it to a DIN rail.
- ▶ Ensure the unit is mounted securely on a vertical DIN rail (35 mm) by using a fixing element (e.g. retaining bracket or an end angle).

Safety relays PNOZ X PSWZ X1P

Wiring

Please note:

- ▶ Information given in the "[Technical details \[527\]](#)" must be followed.
- ▶ Outputs 13-14, 23-24 are safety contacts, the output 41-42 is an auxiliary contact (e.g. for display).
- ▶ Auxiliary contact 41-42 should **not** be used for safety circuits!
- ▶ To prevent contact welding, a fuse should be connected before the output contacts (see [Technical details \[527\]](#)).
- ▶ Calculation of the max. cable length l_{\max} in the input circuit:

$$l_{\max} = \frac{R_{l_{\max}}}{R_l / \text{km}}$$

$R_{l_{\max}}$ = max. overall cable resistance (see [Technical details \[527\]](#))

R_l / km = cable resistance/km

- ▶ Use copper wire that can withstand 60/75 °C.
- ▶ Sufficient fuse protection must be provided on all output contacts with capacitive and inductive loads.
- ▶ Do not switch low currents using contacts that have been used previously with high currents.
- ▶ Ensure the wiring and EMC requirements of IEC 60204-1 are met.
- ▶ When used with converters: Please comply with the information regarding installation and wiring in the documentation of the converter. Use screened cable for the wiring between the PSWZ X1P and the motor. Connect the cable screening on the motor.
- ▶ Protect the measuring circuits according to the conductor cross section.
- ▶ Single-phase motor: Connect terminal L1 directly to motor connection terminal L, and terminal L3 directly to motor connection terminal N. Connect terminal L2 directly to the element that switches the motor on (contactor, converter, etc.). Separate cables with separate insulation should be used for the measuring voltages L1 and L2. The cables should also be physically separate.
- ▶ Three-phase motor: Connect the connection terminals L1, L2 and L3 directly to the motor connection terminals L1, L2 and L3.
- ▶ Do **not** connect the terminals labelled "***".

Safety relays PNOZ X PSWZ X1P

Preparing for operation

Connection

| Supply voltage | AC | DC |
|---|-------------------------------|----------------------------------|
| | | |
| Input circuit | Single-phase motor | Three-phase motor |
| <p>Single-phase motor = single-phase measurement signal evaluation</p> <p>Three-phase motor = two-phase measurement signal evaluation</p> | | |
| Single-phase measurement signal evaluation | / | |
| Feedback loop | with feedback loop monitoring | without feedback loop monitoring |
| Contacts from external contactors or link | | |
| Semiconductor output | | |
| <p>Y32: Semiconductor output for switch status</p> <p>Y35: Semiconductor output for fault signal</p> | | |

Safety relays PNOZ X PSWZ X1P

Semiconductor input

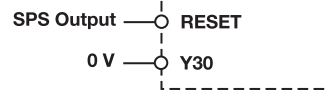

Set standstill detection

- ▶ Turn the potentiometer to the left-hand stop (default setting)
- ▶ Set standstill detection
 - At motor standstill, the LEDs "CH.1 IN" and "CH.2 IN" must light up. If the LEDs do not light in the default setting, turn the potentiometer gradually to the right until the LEDs "CH.1 IN" and "CH.2 IN" light up.
 - If the simultaneity requirement is met, the "OUTPUT" LED will also light up. Safety contacts 13-14 and 23-24 are closed, auxiliary contact 41-42 is open, there is a High signal at the semiconductor output Y32.
 - If the simultaneity requirement is exceeded, the "FAULT" LED will light up. Safety contacts 13-14 and 23-24 are open, auxiliary contact 41-42 is closed, a low signal is present at semiconductor output Y32. Reset the error by a pulse (High- Low- signal) at the reset input.
- ▶ Test standstill detection
 - Close the feedback loop, start up the motor and then switch it off again. As soon as the motor is at standstill, the LEDs "CH.1 IN", "CH.2 IN" and "OUTPUT" light up. Safety contacts 13-14 and 23-24 are closed, auxiliary contact 41-42 is open, there is a High signal at the semiconductor output Y32.

Safety relays PNOZ X PSWZ X1P

Application example

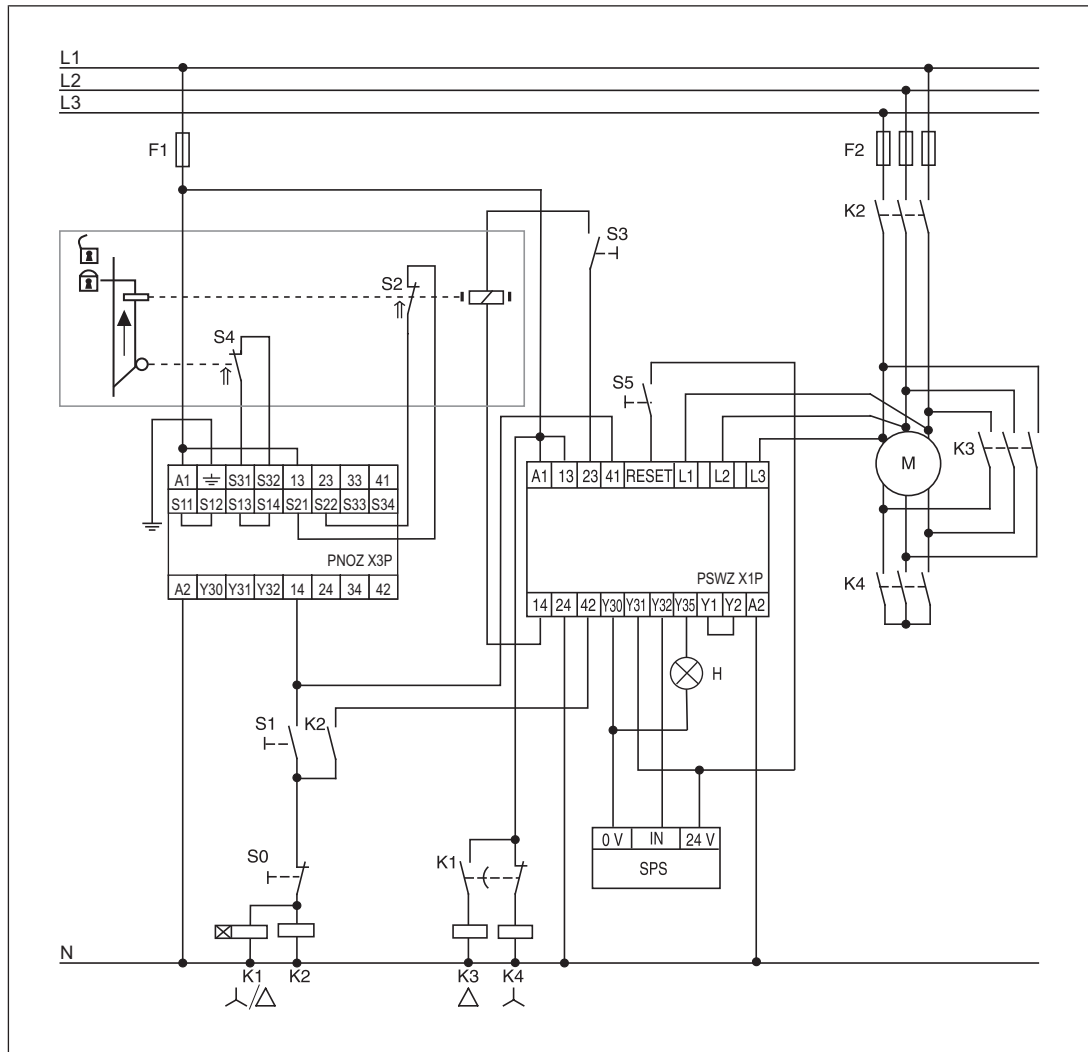



Standstill detection only with closed star contactor contacts

Legend

- ▶ S0: Off switch
- ▶ S1: On switch
- ▶ S2/S4: Safety gate switch
- ▶ S3: Release
- ▶ S5: Reset button
- ▶ K1: Star/delta control relay
- ▶ K2: Motor contactor
- ▶ K3: Delta contactor
- ▶ K4: Star contactor
- ▶ H: Fault indicator

Safety relays PNOZ X PSWZ X1P

- ▶ : Operated element
- ▶ : Gate open
- ▶ : Gate closed

Dimensions in mm

* with spring-loaded terminals

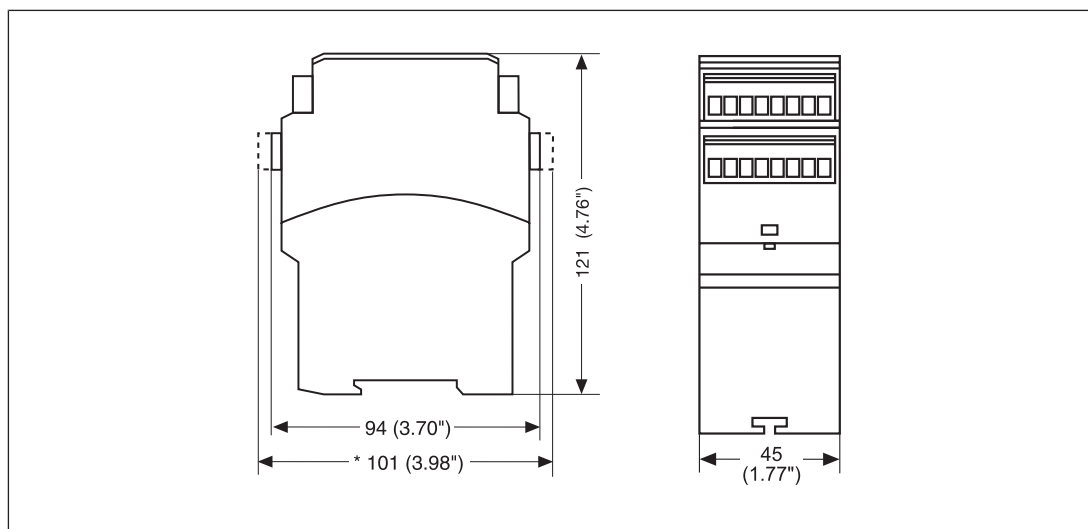

Technical details

Order no. 777949 – 777950

See below for more order numbers

| General | 777949 | 777950 |
|--------------------------------------|--|--|
| Approvals | CCC, CE, EAC (Eurasian), TÜV, cULus Listed | CCC, CE, EAC (Eurasian), TÜV, cULus Listed |
| Electrical data | 777949 | 777950 |
| Supply voltage | | |
| Voltage | 24 - 240 V | 24 - 240 V |
| Kind | AC/DC | AC/DC |
| Voltage tolerance | -15 %/+10 % | -15 %/+10 % |
| Output of external power supply (AC) | 5 VA | 5 VA |
| Output of external power supply (DC) | 3 W | 3 W |
| Frequency range AC | 50 - 60 Hz | 50 - 60 Hz |
| Residual ripple DC | 160 % | 160 % |

Safety relays PNOZ X PSWZ X1P

| Electrical data | 777949 | 777950 |
|---|---------------|---------------|
| Max. inrush current at UB | 10 A | 10 A |
| Duty cycle | 100 % | 100 % |
| Measuring circuit | 777949 | 777950 |
| Min. measuring voltage | 0,0 V | 0,0 V |
| Max. measuring voltage | 690 V | 690 V |
| Measuring voltage in accordance with UL | 600 V | 600 V |
| Frequency range | 0 - 3 kHz | 0 - 3 kHz |
| Input resistance | 1.300 kOhm | 1.300 kOhm |
| Switching threshold per channel | | |
| Response value Uon (adjustable) | 20 - 500 mV | 120 - 3000 mV |
| Release value Uoff | 2 x Uon | 2 x Uon |
| Inputs | 777949 | 777950 |
| Voltage at | | |
| Feedback loop DC | 24 V | 24 V |
| Current at | | |
| Feedback loop DC | 35 mA | 35 mA |
| Max. inrush current impulse | | |
| Current pulse, feedback loop | 0,12 A | 0,12 A |
| Pulse duration, feedback loop | 0,1 s | 0,1 s |
| Reset input | 777949 | 777950 |
| Low signal | < 5 V | < 5 V |
| High signal | > 15 V | > 15 V |
| Current | 20 mA | 20 mA |
| Semiconductor outputs | 777949 | 777950 |
| Number | 2 | 2 |
| Voltage | 24 V | 24 V |
| Current | 50 mA | 50 mA |
| External supply voltage | 24 V | 24 V |
| Voltage tolerance | -20 %/+20 % | -20 %/+20 % |
| Relay outputs | 777949 | 777950 |
| Number of output contacts | | |
| Safety contacts (N/O), instantaneous | 2 | 2 |
| Auxiliary contacts (N/C) | 1 | 1 |
| Max. short circuit current IK | 1 kA | 1 kA |
| Utilisation category | | |
| In accordance with the standard | EN 60947-4-1 | EN 60947-4-1 |

Safety relays PNOZ X PSWZ X1P

| Relay outputs | 777949 | 777950 |
|--|----------------|----------------|
| Utilisation category of safety contacts | | |
| AC1 at | 240 V | 240 V |
| Min. current | 0,01 A | 0,01 A |
| Max. current | 6 A | 6 A |
| Max. power | 1500 VA | 1500 VA |
| DC1 at | 24 V | 24 V |
| Min. current | 0,01 A | 0,01 A |
| Max. current | 6 A | 6 A |
| Max. power | 150 W | 150 W |
| Utilisation category of auxiliary contacts | | |
| AC1 at | 240 V | 240 V |
| Min. current | 0,01 A | 0,01 A |
| Max. current | 6 A | 6 A |
| Max. power | 1500 VA | 1500 VA |
| DC1 at | 24 V | 24 V |
| Min. current | 0,01 A | 0,01 A |
| Max. current | 6 A | 6 A |
| Max. power | 150 W | 150 W |
| Utilisation category | | |
| In accordance with the standard | EN 60947-5-1 | EN 60947-5-1 |
| Utilisation category of safety contacts | | |
| AC15 at | 230 V | 230 V |
| Max. current | 3 A | 3 A |
| DC13 (6 cycles/min) at | 24 V | 24 V |
| Max. current | 4 A | 4 A |
| Utilisation category of auxiliary contacts | | |
| AC15 at | 230 V | 230 V |
| Max. current | 3 A | 3 A |
| DC13 (6 cycles/min) at | 24 V | 24 V |
| Max. current | 4 A | 4 A |
| Utilisation category in accordance with UL | | |
| Voltage | 240 V AC G. P. | 240 V AC G. P. |
| With current | 6 A | 6 A |

Safety relays PNOZ X PSWZ X1P

| Relay outputs | 777949 | 777950 |
|--|---------------------------|---------------------------|
| External contact fuse protection, safety contacts | | |
| In accordance with the standard | EN 60947-5-1 | EN 60947-5-1 |
| Max. melting integral | 66 A²s | 66 A²s |
| Blow-out fuse, quick | 6 A | 6 A |
| Blow-out fuse, slow | 4 A | 4 A |
| Blow-out fuse, gG | 6 A | 6 A |
| Circuit breaker 24V AC/DC, characteristic B/C | 4 A | 4 A |
| External contact fuse protection, auxiliary contacts | | |
| Max. melting integral | 66 A²s | 66 A²s |
| Blow-out fuse, quick | 6 A | 6 A |
| Blow-out fuse, slow | 4 A | 4 A |
| Blow-out fuse, gG | 6 A | 6 A |
| Circuit breaker 24 V AC/DC, characteristic B/C | 4 A | 4 A |
| Conventional thermal current | 6 A | 6 A |
| Contact material | AgCuNi + 0,2 µm Au | AgCuNi + 0,2 µm Au |
| Conventional thermal current while loading several contacts | 777949 | 777950 |
| I _{th} per contact at UB DC; AC1: 240 V, DC1: 24 V | | |
| Conv. therm. current with 1 contact | 6 A | 6 A |
| Conv. therm. current with 2 contacts | 4 A | 4 A |
| Times | 777949 | 777950 |
| Delay-on de-energisation | | |
| After motor on max. | 170 ms | 170 ms |
| Max. switch-on delay | | |
| After motor standstill max. | 1.500 ms | 1.500 ms |
| After power on max. | 2.200 ms | 2.200 ms |
| Recovery time at max. switching frequency 1/s | | |
| After motor on | 2.200 ms | 2.200 ms |
| Supply interruption before de-energisation | | |
| | 20 ms | 20 ms |
| Simultaneity, channel 1 and 2 max. | 7 s | 7 s |
| Environmental data | 777949 | 777950 |
| Climatic suitability | EN 60068-2-78 | EN 60068-2-78 |

Safety relays PNOZ X PSWZ X1P

| Environmental data | 777949 | 777950 |
|--------------------------------------|---|---|
| Ambient temperature | | |
| Temperature range | -10 - 55 °C | -10 - 55 °C |
| Storage temperature | | |
| Temperature range | -40 - 85 °C | -40 - 85 °C |
| Climatic suitability | | |
| Humidity | 93 % r. h. at 40 °C | 93 % r. h. at 40 °C |
| Condensation during operation | Not permitted | Not permitted |
| EMC | EN 60947-5-1, EN 61000-6-2, EN 61000-6-4, EN 61326-3-1 | EN 60947-5-1, EN 61000-6-2, EN 61000-6-4, EN 61326-3-1 |
| Vibration | | |
| In accordance with the standard | EN 60068-2-6 | EN 60068-2-6 |
| Frequency | 10 - 55 Hz | 10 - 55 Hz |
| Amplitude | 0,35 mm | 0,35 mm |
| Airgap creepage | | |
| In accordance with the standard | EN 60947-1 | EN 60947-1 |
| Overvoltage category | III / II | III / II |
| Pollution degree | 2 | 2 |
| Rated insulation voltage | 690 V | 690 V |
| Rated impulse withstand voltage | 6 kV | 6 kV |
| Protection type | | |
| Mounting area (e.g. control cabinet) | IP54 | IP54 |
| Housing | IP40 | IP40 |
| Terminals | IP20 | IP20 |
| Mechanical data | 777949 | 777950 |
| Mounting position | Any | Any |
| Mechanical life | 10,000,000 cycles | 10,000,000 cycles |
| Material | | |
| Bottom | PPO UL 94 V0 | PPO UL 94 V0 |
| Front | ABS UL 94 V0 | ABS UL 94 V0 |
| Top | PPO UL 94 V0 | PPO UL 94 V0 |
| Connection type | Screw terminal | Screw terminal |
| Mounting type | plug-in | plug-in |

Safety relays PNOZ X PSWZ X1P

| Mechanical data | 777949 | 777950 |
|---|--|--|
| Conductor cross section with screw terminals | | |
| 1 core flexible | 0,25 - 2,5 mm ² , 24 - 14 AWG | 0,25 - 2,5 mm ² , 24 - 14 AWG |
| 2 core with the same cross section, flexible with crimp connectors, no plastic sleeve | 0,25 - 1 mm ² , 24 - 16 AWG | 0,25 - 1 mm ² , 24 - 16 AWG |
| 2 core with the same cross section, flexible without crimp connectors or with TWIN crimp connectors | 0,5 - 1,5 mm ² , 24 - 16 AWG | 0,5 - 1,5 mm ² , 24 - 16 AWG |
| Torque setting with screw terminals | 0,6 Nm | 0,6 Nm |
| Dimensions | | |
| Height | 94 mm | 94 mm |
| Width | 45 mm | 45 mm |
| Depth | 121 mm | 121 mm |
| Weight | 325 g | 325 g |

Where standards are undated, the 2014-07 latest editions shall apply.

Order no. 777951 – 777959

See below for more order numbers

| General | 777951 | 777959 |
|--------------------------------------|--|--|
| Approvals | CCC, CE, EAC (Eurasian), TÜV, cULus Listed | CCC, CE, EAC (Eurasian), TÜV, cULus Listed |
| Electrical data | | |
| 777951 | | |
| 777959 | | |
| Supply voltage | | |
| Voltage | 24 - 240 V | 24 - 240 V |
| Kind | AC/DC | AC/DC |
| Voltage tolerance | -15 %/+10 % | -15 %/+10 % |
| Output of external power supply (AC) | 5 VA | 5 VA |
| Output of external power supply (DC) | 3 W | 3 W |
| Frequency range AC | 50 - 60 Hz | 50 - 60 Hz |
| Residual ripple DC | 160 % | 160 % |
| Max. inrush current at UB | 10 A | 10 A |
| Duty cycle | 100 % | 100 % |
| Measuring circuit | | |
| 777951 | | |
| 777959 | | |
| Min. measuring voltage | 0,0 V | 0,0 V |
| Max. measuring voltage | 690 V | 690 V |

Safety relays PNOZ X PSWZ X1P

| Measuring circuit | 777951 | 777959 |
|---|---------------------|---------------------|
| Measuring voltage in accordance with UL | 600 V | 600 V |
| Frequency range | 0 - 3 kHz | 0 - 3 kHz |
| Input resistance | 1.300 kOhm | 1.300 kOhm |
| Switching threshold per channel | | |
| Response value U _{on} (adjustable) | 7,5 - 500 mV | 20 - 500 mV |
| Release value U _{off} | 2 x U _{on} | 2 x U _{on} |
| Inputs | 777951 | 777959 |
| Voltage at | | |
| Feedback loop DC | 24 V | 24 V |
| Current at | | |
| Feedback loop DC | 35 mA | 35 mA |
| Max. inrush current impulse | | |
| Current pulse, feedback loop | 0,12 A | 0,12 A |
| Pulse duration, feedback loop | 0,1 s | 0,1 s |
| Reset input | 777951 | 777959 |
| Low signal | < 5 V | < 5 V |
| High signal | > 15 V | > 15 V |
| Current | 20 mA | 20 mA |
| Semiconductor outputs | 777951 | 777959 |
| Number | 2 | 2 |
| Voltage | 24 V | 24 V |
| Current | 50 mA | 50 mA |
| External supply voltage | 24 V | 24 V |
| Voltage tolerance | -20 %/+20 % | -20 %/+20 % |
| Relay outputs | 777951 | 777959 |
| Number of output contacts | | |
| Safety contacts (N/O), instantaneous | 2 | 2 |
| Auxiliary contacts (N/C) | 1 | 1 |
| Max. short circuit current I _K | 1 kA | 1 kA |
| Utilisation category | | |
| In accordance with the standard | EN 60947-4-1 | EN 60947-4-1 |

Safety relays PNOZ X PSWZ X1P

| Relay outputs | 777951 | 777959 |
|---|----------------|----------------|
| Utilisation category of safety con- tacts | | |
| AC1 at | 240 V | 240 V |
| Min. current | 0,01 A | 0,01 A |
| Max. current | 6 A | 6 A |
| Max. power | 1500 VA | 1500 VA |
| DC1 at | 24 V | 24 V |
| Min. current | 0,01 A | 0,01 A |
| Max. current | 6 A | 6 A |
| Max. power | 150 W | 150 W |
| Utilisation category of auxiliary con- tacts | | |
| AC1 at | 240 V | 240 V |
| Min. current | 0,01 A | 0,01 A |
| Max. current | 6 A | 6 A |
| Max. power | 1500 VA | 1500 VA |
| DC1 at | 24 V | 24 V |
| Min. current | 0,01 A | 0,01 A |
| Max. current | 6 A | 6 A |
| Max. power | 150 W | 150 W |
| Utilisation category | | |
| In accordance with the standard | EN 60947-5-1 | EN 60947-5-1 |
| Utilisation category of safety con- tacts | | |
| AC15 at | 230 V | 230 V |
| Max. current | 3 A | 3 A |
| DC13 (6 cycles/min) at | 24 V | 24 V |
| Max. current | 4 A | 4 A |
| Utilisation category of auxiliary con- tacts | | |
| AC15 at | 230 V | 230 V |
| Max. current | 3 A | 3 A |
| DC13 (6 cycles/min) at | 24 V | 24 V |
| Max. current | 4 A | 4 A |
| Utilisation category in accordance with UL | | |
| Voltage | 240 V AC G. P. | 240 V AC G. P. |
| With current | 6 A | 6 A |

Safety relays PNOZ X PSWZ X1P

| Relay outputs | 777951 | 777959 |
|--|---------------------------|---------------------------|
| External contact fuse protection, safety contacts | | |
| In accordance with the standard | EN 60947-5-1 | EN 60947-5-1 |
| Max. melting integral | 66 A²s | 66 A²s |
| Blow-out fuse, quick | 6 A | 6 A |
| Blow-out fuse, slow | 4 A | 4 A |
| Blow-out fuse, gG | 6 A | 6 A |
| Circuit breaker 24V AC/DC, characteristic B/C | 4 A | 4 A |
| External contact fuse protection, auxiliary contacts | | |
| Max. melting integral | 66 A²s | 66 A²s |
| Blow-out fuse, quick | 6 A | 6 A |
| Blow-out fuse, slow | 4 A | 4 A |
| Blow-out fuse, gG | 6 A | 6 A |
| Circuit breaker 24 V AC/DC, characteristic B/C | 4 A | 4 A |
| Conventional thermal current | 6 A | 6 A |
| Contact material | AgCuNi + 0,2 µm Au | AgCuNi + 0,2 µm Au |
| Conventional thermal current while loading several contacts | 777951 | 777959 |
| I _{th} per contact at UB DC; AC1: 240 V, DC1: 24 V | | |
| Conv. therm. current with 1 contact | 6 A | 6 A |
| Conv. therm. current with 2 contacts | 4 A | 4 A |
| Times | 777951 | 777959 |
| Delay-on de-energisation | | |
| After motor on max. | 170 ms | 170 ms |
| Max. switch-on delay | | |
| After motor standstill max. | 1.500 ms | 1.500 ms |
| After power on max. | 2.200 ms | 2.200 ms |
| Recovery time at max. switching frequency 1/s | | |
| After motor on | 2.200 ms | 2.200 ms |
| Supply interruption before de-energisation | 20 ms | 20 ms |
| Simultaneity, channel 1 and 2 max. | 7 s | 7 s |
| Environmental data | 777951 | 777959 |
| Climatic suitability | EN 60068-2-78 | EN 60068-2-78 |

Safety relays PNOZ X PSWZ X1P

| Environmental data | 777951 | 777959 |
|--------------------------------------|---|---|
| Ambient temperature | | |
| Temperature range | -10 - 55 °C | -10 - 55 °C |
| Storage temperature | | |
| Temperature range | -40 - 85 °C | -40 - 85 °C |
| Climatic suitability | | |
| Humidity | 93 % r. h. at 40 °C | 93 % r. h. at 40 °C |
| Condensation during operation | Not permitted | Short-term |
| EMC | EN 60947-5-1, EN 61000-6-2, EN 61000-6-4, EN 61326-3-1 | EN 60947-5-1, EN 61000-6-2, EN 61000-6-4, EN 61326-3-1 |
| Vibration | | |
| In accordance with the standard | EN 60068-2-6 | EN 60068-2-6 |
| Frequency | 10 - 55 Hz | 10 - 55 Hz |
| Amplitude | 0,35 mm | 0,35 mm |
| Airgap creepage | | |
| In accordance with the standard | EN 60947-1 | EN 60947-1 |
| Overvoltage category | III / II | III / II |
| Pollution degree | 2 | 2 |
| Rated insulation voltage | 690 V | 690 V |
| Rated impulse withstand voltage | 6 kV | 6 kV |
| Protection type | | |
| Mounting area (e.g. control cabinet) | IP54 | IP54 |
| Housing | IP40 | IP40 |
| Terminals | IP20 | IP20 |
| Mechanical data | 777951 | 777959 |
| Mounting position | Any | Any |
| Mechanical life | 10,000,000 cycles | 10,000,000 cycles |
| Material | | |
| Bottom | PPO UL 94 V0 | PPO UL 94 V0 |
| Front | ABS UL 94 V0 | ABS UL 94 V0 |
| Top | PPO UL 94 V0 | PPO UL 94 V0 |
| Connection type | Screw terminal | Screw terminal |
| Mounting type | plug-in | plug-in |

Safety relays PNOZ X PSWZ X1P

| Mechanical data | 777951 | 777959 |
|---|--|--|
| Conductor cross section with screw terminals | | |
| 1 core flexible | 0,25 - 2,5 mm ² , 24 - 14 AWG | 0,25 - 2,5 mm ² , 24 - 14 AWG |
| 2 core with the same cross section, flexible with crimp connectors, no plastic sleeve | 0,25 - 1 mm ² , 24 - 16 AWG | 0,25 - 1 mm ² , 24 - 16 AWG |
| 2 core with the same cross section, flexible without crimp connectors or with TWIN crimp connectors | 0,5 - 1,5 mm ² , 24 - 16 AWG | 0,5 - 1,5 mm ² , 24 - 16 AWG |
| Torque setting with screw terminals | 0,6 Nm | 0,6 Nm |
| Dimensions | | |
| Height | 94 mm | 94 mm |
| Width | 45 mm | 45 mm |
| Depth | 121 mm | 121 mm |
| Weight | 325 g | 325 g |

Where standards are undated, the 2014-07 latest editions shall apply.

Order no. 787949 – 787951

| General | 787949 | 787950 | 787951 |
|---|--|--|--|
| Approvals | CCC, CE, EAC (Eurasian), TÜV, cULus Listed | CCC, CE, EAC (Eurasian), TÜV, cULus Listed | CCC, CE, EAC (Eurasian), TÜV, cULus Listed |
| Electrical data | 787949 | 787950 | 787951 |
| Supply voltage | | | |
| Voltage | 24 - 240 V | 24 - 240 V | 24 - 240 V |
| Kind | AC/DC | AC/DC | AC/DC |
| Voltage tolerance | -15 %/+10 % | -15 %/+10 % | -15 %/+10 % |
| Output of external power supply (AC) | 5 VA | 5 VA | 5 VA |
| Output of external power supply (DC) | 3 W | 3 W | 3 W |
| Frequency range AC | 50 - 60 Hz | 50 - 60 Hz | 50 - 60 Hz |
| Residual ripple DC | 160 % | 160 % | 160 % |
| Max. inrush current at UB | 10 A | 10 A | 10 A |
| Duty cycle | 100 % | 100 % | 100 % |
| Measuring circuit | 787949 | 787950 | 787951 |
| Min. measuring voltage | 0,0 V | 0,0 V | 0,0 V |
| Max. measuring voltage | 690 V | 690 V | 690 V |
| Measuring voltage in accordance with UL | 600 V | 600 V | 600 V |

Safety relays PNOZ X PSWZ X1P

| Measuring circuit | 787949 | 787950 | 787951 |
|---|---------------------|---------------------|---------------------|
| Frequency range | 0 - 3 kHz | 0 - 3 kHz | 0 - 3 kHz |
| Input resistance | 1.300 kOhm | 1.300 kOhm | 1.300 kOhm |
| Switching threshold per channel | | | |
| Response value U _{on} (adjustable) | 20 - 500 mV | 120 - 3000 mV | 7,5 - 500 mV |
| Release value U _{off} | 2 x U _{on} | 2 x U _{on} | 2 x U _{on} |
| Inputs | 787949 | 787950 | 787951 |
| Voltage at | | | |
| Feedback loop DC | 24 V | 24 V | 24 V |
| Current at | | | |
| Feedback loop DC | 35 mA | 35 mA | 35 mA |
| Max. inrush current impulse | | | |
| Current pulse, feedback loop | 0,12 A | 0,12 A | 0,12 A |
| Pulse duration, feedback loop | 0,1 s | 0,1 s | 0,1 s |
| Reset input | 787949 | 787950 | 787951 |
| Low signal | < 5 V | < 5 V | < 5 V |
| High signal | > 15 V | > 15 V | > 15 V |
| Current | 20 mA | 20 mA | 20 mA |
| Semiconductor outputs | 787949 | 787950 | 787951 |
| Number | 2 | 2 | 2 |
| Voltage | 24 V | 24 V | 24 V |
| Current | 50 mA | 50 mA | 50 mA |
| External supply voltage | 24 V | 24 V | 24 V |
| Voltage tolerance | -20 %/+20 % | -20 %/+20 % | -20 %/+20 % |
| Relay outputs | 787949 | 787950 | 787951 |
| Number of output contacts | | | |
| Safety contacts (N/O), instantaneous | 2 | 2 | 2 |
| Auxiliary contacts (N/C) | 1 | 1 | 1 |
| Max. short circuit current I _K | 1 kA | 1 kA | 1 kA |
| Utilisation category | | | |
| In accordance with the standard | EN 60947-4-1 | EN 60947-4-1 | EN 60947-4-1 |

Safety relays PNOZ X PSWZ X1P

| Relay outputs | 787949 | 787950 | 787951 |
|--|----------------|----------------|----------------|
| Utilisation category of safety contacts | | | |
| AC1 at | 240 V | 240 V | 240 V |
| Min. current | 0,01 A | 0,01 A | 0,01 A |
| Max. current | 6 A | 6 A | 6 A |
| Max. power | 1500 VA | 1500 VA | 1500 VA |
| DC1 at | 24 V | 24 V | 24 V |
| Min. current | 0,01 A | 0,01 A | 0,01 A |
| Max. current | 6 A | 6 A | 6 A |
| Max. power | 150 W | 150 W | 150 W |
| Utilisation category of auxiliary contacts | | | |
| AC1 at | 240 V | 240 V | 240 V |
| Min. current | 0,01 A | 0,01 A | 0,01 A |
| Max. current | 6 A | 6 A | 6 A |
| Max. power | 1500 VA | 1500 VA | 1500 VA |
| DC1 at | 24 V | 24 V | 24 V |
| Min. current | 0,01 A | 0,01 A | 0,01 A |
| Max. current | 6 A | 6 A | 6 A |
| Max. power | 150 W | 150 W | 150 W |
| Utilisation category | | | |
| In accordance with the standard | EN 60947-5-1 | EN 60947-5-1 | EN 60947-5-1 |
| Utilisation category of safety contacts | | | |
| AC15 at | 230 V | 230 V | 230 V |
| Max. current | 3 A | 3 A | 3 A |
| DC13 (6 cycles/min) at | 24 V | 24 V | 24 V |
| Max. current | 4 A | 4 A | 4 A |
| Utilisation category of auxiliary contacts | | | |
| AC15 at | 230 V | 230 V | 230 V |
| Max. current | 3 A | 3 A | 3 A |
| DC13 (6 cycles/min) at | 24 V | 24 V | 24 V |
| Max. current | 4 A | 4 A | 4 A |
| Utilisation category in accordance with UL | | | |
| Voltage | 240 V AC G. P. | 240 V AC G. P. | 240 V AC G. P. |
| With current | 6 A | 6 A | 6 A |

Safety relays PNOZ X PSWZ X1P

| Relay outputs | 787949 | 787950 | 787951 |
|--|---------------------|---------------------|---------------------|
| External contact fuse protection, safety contacts | | | |
| In accordance with the standard | EN 60947-5-1 | EN 60947-5-1 | EN 60947-5-1 |
| Max. melting integral | 66 A ² s | 66 A ² s | 66 A ² s |
| Blow-out fuse, quick | 6 A | 6 A | 6 A |
| Blow-out fuse, slow | 4 A | 4 A | 4 A |
| Blow-out fuse, gG | 6 A | 6 A | 6 A |
| Circuit breaker 24V AC/DC, characteristic B/C | 4 A | 4 A | 4 A |
| External contact fuse protection, auxiliary contacts | | | |
| Max. melting integral | 66 A ² s | 66 A ² s | 66 A ² s |
| Blow-out fuse, quick | 6 A | 6 A | 6 A |
| Blow-out fuse, slow | 4 A | 4 A | 4 A |
| Blow-out fuse, gG | 6 A | 6 A | 6 A |
| Circuit breaker 24 V AC/DC, characteristic B/C | 4 A | 4 A | 4 A |
| Conventional thermal current | 6 A | 6 A | 6 A |
| Contact material | AgCuNi + 0,2 µm Au | AgCuNi + 0,2 µm Au | AgCuNi + 0,2 µm Au |
| Conventional thermal current while loading several contacts | 787949 | 787950 | 787951 |
| I _{th} per contact at UB DC; AC1: 240 V, DC1: 24 V | | | |
| Conv. therm. current with 1 contact | 6 A | 6 A | 6 A |
| Conv. therm. current with 2 contacts | 4 A | 4 A | 4 A |
| Times | 787949 | 787950 | 787951 |
| Delay-on de-energisation | | | |
| After motor on max. | 170 ms | 170 ms | 170 ms |
| Max. switch-on delay | | | |
| After motor standstill max. | 1.500 ms | 1.500 ms | 1.500 ms |
| After power on max. | 2.200 ms | 2.200 ms | 2.200 ms |
| Recovery time at max. switching frequency 1/s | | | |
| After motor on | 2.200 ms | 2.200 ms | 2.200 ms |
| Supply interruption before de-energisation | 20 ms | 20 ms | 20 ms |

Safety relays PNOZ X PSWZ X1P

| Times | 787949 | 787950 | 787951 |
|--------------------------------------|--|--|--|
| Simultaneity, channel 1 and 2 max. | 7 s | 7 s | 7 s |
| Environmental data | 787949 | 787950 | 787951 |
| Climatic suitability | EN 60068-2-78 | EN 60068-2-78 | EN 60068-2-78 |
| Ambient temperature | | | |
| Temperature range | -10 - 55 °C | -10 - 55 °C | -10 - 55 °C |
| Storage temperature | | | |
| Temperature range | -40 - 85 °C | -40 - 85 °C | -40 - 85 °C |
| Climatic suitability | | | |
| Humidity | 93 % r. h. at 40 °C | 93 % r. h. at 40 °C | 93 % r. h. at 40 °C |
| Condensation during operation | Not permitted | Not permitted | Not permitted |
| EMC | EN 60947-5-1, EN 61000-6-2, EN 61000-6-4, EN 61326-3-1 | EN 60947-5-1, EN 61000-6-2, EN 61000-6-4, EN 61326-3-1 | EN 60947-5-1, EN 61000-6-2, EN 61000-6-4, EN 61326-3-1 |
| Vibration | | | |
| In accordance with the standard | EN 60068-2-6 | EN 60068-2-6 | EN 60068-2-6 |
| Frequency | 10 - 55 Hz | 10 - 55 Hz | 10 - 55 Hz |
| Amplitude | 0,35 mm | 0,35 mm | 0,35 mm |
| Airgap creepage | | | |
| In accordance with the standard | EN 60947-1 | EN 60947-1 | EN 60947-1 |
| Overvoltage category | III / II | III / II | III / II |
| Pollution degree | 2 | 2 | 2 |
| Rated insulation voltage | 690 V | 690 V | 690 V |
| Rated impulse withstand voltage | 6 kV | 6 kV | 6 kV |
| Protection type | | | |
| Mounting area (e.g. control cabinet) | IP54 | IP54 | IP54 |
| Housing | IP40 | IP40 | IP40 |
| Terminals | IP20 | IP20 | IP20 |
| Mechanical data | 787949 | 787950 | 787951 |
| Mounting position | Any | Any | Any |
| Mechanical life | 10,000,000 cycles | 10,000,000 cycles | 10,000,000 cycles |
| Material | | | |
| Bottom | PPO UL 94 V0 | PPO UL 94 V0 | PPO UL 94 V0 |
| Front | ABS UL 94 V0 | ABS UL 94 V0 | ABS UL 94 V0 |
| Top | PPO UL 94 V0 | PPO UL 94 V0 | PPO UL 94 V0 |
| Connection type | Cage clamp terminal | Cage clamp terminal | Cage clamp terminal |
| Mounting type | plug-in | plug-in | plug-in |

Safety relays PNOZ X PSWZ X1P

| Mechanical data | 787949 | 787950 | 787951 |
|---|---|---|---|
| Conductor cross section with spring-loaded terminals: Flexible with/without crimp connector | 0,2 - 1,5 mm ² , 24 - 16 AWG | 0,2 - 1,5 mm ² , 24 - 16 AWG | 0,2 - 1,5 mm ² , 24 - 16 AWG |
| Spring-loaded terminals: Terminal points per connection | 2 | 2 | 2 |
| Stripping length with spring-loaded terminals | 8 mm | 8 mm | 8 mm |
| Dimensions | | | |
| Height | 101 mm | 101 mm | 101 mm |
| Width | 45 mm | 45 mm | 45 mm |
| Depth | 121 mm | 121 mm | 121 mm |
| Weight | 325 g | 325 g | 325 g |

Where standards are undated, the 2014-07 latest editions shall apply.

Safety characteristic data

| Operating Mode | EN ISO 13849-1: 2015 | EN ISO 13849-1: 2015 | EN 62061 SIL CL | EN 62061 PFH _D [1/h] | IEC 61511 SIL | IEC 61511 PFD | EN ISO 13849-1: 2015 T _M [year] |
|----------------|----------------------|----------------------|-----------------|---------------------------------|---------------|---------------|--|
| – | PL e | Cat. 4 | SIL CL 3 | 6,23E-09 | SIL 3 | 6,47E-05 | 20 |

All the units used within a safety function must be considered when calculating the safety characteristic data.

Supplementary data

The PFH value depends on the switching frequency and the load on the relay output. If the service life graphs are not accessible, the stated PFH value can be used irrespective of the switching frequency and the load, as the PFH value already considers the relay's B10d value as well as the failure rates of the other components.

Safety relays PNOZ X PSWZ X1P

Service life graph

The service life graphs indicate the number of cycles from which failures due to wear must be expected. The wear is mainly caused by the electrical load; the mechanical load is negligible.

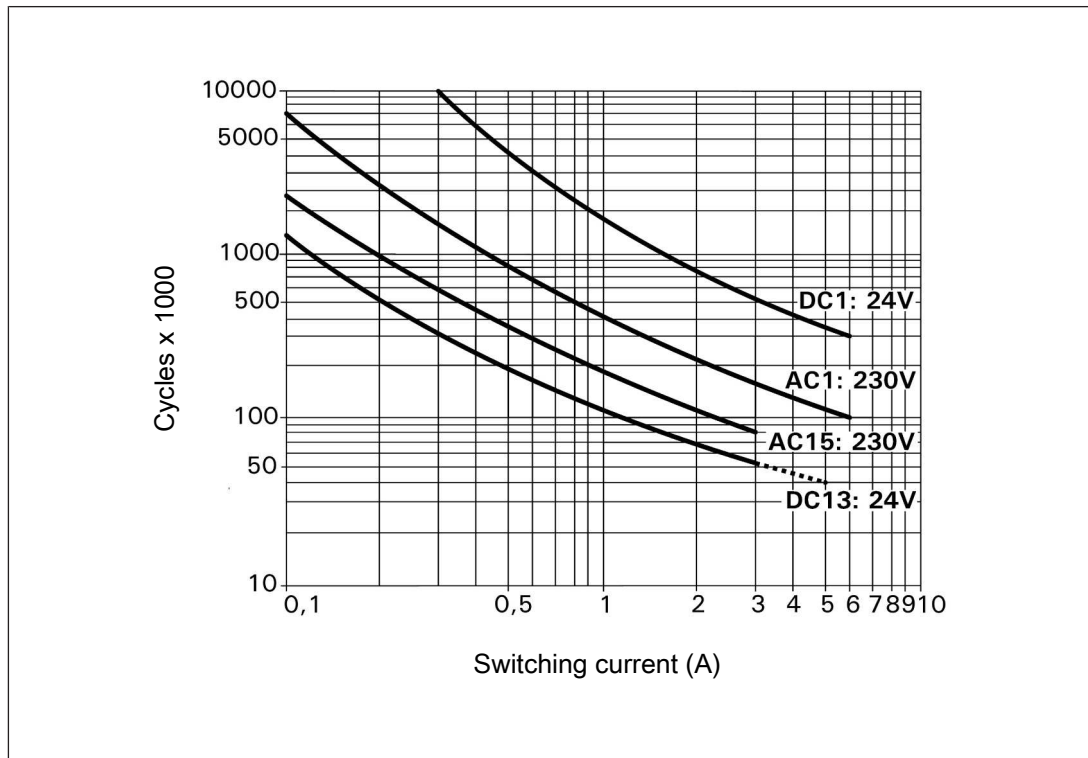

Fig.: Service life graphs at 24 VDC and 230 VAC

Safety relays PNOZ X PSWZ X1P

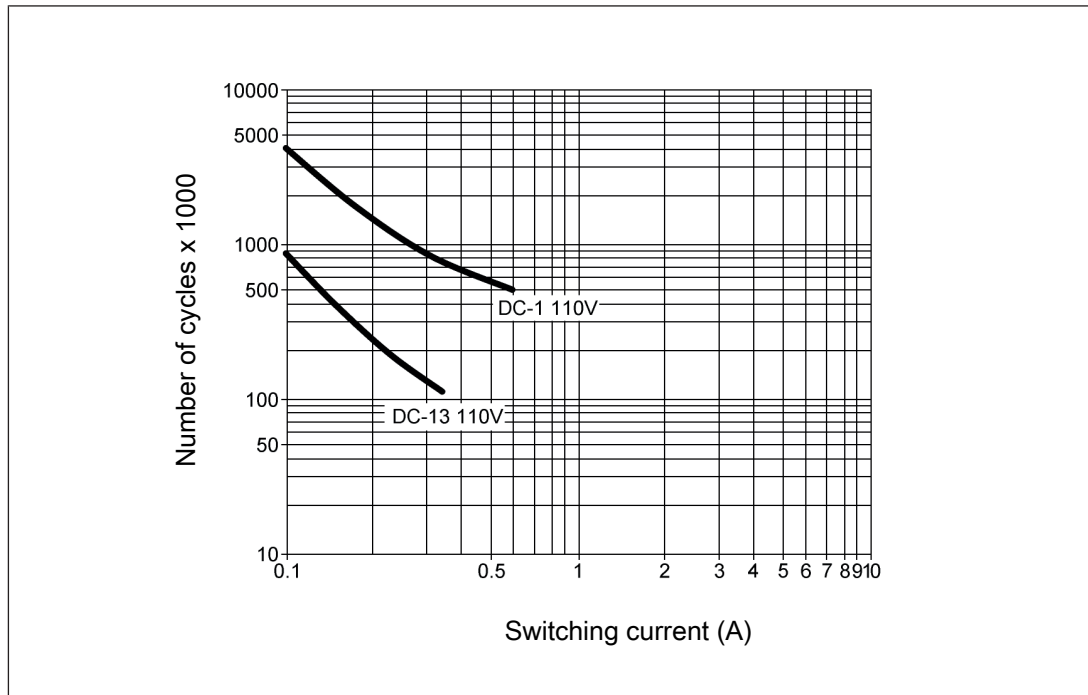

Fig.: Service life graphs at 110 VDC

Example

- ▶ Inductive load: 0.2 A
- ▶ Utilisation category: AC15
- ▶ Contact service life: 1 000 000 cycles

Provided the application to be implemented requires fewer than 1 000 000 cycles, the PFH value (see [Technical details \[527\]](#)) can be used in the calculation.

To increase the service life, sufficient spark suppression must be provided on all relay contacts. With capacitive loads, any power surges that occur must be noted. With DC contactors, use flywheel diodes for spark suppression.

Safety relays PNOZ X PSWZ X1P

Order reference

| Type | Features | Connection type | Order no. |
|------------------------------|---|------------------------|-----------|
| PSWZ X1P C | 24 - 240 V AC/DC; 0,02 - 0,5 V; U_{on} : 20 - 500 mV | Spring-loaded terminal | 787 949 |
| PSWZ X1P | 24 - 240 V AC/DC; 0,02 - 0,5 V; U_{on} : 20 - 500 mV | Screw terminals | 777 949 |
| PSWZ X1P C | 24 - 240 V AC/DC; 0,12 - 3 V; U_{on} : 120 - 3000 mV | Spring-loaded terminal | 787 950 |
| PSWZ X1P | 24 - 240 V AC/DC; 0,12 - 3 V; U_{on} : 120 - 3000 mV | Screw terminals | 777 950 |
| PSWZ X1P C | 24 - 240 V AC/DC; 0,0075 - 0,5 V; U_{on} : 7.5 - 500 mV | Spring-loaded terminal | 787 951 |
| PSWZ X1P | 24 - 240 V AC/DC; 0,0075 - 0,5 V; U_{on} : 7.5 - 500 mV | Screw terminals | 777 951 |
| PSWZ X1P (coated version) | 24 - 240 V AC/DC; 0,02 - 0,5 V; U_{on} : 20 - 500 mV | Screw terminals | 777 959 |

Selection guide: Determine remanence voltage

The remanence voltage has to be within the response range of the device.

Safety relays PNOZsigma

Safety relays PNOZsigma

| Contents | Page |
|-----------------|-------------|
| PNOZ s1 | 548 |
| PNOZ s2 | 559 |
| PNOZ s3 | 573 |
| PNOZ s4 | 588 |
| PNOZ s4.1 | 614 |
| PNOZ s5 | 634 |
| PNOZ s6 | 661 |
| PNOZ s6.1 | 682 |
| PNOZ s7 | 703 |
| PNOZ s7.1 | 716 |
| PNOZ s7.2 | 730 |
| PNOZ s8 | 742 |
| PNOZ s9 | 752 |
| PNOZ s10 | 769 |
| PNOZ s11 | 781 |
| PNOZ s20 | 792 |
| PNOZ s22 | 801 |
| PNOZ s30 | 810 |
| PNOZ s50 | 893 |

Safety relays PNOZsigma PNOZ s1



Unit features

- ▶ Relay outputs:
 - 2 safety contacts (N/O), instantaneous
- ▶ 1 semiconductor output
- ▶ Connection options for:
 - E-STOP pushbutton
 - Safety gate limit switch
 - Start button
- ▶ A connector can be used to connect 1 PNOZsigma contact expansion module
- ▶ LED indicator for:
 - Supply voltage
 - Input status, channel 1
 - Input status, channel 2
 - Switch status of the safety contacts
 - Start circuit
 - Errors
- ▶ Plug-in connection terminals (either spring-loaded terminal or screw terminal)
- ▶ See order reference for unit types

Safety relays PNOZsigma PNOZ s1

Block diagram/terminal configuration

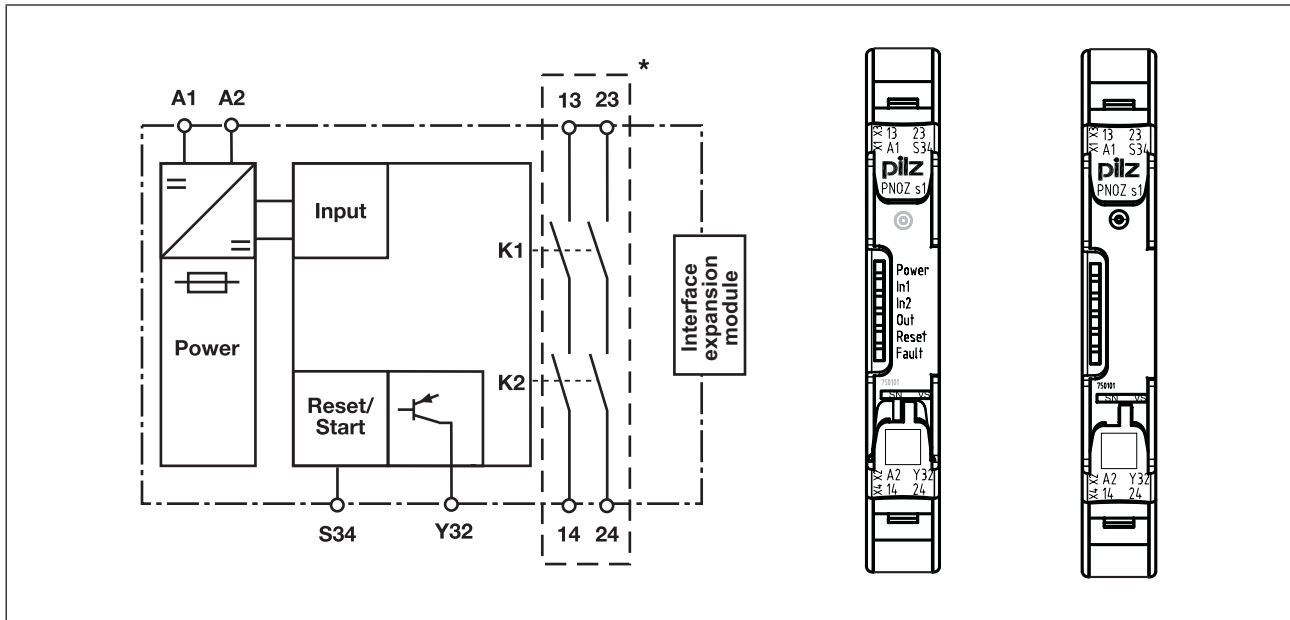

Fig.: Centre: Front view with cover, right: Front view without cover

*Insulation between the non-marked area and the relay contacts: Basic insulation (over-voltage category III), Protective separation (overvoltage category II)

Function description

- ▶ Single-channel operation: No redundancy in the input circuit, earth faults in the start and input circuit are detected.
- ▶ Automatic start: Unit is active once the input circuit has been closed.
- ▶ Manual start: Unit is active once the input circuit and the start circuit are closed.
- ▶ Increase in the number of available instantaneous safety contacts by connecting contact expander modules or external contactors/relays;
A connector can be used to connect 1 PNOZsigma contact expander module.

Safety relays PNOZsigma PNOZ s1

Timing diagram

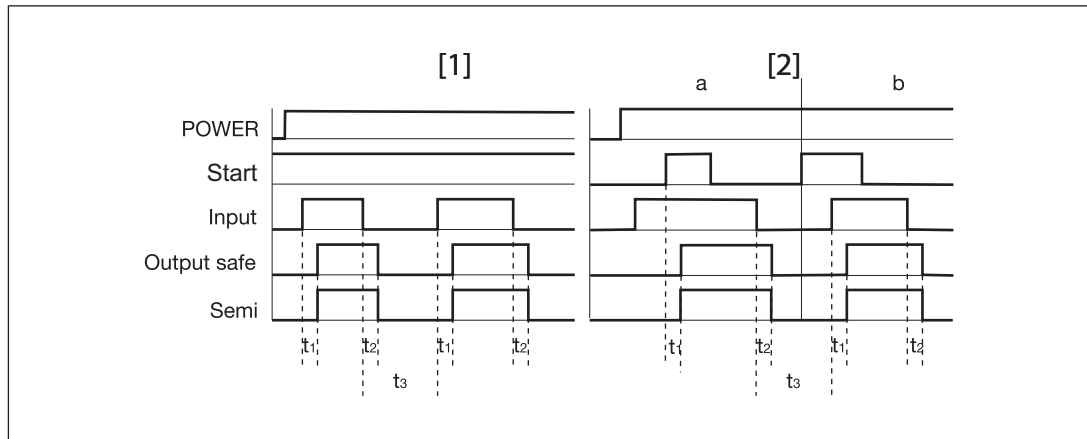

Legend

- ▶ POWER: Supply voltage
- ▶ Start: Start circuit
- ▶ Input: Input circuits
- ▶ Output safe: Safety contacts
- ▶ Semi: Semiconductor output
- ▶ [1]: Automatic start
- ▶ [2]: Manual start
- ▶ a: Input circuit closes before start circuit
- ▶ b: Start circuit closes before input circuit
- ▶ t₁: Switch-on delay
- ▶ t₂: Delay-on de-energisation
- ▶ t₃: Recovery time

Installation

Install base unit without contact expansion module:

- ▶ Ensure that the plug terminator is inserted at the side of the unit.

Connect base unit and PNOZsigma contact expansion module:

- ▶ Remove the plug terminator at the side of the base unit and at the contact expansion module.
- ▶ Connect the base unit and the contact expansion module to the supplied connector before mounting the units to the DIN rail.

Installation in control cabinet

- ▶ The safety relay should be installed in a control cabinet with a protection type of at least IP54.
- ▶ Use the notch on the rear of the unit to attach it to a DIN rail (35 mm).

Safety relays PNOZsigma PNOZ s1

- ▶ When installed vertically: Secure the unit by using a fixing element (e.g. retaining bracket or end angle).
- ▶ Push the device upwards or downwards before lifting it from the DIN rail.

Wiring

Please note:

- ▶ Information given in the "[Technical details \[554\]](#)" must be followed.
- ▶ Outputs 13-14 and 23-24 are safety contacts, the semiconductor output Y32 is an auxiliary output (e.g. for display).
- ▶ Semiconductor output Y32 should **not** be used for safety circuits!
- ▶ To prevent contact welding, a fuse should be connected before the output contacts (see [Technical details \[554\]](#)).
- ▶ Calculation of the max. cable length l_{\max} in the input circuit:

$$l_{\max} = \frac{R_{l_{\max}}}{R_l / \text{km}}$$

$R_{l_{\max}}$ = max. overall cable resistance (see [Technical details \[554\]](#))

R_l / km = cable resistance/km

- ▶ Use copper wire that can withstand 60/75 °C.
- ▶ Sufficient fuse protection must be provided on all output contacts with capacitive and inductive loads.
- ▶ Ensure the wiring and EMC requirements of IEC 60204-1 are met.
- ▶ The power supply must comply with the regulations for extra low voltages with protective electrical separation (SELV, PELV) in accordance with VDE 0100, Part 410.

Safety relays PNOZsigma PNOZ s1

Preparing for operation

| Supply voltage | AC | DC |
|---|----------------|---------------|
| | | |
| Input circuit | Single-channel | Dual-channel |
| E-STOP without detection of shorts across contacts | | |
| Safety gate without detection of shorts across contacts | | |
| Start circuit/feedback loop | Start circuit | Feedback loop |
| Automatic start | | |
| Manual start | | |

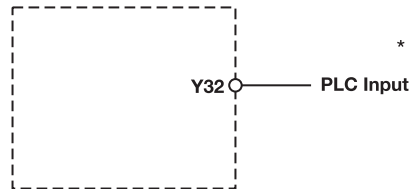

Safety relays PNOZsigma PNOZ s1

Semiconductor output



*Connect together the 0V connections on all the external power supplies

Key

- ▶ S1: E-STOP pushbutton
- ▶ S3: Start button
- ▶ ↑↑: Switch operated
- ▶ : Gate open
- ▶ : Gate closed

Dimensions in mm

*with spring-loaded terminals

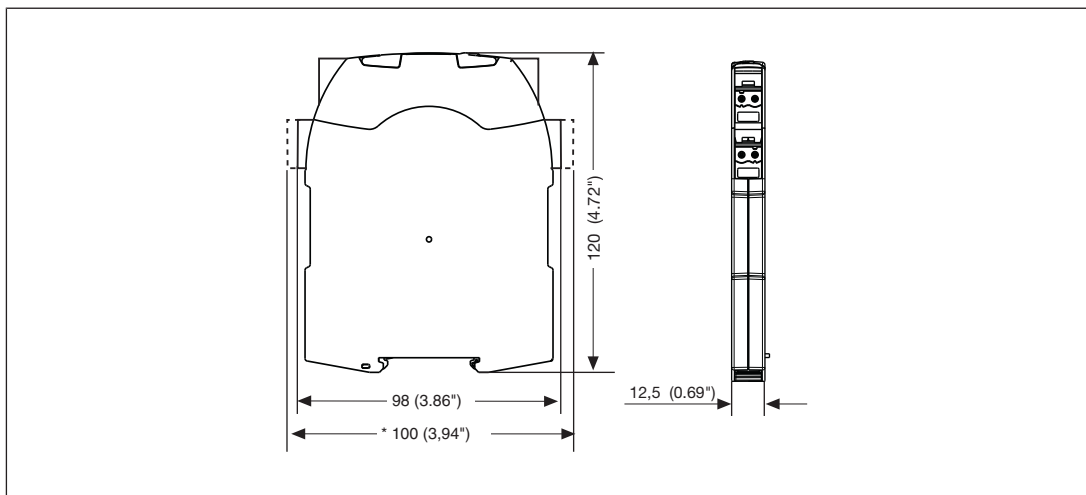

Safety relays PNOZsigma PNOZ s1

Technical Details

| General | 750101 | 751101 |
|--|--|--|
| Approvals | CCC, CE, EAC (Eurasian), KOSHA, TÜV, cULus Listed | CCC, CE, EAC (Eurasian), KOSHA, TÜV, cULus Listed |
| Electrical data | 750101 | 751101 |
| Supply voltage | | |
| Voltage | 24 V | 24 V |
| Kind | DC | DC |
| Voltage tolerance | -15 %/+10 % | -15 %/+10 % |
| Output of external power supply (DC) | 2 W | 2 W |
| Residual ripple DC | 20 % | 20 % |
| Duty cycle | 100 % | 100 % |
| Inputs | 750101 | 751101 |
| Number | 1 | 1 |
| Voltage at | | |
| Input circuit DC | 24 V | 24 V |
| Start circuit DC | 24 V | 24 V |
| Feedback loop DC | 24 V | 24 V |
| Current at | | |
| Input circuit DC | 60 mA | 60 mA |
| Start circuit DC | 20 mA | 20 mA |
| Feedback loop DC | 20 mA | 20 mA |
| Max. inrush current impulse | | |
| Current pulse, input circuit | 1 A | 1 A |
| Pulse duration, input circuit | 5 ms | 5 ms |
| Current pulse, feedback loop | 0,2 A | 0,2 A |
| Pulse duration, feedback loop | 0,5 ms | 0,5 ms |
| Current pulse, start circuit | 0,2 A | 0,2 A |
| Pulse duration, start circuit | 0,5 ms | 0,5 ms |
| Max. overall cable resistance R _{I-max} | | |
| Single-channel at UB DC | 30 Ohm | 30 Ohm |
| Semiconductor outputs | 750101 | 751101 |
| Number | 1 | 1 |
| Voltage | 24 V | 24 V |
| Current | 20 mA | 20 mA |
| Relay outputs | 750101 | 751101 |
| Number of output contacts | | |
| Safety contacts (N/O), instantaneous | 2 | 2 |

Safety relays PNOZsigma PNOZ s1

| Relay outputs | 750101 | 751101 |
|---|----------------|----------------|
| Max. short circuit current IK | 1 kA | 1 kA |
| Utilisation category | | |
| In accordance with the standard | EN 60947-4-1 | EN 60947-4-1 |
| Utilisation category of safety contacts | | |
| AC1 at | 240 V | 240 V |
| Min. current | 0,02 A | 0,02 A |
| Max. current | 3 A | 3 A |
| Max. power | 720 VA | 720 VA |
| DC1 at | 24 V | 24 V |
| Min. current | 0,02 A | 0,02 A |
| Max. current | 3 A | 3 A |
| Max. power | 72 W | 72 W |
| Utilisation category | | |
| In accordance with the standard | EN 60947-5-1 | EN 60947-5-1 |
| Utilisation category of safety contacts | | |
| AC15 at | 230 V | 230 V |
| Max. current | 1,5 A | 1,5 A |
| DC13 (6 cycles/min) at | 24 V | 24 V |
| Max. current | 1,5 A | 1,5 A |
| Utilisation category in accordance with UL | | |
| Voltage | 240 V AC G. P. | 240 V AC G. P. |
| With current | 3 A | 3 A |
| Voltage | 24 V DC G. P. | 24 V DC G. P. |
| With current | 3 A | 3 A |
| Pilot Duty | B300, R300 | B300, R300 |
| External contact fuse protection, safety contacts | | |
| In accordance with the standard | EN 60947-5-1 | EN 60947-5-1 |
| Blow-out fuse, quick | 4 A | 4 A |
| Blow-out fuse, slow | 2 A | 2 A |
| Blow-out fuse, gG | 4 A | 4 A |
| Circuit breaker 24V AC/DC, characteristic B/C | 2 A | 2 A |
| Conventional thermal current | 3 A | 3 A |
| Contact material | AgSnO2 | AgSnO2 |

Safety relays PNOZsigma PNOZ s1

| Times | 750101 | 751101 |
|---|--|--|
| Switch-on delay | | |
| With automatic start typ. | 100 ms | 100 ms |
| With automatic start max. | 150 ms | 150 ms |
| With automatic start after power on typ. | 100 ms | 100 ms |
| With automatic start after power on max. | 150 ms | 150 ms |
| With manual start typ. | 50 ms | 50 ms |
| With manual start max. | 60 ms | 60 ms |
| Delay-on de-energisation | | |
| With E-STOP typ. | 30 ms | 30 ms |
| With E-STOP max. | 40 ms | 40 ms |
| With power failure typ. | 30 ms | 30 ms |
| With power failure max. | 40 ms | 40 ms |
| Recovery time at max. switching frequency 1/s | | |
| After E-STOP | 100 ms | 100 ms |
| After power failure | 100 ms | 100 ms |
| Supply interruption before de-energisation | | |
| | 10 ms | 10 ms |
| Environmental data | | |
| | 750101 | 751101 |
| Climatic suitability | EN 60068-2-78 | EN 60068-2-78 |
| Ambient temperature | | |
| Temperature range | -10 - 55 °C | -10 - 55 °C |
| Storage temperature | | |
| Temperature range | -40 - 85 °C | -40 - 85 °C |
| Climatic suitability | | |
| Humidity | 93 % r. h. at 40 °C | 93 % r. h. at 40 °C |
| Condensation during operation | | |
| | Not permitted | Not permitted |
| EMC | | |
| | EN 60947-5-1, EN 61000-6-2, EN 61000-6-4, EN 61326-3-1 | EN 60947-5-1, EN 61000-6-2, EN 61000-6-4, EN 61326-3-1 |
| Vibration | | |
| In accordance with the standard | EN 60068-2-6 | EN 60068-2-6 |
| Frequency | 10 - 55 Hz | 10 - 55 Hz |
| Amplitude | 0,35 mm | 0,35 mm |
| Airgap creepage | | |
| In accordance with the standard | EN 60947-1 | EN 60947-1 |
| Overvoltage category | III / II | III / II |
| Pollution degree | 2 | 2 |
| Rated insulation voltage | | |
| | 250 V | 250 V |
| Rated impulse withstand voltage | | |
| | 4 kV | 4 kV |

Safety relays PNOZsigma PNOZ s1

| Environmental data | 750101 | 751101 |
|---|---|--|
| Protection type | | |
| Mounting area (e.g. control cabinet) | IP54 | IP54 |
| Housing | IP40 | IP40 |
| Terminals | IP20 | IP20 |
| Mechanical data | 750101 | 751101 |
| Mounting position | Any | Any |
| Mechanical life | 5,000,000 cycles | 5,000,000 cycles |
| Material | | |
| Bottom | PC | PC |
| Front | PC | PC |
| Top | PC | PC |
| Connection type | Screw terminal | Spring-loaded terminal |
| Mounting type | plug-in | plug-in |
| Conductor cross section with screw terminals | | |
| 1 core flexible | 0,25 - 2,5 mm², 24 - 12 AWG | – |
| 2 core with the same cross section, flexible with crimp connectors, no plastic sleeve | 0,25 - 1 mm², 24 - 16 AWG | – |
| 2 core with the same cross section, flexible without crimp connectors or with TWIN crimp connectors | 0,2 - 1,5 mm², 24 - 16 AWG | – |
| Torque setting with screw terminals | 0,5 Nm | – |
| Conductor cross section with spring-loaded terminals: Flexible with/without crimp connector | – | 0,2 - 2,5 mm², 24 - 12 AWG |
| Spring-loaded terminals: Terminal points per connection | – | 2 |
| Stripping length with spring-loaded terminals | – | 9 mm |
| Dimensions | | |
| Height | 98 mm | 100 mm |
| Width | 12,5 mm | 12,5 mm |
| Depth | 120 mm | 120 mm |
| Weight | 105 g | 105 g |

Where standards are undated, the 2014-07 latest editions shall apply.

Safety relays PNOZsigma PNOZ s1

Safety characteristic data

| | | | | | | | |
|-----------------------|-----------------------------|-----------------------------|------------------------|---------------------------------------|----------------------|----------------------|-----------------------------|
| Operating Mode | EN ISO 13849-1: 2015 | EN ISO 13849-1: 2015 | EN 62061 SIL CL | EN 62061 PFH_D [1/h] | IEC 61511 SIL | IEC 61511 PFD | EN ISO 13849-1: 2015 |
| | PL | Category | | | | | T_M [year] |

Safety contacts, instantaneous

PL c Cat. 3 SIL CL 2 2,00E-07 SIL 2 5,95E-03 20

All the units used within a safety function must be considered when calculating the safety characteristic data.

Supplementary data

The PFH value depends on the switching frequency and the load on the relay output. If the values in the service life table are not accessible, the stated PFH value can be used irrespective of the switching frequency and the load, as the PFH value already considers the relay's B10d value as well as the failure rates of the other components.

Service life table

The service life table indicates the number of cycles from which failures due to wear must be expected. The wear is mainly caused by the electrical load; the mechanical load is negligible.

| Load type | Switching current | Number of cycles |
|-----------|-------------------|------------------|
| DC1 | 3 A | 200,000 |
| DC13 | 1.5 A | 75,000 |
| AC1 | 3 A | 50,000 |
| AC15 | 1.5 A | 50,000 |

Order reference

| Product type | Features | Connection type | Order No. |
|--------------|----------|-------------------------|-----------|
| PNOZ s1 | 24 VDC | Screw terminals | 750 101 |
| PNOZ s1 C | 24 VDC | Spring-loaded terminals | 751 101 |

Safety relays PNOZsigma PNOZ s2

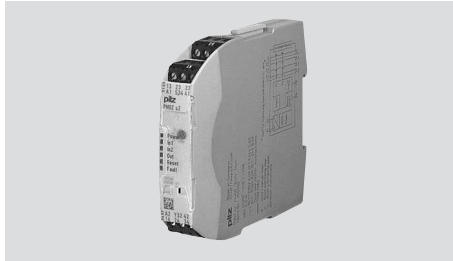

Unit features

- ▶ Positive-guided relay outputs:
 - 3 safety contacts (N/O), instantaneous
 - 1 auxiliary contact (N/C), instantaneous
- ▶ Protective separation of safety contacts from all other circuits
- ▶ 1 semiconductor output
- ▶ Connection options for:
 - E-STOP pushbutton
 - Safety gate limit switch
 - Start button
- ▶ A connector can be used to connect 1 PNOZsigma contact expansion module
- ▶ Operating modes can be set via rotary switch
- ▶ LED indicator for:
 - Supply voltage
 - Input status, channel 1
 - Input status, channel 2
 - Switch status of the safety contacts
 - Start circuit
 - Errors
- ▶ Plug-in connection terminals (either spring-loaded terminal or screw terminal)
- ▶ See order reference for unit types

Safety relays PNOZsigma PNOZ s2

Block diagram/terminal configuration

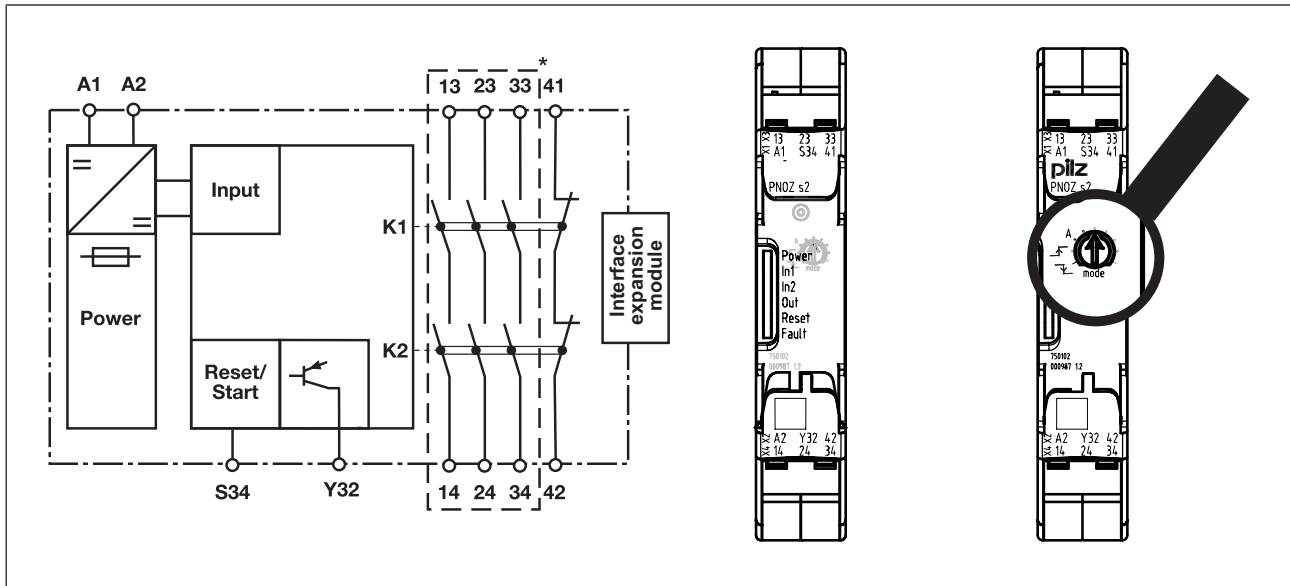



Fig.: Centre: Front view with cover, right: Front view without cover

*Safe separation from non-marked area in accordance with EN 60947-1, 6 kV, basic insulation between all safety contacts.

Function description

- ▶ Single-channel operation: No redundancy in the input circuit, earth faults in the start and input circuit are detected.
- ▶ **A** Automatic start: Unit is active once the input circuit has been closed.
- ▶ Manual start Unit is active once the input circuit and the start circuit are closed.
- ▶  Monitored start with falling edge: Unit is active once
 - the input circuit is closed and then the start circuit is closed and opened again.
 - the start circuit is closed and then opened again once the input circuit is closed.
- ▶  Monitored start with rising edge: Unit is active once the input circuit is closed and once the start circuit is closed after the waiting period has elapsed (see technical details).
- ▶ Increase in the number of available instantaneous safety contacts by connecting contact expander modules or external contactors/relays;
A connector can be used to connect 1 PNOZsigma contact expander module.

Safety relays PNOZsigma PNOZ s2

Timing diagram

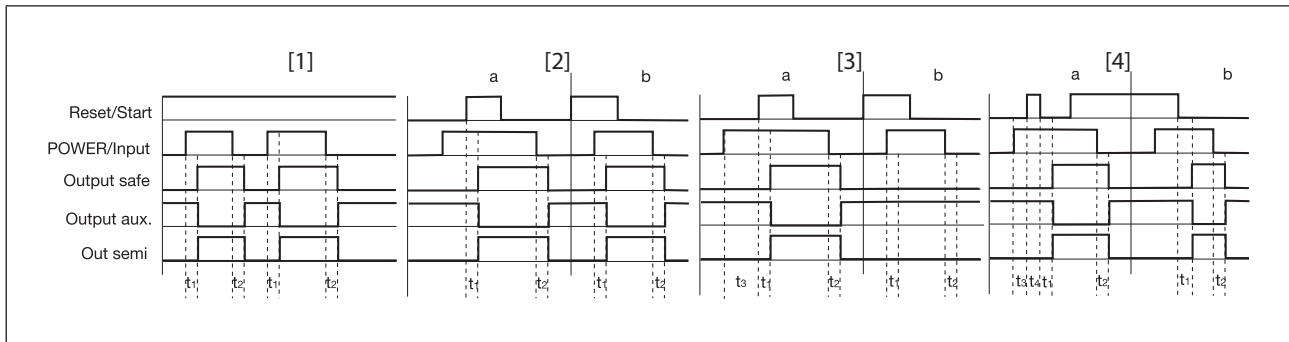

Legend

- ▶ Power: Supply voltage
- ▶ Start: Start circuit
- ▶ Input: Input circuits
- ▶ Output safe: Safety contacts
- ▶ Output aux.: Auxiliary contacts
- ▶ Out semi: Semiconductor output
- ▶ [1]: Automatic start
- ▶ [2]: Manual start
- ▶ [3]: Monitored start with rising edge
- ▶ [4]: Monitored start with falling edge
- ▶ a: Input circuit closes before start circuit
- ▶ b: Start circuit closes before input circuit
- ▶ t_1 : Switch-on delay
- ▶ t_2 : Delay-on de-energisation
- ▶ t_3 : Waiting period
- ▶ t_4 : Min. start pulse duration with a monitored start

Safety relays PNOZsigma PNOZ s2

Installation

Install base unit without contact expansion module:

- ▶ Ensure that the plug terminator is inserted at the side of the unit.

Connect base unit and PNOZsigma contact expansion module:

- ▶ Remove the plug terminator at the side of the base unit and at the contact expansion module.
- ▶ Connect the base unit and the contact expansion module to the supplied connector before mounting the units to the DIN rail.

Installation in control cabinet

- ▶ The safety relay should be installed in a control cabinet with a protection type of at least IP54.
- ▶ Use the notch on the rear of the unit to attach it to a DIN rail (35 mm).
- ▶ When installed vertically: Secure the unit by using a fixing element (e.g. retaining bracket or end angle).
- ▶ Push the device upwards or downwards before lifting it from the DIN rail.

Wiring

Please note:

- ▶ Information given in the "[Technical details \[565\]](#)" must be followed.
- ▶ Outputs 13-14, 23-24, 33-34 are safety contacts; output 41-42 is an auxiliary contact (e.g. for display).
- ▶ Auxiliary contact 41-42 and semiconductor output Y32 should **not** be used for safety circuits!
- ▶ To prevent contact welding, a fuse should be connected before the output contacts (see [Technical details \[565\]](#)).
- ▶ Calculation of the max. cable length l_{\max} in the input circuit:

$$l_{\max} = \frac{R_{l_{\max}}}{R_l / \text{km}}$$

$R_{l_{\max}}$ = max. overall cable resistance (see [Technical details \[565\]](#))

R_l / km = cable resistance/km

- ▶ Use copper wire that can withstand 60/75 °C.
- ▶ Sufficient fuse protection must be provided on all output contacts with capacitive and inductive loads.
- ▶ The power supply must comply with the regulations for extra low voltages with protective electrical separation (SELV, PELV) in accordance with VDE 0100, Part 410.
- ▶ Ensure the wiring and EMC requirements of IEC 60204-1 are met.

Safety relays PNOZsigma PNOZ s2



Preparing for operation

Operating modes

The operating mode is set via the rotary switch on the unit. You can do this by opening the cover on the front of the unit.

Set operating modes

- ▶ Switch off supply voltage.
- ▶ Select operating mode via the operating mode selector switch "mode".
- ▶ If the operating mode selector switch "mode" is in its start position (vertical position), an error message will appear.

| Operating mode selector switch "mode" | Automatic/manual start | Monitored start rising edge | Monitored start falling edge |
|---|--|---|--|
| without detection of shorts across contacts |  |  |  |

Connection

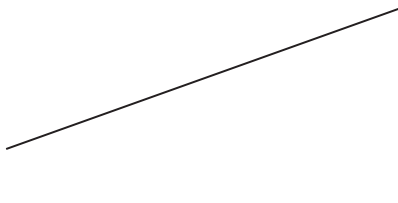
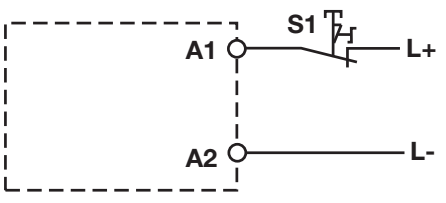
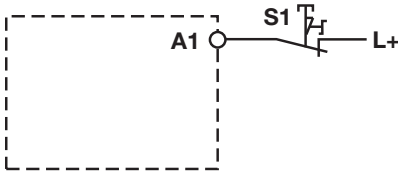
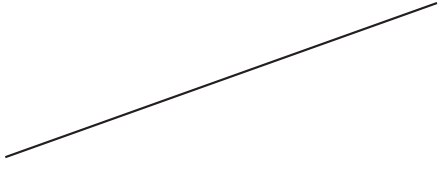
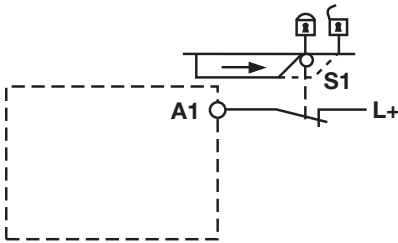
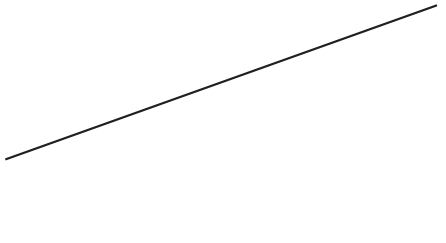
| Supply voltage | AC | DC |
|---|---|--|
| |  |  |
| Input circuit | Single-channel | Dual-channel |
| E-STOP without detection of shorts across contacts |  |  |
| Safety gate without detection of shorts across contacts |  |  |

Safety relays PNOZsigma PNOZ s2

| Start circuit/feedback loop | Without feedback loop monitoring | With feedback loop monitoring |
|-------------------------------------|----------------------------------|-------------------------------|
| Automatic start | | |
| Monitored, manual start/restart | | |
| Semiconductor output | | |
| <p style="text-align: right;">*</p> | | |

*Connect together the 0V connections on all the external power supplies

Dimensions in mm

*with spring-loaded terminals

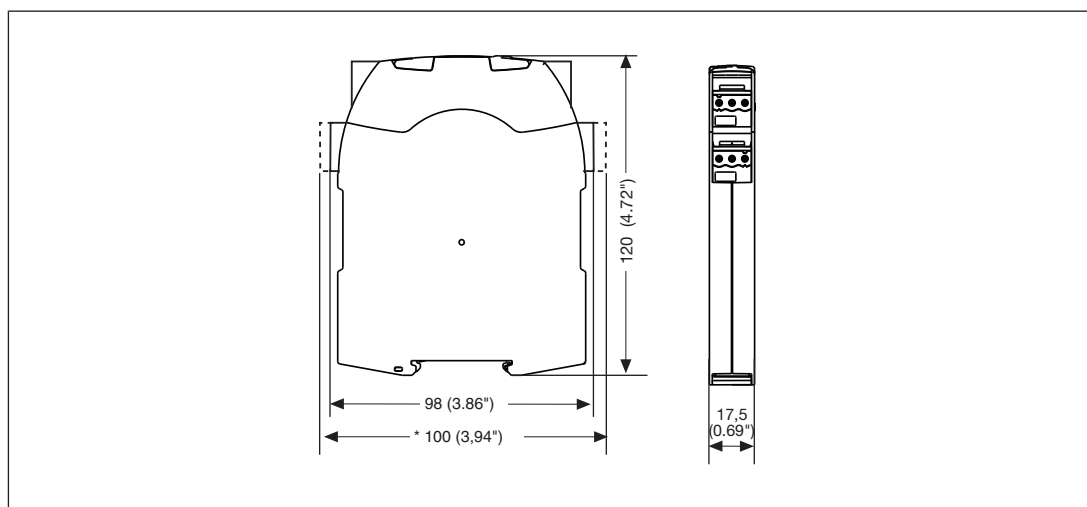

Safety relays PNOZsigma PNOZ s2

Technical Details

| General | 750102 | 751102 |
|--------------------------------------|--|--|
| Approvals | CCC, CE, EAC (Eurasian), KOSHA, TÜV, cULus Listed | CCC, CE, EAC (Eurasian), KOSHA, TÜV, cULus Listed |
| Electrical data | 750102 | 751102 |
| Supply voltage | | |
| Voltage | 24 V | 24 V |
| Kind | DC | DC |
| Voltage tolerance | -15 %/+10 % | -15 %/+10 % |
| Output of external power supply (DC) | 2 W | 2 W |
| Residual ripple DC | 20 % | 20 % |
| Duty cycle | 100 % | 100 % |
| Inputs | 750102 | 751102 |
| Number | 1 | 1 |
| Voltage at | | |
| Input circuit DC | 24 V | 24 V |
| Start circuit DC | 24 V | 24 V |
| Feedback loop DC | 24 V | 24 V |
| Current at | | |
| Input circuit DC | 75 mA | 75 mA |
| Start circuit DC | 7 mA | 7 mA |
| Feedback loop DC | 7 mA | 7 mA |
| Max. inrush current impulse | | |
| Current pulse, input circuit | 0,5 A | 0,5 A |
| Pulse duration, input circuit | 7 ms | 7 ms |
| Current pulse, feedback loop | 0,5 A | 0,5 A |
| Pulse duration, feedback loop | 30 ms | 30 ms |
| Current pulse, start circuit | 0,5 A | 0,5 A |
| Pulse duration, start circuit | 30 ms | 30 ms |
| Max. overall cable resistance RI-max | | |
| Single-channel at UB DC | 30 Ohm | 30 Ohm |
| Semiconductor outputs | 750102 | 751102 |
| Number | 1 | 1 |
| Voltage | 24 V | 24 V |
| Current | 20 mA | 20 mA |

Safety relays PNOZsigma PNOZ s2

| Relay outputs | 750102 | 751102 |
|--|--------------|--------------|
| Number of output contacts | | |
| Safety contacts (N/O), instantaneous | 3 | 3 |
| Auxiliary contacts (N/C) | 1 | 1 |
| Max. short circuit current IK | 1 kA | 1 kA |
| Utilisation category | | |
| In accordance with the standard | EN 60947-4-1 | EN 60947-4-1 |
| Utilisation category of safety contacts | | |
| AC1 at | 240 V | 240 V |
| Min. current | 0,01 A | 0,01 A |
| Max. current | 6 A | 6 A |
| Max. power | 1500 VA | 1500 VA |
| DC1 at | 24 V | 24 V |
| Min. current | 0,01 A | 0,01 A |
| Max. current | 6 A | 6 A |
| Max. power | 150 W | 150 W |
| Utilisation category of auxiliary contacts | | |
| AC1 at | 240 V | 240 V |
| Min. current | 0,01 A | 0,01 A |
| Max. current | 6 A | 6 A |
| Max. power | 1500 VA | 1500 VA |
| DC1 at | 24 V | 24 V |
| Min. current | 0,01 A | 0,01 A |
| Max. current | 6 A | 6 A |
| Max. power | 150 W | 150 W |
| Utilisation category | | |
| In accordance with the standard | EN 60947-5-1 | EN 60947-5-1 |
| Utilisation category of safety contacts | | |
| AC15 at | 230 V | 230 V |
| Max. current | 5 A | 5 A |
| DC13 (6 cycles/min) at | 24 V | 24 V |
| Max. current | 5 A | 5 A |
| Utilisation category of auxiliary contacts | | |
| AC15 at | 230 V | 230 V |
| Max. current | 5 A | 5 A |
| DC13 (6 cycles/min) at | 24 V | 24 V |
| Max. current | 5 A | 5 A |

Safety relays PNOZsigma PNOZ s2

| Relay outputs | 750102 | 751102 |
|--|-------------------------------|-------------------------------|
| Utilisation category in accordance with UL | | |
| Voltage | 240 V AC G.U. (same polarity) | 240 V AC G.U. (same polarity) |
| With current | 6 A | 6 A |
| Voltage | 24 V DC G. U. | 24 V DC G. U. |
| With current | 6 A | 6 A |
| External contact fuse protection, safety contacts | | |
| In accordance with the standard | EN 60947-5-1 | EN 60947-5-1 |
| Max. melting integral | 260 A ² s | 260 A ² s |
| Blow-out fuse, quick | 10 A | 10 A |
| Blow-out fuse, slow | 6 A | 6 A |
| Blow-out fuse, gG | 10 A | 10 A |
| Circuit breaker 24V AC/DC, characteristic B/C | 6 A | 6 A |
| External contact fuse protection, auxiliary contacts | | |
| Max. melting integral | 160 A ² s | 160 A ² s |
| Blow-out fuse, quick | 10 A | 10 A |
| Blow-out fuse, slow | 6 A | 6 A |
| Blow-out fuse, gG | 6 A | 6 A |
| Circuit breaker 24 V AC/DC, characteristic B/C | 6 A | 6 A |
| Contact material | AgCuNi + 0,2 µm Au | AgCuNi + 0,2 µm Au |
| Conventional thermal current while loading several contacts | 750102 | 751102 |
| I _{th} per contact at UB DC; AC1: 240 V, DC1: 24 V | | |
| Conv. therm. current with 1 contact | 6 A | 6 A |
| Conv. therm. current with 2 contacts | 6 A | 6 A |
| Conv. therm. current with 3 contacts | 5 A | 5 A |

Safety relays PNOZsigma PNOZ s2

| Times | 750102 | 751102 |
|--|---------------|---------------|
| Switch-on delay | | |
| With automatic start typ. | 75 ms | 75 ms |
| With automatic start max. | 250 ms | 250 ms |
| With automatic start after power on typ. | 75 ms | 75 ms |
| With automatic start after power on max. | 250 ms | 250 ms |
| With manual start typ. | 75 ms | 75 ms |
| With manual start max. | 250 ms | 250 ms |
| With monitored start with rising edge typ. | 75 ms | 75 ms |
| With monitored start with rising edge max. | 250 ms | 250 ms |
| With monitored start with falling edge typ. | 55 ms | 55 ms |
| With monitored start with falling edge max. | 70 ms | 70 ms |
| Delay-on de-energisation | | |
| With E-STOP typ. | 50 ms | 50 ms |
| With E-STOP max. | 70 ms | 70 ms |
| With power failure typ. | 50 ms | 50 ms |
| With power failure max. | 70 ms | 70 ms |
| Recovery time at max. switching frequency 1/s | | |
| After E-STOP | 100 ms | 100 ms |
| After power failure | 100 ms | 100 ms |
| Waiting period with a monitored start | | |
| With rising edge | 100 ms | 100 ms |
| With falling edge | 110 ms | 110 ms |
| Min. start pulse duration with a monitored start | | |
| With rising edge | 100 ms | 100 ms |
| With falling edge | 100 ms | 100 ms |
| Supply interruption before de-energisation | | |
| | 10 ms | 10 ms |
| Environmental data | 750102 | 751102 |
| Climatic suitability | EN 60068-2-78 | EN 60068-2-78 |
| Ambient temperature | | |
| Temperature range | -10 - 55 °C | -10 - 55 °C |
| Storage temperature | | |
| Temperature range | -40 - 85 °C | -40 - 85 °C |

Safety relays PNOZsigma PNOZ s2

| Environmental data | 750102 | 751102 |
|---|--|--|
| Climatic suitability | | |
| Humidity | 93 % r. h. at 40 °C | 93 % r. h. at 40 °C |
| Condensation during operation | Not permitted | Not permitted |
| EMC | EN 60947-5-1, EN 61000-6-2, EN 61000-6-4, EN 61326-3-1 | EN 60947-5-1, EN 61000-6-2, EN 61000-6-4, EN 61326-3-1 |
| Vibration | | |
| In accordance with the standard | EN 60068-2-6 | EN 60068-2-6 |
| Frequency | 10 - 55 Hz | 10 - 55 Hz |
| Amplitude | 0,35 mm | 0,35 mm |
| Airgap creepage | | |
| In accordance with the standard | EN 60947-1 | EN 60947-1 |
| Overvoltage category | III | III |
| Pollution degree | 2 | 2 |
| Rated insulation voltage | 250 V | 250 V |
| Rated impulse withstand voltage | 6 kV | 6 kV |
| Protection type | | |
| Mounting area (e.g. control cabinet) | IP54 | IP54 |
| Housing | IP40 | IP40 |
| Terminals | IP20 | IP20 |
| Mechanical data | 750102 | 751102 |
| Mounting position | Any | Any |
| Mechanical life | 10,000,000 cycles | 10,000,000 cycles |
| Material | | |
| Bottom | PC | PC |
| Front | PC | PC |
| Top | PC | PC |
| Connection type | Screw terminal | Spring-loaded terminal |
| Mounting type | plug-in | plug-in |
| Conductor cross section with screw terminals | | |
| 1 core flexible | 0,25 - 2,5 mm ² , 24 - 12 AWG | – |
| 2 core with the same cross section, flexible with crimp connectors, no plastic sleeve | 0,25 - 1 mm ² , 24 - 16 AWG | – |
| 2 core with the same cross section, flexible without crimp connectors or with TWIN crimp connectors | 0,2 - 1,5 mm ² , 24 - 16 AWG | – |
| Torque setting with screw terminals | 0,5 Nm | – |
| Conductor cross section with spring-loaded terminals: Flexible with/without crimp connector | – | 0,2 - 2,5 mm ² , 24 - 12 AWG |

Safety relays PNOZsigma PNOZ s2

| Mechanical data | 750102 | 751102 |
|---|---------|---------|
| Spring-loaded terminals: Terminal points per connection | – | 2 |
| Stripping length with spring-loaded terminals | – | 9 mm |
| Dimensions | | |
| Height | 98 mm | 100 mm |
| Width | 17,5 mm | 17,5 mm |
| Depth | 120 mm | 120 mm |
| Weight | 175 g | 175 g |

Where standards are undated, the 2014-07 latest editions shall apply.

Safety characteristic data

| Operating Mode | EN ISO 13849-1: 2015 PL | EN ISO 13849-1: 2015 Category | EN 62061 SIL CL | EN 62061 PFH _D [1/h] | IEC 61511 SIL | IEC 61511 PFD | EN ISO 13849-1: 2015 T _M [year] |
|--------------------------------|----------------------------|----------------------------------|--------------------|------------------------------------|------------------|------------------|---|
| Safety contacts, instantaneous | PL e | Cat. 4 | SIL CL 3 | 2,50E-09 | SIL 3 | 2,13E-05 | 20 |

All the units used within a safety function must be considered when calculating the safety characteristic data.

Supplementary data

The PFH value depends on the switching frequency and the load on the relay output. If the service life graphs are not accessible, the stated PFH value can be used irrespective of the switching frequency and the load, as the PFH value already considers the relay's B10d value as well as the failure rates of the other components.

Safety relays PNOZsigma PNOZ s2

Service life graph

The service life graphs indicate the number of cycles from which failures due to wear must be expected. The wear is mainly caused by the electrical load; the mechanical load is negligible.

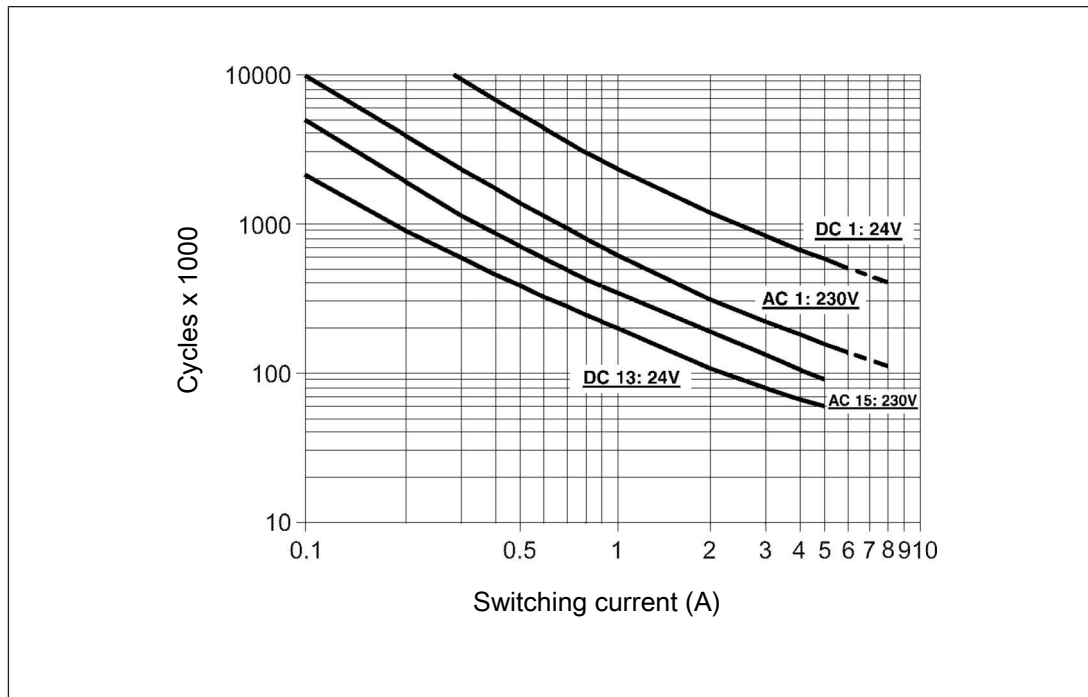

Fig.: Service life graphs at 24 V DC and 230 V AC

Safety relays PNOZsigma PNOZ s2

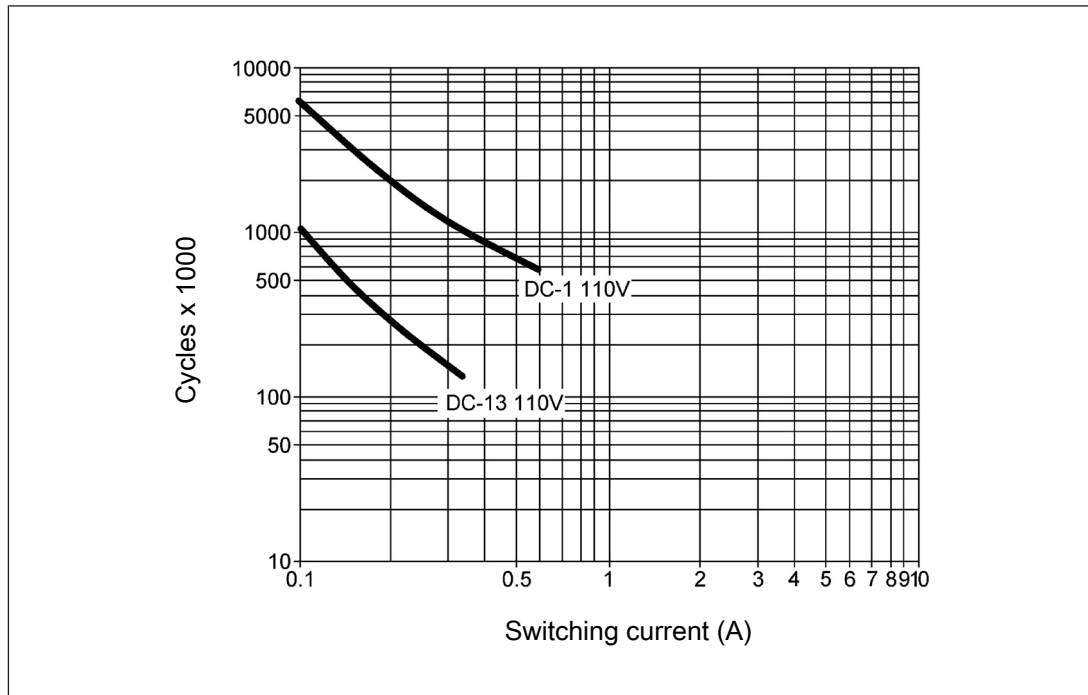

Fig.: Service life graphs at 110 V DC

Example

- ▶ Inductive load: 0.2 A
- ▶ Utilisation category: AC15
- ▶ Contact service life: 2 000 000 cycles

Provided the application to be implemented requires fewer than 2 000 000 cycles, the PFH value (see [Technical details \[565\]](#)) can be used in the calculation.

To increase the service life, sufficient spark suppression must be provided on all output contacts. With capacitive loads, any power surges that occur must be noted. With DC contactors, use flywheel diodes for spark suppression.

Order reference

| Product type | Features | Connection type | Order No. |
|--------------|----------|-------------------------|-----------|
| PNOZ s2 | 24 V DC | Screw terminals | 750 102 |
| PNOZ s2 C | 24 V DC | Spring-loaded terminals | 751 102 |

Safety relays PNOZsigma PNOZ s3



Unit features

- ▶ Positive-guided relay outputs:
 - 2 safety contacts (N/O), instantaneous
- ▶ 1 semiconductor output
- ▶ Connection options for:
 - E-STOP pushbuttons
 - Safety gate limit switches
 - Start buttons
 - Light grids and safety switches with detection of shorts across contacts
- ▶ A connector can be used to connect 1 PNOZsigma contact expansion module
- ▶ Operating modes can be set via rotary switch
- ▶ LED indicator for:
 - Supply voltage
 - Input status, channel 1
 - Input status, channel 2
 - Switch status channel 1/2
 - Start circuit
 - Error
- ▶ Plug-in connection terminals (either spring-loaded terminal or screw terminal)
- ▶ See order reference for unit types

Safety relays PNOZsigma PNOZ s3

Block diagram/terminal configuration

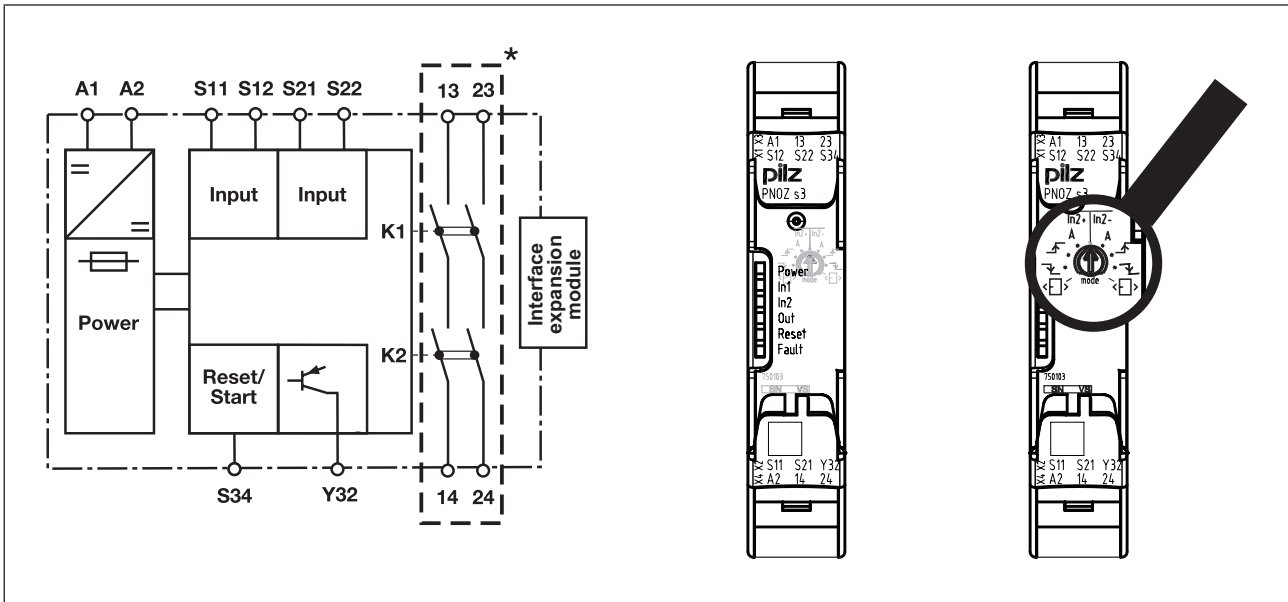



Fig.: Centre: Front view with cover, right: Front view without cover

*Insulation between the non-marked area and the relay contacts: Basic insulation (over-voltage category III), Protective separation (overvoltage category II)

Function description

- ▶ $\overline{\text{In}2+}$ Single-channel operation: no redundancy in the input circuit, earth faults in the start circuit and input circuit are detected.
- ▶ Dual-channel operation without detection of shorts across contacts: Redundant input circuit, detects PNOZ s3
 - earth faults in the start and input circuit,
 - short circuits in the input circuit and, with a monitored start, in the start circuit too.
- ▶ $\overline{\text{In}2-}$ Dual-channel operation with detection of shorts across contacts: Redundant input circuit, detects PNOZ s3
 - earth faults in the start and input circuit,
 - Short circuits in the input circuit and, with a monitored start, in the start circuit too,
 - Shorts across contacts in the input circuit.
- ▶ **A** Automatic start: Unit is active once the input circuit has been closed.
- ▶ Manual start Unit is active once the input circuit and the start circuit are closed.
- ▶ $\overline{\text{In}2-}$ Monitored start with falling edge: Unit is active once
 - the input circuit is closed and then the start circuit is closed and opened again.
 - the start circuit is closed and then opened again once the input circuit is closed.

Safety relays PNOZsigma PNOZ s3

- ▶  Monitored start with rising edge: Unit is active once the input circuit is closed and once the start circuit is closed after the waiting period has elapsed (see technical details).
- ▶  Start with start-up test: The unit checks whether safety gates that are closed are opened and then closed again when supply voltage is applied.
- ▶ Increase in the number of available instantaneous safety contacts by connecting contact expander modules or external contactors/relays;
A connector can be used to connect 1 PNOZsigma contact expander module.

Timing diagram

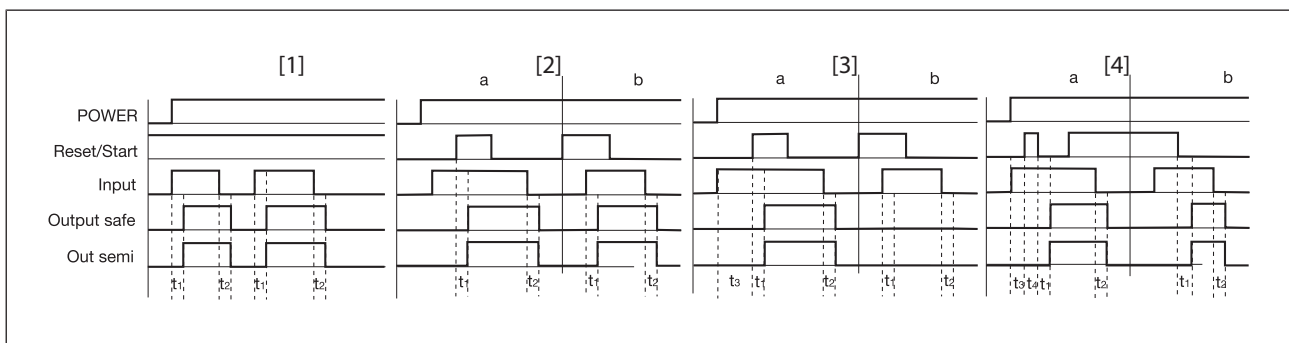

Legend

- ▶ POWER: Supply voltage
- ▶ Start: Start circuit
- ▶ Input: Input circuits
- ▶ Output safe: Safety contacts
- ▶ Out semi: Semiconductor output
- ▶ [1]: Automatic start
- ▶ [2]: Manual start
- ▶ [3]: Monitored start with rising edge
- ▶ [4]: Monitored start with falling edge
- ▶ a: Input circuit closes before start circuit
- ▶ b: Start circuit closes before input circuit
- ▶ t_1 : Switch-on delay
- ▶ t_2 : Delay-on de-energisation
- ▶ t_3 : Waiting period with a monitored start
- ▶ t_4 : Min. start pulse duration with a monitored start

Safety relays PNOZsigma PNOZ s3

Installation

Install base unit without contact expansion module:

- ▶ Ensure that the plug terminator is inserted at the side of the unit.

Connect base unit and PNOZsigma contact expansion module:

- ▶ Remove the plug terminator at the side of the base unit and at the contact expansion module.
- ▶ Connect the base unit and the contact expansion module to the supplied connector before mounting the units to the DIN rail.

Installation in control cabinet

- ▶ The safety relay should be installed in a control cabinet with a protection type of at least IP54.
- ▶ Use the notch on the rear of the unit to attach it to a DIN rail (35 mm).
- ▶ When installed vertically: Secure the unit by using a fixing element (e.g. retaining bracket or end angle).
- ▶ Push the device upwards or downwards before lifting it from the DIN rail.

Wiring

Please note:

- ▶ Information given in the "[Technical details \[580\]](#)" must be followed.
- ▶ Outputs 13-14 and 23-24 are safety contacts, the semiconductor output Y32 is an auxiliary output (e.g. for display).
- ▶ Semiconductor output Y32 should **not** be used for safety circuits!
- ▶ To prevent contact welding, a fuse should be connected before the output contacts (see [Technical details \[580\]](#)).
- ▶ Calculation of the max. cable length l_{\max} in the input circuit:

$$l_{\max} = \frac{R_{l_{\max}}}{R_l / \text{km}}$$

$R_{l_{\max}}$ = max. overall cable resistance (see [Technical details \[580\]](#))

R_l / km = cable resistance/km

- ▶ Use copper wire that can withstand 60/75 °C.
- ▶ Sufficient fuse protection must be provided on all output contacts with capacitive and inductive loads.
- ▶ When connecting magnetically operated, reed proximity switches, ensure that the max. peak inrush current (on the input circuit) does not overload the proximity switch.
- ▶ Ensure the wiring and EMC requirements of IEC 60204-1 are met.
- ▶ The power supply must comply with the regulations for extra low voltages with protective electrical separation (SELV, PELV) in accordance with VDE 0100, Part 410.

Safety relays PNOZsigma PNOZ s3









Preparing for operation

Operating modes

The operating mode is set via the rotary switch on the unit. You can do this by opening the cover on the front of the unit.

Set operating modes

- ▶ Switch off supply voltage.
- ▶ Select operating mode via the operating mode selector switch "mode".
- ▶ If the operating mode selector switch "mode" is in its start position (vertical position), an error message will appear.

| Operating mode selector switch "mode" | Automatic or manual start | Monitored start rising edge | Monitored start falling edge | Automatic start with start-up test |
|---|---|---|---|---|
| Without detection of shorts across contacts |  |  |  |  |
| With detection of shorts across contacts |  |  |  |  |

Safety relays PNOZsigma PNOZ s3

Connection

| Supply voltage | AC | DC |
|---|----------------|--------------|
| | | |
| Input circuit | Single-channel | Dual-channel |
| E-STOP without detection of shorts across contacts | | |
| E-STOP with detection of shorts across contacts | | |
| Safety gate without detection of shorts across contacts | | |
| Safety gate with detection of shorts across contacts | | |

Safety relays PNOZsigma PNOZ s3

| Input circuit | Single-channel | Dual-channel |
|---|----------------------------------|-------------------------------|
| Light beam device or safety switch, detection of shorts across contacts via ESPE | | |
| Start circuit/feedback loop | Without feedback loop monitoring | with feedback loop monitoring |
| Automatic start | | |
| Monitored, manual start/restart | | |
| Semiconductor output | | |
| <p style="text-align: center;">* Y32 — PLC Input</p> <p>*Connect together the 0V connections on all the external power supplies</p> | | |

Safety relays PNOZsigma PNOZ s3

Dimensions in mm

*with spring-loaded terminals

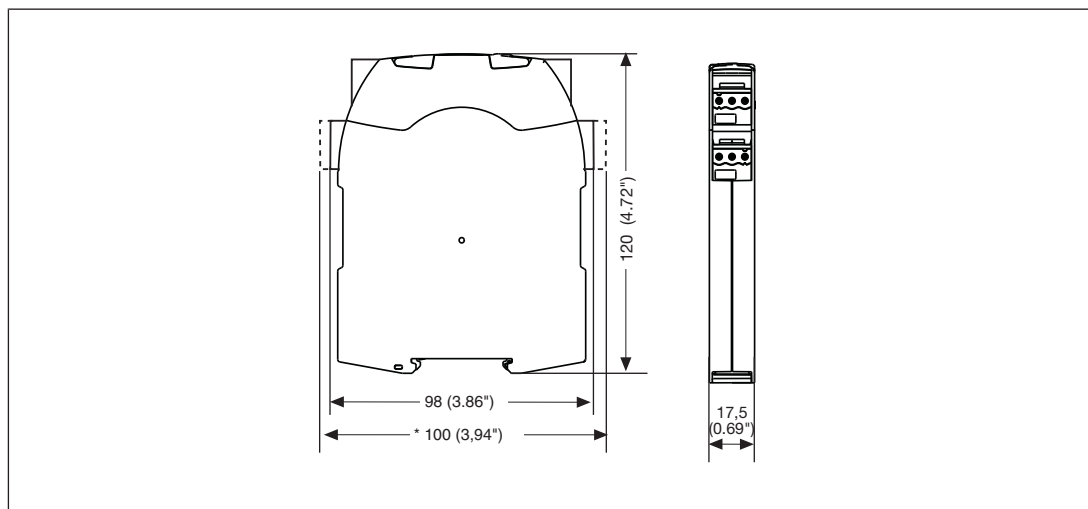

Technical Details

| General | 750103 | 751103 |
|--------------------------------------|--|--|
| Approvals | CCC, CE, EAC (Eurasian), KOSHA, TÜV, cULus Listed | CCC, CE, EAC (Eurasian), KOSHA, TÜV, cULus Listed |
| Electrical data | 750103 | 751103 |
| Supply voltage | | |
| Voltage | 24 V | 24 V |
| Kind | DC | DC |
| Voltage tolerance | -15 %/+10 % | -15 %/+10 % |
| Output of external power supply (DC) | 2,5 W | 2,5 W |
| Residual ripple DC | 20 % | 20 % |
| Duty cycle | 100 % | 100 % |
| Max. inrush current impulse | | |
| Current pulse, A1 | 0,5 A | 0,5 A |
| Pulse duration, A1 | 5 ms | 5 ms |
| Inputs | 750103 | 751103 |
| Number | 2 | 2 |
| Voltage at | | |
| Input circuit DC | 24 V | 24 V |
| Start circuit DC | 24 V | 24 V |
| Feedback loop DC | 24 V | 24 V |

Safety relays PNOZsigma PNOZ s3

| Inputs | 750103 | 751103 |
|---|---------------|---------------|
| Current at | | |
| Input circuit DC | 50 mA | 50 mA |
| Start circuit DC | 50 mA | 50 mA |
| Feedback loop DC | 50 mA | 50 mA |
| Max. inrush current impulse | | |
| Current pulse, input circuit | 0,2 A | 0,2 A |
| Pulse duration, input circuit | 100 ms | 100 ms |
| Current pulse, feedback loop | 0,2 A | 0,2 A |
| Pulse duration, feedback loop | 15 ms | 15 ms |
| Current pulse, start circuit | 0,2 A | 0,2 A |
| Pulse duration, start circuit | 15 ms | 15 ms |
| Min. input resistance at power-on | 110 Ohm | 110 Ohm |
| Max. overall cable resistance RI-max | | |
| Single-channel at UB DC | 30 Ohm | 30 Ohm |
| Dual-channel without detection of shorts across contacts at UB DC | 60 Ohm | 60 Ohm |
| Dual-channel with detection of shorts across contacts at UB DC | 30 Ohm | 30 Ohm |
| Semiconductor outputs | 750103 | 751103 |
| Number | 1 | 1 |
| Voltage | 24 V | 24 V |
| Current | 20 mA | 20 mA |
| Relay outputs | 750103 | 751103 |
| Number of output contacts | | |
| Safety contacts (N/O), instantaneous | 2 | 2 |
| Max. short circuit current IK | 1 kA | 1 kA |
| Utilisation category | | |
| In accordance with the standard | EN 60947-4-1 | EN 60947-4-1 |
| Utilisation category of safety contacts | | |
| AC1 at | 240 V | 240 V |
| Min. current | 0,01 A | 0,01 A |
| Max. current | 6 A | 6 A |
| Max. power | 1500 VA | 1500 VA |
| DC1 at | 24 V | 24 V |
| Min. current | 0,01 A | 0,01 A |
| Max. current | 6 A | 6 A |
| Max. power | 150 W | 150 W |

Safety relays PNOZsigma PNOZ s3

| Relay outputs | 750103 | 751103 |
|---|--------------------------------------|--------------------------------------|
| Utilisation category | | |
| In accordance with the standard | EN 60947-5-1 | EN 60947-5-1 |
| Utilisation category of safety contacts | | |
| AC15 at | 230 V | 230 V |
| Max. current | 5 A | 5 A |
| DC13 (6 cycles/min) at | 24 V | 24 V |
| Max. current | 5 A | 5 A |
| Utilisation category in accordance with UL | | |
| Voltage | 240 V AC G.U. (same polarity) | 240 V AC G.U. (same polarity) |
| With current | 6 A | 6 A |
| Voltage | 24 V DC G. U. | 24 V DC G. U. |
| With current | 6 A | 6 A |
| External contact fuse protection, safety contacts | | |
| In accordance with the standard | EN 60947-5-1 | EN 60947-5-1 |
| Max. melting integral | 260 A²s | 260 A²s |
| Blow-out fuse, quick | 10 A | 10 A |
| Blow-out fuse, slow | 6 A | 6 A |
| Blow-out fuse, gG | 10 A | 10 A |
| Circuit breaker 24V AC/DC, characteristic B/C | 6 A | 6 A |
| Conventional thermal current | 6 A | 6 A |
| Contact material | AgCuNi + 0,2 µm Au | AgCuNi + 0,2 µm Au |
| Times | 750103 | 751103 |
| Switch-on delay | | |
| With automatic start typ. | 170 ms | 170 ms |
| With automatic start max. | 300 ms | 300 ms |
| With automatic start after power on typ. | 350 ms | 350 ms |
| With automatic start after power on max. | 600 ms | 600 ms |
| With manual start typ. | 40 ms | 40 ms |
| With monitored start with rising edge typ. | 35 ms | 35 ms |
| With monitored start with rising edge max. | 50 ms | 50 ms |
| With monitored start with falling edge typ. | 55 ms | 55 ms |
| With monitored start with falling edge max. | 70 ms | 70 ms |

Safety relays PNOZsigma PNOZ s3

| Times | 750103 | 751103 |
|--|--|--|
| Delay-on de-energisation | | |
| With E-STOP typ. | 10 ms | 10 ms |
| With E-STOP max. | 20 ms | 20 ms |
| With power failure typ. | 40 ms | 40 ms |
| With power failure max. | 60 ms | 60 ms |
| Recovery time at max. switching frequency 1/s | | |
| After E-STOP | 100 ms | 100 ms |
| After power failure | 100 ms | 100 ms |
| Waiting period with a monitored start | | |
| With rising edge | 120 ms | 120 ms |
| With falling edge | 250 ms | 250 ms |
| Min. start pulse duration with a monitored start | | |
| With rising edge | 30 ms | 30 ms |
| With falling edge | 100 ms | 100 ms |
| Supply interruption before de-energisation | 20 ms | 20 ms |
| Simultaneity, channel 1 and 2 max. | ∞ | ∞ |
| Environmental data | 750103 | 751103 |
| Climatic suitability | EN 60068-2-78 | EN 60068-2-78 |
| Ambient temperature | | |
| Temperature range | -10 - 55 °C | -10 - 55 °C |
| Storage temperature | | |
| Temperature range | -40 - 85 °C | -40 - 85 °C |
| Climatic suitability | | |
| Humidity | 93 % r. h. at 40 °C | 93 % r. h. at 40 °C |
| Condensation during operation | Not permitted | Not permitted |
| EMC | EN 60947-5-1, EN 61000-6-2, EN 61000-6-4, EN 61326-3-1 | EN 60947-5-1, EN 61000-6-2, EN 61000-6-4, EN 61326-3-1 |
| Vibration | | |
| In accordance with the standard | EN 60068-2-6 | EN 60068-2-6 |
| Frequency | 10 - 55 Hz | 10 - 55 Hz |
| Amplitude | 0,35 mm | 0,35 mm |
| Airgap creepage | | |
| In accordance with the standard | EN 60947-1 | EN 60947-1 |
| Overvoltage category | III / II | III / II |
| Pollution degree | 2 | 2 |
| Rated insulation voltage | 250 V | 250 V |
| Rated impulse withstand voltage | 4 kV | 4 kV |

Safety relays PNOZsigma PNOZ s3

| Environmental data | 750103 | 751103 |
|---|---|--|
| Protection type | | |
| Mounting area (e.g. control cabinet) | IP54 | IP54 |
| Housing | IP40 | IP40 |
| Terminals | IP20 | IP20 |
| Mechanical data | 750103 | 751103 |
| Mounting position | Any | Any |
| Mechanical life | 10,000,000 cycles | 10,000,000 cycles |
| Material | | |
| Bottom | PC | PC |
| Front | PC | PC |
| Top | PC | PC |
| Connection type | Screw terminal | Spring-loaded terminal |
| Mounting type | plug-in | plug-in |
| Conductor cross section with screw terminals | | |
| 1 core flexible | 0,25 - 2,5 mm², 24 - 12 AWG | – |
| 2 core with the same cross section, flexible with crimp connectors, no plastic sleeve | 0,25 - 1 mm², 24 - 16 AWG | – |
| 2 core with the same cross section, flexible without crimp connectors or with TWIN crimp connectors | 0,2 - 1,5 mm², 24 - 16 AWG | – |
| Torque setting with screw terminals | 0,5 Nm | – |
| Conductor cross section with spring-loaded terminals: Flexible with/without crimp connector | – | 0,2 - 2,5 mm², 24 - 12 AWG |
| Spring-loaded terminals: Terminal points per connection | – | 2 |
| Stripping length with spring-loaded terminals | – | 9 mm |
| Dimensions | | |
| Height | 98 mm | 100 mm |
| Width | 17,5 mm | 17,5 mm |
| Depth | 120 mm | 120 mm |
| Weight | 140 g | 140 g |

Where standards are undated, the 2014-07 latest editions shall apply.

Safety relays PNOZsigma PNOZ s3

Safety characteristic data

| Operating Mode | EN ISO 13849-1: 2015 PL | EN ISO 13849-1: 2015 Category | EN 62061 SIL CL | EN 62061 PFH _D [1/h] | IEC 61511 SIL | IEC 61511 PFD | EN ISO 13849-1: 2015 T _M [year] |
|--------------------------------|----------------------------|----------------------------------|--------------------|------------------------------------|------------------|------------------|---|
| Safety contacts, instantaneous | PL e | Cat. 4 | SIL CL 3 | 2,31E-09 | SIL 3 | 2,03E-06 | 20 |

All the units used within a safety function must be considered when calculating the safety characteristic data.

Supplementary data

The PFH value depends on the switching frequency and the load on the relay output. If the service life graphs are not accessible, the stated PFH value can be used irrespective of the switching frequency and the load, as the PFH value already considers the relay's B10d value as well as the failure rates of the other components.

Safety relays PNOZsigma PNOZ s3

Service life graph

The service life graphs indicate the number of cycles from which failures due to wear must be expected. The wear is mainly caused by the electrical load; the mechanical load is negligible.

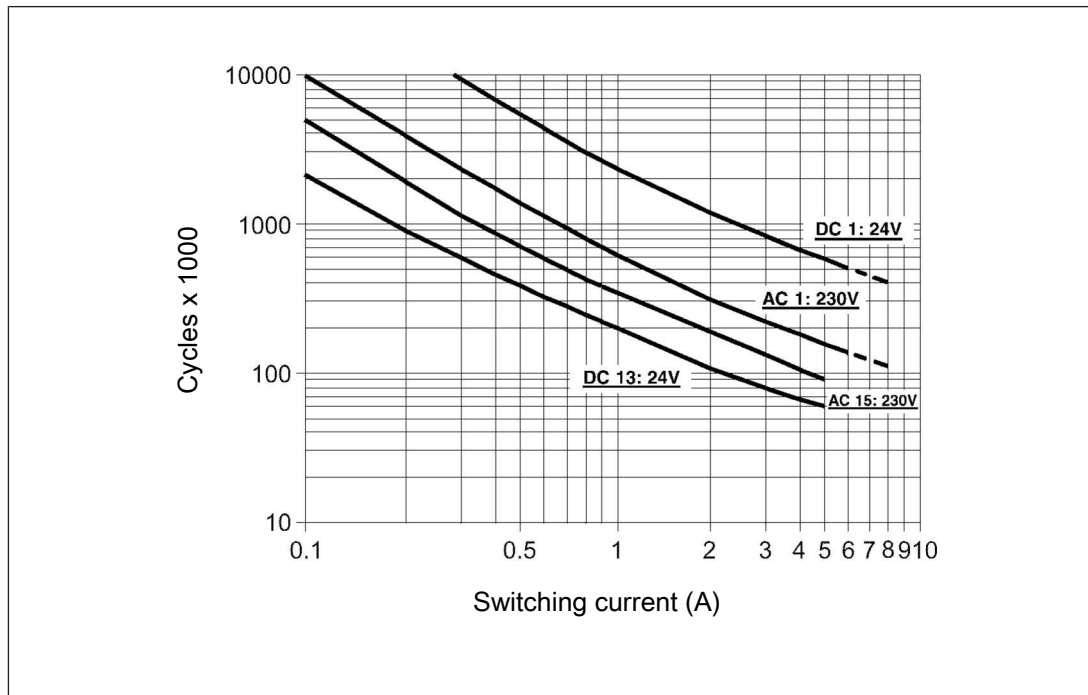

Fig.: Service life graphs at 24 V DC and 230 V AC

Safety relays PNOZsigma PNOZ s3

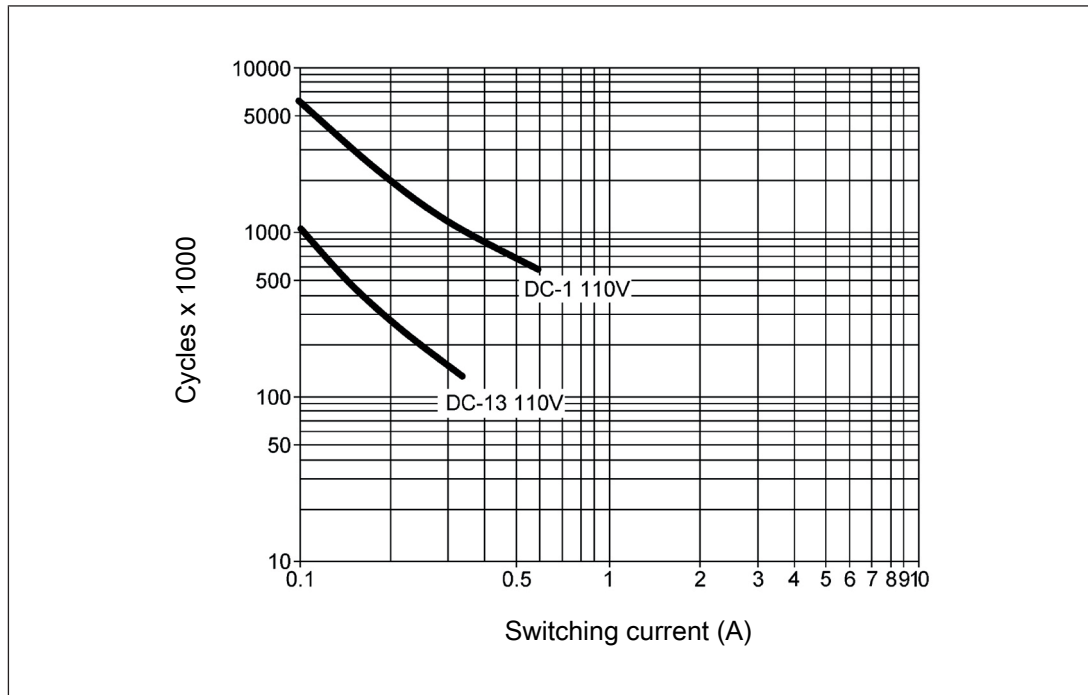

Fig.: Service life graphs at 110 V DC

Example

- ▶ Inductive load: 0.2 A
- ▶ Utilisation category: AC15
- ▶ Contact service life: 2 000 000 cycles

Provided the application to be implemented requires fewer than 2 000 000 cycles, the PFH value (see [Technical details \[580\]](#)) can be used in the calculation.

To increase the service life, sufficient spark suppression must be provided on all output contacts. With capacitive loads, any power surges that occur must be noted. With DC contactors, use flywheel diodes for spark suppression.

Order reference

| Product type | Features | Connection type | Order No. |
|--------------|----------|-------------------------|-----------|
| PNOZ s3 | 24 VDC | Screw terminals | 750 103 |
| PNOZ s3 C | 24 VDC | Spring-loaded terminals | 751 103 |

Safety relays PNOZsigma PNOZ s4



Unit features

- ▶ Positive-guided relay outputs:
 - 3 safety contacts (N/O), instantaneous
 - 1 auxiliary contact (N/C), instantaneous
- ▶ 1 semiconductor output
- ▶ Connection options for:
 - E-STOP pushbuttons
 - Safety gate limit switches
 - Start buttons
 - Light grids and safety switches with detection of shorts across contacts
- ▶ A connector can be used to connect 1 PNOZsigma contact expansion module
- ▶ Operating modes can be set via rotary switch
- ▶ LED indicator for:
 - Supply voltage
 - Input status, channel 1
 - Input status, channel 2
 - Switch status of the safety contacts
 - Start circuit
 - Errors
- ▶ Plug-in connection terminals (either spring-loaded terminal or screw terminal)
- ▶ See order reference for unit types

Safety relays PNOZsigma PNOZ s4

Block diagram/terminal configuration

Unit types with UB 24 VDC

- ▶ U_B : 24 VDC; Order no. 750104, 751104, 751184

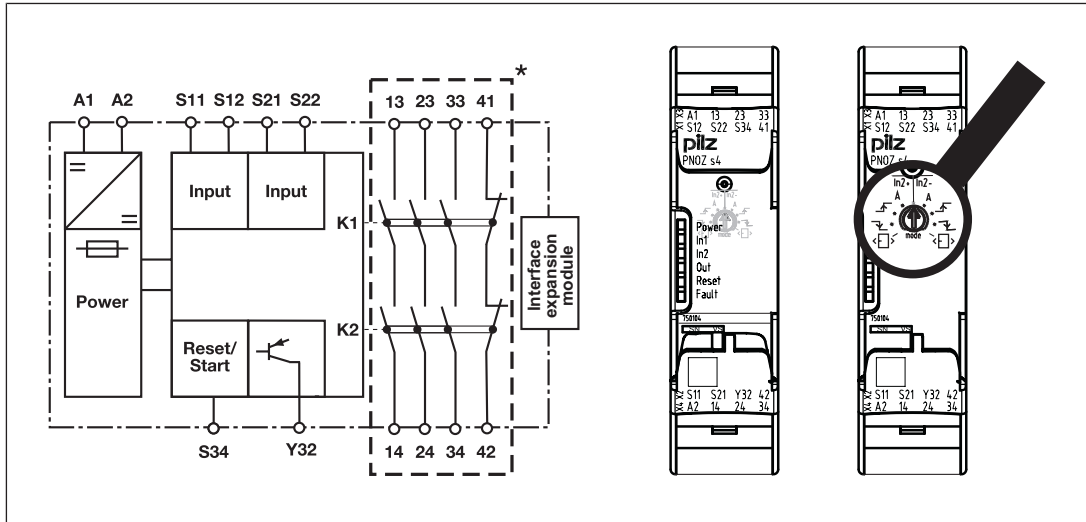

Fig.: Centre: Front view with cover, right: Front view without cover

*Insulation between the non-marked area and the relay contacts: Basic insulation (over-voltage category III), Protective separation (overvoltage category II)

Unit types with UB 48 - 240 VAC/DC

- ▶ U_B : 48 - 240 VAC/DC; Order no. 750134, 751134

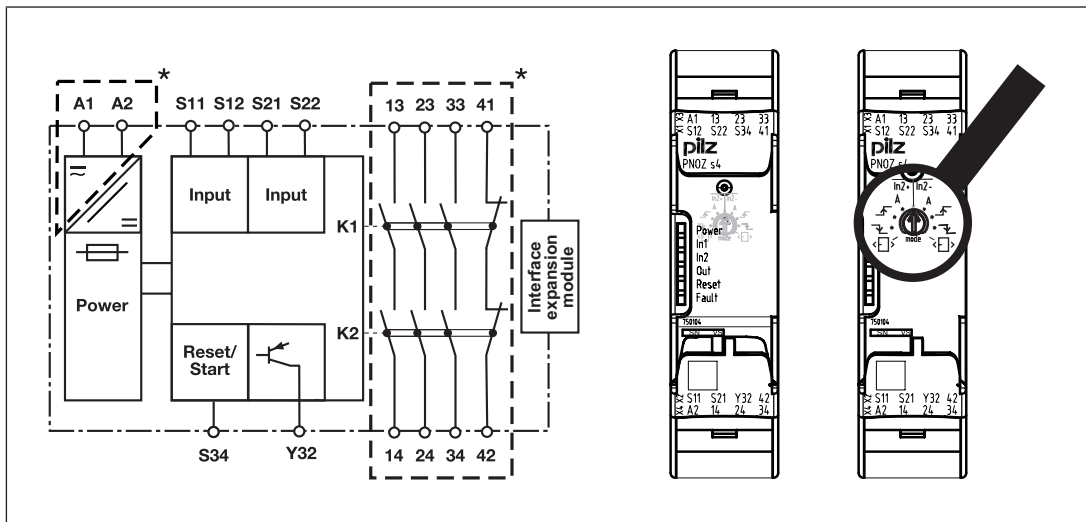

Fig.: Centre: Front view with cover, right: Front view without cover

*Insulation between the non-marked area and the relay contacts: Basic insulation (over-voltage category III), Protective separation (overvoltage category II)

Safety relays PNOZsigma PNOZ s4

Function description

- ▶ $\overline{\text{In}2\text{+}}$ Single-channel operation: no redundancy in the input circuit, earth faults in the start circuit and input circuit are detected.
- ▶ Dual-channel operation without detection of shorts across contacts: Redundant input circuit, detects PNOZ s4
 - earth faults in the start and input circuit,
 - short circuits in the input circuit and, with a monitored start, in the start circuit too.
- ▶ $\overline{\text{In}2\text{-}}$ Dual-channel operation with detection of shorts across contacts: Redundant input circuit, detects PNOZ s4
 - earth faults in the start and input circuit,
 - Short circuits in the input circuit and, with a monitored start, in the start circuit too,
 - Shorts across contacts in the input circuit.
- ▶ **A** Automatic start: Unit is active once the input circuit has been closed.
- ▶ Manual start Unit is active once the input circuit and the start circuit are closed.
- ▶ $\overline{\downarrow}$ Monitored start with falling edge: Unit is active once
 - the input circuit is closed and then the start circuit is closed and opened again.
 - the start circuit is closed and then opened again once the input circuit is closed.
- ▶ \uparrow Monitored start with rising edge: Unit is active once the input circuit is closed and once the start circuit is closed after the waiting period has elapsed (see technical details).
- ▶ \square Start with start-up test: The unit checks whether safety gates that are closed are opened and then closed again when supply voltage is applied.
- ▶ Increase in the number of available instantaneous safety contacts by connecting contact expander modules or external contactors/relays;
A connector can be used to connect 1 PNOZsigma contact expander module.

Safety relays PNOZsigma PNOZ s4

Timing diagram

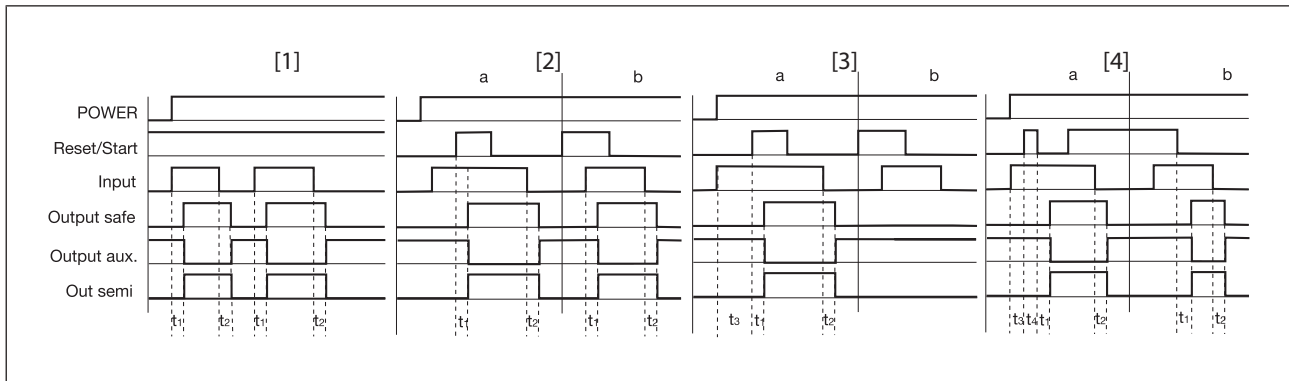

Legend

- ▶ POWER: Supply voltage
- ▶ Start: Start circuit
- ▶ Input: Input circuits
- ▶ Output safe: Safety contacts
- ▶ Output aux.: Auxiliary contacts
- ▶ Out semi: Semiconductor output
- ▶ [1]: Automatic start
- ▶ [2]: Manual start
- ▶ [3]: Monitored start with rising edge
- ▶ [4]: Monitored start with falling edge
- ▶ a: Input circuit closes before start circuit
- ▶ b: Start circuit closes before input circuit
- ▶ t_1 : Switch-on delay
- ▶ t_2 : Delay-on de-energisation
- ▶ t_3 : Waiting period with a monitored start
- ▶ t_4 : Min. start pulse duration with a monitored start

Safety relays PNOZsigma PNOZ s4

Installation

Install base unit without contact expansion module:

- ▶ Ensure that the plug terminator is inserted at the side of the unit.

Connect base unit and PNOZsigma contact expansion module:

- ▶ Remove the plug terminator at the side of the base unit and at the contact expansion module.
- ▶ Connect the base unit and the contact expansion module to the supplied connector before mounting the units to the DIN rail.

Installation in control cabinet

- ▶ The safety relay should be installed in a control cabinet with a protection type of at least IP54.
- ▶ Use the notch on the rear of the unit to attach it to a DIN rail (35 mm).
- ▶ When installed vertically: Secure the unit by using a fixing element (e.g. retaining bracket or end angle).
- ▶ Push the device upwards or downwards before lifting it from the DIN rail.

Wiring

Please note:

- ▶ Information given in the "[Technical details \[596\]](#)" must be followed.
- ▶ Outputs 13-14, 23-24, 33-34 are safety contacts; output 41-42 is an auxiliary contact (e.g. for display).
- ▶ Auxiliary contact 41-42 and semiconductor output Y32 should **not** be used for safety circuits!
- ▶ To prevent contact welding, a fuse should be connected before the output contacts (see [Technical details \[596\]](#)).
- ▶ Calculation of the max. cable length l_{\max} in the input circuit:

$$l_{\max} = \frac{R_{l\max}}{R_l / \text{km}}$$

$R_{l\max}$ = max. overall cable resistance (see [Technical details \[596\]](#))

R_l / km = cable resistance/km

- ▶ Use copper wire that can withstand 60/75 °C.
- ▶ Sufficient fuse protection must be provided on all output contacts with capacitive and inductive loads.
- ▶ With U_B 48 – 240 VAC/DC: Connect S21 to the functional earth.
- ▶ When connecting magnetically operated, reed proximity switches, ensure that the max. peak inrush current (on the input circuit) does not overload the proximity switch.
- ▶ Ensure the wiring and EMC requirements of IEC 60204-1 are met.

Safety relays PNOZsigma PNOZ s4

- ▶ On 24 VDC devices:
The power supply must comply with the regulations for extra low voltages with protective electrical separation (SELV, PELV) in accordance with VDE 0100, Part 410.

Preparing for operation

Operating modes

The operating mode is set via the rotary switch on the unit. You can do this by opening the cover on the front of the unit.

Set operating modes

- ▶ Switch off supply voltage.
- ▶ Select operating mode via the operating mode selector switch "mode".
- ▶ If the operating mode selector switch "mode" is in its start position (vertical position), an error message will appear.

| Operating mode selector switch "mode" | Automatic or manual start | Monitored start rising edge | Monitored start falling edge | Automatic start with start-up test |
|---|---------------------------|-----------------------------|------------------------------|------------------------------------|
| Without detection of shorts across contacts | | | | |
| With detection of shorts across contacts | | | | |

Safety relays PNOZsigma PNOZ s4

Connection

| Supply voltage | Unit types with U_B 24 VDC | Unit types with U_B 48 - 240 VAC/DC |
|--|------------------------------|---------------------------------------|
| | | |
| Input circuit | Single-channel | Dual-channel |
| E-Stop without detection of shorts across contacts | | |
| E-Stop with detection of shorts across contacts | / | |
| Safety gate without detection of shorts across contacts | | |
| Safety gate with detection of shorts across contacts | / | |
| Light beam device or safety switch, detection of shorts across contacts via ESPE (only for unit types with $U_B = 24$ VDC) | / | |

Safety relays PNOZsigma PNOZ s4

| Start circuit/feedback loop | Without feedback loop monitoring | With feedback loop monitoring |
|---|--|-------------------------------|
| Automatic start | | |
| Monitored, manual start/restart | | |
| Unit types with U _B 24 VDC | Unit types with U _B 48 - 240 VAC/DC | |
| | | |
| *Connect together the 0V connections on all the external power supplies | | |

Legend

- ▶ S1/S2: E-STOP/safety gate switch
- ▶ S3: Reset button
- ▶ ↑: Switch operated
- ▶ : Gate open
- ▶ : Gate closed

Safety relays PNOZsigma PNOZ s4

Dimensions in mm

*with spring-loaded terminals

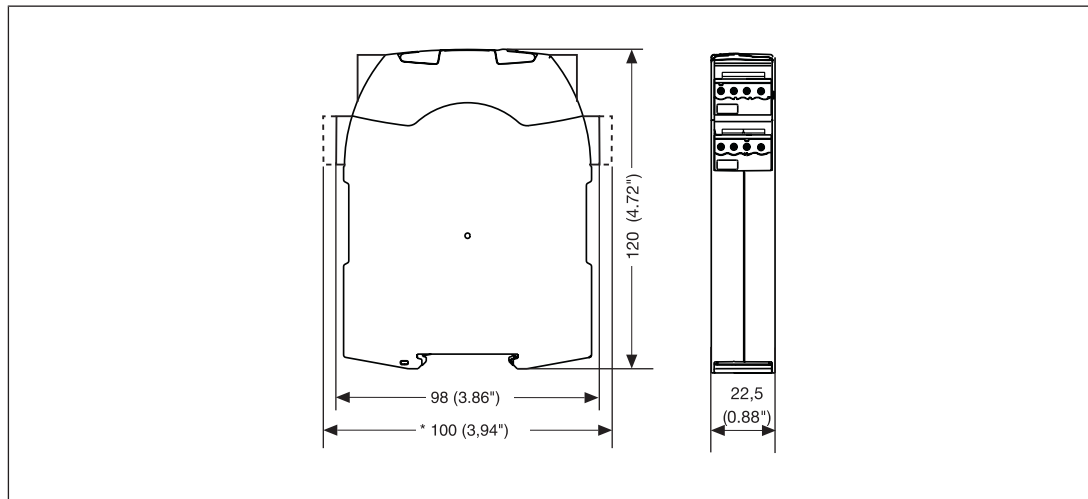

Technical details

Order no. 750104 – 751104

See below for more order numbers

| General | 750104 | 750134 | 751104 |
|--------------------------------------|---|---|---|
| Approvals | CCC, CE, EAC (Eurasian), KOSHA, TÜV, cULus Listed | CCC, CE, EAC (Eurasian), KOSHA, TÜV, cULus Listed | CCC, CE, EAC (Eurasian), KOSHA, TÜV, cULus Listed |
| Electrical data | 750104 | 750134 | 751104 |
| Supply voltage | | | |
| Voltage | 24 V | 48 - 240 V | 24 V |
| Kind | DC | AC/DC | DC |
| Voltage tolerance | -15 %/+10 % | -15 %/+10 % | -15 %/+10 % |
| Output of external power supply (AC) | – | 5 VA | – |
| Output of external power supply (DC) | 2,5 W | 2,5 W | 2,5 W |
| Frequency range AC | – | 50 - 60 Hz | – |
| Residual ripple DC | 20 % | 160 % | 20 % |
| Duty cycle | 100 % | 100 % | 100 % |

Safety relays PNOZsigma PNOZ s4

| Electrical data | 750104 | 750134 | 751104 |
|-----------------------------------|---------|---------|---------|
| Max. inrush current impulse | | | |
| Current pulse, A1 | 0,5 A | – | 0,5 A |
| Pulse duration, A1 | 5 ms | – | 5 ms |
| Inputs | 750104 | 750134 | 751104 |
| Number | 2 | 2 | 2 |
| Voltage at | | | |
| Input circuit DC | 24 V | 24 V | 24 V |
| Start circuit DC | 24 V | 24 V | 24 V |
| Feedback loop DC | 24 V | 24 V | 24 V |
| Current at | | | |
| Input circuit DC | 50 mA | 50 mA | 50 mA |
| Start circuit DC | 50 mA | 50 mA | 50 mA |
| Feedback loop DC | 50 mA | 50 mA | 50 mA |
| Max. inrush current impulse | | | |
| Current pulse, input circuit | 0,2 A | 0,2 A | 0,2 A |
| Pulse duration, input circuit | 100 ms | 100 ms | 100 ms |
| Current pulse, feedback loop | 0,2 A | 0,2 A | 0,2 A |
| Pulse duration, feedback loop | 15 ms | 15 ms | 15 ms |
| Current pulse, start circuit | 0,2 A | 0,2 A | 0,2 A |
| Pulse duration, start circuit | 15 ms | 15 ms | 15 ms |
| Min. input resistance at power-on | 110 Ohm | 110 Ohm | 110 Ohm |

Safety relays PNOZsigma PNOZ s4

| Inputs | 750104 | 750134 | 751104 |
|---|--------------|--------------|--------------|
| Max. overall cable resistance R _{lmax} | | | |
| Single-channel at UB DC | 30 Ohm | 30 Ohm | 30 Ohm |
| Single-channel at UB AC | – | 30 Ohm | – |
| Dual-channel without detection of shorts across contacts at UB DC | 60 Ohm | 30 Ohm | 60 Ohm |
| Dual-channel without detection of shorts across contacts at UB AC | – | 30 Ohm | – |
| Dual-channel with detection of shorts across contacts at UB DC | 30 Ohm | 30 Ohm | 30 Ohm |
| Dual-channel with detection of shorts across contacts at UB AC | – | 30 Ohm | – |
| Semiconductor outputs | 750104 | 750134 | 751104 |
| Number | 1 | 1 | 1 |
| Voltage | 24 V | 24 V | 24 V |
| Current | 20 mA | 20 mA | 20 mA |
| Relay outputs | 750104 | 750134 | 751104 |
| Number of output contacts | | | |
| Safety contacts (N/O), instantaneous | 3 | 3 | 3 |
| Auxiliary contacts (N/C) | 1 | 1 | 1 |
| Max. short circuit current I _K | 1 kA | 1 kA | 1 kA |
| Utilisation category | | | |
| In accordance with the standard | EN 60947-4-1 | EN 60947-4-1 | EN 60947-4-1 |
| Utilisation category of safety contacts | | | |
| AC1 at | 240 V | 240 V | 240 V |
| Min. current | 0,01 A | 0,01 A | 0,01 A |
| Max. current | 6 A | 6 A | 6 A |
| Max. power | 1500 VA | 1500 VA | 1500 VA |
| DC1 at | 24 V | 24 V | 24 V |
| Min. current | 0,01 A | 0,01 A | 0,01 A |
| Max. current | 6 A | 6 A | 6 A |
| Max. power | 150 W | 150 W | 150 W |

Safety relays PNOZsigma PNOZ s4

| Relay outputs | 750104 | 750134 | 751104 |
|---|--------------------------------------|--------------------------------------|--------------------------------------|
| Utilisation category of auxiliary contacts | | | |
| AC1 at | 240 V | 240 V | 240 V |
| Min. current | 0,01 A | 0,01 A | 0,01 A |
| Max. current | 6 A | 6 A | 6 A |
| Max. power | 1500 VA | 1500 VA | 1500 VA |
| DC1 at | 24 V | 24 V | 24 V |
| Min. current | 0,01 A | 0,01 A | 0,01 A |
| Max. current | 6 A | 6 A | 6 A |
| Max. power | 150 W | 150 W | 150 W |
| Utilisation category | | | |
| In accordance with the standard | EN 60947-5-1 | EN 60947-5-1 | EN 60947-5-1 |
| Utilisation category of safety contacts | | | |
| AC15 at | 230 V | 230 V | 230 V |
| Max. current | 5 A | 3 A | 5 A |
| DC13 (6 cycles/min) at | 24 V | 24 V | 24 V |
| Max. current | 5 A | 4 A | 5 A |
| Utilisation category of auxiliary contacts | | | |
| AC15 at | 230 V | 230 V | 230 V |
| Max. current | 5 A | 3 A | 5 A |
| DC13 (6 cycles/min) at | 24 V | 24 V | 24 V |
| Max. current | 5 A | 4 A | 5 A |
| Utilisation category in accordance with UL | | | |
| Voltage | 240 V AC G.U. (same polarity) | 240 V AC G.U. (same polarity) | 240 V AC G.U. (same polarity) |
| With current | 6 A | 6 A | 6 A |
| Voltage | 24 V DC G. U. | 24 V DC G. U. | 24 V DC G. U. |
| With current | 6 A | 6 A | 6 A |
| External contact fuse protection, safety contacts | | | |
| In accordance with the standard | EN 60947-5-1 | EN 60947-5-1 | EN 60947-5-1 |
| Max. melting integral | 260 A²s | 66 A²s | 260 A²s |
| Blow-out fuse, quick | 10 A | 6 A | 10 A |
| Blow-out fuse, slow | 6 A | 4 A | 6 A |
| Blow-out fuse, gG | 10 A | 6 A | 10 A |
| Circuit breaker 24V AC/DC, characteristic B/C | 6 A | 4 A | 6 A |

Safety relays PNOZsigma PNOZ s4

| Relay outputs | 750104 | 750134 | 751104 |
|--|---------------------------|---------------------------|---------------------------|
| External contact fuse protection, auxiliary contacts | | | |
| Max. melting integral | 160 A²s | 66 A²s | 160 A²s |
| Blow-out fuse, quick | 10 A | 6 A | 10 A |
| Blow-out fuse, slow | 6 A | 4 A | 6 A |
| Blow-out fuse, gG | 6 A | 6 A | 6 A |
| Circuit breaker 24 V AC/DC, characteristic B/C | 6 A | 4 A | 6 A |
| Contact material | AgCuNi + 0,2 µm Au | AgCuNi + 0,2 µm Au | AgCuNi + 0,2 µm Au |
| Conventional thermal current while loading several contacts | 750104 | 750134 | 751104 |
| Ith per contact at UB AC; AC1: 240 V, DC1: 24 V | | | |
| Conv. therm. current with 1 contact | – | 6 A | – |
| Conv. therm. current with 2 contacts | – | 6 A | – |
| Conv. therm. current with 3 contacts | – | 4,5 A | – |
| Ith per contact at UB DC; AC1: 240 V, DC1: 24 V | | | |
| Conv. therm. current with 1 contact | 6 A | 6 A | 6 A |
| Conv. therm. current with 2 contacts | 6 A | 6 A | 6 A |
| Conv. therm. current with 3 contacts | 5 A | 4,5 A | 5 A |

Safety relays PNOZsigma PNOZ s4

| Times | 750104 | 750134 | 751104 |
|--|---------------|---------------|---------------|
| Switch-on delay | | | |
| With automatic start typ. | 170 ms | 170 ms | 170 ms |
| With automatic start max. | 300 ms | 300 ms | 300 ms |
| With automatic start after power on typ. | 350 ms | 350 ms | 350 ms |
| With automatic start after power on max. | 600 ms | 600 ms | 600 ms |
| With manual start typ. | 40 ms | 40 ms | 40 ms |
| With monitored start with rising edge typ. | 35 ms | 35 ms | 35 ms |
| With monitored start with rising edge max. | 50 ms | 50 ms | 50 ms |
| With monitored start with falling edge typ. | 55 ms | 55 ms | 55 ms |
| With monitored start with falling edge max. | 70 ms | 70 ms | 70 ms |
| Delay-on de-energisation | | | |
| With E-STOP typ. | 10 ms | 10 ms | 10 ms |
| With E-STOP max. | 20 ms | 20 ms | 20 ms |
| With power failure typ. | 40 ms | 40 ms | 40 ms |
| With power failure max. | 80 ms | 80 ms | 80 ms |
| Recovery time at max. switching frequency 1/s | | | |
| After E-STOP | 100 ms | 50 ms | 100 ms |
| After power failure | 100 ms | 100 ms | 100 ms |
| Waiting period with a monitored start | | | |
| With rising edge | 120 ms | 120 ms | 120 ms |
| With falling edge | 250 ms | 150 ms | 250 ms |
| Min. start pulse duration with a monitored start | | | |
| With rising edge | 30 ms | 30 ms | 30 ms |
| With falling edge | 100 ms | 100 ms | 100 ms |
| Supply interruption before de-energisation | 20 ms | 20 ms | 20 ms |
| Simultaneity, channel 1 and 2 max. | ∞ | ∞ | ∞ |
| Environmental data | 750104 | 750134 | 751104 |
| Climatic suitability | EN 60068-2-78 | EN 60068-2-78 | EN 60068-2-78 |
| Ambient temperature | | | |
| Temperature range | -10 - 55 °C | -10 - 55 °C | -10 - 55 °C |

Safety relays PNOZsigma PNOZ s4

| Environmental data | 750104 | 750134 | 751104 |
|--------------------------------------|---|---|---|
| Storage temperature | | | |
| Temperature range | -40 - 85 °C | -40 - 85 °C | -40 - 85 °C |
| Climatic suitability | | | |
| Humidity | 93 % r. h. at 40 °C | 93 % r. h. at 40 °C | 93 % r. h. at 40 °C |
| Condensation during operation | Not permitted | Not permitted | Not permitted |
| EMC | EN 60947-5-1, EN 61000-6-2, EN 61000-6-4, EN 61326-3-1 | EN 60947-5-1, EN 61000-6-2, EN 61000-6-4, EN 61326-3-1 | EN 60947-5-1, EN 61000-6-2, EN 61000-6-4, EN 61326-3-1 |
| Vibration | | | |
| In accordance with the standard | EN 60068-2-6 | EN 60068-2-6 | EN 60068-2-6 |
| Frequency | 10 - 55 Hz | 10 - 55 Hz | 10 - 55 Hz |
| Amplitude | 0,35 mm | 0,35 mm | 0,35 mm |
| Airgap creepage | | | |
| In accordance with the standard | EN 60947-1 | EN 60947-1 | EN 60947-1 |
| Overvoltage category | III / II | III / II | III / II |
| Pollution degree | 2 | 2 | 2 |
| Rated insulation voltage | 250 V | 250 V | 250 V |
| Rated impulse withstand voltage | 4 kV | 4 kV | 4 kV |
| Protection type | | | |
| Mounting area (e.g. control cabinet) | IP54 | IP54 | IP54 |
| Housing | IP40 | IP40 | IP40 |
| Terminals | IP20 | IP20 | IP20 |
| Mechanical data | 750104 | 750134 | 751104 |
| Mounting position | Any | Any | Any |
| Mechanical life | 10,000,000 cycles | 10,000,000 cycles | 10,000,000 cycles |
| Material | | | |
| Bottom | PC | PC | PC |
| Front | PC | PC | PC |
| Top | PC | PC | PC |
| Connection type | Screw terminal | Screw terminal | Spring-loaded terminal |
| Mounting type | plug-in | plug-in | plug-in |

Safety relays PNOZsigma PNOZ s4

| Mechanical data | 750104 | 750134 | 751104 |
|---|---|---|--|
| Conductor cross section with screw terminals | | | |
| 1 core flexible | 0,25 - 2,5 mm², 24 - 12 AWG | 0,25 - 2,5 mm², 24 - 12 AWG | – |
| 2 core with the same cross section, flexible with crimp connectors, no plastic sleeve | 0,25 - 1 mm², 24 - 16 AWG | 0,25 - 1 mm², 24 - 16 AWG | – |
| 2 core with the same cross section, flexible without crimp connectors or with TWIN crimp connectors | 0,2 - 1,5 mm², 24 - 16 AWG | 0,2 - 1,5 mm², 24 - 16 AWG | – |
| Torque setting with screw terminals | 0,5 Nm | 0,5 Nm | – |
| Conductor cross section with spring-loaded terminals: Flexible with/without crimp connector | – | – | 0,2 - 2,5 mm², 24 - 12 AWG |
| Spring-loaded terminals: Terminal points per connection | – | – | 2 |
| Stripping length with spring-loaded terminals | – | – | 9 mm |
| Dimensions | | | |
| Height | 98 mm | 98 mm | 100 mm |
| Width | 22,5 mm | 22,5 mm | 22,5 mm |
| Depth | 120 mm | 120 mm | 120 mm |
| Weight | 190 g | 210 g | 190 g |

Safety relays PNOZsigma PNOZ s4

Order no. 751134 – 751184

| General | 751134 | 751184 |
|--------------------------------------|--|--|
| Approvals | CCC, CE, EAC (Eurasian), KOSHA, TÜV, cULus Listed | CCC, CE, EAC (Eurasian), KOSHA, TÜV, cULus Listed |
| Electrical data | 751134 | 751184 |
| Supply voltage | | |
| Voltage | 48 - 240 V | 24 V |
| Kind | AC/DC | DC |
| Voltage tolerance | -15 %/+10 % | -15 %/+10 % |
| Output of external power supply (AC) | 5 VA | – |
| Output of external power supply (DC) | 2,5 W | 2,5 W |
| Frequency range AC | 50 - 60 Hz | – |
| Residual ripple DC | 160 % | 20 % |
| Duty cycle | 100 % | 100 % |
| Max. inrush current impulse | | |
| Current pulse, A1 | – | 0,5 A |
| Pulse duration, A1 | – | 5 ms |
| Inputs | 751134 | 751184 |
| Number | 2 | 2 |
| Voltage at | | |
| Input circuit DC | 24 V | 24 V |
| Start circuit DC | 24 V | 24 V |
| Feedback loop DC | 24 V | 24 V |
| Current at | | |
| Input circuit DC | 50 mA | 50 mA |
| Start circuit DC | 50 mA | 50 mA |
| Feedback loop DC | 50 mA | 50 mA |
| Max. inrush current impulse | | |
| Current pulse, input circuit | 0,2 A | 0,2 A |
| Pulse duration, input circuit | 100 ms | 100 ms |
| Current pulse, feedback loop | 0,2 A | 0,2 A |
| Pulse duration, feedback loop | 15 ms | 15 ms |
| Current pulse, start circuit | 0,2 A | 0,2 A |
| Pulse duration, start circuit | 15 ms | 15 ms |
| Min. input resistance at power-on | 110 Ohm | 110 Ohm |

Safety relays PNOZsigma PNOZ s4

| Inputs | 751134 | 751184 |
|---|---------------------|---------------------|
| Max. overall cable resistance RI-max | | |
| Single-channel at UB DC | 30 Ohm | 30 Ohm |
| Single-channel at UB AC | 30 Ohm | – |
| Dual-channel without detection of shorts across contacts at UB DC | 30 Ohm | 60 Ohm |
| Dual-channel without detection of shorts across contacts at UB AC | 30 Ohm | – |
| Dual-channel with detection of shorts across contacts at UB DC | 30 Ohm | 30 Ohm |
| Dual-channel with detection of shorts across contacts at UB AC | 30 Ohm | – |
| Semiconductor outputs | 751134 | 751184 |
| Number | 1 | 1 |
| Voltage | 24 V | 24 V |
| Current | 20 mA | 20 mA |
| Relay outputs | 751134 | 751184 |
| Number of output contacts | | |
| Safety contacts (N/O), instantaneous | 3 | 3 |
| Auxiliary contacts (N/C) | 1 | 1 |
| Max. short circuit current IK | 1 kA | 1 kA |
| Utilisation category | | |
| In accordance with the standard | EN 60947-4-1 | EN 60947-4-1 |
| Utilisation category of safety contacts | | |
| AC1 at | 240 V | 240 V |
| Min. current | 0,01 A | 0,01 A |
| Max. current | 6 A | 6 A |
| Max. power | 1500 VA | 1500 VA |
| DC1 at | 24 V | 24 V |
| Min. current | 0,01 A | 0,01 A |
| Max. current | 6 A | 6 A |
| Max. power | 150 W | 150 W |

Safety relays PNOZsigma PNOZ s4

| Relay outputs | 751134 | 751184 |
|---|-------------------------------|-------------------------------|
| Utilisation category of auxiliary contacts | | |
| AC1 at | 240 V | 240 V |
| Min. current | 0,01 A | 0,01 A |
| Max. current | 6 A | 6 A |
| Max. power | 1500 VA | 1500 VA |
| DC1 at | 24 V | 24 V |
| Min. current | 0,01 A | 0,01 A |
| Max. current | 6 A | 6 A |
| Max. power | 150 W | 150 W |
| Utilisation category | | |
| In accordance with the standard | EN 60947-5-1 | EN 60947-5-1 |
| Utilisation category of safety contacts | | |
| AC15 at | 230 V | 230 V |
| Max. current | 3 A | 5 A |
| DC13 (6 cycles/min) at | 24 V | 24 V |
| Max. current | 4 A | 5 A |
| Utilisation category of auxiliary contacts | | |
| AC15 at | 230 V | 230 V |
| Max. current | 3 A | 5 A |
| DC13 (6 cycles/min) at | 24 V | 24 V |
| Max. current | 4 A | 5 A |
| Utilisation category in accordance with UL | | |
| Voltage | 240 V AC G.U. (same polarity) | 240 V AC G.U. (same polarity) |
| With current | 6 A | 6 A |
| Voltage | 24 V DC G. U. | 24 V DC G. U. |
| With current | 6 A | 6 A |
| External contact fuse protection, safety contacts | | |
| In accordance with the standard | EN 60947-5-1 | EN 60947-5-1 |
| Max. melting integral | 66 A ² s | 260 A ² s |
| Blow-out fuse, quick | 6 A | 10 A |
| Blow-out fuse, slow | 4 A | 6 A |
| Blow-out fuse, gG | 6 A | 10 A |
| Circuit breaker 24V AC/DC, characteristic B/C | 4 A | 6 A |

Safety relays PNOZsigma PNOZ s4

| Relay outputs | 751134 | 751184 |
|--|---------------------------|---------------------------|
| External contact fuse protection, auxiliary contacts | | |
| Max. melting integral | 66 A²s | 160 A²s |
| Blow-out fuse, quick | 6 A | 10 A |
| Blow-out fuse, slow | 4 A | 6 A |
| Blow-out fuse, gG | 6 A | 6 A |
| Circuit breaker 24 V AC/DC, characteristic B/C | 4 A | 6 A |
| Contact material | AgCuNi + 0,2 µm Au | AgCuNi + 0,2 µm Au |
| Conventional thermal current while loading several contacts | 751134 | 751184 |
| I _{th} per contact at UB AC; AC1: 240 V, DC1: 24 V | | |
| Conv. therm. current with 1 contact | 6 A | – |
| Conv. therm. current with 2 contacts | 6 A | – |
| Conv. therm. current with 3 contacts | 4,5 A | – |
| I _{th} per contact at UB DC; AC1: 240 V, DC1: 24 V | | |
| Conv. therm. current with 1 contact | 6 A | 6 A |
| Conv. therm. current with 2 contacts | 6 A | 6 A |
| Conv. therm. current with 3 contacts | 4,5 A | 5 A |
| Times | 751134 | 751184 |
| Switch-on delay | | |
| With automatic start typ. | 170 ms | 170 ms |
| With automatic start max. | 300 ms | 300 ms |
| With automatic start after power on typ. | 350 ms | 350 ms |
| With automatic start after power on max. | 600 ms | 600 ms |
| With manual start typ. | 40 ms | 40 ms |
| With monitored start with rising edge typ. | 35 ms | 35 ms |
| With monitored start with rising edge max. | 50 ms | 50 ms |
| With monitored start with falling edge typ. | 55 ms | 55 ms |
| With monitored start with falling edge max. | 70 ms | 70 ms |

Safety relays PNOZsigma PNOZ s4

| Times | 751134 | 751184 |
|--|---|---|
| Delay-on de-energisation | | |
| With E-STOP typ. | 10 ms | 10 ms |
| With E-STOP max. | 20 ms | 20 ms |
| With power failure typ. | 40 ms | 40 ms |
| With power failure max. | 80 ms | 80 ms |
| Recovery time at max. switching frequency 1/s | | |
| After E-STOP | 50 ms | 100 ms |
| After power failure | 100 ms | 100 ms |
| Waiting period with a monitored start | | |
| With rising edge | 120 ms | 120 ms |
| With falling edge | 150 ms | 250 ms |
| Min. start pulse duration with a monitored start | | |
| With rising edge | 30 ms | 30 ms |
| With falling edge | 100 ms | 100 ms |
| Supply interruption before de-energisation | 20 ms | 20 ms |
| Simultaneity, channel 1 and 2 max. | ∞ | ∞ |
| Environmental data | 751134 | 751184 |
| Climatic suitability | EN 60068-2-78 | EN 60068-2-78 |
| Ambient temperature | | |
| Temperature range | -10 - 55 °C | -25 - 55 °C |
| Storage temperature | | |
| Temperature range | -40 - 85 °C | -40 - 85 °C |
| Climatic suitability | | |
| Humidity | 93 % r. h. at 40 °C | 93 % r. h. at 40 °C |
| Condensation during operation | Not permitted | Not permitted |
| EMC | EN 60947-5-1, EN 61000-6-2, EN 61000-6-4, EN 61326-3-1 | EN 60947-5-1, EN 61000-6-2, EN 61000-6-4, EN 61326-3-1 |
| Vibration | | |
| In accordance with the standard | EN 60068-2-6 | EN 60068-2-6 |
| Frequency | 10 - 55 Hz | 10 - 55 Hz |
| Amplitude | 0,35 mm | 0,35 mm |
| Airgap creepage | | |
| In accordance with the standard | EN 60947-1 | EN 60947-1 |
| Overvoltage category | III / II | III / II |
| Pollution degree | 2 | 2 |
| Rated insulation voltage | 250 V | 250 V |
| Rated impulse withstand voltage | 4 kV | 4 kV |

Safety relays PNOZsigma PNOZ s4

| Environmental data | 751134 | 751184 |
|---|---|---|
| Protection type | | |
| Mounting area (e.g. control cabinet) | IP54 | IP54 |
| Housing | IP40 | IP40 |
| Terminals | IP20 | IP20 |
| Mechanical data | 751134 | 751184 |
| Mounting position | Any | Any |
| Mechanical life | 10,000,000 cycles | 10,000,000 cycles |
| Material | | |
| Bottom | PC | PC |
| Front | PC | PC |
| Top | PC | PC |
| Connection type | Spring-loaded terminal | Spring-loaded terminal |
| Mounting type | plug-in | plug-in |
| Conductor cross section with spring-loaded terminals: Flexible with/without crimp connector | 0,2 - 2,5 mm ² , 24 - 12 AWG | 0,2 - 2,5 mm ² , 24 - 12 AWG |
| Spring-loaded terminals: Terminal points per connection | 2 | 2 |
| Stripping length with spring-loaded terminals | 9 mm | 9 mm |
| Dimensions | | |
| Height | 100 mm | 100 mm |
| Width | 22,5 mm | 22,5 mm |
| Depth | 120 mm | 120 mm |
| Weight | 210 g | 190 g |

Where standards are undated, the 2014-07 latest editions shall apply.

Safety characteristic data

| Operating Mode | EN ISO 13849-1: 2015 | EN ISO 13849-1: 2015 | EN 62061 SIL CL | EN 62061 PFH _D [1/h] | IEC 61511 SIL | IEC 61511 PFD | EN ISO 13849-1: 2015 T _M [year] |
|----------------|----------------------|----------------------|-----------------|---------------------------------|---------------|---------------|--|
| PL | PL e | Category | | | | | |

Safety contacts, instantaneous

PL e Cat. 4 SIL CL 3 2,31E-09 SIL 3 2,03E-06 20

All the units used within a safety function must be considered when calculating the safety characteristic data.

Safety relays PNOZsigma PNOZ s4

Supplementary data

The PFH value depends on the switching frequency and the load on the relay output. If the service life graphs are not accessible, the stated PFH value can be used irrespective of the switching frequency and the load, as the PFH value already considers the relay's B10d value as well as the failure rates of the other components.

Service life graph

The service life graphs indicate the number of cycles from which failures due to wear must be expected. The wear is mainly caused by the electrical load; the mechanical load is negligible.

Unit types with UB 24 VDC

- ▶ U_B : 24 VDC; Order no. 750104, 751104, 751184

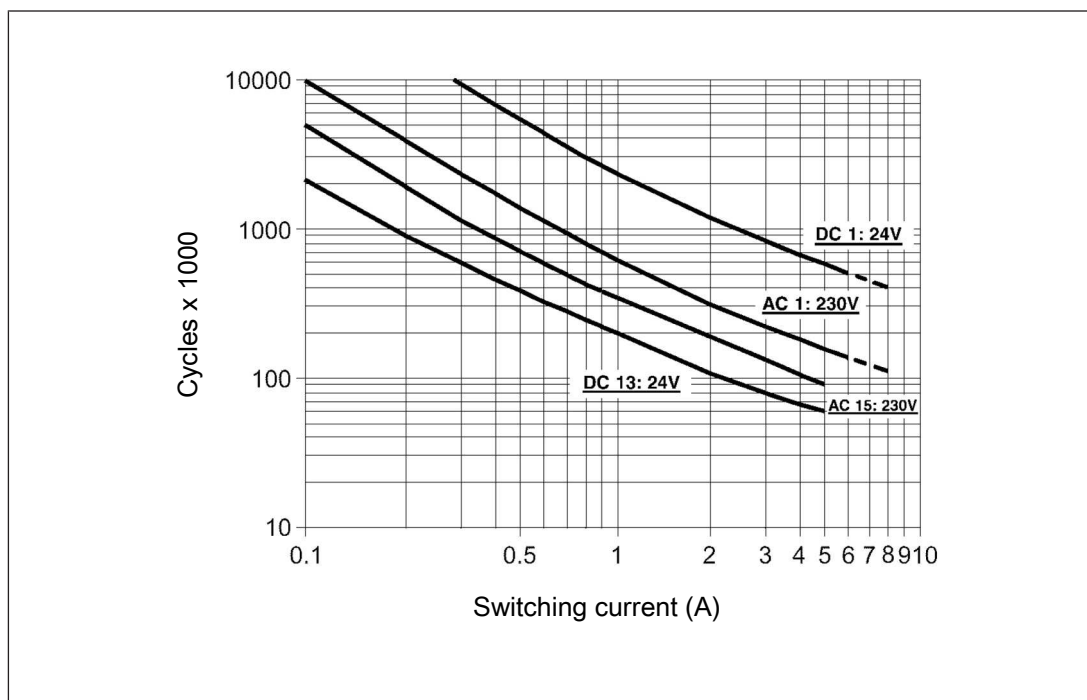

Fig.: Service life graphs at 24 VDC and 230 VAC

Safety relays PNOZsigma PNOZ s4

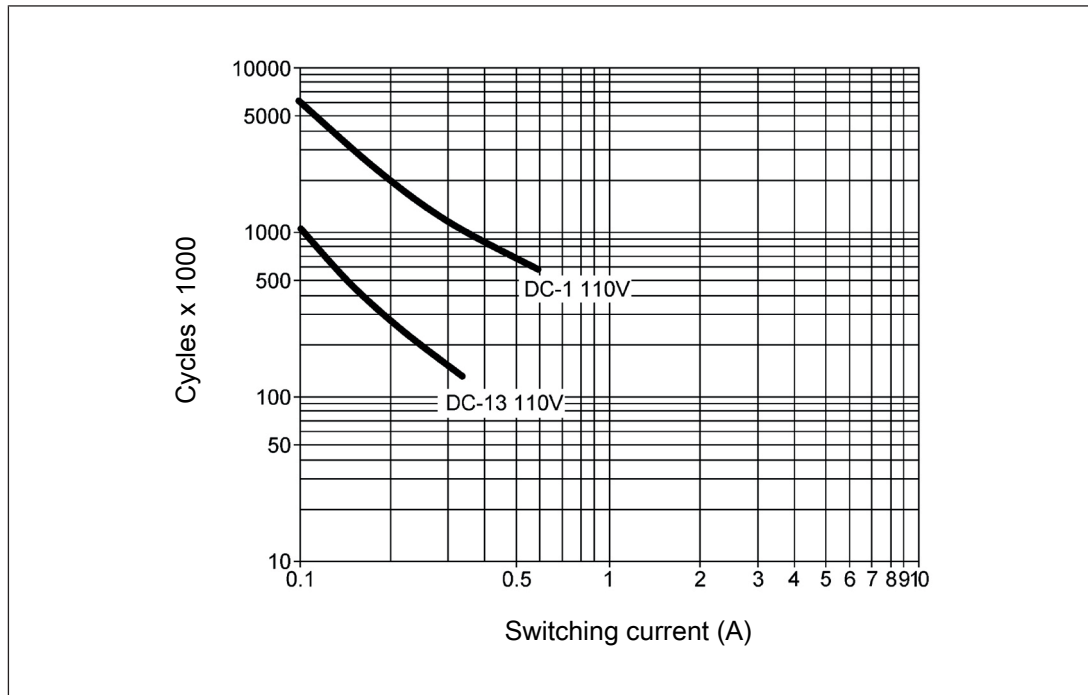

Fig.: Service life graphs at 110 VDC

Example

- ▶ Inductive load: 0.2 A
- ▶ Utilisation category: AC15
- ▶ Contact service life: 2 000 000 cycles

Provided the application to be implemented requires fewer than 2 000 000 cycles, the PFH value (see [Technical details \[596\]](#)) can be used in the calculation.

To increase the service life, sufficient spark suppression must be provided on all output contacts. With capacitive loads, any power surges that occur must be noted. With DC contactors, use flywheel diodes for spark suppression.

Safety relays PNOZsigma PNOZ s4

Unit types with UB 48-240 VAC/DC

▶ U_B : 48 – 240 VAC/DC; Order no. 750134, 751134

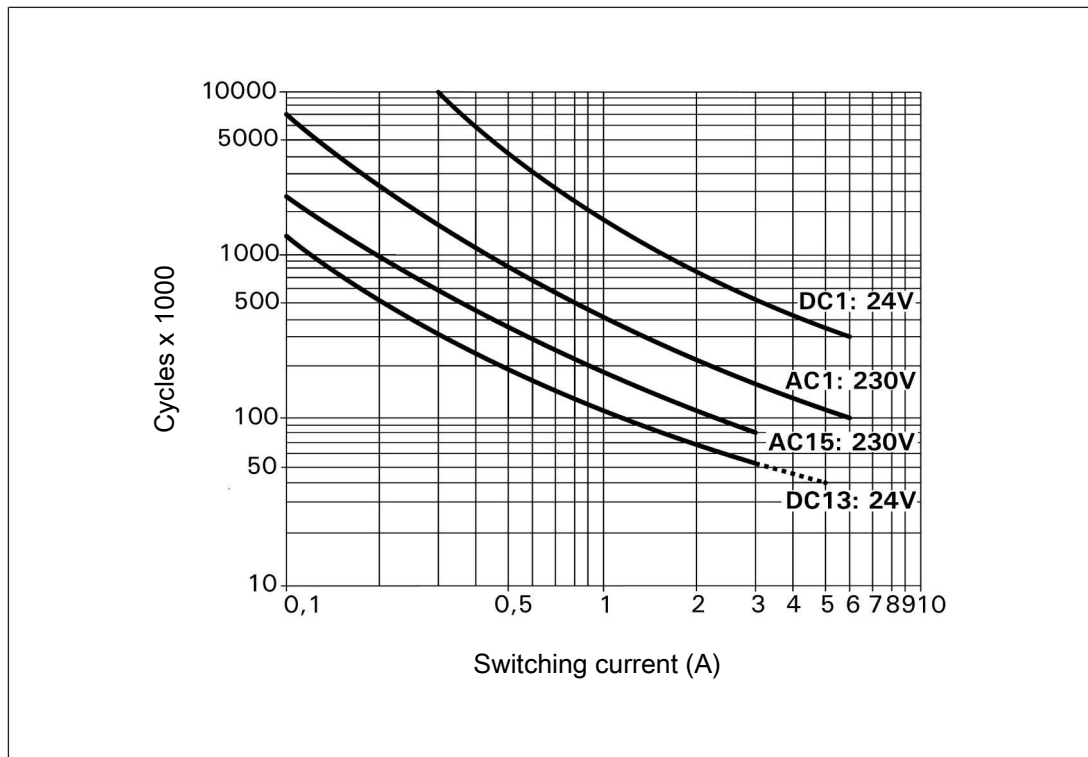

Fig.: Service life graphs at 24 VDC and 230 VAC

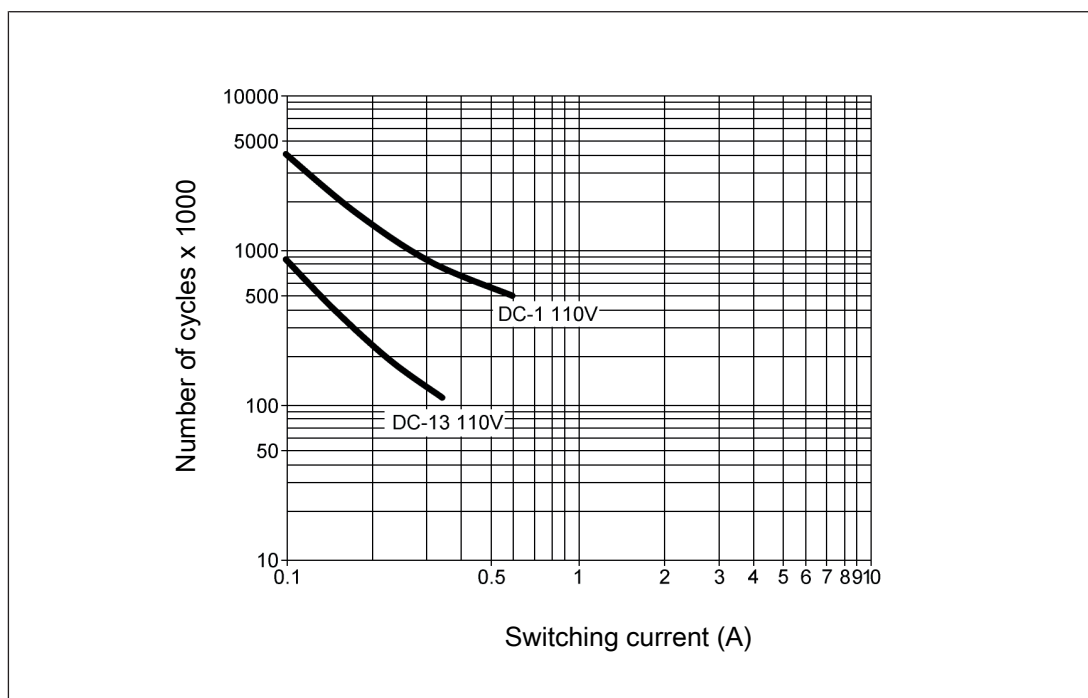

Fig.: Service life graphs at 110 VDC

Safety relays PNOZsigma PNOZ s4

Example

- ▶ Inductive load: 0.2 A
- ▶ Utilisation category: AC15
- ▶ Contact service life: 1 000 000 cycles

Provided the application to be implemented requires fewer than 1 000 000 cycles, the PFH value (see [Technical details \[596\]](#)) can be used in the calculation.

To increase the service life, sufficient spark suppression must be provided on all relay contacts. With capacitive loads, any power surges that occur must be noted. With DC contactors, use flywheel diodes for spark suppression.

Order reference

| Product type | Features | Connection type | Order No. |
|---------------------|-----------------|-------------------------|-----------|
| PNOZ s4 | 24 VDC | Screw terminals | 750 104 |
| PNOZ s4 | 48 – 240 VAC/DC | Screw terminals | 750 134 |
| PNOZ s4 C | 24 VDC | Spring-loaded terminals | 751 104 |
| PNOZ s4 C | 48 – 240 VAC/DC | Spring-loaded terminals | 751 134 |
| PNOZ s4 C Coated | 24 VDC | Spring-loaded terminals | 751 184 |

Safety relays PNOZsigma PNOZ s4.1



Unit features

- ▶ Positive-guided relay outputs:
 - 3 safety contacts (N/O), instantaneous
 - 1 auxiliary contact (N/C), instantaneous
- ▶ 1 semiconductor output
- ▶ Connection options for:
 - E-STOP pushbuttons
 - Safety gate limit switches
 - Start buttons
 - Light grids and safety switches
 - PSEN
 - Safety valves for furnaces
- ▶ A connector can be used to connect 1 PNOZsigma contact expansion module
- ▶ Operating modes can be set via rotary switch
- ▶ LED indicator for:
 - Supply voltage
 - Input status, channel 1
 - Input status, channel 2
 - Switch status of the safety contacts
 - Start circuit
 - Errors
- ▶ Plug-in connection terminals (either spring-loaded terminal or screw terminal)
- ▶ See order reference for unit types

Safety relays PNOZsigma PNOZ s4.1

Block diagram/terminal configuration

Unit types with UB 24 VDC

- ▶ U_B : 24 VDC; Order no. 750124, 751124

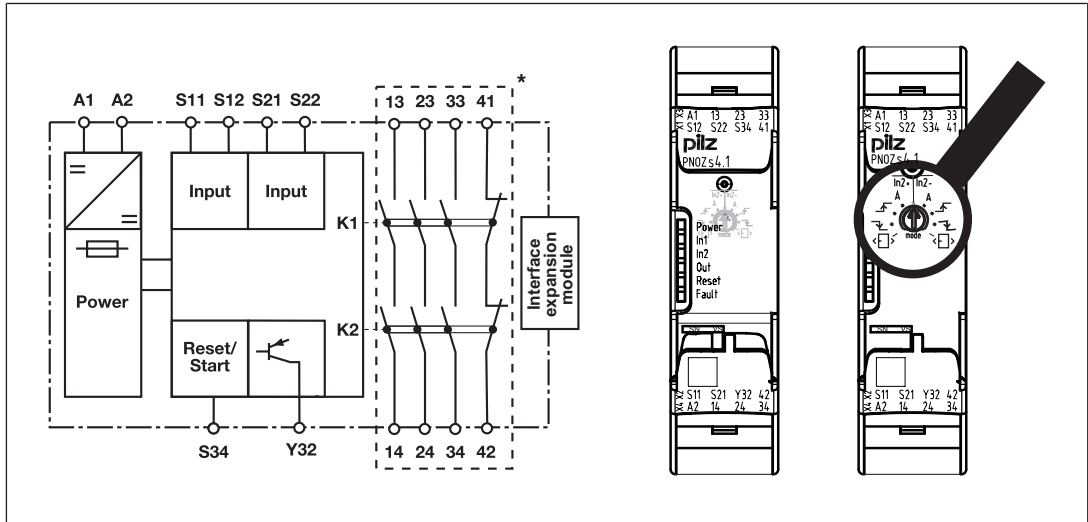

Fig.: Centre: Front view with cover, right: Front view without cover

*Insulation between the non-marked area and the relay contacts: Basic insulation (over-voltage category III), Protective separation (overvoltage category II)

Unit types with UB 48 - 240 VAC/DC

- ▶ U_B : 48 - 240 VAC/DC; Order no. 750154, 751154

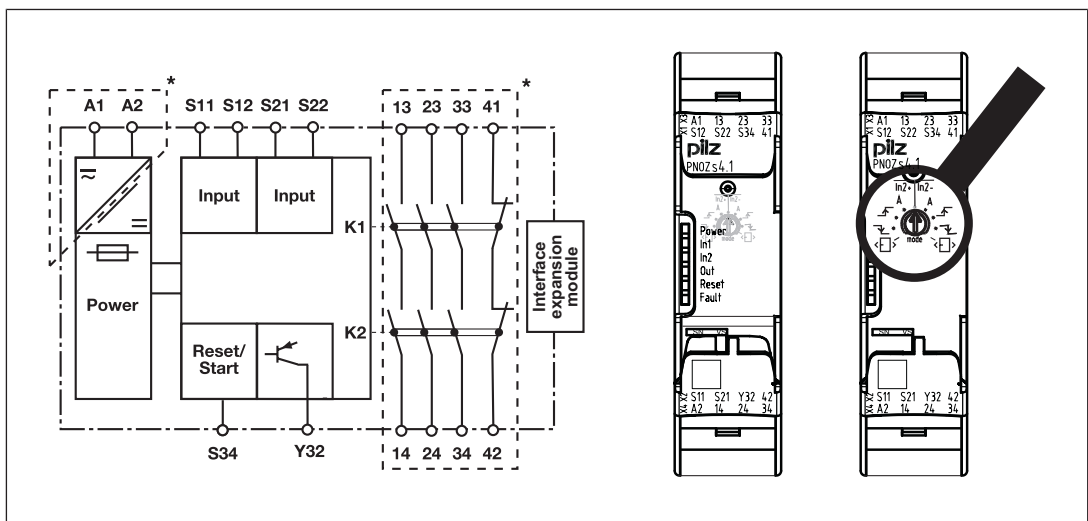

Fig.: Centre: Front view with cover, right: Front view without cover

*Insulation between the non-marked area and the relay contacts: Basic insulation (over-voltage category III), Protective separation (overvoltage category II)

Safety relays PNOZsigma PNOZ s4.1

Function description

- ▶ $\overline{\text{In}2\text{+}}$ Single-channel operation: no redundancy in the input circuit, earth faults in the start circuit and input circuit are detected.
- ▶ Dual-channel operation without detection of shorts across contacts: Redundant input circuit, detects PNOZ s4.1
 - earth faults in the start and input circuit,
 - short circuits in the input circuit and, with a monitored start, in the start circuit too.
- ▶ $\overline{\text{In}2\text{-}}$ Dual-channel operation with detection of shorts across contacts: Redundant input circuit, detects PNOZ s4.1
 - earth faults in the start and input circuit,
 - Short circuits in the input circuit and, with a monitored start, in the start circuit too,
 - Shorts across contacts in the input circuit.
- ▶ **A** Automatic start: Unit is active once the input circuit has been closed.
- ▶ Manual start Unit is active once the input circuit and the start circuit are closed.
- ▶ $\overline{\downarrow}$ Monitored start with falling edge: Unit is active once
 - the input circuit is closed and then the start circuit is closed and opened again.
 - the start circuit is closed and then opened again once the input circuit is closed.
- ▶ \uparrow Monitored start with rising edge: Unit is active once the input circuit is closed and once the start circuit is closed after the waiting period has elapsed (see technical details).
- ▶ \square Start with start-up test: The unit checks whether safety gates that are closed are opened and then closed again when supply voltage is applied.
- ▶ Increase in the number of available instantaneous safety contacts by connecting contact expander modules or external contactors/relays;
A connector can be used to connect 1 PNOZsigma contact expander module.

Safety relays PNOZsigma PNOZ s4.1

Timing diagram

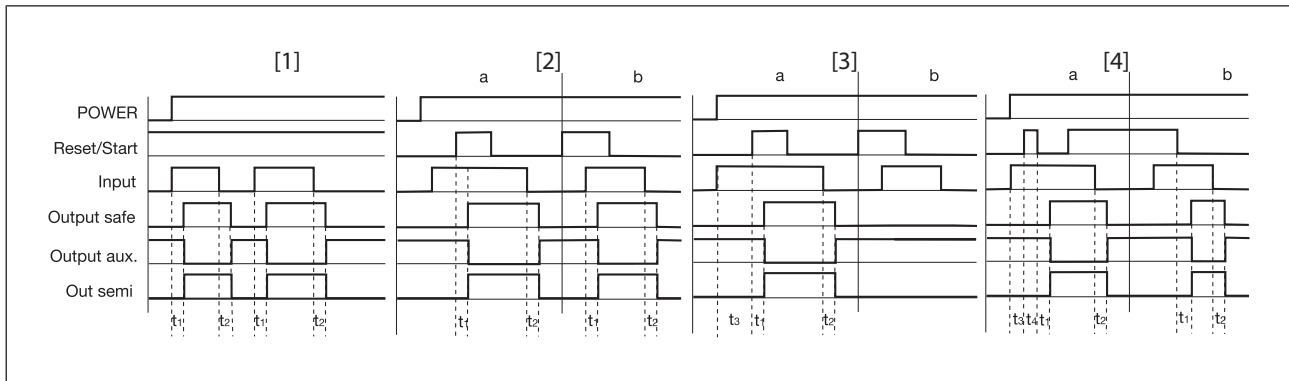

Legend

- ▶ POWER: Supply voltage
- ▶ Start: Start circuit
- ▶ Input: Input circuits
- ▶ Output safe: Safety contacts
- ▶ Output aux.: Auxiliary contacts
- ▶ Out semi: Semiconductor output
- ▶ [1]: Automatic start
- ▶ [2]: Manual start
- ▶ [3]: Monitored start with rising edge
- ▶ [4]: Monitored start with falling edge
- ▶ a: Input circuit closes before start circuit
- ▶ b: Start circuit closes before input circuit
- ▶ t_1 : Switch-on delay
- ▶ t_2 : Delay-on de-energisation
- ▶ t_3 : Waiting period with a monitored start
- ▶ t_4 : Min. start pulse duration with a monitored start

Safety relays PNOZsigma PNOZ s4.1

Installation

Install base unit without contact expansion module:

- ▶ Ensure that the plug terminator is inserted at the side of the unit.

Connect base unit and PNOZsigma contact expansion module:

- ▶ Remove the plug terminator at the side of the base unit and at the contact expansion module.
- ▶ Connect the base unit and the contact expansion module to the supplied connector before mounting the units to the DIN rail.

Installation in control cabinet

- ▶ The safety relay should be installed in a control cabinet with a protection type of at least IP54.
- ▶ Use the notch on the rear of the unit to attach it to a DIN rail (35 mm).
- ▶ When installed vertically: Secure the unit by using a fixing element (e.g. retaining bracket or end angle).
- ▶ Push the device upwards or downwards before lifting it from the DIN rail.

Wiring

Please note:

- ▶ Information given in the "[Technical details \[622\]](#)" must be followed.
- ▶ Outputs 13-14, 23-24, 33-34 are safety contacts; output 41-42 is an auxiliary contact (e.g. for display).
- ▶ Auxiliary contact 41-42 and semiconductor output Y32 should **not** be used for safety circuits!
- ▶ To prevent contact welding, a fuse should be connected before the output contacts (see [Technical details \[622\]](#)).
- ▶ Calculation of the max. cable length l_{\max} in the input circuit:

$$l_{\max} = \frac{R_{l\max}}{R_l / \text{km}}$$

$R_{l\max}$ = max. overall cable resistance (see [Technical details \[622\]](#))

R_l / km = cable resistance/km

- ▶ Use copper wire that can withstand 60/75 °C.
- ▶ Sufficient fuse protection must be provided on all output contacts with capacitive and inductive loads.
- ▶ With U_B 48 – 240 VAC/DC: Connect S21 to the functional earth.
- ▶ Ensure the wiring and EMC requirements of IEC 60204-1 are met.
- ▶ On 24 VDC devices:
The power supply must comply with the regulations for extra low voltages with protective electrical separation (SELV, PELV) in accordance with VDE 0100, Part 410.

Safety relays PNOZsigma PNOZ s4.1









Preparing for operation

Operating modes

The operating mode is set via the rotary switch on the unit. You can do this by opening the cover on the front of the unit.

Set operating modes

- ▶ Switch off supply voltage.
- ▶ Select operating mode via the operating mode selector switch "mode".
- ▶ If the operating mode selector switch "mode" is in its start position (vertical position), an error message will appear.

| Operating mode selector switch "mode" | Automatic or manual start | Monitored start rising edge | Monitored start falling edge | Automatic start with start-up test |
|---|---|---|---|---|
| Without detection of shorts across contacts |  |  |  |  |
| With detection of shorts across contacts |  |  |  |  |

Safety relays PNOZsigma PNOZ s4.1

Connection

- ▶ Supply voltage

| Supply voltage | Unit types with U_B 48 - 240 VAC/DC | Unit types with U_B 24 VDC |
|----------------|---------------------------------------|------------------------------|
| | | |

- ▶ Input circuit

| Input circuit | Single-channel | Dual-channel |
|---|----------------|--------------|
| E-Stop without detection of shorts across contacts | | |
| E-Stop with detection of shorts across contacts | | |
| Safety gate without detection of shorts across contacts | | |
| Safety gate with detection of shorts across contacts | | |
| Light beam device or safety switch with detection of shorts across contacts via ESPE (only when $U_B = 24$ VDC) | | |

Safety relays PNOZsigma PNOZ s4.1

▶ Start circuit/feedback loop

| Start circuit/feedback loop | Without feedback loop monitoring | With feedback loop monitoring |
|----------------------------------|----------------------------------|-------------------------------|
| Automatic start | | |
| Monitored, manual start/re-start | | |

▶ Semiconductor output

| Unit types with U_B 24 VDC | Unit types with U_B 48 - 240 VAC/DC |
|---|---------------------------------------|
| | |
| *Connect together the 0V connections on all the external power supplies | |

Legend

- ▶ S1/S2: E-STOP/safety gate switch
- ▶ S3: Reset button
- ▶ \uparrow : Switch operated
- ▶ : Gate open
- ▶ : Gate closed

Safety relays PNOZsigma PNOZ s4.1

Dimensions in mm

*with spring-loaded terminals

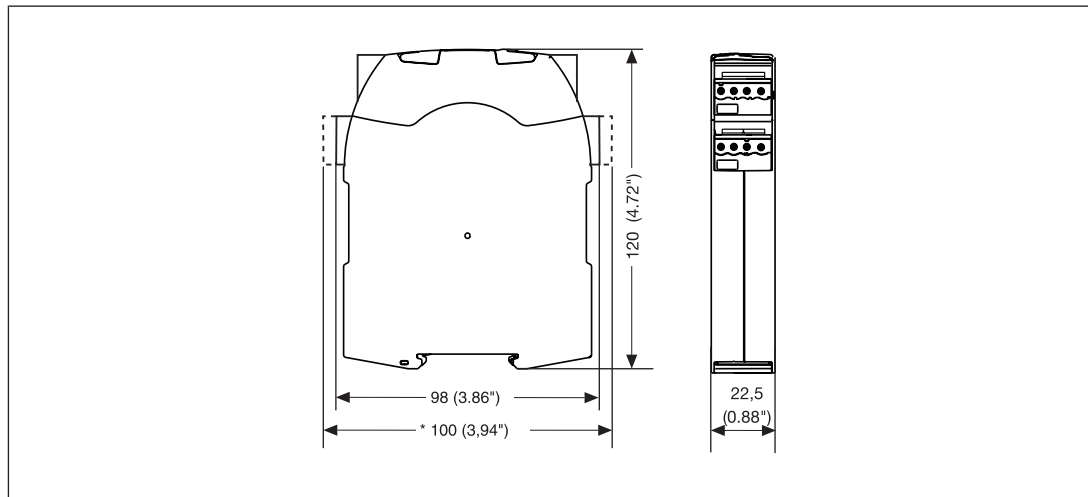

Technical details

| General | 750124 | 750154 | 751124 | 751154 |
|--------------------------------------|--|--|--|--|
| Approvals | CCC, CE, EAC (Eurasian), TÜV, cULus Listed | CCC, CE, EAC (Eurasian), TÜV, cULus Listed | CCC, CE, EAC (Eurasian), TÜV, cULus Listed | CCC, CE, EAC (Eurasian), TÜV, cULus Listed |
| Electrical data | 750124 | 750154 | 751124 | 751154 |
| Supply voltage | | | | |
| Voltage | 24 V | 48 - 240 V | 24 V | 48 - 240 V |
| Kind | DC | AC/DC | DC | AC/DC |
| Voltage tolerance | -15 %/+10 % | -15 %/+10 % | -15 %/+10 % | -15 %/+10 % |
| Output of external power supply (AC) | – | 5 VA | – | 5 VA |
| Output of external power supply (DC) | 2,5 W | 2,5 W | 2,5 W | 2,5 W |
| Frequency range AC | – | 50 - 60 Hz | – | 50 - 60 Hz |
| Residual ripple DC | 20 % | 160 % | 20 % | 160 % |
| Duty cycle | 100 % | 100 % | 100 % | 100 % |
| Inputs | 750124 | 750154 | 751124 | 751154 |
| Number | 2 | 2 | 2 | 2 |

Safety relays PNOZsigma PNOZ s4.1

| Inputs | 750124 | 750154 | 751124 | 751154 |
|-------------------------------|--------|--------|--------|--------|
| Voltage at | | | | |
| Input circuit DC | 24 V | 24 V | 24 V | 24 V |
| Start circuit DC | 24 V | 24 V | 24 V | 24 V |
| Feedback loop DC | 24 V | 24 V | 24 V | 24 V |
| Current at | | | | |
| Input circuit DC | 50 mA | 50 mA | 50 mA | 50 mA |
| Start circuit DC | 50 mA | 50 mA | 50 mA | 50 mA |
| Feedback loop DC | 50 mA | 50 mA | 50 mA | 50 mA |
| Max. inrush current impulse | | | | |
| Current pulse, input circuit | 0,2 A | 0,2 A | 0,2 A | 0,2 A |
| Pulse duration, input circuit | 100 ms | 100 ms | 100 ms | 100 ms |
| Current pulse, feedback loop | 0,2 A | 0,2 A | 0,2 A | 0,2 A |
| Pulse duration, feedback loop | 15 ms | 15 ms | 15 ms | 15 ms |
| Current pulse, start circuit | 0,2 A | 0,2 A | 0,2 A | 0,2 A |
| Pulse duration, start circuit | 15 ms | 15 ms | 15 ms | 15 ms |

Safety relays PNOZsigma PNOZ s4.1

| Inputs | 750124 | 750154 | 751124 | 751154 |
|---|---------------|---------------|---------------|---------------|
| Max. overall cable resistance R _{lmax} | | | | |
| Single-channel at UB DC | 30 Ohm | 30 Ohm | 30 Ohm | 30 Ohm |
| Single-channel at UB AC | – | 30 Ohm | – | 30 Ohm |
| Dual-channel without detection of shorts across contacts at UB DC | 60 Ohm | 60 Ohm | 60 Ohm | 60 Ohm |
| Dual-channel without detection of shorts across contacts at UB AC | – | 60 Ohm | – | 60 Ohm |
| Dual-channel with detection of shorts across contacts at UB DC | 30 Ohm | 30 Ohm | 30 Ohm | 30 Ohm |
| Dual-channel with detection of shorts across contacts at UB AC | – | 30 Ohm | – | 30 Ohm |
| Semiconductor outputs | 750124 | 750154 | 751124 | 751154 |
| Number | 1 | 1 | 1 | 1 |
| Voltage | 24 V | 24 V | 24 V | 24 V |
| Current | 20 mA | 20 mA | 20 mA | 20 mA |
| Relay outputs | 750124 | 750154 | 751124 | 751154 |
| Number of output contacts | | | | |
| Safety contacts (N/O), instantaneous | 3 | 3 | 3 | 3 |
| Auxiliary contacts (N/C) | 1 | 1 | 1 | 1 |
| Max. short circuit current I _K | 1 kA | 1 kA | 1 kA | 1 kA |
| Utilisation category | | | | |
| In accordance with the standard | EN 60947-4-1 | EN 60947-4-1 | EN 60947-4-1 | EN 60947-4-1 |

Safety relays PNOZsigma PNOZ s4.1

| Relay outputs | 750124 | 750154 | 751124 | 751154 |
|---|--------------|--------------|--------------|--------------|
| Utilisation category of safety contacts | | | | |
| AC1 at | 240 V | 240 V | 240 V | 240 V |
| Min. current | 0,01 A | 0,01 A | 0,01 A | 0,01 A |
| Max. current | 1,5 A | 1,5 A | 1,5 A | 1,5 A |
| Max. power | 375 VA | 375 VA | 375 VA | 375 VA |
| DC1 at | 24 V | 24 V | 24 V | 24 V |
| Min. current | 0,01 A | 0,01 A | 0,01 A | 0,01 A |
| Max. current | 6 A | 6 A | 6 A | 6 A |
| Max. power | 150 W | 150 W | 150 W | 150 W |
| Utilisation category of auxiliary contacts | | | | |
| AC1 at | 240 V | 240 V | 240 V | 240 V |
| Min. current | 0,01 A | 0,01 A | 0,01 A | 0,01 A |
| Max. current | 1,5 A | 1,5 A | 1,5 A | 1,5 A |
| Max. power | 375 VA | 375 VA | 375 VA | 375 VA |
| DC1 at | 24 V | 24 V | 24 V | 24 V |
| Min. current | 0,01 A | 0,01 A | 0,01 A | 0,01 A |
| Max. current | 6 A | 6 A | 6 A | 6 A |
| Max. power | 150 W | 150 W | 150 W | 150 W |
| Utilisation category In accordance with the standard | | | | |
| | EN 60947-5-1 | EN 60947-5-1 | EN 60947-5-1 | EN 60947-5-1 |
| Utilisation category of safety contacts | | | | |
| AC15 at | 230 V | 230 V | 230 V | 230 V |
| Max. current | 0,6 A | 0,6 A | 0,6 A | 0,6 A |
| DC13 (6 cycles/min) at | 24 V | 24 V | 24 V | 24 V |
| Max. current | 0,4 A | 0,4 A | 0,4 A | 0,4 A |
| Utilisation category of auxiliary contacts | | | | |
| AC15 at | 230 V | 230 V | 230 V | 230 V |
| Max. current | 0,6 A | 0,6 A | 0,6 A | 0,6 A |
| DC13 (6 cycles/min) at | 24 V | 24 V | 24 V | 24 V |
| Max. current | 0,4 A | 0,4 A | 0,4 A | 0,4 A |

Safety relays PNOZsigma PNOZ s4.1

| Relay outputs | 750124 | 750154 | 751124 | 751154 |
|--|--------------------------------------|--------------------------------------|--------------------------------------|--------------------------------------|
| Utilisation category in accordance with UL | | | | |
| Voltage | 240 V AC G.U. (same polarity) | 240 V AC G.U. (same polarity) | 240 V AC G.U. (same polarity) | 240 V AC G.U. (same polarity) |
| With current | 1,5 A | 1,5 A | 1,5 A | 1,5 A |
| Voltage | 24 V DC G. U. | 24 V DC G. U. | 24 V DC G. U. | 24 V DC G. U. |
| With current | 6 A | 6 A | 6 A | 6 A |
| External contact fuse protection, safety contacts | | | | |
| In accordance with the standard | EN 60947-5-1 | EN 60947-5-1 | EN 60947-5-1 | EN 60947-5-1 |
| Max. melting integral | 66 A²s | 66 A²s | 66 A²s | 66 A²s |
| Blow-out fuse, quick | 6 A | 6 A | 6 A | 6 A |
| Blow-out fuse, slow | 4 A | 4 A | 4 A | 4 A |
| Blow-out fuse, gG | 6 A | 6 A | 6 A | 6 A |
| Circuit breaker 24V AC/DC, characteristic B/C | 4 A | 4 A | 4 A | 4 A |
| External contact fuse protection, auxiliary contacts | | | | |
| Max. melting integral | 66 A²s | 66 A²s | 66 A²s | 66 A²s |
| Blow-out fuse, quick | 6 A | 6 A | 6 A | 6 A |
| Blow-out fuse, slow | 4 A | 4 A | 4 A | 4 A |
| Blow-out fuse, gG | 6 A | 6 A | 6 A | 6 A |
| Circuit breaker 24 V AC/DC, characteristic B/C | 4 A | 4 A | 4 A | 4 A |
| Contact material | AgCuNi + 0,2 µm Au | AgCuNi + 0,2 µm Au | AgCuNi + 0,2 µm Au | AgCuNi + 0,2 µm Au |

Safety relays PNOZsigma PNOZ s4.1

| Conventional thermal current while loading several contacts | 750124 | 750154 | 751124 | 751154 |
|---|--------|--------|--------|--------|
| Ith per contact at UB AC; AC1: 240 V, DC1: 2 4 V | | | | |
| Conv. therm. current with 1 contact | – | 6 A | – | 6 A |
| Conv. therm. current with 2 contacts | – | 6 A | – | 6 A |
| Conv. therm. current with 3 contacts | – | 4,5 A | – | 4,5 A |
| Ith per contact at UB DC; AC1: 240 V, DC1: 2 4 V | | | | |
| Conv. therm. current with 1 contact | 6 A | 6 A | 6 A | 6 A |
| Conv. therm. current with 2 contacts | 6 A | 6 A | 6 A | 6 A |
| Conv. therm. current with 3 contacts | 4,5 A | 4,5 A | 4,5 A | 4,5 A |

Safety relays PNOZsigma PNOZ s4.1

| Times | 750124 | 750154 | 751124 | 751154 |
|---|--------|--------|--------|--------|
| Switch-on delay | | | | |
| With automatic start typ. | 170 ms | 170 ms | 170 ms | 170 ms |
| With automatic start max. | 300 ms | 300 ms | 300 ms | 300 ms |
| With automatic start after power on typ. | 350 ms | 350 ms | 350 ms | 350 ms |
| With automatic start after power on max. | 600 ms | 600 ms | 600 ms | 600 ms |
| With manual start typ. | 40 ms | 40 ms | 40 ms | 40 ms |
| With manual start max. | 300 ms | 300 ms | 300 ms | 300 ms |
| With monitored start with rising edge typ. | 35 ms | 35 ms | 35 ms | 35 ms |
| With monitored start with rising edge max. | 50 ms | 50 ms | 50 ms | 50 ms |
| With monitored start with falling edge typ. | 55 ms | 55 ms | 55 ms | 55 ms |
| With monitored start with falling edge max. | 70 ms | 70 ms | 70 ms | 70 ms |
| Delay-on de-energisation | | | | |
| With E-STOP typ. | 10 ms | 10 ms | 10 ms | 10 ms |
| With E-STOP max. | 20 ms | 20 ms | 20 ms | 20 ms |
| With power failure typ. | 40 ms | 40 ms | 40 ms | 40 ms |
| With power failure max. | 80 ms | 80 ms | 80 ms | 80 ms |
| Recovery time at max. switching frequency 1/s | | | | |
| After E-STOP | 50 ms | 50 ms | 50 ms | 50 ms |
| After power failure | 100 ms | 100 ms | 100 ms | 100 ms |
| Waiting period with a monitored start | | | | |
| With rising edge | 120 ms | 120 ms | 120 ms | 120 ms |
| With falling edge | 250 ms | 150 ms | 250 ms | 150 ms |

Safety relays PNOZsigma PNOZ s4.1

| Times | 750124 | 750154 | 751124 | 751154 |
|--|---|---|---|---|
| Min. start pulse duration with a monitored start | | | | |
| With rising edge | 30 ms | 30 ms | 30 ms | 30 ms |
| With falling edge | 100 ms | 100 ms | 100 ms | 100 ms |
| Supply interruption before de-energisation | 20 ms | 20 ms | 20 ms | 20 ms |
| Simultaneity, channel 1 and 2 max. | ∞ | ∞ | ∞ | ∞ |
| Environmental data | 750124 | 750154 | 751124 | 751154 |
| Climatic suitability | EN 60068-2-78 | EN 60068-2-78 | EN 60068-2-78 | EN 60068-2-78 |
| Ambient temperature | | | | |
| Temperature range | -10 - 60 °C | -10 - 60 °C | -10 - 60 °C | -10 - 60 °C |
| Storage temperature | | | | |
| Temperature range | -40 - 85 °C | -40 - 85 °C | -40 - 85 °C | -40 - 85 °C |
| Climatic suitability | | | | |
| Humidity | 93 % r. h. at 40 °C | 93 % r. h. at 40 °C | 93 % r. h. at 40 °C | 93 % r. h. at 40 °C |
| Condensation during operation | Not permitted | Not permitted | Not permitted | Not permitted |
| EMC | EN 60947-5-1, EN 61000-6-2, EN 61000-6-4, EN 61326-3-1 | EN 60947-5-1, EN 61000-6-2, EN 61000-6-4, EN 61326-3-1 | EN 60947-5-1, EN 61000-6-2, EN 61000-6-4, EN 61326-3-1 | EN 60947-5-1, EN 61000-6-2, EN 61000-6-4, EN 61326-3-1 |
| Vibration | | | | |
| In accordance with the standard | EN 60068-2-6 | EN 60068-2-6 | EN 60068-2-6 | EN 60068-2-6 |
| Frequency | 10 - 150 Hz | 10 - 150 Hz | 10 - 150 Hz | 10 - 150 Hz |
| Amplitude | 0,35 mm | 0,35 mm | 0,35 mm | 0,35 mm |
| Airgap creepage | | | | |
| In accordance with the standard | EN 60947-1 | EN 60947-1 | EN 60947-1 | EN 60947-1 |
| Overvoltage category | III / II | III / II | III / II | III / II |
| Pollution degree | 2 | 2 | 2 | 2 |
| Rated insulation voltage | 250 V | 250 V | 250 V | 250 V |
| Rated impulse withstand voltage | 4 kV | 4 kV | 4 kV | 4 kV |

Safety relays PNOZsigma PNOZ s4.1

| Environmental data | 750124 | 750154 | 751124 | 751154 |
|---|--|--|---|---|
| Protection type | | | | |
| Mounting area (e.g. control cabinet) | IP54 | IP54 | IP54 | IP54 |
| Housing | IP40 | IP40 | IP40 | IP40 |
| Terminals | IP20 | IP20 | IP20 | IP20 |
| Mechanical data | 750124 | 750154 | 751124 | 751154 |
| Mounting position | Any | Any | Any | Any |
| Mechanical life | 10,000,000 cycles | 10,000,000 cycles | 10,000,000 cycles | 10,000,000 cycles |
| Material | | | | |
| Bottom | PC | PC | PC | PC |
| Front | PC | PC | PC | PC |
| Top | PC | PC | PC | PC |
| Connection type | Screw terminal | Screw terminal | Spring-loaded terminal | Spring-loaded terminal |
| Mounting type | plug-in | plug-in | plug-in | plug-in |
| Conductor cross section with screw terminals | | | | |
| 1 core flexible | 0,25 - 2,5 mm ² , 24 - 12 AWG | 0,25 - 2,5 mm ² , 24 - 12 AWG | – | – |
| 2 core with the same cross section, flexible with crimp connectors, no plastic sleeve | 0,25 - 1 mm ² , 24 - 16 AWG | 0,25 - 1 mm ² , 24 - 16 AWG | – | – |
| 2 core with the same cross section, flexible without crimp connectors or with TWIN crimp connectors | 0,2 - 1,5 mm ² , 24 - 16 AWG | 0,2 - 1,5 mm ² , 24 - 16 AWG | – | – |
| Torque setting with screw terminals | 0,5 Nm | 0,5 Nm | – | – |
| Conductor cross section with spring-loaded terminals: | | | | |
| Flexible with/without crimp connector | – | – | 0,2 - 2,5 mm ² , 24 - 12 AWG | 0,2 - 2,5 mm ² , 24 - 12 AWG |
| Spring-loaded terminals: Terminal points per connection | – | – | 2 | 2 |

Safety relays PNOZsigma PNOZ s4.1

| Mechanical data | 750124 | 750154 | 751124 | 751154 |
|---|---------|---------|---------|---------|
| Stripping length with spring-loaded terminals | – | – | 9 mm | 9 mm |
| Dimensions | | | | |
| Height | 98 mm | 98 mm | 100 mm | 100 mm |
| Width | 22,5 mm | 22,5 mm | 22,5 mm | 22,5 mm |
| Depth | 120 mm | 120 mm | 120 mm | 120 mm |
| Weight | 190 g | 210 g | 190 g | 210 g |

Where standards are undated, the 2014-07 latest editions shall apply.

Safety characteristic data

| Operating Mode | EN ISO 13849-1: 2015 | EN ISO 13849-1: 2015 | EN 62061 SIL CL | EN 62061 PFH _D [1/h] | IEC 61511 SIL | IEC 61511 PFD | EN ISO 13849-1: 2015 T _M [year] |
|--------------------------------|----------------------|----------------------|-----------------|---------------------------------|---------------|---------------|--|
| | PL | Category | | | | | |
| Safety contacts, instantaneous | PL e | Cat. 4 | SIL CL 3 | 2,31E-09 | SIL 3 | 2,03E-06 | 20 |

All the units used within a safety function must be considered when calculating the safety characteristic data.

Supplementary data

The PFH value depends on the switching frequency and the load on the relay output. If the service life graphs are not accessible, the stated PFH value can be used irrespective of the switching frequency and the load, as the PFH value already considers the relay's B10d value as well as the failure rates of the other components.

Safety relays PNOZsigma PNOZ s4.1

Service life graph

The service life graphs indicate the number of cycles from which failures due to wear must be expected. The wear is mainly caused by the electrical load; the mechanical load is negligible.

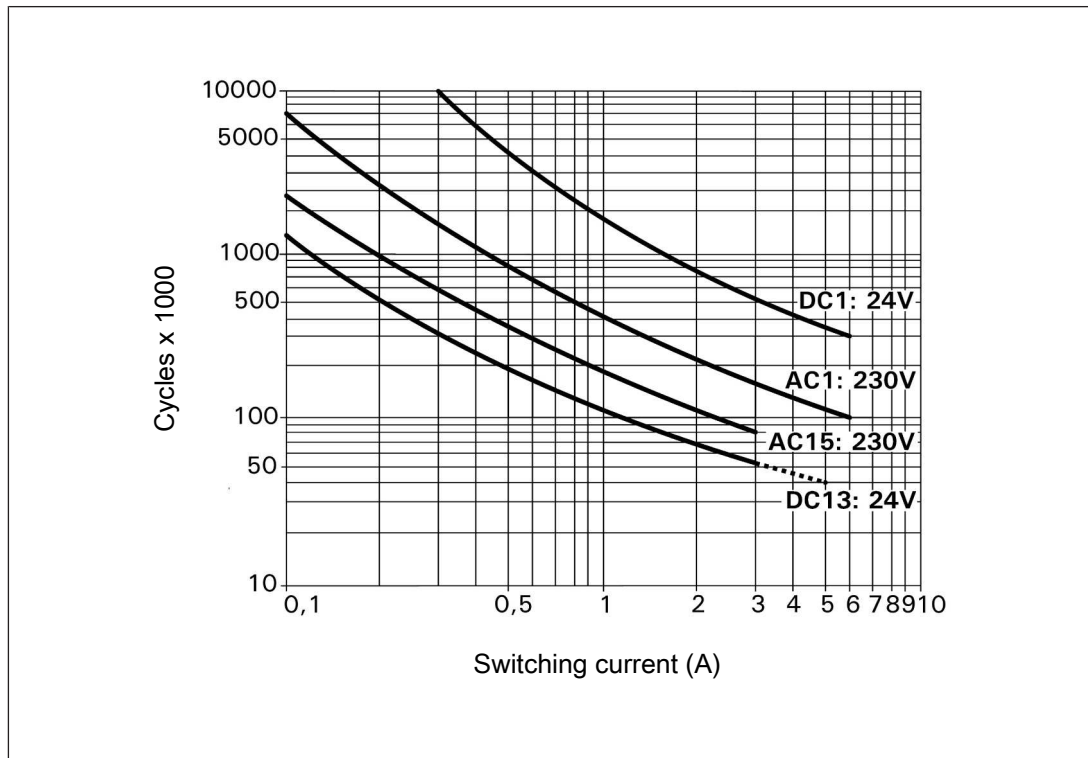

Fig.: Service life graphs at 24 V DC and 230 V AC

Safety relays PNOZsigma PNOZ s4.1

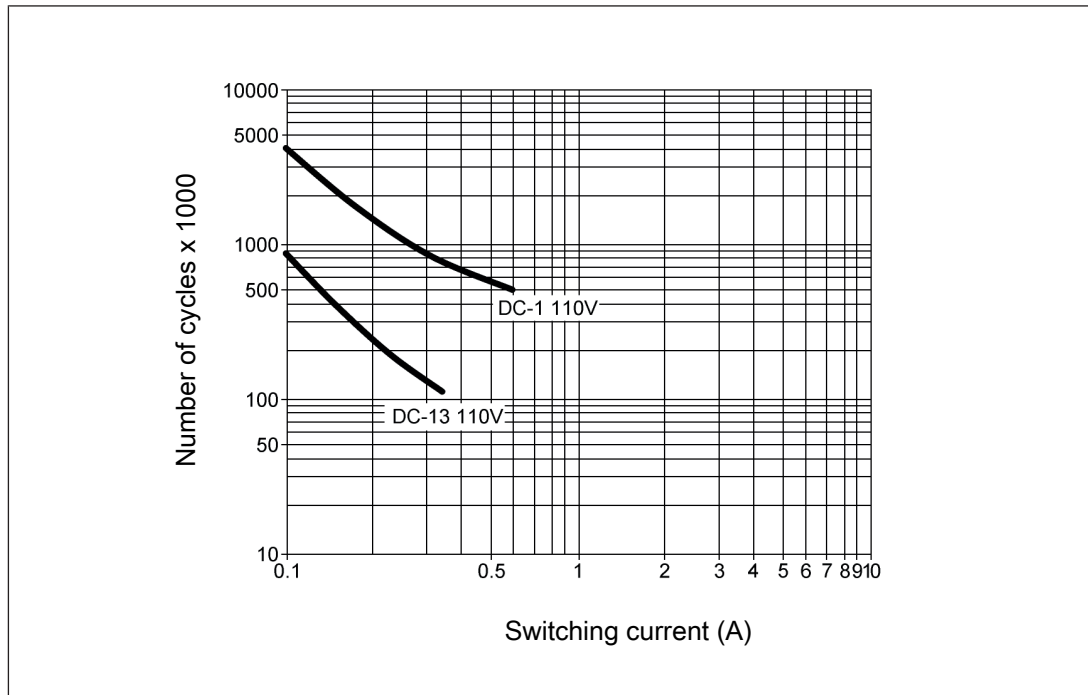

Fig.: Service life graphs at 110 V DC

Example

- ▶ Inductive load: 0.2 A
- ▶ Utilisation category: AC15
- ▶ Contact service life: 1 000 000 cycles

Provided the application to be implemented requires fewer than 1 000 000 cycles, the PFH value (see [Technical details \[622\]](#)) can be used in the calculation.

To increase the service life, sufficient spark suppression must be provided on all relay contacts. With capacitive loads, any power surges that occur must be noted. With DC contactors, use flywheel diodes for spark suppression.

Order reference

| Product type | Features | Connection type | Order no. |
|--------------|------------------|-------------------------|-----------|
| PNOZ s4.1 | 24 VDC | Screw terminals | 750 124 |
| PNOZ s4.1 C | 24 VDC | Spring-loaded terminal | 751 124 |
| PNOZ s4.1 | 48 - 240 V AC/DC | Screw terminals | 750 154 |
| PNOZ s4.1 C | 48 - 240 V AC/DC | Spring-loaded terminals | 751 154 |

Safety relays PNOZsigma PNOZ s5



Unit features

- ▶ Positive-guided relay outputs:
 - 2 safety contacts (N/O), instantaneous
 - 2 safety contacts (N/O), delay-on de-energisation
- ▶ 1 semiconductor output
- ▶ Connection options for:
 - E-STOP pushbuttons
 - Safety gate limit switches
 - Start buttons
 - Light grids and safety switches with detection of shorts across contacts
- ▶ A connector can be used to connect 1 PNOZsigma contact expansion module
- ▶ Operating modes and delay times can be selected via rotary switches
- ▶ LED indicator for:
 - Supply voltage
 - Input status, channel 1
 - Input status, channel 2
 - Switch status channel 1/2
 - Start circuit
 - Error
- ▶ Plug-in connection terminals (either spring-loaded terminal or screw terminal)
- ▶ See order reference for unit types

Safety relays PNOZsigma PNOZ s5

Block diagram/terminal configuration

Type: 24 VDC

- ▶ U_B : 24 VDC; Order No. 750105, 751105, 751185

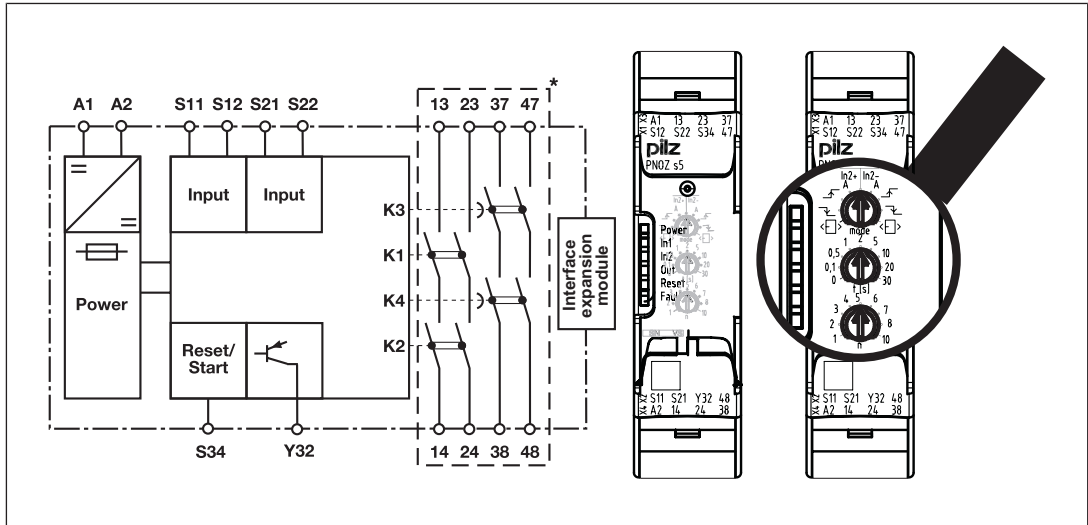

Fig.: Centre: Front view with cover, right: Front view without cover

*Insulation between the non-marked area and the relay contacts: Basic insulation (over-voltage category III), Protective separation (overvoltage category II)

Type: 48 - 240 VAC/DC

- ▶ U_B : 48 – 240 VAC/DC; Order No. 750135, 751135

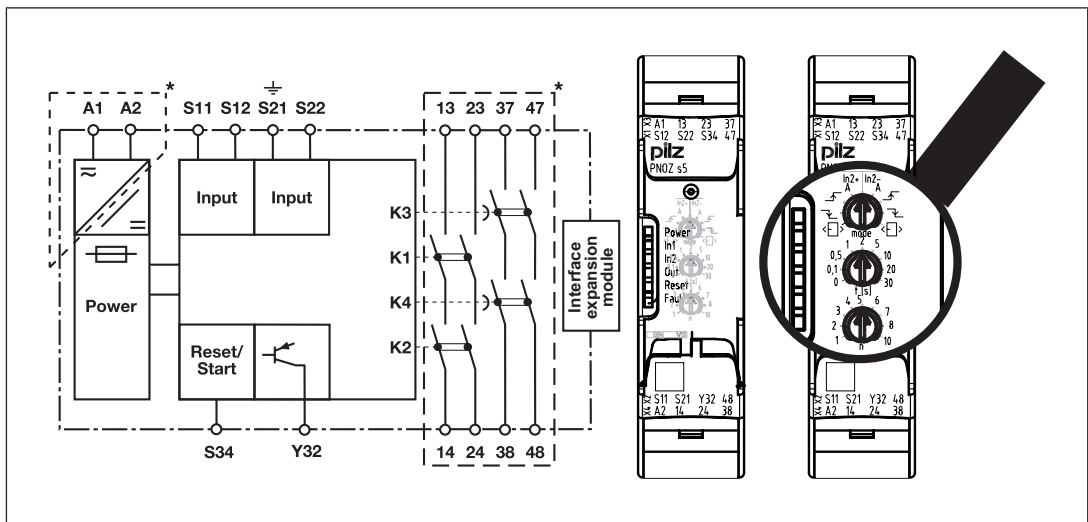

Fig.: Centre: Front view with cover, right: Front view without cover

*Insulation between the non-marked area and the relay contacts: Basic insulation (over-voltage category III), Protective separation (overvoltage category II)

Safety relays PNOZsigma PNOZ s5

Function description

- ▶ $\overline{\text{In2}}$ Single-channel operation: no redundancy in the input circuit, earth faults in the start circuit and input circuit are detected.
- ▶ Dual-channel operation without detection of shorts across contacts: Redundant input circuit, detects PNOZ s5
 - earth faults in the start and input circuit,
 - short circuits in the input circuit and, with a monitored start, in the start circuit too.
- ▶ $\overline{\text{In2}}$ Dual-channel operation with detection of shorts across contacts: Redundant input circuit, detects PNOZ s5
 - earth faults in the start and input circuit,
 - Short circuits in the input circuit and, with a monitored start, in the start circuit too,
 - Shorts across contacts in the input circuit.
- ▶ **A** Automatic start: Unit is active once the input circuit has been closed.
- ▶ Manual start Unit is active once the input circuit and the start circuit are closed.
- ▶ $\overline{\downarrow}$ Monitored start with falling edge: Unit is active once
 - the input circuit is closed and then the start circuit is closed and opened again.
 - the start circuit is closed and then opened again once the input circuit is closed.
- ▶ \uparrow Monitored start with rising edge: Unit is active once the input circuit is closed and once the start circuit is closed after the waiting period has elapsed (see technical details).
- ▶ \square Start with start-up test: The unit checks whether safety gates that are closed are opened and then closed again when supply voltage is applied.
- ▶ Ability to increase the number of contacts available on the
 - instantaneous safety contacts by using connectors to link to a PNOZsigma contact expansion module
 - delayed/instantaneous safety contacts by connecting contact expansion modules or external contactors

Safety relays PNOZsigma PNOZ s5

Timing diagrams

Automatic and manual start

- ▶ [1]: Automatic start
- ▶ [2]: Manual start
 - a: Input circuit closes before start circuit
 - b: Start circuit closes before input circuit

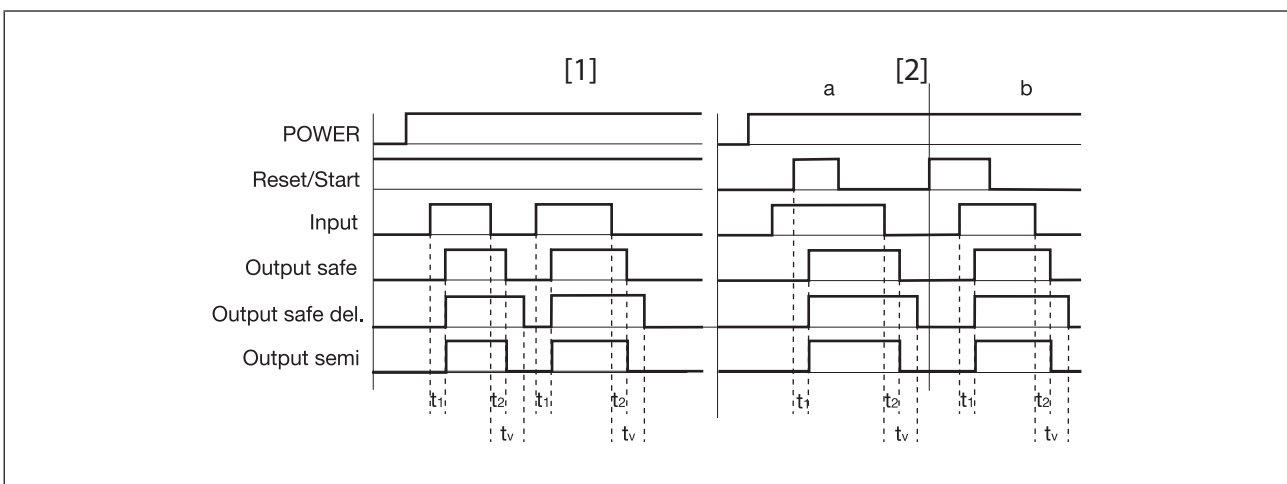

Legend

- ▶ POWER: Supply voltage
- ▶ Start: Start circuit
- ▶ Input: Input circuits
- ▶ Output safe: Safety contacts, instantaneous
- ▶ Output safe del: Safety contacts, delayed
- ▶ Output semi: Semiconductor output
- ▶ t_1 : Switch-on delay
- ▶ t_2 : Delay-on de-energisation
- ▶ t_v : Delay time

Safety relays PNOZsigma PNOZ s5

Monitored start

- ▶ [1]: Monitored start with rising edge
 - a: Input circuit closes before start circuit
 - b: Start circuit closes before input circuit
- ▶ [2]: Monitored start with falling edge
 - a: Input circuit closes before start circuit
 - b: Start circuit closes before input circuit

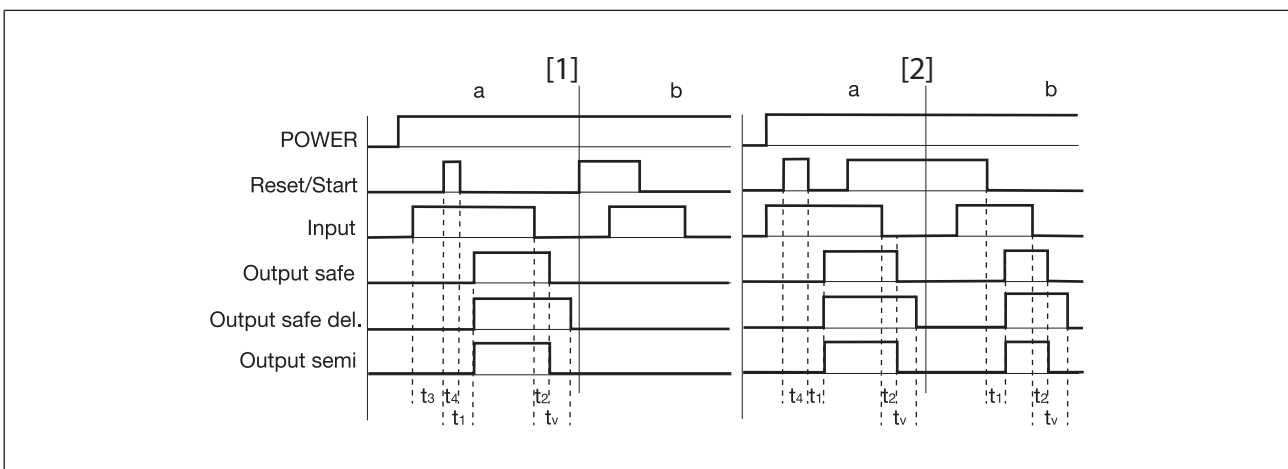

Legend

- ▶ POWER: Supply voltage
- ▶ Start: Start circuit
- ▶ Input: Input circuits
- ▶ Output safe: Safety contacts, instantaneous
- ▶ Output safe del.: Safety contacts, delayed
- ▶ Output semi: Semiconductor output
- ▶ t_1 : Switch-on delay
- ▶ t_2 : Delay-on de-energisation
- ▶ t_3 : Waiting period with a monitored start
- ▶ t_4 : Min. start pulse duration with a monitored start
- ▶ t_v : Delay time

Safety relays PNOZsigma PNOZ s5

Reset with start-up test

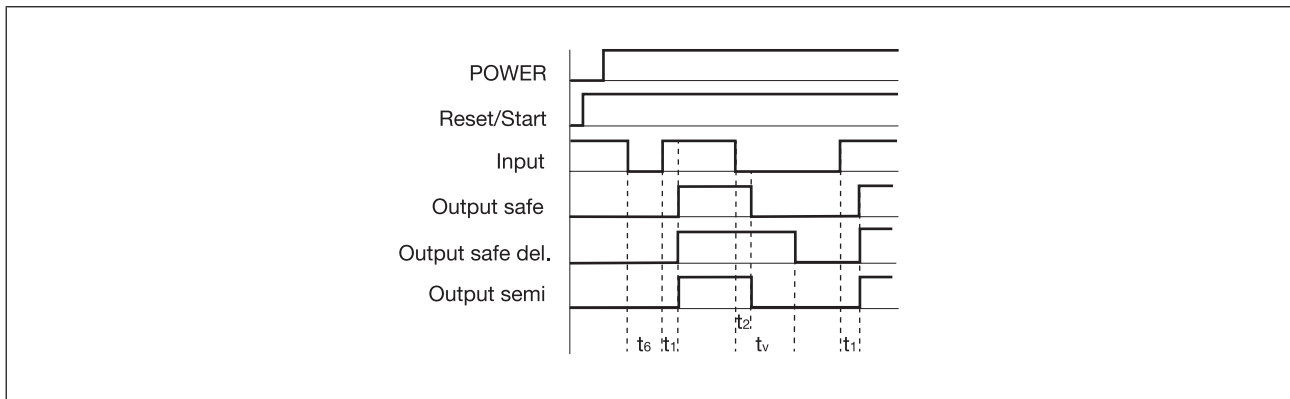

Legend

- ▶ POWER: Supply voltage
- ▶ Start: Start circuit
- ▶ Input: Input circuits
- ▶ Output safe: Safety contacts, instantaneous
- ▶ Output safe del: Safety contacts, delayed
- ▶ Output semi: Semiconductor output
- ▶ t_1 : Switch-on delay
- ▶ t_2 : Delay-on de-energisation
- ▶ t_v : Delay time
- ▶ t_6 : Recovery time

Installation

Install base unit without contact expansion module:

- ▶ Ensure that the plug terminator is inserted at the side of the unit.

Connect base unit and PNOZsigma contact expansion module:

- ▶ Remove the plug terminator at the side of the base unit and at the contact expansion module.
- ▶ Connect the base unit and the contact expansion module to the supplied connector before mounting the units to the DIN rail.

Installation in control cabinet

- ▶ The safety relay should be installed in a control cabinet with a protection type of at least IP54.
- ▶ Use the notch on the rear of the unit to attach it to a DIN rail (35 mm).
- ▶ When installed vertically: Secure the unit by using a fixing element (e.g. retaining bracket or end angle).
- ▶ Push the device upwards or downwards before lifting it from the DIN rail.

Safety relays PNOZsigma PNOZ s5

Wiring

Please note:

- ▶ Information given in the "[Technical details \[644\]](#)" must be followed.
- ▶ Outputs 13-14, 23-24 are instantaneous safety contacts; outputs 37-38, 47-48 are delay-on de-energisation safety contacts, semiconductor output Y32 is an auxiliary output (e.g. for display).
- ▶ Semiconductor output Y32 should **not** be used for safety circuits!
- ▶ To prevent contact welding, a fuse should be connected before the output contacts (see [Technical details \[644\]](#)).
- ▶ Calculation of the max. cable length l_{\max} in the input circuit:

$$l_{\max} = \frac{R_{l_{\max}}}{R_l / \text{km}}$$

$R_{l_{\max}}$ = max. overall cable resistance (see [Technical details \[644\]](#))

R_l / km = cable resistance/km

- ▶ Use copper wire that can withstand 60/75 °C.
- ▶ Sufficient fuse protection must be provided on all output contacts with capacitive and inductive loads.
- ▶ With U_B 48 – 240 VAC/DC: Connect S21 to the functional earth.
- ▶ When connecting magnetically operated, reed proximity switches, ensure that the max. peak inrush current (on the input circuit) does not overload the proximity switch.
- ▶ Ensure the wiring and EMC requirements of IEC 60204-1 are met.
- ▶ On 24 VDC devices:
The power supply must comply with the regulations for extra low voltages with protective electrical separation (SELV, PELV) in accordance with VDE 0100, Part 410.

Important for detection of shorts across contacts:

As this function for detecting shorts across contacts is not failsafe, it is tested by Pilz during the final control check. If there is a danger of exceeding the cable runs, we recommend the following test after the installation of the device:

1. Unit ready for operation (output contacts closed)
2. Short circuit the test terminals S12, S22 for detecting shorts across the inputs.
3. The unit's fuse must be triggered and the output contacts must open. Cable lengths in the scale of the maximum length can delay the fuse triggering for up to 2 minutes.
4. Reset the fuse: remove the short circuit and switch off the supply voltage for approx. 1 minute.

Safety relays PNOZsigma PNOZ s5









Preparing for operation

Operating modes and delay time

The operating mode and delay time are set via the rotary switches on the unit. You can do this by opening the cover on the front of the unit.

Set operating modes

- ▶ Switch off supply voltage.
- ▶ Select operating mode via the operating mode selector switch "mode".
- ▶ If the operating mode selector switch "mode" is in its start position (vertical position), an error message will appear.

| Operating mode selector switch "mode" | Automatic or manual start | Monitored start rising edge | Monitored start falling edge | Automatic start with start-up test |
|---|---|---|---|---|
| Without detection of shorts across contacts |  |  |  |  |
| With detection of shorts across contacts |  |  |  |  |

Set delay time

Time selector switch "t[s]"

Factor selector switch "n"

$n \times t[s] = \text{Delay time}$

Example:

$t = 4 \text{ s}, n = 5$

Delay time = $5 \times 4 = 20 \text{ s}$

The min. delay time that can be set is (when $t = 0$): 0.04 s.

Safety relays PNOZsigma PNOZ s5

Connection

| Supply voltage | Unit types with UB 24 VDC | Unit types with UB 48 – 240 VAC/DC |
|---|---------------------------|------------------------------------|
| | | |
| Input circuit | Single-channel | Dual-channel |
| E-Stop without detection of shorts across contacts | | |
| E-Stop with detection of shorts across contacts | | |
| Safety gate without detection of shorts across contacts | | |
| Safety gate with detection of shorts across contacts | | |

Safety relays PNOZsigma PNOZ s5

| Input circuit | Single-channel | Dual-channel |
|---|---|---------------------------------------|
| Light beam device or safety switch, detection of shorts across contacts via ESPE (only on unit types with $U_B = 24$ VDC) | | |
| Start circuit/feedback loop | Without feedback loop monitoring | With feedback loop monitoring |
| Automatic start | | |
| Monitored, manual start/restart | | |
| Semiconductor output | Unit types with U_B 24 VDC | Unit types with U_B 48 – 240 VAC/DC |
| | | |
| | *Connect together the 0V connections on all the external power supplies | |

Legend

- ▶ S1/S2: E-STOP/safety gate switch
- ▶ S3: Reset button
- ▶ ↑↑: Switch operated
- ▶ : Gate open

Safety relays PNOZsigma PNOZ s5

▶  Gate closed

Dimensions in mm

*with spring-loaded terminals

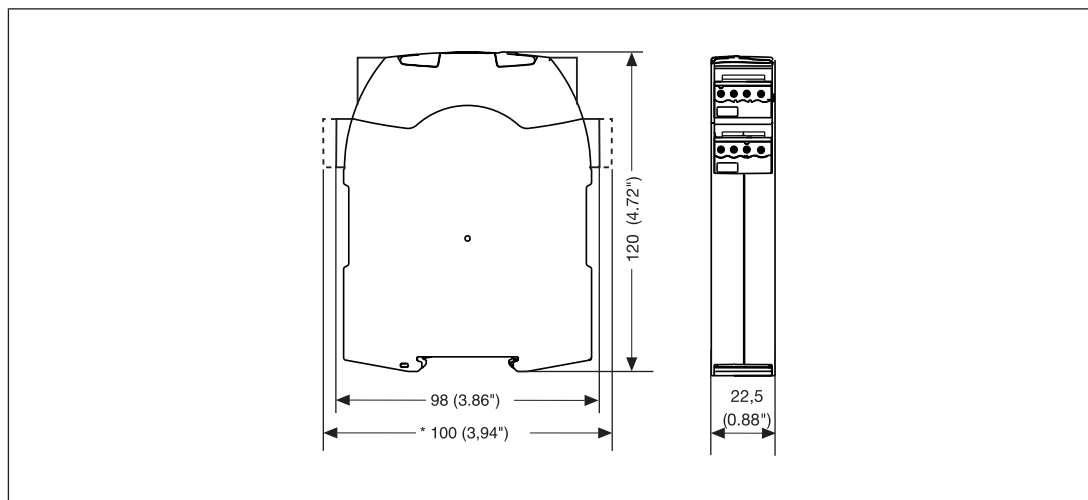

Technical details

Order no. 750105 – 751185

See below for more order numbers

| General | 750105 | 751105 | 751185 |
|--------------------------------------|---|---|---|
| Approvals | CCC, CE, EAC (Eurasian), KOSHA, TÜV, cULus Listed | CCC, CE, EAC (Eurasian), KOSHA, TÜV, cULus Listed | CCC, CE, EAC (Eurasian), KOSHA, TÜV, cULus Listed |
| Electrical data | 750105 | 751105 | 751185 |
| Supply voltage | | | |
| Voltage | 24 V | 24 V | 24 V |
| Kind | DC | DC | DC |
| Voltage tolerance | -15 %/+10 % | -15 %/+10 % | -15 %/+10 % |
| Output of external power supply (DC) | 4 W | 4 W | 4 W |
| Residual ripple DC | 20 % | 20 % | 20 % |
| Duty cycle | 100 % | 100 % | 100 % |
| Inputs | 750105 | 751105 | 751185 |
| Number | 2 | 2 | 2 |

Safety relays PNOZsigma PNOZ s5

| Inputs | 750105 | 751105 | 751185 |
|---|----------------|----------------|----------------|
| Voltage at | | | |
| Input circuit DC | 24 V | 24 V | 24 V |
| Start circuit DC | 24 V | 24 V | 24 V |
| Feedback loop DC | 24 V | 24 V | 24 V |
| Current at | | | |
| Input circuit DC | 40 mA | 40 mA | 40 mA |
| Start circuit DC | 40 mA | 40 mA | 40 mA |
| Feedback loop DC | 40 mA | 40 mA | 40 mA |
| Max. inrush current impulse | | | |
| Current pulse, input circuit | 0,2 A | 0,2 A | 0,2 A |
| Pulse duration, input circuit | 100 ms | 100 ms | 100 ms |
| Current pulse, feedback loop | 0,2 A | 0,2 A | 0,2 A |
| Pulse duration, feedback loop | 60 ms | 60 ms | 60 ms |
| Current pulse, start circuit | 0,2 A | 0,2 A | 0,2 A |
| Pulse duration, start circuit | 60 ms | 60 ms | 60 ms |
| Min. input resistance at power-on | | | |
| | 110 Ohm | 110 Ohm | 110 Ohm |
| Max. overall cable resistance R _{lmax} | | | |
| Single-channel at UB DC | 30 Ohm | 30 Ohm | 30 Ohm |
| Dual-channel without detection of shorts across contacts at UB DC | 30 Ohm | 30 Ohm | 30 Ohm |
| Dual-channel with detection of shorts across contacts at UB DC | 30 Ohm | 30 Ohm | 30 Ohm |
| Semiconductor outputs | | | |
| | 750105 | 751105 | 751185 |
| Number | 1 | 1 | 1 |
| Voltage | 24 V | 24 V | 24 V |
| Current | 20 mA | 20 mA | 20 mA |

Safety relays PNOZsigma PNOZ s5

| Relay outputs | 750105 | 751105 | 751185 |
|---|--------------|--------------|--------------|
| Number of output contacts | | | |
| Safety contacts (N/O), instantaneous | 2 | 2 | 2 |
| Safety contacts (N/O), delayed | 2 | 2 | 2 |
| Max. short circuit current IK | 1 kA | 1 kA | 1 kA |
| Utilisation category | | | |
| In accordance with the standard | EN 60947-4-1 | EN 60947-4-1 | EN 60947-4-1 |
| Utilisation category of safety contacts | | | |
| AC1 at | 240 V | 240 V | 240 V |
| Min. current | 0,01 A | 0,01 A | 0,01 A |
| Max. current | 6 A | 6 A | 6 A |
| Max. power | 1500 VA | 1500 VA | 1500 VA |
| DC1 at | 24 V | 24 V | 24 V |
| Min. current | 0,01 A | 0,01 A | 0,01 A |
| Max. current | 6 A | 6 A | 6 A |
| Max. power | 150 W | 150 W | 150 W |
| Utilisation category of safety contacts delayed | | | |
| AC1 at | 240 V | 240 V | 240 V |
| Min. current | 0,01 A | 0,01 A | 0,01 A |
| Max. current | 6 A | 6 A | 6 A |
| Max. power | 1500 VA | 1500 VA | 1500 VA |
| DC1 at | 24 V | 24 V | 24 V |
| Min. current | 0,01 A | 0,01 A | 0,01 A |
| Max. current | 6 A | 6 A | 6 A |
| Max. power | 150 W | 150 W | 150 W |
| Utilisation category | | | |
| In accordance with the standard | EN 60947-5-1 | EN 60947-5-1 | EN 60947-5-1 |
| Utilisation category of safety contacts | | | |
| AC15 at | 230 V | 230 V | 230 V |
| Max. current | 3 A | 3 A | 3 A |
| DC13 (6 cycles/min) at | 24 V | 24 V | 24 V |
| Max. current | 4 A | 4 A | 4 A |

Safety relays PNOZsigma PNOZ s5

| Relay outputs | 750105 | 751105 | 751185 |
|---|--------------------------------------|--------------------------------------|--------------------------------------|
| Utilisation category of safety contacts delayed | | | |
| AC15 at | 230 V | 230 V | 230 V |
| Max. current | 3 A | 3 A | 3 A |
| DC13 (6 cycles/min) at | 24 V | 24 V | 24 V |
| Max. current | 4 A | 4 A | 4 A |
| Utilisation category in accordance with UL | | | |
| Voltage | 240 V AC G.U. (same polarity) | 240 V AC G.U. (same polarity) | 240 V AC G.U. (same polarity) |
| With current | 6 A | 6 A | 6 A |
| Voltage | 24 V DC G. U. | 24 V DC G. U. | 24 V DC G. U. |
| With current | 6 A | 6 A | 6 A |
| Pilot Duty | B300, R300 | B300, R300 | B300, R300 |
| External contact fuse protection, safety contacts | | | |
| In accordance with the standard | EN 60947-5-1 | EN 60947-5-1 | EN 60947-5-1 |
| Max. melting integral | 66 A²s | 66 A²s | 66 A²s |
| Blow-out fuse, quick | 6 A | 6 A | 6 A |
| Blow-out fuse, slow | 4 A | 4 A | 4 A |
| Blow-out fuse, gG | 6 A | 6 A | 6 A |
| Circuit breaker 24V AC/DC, characteristic B/C | 4 A | 4 A | 4 A |
| External contact fuse protection, delayed safety contacts | | | |
| Max. melting integral | 66 A²s | 66 A²s | 66 A²s |
| Blow-out fuse, quick | 6 A | 6 A | 6 A |
| Blow-out fuse, slow | 4 A | 4 A | 4 A |
| Blow-out fuse, gG | 6 A | 6 A | 6 A |
| Circuit breaker 24 V AC/DC, characteristic B/C | 4 A | 4 A | 4 A |
| Contact material | AgCuNi + 0,2 µm Au | AgCuNi + 0,2 µm Au | AgCuNi + 0,2 µm Au |

Safety relays PNOZsigma PNOZ s5

| Conventional thermal current while loading several contacts | 750105 | 751105 | 751185 |
|--|------------|------------|------------|
| I _{th} per contact at UB DC; AC1: 240 V, DC1: 24 V | | | |
| Conv. therm. current with 1 contact | 6 A | 6 A | 6 A |
| Conv. therm. current with 2 contacts | 6 A | 6 A | 6 A |
| Conv. therm. current with 3 contacts | 6 A | 6 A | 6 A |
| Conv. therm. current with 4 contacts | 6 A | 6 A | 6 A |
| Times | 750105 | 751105 | 751185 |
| Switch-on delay | | | |
| With automatic start typ. | 180 ms | 180 ms | 180 ms |
| With automatic start max. | 330 ms | 330 ms | 330 ms |
| With automatic start after power on typ. | 1.430 ms | 1.430 ms | 1.430 ms |
| With automatic start after power on max. | 1.900 ms | 1.900 ms | 1.900 ms |
| With automatic start after power on typ. | – | – | – |
| With automatic start after power on max. | – | – | – |
| With manual start typ. | 45 ms | 45 ms | 45 ms |
| With manual start max. | 85 ms | 85 ms | 85 ms |
| With monitored start with rising edge typ. | 45 ms | 45 ms | 45 ms |
| With monitored start with rising edge max. | 70 ms | 70 ms | 70 ms |
| With monitored start with falling edge typ. | 60 ms | 60 ms | 60 ms |
| With monitored start with falling edge max. | 80 ms | 80 ms | 80 ms |
| Delay-on de-energisation | | | |
| With E-STOP typ. | 15 ms | 15 ms | 15 ms |
| With E-STOP max. | 20 ms | 20 ms | 20 ms |
| With power failure typ. | 75 ms | 75 ms | 75 ms |
| With power failure max. | 110 ms | 110 ms | 110 ms |
| Recovery time at max. switching frequency 1/s | | | |
| After E-STOP | 150 ms +tv | 150 ms +tv | 150 ms +tv |
| After power failure | 200 ms | 200 ms | 200 ms |

Safety relays PNOZsigma PNOZ s5

| Times | 750105 | 751105 | 751185 |
|--|---|---|---|
| Delay time t_v | 0,04 s, 0,1 s, 0,2 s, 0,3 s, 0,4 s, 0,5 s, 0,6 s, 0,7 s, 0,8 s, 1 s, 1,5 s, 2 s, 2,5 s, 3 s, 3,5 s, 4 s, 5 s, 6 s, 7 s, 8 s, 10 s, 12 s, 14 s, 15 s, 16 s, 20 s, 25 s, 30 s, 35 s, 40 s, 50 s, 60 s, 70 s, 80 s, 90 s, 100 s, 120 s, 140 s, 150 s, 160 s, 180 s, 200 s, 210 s, 240 s, 300 s | 0,04 s, 0,1 s, 0,2 s, 0,3 s, 0,4 s, 0,5 s, 0,6 s, 0,7 s, 0,8 s, 1 s, 1,5 s, 2 s, 2,5 s, 3 s, 3,5 s, 4 s, 5 s, 6 s, 7 s, 8 s, 10 s, 12 s, 14 s, 15 s, 16 s, 20 s, 25 s, 30 s, 35 s, 40 s, 50 s, 60 s, 70 s, 80 s, 90 s, 100 s, 120 s, 140 s, 150 s, 160 s, 180 s, 200 s, 210 s, 240 s, 300 s | 0,04 s, 0,1 s, 0,2 s, 0,3 s, 0,4 s, 0,5 s, 0,6 s, 0,7 s, 0,8 s, 1 s, 1,5 s, 2 s, 2,5 s, 3 s, 3,5 s, 4 s, 5 s, 6 s, 7 s, 8 s, 10 s, 12 s, 14 s, 15 s, 16 s, 20 s, 25 s, 30 s, 35 s, 40 s, 50 s, 60 s, 70 s, 80 s, 90 s, 100 s, 120 s, 140 s, 150 s, 160 s, 180 s, 200 s, 210 s, 240 s, 300 s |
| Time accuracy | +/-1 % + +/-20 ms | +/-1 % + +/-20 ms | +/-1 % + +/-20 ms |
| Repetition accuracy | +/-1 % + +/-20 ms | +/-1 % + +/-20 ms | +/-1 % + +/-20 ms |
| Repetition accuracy in the event of an error | +/-15 % + +/-20 ms | +/-15 % + +/-20 ms | +/-15 % + +/-20 ms |
| Max. delay time | $t_v + 15 \% + 20 \text{ ms}$ | $t_v + 15 \% + 20 \text{ ms}$ | $t_v + 15 \% + 20 \text{ ms}$ |
| Waiting period with a monitored start | | | |
| With rising edge | 150 ms | 150 ms | 150 ms |
| With falling edge | 240 ms | 240 ms | 240 ms |
| Min. start pulse duration with a monitored start | | | |
| With rising edge | 30 ms | 30 ms | 30 ms |
| With falling edge | 70 ms | 70 ms | 70 ms |
| Supply interruption before de-energisation | 20 ms | 20 ms | 20 ms |
| Simultaneity, channel 1 and 2 max. | ∞ | ∞ | ∞ |
| Environmental data | 750105 | 751105 | 751185 |
| Climatic suitability | EN 60068-2-78 | EN 60068-2-78 | EN 60068-2-78 |
| Ambient temperature | | | |
| Temperature range | -10 - 55 °C | -10 - 55 °C | -10 - 55 °C |
| Storage temperature | | | |
| Temperature range | -40 - 85 °C | -40 - 85 °C | -40 - 85 °C |
| Climatic suitability | | | |
| Humidity | 93 % r. h. at 40 °C | 93 % r. h. at 40 °C | 93 % r. h. at 40 °C |
| Condensation during operation | Not permitted | Not permitted | Not permitted |
| EMC | EN 60947-5-1, EN 61000-6-2, EN 61000-6-4, EN 61326-3-1 | EN 60947-5-1, EN 61000-6-2, EN 61000-6-4, EN 61326-3-1 | EN 60947-5-1, EN 61000-6-2, EN 61000-6-4, EN 61326-3-1 |

Safety relays PNOZsigma PNOZ s5

| Environmental data | 750105 | 751105 | 751185 |
|---|--|------------------------|------------------------|
| Vibration | | | |
| In accordance with the standard | EN 60068-2-6 | EN 60068-2-6 | EN 60068-2-6 |
| Frequency | 10 - 55 Hz | 10 - 55 Hz | 10 - 55 Hz |
| Amplitude | 0,35 mm | 0,35 mm | 0,35 mm |
| Airgap creepage | | | |
| In accordance with the standard | EN 60947-1 | EN 60947-1 | EN 60947-1 |
| Overvoltage category | III / II | III / II | III / II |
| Pollution degree | 2 | 2 | 2 |
| Rated insulation voltage | 250 V | 250 V | 250 V |
| Rated impulse withstand voltage | 4 kV | 4 kV | 4 kV |
| Protection type | | | |
| Mounting area (e.g. control cabinet) | IP54 | IP54 | IP54 |
| Housing | IP40 | IP40 | IP40 |
| Terminals | IP20 | IP20 | IP20 |
| Mechanical data | 750105 | 751105 | 751185 |
| Mounting position | Any | Any | Any |
| Mechanical life | 10,000,000 cycles | 10,000,000 cycles | 10,000,000 cycles |
| Material | | | |
| Bottom | PC | PC | PC |
| Front | PC | PC | PC |
| Top | PC | PC | PC |
| Connection type | Screw terminal | Spring-loaded terminal | Spring-loaded terminal |
| Mounting type | plug-in | plug-in | plug-in |
| Conductor cross section with screw terminals | | | |
| 1 core flexible | 0,25 - 2,5 mm ² , 24 - 12 AWG | — | — |
| 2 core with the same cross section, flexible with crimp connectors, no plastic sleeve | 0,25 - 1 mm ² , 24 - 16 AWG | — | — |
| 2 core with the same cross section, flexible without crimp connectors or with TWIN crimp connectors | 0,2 - 1,5 mm ² , 24 - 16 AWG | — | — |
| Torque setting with screw terminals | 0,5 Nm | — | — |

Safety relays PNOZsigma PNOZ s5

| Mechanical data | 750105 | 751105 | 751185 |
|---|---------|---|---|
| Conductor cross section with spring-loaded terminals: Flexible with/without crimp connector | – | 0,2 - 2,5 mm ² , 24 - 12 AWG | 0,2 - 2,5 mm ² , 24 - 12 AWG |
| Spring-loaded terminals: Terminal points per connection | – | 2 | 2 |
| Stripping length with spring-loaded terminals | – | 9 mm | 9 mm |
| Dimensions | | | |
| Height | 98 mm | 100 mm | 100 mm |
| Width | 22,5 mm | 22,5 mm | 22,5 mm |
| Depth | 120 mm | 120 mm | 120 mm |
| Weight | 235 g | 235 g | 235 g |

Where standards are undated, the 2014-07 latest editions shall apply.

Order no. 750135 –751135

| General | 750135 | 751135 |
|--------------------------------------|---|---|
| Approvals | CCC, CE, EAC (Eurasian), KOSHA, TÜV, cULus Listed | CCC, CE, EAC (Eurasian), KOSHA, TÜV, cULus Listed |
| Electrical data | 750135 | 751135 |
| Supply voltage | | |
| Voltage | 48 - 240 V | 48 - 240 V |
| Kind | AC/DC | AC/DC |
| Voltage tolerance | -15 %/+10 % | -15 %/+10 % |
| Output of external power supply (AC) | 8 VA | 8 VA |
| Output of external power supply (DC) | 4 W | 4 W |
| Frequency range AC | 50 - 60 Hz | 50 - 60 Hz |
| Residual ripple DC | 160 % | 160 % |
| Duty cycle | 100 % | 100 % |
| Inputs | 750135 | 751135 |
| Number | 2 | 2 |
| Voltage at | | |
| Input circuit DC | 24 V | 24 V |
| Start circuit DC | 24 V | 24 V |
| Feedback loop DC | 24 V | 24 V |

Safety relays PNOZsigma PNOZ s5

| Inputs | 750135 | 751135 |
|---|--------------|--------------|
| Current at | | |
| Input circuit DC | 40 mA | 40 mA |
| Start circuit DC | 40 mA | 40 mA |
| Feedback loop DC | 40 mA | 40 mA |
| Max. inrush current impulse | | |
| Current pulse, input circuit | 0,2 A | 0,2 A |
| Pulse duration, input circuit | 100 ms | 100 ms |
| Current pulse, feedback loop | 0,2 A | 0,2 A |
| Pulse duration, feedback loop | 60 ms | 60 ms |
| Current pulse, start circuit | 0,2 A | 0,2 A |
| Pulse duration, start circuit | 60 ms | 60 ms |
| Min. input resistance at power-on | 110 Ohm | 110 Ohm |
| Max. overall cable resistance RI-max | | |
| Single-channel at UB DC | 30 Ohm | 30 Ohm |
| Single-channel at UB AC | 30 Ohm | 30 Ohm |
| Dual-channel without detection of shorts across contacts at UB DC | 30 Ohm | 30 Ohm |
| Dual-channel without detection of shorts across contacts at UB AC | 30 Ohm | 30 Ohm |
| Dual-channel with detection of shorts across contacts at UB DC | 30 Ohm | 30 Ohm |
| Dual-channel with detection of shorts across contacts at UB AC | 30 Ohm | 30 Ohm |
| Semiconductor outputs | | |
| Number | 1 | 1 |
| Voltage | 24 V | 24 V |
| Current | 20 mA | 20 mA |
| Relay outputs | | |
| Number of output contacts | | |
| Safety contacts (N/O), instantaneous | 2 | 2 |
| Safety contacts (N/O), delayed | 2 | 2 |
| Max. short circuit current I _K | 1 kA | 1 kA |
| Utilisation category | | |
| In accordance with the standard | EN 60947-4-1 | EN 60947-4-1 |

Safety relays PNOZsigma PNOZ s5

| Relay outputs | 750135 | 751135 |
|---|-------------------------------|-------------------------------|
| Utilisation category of safety contacts | | |
| AC1 at | 240 V | 240 V |
| Min. current | 0,01 A | 0,01 A |
| Max. current | 6 A | 6 A |
| Max. power | 1500 VA | 1500 VA |
| DC1 at | 24 V | 24 V |
| Min. current | 0,01 A | 0,01 A |
| Max. current | 6 A | 6 A |
| Max. power | 150 W | 150 W |
| Utilisation category of safety contacts delayed | | |
| AC1 at | 240 V | 240 V |
| Min. current | 0,01 A | 0,01 A |
| Max. current | 6 A | 6 A |
| Max. power | 1500 VA | 1500 VA |
| DC1 at | 24 V | 24 V |
| Min. current | 0,01 A | 0,01 A |
| Max. current | 6 A | 6 A |
| Max. power | 150 W | 150 W |
| Utilisation category | | |
| In accordance with the standard | EN 60947-5-1 | EN 60947-5-1 |
| Utilisation category of safety contacts | | |
| AC15 at | 230 V | 230 V |
| Max. current | 3 A | 3 A |
| DC13 (6 cycles/min) at | 24 V | 24 V |
| Max. current | 4 A | 4 A |
| Utilisation category of safety contacts delayed | | |
| AC15 at | 230 V | 230 V |
| Max. current | 3 A | 3 A |
| DC13 (6 cycles/min) at | 24 V | 24 V |
| Max. current | 4 A | 4 A |
| Utilisation category in accordance with UL | | |
| Voltage | 240 V AC G.U. (same polarity) | 240 V AC G.U. (same polarity) |
| With current | 6 A | 6 A |
| Voltage | 24 V DC G. U. | 24 V DC G. U. |
| With current | 6 A | 6 A |
| Pilot Duty | B300, R300 | B300, R300 |

Safety relays PNOZsigma PNOZ s5

| Relay outputs | 750135 | 751135 |
|--|---------------------------|---------------------------|
| External contact fuse protection, safety contacts | | |
| In accordance with the standard | EN 60947-5-1 | EN 60947-5-1 |
| Max. melting integral | 66 A²s | 66 A²s |
| Blow-out fuse, quick | 6 A | 6 A |
| Blow-out fuse, slow | 4 A | 4 A |
| Blow-out fuse, gG | 6 A | 6 A |
| Circuit breaker 24V AC/DC, characteristic B/C | 4 A | 4 A |
| External contact fuse protection, delayed safety contacts | | |
| Max. melting integral | 66 A²s | 66 A²s |
| Blow-out fuse, quick | 6 A | 6 A |
| Blow-out fuse, slow | 4 A | 4 A |
| Blow-out fuse, gG | 6 A | 6 A |
| Circuit breaker 24 V AC/DC, characteristic B/C | 4 A | 4 A |
| Contact material | AgCuNi + 0,2 µm Au | AgCuNi + 0,2 µm Au |
| Conventional thermal current while loading several contacts | 750135 | 751135 |
| I _{th} per contact at UB AC; AC1: 240 V, DC1: 24 V | | |
| Conv. therm. current with 1 contact | 6 A | 6 A |
| Conv. therm. current with 2 contacts | 6 A | 6 A |
| Conv. therm. current with 3 contacts | 6 A | 6 A |
| Conv. therm. current with 4 contacts | 6 A | 6 A |
| I _{th} per contact at UB DC; AC1: 240 V, DC1: 24 V | | |
| Conv. therm. current with 1 contact | 6 A | 6 A |
| Conv. therm. current with 2 contacts | 6 A | 6 A |
| Conv. therm. current with 3 contacts | 6 A | 6 A |
| Conv. therm. current with 4 contacts | 6 A | 6 A |

Safety relays PNOZsigma PNOZ s5

| Times | 750135 | 751135 |
|---|---|---|
| Switch-on delay | | |
| With automatic start typ. | 180 ms | 180 ms |
| With automatic start max. | 330 ms | 330 ms |
| With automatic start after power on typ. | 1.430 ms | 1.430 ms |
| With automatic start after power on max. | 1.900 ms | 1.900 ms |
| With automatic start after power on typ. | – | – |
| With automatic start after power on max. | – | – |
| With manual start typ. | 45 ms | 45 ms |
| With manual start max. | 85 ms | 85 ms |
| With monitored start with rising edge typ. | 45 ms | 45 ms |
| With monitored start with rising edge max. | 70 ms | 70 ms |
| With monitored start with falling edge typ. | 60 ms | 60 ms |
| With monitored start with falling edge max. | 80 ms | 80 ms |
| Delay-on de-energisation | | |
| With E-STOP typ. | 15 ms | 15 ms |
| With E-STOP max. | 20 ms | 20 ms |
| With power failure typ. | 75 ms | 75 ms |
| With power failure max. | 110 ms | 110 ms |
| Recovery time at max. switching frequency 1/s | | |
| After E-STOP | 150 ms +tv | 150 ms +tv |
| After power failure | 200 ms | 200 ms |
| Delay time tv | 0,04 s, 0,1 s, 0,2 s, 0,3 s, 0,4 s, 0,5 s, 0,6 s, 0,7 s, 0,8 s, 1 s, 1,5 s, 2 s, 2,5 s, 3 s, 3,5 s, 4 s, 5 s, 6 s, 7 s, 8 s, 10 s, 12 s, 14 s, 15 s, 16 s, 20 s, 25 s, 30 s, 35 s, 40 s, 50 s, 60 s, 70 s, 80 s, 90 s, 100 s, 120 s, 140 s, 150 s, 160 s, 180 s, 200 s, 210 s, 240 s, 300 s | 0,04 s, 0,1 s, 0,2 s, 0,3 s, 0,4 s, 0,5 s, 0,6 s, 0,7 s, 0,8 s, 1 s, 1,5 s, 2 s, 2,5 s, 3 s, 3,5 s, 4 s, 5 s, 6 s, 7 s, 8 s, 10 s, 12 s, 14 s, 15 s, 16 s, 20 s, 25 s, 30 s, 35 s, 40 s, 50 s, 60 s, 70 s, 80 s, 90 s, 100 s, 120 s, 140 s, 150 s, 160 s, 180 s, 200 s, 210 s, 240 s, 300 s |
| Time accuracy | +/-1 % + +/-20 ms | +/-1 % + +/-20 ms |
| Repetition accuracy | +/-1 % + +/-20 ms | +/-1 % + +/-20 ms |
| Repetition accuracy in the event of an error | +/-15 % + +/-20 ms | +/-15 % + +/-20 ms |
| Max. delay time | tv + 15 % + 20 ms | tv + 15 % + 20 ms |

Safety relays PNOZsigma PNOZ s5

| Times | 750135 | 751135 |
|--|--|--|
| Waiting period with a monitored start | | |
| With rising edge | 150 ms | 150 ms |
| With falling edge | 240 ms | 240 ms |
| Min. start pulse duration with a monitored start | | |
| With rising edge | 30 ms | 30 ms |
| With falling edge | 70 ms | 70 ms |
| Supply interruption before de-energisation | 20 ms | 20 ms |
| Simultaneity, channel 1 and 2 max. | ∞ | ∞ |
| Environmental data | 750135 | 751135 |
| Climatic suitability | EN 60068-2-78 | EN 60068-2-78 |
| Ambient temperature | | |
| Temperature range | -10 - 55 °C | -10 - 55 °C |
| Storage temperature | | |
| Temperature range | -40 - 85 °C | -40 - 85 °C |
| Climatic suitability | | |
| Humidity | 93 % r. h. at 40 °C | 93 % r. h. at 40 °C |
| Condensation during operation | Not permitted | Not permitted |
| EMC | EN 60947-5-1, EN 61000-6-2, EN 61000-6-4, EN 61326-3-1 | EN 60947-5-1, EN 61000-6-2, EN 61000-6-4, EN 61326-3-1 |
| Vibration | | |
| In accordance with the standard | EN 60068-2-6 | EN 60068-2-6 |
| Frequency | 10 - 55 Hz | 10 - 55 Hz |
| Amplitude | 0,35 mm | 0,35 mm |
| Airgap creepage | | |
| In accordance with the standard | EN 60947-1 | EN 60947-1 |
| Overvoltage category | III / II | III / II |
| Pollution degree | 2 | 2 |
| Rated insulation voltage | 250 V | 250 V |
| Rated impulse withstand voltage | 4 kV | 4 kV |
| Protection type | | |
| Mounting area (e.g. control cabinet) | IP54 | IP54 |
| Housing | IP40 | IP40 |
| Terminals | IP20 | IP20 |
| Mechanical data | 750135 | 751135 |
| Mounting position | Any | Any |
| Mechanical life | 10,000,000 cycles | 10,000,000 cycles |

Safety relays PNOZsigma PNOZ s5

| Mechanical data | 750135 | 751135 |
|---|--|---|
| Material | | |
| Bottom | PC | PC |
| Front | PC | PC |
| Top | PC | PC |
| Connection type | Screw terminal | Spring-loaded terminal |
| Mounting type | plug-in | plug-in |
| Conductor cross section with screw terminals | | |
| 1 core flexible | 0,25 - 2,5 mm ² , 24 - 12 AWG | – |
| 2 core with the same cross section, flexible with crimp connectors, no plastic sleeve | 0,25 - 1 mm ² , 24 - 16 AWG | – |
| 2 core with the same cross section, flexible without crimp connectors or with TWIN crimp connectors | 0,2 - 1,5 mm ² , 24 - 16 AWG | – |
| Torque setting with screw terminals | 0,5 Nm | – |
| Conductor cross section with spring-loaded terminals: Flexible with/without crimp connector | – | 0,2 - 2,5 mm ² , 24 - 12 AWG |
| Spring-loaded terminals: Terminal points per connection | – | 2 |
| Stripping length with spring-loaded terminals | – | 9 mm |
| Dimensions | | |
| Height | 98 mm | 100 mm |
| Width | 22,5 mm | 22,5 mm |
| Depth | 120 mm | 120 mm |
| Weight | 255 g | 255 g |

Where standards are undated, the 2014-07 latest editions shall apply.

Safety relays PNOZsigma PNOZ s5

Safety characteristic data

| Operating Mode | EN ISO 13849-1: 2015 PL | EN ISO 13849-1: 2015 Category | EN 62061 SIL CL | EN 62061 PFH _D [1/h] | IEC 61511 SIL | IEC 61511 PFD | EN ISO 13849-1: 2015 T _M [year] |
|--------------------------------|----------------------------|----------------------------------|--------------------|------------------------------------|------------------|------------------|---|
| Safety contacts, instantaneous | PL e | Cat. 4 | SIL CL 3 | 2,31E-09 | SIL 3 | 2,03E-06 | 20 |
| Safety contacts, delayed | PL e | Cat. 4 | SIL CL 3 | 2,34E-09 | SIL 3 | 2,75E-05 | 20 |

All the units used within a safety function must be considered when calculating the safety characteristic data.

The PFH value depends on the switching frequency and the load on the relay output. If the service life graphs are not accessible, the stated PFH value can be used irrespective of the switching frequency and the load, as the PFH value already considers the relay's B10d value as well as the failure rates of the other components.

Supplementary data

The PFH value depends on the switching frequency and the load on the relay output. If the service life graphs are not accessible, the stated PFH value can be used irrespective of the switching frequency and the load, as the PFH value already considers the relay's B10d value as well as the failure rates of the other components.

Safety relays PNOZsigma PNOZ s5

Service life graph

The service life graphs indicate the number of cycles from which failures due to wear must be expected. The wear is mainly caused by the electrical load; the mechanical load is negligible.

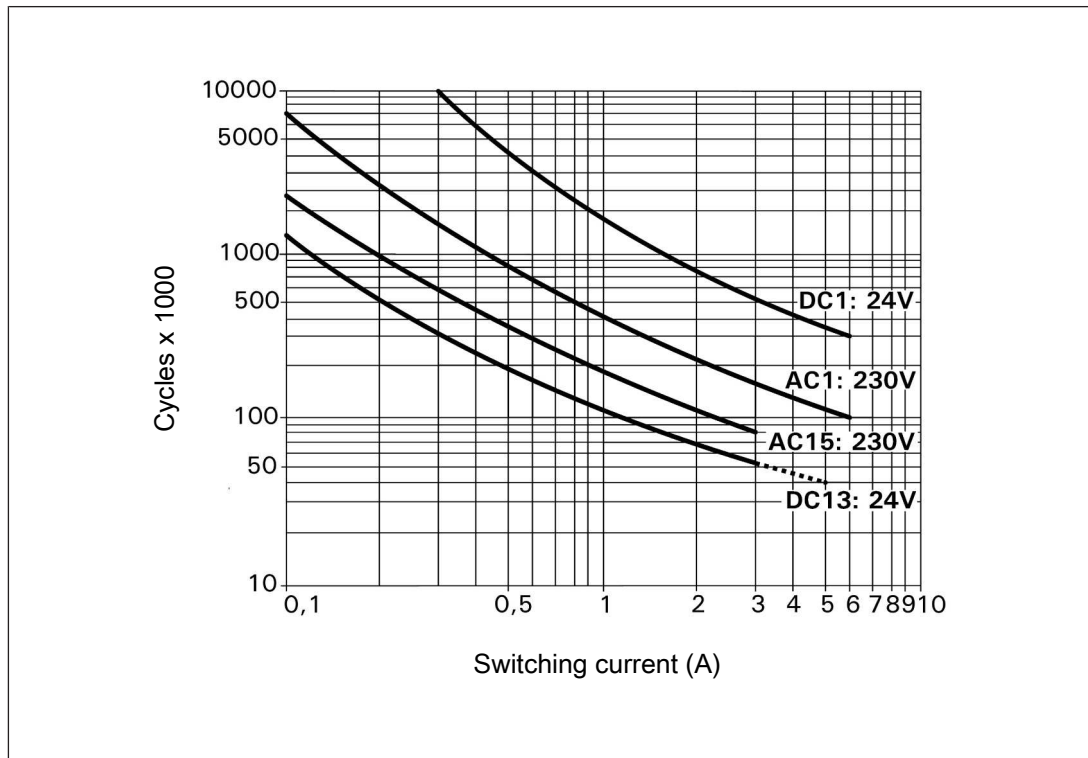

Fig.: Service life graphs at 24 V DC and 230 V AC

Safety relays PNOZsigma PNOZ s5

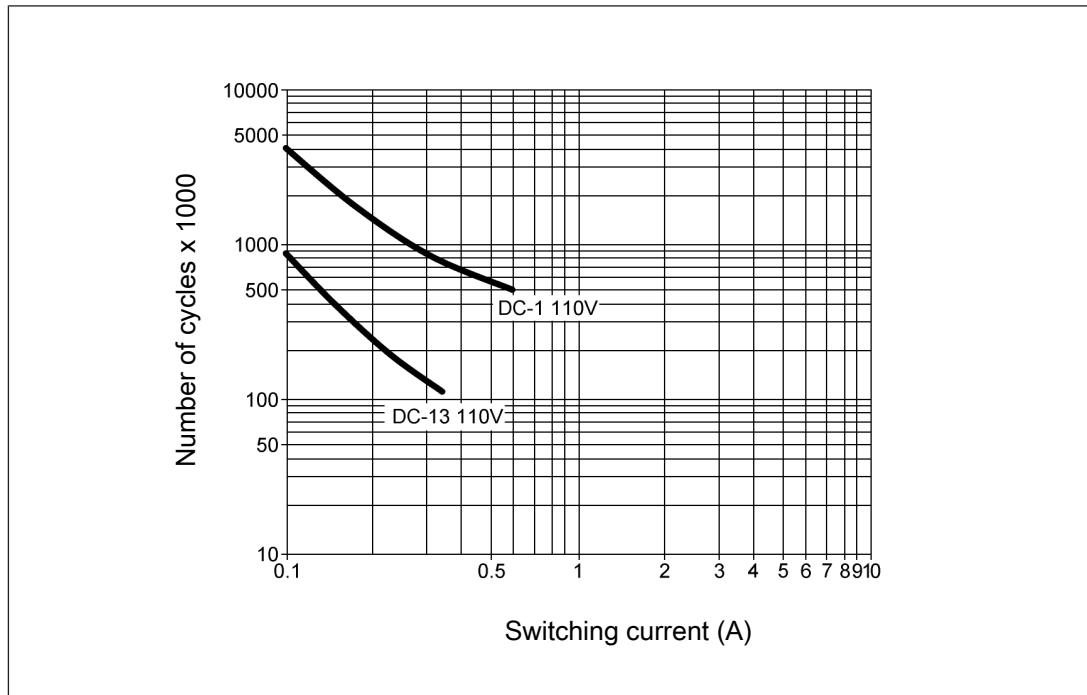

Fig.: Service life graphs at 110 V DC

Example

- ▶ Inductive load: 0.2 A
- ▶ Utilisation category: AC15
- ▶ Contact service life: 1 000 000 cycles

Provided the application to be implemented requires fewer than 1 000 000 cycles, the PFH value (see [Technical details \[644\]](#)) can be used in the calculation.

To increase the service life, sufficient spark suppression must be provided on all relay contacts. With capacitive loads, any power surges that occur must be noted. With DC contactors, use flywheel diodes for spark suppression.

Order reference

| Product type | Features | Connection type | Order No. |
|-------------------------------|-----------------|-------------------------|-----------|
| PNOZ s5 | 24 VDC | Screw terminals | 750 105 |
| PNOZ s5 C | 24 VDC | Spring-loaded terminals | 751 105 |
| PNOZ s5 C (coated version) | 24 VDC | Spring-loaded terminals | 751 185 |
| PNOZ s5 | 48 - 240 VAC/DC | Screw terminals | 750 135 |
| PNOZ s5 C | 48 - 240 VAC/DC | Spring-loaded terminals | 751 135 |

Safety relays PNOZsigma PNOZ s6

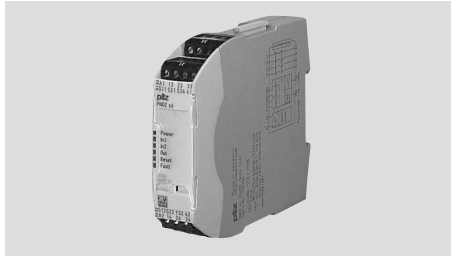

Unit features

- ▶ Positive-guided relay outputs:
 - 3 safety contacts (N/O), instantaneous
 - 1 auxiliary contact (N/C), instantaneous
- ▶ 1 semiconductor output
- ▶ Connection options for:
 - 2 control elements (pushbuttons)
- ▶ A connector can be used to connect 1 PNOZsigma contact expansion module
- ▶ LED for:
 - Supply voltage
 - Input status, channel 1
 - Input status, channel 2
 - Switch status of the safety contacts
 - Feedback loop
 - Fault
- ▶ Plug-in connection terminals (either spring-loaded terminal or screw terminal)
- ▶ See order reference for unit types

Safety relays PNOZsigma PNOZ s6

Block diagram/terminal configuration

Unit types with UB 24 VDC

- ▶ U_B : 24 VDC; Order no. 750106, 751106

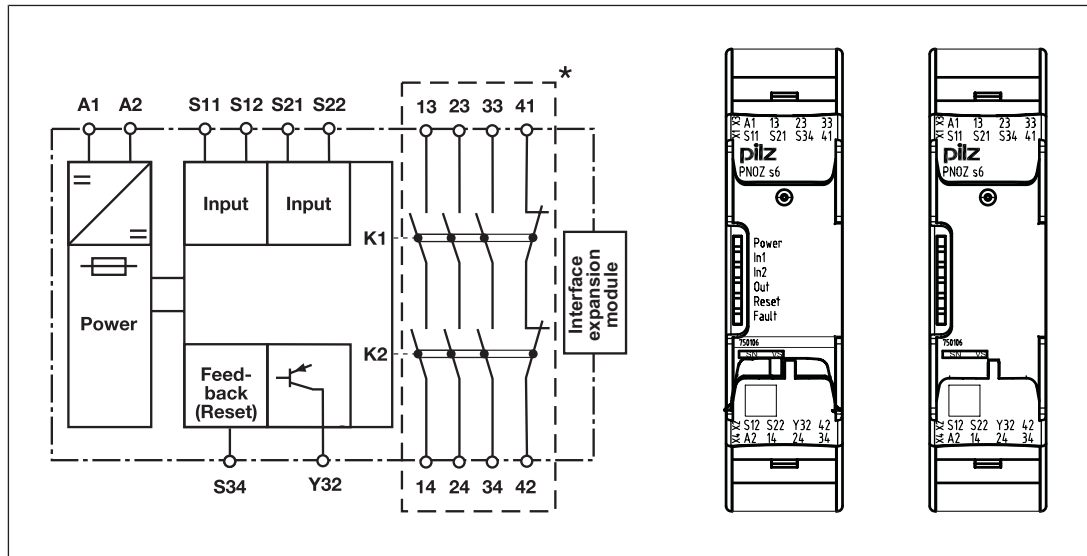

Fig.: Centre: Front view with cover, right: Front view without cover

*Insulation between the non-marked area and the relay contacts: Basic insulation (over-voltage category III), Protective separation (overvoltage category II)

Safety relays PNOZsigma PNOZ s6

Unit types with UB 48 - 240 VAC/DC

- ▶ U_B : 48 - 240 VAC/DC; Order no. 750136, 751136

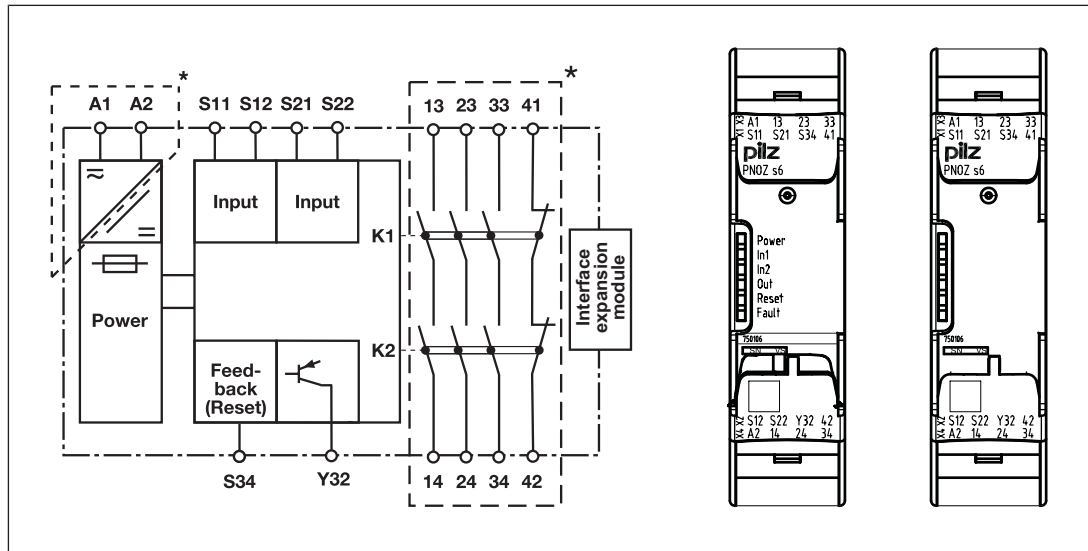

Fig.: Centre: Front view with cover, right: Front view without cover

*Insulation between the non-marked area and the relay contacts: Basic insulation (over-voltage category III), Protective separation (overvoltage category II)

Function description

- ▶ The two-hand control relay must be activated by simultaneously pressing two buttons within 0,5 s. If one or both of the buttons are released, the unit interrupts the control command for the hazardous movement.
- ▶ Reactivation: The output relays will not re-energise until both operator elements have been released and then re-operated simultaneously.

Safety relays PNOZsigma PNOZ s6

Timing diagram

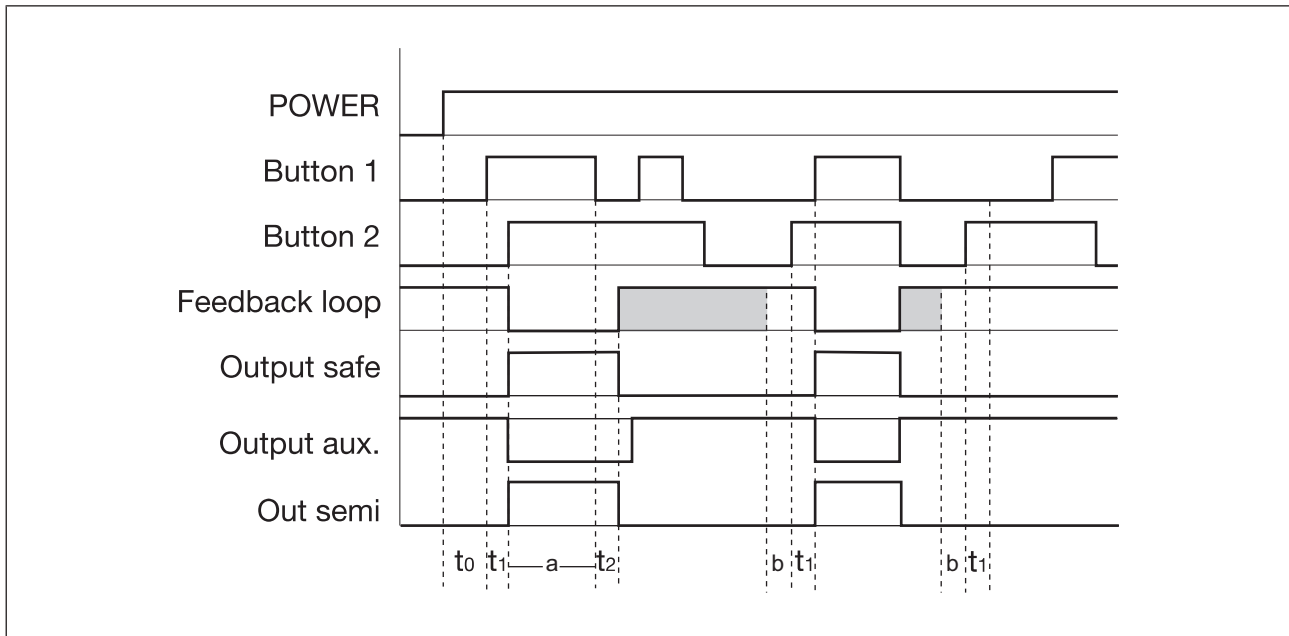

Legend

- ▶ POWER: Supply voltage
- ▶ Button 1/Button 2: Input circuits
- ▶ Feedback loop: Feedback loop
- ▶ Output safe: Safety outputs
- ▶ Output aux.: Auxiliary contacts
- ▶ Out semi: Semiconductor output switch status
- ▶ t_0 : Recovery time after power on
- ▶ t_1 : Simultaneity, channel 1 and 2
- ▶ t_2 : Delay-on de-energisation
- ▶ a : Operating cycle ended through button 1 or 2
- ▶ b : S34-S12 must be closed before the button is operated

Shaded area: Status irrelevant

Safety relays PNOZsigma PNOZ s6

Installation

Install base unit without contact expansion module:

- ▶ Ensure that the plug terminator is inserted at the side of the unit.

Connect base unit and PNOZsigma contact expansion module:

- ▶ Remove the plug terminator at the side of the base unit and at the contact expansion module.
- ▶ Connect the base unit and the contact expansion module to the supplied connector before mounting the units to the DIN rail.

Installation in control cabinet

- ▶ The safety relay should be installed in a control cabinet with a protection type of at least IP54.
- ▶ Use the notch on the rear of the unit to attach it to a DIN rail (35 mm).
- ▶ When installed vertically: Secure the unit by using a fixing element (e.g. retaining bracket or end angle).
- ▶ Push the device upwards or downwards before lifting it from the DIN rail.

Wiring

Please note:

- ▶ Information given in the "[Technical details \[667\]](#)" must be followed.
- ▶ Outputs 13-14, 23-24, 33-34 are safety contacts; output 41-42 is an auxiliary contact (e.g. for display).
- ▶ Auxiliary contact 41-42 and semiconductor output Y32 should **not** be used for safety circuits!
- ▶ To prevent contact welding, a fuse should be connected before the output contacts (see [Technical details \[667\]](#)).
- ▶ Calculation of the max. cable length l_{\max} in the input circuit:

$$l_{\max} = \frac{R_{l\max}}{R_l / \text{km}}$$

$R_{l\max}$ = max. overall cable resistance (see [Technical details \[667\]](#))

R_l / km = cable resistance/km

- ▶ Use copper wire that can withstand 60/75 °C.
- ▶ Sufficient fuse protection must be provided on all output contacts with capacitive and inductive loads.
- ▶ With U_B 48 – 240 VAC/DC: Connect S22 to functional earth.
- ▶ Ensure the wiring and EMC requirements of IEC 60204-1 are met.
- ▶ On 24 VDC devices:
The power supply must comply with the regulations for extra low voltages with protective electrical separation (SELV, PELV) in accordance with VDE 0100, Part 410.

Safety relays PNOZsigma PNOZ s6

Preparing for operation

| Supply voltage | Unit types with U_B 48-240 VAC/DC | Unit types with U_B 240 VDC |
|--|-------------------------------------|----------------------------------|
| | | |
| Input circuit | Single-channel | Dual-channel |
| Two-hand button with detection of shorts across contacts | | |
| Feedback loop | with feedback loop monitoring | without feedback loop monitoring |
| Link or contacts from external contactors | | |
| Semiconductor output | | |
| | | |

Legend

- ▶ S1/S2: Two-hand pushbuttons

Safety relays PNOZsigma PNOZ s6

Dimensions in mm

*with spring-loaded terminals

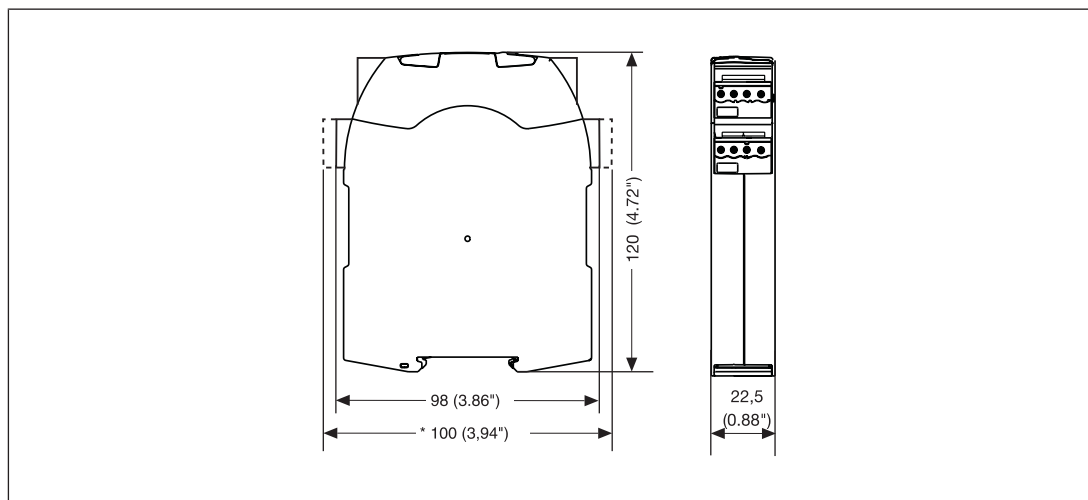

Technical details

Order no. 750106 – 750136

See below for more order numbers

| General | 750106 | 750136 |
|--|--|--|
| Approvals | CCC, CE, EAC (Eurasian), KOSHA, TÜV, cULus Listed | CCC, CE, EAC (Eurasian), KOSHA, TÜV, cULus Listed |
| Electrical data | 750106 | 750136 |
| Supply voltage | | |
| Voltage | 24 V | 48 - 240 V |
| Kind | DC | AC/DC |
| Voltage tolerance | -15 %/+10 % | -15 %/+10 % |
| Output of external power supply (AC) | – | 7 VA |
| Output of external power supply (DC) | 3,5 W | 3,5 W |
| Frequency range AC | – | 50 - 60 Hz |
| Residual ripple DC | 20 % | 20 % |
| Duty cycle | 100 % | 100 % |
| Current at | | |
| Normally open contact | 20 mA | 20 mA |
| N/C | 10 mA | 10 mA |
| Max. overall cable resistance RI-max per input circuit | 30 Ohm | 30 Ohm |

Safety relays PNOZsigma PNOZ s6

| Electrical data | 750106 | 750136 |
|---|-------------------------------------|-------------------------------------|
| External unit fuse protection F1 min. | 1 A | 1 A |
| External unit fuse protection F1 max. | Max. conductor cross section | Max. conductor cross section |
| Two-hand control relay type | | |
| In accordance with the standard | EN 574 | EN 574 |
| Type | III C | III C |
| Inputs | 750106 | 750136 |
| Number | 2 | 2 |
| Voltage at | | |
| Input circuit DC | 24 V | 24 V |
| Feedback loop DC | 24 V | 24 V |
| Current at | | |
| Feedback loop DC | 15 mA | 15 mA |
| Semiconductor outputs | 750106 | 750136 |
| Number | 1 | 1 |
| Voltage | 24 V | 24 V |
| Current | 20 mA | 20 mA |
| Relay outputs | 750106 | 750136 |
| Number of output contacts | | |
| Safety contacts (N/O), instantaneous | 3 | 3 |
| Auxiliary contacts (N/C) | 1 | 1 |
| Max. short circuit current IK | 1 kA | 1 kA |
| Utilisation category | | |
| In accordance with the standard | EN 60947-4-1 | EN 60947-4-1 |
| Utilisation category of safety contacts | | |
| AC1 at | 240 V | 240 V |
| Min. current | 0,01 A | 0,01 A |
| Max. current | 6 A | 6 A |
| Max. power | 1500 VA | 1500 VA |
| DC1 at | 24 V | 24 V |
| Min. current | 0,01 A | 0,01 A |
| Max. current | 6 A | 6 A |
| Max. power | 150 W | 150 W |

Safety relays PNOZsigma PNOZ s6

| Relay outputs | 750106 | 750136 |
|---|-------------------------------|-------------------------------|
| Utilisation category of auxiliary contacts | | |
| AC1 at | 240 V | 240 V |
| Min. current | 0,01 A | 0,01 A |
| Max. current | 6 A | 6 A |
| Max. power | 1500 VA | 1500 VA |
| DC1 at | 24 V | 24 V |
| Min. current | 0,01 A | 0,01 A |
| Max. current | 6 A | 6 A |
| Max. power | 150 W | 150 W |
| Utilisation category | | |
| In accordance with the standard | EN 60947-5-1 | EN 60947-5-1 |
| Utilisation category of safety contacts | | |
| AC15 at | 230 V | 230 V |
| Max. current | 5 A | 3 A |
| DC13 (6 cycles/min) at | 24 V | 24 V |
| Max. current | 5 A | 4 A |
| Utilisation category of auxiliary contacts | | |
| AC15 at | 230 V | 230 V |
| Max. current | 5 A | 3 A |
| DC13 (6 cycles/min) at | 24 V | 24 V |
| Max. current | 5 A | 4 A |
| Utilisation category in accordance with UL | | |
| Voltage | 240 V AC G.U. (same polarity) | 240 V AC G.U. (same polarity) |
| With current | 6 A | 6 A |
| Voltage | 24 V DC G. U. | 24 V DC G. U. |
| With current | 6 A | 6 A |
| External contact fuse protection, safety contacts | | |
| In accordance with the standard | EN 60947-5-1 | EN 60947-5-1 |
| Max. melting integral | 260 A ² s | 66 A ² s |
| Blow-out fuse, quick | 10 A | 6 A |
| Blow-out fuse, slow | 6 A | 4 A |
| Blow-out fuse, gG | 10 A | 6 A |
| Circuit breaker 24V AC/DC, characteristic B/C | 6 A | 4 A |

Safety relays PNOZsigma PNOZ s6

| Relay outputs | 750106 | 750136 |
|--|----------------------|---------------------|
| External contact fuse protection, auxiliary contacts | | |
| Max. melting integral | 160 A ² s | 66 A ² s |
| Blow-out fuse, quick | 10 A | 6 A |
| Blow-out fuse, slow | 6 A | 4 A |
| Blow-out fuse, gG | 6 A | 6 A |
| Circuit breaker 24 V AC/DC, characteristic B/C | 6 A | 4 A |
| Contact material | AgCuNi + 0,2 µm Au | AgCuNi + 0,2 µm Au |
| Conventional thermal current while loading several contacts | 750106 | 750136 |
| I _{th} per contact at UB AC; AC1: 240 V, DC1: 24 V | | |
| Conv. therm. current with 1 contact | – | 6 A |
| Conv. therm. current with 2 contacts | – | 6 A |
| Conv. therm. current with 3 contacts | – | 4,5 A |
| I _{th} per contact at UB DC; AC1: 240 V, DC1: 24 V | | |
| Conv. therm. current with 1 contact | 6 A | 6 A |
| Conv. therm. current with 2 contacts | 6 A | 6 A |
| Conv. therm. current with 3 contacts | 6 A | 4,5 A |
| Times | 750106 | 750136 |
| Delay-on de-energisation (response time in accordance with EN 574) | | |
| Normally open contact | 30 ms | 30 ms |
| N/C | 40 ms | 40 ms |
| Recovery time | 250 ms | 250 ms |
| Supply interruption before de-energisation | 20 ms | 20 ms |
| Simultaneity, channel 1 and 2 max. | 0,5 s | 0,5 s |
| Environmental data | 750106 | 750136 |
| Climatic suitability | EN 60068-2-78 | EN 60068-2-78 |
| Ambient temperature | | |
| Temperature range | -10 - 55 °C | -10 - 55 °C |
| Storage temperature | | |
| Temperature range | -40 - 85 °C | -40 - 85 °C |

Safety relays PNOZsigma PNOZ s6

| Environmental data | 750106 | 750136 |
|---|--|--|
| Climatic suitability | | |
| Humidity | 93 % r. h. at 40 °C | 93 % r. h. at 40 °C |
| Condensation during operation | Not permitted | Not permitted |
| EMC | EN 60947-5-1, EN 61000-6-2, EN 61000-6-4, EN 61326-3-1 | EN 60947-5-1, EN 61000-6-2, EN 61000-6-4, EN 61326-3-1 |
| Vibration | | |
| In accordance with the standard | EN 60068-2-6 | EN 60068-2-6 |
| Frequency | 10 - 55 Hz | 10 - 55 Hz |
| Amplitude | 0,35 mm | 0,35 mm |
| Airgap creepage | | |
| In accordance with the standard | EN 60947-1 | EN 60947-1 |
| Overvoltage category | III / II | III / II |
| Pollution degree | 2 | 2 |
| Rated insulation voltage | 250 V | 250 V |
| Rated impulse withstand voltage | 4 kV | 4 kV |
| Protection type | | |
| Mounting area (e.g. control cabinet) | IP54 | IP54 |
| Housing | IP40 | IP40 |
| Terminals | IP20 | IP20 |
| Mechanical data | 750106 | 750136 |
| Mounting position | Any | Any |
| Mechanical life | 10,000,000 cycles | 10,000,000 cycles |
| Material | | |
| Bottom | PC | PC |
| Front | PC | PC |
| Top | PC | PC |
| Connection type | Screw terminal | Screw terminal |
| Mounting type | plug-in | plug-in |
| Conductor cross section with screw terminals | | |
| 1 core flexible | 0,25 - 2,5 mm ² , 24 - 12 AWG | 0,25 - 2,5 mm ² , 24 - 12 AWG |
| 2 core with the same cross section, flexible with crimp connectors, no plastic sleeve | 0,25 - 1 mm ² , 24 - 16 AWG | 0,25 - 1 mm ² , 24 - 16 AWG |
| 2 core with the same cross section, flexible without crimp connectors or with TWIN crimp connectors | 0,2 - 1,5 mm ² , 24 - 16 AWG | 0,2 - 1,5 mm ² , 24 - 16 AWG |
| Torque setting with screw terminals | 0,5 Nm | 0,5 Nm |

Safety relays PNOZsigma PNOZ s6

| Mechanical data | 750106 | 750136 |
|-----------------|---------|---------|
| Dimensions | | |
| Height | 98 mm | 98 mm |
| Width | 22,5 mm | 22,5 mm |
| Depth | 120 mm | 120 mm |
| Weight | 185 g | 205 g |

Where standards are undated, the 2014-07 latest editions shall apply.

Order no. 751106 – 751136

| General | 751106 | 751136 |
|--|--|--|
| Approvals | CCC, CE, EAC (Eurasian), KOSHA, TÜV, cULus Listed | CCC, CE, EAC (Eurasian), KOSHA, TÜV, cULus Listed |
| Electrical data | 751106 | 751136 |
| Supply voltage | | |
| Voltage | 24 V | 48 - 240 V |
| Kind | DC | AC/DC |
| Voltage tolerance | -15 %/+10 % | -15 %/+10 % |
| Output of external power supply (AC) | – | 7 VA |
| Output of external power supply (DC) | 3,5 W | 3,5 W |
| Frequency range AC | – | 50 - 60 Hz |
| Residual ripple DC | 20 % | 20 % |
| Duty cycle | 100 % | 100 % |
| Current at | | |
| Normally open contact | 20 mA | 20 mA |
| N/C | 10 mA | 10 mA |
| Max. overall cable resistance RI- max per input circuit | 30 Ohm | 30 Ohm |
| External unit fuse protection F1 min. | 1 A | 1 A |
| External unit fuse protection F1 max. | Max. conductor cross section | Max. conductor cross section |
| Two-hand control relay type | | |
| In accordance with the standard | EN 574 | EN 574 |
| Type | III C | III C |
| Inputs | 751106 | 751136 |
| Number | 2 | 2 |

Safety relays PNOZsigma PNOZ s6

| Inputs | 751106 | 751136 |
|--|---------------|---------------|
| Voltage at | | |
| Input circuit DC | 24 V | 24 V |
| Feedback loop DC | 24 V | 24 V |
| Current at | | |
| Feedback loop DC | 15 mA | 15 mA |
| Semiconductor outputs | 751106 | 751136 |
| Number | 1 | 1 |
| Voltage | 24 V | 24 V |
| Current | 20 mA | 20 mA |
| Relay outputs | 751106 | 751136 |
| Number of output contacts | | |
| Safety contacts (N/O), instantaneous | 3 | 3 |
| Auxiliary contacts (N/C) | 1 | 1 |
| Max. short circuit current I _K | 1 kA | 1 kA |
| Utilisation category | | |
| In accordance with the standard | EN 60947-4-1 | EN 60947-4-1 |
| Utilisation category of safety contacts | | |
| AC1 at | 240 V | 240 V |
| Min. current | 0,01 A | 0,01 A |
| Max. current | 6 A | 6 A |
| Max. power | 1500 VA | 1500 VA |
| DC1 at | 24 V | 24 V |
| Min. current | 0,01 A | 0,01 A |
| Max. current | 6 A | 6 A |
| Max. power | 150 W | 150 W |
| Utilisation category of auxiliary contacts | | |
| AC1 at | 240 V | 240 V |
| Min. current | 0,01 A | 0,01 A |
| Max. current | 6 A | 6 A |
| Max. power | 1500 VA | 1500 VA |
| DC1 at | 24 V | 24 V |
| Min. current | 0,01 A | 0,01 A |
| Max. current | 6 A | 6 A |
| Max. power | 150 W | 150 W |
| Utilisation category | | |
| In accordance with the standard | EN 60947-5-1 | EN 60947-5-1 |

Safety relays PNOZsigma PNOZ s6

| Relay outputs | 751106 | 751136 |
|--|--------------------------------------|--------------------------------------|
| Utilisation category of safety contacts | | |
| AC15 at | 230 V | 230 V |
| Max. current | 5 A | 3 A |
| DC13 (6 cycles/min) at | 24 V | 24 V |
| Max. current | 5 A | 4 A |
| Utilisation category of auxiliary contacts | | |
| AC15 at | 230 V | 230 V |
| Max. current | 5 A | 3 A |
| DC13 (6 cycles/min) at | 24 V | 24 V |
| Max. current | 5 A | 4 A |
| Utilisation category in accordance with UL | | |
| Voltage | 240 V AC G.U. (same polarity) | 240 V AC G.U. (same polarity) |
| With current | 6 A | 6 A |
| Voltage | 24 V DC G. U. | 24 V DC G. U. |
| With current | 6 A | 6 A |
| External contact fuse protection, safety contacts | | |
| In accordance with the standard | EN 60947-5-1 | EN 60947-5-1 |
| Max. melting integral | 260 A²s | 66 A²s |
| Blow-out fuse, quick | 10 A | 6 A |
| Blow-out fuse, slow | 6 A | 4 A |
| Blow-out fuse, gG | 10 A | 6 A |
| Circuit breaker 24V AC/DC, characteristic B/C | 6 A | 4 A |
| External contact fuse protection, auxiliary contacts | | |
| Max. melting integral | 160 A²s | 66 A²s |
| Blow-out fuse, quick | 10 A | 6 A |
| Blow-out fuse, slow | 6 A | 4 A |
| Blow-out fuse, gG | 6 A | 6 A |
| Circuit breaker 24 V AC/DC, characteristic B/C | 6 A | 4 A |
| Contact material | AgCuNi + 0,2 µm Au | AgCuNi + 0,2 µm Au |

Safety relays PNOZsigma PNOZ s6

| Conventional thermal current while loading several contacts | 751106 | 751136 |
|--|---|---|
| Ith per contact at UB AC; AC1: 240 V, DC1: 24 V | | |
| Conv. therm. current with 1 contact | – | 6 A |
| Conv. therm. current with 2 contacts | – | 6 A |
| Conv. therm. current with 3 contacts | – | 4,5 A |
| Ith per contact at UB DC; AC1: 240 V, DC1: 24 V | | |
| Conv. therm. current with 1 contact | 6 A | 6 A |
| Conv. therm. current with 2 contacts | 6 A | 6 A |
| Conv. therm. current with 3 contacts | 6 A | 4,5 A |
| Times | 751106 | 751136 |
| Delay-on de-energisation (response time in accordance with EN 574) | | |
| Normally open contact | 30 ms | 30 ms |
| N/C | 40 ms | 40 ms |
| Recovery time | 250 ms | 250 ms |
| Supply interruption before de-energisation | 20 ms | 20 ms |
| Simultaneity, channel 1 and 2 max. | 0,5 s | 0,5 s |
| Environmental data | 751106 | 751136 |
| Climatic suitability | EN 60068-2-78 | EN 60068-2-78 |
| Ambient temperature | | |
| Temperature range | -10 - 55 °C | -10 - 55 °C |
| Storage temperature | | |
| Temperature range | -40 - 85 °C | -40 - 85 °C |
| Climatic suitability | | |
| Humidity | 93 % r. h. at 40 °C | 93 % r. h. at 40 °C |
| Condensation during operation | Not permitted | Not permitted |
| EMC | EN 60947-5-1, EN 61000-6-2, EN 61000-6-4, EN 61326-3-1 | EN 60947-5-1, EN 61000-6-2, EN 61000-6-4, EN 61326-3-1 |
| Vibration | | |
| In accordance with the standard | EN 60068-2-6 | EN 60068-2-6 |
| Frequency | 10 - 55 Hz | 10 - 55 Hz |
| Amplitude | 0,35 mm | 0,35 mm |

Safety relays PNOZsigma PNOZ s6

| Environmental data | 751106 | 751136 |
|---|--|--|
| Airgap creepage | | |
| In accordance with the standard | EN 60947-1 | EN 60947-1 |
| Overvoltage category | III / II | III / II |
| Pollution degree | 2 | 2 |
| Rated insulation voltage | 250 V | 250 V |
| Rated impulse withstand voltage | 4 kV | 4 kV |
| Protection type | | |
| Mounting area (e.g. control cabinet) | IP54 | IP54 |
| Housing | IP40 | IP40 |
| Terminals | IP20 | IP20 |
| Mechanical data | 751106 | 751136 |
| Mounting position | Any | Any |
| Mechanical life | 10,000,000 cycles | 10,000,000 cycles |
| Material | | |
| Bottom | PC | PC |
| Front | PC | PC |
| Top | PC | PC |
| Connection type | Spring-loaded terminal | Spring-loaded terminal |
| Mounting type | plug-in | plug-in |
| Conductor cross section with spring-loaded terminals: Flexible with/without crimp connector | 0,2 - 2,5 mm², 24 - 12 AWG | 0,2 - 2,5 mm², 24 - 12 AWG |
| Spring-loaded terminals: Terminal points per connection | 2 | 2 |
| Stripping length with spring-loaded terminals | 9 mm | 9 mm |
| Dimensions | | |
| Height | 100 mm | 100 mm |
| Width | 22,5 mm | 22,5 mm |
| Depth | 120 mm | 120 mm |
| Weight | 185 g | 205 g |

Where standards are undated, the 2014-07 latest editions shall apply.

Safety relays PNOZsigma PNOZ s6

Safety characteristic data

| Operating Mode | EN ISO 13849-1: 2015 PL | EN ISO 13849-1: 2015 Category | EN 62061 SIL CL | EN 62061 PFH _D [1/h] | IEC 61511 SIL | IEC 61511 PFD | EN ISO 13849-1: 2015 T _M [year] |
|-------------------|----------------------------|----------------------------------|--------------------|------------------------------------|------------------|------------------|---|
| Two-hand function | PL e | Cat. 4 | SIL CL 3 | 2,62E-09 | SIL 3 | 3,32E-05 | 20 |

All the units used within a safety function must be considered when calculating the safety characteristic data.

Supplementary data

The PFH value depends on the switching frequency and the load on the relay output. If the service life graphs are not accessible, the stated PFH value can be used irrespective of the switching frequency and the load, as the PFH value already considers the relay's B10d value as well as the failure rates of the other components.

Safety relays PNOZsigma PNOZ s6

Service life graph

The service life graphs indicate the number of cycles from which failures due to wear must be expected. The wear is mainly caused by the electrical load; the mechanical load is negligible.

Unit types with U_B 240 VDC

- ▶ U_B : 24 VDC; Order no. 750106, 751106

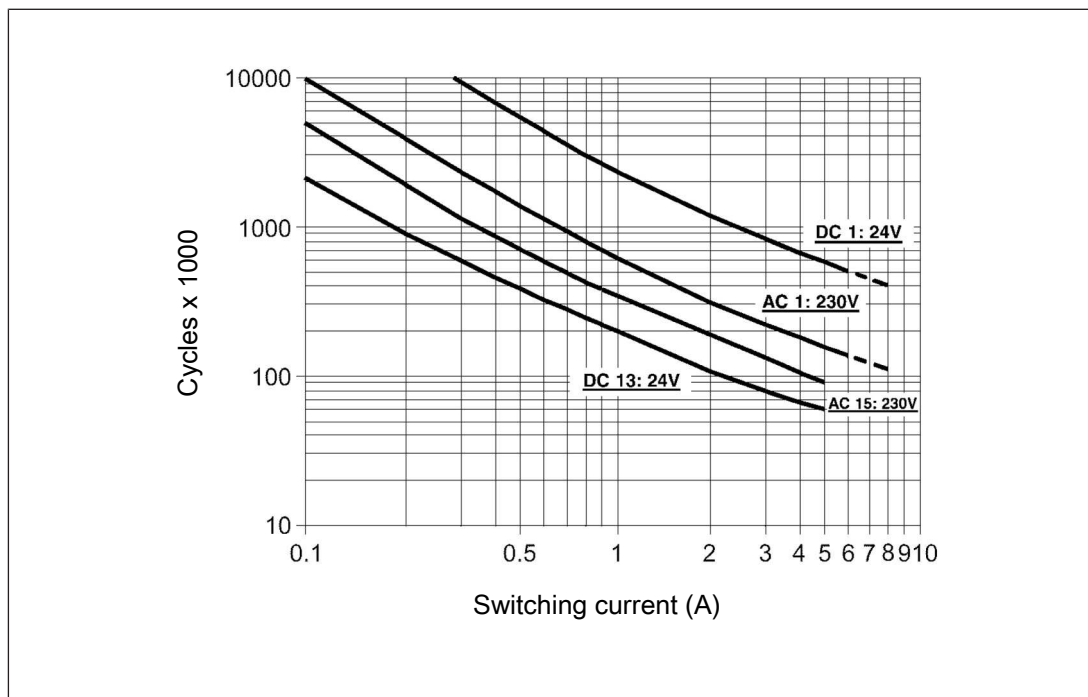

Fig.: Service life graphs at 24 VDC and 230 VAC

Safety relays PNOZsigma PNOZ s6

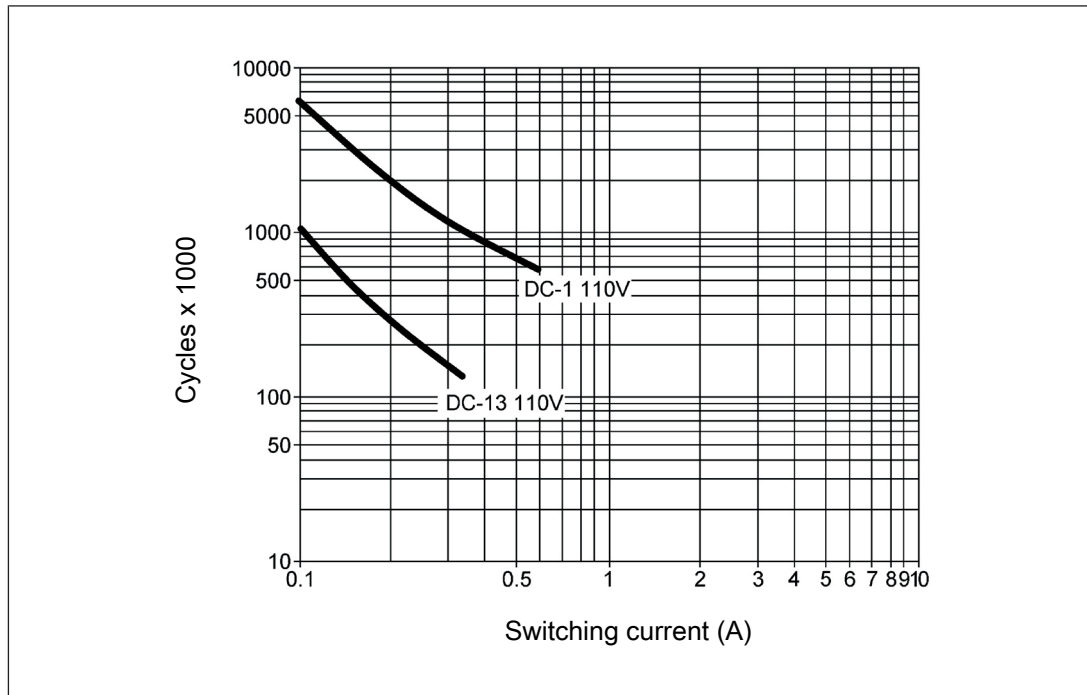

Fig.: Service life graphs at 110 VDC

Example

- ▶ Inductive load: 0.2 A
- ▶ Utilisation category: AC15
- ▶ Contact service life: 2 000 000 cycles

Provided the application to be implemented requires fewer than 2 000 000 cycles, the PFH value (see [Technical details \[667\]](#)) can be used in the calculation.

To increase the service life, sufficient spark suppression must be provided on all output contacts. With capacitive loads, any power surges that occur must be noted. With DC contactors, use flywheel diodes for spark suppression.

Safety relays PNOZsigma PNOZ s6

Unit types with U_B 48 – 240 VAC/DC

▶ U_B : 48 – 240 VAC/DC; Order no. 750136, 751136

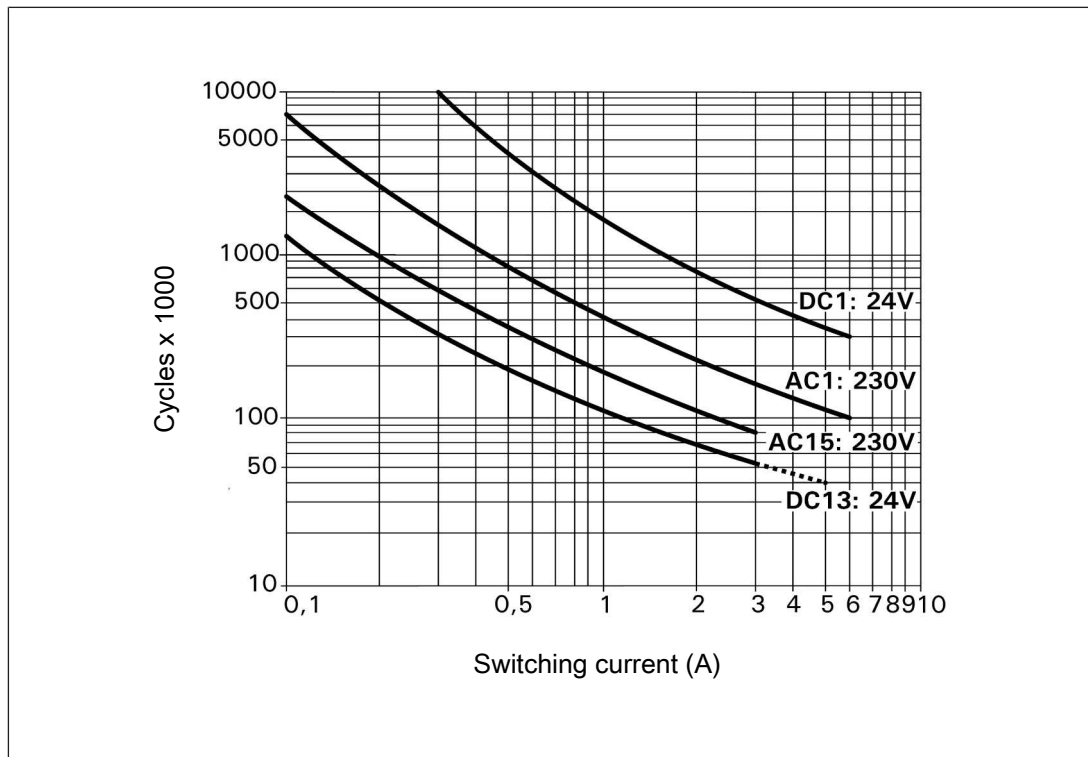

Fig.: Service life graphs at 24 VDC and 230 VAC

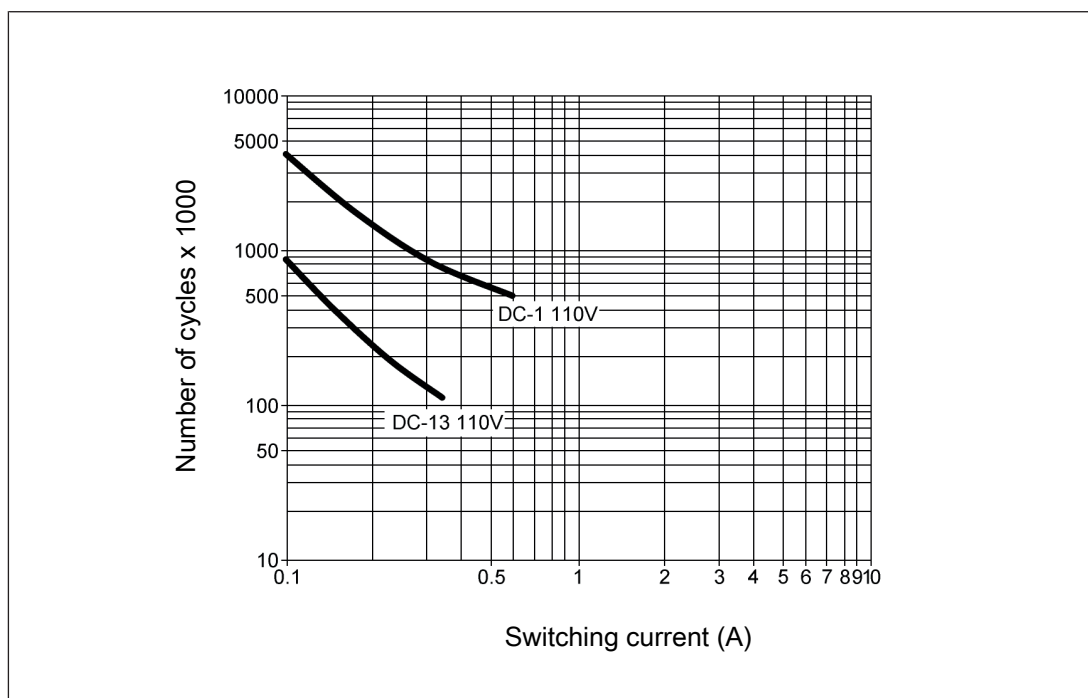

Fig.: Service life graphs at 110 VDC

Safety relays PNOZsigma PNOZ s6

Example

- ▶ Inductive load: 0.2 A
- ▶ Utilisation category: AC15
- ▶ Contact service life: 1 000 000 cycles

Provided the application to be implemented requires fewer than 1 000 000 cycles, the PFH value (see [Technical details \[667\]](#)) can be used in the calculation.

To increase the service life, sufficient spark suppression must be provided on all relay contacts. With capacitive loads, any power surges that occur must be noted. With DC contactors, use flywheel diodes for spark suppression.

Order reference

| Product type | Features | Connection type | Order No. |
|--------------|-----------------|-------------------------|-----------|
| PNOZ s6 | 24 VDC | Screw terminals | 750 106 |
| PNOZ s6 C | 24 VDC | Spring-loaded terminals | 751 106 |
| PNOZ s6 | 48 - 240 VAC/DC | Screw terminals | 750 136 |
| PNOZ s6 C | 48 - 240 VAC/DC | Spring-loaded terminals | 751 136 |

Safety relays PNOZsigma PNOZ s6.1



Unit features

- ▶ Positive-guided relay outputs:
 - 3 safety contacts (N/O), instantaneous
 - 1 auxiliary contact (N/C), instantaneous
- ▶ 1 semiconductor output
- ▶ Connection options for:
 - 2 control elements (pushbuttons)
 - Emergency stop pushbutton
 - Safety gate limit switches
- ▶ A connector can be used to connect 1 PNOZsigma contact expansion module
- ▶ LED for:
 - Supply voltage
 - Input status, channel 1
 - Input status, channel 2
 - Switch status of the safety contacts
 - Feedback loop
 - Fault
- ▶ Plug-in connection terminals (either spring-loaded terminal or screw terminal)
- ▶ See order reference for unit types

Safety relays PNOZsigma PNOZ s6.1

Block diagram/terminal configuration

Unit types with UB 24 VDC

- ▶ U_B : 24 VDC; Order no. 750126, 751126

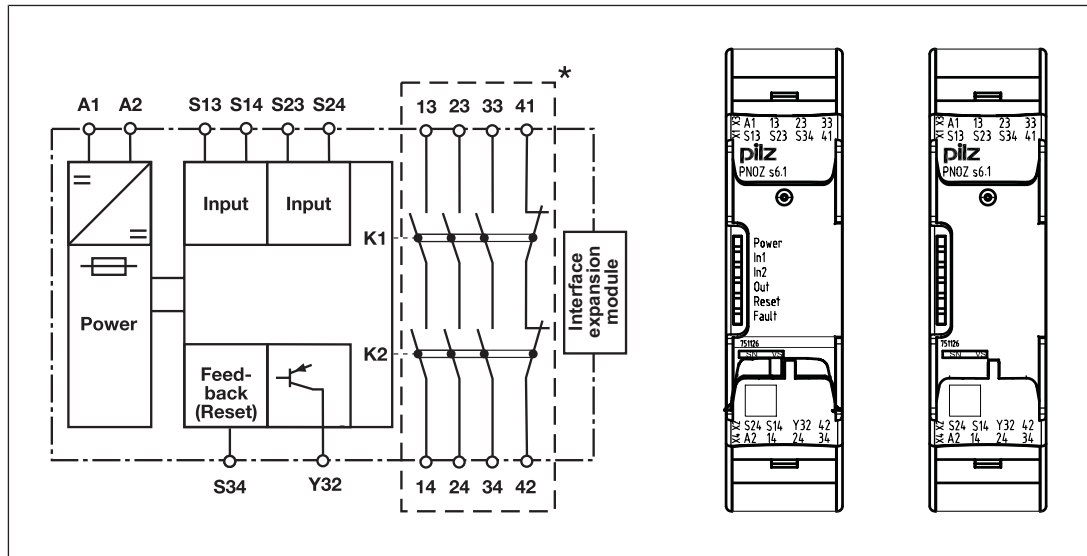

Fig.: Centre: Front view with cover, right: Front view without cover

*Insulation between the non-marked area and the relay contacts: Basic insulation (over-voltage category III), Protective separation (overvoltage category II)

Safety relays PNOZsigma PNOZ s6.1

Unit types with UB 48 - 240 VAC/DC

- ▶ U_B : 48 - 240 VAC/DC; Order no. 750156, 751156

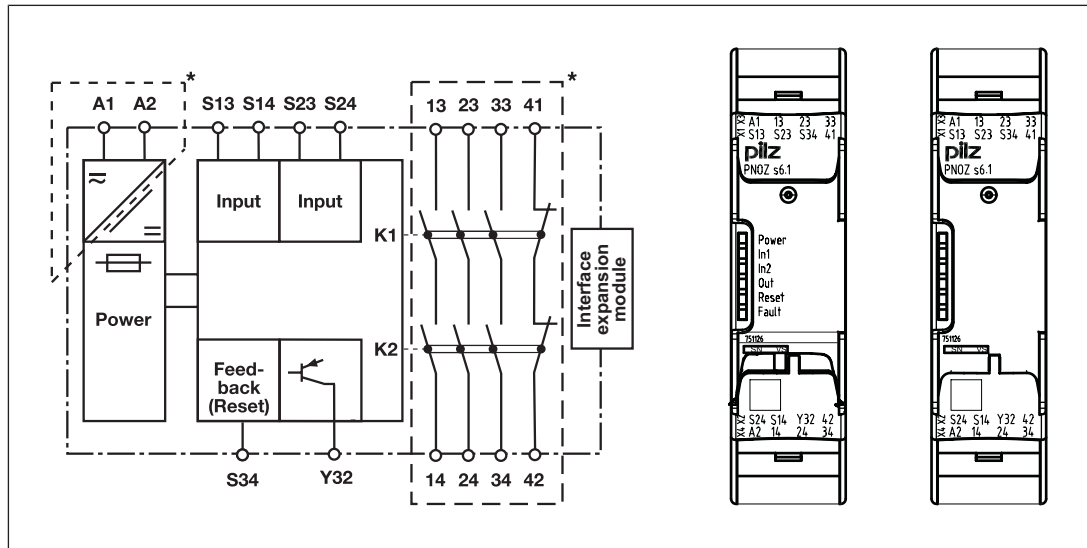

Fig.: Centre: Front view with cover, right: Front view without cover

*Insulation between the non-marked area and the relay contacts: Basic insulation (over-voltage category III), Protective separation (overvoltage category II)

Function description

- ▶ The safety relay must be activated by simultaneously pressing two control elements (pushbuttons) within 0,5 s . If one or both pushbuttons are released or the contacts open, the unit interrupts the control command for the hazardous movement.
- ▶ Reactivation: The output relays will not re-energise until both control elements have been released and re-operated simultaneously or the contacts have opened and then closed.

Safety relays PNOZsigma PNOZ s6.1

Timing diagram

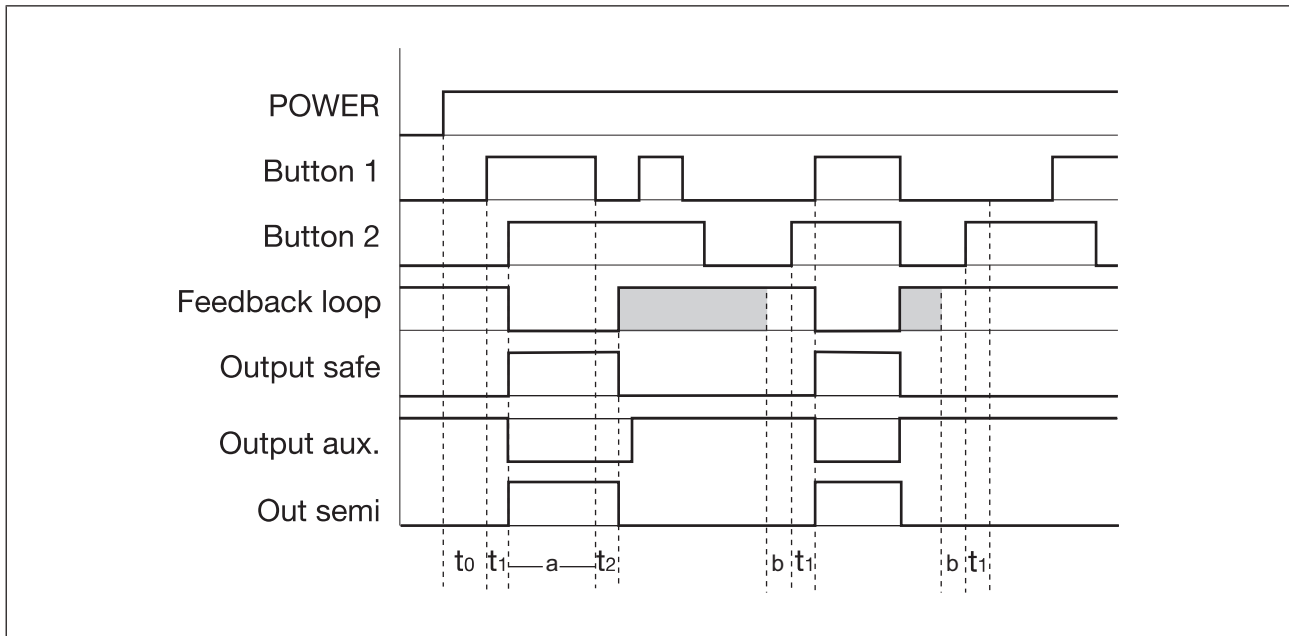

Legend

- ▶ POWER: Supply voltage
- ▶ Button 1/Button 2: Input circuits
- ▶ Feedback loop: Feedback loop
- ▶ Output safe: Safety outputs
- ▶ Output aux.: Auxiliary contacts
- ▶ Out semi: Semiconductor output switch status
- ▶ t_0 : Recovery time after power on
- ▶ t_1 : Simultaneity, channel 1 and 2
- ▶ t_2 : Delay-on de-energisation
- ▶ a : Operating cycle ended through button 1 or 2
- ▶ b : S34-S12 must be closed before before the button is operated

Shaded area: Status irrelevant

Safety relays PNOZsigma PNOZ s6.1

Installation

Install base unit without contact expansion module:

- ▶ Ensure that the plug terminator is inserted at the side of the unit.

Connect base unit and PNOZsigma contact expansion module:

- ▶ Remove the plug terminator at the side of the base unit and at the contact expansion module.
- ▶ Connect the base unit and the contact expansion module to the supplied connector before mounting the units to the DIN rail.

Installation in control cabinet

- ▶ The safety relay should be installed in a control cabinet with a protection type of at least IP54.
- ▶ Use the notch on the rear of the unit to attach it to a DIN rail (35 mm).
- ▶ When installed vertically: Secure the unit by using a fixing element (e.g. retaining bracket or end angle).
- ▶ Push the device upwards or downwards before lifting it from the DIN rail.

Wiring

Please note:

- ▶ Information given in the "[Technical details \[688\]](#)" must be followed.
- ▶ Outputs 13-14, 23-24, 33-34 are safety contacts; output 41-42 is an auxiliary contact (e.g. for display).
- ▶ Auxiliary contact 41-42 and semiconductor output Y32 should **not** be used for safety circuits!
- ▶ To prevent contact welding, a fuse should be connected before the output contacts (see [Technical details \[688\]](#)).
- ▶ Calculation of the max. cable length l_{\max} in the input circuit:

$$l_{\max} = \frac{R_{l\max}}{R_l / \text{km}}$$

$R_{l\max}$ = max. overall cable resistance (see [Technical details \[688\]](#))

R_l / km = cable resistance/km

- ▶ Use copper wire that can withstand 60/75 °C.
- ▶ Sufficient fuse protection must be provided on all output contacts with capacitive and inductive loads.
- ▶ With U_B 48 – 240 VAC/DC: Connect S14 to functional earth.
- ▶ Ensure the wiring and EMC requirements of IEC 60204-1 are met.
- ▶ On 24 VDC devices:
The power supply must comply with the regulations for extra low voltages with protective electrical separation (SELV, PELV) in accordance with VDE 0100, Part 410.

Safety relays PNOZsigma PNOZ s6.1

Preparing for operation

| Supply voltage | Unit types with U_B 48-240 VAC/DC | Unit types with U_B 240 VDC |
|--|-------------------------------------|----------------------------------|
| | | |
| Input circuit | Single-channel | Dual-channel |
| Two-hand button with detection of shorts across contacts | | |
| Simultaneity monitoring in safety gate applications with automatic start after the safety gate is closed | | |
| Feedback loop | with feedback loop monitoring | without feedback loop monitoring |
| Link or contacts from external contactors | | |
| Semiconductor output | | |
| | | |

Legend

- ▶ S1/S2: Two-hand pushbuttons

Safety relays PNOZsigma PNOZ s6.1

Dimensions in mm

*with spring-loaded terminals

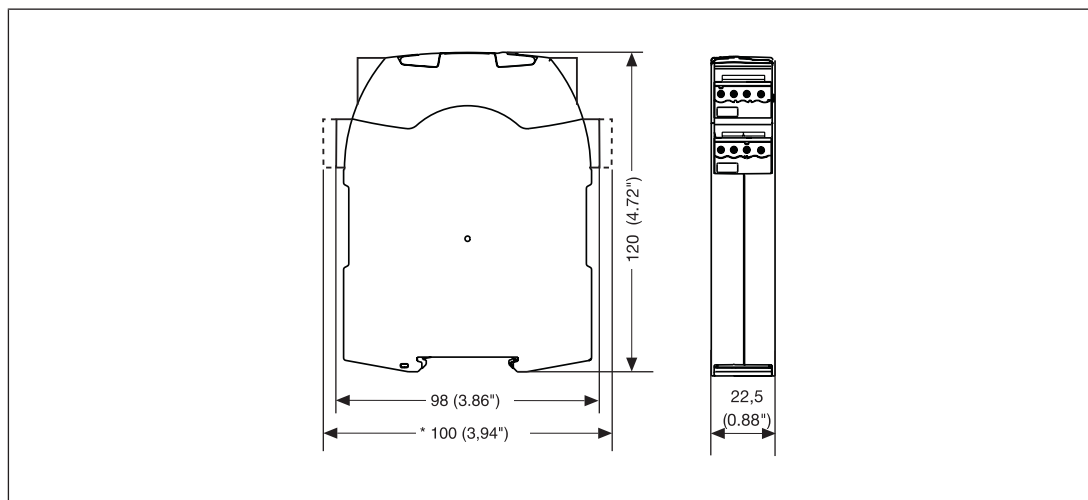

Technical details

Order no. 750123 – 750156

See below for more order numbers

| General | 750126 | 750156 |
|--|--|--|
| Approvals | CCC, CE, EAC (Eurasian), KOSHA, TÜV, cULus Listed | CCC, CE, EAC (Eurasian), KOSHA, TÜV, cULus Listed |
| Electrical data | 750126 | 750156 |
| Supply voltage | | |
| Voltage | 24 V | 48 - 240 V |
| Kind | DC | AC/DC |
| Voltage tolerance | -15 %/+10 % | -15 %/+10 % |
| Output of external power supply (AC) | – | 7 VA |
| Output of external power supply (DC) | 3,5 W | 3,5 W |
| Frequency range AC | – | 50 - 60 Hz |
| Residual ripple DC | 20 % | 20 % |
| Duty cycle | 100 % | 100 % |
| Current at | | |
| Normally open contact | 20 mA | 20 mA |
| Max. overall cable resistance RI-max per input circuit | 30 Ohm | 30 Ohm |
| External unit fuse protection F1 min. | 1 A | 1 A |

Safety relays PNOZsigma PNOZ s6.1

| Electrical data | 750126 | 750156 |
|---|-------------------------------------|-------------------------------------|
| External unit fuse protection F1 max. | Max. conductor cross section | Max. conductor cross section |
| Two-hand control relay type | | |
| In accordance with the standard | EN 574 | EN 574 |
| Type | III A | III A |
| Inputs | 750126 | 750156 |
| Number | 2 | 2 |
| Voltage at | | |
| Input circuit DC | 24 V | 24 V |
| Feedback loop DC | 24 V | 24 V |
| Current at | | |
| Feedback loop DC | 15 mA | 15 mA |
| Semiconductor outputs | 750126 | 750156 |
| Number | 1 | 1 |
| Voltage | 24 V | 24 V |
| Current | 20 mA | 20 mA |
| Relay outputs | 750126 | 750156 |
| Number of output contacts | | |
| Safety contacts (N/O), instantaneous | 3 | 3 |
| Auxiliary contacts (N/C) | 1 | 1 |
| Max. short circuit current I _K | 1 kA | 1 kA |
| Utilisation category | | |
| In accordance with the standard | EN 60947-4-1 | EN 60947-4-1 |
| Utilisation category of safety contacts | | |
| AC1 at | 240 V | 240 V |
| Min. current | 0,01 A | 0,01 A |
| Max. current | 6 A | 6 A |
| Max. power | 1500 VA | 1500 VA |
| DC1 at | 24 V | 24 V |
| Min. current | 0,01 A | 0,01 A |
| Max. current | 6 A | 6 A |
| Max. power | 150 W | 150 W |

Safety relays PNOZsigma PNOZ s6.1

| Relay outputs | 750126 | 750156 |
|---|-------------------------------|-------------------------------|
| Utilisation category of auxiliary contacts | | |
| AC1 at | 240 V | 240 V |
| Min. current | 0,01 A | 0,01 A |
| Max. current | 6 A | 6 A |
| Max. power | 1500 VA | 1500 VA |
| DC1 at | 24 V | 24 V |
| Min. current | 0,01 A | 0,01 A |
| Max. current | 6 A | 6 A |
| Max. power | 150 W | 150 W |
| Utilisation category | | |
| In accordance with the standard | EN 60947-5-1 | EN 60947-5-1 |
| Utilisation category of safety contacts | | |
| AC15 at | 230 V | 230 V |
| Max. current | 5 A | 3 A |
| DC13 (6 cycles/min) at | 24 V | 24 V |
| Max. current | 5 A | 4 A |
| Utilisation category of auxiliary contacts | | |
| AC15 at | 230 V | 230 V |
| Max. current | 5 A | 3 A |
| DC13 (6 cycles/min) at | 24 V | 24 V |
| Max. current | 5 A | 4 A |
| Utilisation category in accordance with UL | | |
| Voltage | 240 V AC G.U. (same polarity) | 240 V AC G.U. (same polarity) |
| With current | 6 A | 6 A |
| Voltage | 24 V DC G. U. | 24 V DC G. U. |
| With current | 6 A | 6 A |
| External contact fuse protection, safety contacts | | |
| In accordance with the standard | EN 60947-5-1 | EN 60947-5-1 |
| Max. melting integral | 260 A ² s | 66 A ² s |
| Blow-out fuse, quick | 10 A | 6 A |
| Blow-out fuse, slow | 6 A | 4 A |
| Blow-out fuse, gG | 10 A | 6 A |
| Circuit breaker 24V AC/DC, characteristic B/C | 6 A | 4 A |

Safety relays PNOZsigma PNOZ s6.1

| Relay outputs | 750126 | 750156 |
|--|----------------------|---------------------|
| External contact fuse protection, auxiliary contacts | | |
| Max. melting integral | 160 A ² s | 66 A ² s |
| Blow-out fuse, quick | 10 A | 6 A |
| Blow-out fuse, slow | 6 A | 4 A |
| Blow-out fuse, gG | 6 A | 6 A |
| Circuit breaker 24 V AC/DC, characteristic B/C | 6 A | 4 A |
| Contact material | AgCuNi + 0,2 µm Au | AgCuNi + 0,2 µm Au |
| Conventional thermal current while loading several contacts | 750126 | 750156 |
| I _{th} per contact at UB AC; AC1: 240 V, DC1: 24 V | | |
| Conv. therm. current with 1 contact | – | 6 A |
| Conv. therm. current with 2 contacts | – | 6 A |
| Conv. therm. current with 3 contacts | – | 4,5 A |
| I _{th} per contact at UB DC; AC1: 240 V, DC1: 24 V | | |
| Conv. therm. current with 1 contact | 6 A | 6 A |
| Conv. therm. current with 2 contacts | 6 A | 6 A |
| Conv. therm. current with 3 contacts | 6 A | 4,5 A |
| Times | 750126 | 750156 |
| Delay-on de-energisation (response time in accordance with EN 574) | | |
| Normally open contact | 40 ms | 40 ms |
| N/C | 50 ms | 50 ms |
| Recovery time | 250 ms | 250 ms |
| Supply interruption before de-energisation | 20 ms | 20 ms |
| Simultaneity, channel 1 and 2 max. | 0,5 s | 0,5 s |
| Environmental data | 750126 | 750156 |
| Climatic suitability | EN 60068-2-78 | EN 60068-2-78 |
| Ambient temperature | | |
| Temperature range | -10 - 55 °C | -10 - 55 °C |
| Storage temperature | | |
| Temperature range | -40 - 85 °C | -40 - 85 °C |

Safety relays PNOZsigma PNOZ s6.1

| Environmental data | 750126 | 750156 |
|---|--|--|
| Climatic suitability | | |
| Humidity | 93 % r. h. at 40 °C | 93 % r. h. at 40 °C |
| Condensation during operation | Not permitted | Not permitted |
| EMC | EN 60947-5-1, EN 61000-6-2, EN 61000-6-4, EN 61326-3-1 | EN 60947-5-1, EN 61000-6-2, EN 61000-6-4, EN 61326-3-1 |
| Vibration | | |
| In accordance with the standard | EN 60068-2-6 | EN 60068-2-6 |
| Frequency | 10 - 55 Hz | 10 - 55 Hz |
| Amplitude | 0,35 mm | 0,35 mm |
| Airgap creepage | | |
| In accordance with the standard | EN 60947-1 | EN 60947-1 |
| Overvoltage category | III / II | III / II |
| Pollution degree | 2 | 2 |
| Rated insulation voltage | 250 V | 250 V |
| Rated impulse withstand voltage | 4 kV | 4 kV |
| Protection type | | |
| Mounting area (e.g. control cabinet) | IP54 | IP54 |
| Housing | IP40 | IP40 |
| Terminals | IP20 | IP20 |
| Mechanical data | 750126 | 750156 |
| Mounting position | Any | Any |
| Mechanical life | 10,000,000 cycles | 10,000,000 cycles |
| Material | | |
| Bottom | PC | PC |
| Front | PC | PC |
| Top | PC | PC |
| Connection type | Screw terminal | Screw terminal |
| Mounting type | plug-in | plug-in |
| Conductor cross section with screw terminals | | |
| 1 core flexible | 0,25 - 2,5 mm ² , 24 - 12 AWG | 0,25 - 2,5 mm ² , 24 - 12 AWG |
| 2 core with the same cross section, flexible with crimp connectors, no plastic sleeve | 0,25 - 1 mm ² , 24 - 16 AWG | 0,25 - 1 mm ² , 24 - 16 AWG |
| 2 core with the same cross section, flexible without crimp connectors or with TWIN crimp connectors | 0,2 - 1,5 mm ² , 24 - 16 AWG | 0,2 - 1,5 mm ² , 24 - 16 AWG |
| Torque setting with screw terminals | 0,5 Nm | 0,5 Nm |

Safety relays PNOZsigma PNOZ s6.1

| Mechanical data | 750126 | 750156 |
|-----------------|---------|---------|
| Dimensions | | |
| Height | 98 mm | 98 mm |
| Width | 22,5 mm | 22,5 mm |
| Depth | 120 mm | 120 mm |
| Weight | 185 g | 205 g |

Where standards are undated, the 2014-07 latest editions shall apply.

Order no. 751126 – 751156

| General | 751126 | 751156 |
|--|--|--|
| Approvals | CCC, CE, EAC (Eurasian), KOSHA, TÜV, cULus Listed | CCC, CE, EAC (Eurasian), KOSHA, TÜV, cULus Listed |
| Electrical data | 751126 | 751156 |
| Supply voltage | | |
| Voltage | 24 V | 48 - 240 V |
| Kind | DC | AC/DC |
| Voltage tolerance | -15 %/+10 % | -15 %/+10 % |
| Output of external power supply (AC) | – | 7 VA |
| Output of external power supply (DC) | 3,5 W | 3,5 W |
| Frequency range AC | – | 50 - 60 Hz |
| Residual ripple DC | 20 % | 20 % |
| Duty cycle | 100 % | 100 % |
| Current at | | |
| Normally open contact | 20 mA | 20 mA |
| Max. overall cable resistance RI- max per input circuit | 30 Ohm | 30 Ohm |
| External unit fuse protection F1 min. | 1 A | 1 A |
| External unit fuse protection F1 max. | Max. conductor cross section | Max. conductor cross section |
| Two-hand control relay type | | |
| In accordance with the standard | EN 574 | EN 574 |
| Type | III A | III A |
| Inputs | 751126 | 751156 |
| Number | 2 | 2 |
| Voltage at | | |
| Input circuit DC | 24 V | 24 V |
| Feedback loop DC | 24 V | 24 V |

Safety relays PNOZsigma PNOZ s6.1

| Inputs | 751126 | 751156 |
|--|---------------------|---------------------|
| Current at | | |
| Feedback loop DC | 15 mA | 15 mA |
| Semiconductor outputs | 751126 | 751156 |
| Number | 1 | 1 |
| Voltage | 24 V | 24 V |
| Current | 20 mA | 20 mA |
| Relay outputs | 751126 | 751156 |
| Number of output contacts | | |
| Safety contacts (N/O), instantaneous | 3 | 3 |
| Auxiliary contacts (N/C) | 1 | 1 |
| Max. short circuit current I _K | 1 kA | 1 kA |
| Utilisation category | | |
| In accordance with the standard | EN 60947-4-1 | EN 60947-4-1 |
| Utilisation category of safety contacts | | |
| AC1 at | 240 V | 240 V |
| Min. current | 0,01 A | 0,01 A |
| Max. current | 6 A | 6 A |
| Max. power | 1500 VA | 1500 VA |
| DC1 at | 24 V | 24 V |
| Min. current | 0,01 A | 0,01 A |
| Max. current | 6 A | 6 A |
| Max. power | 150 W | 150 W |
| Utilisation category of auxiliary contacts | | |
| AC1 at | 240 V | 240 V |
| Min. current | 0,01 A | 0,01 A |
| Max. current | 6 A | 6 A |
| Max. power | 1500 VA | 1500 VA |
| DC1 at | 24 V | 24 V |
| Min. current | 0,01 A | 0,01 A |
| Max. current | 6 A | 6 A |
| Max. power | 150 W | 150 W |
| Utilisation category | | |
| In accordance with the standard | EN 60947-5-1 | EN 60947-5-1 |
| Utilisation category of safety contacts | | |
| AC15 at | 230 V | 230 V |
| Max. current | 5 A | 3 A |
| DC13 (6 cycles/min) at | 24 V | 24 V |
| Max. current | 5 A | 4 A |

Safety relays PNOZsigma PNOZ s6.1

| Relay outputs | 751126 | 751156 |
|--|-------------------------------|-------------------------------|
| Utilisation category of auxiliary contacts | | |
| AC15 at | 230 V | 230 V |
| Max. current | 5 A | 3 A |
| DC13 (6 cycles/min) at | 24 V | 24 V |
| Max. current | 5 A | 4 A |
| Utilisation category in accordance with UL | | |
| Voltage | 240 V AC G.U. (same polarity) | 240 V AC G.U. (same polarity) |
| With current | 6 A | 6 A |
| Voltage | 24 V DC G. U. | 24 V DC G. U. |
| With current | 6 A | 6 A |
| External contact fuse protection, safety contacts | | |
| In accordance with the standard | EN 60947-5-1 | EN 60947-5-1 |
| Max. melting integral | 260 A ² s | 66 A ² s |
| Blow-out fuse, quick | 10 A | 6 A |
| Blow-out fuse, slow | 6 A | 4 A |
| Blow-out fuse, gG | 10 A | 6 A |
| Circuit breaker 24V AC/DC, characteristic B/C | 6 A | 4 A |
| External contact fuse protection, auxiliary contacts | | |
| Max. melting integral | 160 A ² s | 66 A ² s |
| Blow-out fuse, quick | 10 A | 6 A |
| Blow-out fuse, slow | 6 A | 4 A |
| Blow-out fuse, gG | 6 A | 6 A |
| Circuit breaker 24 V AC/DC, characteristic B/C | 6 A | 4 A |
| Contact material | AgCuNi + 0,2 µm Au | AgCuNi + 0,2 µm Au |
| Conventional thermal current while loading several contacts | 751126 | 751156 |
| I _{th} per contact at UB AC; AC1: 240 V, DC1: 24 V | | |
| Conv. therm. current with 1 contact | – | 6 A |
| Conv. therm. current with 2 contacts | – | 6 A |
| Conv. therm. current with 3 contacts | – | 4,5 A |

Safety relays PNOZsigma PNOZ s6.1

| Conventional thermal current while loading several contacts | 751126 | 751156 |
|--|---|---|
| Ith per contact at UB DC; AC1: 240 V, DC1: 24 V | | |
| Conv. therm. current with 1 contact | 6 A | 6 A |
| Conv. therm. current with 2 contacts | 6 A | 6 A |
| Conv. therm. current with 3 contacts | 6 A | 4,5 A |
| Times | 751126 | 751156 |
| Delay-on de-energisation (response time in accordance with EN 574) | | |
| Normally open contact | 40 ms | 40 ms |
| N/C | 50 ms | 50 ms |
| Recovery time | 250 ms | 250 ms |
| Supply interruption before de-energisation | 20 ms | 20 ms |
| Simultaneity, channel 1 and 2 max. | 0,5 s | 0,5 s |
| Environmental data | 751126 | 751156 |
| Climatic suitability | EN 60068-2-78 | EN 60068-2-78 |
| Ambient temperature | | |
| Temperature range | -10 - 55 °C | -10 - 55 °C |
| Storage temperature | | |
| Temperature range | -40 - 85 °C | -40 - 85 °C |
| Climatic suitability | | |
| Humidity | 93 % r. h. at 40 °C | 93 % r. h. at 40 °C |
| Condensation during operation | Not permitted | Not permitted |
| EMC | EN 60947-5-1, EN 61000-6-2, EN 61000-6-4, EN 61326-3-1 | EN 60947-5-1, EN 61000-6-2, EN 61000-6-4, EN 61326-3-1 |
| Vibration | | |
| In accordance with the standard | EN 60068-2-6 | EN 60068-2-6 |
| Frequency | 10 - 55 Hz | 10 - 55 Hz |
| Amplitude | 0,35 mm | 0,35 mm |
| Airgap creepage | | |
| In accordance with the standard | EN 60947-1 | EN 60947-1 |
| Overvoltage category | III / II | III / II |
| Pollution degree | 2 | 2 |
| Rated insulation voltage | 250 V | 250 V |
| Rated impulse withstand voltage | 4 kV | 4 kV |

Safety relays PNOZsigma PNOZ s6.1

| Environmental data | 751126 | 751156 |
|---|--|--|
| Protection type | | |
| Mounting area (e.g. control cabinet) | IP54 | IP54 |
| Housing | IP40 | IP40 |
| Terminals | IP20 | IP20 |
| Mechanical data | 751126 | 751156 |
| Mounting position | Any | Any |
| Mechanical life | 10,000,000 cycles | 10,000,000 cycles |
| Material | | |
| Bottom | PC | PC |
| Front | PC | PC |
| Top | PC | PC |
| Connection type | Spring-loaded terminal | Spring-loaded terminal |
| Mounting type | plug-in | plug-in |
| Conductor cross section with spring-loaded terminals: Flexible with/without crimp connector | 0,2 - 2,5 mm², 24 - 12 AWG | 0,2 - 2,5 mm², 24 - 12 AWG |
| Spring-loaded terminals: Terminal points per connection | 2 | 2 |
| Stripping length with spring-loaded terminals | 9 mm | 9 mm |
| Dimensions | | |
| Height | 100 mm | 100 mm |
| Width | 22,5 mm | 22,5 mm |
| Depth | 120 mm | 120 mm |
| Weight | 185 g | 205 g |

Where standards are undated, the 2014-07 latest editions shall apply.

Safety relays PNOZsigma PNOZ s6.1

Safety characteristic data

| Operating Mode | EN ISO 13849-1: 2015 PL | EN ISO 13849-1: 2015 Category | EN 62061 SIL CL | EN 62061 PFH _D [1/h] | IEC 61511 SIL | IEC 61511 PFD | EN ISO 13849-1: 2015 T _M [year] |
|------------------------------------|----------------------------|----------------------------------|--------------------|------------------------------------|------------------|------------------|---|
| E-STOP/ safety gate function | PL e | Cat. 4 | SIL CL 3 | 2,62E-09 | SIL 3 | 3,32E-05 | 20 |
| Two-hand function | PL c | Cat. 1 | SIL CL 1 | 5,99E-08 | SIL 1 | 5,10E-03 | 20 |

All the units used within a safety function must be considered when calculating the safety characteristic data.

Supplementary data

The PFH value depends on the switching frequency and the load on the relay output. If the service life graphs are not accessible, the stated PFH value can be used irrespective of the switching frequency and the load, as the PFH value already considers the relay's B10d value as well as the failure rates of the other components.

Safety relays PNOZsigma PNOZ s6.1

Service life graph

The service life graphs indicate the number of cycles from which failures due to wear must be expected. The wear is mainly caused by the electrical load; the mechanical load is negligible.

Unit types with U_B 240 VDC

- ▶ U_B : 24 VDC; Order no. 750126, 751126

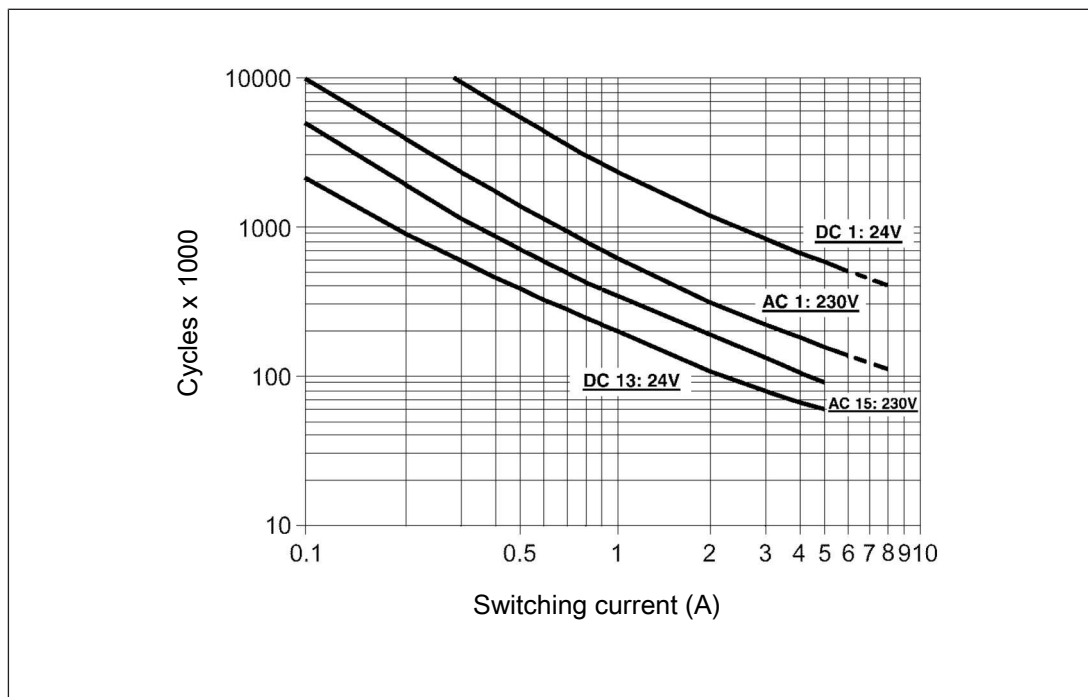

Fig.: Service life graphs at 24 VDC and 230 VAC

Safety relays PNOZsigma PNOZ s6.1

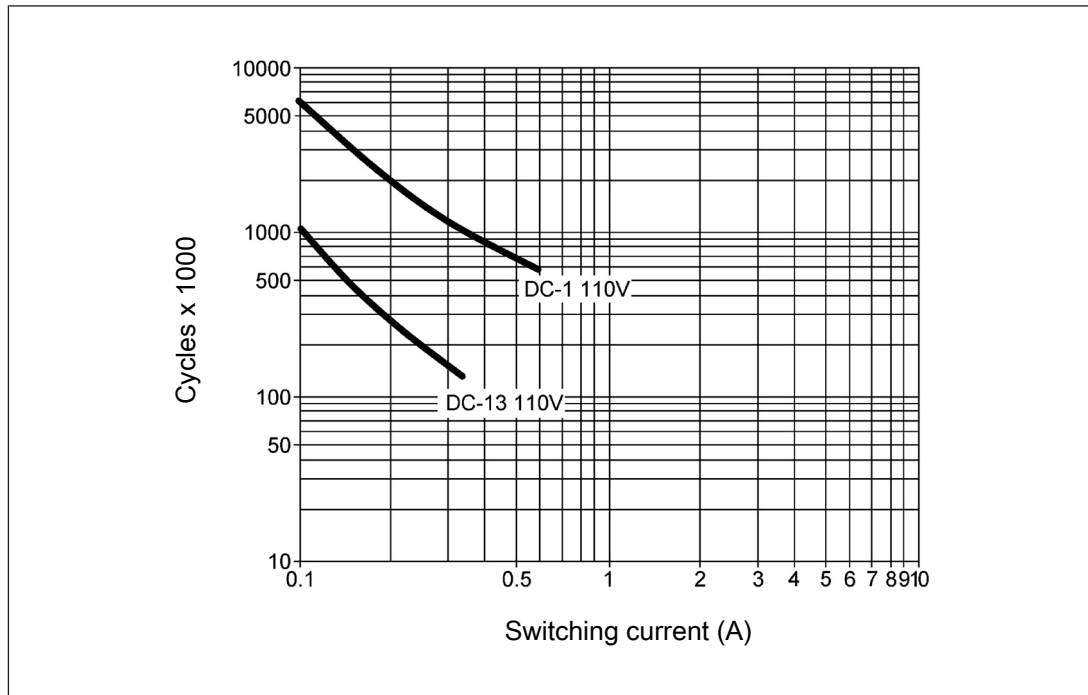

Fig.: Service life graphs at 110 VDC

Example

- ▶ Inductive load: 0.2 A
- ▶ Utilisation category: AC15
- ▶ Contact service life: 2 000 000 cycles

Provided the application to be implemented requires fewer than 2 000 000 cycles, the PFH value (see [Technical details \[688\]](#)) can be used in the calculation.

To increase the service life, sufficient spark suppression must be provided on all output contacts. With capacitive loads, any power surges that occur must be noted. With DC contactors, use flywheel diodes for spark suppression.

Safety relays PNOZsigma PNOZ s6.1

Unit types with U_B 48 – 240 VAC/DC

▶ U_B : 48 – 240 VAC/DC; Order no. 750156, 751156

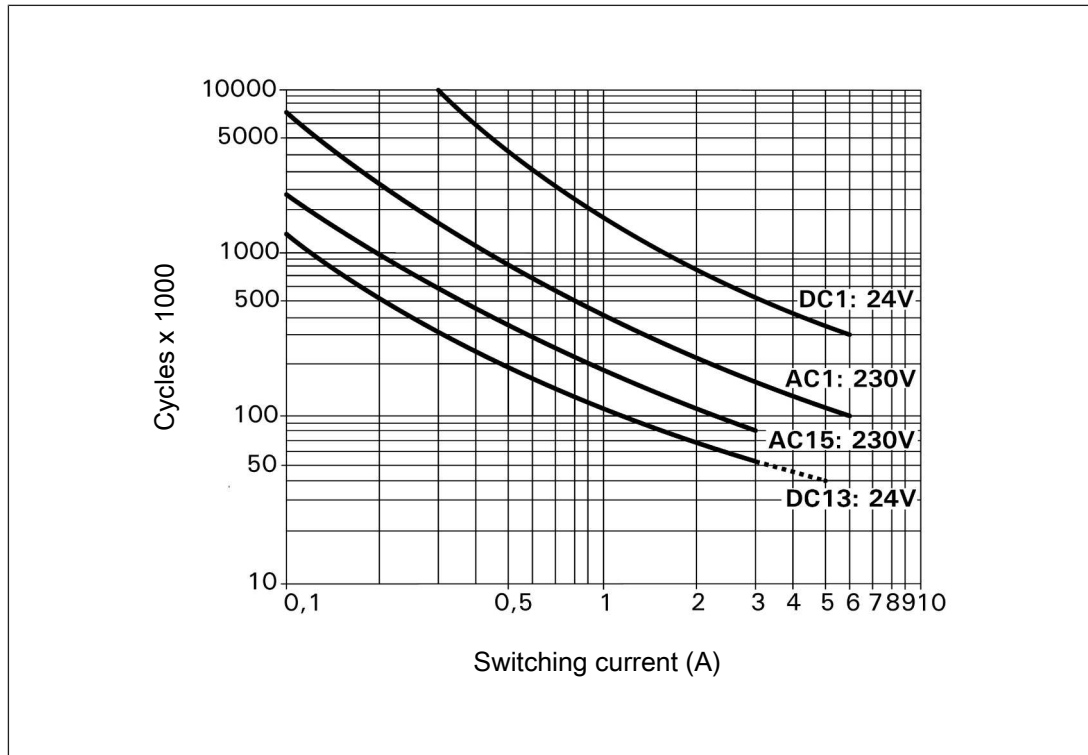

Fig.: Service life graphs at 24 VDC and 230 VAC

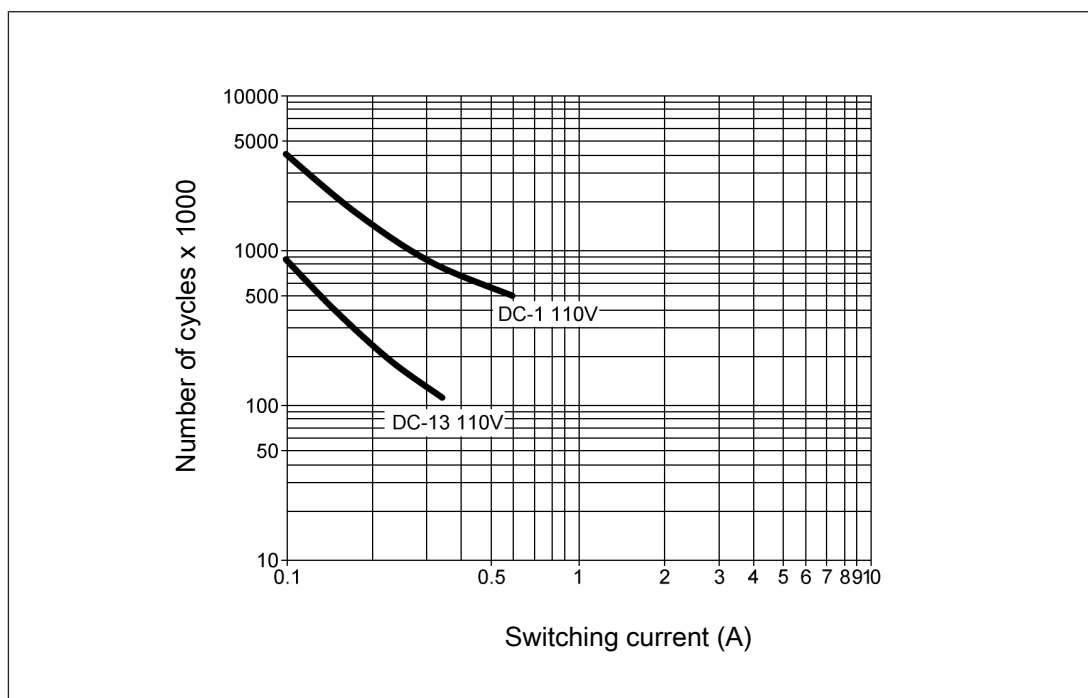

Fig.: Service life graphs at 110 VDC

Safety relays PNOZsigma PNOZ s6.1

Example

- ▶ Inductive load: 0.2 A
- ▶ Utilisation category: AC15
- ▶ Contact service life: 1 000 000 cycles

Provided the application to be implemented requires fewer than 1 000 000 cycles, the PFH value (see [Technical details \[688\]](#)) can be used in the calculation.

To increase the service life, sufficient spark suppression must be provided on all relay contacts. With capacitive loads, any power surges that occur must be noted. With DC contactors, use flywheel diodes for spark suppression.

Order reference

| Product type | Features | Connection type | Order No. |
|--------------|-----------------|-------------------------|-----------|
| PNOZ s6.1 | 24 VDC | Screw terminals | 750 126 |
| PNOZ s6.1 C | 24 VDC | Spring-loaded terminals | 751 126 |
| PNOZ s6.1 | 48 - 240 VAC/DC | Screw terminals | 750 156 |
| PNOZ s6.1 C | 48 - 240 VAC/DC | Spring-loaded terminals | 751 156 |

Safety relays PNOZsigma PNOZ s7

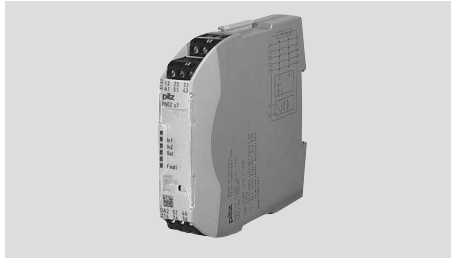

Unit features

- ▶ Positive-guided relay outputs:
 - 4 safety contacts (N/O), instantaneous
 - 1 auxiliary contact (N/C), instantaneous
- ▶ LED for:
 - Input status, channel 1
 - Input status, channel 2
 - Switch status of the safety contacts
 - Fault
- ▶ Plug-in connection terminals (either spring-loaded terminal or screw terminal)
- ▶ See order reference for unit types

Safety relays PNOZsigma PNOZ s7

Block diagram/terminal configuration

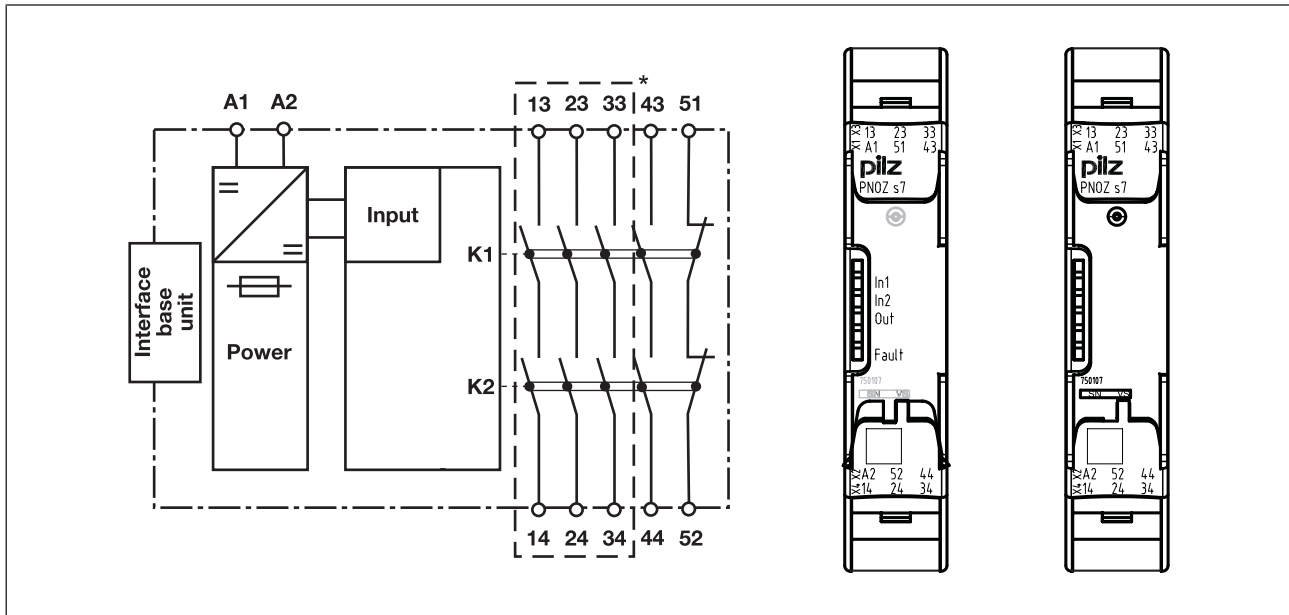

Fig.: Centre: Front view with cover, right: Front view without cover

*Safe separation from non-marked area in accordance with EN 60947-1, 6 kV, basic insulation between all safety contacts.

Function description

with PNOZsigma base unit:

- ▶ Dual-channel operation via PNOZsigma connector

without PNOZsigma base unit:

- ▶ Single-channel operation: one input circuit affects the output relays

Safety relays PNOZsigma PNOZ s7

Timing diagram

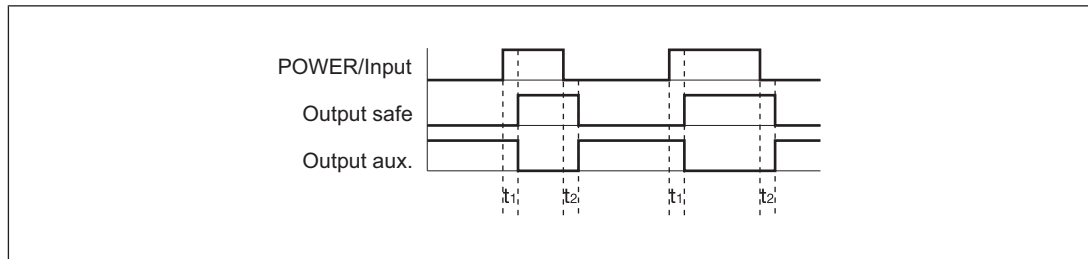

Legend

- ▶ POWER/Input: Supply voltage/input circuit
- ▶ Output safe: Safety contacts
- ▶ Output aux.: Auxiliary contacts
- ▶ t_1 : Switch-on delay
- ▶ t_2 : Delay-on de-energisation

Installation

Install contact expansion module without base unit:

- ▶ Ensure that the plug terminator is inserted at the side of the unit.

Connect base unit and PNOZsigma contact expansion module:

- ▶ Remove the plug terminator at the side of the base unit and at the contact expander module
- ▶ Connect the base unit and the contact expansion module using the connector supplied, before mounting the units to the DIN rail.

Control cabinet installation

- ▶ The safety relay should be installed in a control cabinet with a protection type of at least IP54.
- ▶ Use the notch on the rear of the unit to attach it to a DIN rail (35 mm).
- ▶ When installed vertically: Secure the unit by using a fixing element (e.g. retaining bracket or end angle).
- ▶ Push the unit upwards or downwards before lifting it from the DIN rail.

Safety relays PNOZsigma PNOZ s7

Wiring

Please note:

- ▶ Information given in the "[Technical details \[708\]](#)" must be followed.
- ▶ Outputs 13-14, 23-24, 33-34, 43-44 are safety contacts; outputs 51 -52 are auxiliary contacts (e.g. for display).
- ▶ Auxiliary contact 51-52 should **not** be used for safety circuits!
- ▶ To prevent contact welding, a fuse should be connected before the output contacts (see [Technical details \[708\]](#)).
- ▶ Calculation of the max. cable length l_{max} in the input circuit:

$$l_{max} = \frac{R_{lmax}}{R_i / km}$$

R_{lmax} = max. overall cable resistance (see [Technical details \[708\]](#))

R_i / km = cable resistance/km

- ▶ Use copper wire that can withstand 60/75 °C.
- ▶ Sufficient fuse protection must be provided on all output contacts with capacitive and inductive loads.
- ▶ Ensure the wiring and EMC requirements of IEC 60204-1 are met.
- ▶ The power supply must comply with the regulations for extra low voltages with protective electrical separation (SELV, PELV) in accordance with VDE 0100, Part 410.

Preparing for operation

| Supply voltage | AC | DC |
|---|----------------|--------------|
| | | |
| Input circuit | Single-channel | Dual-channel |
| Base unit: Safety relay PNOZ X | | |
| Base unit: Safety relay PNOZelog Driven via semiconductor outputs (24 VDC) | | |

Safety relays PNOZsigma PNOZ s7

| Feedback loop | Base unit: Safety relay PNOZ X | Base unit: Safety relay PNOZelog |
|---|-----------------------------------|--|
| The inputs that evaluate the feedback loop will depend on the base unit and application | | |
| Connection to PNOZsigma base unit/PNOZmulti Mini base unit | Base unit: Safety relay PNOZsigma | Base unit: Small control system PNOZmulti Mini |
| The feedback loop is connected and evaluated via the connector | | |

Dimensions in mm

*with spring-loaded terminals

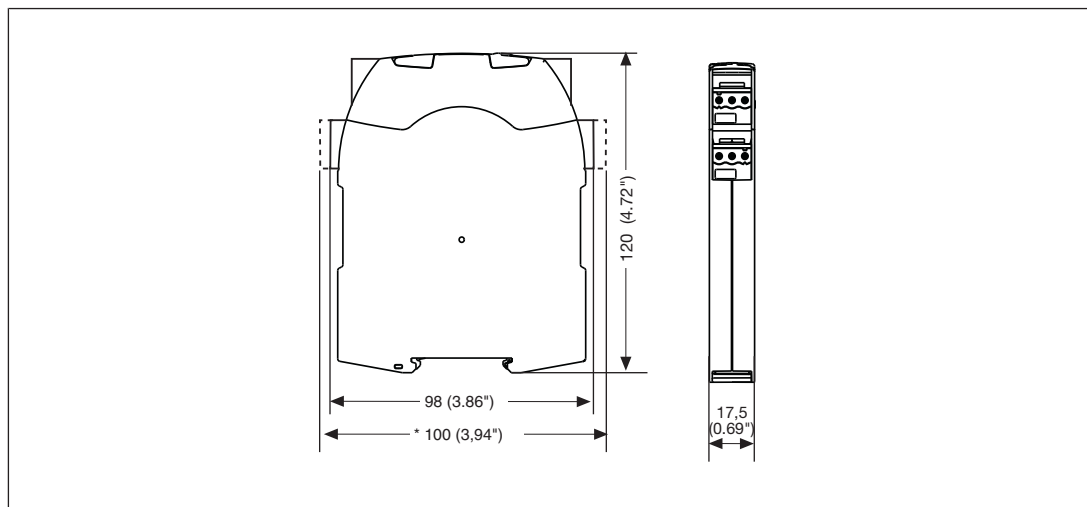

Safety relays PNOZsigma PNOZ s7

Technical details

| General | 750107 | 751107 | 751187 |
|---|---|---|---|
| Approvals | CCC, CE, EAC (Eurasian), KOSHA, TÜV, cULus Listed | CCC, CE, EAC (Eurasian), KOSHA, TÜV, cULus Listed | CCC, CE, EAC (Eurasian), KOSHA, TÜV, cULus Listed |
| Electrical data | 750107 | 751107 | 751187 |
| Supply voltage | | | |
| Voltage | 24 V | 24 V | 24 V |
| Kind | DC | DC | DC |
| Voltage tolerance | -20 %/+20 % | -20 %/+20 % | -20 %/+20 % |
| Output of external power supply (DC) | 2 W | 2 W | 2 W |
| Residual ripple DC | 20 % | 20 % | 20 % |
| Duty cycle | 100 % | 100 % | 100 % |
| Inputs | 750107 | 751107 | 751187 |
| Number | 1 | 1 | 1 |
| Voltage at | | | |
| Input circuit DC | 24 V | 24 V | 24 V |
| Current at | | | |
| Input circuit DC | 70 mA | 70 mA | 70 mA |
| Max. inrush current impulse | | | |
| Current pulse, input circuit | 2,7 A | 2,7 A | 2,7 A |
| Pulse duration, input circuit | 0,1 ms | 0,1 ms | 0,1 ms |
| Max. overall cable resistance R _{lmax} | | | |
| Single-channel at UB DC | 30 Ohm | 30 Ohm | 30 Ohm |
| Relay outputs | 750107 | 751107 | 751187 |
| Number of output contacts | | | |
| Safety contacts (N/O), instantaneous | 4 | 4 | 4 |
| Auxiliary contacts (N/C) | 1 | 1 | 1 |
| Max. short circuit current I _K | 1 kA | 1 kA | 1 kA |
| Utilisation category | | | |
| In accordance with the standard | EN 60947-4-1 | EN 60947-4-1 | EN 60947-4-1 |

Safety relays PNOZsigma PNOZ s7

| Relay outputs | 750107 | 751107 | 751187 |
|--|-------------------------------|-------------------------------|-------------------------------|
| Utilisation category of safety contacts | | | |
| AC1 at | 240 V | 240 V | 240 V |
| Min. current | 0,01 A | 0,01 A | 0,01 A |
| Max. current | 6 A | 6 A | 6 A |
| Max. power | 1500 VA | 1500 VA | 1500 VA |
| DC1 at | 24 V | 24 V | 24 V |
| Min. current | 0,01 A | 0,01 A | 0,01 A |
| Max. current | 6 A | 6 A | 6 A |
| Max. power | 150 W | 150 W | 150 W |
| Utilisation category of auxiliary contacts | | | |
| AC1 at | 240 V | 240 V | 240 V |
| Min. current | 0,01 A | 0,01 A | 0,01 A |
| Max. current | 2 A | 2 A | 2 A |
| Max. power | 500 VA | 500 VA | 500 VA |
| DC1 at | 24 V | 24 V | 24 V |
| Min. current | 0,01 A | 0,01 A | 0,01 A |
| Max. current | 2 A | 2 A | 2 A |
| Max. power | 50 W | 50 W | 50 W |
| Utilisation category | | | |
| In accordance with the standard | EN 60947-5-1 | EN 60947-5-1 | EN 60947-5-1 |
| Utilisation category of safety contacts | | | |
| AC15 at | 230 V | 230 V | 230 V |
| Max. current | 5 A | 5 A | 5 A |
| DC13 (6 cycles/min) at | 24 V | 24 V | 24 V |
| Max. current | 5 A | 5 A | 5 A |
| Utilisation category of auxiliary contacts | | | |
| AC15 at | 230 V | 230 V | 230 V |
| Max. current | 2 A | 2 A | 2 A |
| DC13 (6 cycles/min) at | 24 V | 24 V | 24 V |
| Max. current | 2 A | 2 A | 2 A |
| Utilisation category in accordance with UL | | | |
| Voltage | 240 V AC G.U. (same polarity) | 240 V AC G.U. (same polarity) | 240 V AC G.U. (same polarity) |
| With current | 6 A | 6 A | 6 A |
| Voltage | 24 V DC G. U. | 24 V DC G. U. | 24 V DC G. U. |
| With current | 6 A | 6 A | 6 A |

Safety relays PNOZsigma PNOZ s7

| Relay outputs | 750107 | 751107 | 751187 |
|--|---------------------------|---------------------------|---------------------------|
| External contact fuse protection, safety contacts | | | |
| In accordance with the standard | EN 60947-5-1 | EN 60947-5-1 | EN 60947-5-1 |
| Max. melting integral | 260 A²s | 260 A²s | 260 A²s |
| Blow-out fuse, quick | 10 A | 10 A | 10 A |
| Blow-out fuse, slow | 6 A | 6 A | 6 A |
| Blow-out fuse, gG | 10 A | 10 A | 10 A |
| Circuit breaker 24V AC/DC, characteristic B/C | 6 A | 6 A | 6 A |
| External contact fuse protection, auxiliary contacts | | | |
| Max. melting integral | 160 A²s | 160 A²s | 160 A²s |
| Blow-out fuse, quick | 4 A | 4 A | 4 A |
| Blow-out fuse, slow | 2 A | 2 A | 2 A |
| Blow-out fuse, gG | 4 A | 4 A | 4 A |
| Circuit breaker 24 V AC/DC, characteristic B/C | 2 A | 2 A | 2 A |
| Contact material | AgCuNi + 0,2 µm Au | AgCuNi + 0,2 µm Au | AgCuNi + 0,2 µm Au |
| Conventional thermal current while loading several contacts | 750107 | 751107 | 751187 |
| I _{th} per contact at UB DC; AC1: 240 V, DC1: 24 V | | | |
| Conv. therm. current with 1 contact | 6 A | 6 A | 6 A |
| Conv. therm. current with 2 contacts | 5,5 A | 5,5 A | 5,5 A |
| Conv. therm. current with 3 contacts | 4,5 A | 4,5 A | 4,5 A |
| Conv. therm. current with 4 contacts | 4 A | 4 A | 4 A |
| Times | 750107 | 751107 | 751187 |
| Switch-on delay | | | |
| With automatic start after power on typ. | 30 ms | 30 ms | 30 ms |
| With automatic start after power on max. | 50 ms | 50 ms | 50 ms |

Safety relays PNOZsigma PNOZ s7

| Times | 750107 | 751107 | 751187 |
|--------------------------------------|--|--|--|
| Delay-on de-energisation | | | |
| With E-STOP typ. | 18 ms | 18 ms | 18 ms |
| With E-STOP max. | 30 ms | 30 ms | 30 ms |
| With power failure typ. | 18 ms | 18 ms | 18 ms |
| With power failure max. | 30 ms | 30 ms | 30 ms |
| Environmental data | 750107 | 751107 | 751187 |
| Climatic suitability | EN 60068-2-78 | EN 60068-2-78 | EN 60068-2-78 |
| Ambient temperature | | | |
| Temperature range | -10 - 55 °C | -10 - 55 °C | -10 - 55 °C |
| Storage temperature | | | |
| Temperature range | -40 - 85 °C | -40 - 85 °C | -40 - 85 °C |
| Climatic suitability | | | |
| Humidity | 93 % r. h. at 40 °C | 93 % r. h. at 40 °C | 93 % r. h. at 40 °C |
| Condensation during operation | | | |
| | Not permitted | Not permitted | Not permitted |
| EMC | | | |
| | EN 60947-5-1, EN 61000-6-2, EN 61000-6-4, EN 61326-3-1 | EN 60947-5-1, EN 61000-6-2, EN 61000-6-4, EN 61326-3-1 | EN 60947-5-1, EN 61000-6-2, EN 61000-6-4, EN 61326-3-1 |
| Vibration | | | |
| In accordance with the standard | EN 60068-2-6 | EN 60068-2-6 | EN 60068-2-6 |
| Frequency | 10 - 55 Hz | 10 - 55 Hz | 10 - 55 Hz |
| Amplitude | 0,35 mm | 0,35 mm | 0,35 mm |
| Airgap creepage | | | |
| In accordance with the standard | EN 60947-1 | EN 60947-1 | EN 60947-1 |
| Overvoltage category | III | III | III |
| Pollution degree | 2 | 2 | 2 |
| Rated insulation voltage | 250 V | 250 V | 250 V |
| Rated impulse withstand voltage | 6 kV | 6 kV | 6 kV |
| Protection type | | | |
| Mounting area (e.g. control cabinet) | IP54 | IP54 | IP54 |
| Housing | IP40 | IP40 | IP40 |
| Terminals | IP20 | IP20 | IP20 |
| Mechanical data | 750107 | 751107 | 751187 |
| Mounting position | Any | Any | Any |
| Mechanical life | 10,000,000 cycles | 10,000,000 cycles | 10,000,000 cycles |

Safety relays PNOZsigma PNOZ s7

| Mechanical data | 750107 | 751107 | 751187 |
|---|--|---|---|
| Material | | | |
| Bottom | PC | PC | PC |
| Front | PC | PC | PC |
| Top | PC | PC | PC |
| Connection type | Screw terminal | Cage clamp terminal | Cage clamp terminal |
| Mounting type | plug-in | plug-in | plug-in |
| Conductor cross section with screw terminals | | | |
| 1 core flexible | 0,25 - 2,5 mm ² , 24 - 12 AWG | – | – |
| 2 core with the same cross section, flexible with crimp connectors, no plastic sleeve | 0,25 - 1 mm ² , 24 - 16 AWG | – | – |
| 2 core with the same cross section, flexible without crimp connectors or with TWIN crimp connectors | 0,2 - 1,5 mm ² , 24 - 16 AWG | – | – |
| Torque setting with screw terminals | 0,5 Nm | – | – |
| Conductor cross section with spring-loaded terminals: Flexible with/without crimp connector | – | 0,2 - 2,5 mm ² , 24 - 12 AWG | 0,2 - 2,5 mm ² , 24 - 12 AWG |
| Spring-loaded terminals: Terminal points per connection | – | 2 | 2 |
| Stripping length with spring-loaded terminals | – | 9 mm | 9 mm |
| Dimensions | | | |
| Height | 98 mm | 100 mm | 100 mm |
| Width | 17,5 mm | 17,5 mm | 17,5 mm |
| Depth | 120 mm | 120 mm | 120 mm |
| Weight | 170 g | 170 g | 170 g |

Where standards are undated, the 2014-07 latest editions shall apply.

Safety relays PNOZsigma PNOZ s7

Safety characteristic data

| Operating Mode | EN ISO 13849-1: 2015 PL | EN ISO 13849-1: 2015 Category | EN 62061 SIL CL | EN 62061 PFH _D [1/h] | IEC 61511 SIL | IEC 61511 PFD | EN ISO 13849-1: 2015 T _M [year] |
|--------------------------------|----------------------------|----------------------------------|--------------------|------------------------------------|------------------|------------------|---|
| Safety contacts, instantaneous | PL e | Cat. 4 | SIL CL 3 | 2,31E-09 | SIL 3 | 2,03E-06 | 20 |

All the units used within a safety function must be considered when calculating the safety characteristic data.

Supplementary data

The PFH value depends on the switching frequency and the load on the relay output. If the service life graphs are not accessible, the stated PFH value can be used irrespective of the switching frequency and the load, as the PFH value already considers the relay's B10d value as well as the failure rates of the other components.

Safety relays PNOZsigma PNOZ s7

Service life graph

The service life graphs indicate the number of cycles from which failures due to wear must be expected. The wear is mainly caused by the electrical load; the mechanical load is negligible.

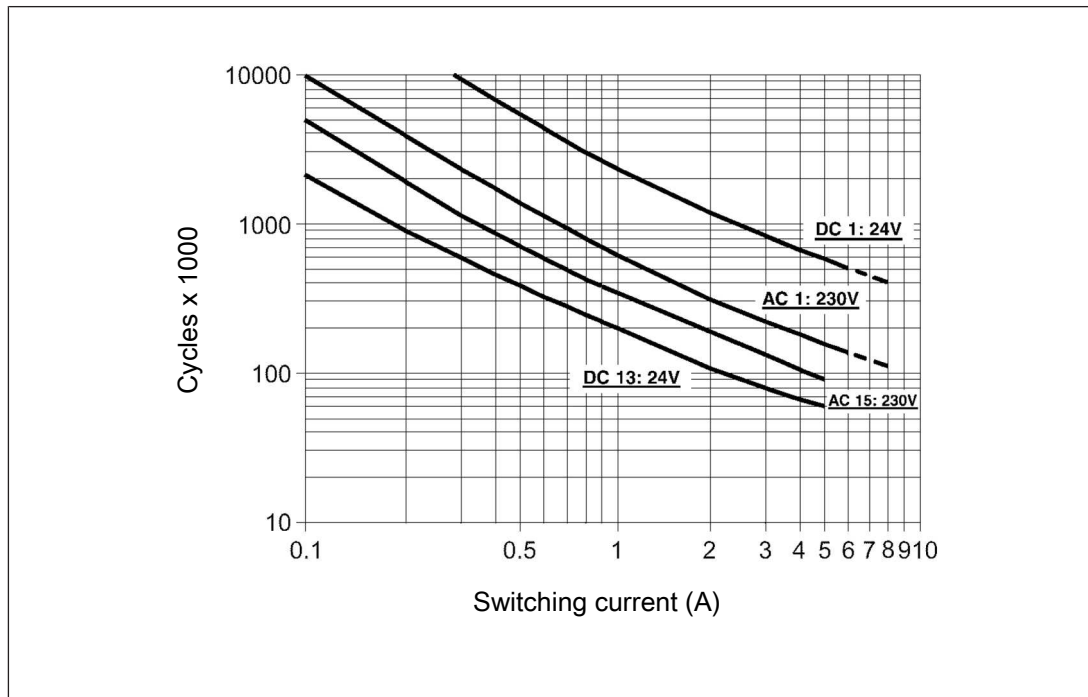

Fig.: Service life graphs at 24 V DC and 230 V AC

Safety relays PNOZsigma PNOZ s7

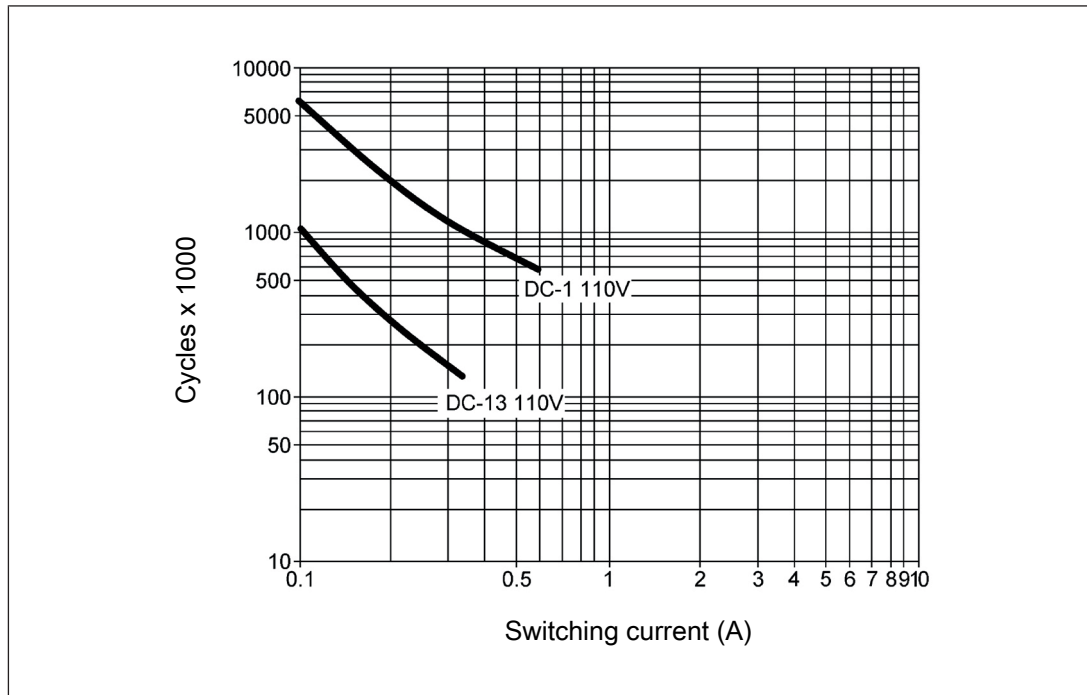

Fig.: Service life graphs at 110 V DC

Example

- ▶ Inductive load: 0.2 A
- ▶ Utilisation category: AC15
- ▶ Contact service life: 2 000 000 cycles

Provided the application to be implemented requires fewer than 2 000 000 cycles, the PFH value (see [Technical details \[708\]](#)) can be used in the calculation.

To increase the service life, sufficient spark suppression must be provided on all output contacts. With capacitive loads, any power surges that occur must be noted. With DC contactors, use flywheel diodes for spark suppression.

Order reference

| Product type | Features | Terminals | Order No. |
|-------------------------------|----------|-------------------------|-----------|
| PNOZ s7 | 24 VDC | Screw terminals | 750 107 |
| PNOZ s7 C | 24 VDC | Spring-loaded terminals | 751 107 |
| PNOZ s7 C (coated version) | 24 VDC | Spring-loaded terminals | 751 187 |

Safety relays PNOZsigma PNOZ s7.1

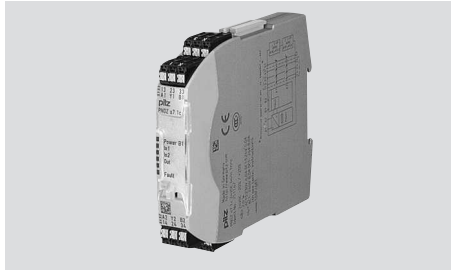

Unit features

- ▶ Relay outputs:
 - 3 safety contacts (N/O), instantaneous
- ▶ Supply voltage for expansion modules
- ▶ LED for:
 - Supply voltage at B1 and B2
 - Input status, channel 1
 - Input status, channel 2
 - Switch status of the safety contacts
 - Fault
- ▶ Plug-in connection terminals (either spring-loaded terminal or screw terminal)
- ▶ See order reference for unit types

Safety relays PNOZsigma PNOZ s7.1

Block diagram/terminal configuration

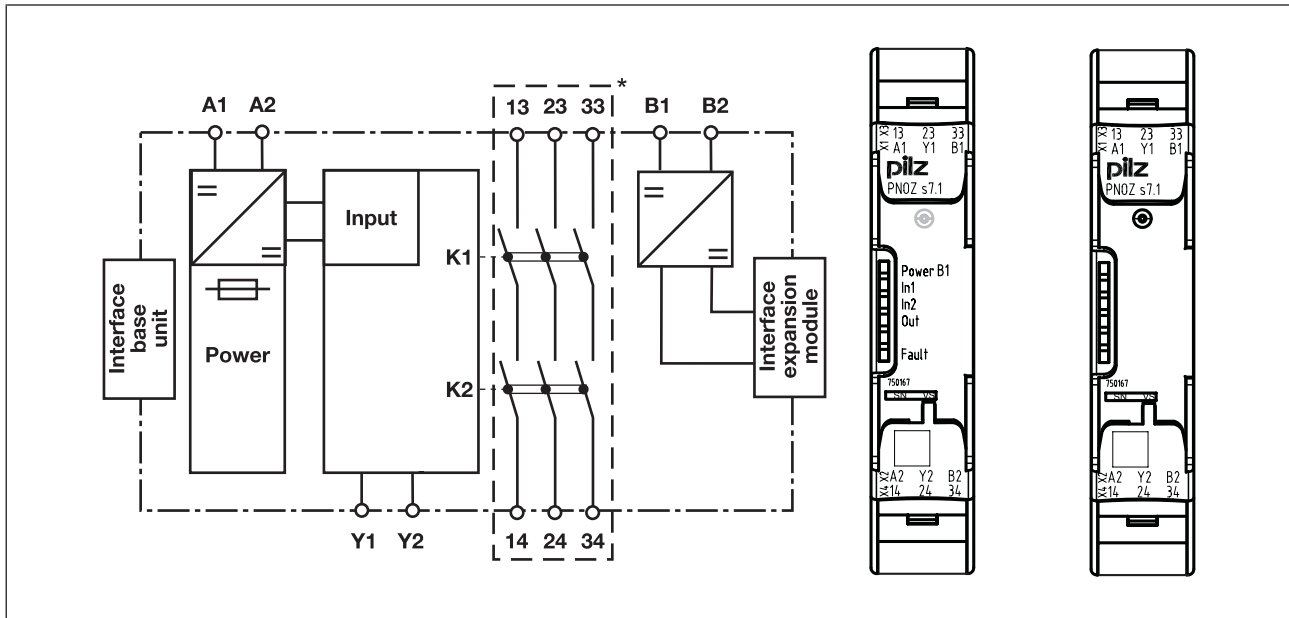

Fig.: Centre: Front view with cover, right: Front view without cover

*Safe separation from non-marked area in accordance with EN 60947-1, 6 kV, basic insulation between all safety contacts.

Function description

with PNOZsigma base unit:

- ▶ Dual-channel operation via PNOZsigma connector

without PNOZsigma base unit:

- ▶ Single-channel operation: one input circuit affects the output relays
- ▶ Connection for base unit

with PNOZsigma s7.2 expansion modules:

- ▶ Dual-channel operation and supply voltage via PNOZsigma connector

Safety relays PNOZsigma PNOZ s7.1

Timing diagram

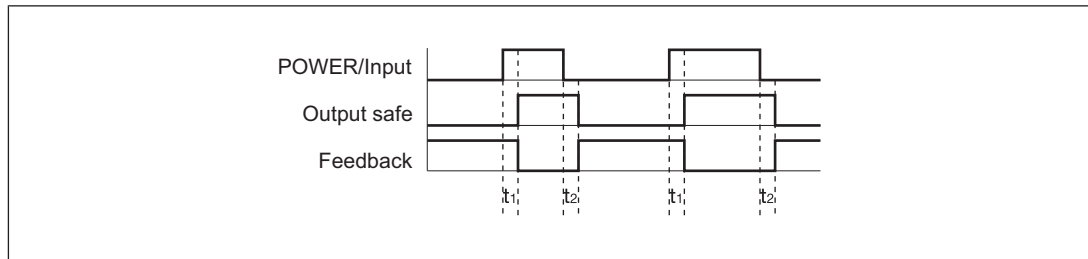

Legend

- ▶ POWER/Input: Supply voltage/Input
- ▶ Output safe: Safety contacts
- ▶ Feedback: Feedback loop
- ▶ t_1 : Switch-on delay
- ▶ t_2 : Delay-on de-energisation

Installation

Install contact expansion module without base unit:

- ▶ Ensure that the plug terminator is inserted at the side of the unit.

Connect base unit and contact expansion module PNOZ s7.1:

- ▶ Remove the plug terminator at the side of the base unit and at the left of the contact expansion module
- ▶ Connect the base unit and the contact expansion module using the connector supplied, before mounting the units to the DIN rail.

Connect contact expansion module PNOZ s7.1 to PNOZsigma contact expansion modules

- ▶ Connect the contact expansion modules using the connector supplied.

Control cabinet installation

- ▶ The safety relay should be installed in a control cabinet with a protection type of at least IP54.
- ▶ Use the notch on the rear of the unit to attach it to a DIN rail (35 mm).
- ▶ When installed vertically: Secure the unit by using a fixing element (e.g. retaining bracket or end angle).

Push the unit upwards or downwards before lifting it from the DIN rail.

Safety relays PNOZsigma PNOZ s7.1

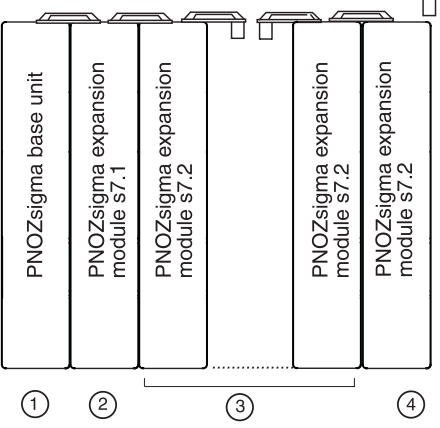
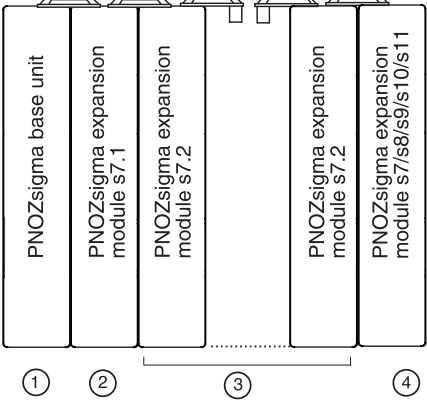
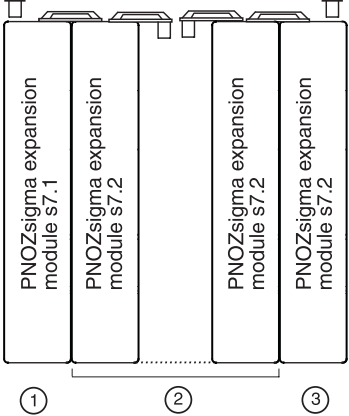
| Expansion options | Please note the max. power consumption of the contact expansion modules (see technical data PNOZ s7.1). |
|--|---|
| <p>①: Base unit ②: Contact expansion module PNOZ s7.1 ③: Contact expansion module PNOZ s7.2 ④: Contact expansion module PNOZ s7.2 with terminator</p> |  |
| <p>①: Base unit ②: Contact expansion module PNOZ s7.1 ③: Contact expansion module PNOZ s7.2 ④: Expansion module PNOZ s7, s8, s9, s10, s11 as a terminator</p> |  |
| <p>①: Contact expansion module PNOZ s7.1 with terminator ②: Contact expansion module PNOZ s7.2 ③: Contact expansion module PNOZ s7.2 with terminator</p> |  |

Safety relays PNOZsigma PNOZ s7.1

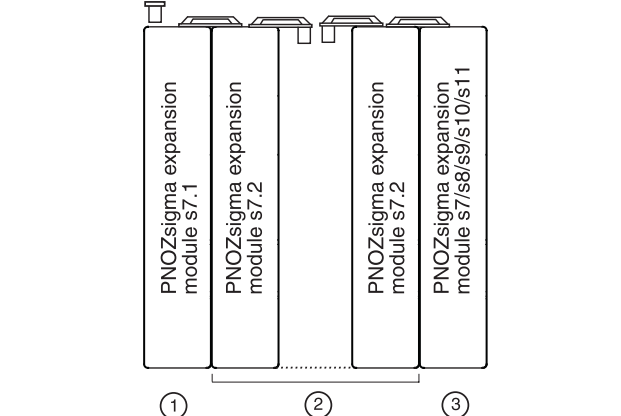
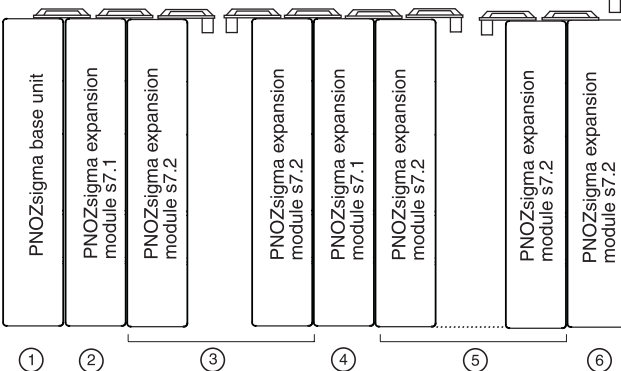
| Expansion options | Please note the max. power consumption of the contact expansion modules (see technical data PNOZ s7.1). |
|--|---|
| <p>①: Contact expansion module PNOZ s7.1 with terminator</p> <p>②: Contact expansion module PNOZ s7.2</p> <p>③: Expansion module PNOZ s7, s8, s9, s10, s11 as a terminator</p> |  |
| <p>①: Base unit</p> <p>②: Contact expansion module PNOZ s7.1</p> <p>③: Contact expansion module PNOZ s7.2</p> <p>④: Contact expansion module PNOZ s7.1</p> <p>⑤: Contact expansion module PNOZ s7.2</p> <p>⑥: Contact expansion module PNOZ s7.2 with terminator</p> |  |

Wiring

Please note:

- ▶ Information given in the "[Technical details \[723\]](#)" must be followed.
- ▶ The output contacts 13-14, 23-24, 33-34 are safety contacts.
- ▶ To prevent contact welding, a fuse should be connected before the output contacts (see [Technical details \[723\]](#)).
- ▶ Calculation of the max. cable length I_{max} in the input circuit:

$$I_{max} = \frac{R_{I_{max}}}{R_l / km}$$

$R_{I_{max}}$ = max. overall cable resistance (see [Technical details \[723\]](#))

R_l / km = cable resistance/km

- ▶ Use copper wire that can withstand 60/75 °C.
- ▶ Sufficient fuse protection must be provided on all output contacts with capacitive and inductive loads.

Safety relays PNOZsigma PNOZ s7.1

- ▶ Ensure the wiring and EMC requirements of IEC 60204-1 are met.
- ▶ The power supply must comply with the regulations for extra low voltages with protective electrical separation (SELV, PELV) in accordance with VDE 0100, Part 410.

Preparing for operation

| Supply voltage | AC | DC |
|---|----------------|--------------|
| Base unit: Safety relay PNOZsigma | | |
| Base unit: Safety relay PNOZ X | | |
| Supply voltage for expansion modules PNOZsigma | | |
| Input circuit | Single-channel | Dual-channel |
| Base unit: Safety relay PNOZsigma | | |
| Base unit: Safety relay PNOZ X | | |
| Base unit: Safety relay PNOZelog driven via semiconductor outputs (24 VDC) | | |

Safety relays PNOZsigma PNOZ s7.1

| Start circuit/feedback loop | Base unit: Safety relay PNOZ X | Base unit: Safety relay PNOZelog |
|---|-----------------------------------|--|
| The inputs that evaluate the feedback loop will depend on the base unit and application | | |
| Connection to PNOZsigma base unit/PNOZmulti Mini base unit | Base unit: Safety relay PNOZsigma | Base unit: Small control system PNOZmulti Mini |
| The feedback loop is connected and evaluated via the connector | | |

Dimensions in mm

*with spring-loaded terminals

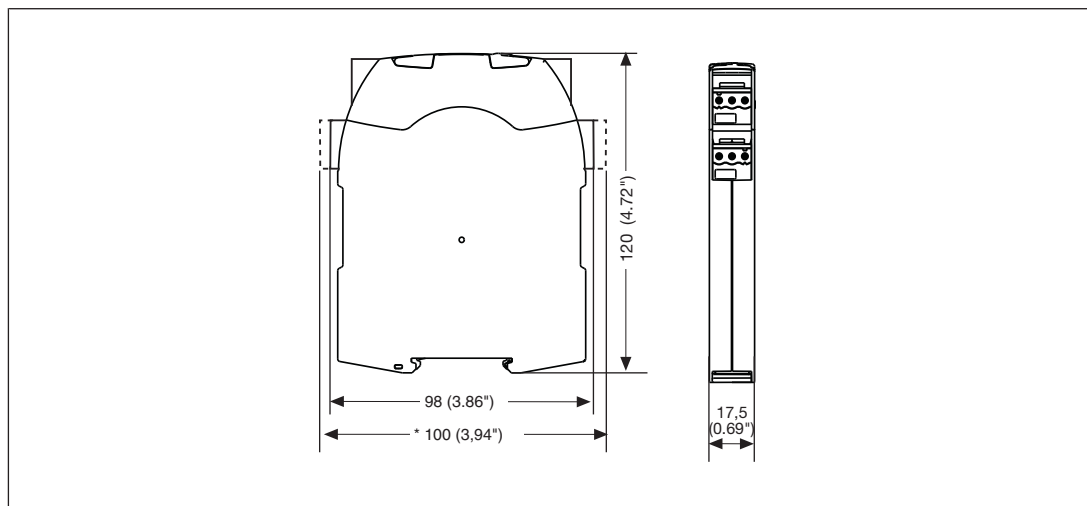

Safety relays PNOZsigma PNOZ s7.1

Technical details

| General | 750167 | 751167 |
|---|--|--|
| Approvals | CCC, CE, EAC (Eurasian), TÜV, cULus Listed | CCC, CE, EAC (Eurasian), TÜV, cULus Listed |
| Electrical data | 750167 | 751167 |
| Supply voltage | | |
| Voltage | 24 V | 24 V |
| Kind | DC | DC |
| Voltage tolerance | -20 %/+20 % | -20 %/+20 % |
| Output of external power supply (DC) | 2 W | 2 W |
| Residual ripple DC | 20 % | 20 % |
| Duty cycle | 100 % | 100 % |
| Max. power of all expansion modules | 20 W | 20 W |
| Inputs | 750167 | 751167 |
| Number | 1 | 1 |
| Voltage at | | |
| Input circuit DC | 24 V | 24 V |
| Current at | | |
| Input circuit DC | 70 mA | 70 mA |
| Max. inrush current impulse | | |
| Current pulse, input circuit | 2 A | 2 A |
| Pulse duration, input circuit | 0,1 ms | 0,1 ms |
| Max. overall cable resistance RI-max | | |
| Single-channel at UB DC | 30 Ohm | 30 Ohm |
| Relay outputs | 750167 | 751167 |
| Number of output contacts | | |
| Safety contacts (N/O), instantaneous | 3 | 3 |
| Max. short circuit current I _K | 1 kA | 1 kA |
| Utilisation category | | |
| In accordance with the standard | EN 60947-4-1 | EN 60947-4-1 |

Safety relays PNOZsigma PNOZ s7.1

| Relay outputs | 750167 | 751167 |
|---|-------------------------------|-------------------------------|
| Utilisation category of safety contacts | | |
| AC1 at | 240 V | 240 V |
| Min. current | 0,01 A | 0,01 A |
| Max. current | 6 A | 6 A |
| Max. power | 1500 VA | 1500 VA |
| DC1 at | 24 V | 24 V |
| Min. current | 0,01 A | 0,01 A |
| Max. current | 6 A | 6 A |
| Max. power | 150 W | 150 W |
| Utilisation category | | |
| In accordance with the standard | EN 60947-5-1 | EN 60947-5-1 |
| Utilisation category of safety contacts | | |
| AC15 at | 230 V | 230 V |
| Max. current | 5 A | 5 A |
| DC13 (6 cycles/min) at | 24 V | 24 V |
| Max. current | 5 A | 5 A |
| Utilisation category in accordance with UL | | |
| Voltage | 240 V AC G.U. (same polarity) | 240 V AC G.U. (same polarity) |
| With current | 6 A | 6 A |
| Voltage | 24 V DC G. U. | 24 V DC G. U. |
| With current | 6 A | 6 A |
| External contact fuse protection, safety contacts | | |
| In accordance with the standard | EN 60947-5-1 | EN 60947-5-1 |
| Max. melting integral | 260 A ² s | 260 A ² s |
| Blow-out fuse, quick | 10 A | 10 A |
| Blow-out fuse, slow | 6 A | 6 A |
| Blow-out fuse, gG | 10 A | 10 A |
| Circuit breaker 24V AC/DC, characteristic B/C | 6 A | 6 A |
| Contact material | AgCuNi + 0,2 µm Au | AgCuNi + 0,2 µm Au |

Safety relays PNOZsigma PNOZ s7.1

| Conventional thermal current while loading several contacts | 750167 | 751167 |
|--|---|---|
| Ith per contact at UB DC; AC1: 240 V, DC1: 24 V | | |
| Conv. therm. current with 1 contact | 6 A | 6 A |
| Conv. therm. current with 2 contacts | 5,5 A | 5,5 A |
| Conv. therm. current with 3 contacts | 4,5 A | 4,5 A |
| Times | 750167 | 751167 |
| Switch-on delay | | |
| With automatic start after power on typ. | 30 ms | 30 ms |
| With automatic start after power on max. | 50 ms | 50 ms |
| Delay-on de-energisation | | |
| With E-STOP typ. | 18 ms | 18 ms |
| With E-STOP max. | 30 ms | 30 ms |
| With power failure typ. | 18 ms | 18 ms |
| With power failure max. | 30 ms | 30 ms |
| Supply interruption before de-energisation | 5 ms | 5 ms |
| Environmental data | 750167 | 751167 |
| Climatic suitability | EN 60068-2-78 | EN 60068-2-78 |
| Ambient temperature | | |
| Temperature range | -10 - 55 °C | -10 - 55 °C |
| Storage temperature | | |
| Temperature range | -40 - 85 °C | -40 - 85 °C |
| Climatic suitability | | |
| Humidity | 93 % r. h. at 40 °C | 93 % r. h. at 40 °C |
| Condensation during operation | Not permitted | Not permitted |
| EMC | EN 60947-5-1, EN 61000-6-2, EN 61000-6-4, EN 61326-3-1 | EN 60947-5-1, EN 61000-6-2, EN 61000-6-4, EN 61326-3-1 |
| Vibration | | |
| In accordance with the standard | EN 60068-2-6 | EN 60068-2-6 |
| Frequency | 10 - 55 Hz | 10 - 55 Hz |
| Amplitude | 0,35 mm | 0,35 mm |
| Airgap creepage | | |
| In accordance with the standard | EN 60947-1 | EN 60947-1 |
| Overvoltage category | III | III |
| Pollution degree | 2 | 2 |
| Rated insulation voltage | 250 V | 250 V |

Safety relays PNOZsigma PNOZ s7.1

| Environmental data | 750167 | 751167 |
|---|---|--|
| Rated impulse withstand voltage | 6 kV | 6 kV |
| Protection type | | |
| Mounting area (e.g. control cabinet) | IP54 | IP54 |
| Housing | IP40 | IP40 |
| Terminals | IP20 | IP20 |
| Mechanical data | 750167 | 751167 |
| Mounting position | Any | Any |
| Mechanical life | 10,000,000 cycles | 10,000,000 cycles |
| Material | | |
| Bottom | PC | PC |
| Front | PC | PC |
| Top | PC | PC |
| Connection type | Screw terminal | Cage clamp terminal |
| Mounting type | plug-in | plug-in |
| Conductor cross section with screw terminals | | |
| 1 core flexible | 0,25 - 2,5 mm², 24 - 12 AWG | – |
| 2 core with the same cross section, flexible with crimp connectors, no plastic sleeve | 0,25 - 1 mm², 24 - 16 AWG | – |
| 2 core with the same cross section, flexible without crimp connectors or with TWIN crimp connectors | 0,2 - 1,5 mm², 24 - 16 AWG | – |
| Torque setting with screw terminals | 0,5 Nm | – |
| Conductor cross section with spring-loaded terminals: Flexible with/without crimp connector | | |
| | – | 0,2 - 2,5 mm², 24 - 12 AWG |
| Spring-loaded terminals: Terminal points per connection | | |
| | – | 2 |
| Stripping length with spring-loaded terminals | | |
| | – | 9 mm |
| Dimensions | | |
| Height | 98 mm | 100 mm |
| Width | 17,5 mm | 17,5 mm |
| Depth | 120 mm | 120 mm |
| Weight | 170 g | 170 g |

Where standards are undated, the 2014-07 latest editions shall apply.

Safety relays PNOZsigma PNOZ s7.1

Safety characteristic data

| Operating Mode | EN ISO 13849-1: 2015 PL | EN ISO 13849-1: 2015 Category | EN 62061 SIL CL | EN 62061 PFH _D [1/h] | IEC 61511 SIL | IEC 61511 PFD | EN ISO 13849-1: 2015 T _M [year] |
|--------------------------------|----------------------------|----------------------------------|--------------------|------------------------------------|------------------|------------------|---|
| Safety contacts, instantaneous | PL e | Cat. 4 | SIL CL 3 | 2,31E-09 | SIL 3 | 2,03E-06 | 20 |

All the units used within a safety function must be considered when calculating the safety characteristic data.

Supplementary data

The PFH value depends on the switching frequency and the load on the relay output. If the service life graphs are not accessible, the stated PFH value can be used irrespective of the switching frequency and the load, as the PFH value already considers the relay's B10d value as well as the failure rates of the other components.

Safety relays PNOZsigma PNOZ s7.1

Service life graph

The service life graphs indicate the number of cycles from which failures due to wear must be expected. The wear is mainly caused by the electrical load; the mechanical load is negligible.

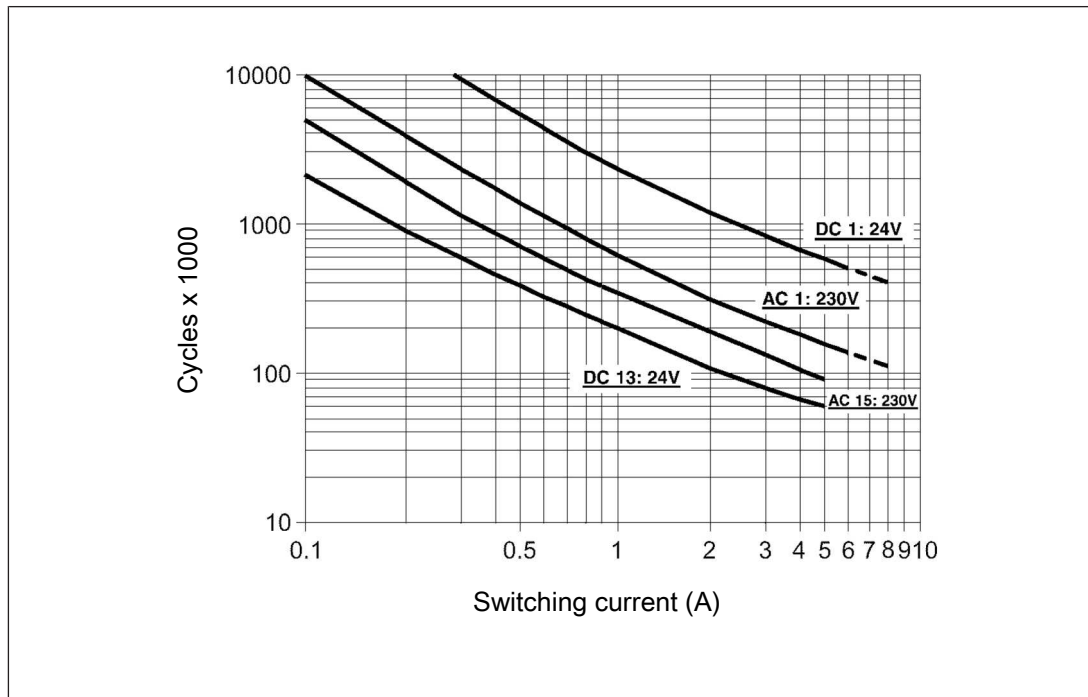

Fig.: Service life graphs at 24 V DC and 230 V AC

Safety relays PNOZsigma PNOZ s7.1

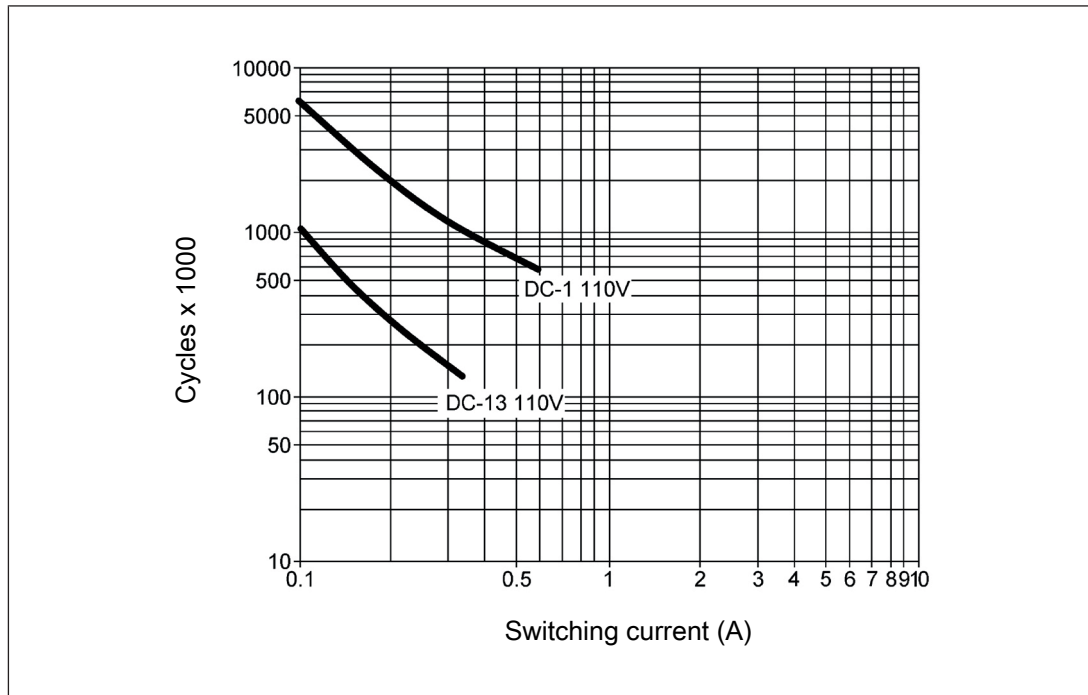

Fig.: Service life graphs at 110 V DC

Example

- ▶ Inductive load: 0.2 A
- ▶ Utilisation category: AC15
- ▶ Contact service life: 2 000 000 cycles

Provided the application to be implemented requires fewer than 2 000 000 cycles, the PFH value (see [Technical details \[723\]](#)) can be used in the calculation.

To increase the service life, sufficient spark suppression must be provided on all output contacts. With capacitive loads, any power surges that occur must be noted. With DC contactors, use flywheel diodes for spark suppression.

Order reference

| Product type | Features | Connection type | Order No. |
|--------------|----------|-------------------------|-----------|
| PNOZ s7.1 | 24 VDC | Screw terminals | 750 167 |
| PNOZ s7.1 C | 24 VDC | Spring-loaded terminals | 751 167 |

Safety relays PNOZsigma PNOZ s7.2

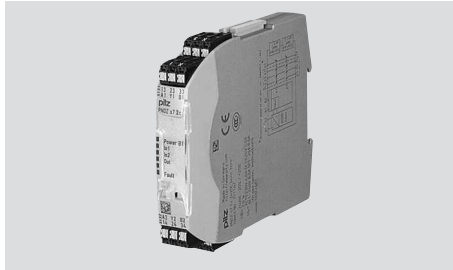

Unit features

- ▶ Positive-guided relay outputs:
 - 4 safety contacts (N/O), instantaneous
 - 1 auxiliary contact (N/C), instantaneous
- ▶ Connection option for expansion modules
- ▶ LED for:
 - Input status, channel 1
 - Input status, channel 2
 - Switch status of the safety contacts
- ▶ Plug-in connection terminals (either spring-loaded terminal or screw terminal)
- ▶ See order reference for unit types

Safety relays PNOZsigma PNOZ s7.2

Block diagram/terminal configuration

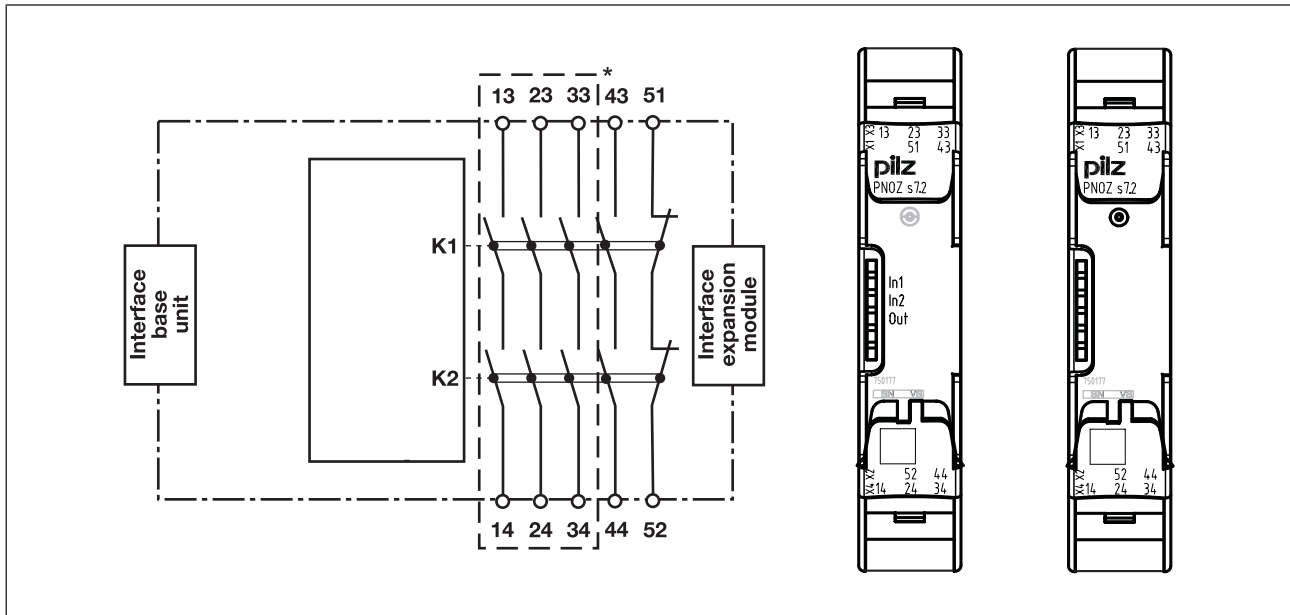

Fig.: Centre: Front view with cover, right: Front view without cover

*Safe separation from non-marked area in accordance with EN 60947-1, 6 kV, basic insulation between all safety contacts.

Function description

with PNOZsigma s7.1:

- ▶ Dual-channel operation and supply voltage via PNOZsigma connector

with PNOZsigma expander modules:

- ▶ Dual-channel operation and supply voltage via PNOZsigma connector

Installation

Connect contact expansion module PNOZ s7.2 to PNOZsigma contact expansion modules

- ▶ Connect the contact expansion modules using the connector supplied.

Control cabinet installation

- ▶ The safety relay should be installed in a control cabinet with a protection type of at least IP54.
- ▶ Use the notch on the rear of the unit to attach it to a DIN rail.
- ▶ Ensure the unit is mounted securely on a vertical DIN rail (35 mm) by using a fixing element (e.g. retaining bracket or an end angle).

Push the unit upwards or downwards before lifting it from the DIN rail.

Safety relays PNOZsigma PNOZ s7.2

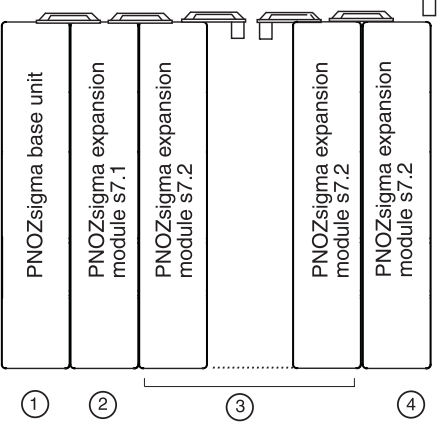
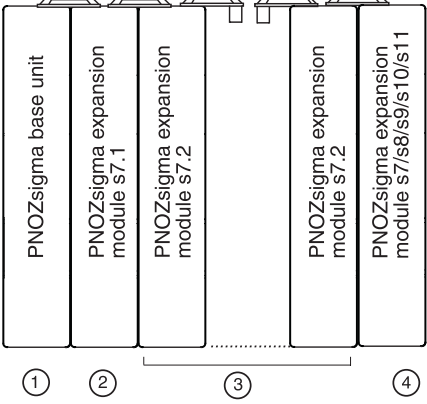
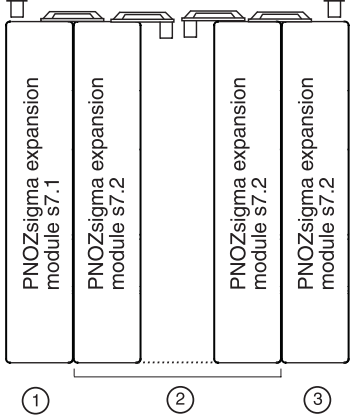
| Expansion options | Please note the max. power consumption of the contact expansion modules (see technical data PNOZ s7.1). |
|--|---|
| <p>①: Base unit ②: Contact expansion module PNOZ s7.1 ③: Contact expansion module PNOZ s7.2 ④: Contact expansion module PNOZ s7.2 with terminator</p> |  |
| <p>①: Base unit ②: Contact expansion module PNOZ s7.1 ③: Contact expansion module PNOZ s7.2 ④: Expansion module PNOZ s7, s8, s9, s10, s11 as a terminator</p> |  |
| <p>①: Contact expansion module PNOZ s7.1 with terminator ②: Contact expansion module PNOZ s7.2 ③: Contact expansion module PNOZ s7.2 with terminator</p> |  |

Safety relays PNOZsigma PNOZ s7.2

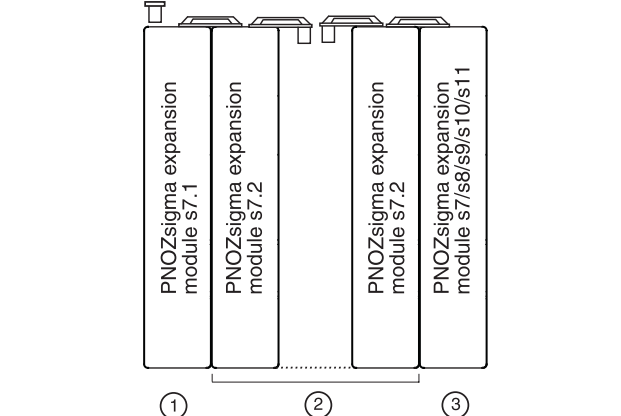
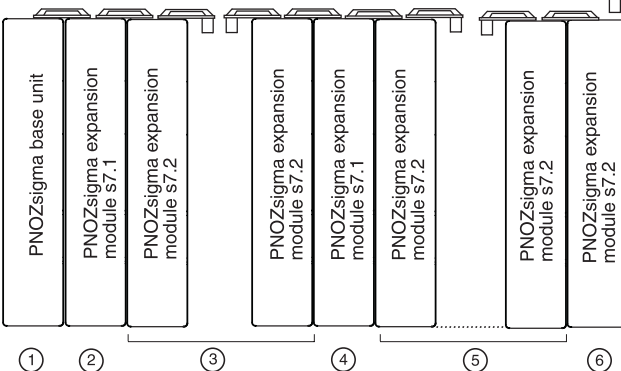
| Expansion options | Please note the max. power consumption of the contact expansion modules (see technical data PNOZ s7.1). |
|--|---|
| <p>①: Contact expansion module PNOZ s7.1 with terminator</p> <p>②: Contact expansion module PNOZ s7.2</p> <p>③: Expansion module PNOZ s7, s8, s9, s10, s11 as a terminator</p> |  |
| <p>①: Base unit</p> <p>②: Contact expansion module PNOZ s7.1</p> <p>③: Contact expansion module PNOZ s7.2</p> <p>④: Contact expansion module PNOZ s7.1</p> <p>⑤: Contact expansion module PNOZ s7.2</p> <p>⑥: Contact expansion module PNOZ s7.2 with terminator</p> |  |

Wiring

Please note:

- ▶ Information given in the "[Technical details \[735\]](#)" must be followed.
- ▶ Outputs 13-14, 23-24, 33-34, 43-44 are safety contacts; outputs 51 -52 are auxiliary contacts (e.g. for display).
- ▶ Auxiliary contact 51-52 should **not** be used for safety circuits!
- ▶ To prevent contact welding, a fuse should be connected before the output contacts (see [Technical details \[735\]](#)).
- ▶ Use copper wire that can withstand 60/75 °C.
- ▶ Sufficient fuse protection must be provided on all output contacts with capacitive and inductive loads.

Safety relays PNOZsigma PNOZ s7.2

Preparing for operation

| Supply voltage/input circuit/ feedback loop | AC | DC |
|---|--|---|
| Contact expansion module PNOZ s7.2 | | |
| Connection to PNOZsigma base unit/PNOZmulti Mini base unit | Base unit: Safety relay PNOZ- sigma | Base unit: Small control system PNOZmulti Mini |
| The feedback loop is connected and evaluated via the connector | | |

Dimensions in mm

*with spring-loaded terminals

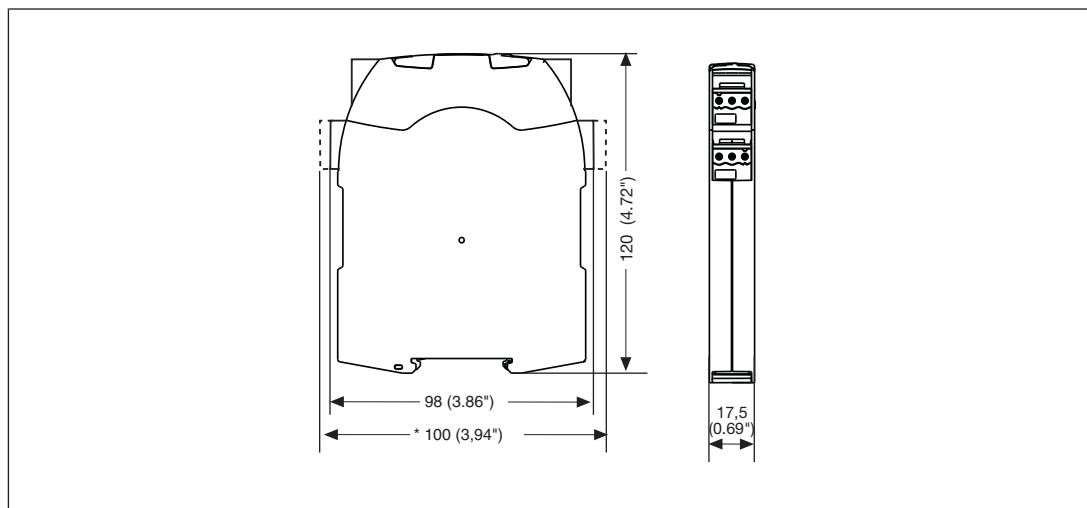

Safety relays PNOZsigma PNOZ s7.2

Technical details

| General | 750177 | 751177 |
|---|--|--|
| Approvals | CCC, CE, EAC (Eurasian), TÜV, cULus Listed | CCC, CE, EAC (Eurasian), TÜV, cULus Listed |
| Electrical data | 750177 | 751177 |
| Supply voltage | | |
| Voltage | 24 V | 24 V |
| Kind | DC | DC |
| Power consumption | 2 W | 2 W |
| Duty cycle | 100 % | 100 % |
| Inputs | 750177 | 751177 |
| Max. overall cable resistance RI-max | | |
| Single-channel at UB DC | 30 Ohm | 30 Ohm |
| Relay outputs | 750177 | 751177 |
| Number of output contacts | | |
| Safety contacts (N/O), instantaneous | 4 | 4 |
| Auxiliary contacts (N/C) | 1 | 1 |
| Max. short circuit current IK | 1 kA | 1 kA |
| Utilisation category | | |
| In accordance with the standard | EN 60947-4-1 | EN 60947-4-1 |
| Utilisation category of safety contacts | | |
| AC1 at | 240 V | 240 V |
| Min. current | 0,01 A | 0,01 A |
| Max. current | 6 A | 6 A |
| Max. power | 1500 VA | 1500 VA |
| DC1 at | 24 V | 24 V |
| Min. current | 0,01 A | 0,01 A |
| Max. current | 6 A | 6 A |
| Max. power | 150 W | 150 W |

Safety relays PNOZsigma PNOZ s7.2

| Relay outputs | 750177 | 751177 |
|---|-------------------------------|-------------------------------|
| Utilisation category of auxiliary contacts | | |
| AC1 at | 240 V | 240 V |
| Min. current | 0,01 A | 0,01 A |
| Max. current | 2 A | 2 A |
| Max. power | 500 VA | 500 VA |
| DC1 at | 24 V | 24 V |
| Min. current | 0,01 A | 0,01 A |
| Max. current | 2 A | 2 A |
| Max. power | 50 W | 50 W |
| Utilisation category | | |
| In accordance with the standard | EN 60947-5-1 | EN 60947-5-1 |
| Utilisation category of safety contacts | | |
| AC15 at | 230 V | 230 V |
| Max. current | 5 A | 5 A |
| DC13 (6 cycles/min) at | 24 V | 24 V |
| Max. current | 5 A | 5 A |
| Utilisation category of auxiliary contacts | | |
| AC15 at | 230 V | 230 V |
| Max. current | 2 A | 2 A |
| DC13 (6 cycles/min) at | 24 V | 24 V |
| Max. current | 2 A | 2 A |
| Utilisation category in accordance with UL | | |
| Voltage | 240 V AC G.U. (same polarity) | 240 V AC G.U. (same polarity) |
| With current | 6 A | 6 A |
| Voltage | 24 V DC G. U. | 24 V DC G. U. |
| With current | 6 A | 6 A |
| External contact fuse protection, safety contacts | | |
| In accordance with the standard | EN 60947-5-1 | EN 60947-5-1 |
| Max. melting integral | 260 A ² s | 260 A ² s |
| Blow-out fuse, quick | 10 A | 10 A |
| Blow-out fuse, slow | 6 A | 6 A |
| Blow-out fuse, gG | 10 A | 10 A |
| Circuit breaker 24V AC/DC, characteristic B/C | 6 A | 6 A |

Safety relays PNOZsigma PNOZ s7.2

| Relay outputs | 750177 | 751177 |
|--|--|--|
| External contact fuse protection, auxiliary contacts | | |
| Max. melting integral | 160 A ² s | 160 A ² s |
| Blow-out fuse, quick | 4 A | 4 A |
| Blow-out fuse, slow | 2 A | 2 A |
| Blow-out fuse, gG | 4 A | 4 A |
| Circuit breaker 24 V AC/DC, characteristic B/C | 2 A | 2 A |
| Contact material | AgCuNi + 0,2 µm Au | AgCuNi + 0,2 µm Au |
| Conventional thermal current while loading several contacts | 750177 | 751177 |
| I _{th} per contact at UB DC; AC1: 240 V, DC1: 24 V | | |
| Conv. therm. current with 1 contact | 6 A | 6 A |
| Conv. therm. current with 2 contacts | 5,5 A | 5,5 A |
| Conv. therm. current with 3 contacts | 4,5 A | 4,5 A |
| Conv. therm. current with 4 contacts | 4 A | 4 A |
| Times | 750177 | 751177 |
| Switch-on delay | | |
| With automatic start after power on typ. | 30 ms | 30 ms |
| With automatic start after power on max. | 50 ms | 50 ms |
| Delay-on de-energisation | | |
| With E-STOP typ. | 18 ms | 18 ms |
| With E-STOP max. | 30 ms | 30 ms |
| With power failure typ. | 18 ms | 18 ms |
| With power failure max. | 30 ms | 30 ms |
| Environmental data | 750177 | 751177 |
| Climatic suitability | EN 60068-2-78 | EN 60068-2-78 |
| Ambient temperature | | |
| Temperature range | -10 - 55 °C | -10 - 55 °C |
| Storage temperature | | |
| Temperature range | -40 - 85 °C | -40 - 85 °C |
| Climatic suitability | | |
| Humidity | 93 % r. h. at 40 °C | 93 % r. h. at 40 °C |
| Condensation during operation | Not permitted | Not permitted |
| EMC | EN 60947-5-1, EN 61000-6-2, EN 61000-6-4, EN 61326-3-1 | EN 60947-5-1, EN 61000-6-2, EN 61000-6-4, EN 61326-3-1 |

Safety relays PNOZsigma PNOZ s7.2

| Environmental data | 750177 | 751177 |
|---|---|--|
| Vibration | | |
| In accordance with the standard | EN 60068-2-6 | EN 60068-2-6 |
| Frequency | 10 - 55 Hz | 10 - 55 Hz |
| Amplitude | 0,35 mm | 0,35 mm |
| Airgap creepage | | |
| In accordance with the standard | EN 60947-1 | EN 60947-1 |
| Overvoltage category | III | III |
| Pollution degree | 2 | 2 |
| Rated insulation voltage | 250 V | 250 V |
| Rated impulse withstand voltage | 6 kV | 6 kV |
| Protection type | | |
| Mounting area (e.g. control cabinet) | IP54 | IP54 |
| Housing | IP40 | IP40 |
| Terminals | IP20 | IP20 |
| Mechanical data | 750177 | 751177 |
| Mounting position | Any | Any |
| Mechanical life | 10,000,000 cycles | 10,000,000 cycles |
| Material | | |
| Bottom | PC | PC |
| Front | PC | PC |
| Top | PC | PC |
| Connection type | Screw terminal | Cage clamp terminal |
| Mounting type | plug-in | plug-in |
| Conductor cross section with screw terminals | | |
| 1 core flexible | 0,25 - 2,5 mm², 24 - 12 AWG | – |
| 2 core with the same cross section, flexible with crimp connectors, no plastic sleeve | 0,25 - 1 mm², 24 - 16 AWG | – |
| 2 core with the same cross section, flexible without crimp connectors or with TWIN crimp connectors | 0,2 - 1,5 mm², 24 - 16 AWG | – |
| Torque setting with screw terminals | 0,5 Nm | – |
| Conductor cross section with spring-loaded terminals: Flexible with/without crimp connector | | |
| | – | 0,2 - 2,5 mm², 24 - 12 AWG |
| Spring-loaded terminals: Terminal points per connection | | |
| | – | 2 |
| Stripping length with spring-loaded terminals | | |
| | – | 9 mm |

Safety relays PNOZsigma PNOZ s7.2

| Mechanical data | 750177 | 751177 |
|-----------------|---------|---------|
| Dimensions | | |
| Height | 98 mm | 100 mm |
| Width | 17,5 mm | 17,5 mm |
| Depth | 120 mm | 120 mm |
| Weight | 170 g | 170 g |

Where standards are undated, the 2014-07 latest editions shall apply.

Safety characteristic data

| Operating Mode | EN ISO 13849-1: 2015 | EN ISO 13849-1: 2015 | EN 62061 SIL CL | EN 62061 PFH _D [1/h] | IEC 61511 SIL | IEC 61511 PFD | EN ISO 13849-1: 2015 |
|--------------------------------|----------------------|----------------------|-----------------|---------------------------------|---------------|---------------|-----------------------|
| | PL | Category | | | | | T _M [year] |
| Safety contacts, instantaneous | PL e | Cat. 4 | SIL CL 3 | 2,31E-09 | SIL 3 | 2,03E-06 | 20 |

All the units used within a safety function must be considered when calculating the safety characteristic data.

Supplementary data

The PFH value depends on the switching frequency and the load on the relay output. If the service life graphs are not accessible, the stated PFH value can be used irrespective of the switching frequency and the load, as the PFH value already considers the relay's B10d value as well as the failure rates of the other components.

Safety relays PNOZsigma PNOZ s7.2

Service life graph

The service life graphs indicate the number of cycles from which failures due to wear must be expected. The wear is mainly caused by the electrical load; the mechanical load is negligible.

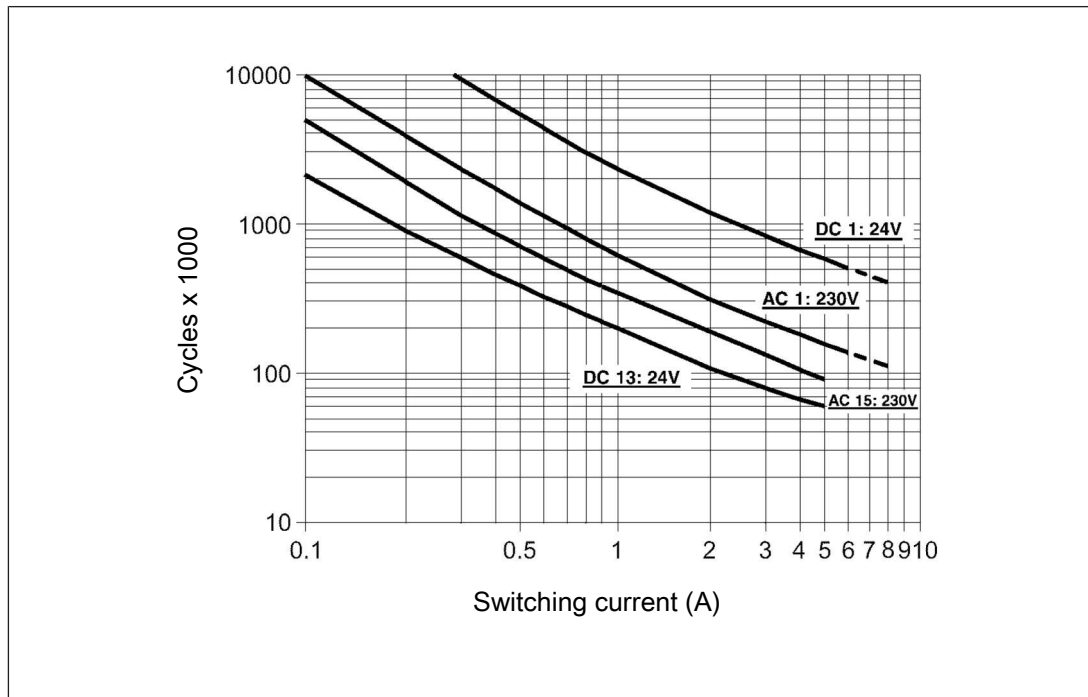

Fig.: Service life graphs at 24 V DC and 230 V AC

Safety relays PNOZsigma PNOZ s7.2

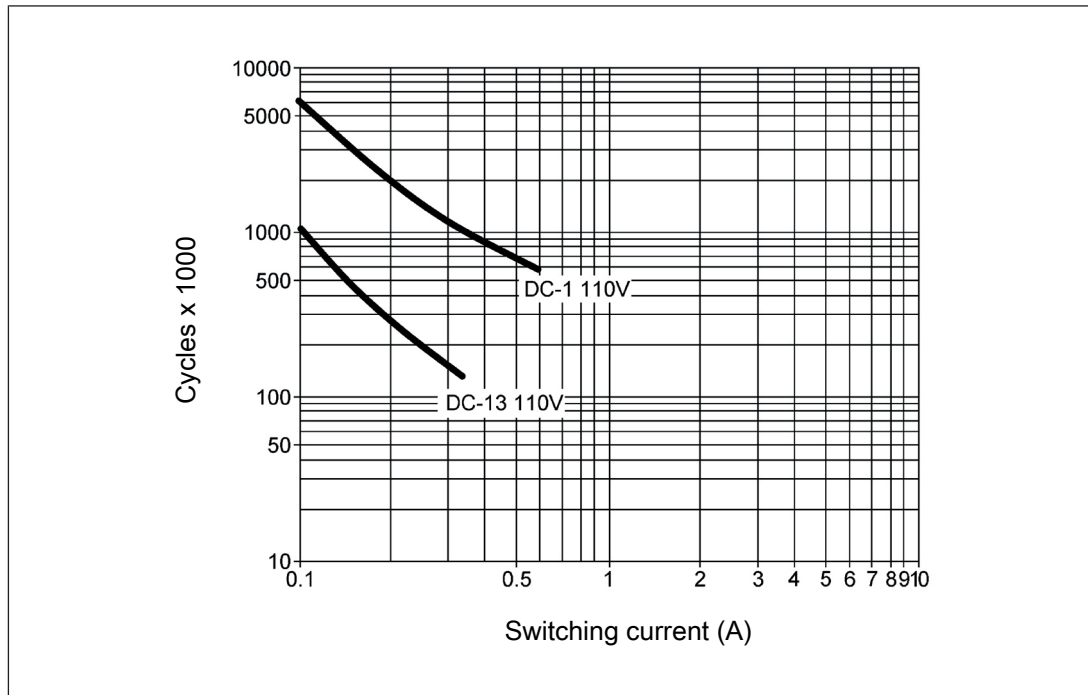

Fig.: Service life graphs at 110 V DC

Example

- ▶ Inductive load: 0.2 A
- ▶ Utilisation category: AC15
- ▶ Contact service life: 2 000 000 cycles

Provided the application to be implemented requires fewer than 2 000 000 cycles, the PFH value (see [Technical details \[735\]](#)) can be used in the calculation.

To increase the service life, sufficient spark suppression must be provided on all output contacts. With capacitive loads, any power surges that occur must be noted. With DC contactors, use flywheel diodes for spark suppression.

Order reference

| Product type | Features | Connection type | Order No. |
|--------------|----------|-------------------------|-----------|
| PNOZ s7.2 | 24 VDC | Screw terminals | 750 177 |
| PNOZ s7.2 C | 24 VDC | Spring-loaded terminals | 751 177 |

Safety relays PNOZsigma PNOZ s8

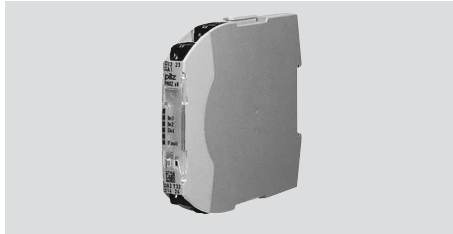

Unit features

- ▶ Relay outputs:
 - 2 safety contacts (N/O), instantaneous
- ▶ 1 semiconductor output
- ▶ LED for:
 - Input status, channel 1
 - Input status, channel 2
 - Switch status of the safety contacts
 - Fault
- ▶ Plug-in connection terminals (either spring-loaded terminal or screw terminal)
- ▶ See order reference for unit types

Safety relays PNOZsigma PNOZ s8

Block diagram/terminal configuration

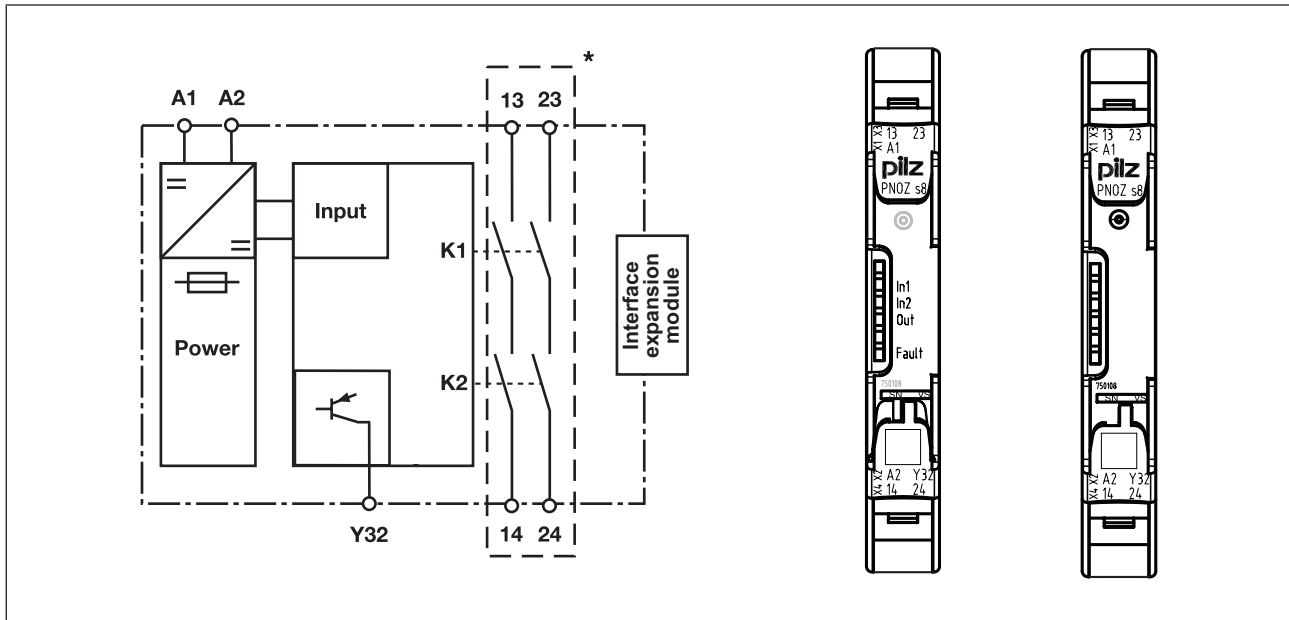

Fig.: Centre: Front view with cover, right: Front view without cover

*Safe separation from non-marked area in accordance with EN 60947-1, 6 kV, basic insulation between all safety contacts.

Function description

with PNOZsigma base unit:

- ▶ Dual-channel operation via PNOZsigma connector

without PNOZsigma base unit:

- ▶ Single-channel operation: one input circuit affects the output relays

Safety relays PNOZsigma PNOZ s8

Timing diagram

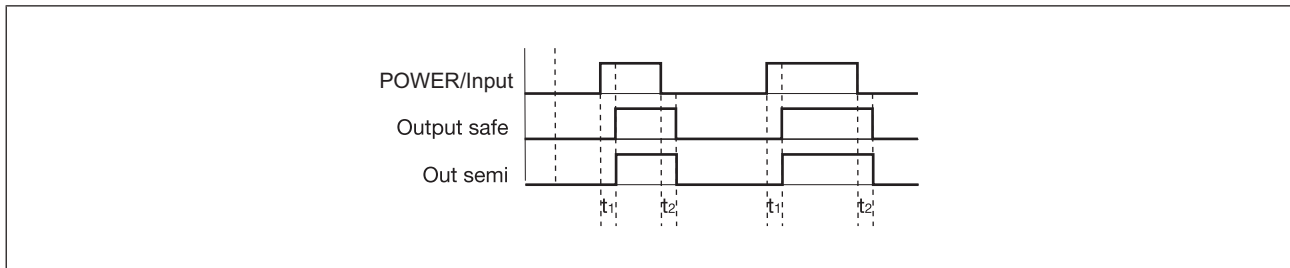

Legend

- ▶ POWER/Input: Supply voltage/input
- ▶ Output safe: Safety contacts
- ▶ Out semi: Semiconductor output
- ▶ t_1 : Switch-on delay
- ▶ t_2 : Delay-on de-energisation

Installation

Install contact expansion module without base unit:

- ▶ Ensure that the plug terminator is inserted at the side of the unit.

Connect base unit and PNOZsigma contact expansion module:

- ▶ Remove the plug terminator at the side of the base unit and at the contact expander module
- ▶ Connect the base unit and the contact expansion module using the connector supplied, before mounting the units to the DIN rail.

Control cabinet installation

- ▶ The safety relay should be installed in a control cabinet with a protection type of at least IP54.
- ▶ Use the notch on the rear of the unit to attach it to a DIN rail (35 mm).
- ▶ When installed vertically: Secure the unit by using a fixing element (e.g. retaining bracket or end angle).
- ▶ Push the unit upwards or downwards before lifting it from the DIN rail.

Safety relays PNOZsigma PNOZ s8

Wiring

Please note:

- ▶ Information given in the "[Technical details \[747\]](#)" must be followed.
- ▶ Outputs 13-14 and 23-24 are safety contacts, the semiconductor output Y32 is an auxiliary output (e.g. for display).
- ▶ Semiconductor output Y32 should **not** be used for safety circuits!
- ▶ To prevent contact welding, a fuse should be connected before the output contacts (see [Technical details \[747\]](#)).
- ▶ Calculation of the max. cable length l_{max} in the input circuit:

$$l_{max} = \frac{R_{lmax}}{R_i / km}$$

R_{lmax} = max. overall cable resistance (see [Technical details \[747\]](#))

R_i / km = cable resistance/km

- ▶ Use copper wire that can withstand 60/75 °C.
- ▶ Sufficient fuse protection must be provided on all output contacts with capacitive and inductive loads.
- ▶ Ensure the wiring and EMC requirements of IEC 60204-1 are met.
- ▶ The power supply must comply with the regulations for extra low voltages with protective electrical separation (SELV, PELV) in accordance with VDE 0100, Part 410.

Preparing for operation

| Supply voltage | AC | DC |
|---|----------------|--------------|
| | | |
| Input circuit | Single-channel | Dual-channel |
| Base unit: Safety relay PNOZ X | | |
| Base unit: Safety relay PNOZelog Driven via semiconductor outputs (24 VDC) | | |

Safety relays PNOZsigma PNOZ s8

Feedback loop

▶ **with PNOZsigma base unit:**

The feedback loop is connected and evaluated via the connector.

▶ **without PNOZsigma base unit:**

Feedback loop does not need to be monitored because the contact expansion block monitors its own output contacts.

Semiconductor output

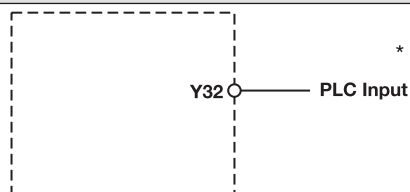

*Connect together the 0V connections on all the external power supplies

Dimensions in mm

*with spring-loaded terminals

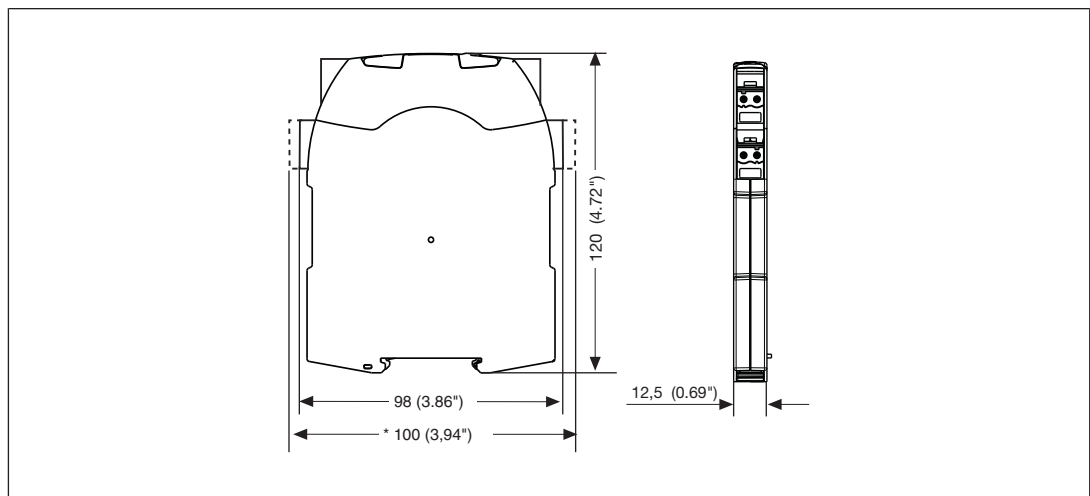

Safety relays PNOZsigma PNOZ s8

Technical details

| General | 750108 | 751108 |
|---|--|--|
| Approvals | CCC, CE, EAC (Eurasian), KOSHA, TÜV, cULus Listed | CCC, CE, EAC (Eurasian), KOSHA, TÜV, cULus Listed |
| Electrical data | 750108 | 751108 |
| Supply voltage | | |
| Voltage | 24 V | 24 V |
| Kind | DC | DC |
| Voltage tolerance | -20 %/+20 % | -20 %/+20 % |
| Output of external power supply (DC) | 2 W | 2 W |
| Residual ripple DC | 20 % | 20 % |
| Duty cycle | 100 % | 100 % |
| Inputs | 750108 | 751108 |
| Number | 1 | 1 |
| Voltage at | | |
| Input circuit DC | 24 V | 24 V |
| Current at | | |
| Input circuit DC | 65 mA | 65 mA |
| Max. inrush current impulse | | |
| Current pulse, input circuit | 0,6 A | 0,6 A |
| Pulse duration, input circuit | 15 ms | 15 ms |
| Max. overall cable resistance RI- max | | |
| Single-channel at UB DC | 30 Ohm | 30 Ohm |
| Semiconductor outputs | 750108 | 751108 |
| Number | 1 | 1 |
| Voltage | 24 V | 24 V |
| Current | 20 mA | 20 mA |
| Relay outputs | 750108 | 751108 |
| Number of output contacts | | |
| Safety contacts (N/O), instant- aneous | 2 | 2 |
| Max. short circuit current IK | 1 kA | 1 kA |
| Utilisation category | | |
| In accordance with the standard | EN 60947-4-1 | EN 60947-4-1 |

Safety relays PNOZsigma PNOZ s8

| Relay outputs | 750108 | 751108 |
|---|----------------|----------------|
| Utilisation category of safety contacts | | |
| AC1 at | 240 V | 240 V |
| Min. current | 0,02 A | 0,02 A |
| Max. current | 3 A | 3 A |
| Max. power | 720 VA | 720 VA |
| DC1 at | 24 V | 24 V |
| Min. current | 0,02 A | 0,02 A |
| Max. current | 3 A | 3 A |
| Max. power | 72 W | 72 W |
| Utilisation category | | |
| In accordance with the standard | EN 60947-5-1 | EN 60947-5-1 |
| Utilisation category of safety contacts | | |
| AC15 at | 230 V | 230 V |
| Max. current | 1,5 A | 1,5 A |
| DC13 (6 cycles/min) at | 24 V | 24 V |
| Max. current | 1,5 A | 1,5 A |
| Utilisation category in accordance with UL | | |
| Voltage | 240 V AC G. P. | 240 V AC G. P. |
| With current | 3 A | 3 A |
| Voltage | 24 V DC G. P. | 24 V DC G. P. |
| With current | 3 A | 3 A |
| Pilot Duty | B300, R300 | B300, R300 |
| External contact fuse protection, safety contacts | | |
| In accordance with the standard | EN 60947-5-1 | EN 60947-5-1 |
| Blow-out fuse, quick | 4 A | 4 A |
| Blow-out fuse, slow | 2 A | 2 A |
| Blow-out fuse, gG | 4 A | 4 A |
| Circuit breaker 24V AC/DC, characteristic B/C | 2 A | 2 A |
| Conventional thermal current | 3 A | 3 A |
| Contact material | AgSnO2 | AgSnO2 |
| Times | 750108 | 751108 |
| Switch-on delay | | |
| With automatic start after power on typ. | 100 ms | 100 ms |
| With automatic start after power on max. | 150 ms | 150 ms |

Safety relays PNOZsigma PNOZ s8

| Times | 750108 | 751108 |
|--------------------------------------|--|--|
| Delay-on de-energisation | | |
| With E-STOP typ. | 30 ms | 30 ms |
| With E-STOP max. | 40 ms | 40 ms |
| With power failure typ. | 30 ms | 30 ms |
| With power failure max. | 40 ms | 40 ms |
| Environmental data | 750108 | 751108 |
| Climatic suitability | EN 60068-2-78 | EN 60068-2-78 |
| Ambient temperature | | |
| Temperature range | -10 - 55 °C | -10 - 55 °C |
| Storage temperature | | |
| Temperature range | -40 - 85 °C | -40 - 85 °C |
| Climatic suitability | | |
| Humidity | 93 % r. h. at 40 °C | 93 % r. h. at 40 °C |
| Condensation during operation | Not permitted | Not permitted |
| EMC | EN 60947-5-1, EN 61000-6-2, EN 61000-6-4, EN 61326-3-1 | EN 60947-5-1, EN 61000-6-2, EN 61000-6-4, EN 61326-3-1 |
| Vibration | | |
| In accordance with the standard | EN 60068-2-6 | EN 60068-2-6 |
| Frequency | 10 - 55 Hz | 10 - 55 Hz |
| Amplitude | 0,35 mm | 0,35 mm |
| Airgap creepage | | |
| In accordance with the standard | EN 60947-1 | EN 60947-1 |
| Overvoltage category | III / II | III / II |
| Pollution degree | 2 | 2 |
| Rated insulation voltage | 250 V | 250 V |
| Rated impulse withstand voltage | 4 kV | 4 kV |
| Protection type | | |
| Mounting area (e.g. control cabinet) | IP54 | IP54 |
| Housing | IP40 | IP40 |
| Terminals | IP20 | IP20 |
| Mechanical data | 750108 | 751108 |
| Mounting position | Any | Any |
| Mechanical life | 5,000,000 cycles | 5,000,000 cycles |
| Material | | |
| Bottom | PC | PC |
| Front | PC | PC |
| Top | PC | PC |
| Connection type | Screw terminal | Spring-loaded terminal |
| Mounting type | plug-in | plug-in |

Safety relays PNOZsigma PNOZ s8

| Mechanical data | 750108 | 751108 |
|---|--|---|
| Conductor cross section with screw terminals | | |
| 1 core flexible | 0,25 - 2,5 mm ² , 24 - 12 AWG | – |
| 2 core with the same cross section, flexible with crimp connectors, no plastic sleeve | 0,25 - 1 mm ² , 24 - 16 AWG | – |
| 2 core with the same cross section, flexible without crimp connectors or with TWIN crimp connectors | 0,2 - 1,5 mm ² , 24 - 16 AWG | – |
| Torque setting with screw terminals | 0,5 Nm | – |
| Conductor cross section with spring-loaded terminals: Flexible with/without crimp connector | – | 0,2 - 2,5 mm ² , 24 - 12 AWG |
| Spring-loaded terminals: Terminal points per connection | – | 2 |
| Stripping length with spring-loaded terminals | – | 9 mm |
| Dimensions | | |
| Height | 98 mm | 100 mm |
| Width | 12,5 mm | 12,5 mm |
| Depth | 120 mm | 120 mm |
| Weight | 105 g | 105 g |

Where standards are undated, the 2014-07 latest editions shall apply.

Safety characteristic data

| Operating Mode | EN ISO 13849-1: 2015 | EN ISO 13849-1: 2015 | EN 62061 SIL CL | EN 62061 PFH _D [1/h] | IEC 61511 SIL | IEC 61511 PFD | EN ISO 13849-1: 2015 T _M [year] |
|--------------------------------|----------------------|----------------------|-----------------|---------------------------------|---------------|---------------|--|
| | PL | Category | | | | | |
| Safety contacts, instantaneous | PL c | Cat. 3 | SIL CL 2 | 2,00E-07 | SIL 2 | 6,35E-03 | 20 |

All the units used within a safety function must be considered when calculating the safety characteristic data.

Safety relays PNOZsigma PNOZ s8

Supplementary data

The PFH value depends on the switching frequency and the load on the relay output. If the values in the service life table are not accessible, the stated PFH value can be used irrespective of the switching frequency and the load, as the PFH value already considers the relay's B10d value as well as the failure rates of the other components.

Service life table

The service life table indicates the number of cycles from which failures due to wear must be expected. The wear is mainly caused by the electrical load; the mechanical load is negligible.

| Load type | Switching current | Number of cycles |
|-----------|-------------------|------------------|
| DC1 | 3 A | 200,000 |
| DC13 | 1.5 A | 75,000 |
| AC1 | 3 A | 50,000 |
| AC15 | 1.5 A | 50,000 |

Order reference

| Product type | Features | Connection type | Order No. |
|--------------|----------|-------------------------|-----------|
| PNOZ s8 | 24 VDC | Screw terminals | 750 108 |
| PNOZ s8 C | 24 VDC | Spring-loaded terminals | 751 108 |

Safety relays PNOZsigma PNOZ s9



Unit features

- ▶ Positive-guided relay outputs, either instantaneous, delay-on de-energisation (also retriggerable), pulsing or delay-on energisation:
 - 3 safety contacts
 - 1 auxiliary contact
- ▶ Switch-on time, pulse time or delay-on de-energisation selectable with rotary switches
- ▶ LED indicator for:
 - Supply voltage
 - Input status, channel 1
 - Input status, channel 2
 - Switch status channel 1/2
 - Start circuit
 - Error
- ▶ Plug-in connection terminals (either spring-loaded terminal or screw terminal)
- ▶ See order reference for unit types

Safety relays PNOZsigma PNOZ s9

Block diagram/terminal configuration

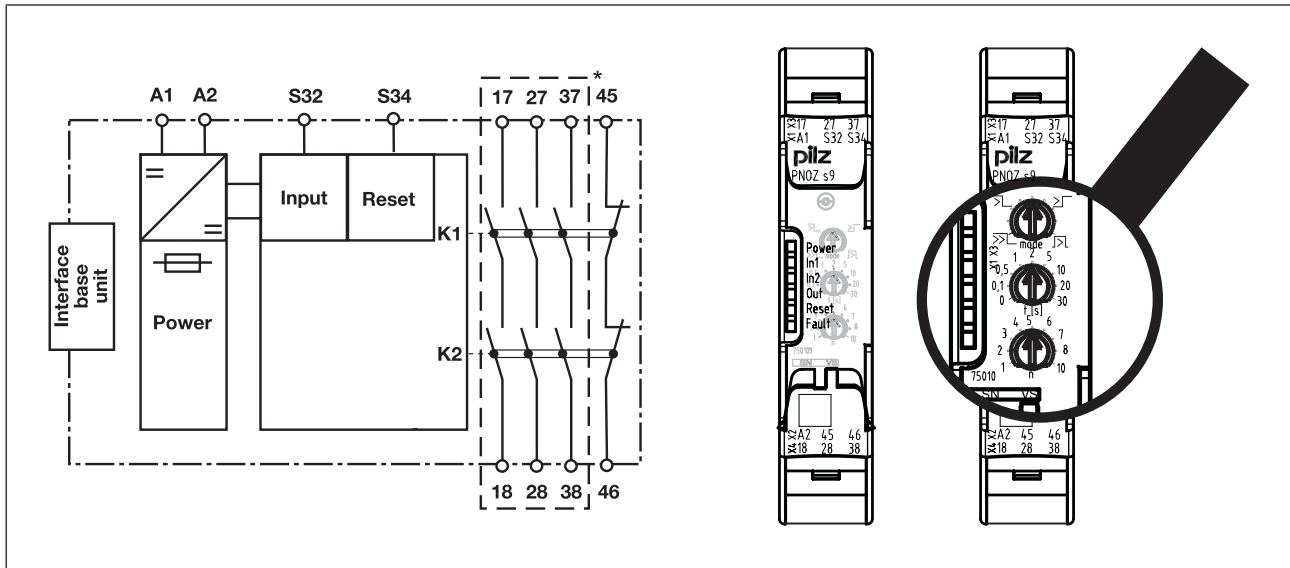

Fig.: Centre: Front view with cover, right: Front view without cover

*Safe separation from non-marked area in accordance with EN 60947-1, 6 kV, basic insulation between all safety contacts.

Function description

- ▶ Delay-on de-energisation, not retriggerable
If the supply voltage at the input circuit is interrupted, the safety contacts will open once the set release time has elapsed, even if the safety function is cancelled during the delay time. The unit cannot be reactivated until the delay time has elapsed.
- ▶ Delay-on de-energisation, retriggerable
(only possible as a standalone application or with the PNOZsigma base unit!)
If the supply voltage at the input circuit is interrupted, the safety contacts will open once the set release time has elapsed.
If the safety function is cancelled during the delay time (e.g. safety gate closed), the unit will remain active.
- ▶ Pulse on switching on
The safety contacts close when supply voltage is applied, the feedback loop is closed and finally the input circuit is closed. The safety contacts are reopened once the pulse time has elapsed.
If the input circuit is opened for more than 10 ms during the pulse time, the safety contacts will open immediately and the auxiliary contact will be closed.

Safety relays PNOZsigma PNOZ s9

- ▶ Σ Delay-on energisation
The set delay time is started when supply voltage is applied, the feedback loop is closed and finally the input circuit is closed.
If the input circuit and feedback loop are closed once the delay time has elapsed, the safety contacts will close and the auxiliary contact will be opened.
If the input circuit is opened for more than 10 ms, the safety contacts will open immediately and the auxiliary contact will be closed.

with PNOZsigma base unit:

- ▶ Dual-channel operation via PNOZsigma connector

with other base units or without base unit:

- ▶ Single-channel operation: one input circuit affects the output relays

Timing diagrams

Delay-on de-energisation, not retriggerable

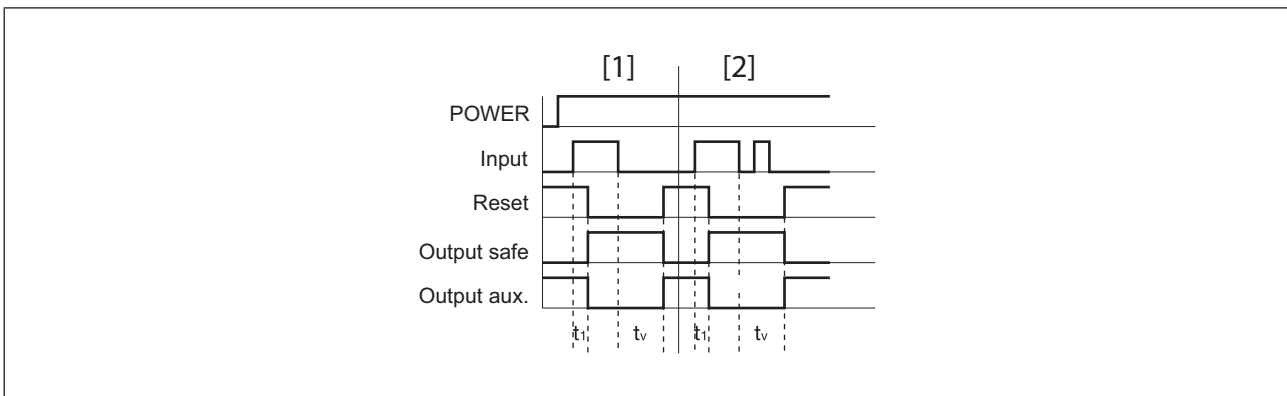

Legend

- ▶ POWER: Supply voltage
- ▶ Input: Input circuit
- ▶ Output safe: Safety contacts
- ▶ Output aux: Auxiliary contact
- ▶ Reset: Feedback loop input
- ▶ t_i : Switch-on delay
- ▶ t_v : Delay time
- ▶ [1]: Delay-on de-energisation with the time t_v
- ▶ [2]: No retriggering in the time t_v

Safety relays PNOZsigma PNOZ s9

Delay-on de-energisation, retriggerable

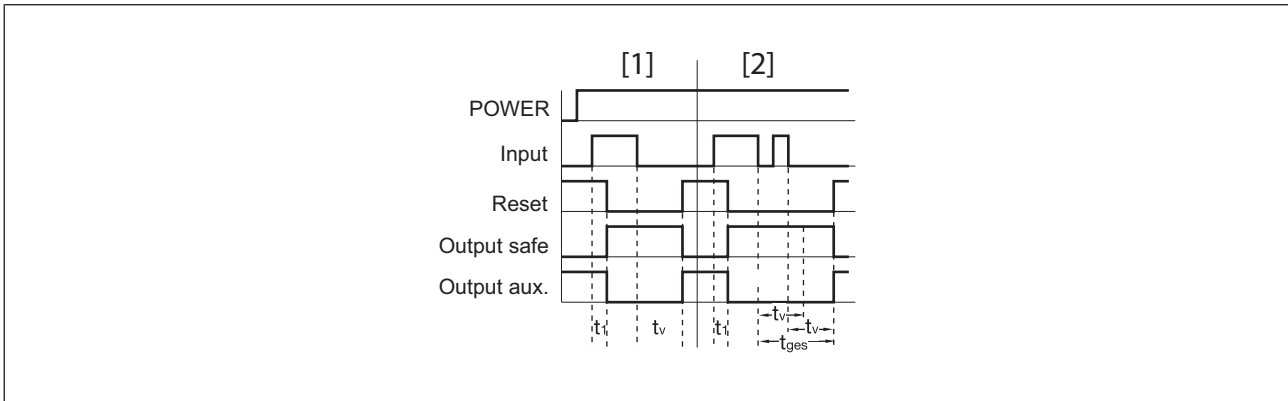

Legend

- ▶ POWER: Supply voltage
- ▶ Input: Input circuit
- ▶ Output safe: Safety contacts
- ▶ Output aux.: Auxiliary contact
- ▶ Reset: Feedback loop input
- ▶ t_i : Switch-on delay
- ▶ t_v : Delay time
- ▶ t_{ges} : Overall delay time
- ▶ [1]: Delay-on de-energisation with the time t_v
- ▶ [2]: Retriggering in the time t_v for overall delay-on de-energisation t_{ges}

Safety relays PNOZsigma PNOZ s9

Pulse on switching on

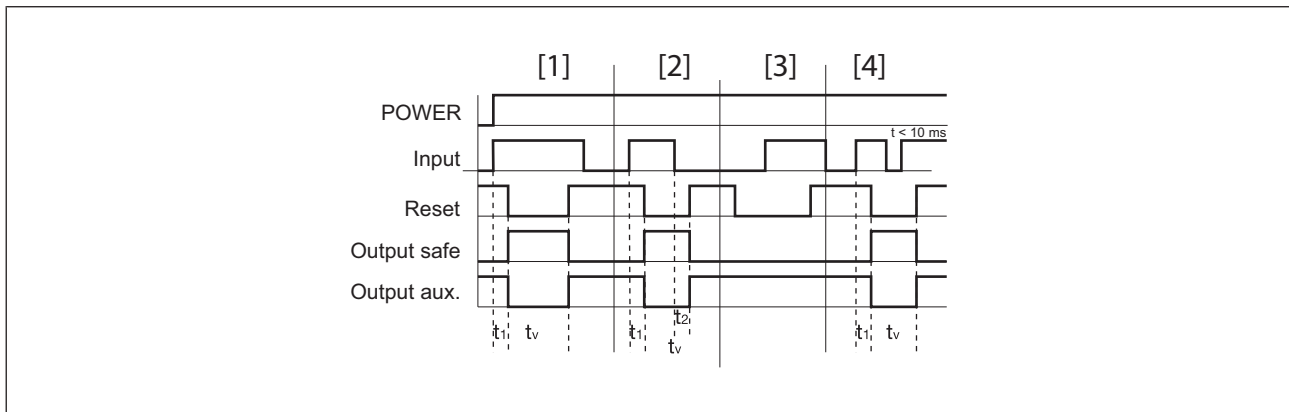

Legend

- ▶ POWER: Supply voltage
- ▶ Input: Input circuit
- ▶ Output safe: Safety contacts
- ▶ Output aux: Auxiliary contact
- ▶ Reset: Feedback loop input
- ▶ t_1 : Switch-on delay
- ▶ t_2 : Delay-on de-energisation
- ▶ t_v : Delay time (pulse time)
- ▶ [1]: Normal operating cycle
- ▶ [2]: Fault: Input circuit opened too early
- ▶ [3]: Fault: Feedback loop closed too late
- ▶ [4]: Normal operating cycle with supply interruption < 10 ms

Safety relays PNOZsigma PNOZ s9

Delay-on energisation

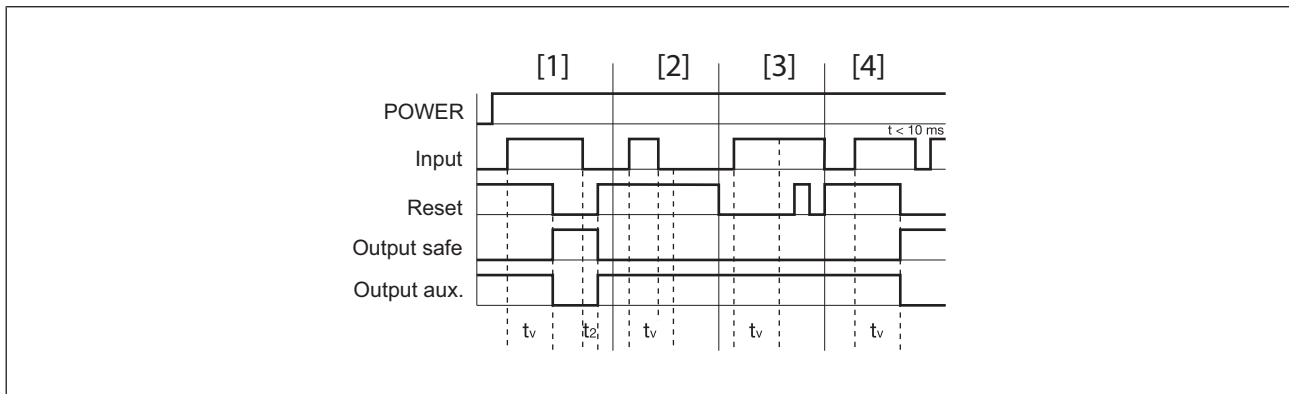

Legend

- ▶ POWER: Supply voltage
- ▶ Input: Input circuit
- ▶ Output safe: Safety contacts
- ▶ Output aux: Auxiliary contact
- ▶ Reset: Feedback loop input
- ▶ t_2 : Delay-on de-energisation
- ▶ t_v : Delay time
- ▶ [1]: Normal operating cycle
- ▶ [2]: Fault: Input circuit opened too early, before t_v expired
- ▶ [3]: Fault: Feedback loop closed too late after t_v elapsed
- ▶ [4]: Normal operating cycle with supply interruption < 10 ms

Installation

Install contact expansion module without base unit:

- ▶ Ensure that the plug terminator is inserted at the side of the unit.

Connect base unit and PNOZsigma contact expansion module:

- ▶ Remove the plug terminator at the side of the base unit and at the contact expander module
- ▶ Connect the base unit and the contact expansion module using the connector supplied, before mounting the units to the DIN rail.

Control cabinet installation

- ▶ The safety relay should be installed in a control cabinet with a protection type of at least IP54.
- ▶ Use the notch on the rear of the unit to attach it to a DIN rail (35 mm).
- ▶ When installed vertically: Secure the unit by using a fixing element (e.g. retaining bracket or end angle).

Safety relays PNOZsigma PNOZ s9

- ▶ Push the unit upwards or downwards before lifting it from the DIN rail.

Wiring

Please note:

- ▶ Information given in the "[Technical details \[761\]](#)" must be followed.
- ▶ Outputs 17-18, 27-28, 37-38 are safety contacts; output 45-46 is an auxiliary contact (e.g. for display).
- ▶ Auxiliary contact 45-46 should **not** be used for safety circuits!
- ▶ To prevent contact welding, a fuse should be connected before the output contacts (see [Technical details \[761\]](#)).
- ▶ Calculation of the max. cable length l_{max} in the input circuit:

$$l_{max} = \frac{R_{lmax}}{R_l / km}$$

R_{lmax} = max. overall cable resistance (see [Technical details \[761\]](#))

R_l / km = cable resistance/km

- ▶ Use copper wire that can withstand 60/75 °C.
- ▶ Sufficient fuse protection must be provided on all output contacts with capacitive and inductive loads.
- ▶ Ensure the wiring and EMC requirements of IEC 60204-1 are met.
- ▶ The power supply must comply with the regulations for extra low voltages with protective electrical separation (SELV, PELV) in accordance with VDE 0100, Part 410.





Preparing for operation

Operating modes and delay time

The operating mode and delay time are set via the rotary switches on the unit. You can do this by opening the cover on the front of the unit.

Set operating modes

- ▶ Switch off supply voltage.
- ▶ Select operating mode via the operating mode selector switch "mode".
- ▶ If the operating mode selector switch "mode" is in its start position (vertical position), an error message will appear.

| operating mode selector switch "mode" | delay-on de-energisation, not retriggerable | delay-on de-energisation, retriggerable | delay-on energisation | pulse on switching on |
|---------------------------------------|---|---|---|---|
| |  |  |  |  |

Safety relays PNOZsigma PNOZ s9

Set delay time

Time selector switch "t[s]"

Factor selector switch "n"

$n \times t[s] = \text{Delay time}$

Example:

$t = 4 \text{ s}, n = 5$

Delay time = $5 \times 4 = 20 \text{ s}$

Connection

- Supply voltage

| Supply voltage | AC | DC |
|----------------|----|----|
| | | |

- 1-channel input circuit/feedback loop

| Input circuit | Input circuit | Feedback loop |
|--|---------------|---------------|
| Without base unit (stand-alone) | | |
| Base unit: Safety relay PNOZ X | | |
| Base unit: Safety relay PNOZelog; driven via semiconductor outputs (24 VDC) | | |

Safety relays PNOZsigma PNOZ s9

▶ 2-channel input circuit

| | | |
|---|---|---|
| | Base unit: Safety relays PNOZ s3, PNOZ s4, PNOZ s5 | Base unit: Safety relays PNOZ s1, PNOZ s2 |
| The input circuit is connected and evaluated via the connector. | | |
| | Base unit: Two-hand control device PNOZ s6 | Base unit: Two-hand control device PNOZ s6.1 |
| The input circuit is connected and evaluated via the connector. | | |

▶ Application

| | | |
|-------------------|------------------------------|---------------------------|
| | Without feedback loop | With feedback loop |
| Without base unit | | |

Legend

- ▶ S3: Start button

Dimensions in mm

*with spring-loaded terminals

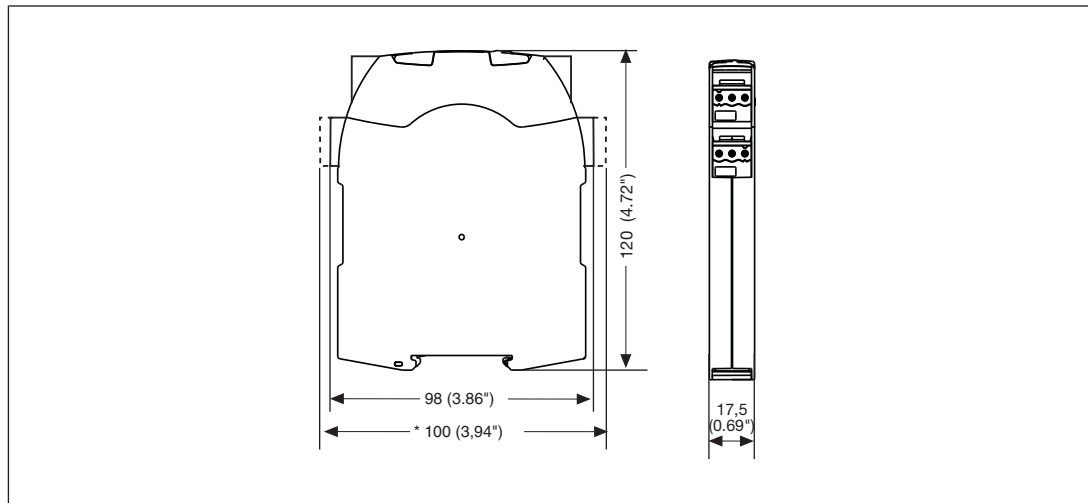

Safety relays PNOZsigma PNOZ s9

Technical details

| General | 750109 | 751109 | 751189 |
|---|---|---|---|
| Approvals | CCC, CE, EAC (Eurasian), KOSHA, TÜV, cULus Listed | CCC, CE, EAC (Eurasian), KOSHA, TÜV, cULus Listed | CCC, CE, EAC (Eurasian), KOSHA, TÜV, cULus Listed |
| Electrical data | 750109 | 751109 | 751189 |
| Supply voltage | | | |
| Voltage | 24 V | 24 V | 24 V |
| Kind | DC | DC | DC |
| Voltage tolerance | -20 %/+20 % | -20 %/+20 % | -20 %/+20 % |
| Output of external power supply (DC) | 2 W | 2 W | 2 W |
| Residual ripple DC | 20 % | 20 % | 20 % |
| Duty cycle | 100 % | 100 % | 100 % |
| Max. inrush current impulse | | | |
| Current pulse, A1 | 0,7 A | 0,7 A | 0,7 A |
| Pulse duration, A1 | 10 ms | 10 ms | 10 ms |
| Max. overall cable resistance R _{lmax} | | | |
| Feedback loop | 30 Ohm | 30 Ohm | 30 Ohm |
| A1/A2 | 20 Ohm | 20 Ohm | 20 Ohm |
| Inputs | 750109 | 751109 | 751189 |
| Voltage at | | | |
| Feedback loop DC | 24 V | 24 V | 24 V |
| Current at | | | |
| Input circuit DC | 15 mA | 15 mA | 15 mA |
| Feedback loop DC | 15 mA | 15 mA | 15 mA |
| Max. inrush current impulse | | | |
| Current pulse, input circuit | 0,1 A | 0,1 A | 0,1 A |
| Pulse duration, input circuit | 20 µs | 20 µs | 20 µs |
| Current pulse, feedback loop | 0,1 A | 0,1 A | 0,1 A |
| Pulse duration, feedback loop | 20 µs | 20 µs | 20 µs |
| Max. overall cable resistance R _{lmax} | | | |
| Single-channel at UB DC | 30 Ohm | 30 Ohm | 30 Ohm |

Safety relays PNOZsigma PNOZ s9

| Relay outputs | 750109 | 751109 | 751189 |
|--|--------------|--------------|--------------|
| Number of output contacts | | | |
| Safety contacts (N/O), delayed | 3 | 3 | 3 |
| Auxiliary contacts (N/C), delayed | 1 | 1 | 1 |
| Max. short circuit current IK | 1 kA | 1 kA | 1 kA |
| Utilisation category | | | |
| In accordance with the standard | EN 60947-4-1 | EN 60947-4-1 | EN 60947-4-1 |
| Utilisation category of safety contacts | | | |
| AC1 at | 240 V | 240 V | 240 V |
| Min. current | 0,01 A | 0,01 A | 0,01 A |
| Max. current | 6 A | 6 A | 6 A |
| Max. power | 1500 VA | 1500 VA | 1500 VA |
| DC1 at | 24 V | 24 V | 24 V |
| Min. current | 0,01 A | 0,01 A | 0,01 A |
| Max. current | 6 A | 6 A | 6 A |
| Max. power | 150 W | 150 W | 150 W |
| Utilisation category of auxiliary contacts | | | |
| AC1 at | 240 V | 240 V | 240 V |
| Min. current | 0,01 A | 0,01 A | 0,01 A |
| Max. current | 6 A | 6 A | 6 A |
| Max. power | 1500 VA | 1500 VA | 1500 VA |
| DC1 at | 24 V | 24 V | 24 V |
| Min. current | 0,01 A | 0,01 A | 0,01 A |
| Max. current | 6 A | 6 A | 6 A |
| Max. power | 150 W | 150 W | 150 W |
| Utilisation category | | | |
| In accordance with the standard | EN 60947-5-1 | EN 60947-5-1 | EN 60947-5-1 |
| Utilisation category of safety contacts | | | |
| AC15 at | 230 V | 230 V | 230 V |
| Max. current | 5 A | 5 A | 5 A |
| DC13 (6 cycles/min) at | 24 V | 24 V | 24 V |
| Max. current | 5 A | 5 A | 5 A |

Safety relays PNOZsigma PNOZ s9

| Relay outputs | 750109 | 751109 | 751189 |
|--|--------------------------------------|--------------------------------------|--------------------------------------|
| Utilisation category of auxiliary contacts | | | |
| AC15 at | 230 V | 230 V | 230 V |
| Max. current | 5 A | 5 A | 5 A |
| DC13 (6 cycles/min) at | 24 V | 24 V | 24 V |
| Max. current | 5 A | 5 A | 5 A |
| Utilisation category in accordance with UL | | | |
| Voltage | 240 V AC G.U. (same polarity) | 240 V AC G.U. (same polarity) | 240 V AC G.U. (same polarity) |
| With current | 6 A | 6 A | 6 A |
| Voltage | 24 V DC G. U. | 24 V DC G. U. | 24 V DC G. U. |
| With current | 6 A | 6 A | 6 A |
| External contact fuse protection, safety contacts | | | |
| In accordance with the standard | EN 60947-5-1 | EN 60947-5-1 | EN 60947-5-1 |
| Max. melting integral | 260 A²s | 260 A²s | 260 A²s |
| Blow-out fuse, quick | 10 A | 10 A | 10 A |
| Blow-out fuse, slow | 6 A | 6 A | 6 A |
| Blow-out fuse, gG | 10 A | 10 A | 10 A |
| Circuit breaker 24V AC/DC, characteristic B/C | 6 A | 6 A | 6 A |
| External contact fuse protection, auxiliary contacts | | | |
| Max. melting integral | 160 A²s | 160 A²s | 160 A²s |
| Blow-out fuse, quick | 10 A | 10 A | 10 A |
| Blow-out fuse, slow | 6 A | 6 A | 6 A |
| Blow-out fuse, gG | 6 A | 6 A | 6 A |
| Circuit breaker 24 V AC/DC, characteristic B/C | 6 A | 6 A | 6 A |
| Conventional thermal current | 6 A | 6 A | 6 A |
| Contact material | AgCuNi + 0,2 µm Au | AgCuNi + 0,2 µm Au | AgCuNi + 0,2 µm Au |
| Times | 750109 | 751109 | 751189 |
| Switch-on delay | | | |
| With manual start typ. | 60 ms | 60 ms | 60 ms |
| With manual start max. | 80 ms | 80 ms | 80 ms |
| Delay-on de-energisation | | | |
| With E-STOP typ. | 40 ms | 40 ms | 40 ms |
| With E-STOP max. | 50 ms | 50 ms | 50 ms |

Safety relays PNOZsigma PNOZ s9

| Times | 750109 | 751109 | 751189 |
|---|--|--|--|
| Recovery time at max. switching frequency 1/s | | | |
| After power failure | 800 ms | 800 ms | 800 ms |
| Delay time t_v | 0,04 s, 0,1 s, 0,2 s, 0,3 s, 0,4 s, 0,5 s, 0,6 s, 0,7 s, 0,8 s, 1 s, 1,5 s, 2 s, 2,5 s, 3 s, 3,5 s, 4 s, 5 s, 6 s, 7 s, 8 s, 10 s, 12 s, 14 s, 15 s, 16 s, 20 s, 25 s, 30 s, 35 s, 40 s, 50 s, 60 s, 70 s, 80 s, 90 s, 100 s, 120 s, 140 s, 150 s, 160 s, 180 s, 200 s, 210 s, 240 s, 300 s | 0,04 s, 0,1 s, 0,2 s, 0,3 s, 0,4 s, 0,5 s, 0,6 s, 0,7 s, 0,8 s, 1 s, 1,5 s, 2 s, 2,5 s, 3 s, 3,5 s, 4 s, 5 s, 6 s, 7 s, 8 s, 10 s, 12 s, 14 s, 15 s, 16 s, 20 s, 25 s, 30 s, 35 s, 40 s, 50 s, 60 s, 70 s, 80 s, 90 s, 100 s, 120 s, 140 s, 150 s, 160 s, 180 s, 200 s, 210 s, 240 s, 300 s | 0,04 s, 0,1 s, 0,2 s, 0,3 s, 0,4 s, 0,5 s, 0,6 s, 0,7 s, 0,8 s, 1 s, 1,5 s, 2 s, 2,5 s, 3 s, 3,5 s, 4 s, 5 s, 6 s, 7 s, 8 s, 10 s, 12 s, 14 s, 15 s, 16 s, 20 s, 25 s, 30 s, 35 s, 40 s, 50 s, 60 s, 70 s, 80 s, 90 s, 100 s, 120 s, 140 s, 150 s, 160 s, 180 s, 200 s, 210 s, 240 s, 300 s |
| Time accuracy | +/-1 % + +/-20 ms | +/-1 % + +/-20 ms | +/-1 % + +/-20 ms |
| Repetition accuracy | +/-1 % + +/-20 ms | +/-1 % + +/-20 ms | +/-1 % + +/-20 ms |
| Repetition accuracy in the event of an error | +/-15 % + +/-20 ms | +/-15 % + +/-20 ms | +/-15 % + +/-20 ms |
| Min. delay time (operating mode delay-on energisation) | $t_v - 15 \% - 20 \text{ ms}$ | $t_v - 15 \% - 20 \text{ ms}$ | $t_v - 15 \% - 20 \text{ ms}$ |
| Max. delay time | $t_v + 15 \% + 20 \text{ ms}$ | $t_v + 15 \% + 20 \text{ ms}$ | $t_v + 15 \% + 20 \text{ ms}$ |
| Supply interruption before de-energisation in the input circuit | 10 ms | 10 ms | 10 ms |
| Supply interruption before de-energisation | 10 ms | 10 ms | 10 ms |
| Environmental data | 750109 | 751109 | 751189 |
| Climatic suitability | EN 60068-2-78 | EN 60068-2-78 | EN 60068-2-78 |
| Ambient temperature | | | |
| Temperature range | -15 - 55 °C | -15 - 55 °C | -15 - 55 °C |
| Storage temperature | | | |
| Temperature range | -40 - 85 °C | -40 - 85 °C | -40 - 85 °C |
| Climatic suitability | | | |
| Humidity | 93 % r. h. at 40 °C | 93 % r. h. at 40 °C | 93 % r. h. at 40 °C |
| Condensation during operation | Not permitted | Not permitted | Not permitted |
| EMC | EN 60947-5-1, EN 61000-6-2, EN 61000-6-4, EN 61326-3-1 | EN 60947-5-1, EN 61000-6-2, EN 61000-6-4, EN 61326-3-1 | EN 60947-5-1, EN 61000-6-2, EN 61000-6-4, EN 61326-3-1 |
| Vibration | | | |
| In accordance with the standard | EN 60068-2-6 | EN 60068-2-6 | EN 60068-2-6 |
| Frequency | 10 - 55 Hz | 10 - 55 Hz | 10 - 55 Hz |
| Amplitude | 0,35 mm | 0,35 mm | 0,35 mm |

Safety relays PNOZsigma PNOZ s9

| Environmental data | 750109 | 751109 | 751189 |
|---|--|---|---|
| Airgap creepage | | | |
| In accordance with the standard | EN 60947-1 | EN 60947-1 | EN 60947-1 |
| Overvoltage category | III | III | III |
| Pollution degree | 2 | 2 | 2 |
| Rated insulation voltage | 250 V | 250 V | 250 V |
| Rated impulse withstand voltage | 6 kV | 6 kV | 6 kV |
| Protection type | | | |
| Mounting area (e.g. control cabinet) | IP54 | IP54 | IP54 |
| Housing | IP40 | IP40 | IP40 |
| Terminals | IP 20 | IP 20 | IP 20 |
| Mechanical data | 750109 | 751109 | 751189 |
| Mounting position | Any | Any | Any |
| Mechanical life | 10,000,000 cycles | 10,000,000 cycles | 10,000,000 cycles |
| Material | | | |
| Bottom | PC | PC | PC |
| Front | PC | PC | PC |
| Top | PC | PC | PC |
| Connection type | Screw terminal | Spring-loaded terminal | Spring-loaded terminal |
| Mounting type | plug-in | plug-in | plug-in |
| Conductor cross section with screw terminals | | | |
| 1 core flexible | 0,25 - 2,5 mm ² , 24 - 12 AWG | – | – |
| 2 core with the same cross section, flexible with crimp connectors, no plastic sleeve | 0,25 - 1 mm ² , 24 - 16 AWG | – | – |
| 2 core with the same cross section, flexible without crimp connectors or with TWIN crimp connectors | 0,2 - 1,5 mm ² , 24 - 16 AWG | – | – |
| Torque setting with screw terminals | 0,5 Nm | – | – |
| Conductor cross section with spring-loaded terminals: Flexible with/without crimp connector | – | 0,2 - 2,5 mm ² , 24 - 12 AWG | 0,2 - 2,5 mm ² , 24 - 12 AWG |
| Spring-loaded terminals: Terminal points per connection | – | 2 | 2 |

Safety relays PNOZsigma PNOZ s9

| Mechanical data | 750109 | 751109 | 751189 |
|---|---------|---------|---------|
| Stripping length with spring-loaded terminals | – | 9 mm | 9 mm |
| Dimensions | | | |
| Height | 98 mm | 100 mm | 100 mm |
| Width | 17,5 mm | 17,5 mm | 17,5 mm |
| Depth | 120 mm | 120 mm | 120 mm |
| Weight | 175 g | 175 g | 175 g |

Where standards are undated, the 2014-07 latest editions shall apply.

Safety characteristic data

| Operating Mode | EN ISO 13849-1: 2015 | EN ISO 13849-1: 2015 | EN 62061 SIL CL | EN 62061 PFH _D [1/h] | IEC 61511 SIL | IEC 61511 PFD | EN ISO 13849-1: 2015 T _M [year] |
|--------------------------|----------------------|----------------------|-----------------|---------------------------------|---------------|---------------|--|
| | PL | Category | | | | | |
| Safety contacts, delayed | PL e | Cat. 4 | SIL CL 3 | 2,34E-09 | SIL 3 | 2,75E-05 | 20 |

All the units used within a safety function must be considered when calculating the safety characteristic data.

Supplementary data

The PFH value depends on the switching frequency and the load on the relay output. If the service life graphs are not accessible, the stated PFH value can be used irrespective of the switching frequency and the load, as the PFH value already considers the relay's B10d value as well as the failure rates of the other components.

Safety relays PNOZsigma PNOZ s9

Service life graph

The service life graphs indicate the number of cycles from which failures due to wear must be expected. The wear is mainly caused by the electrical load; the mechanical load is negligible.

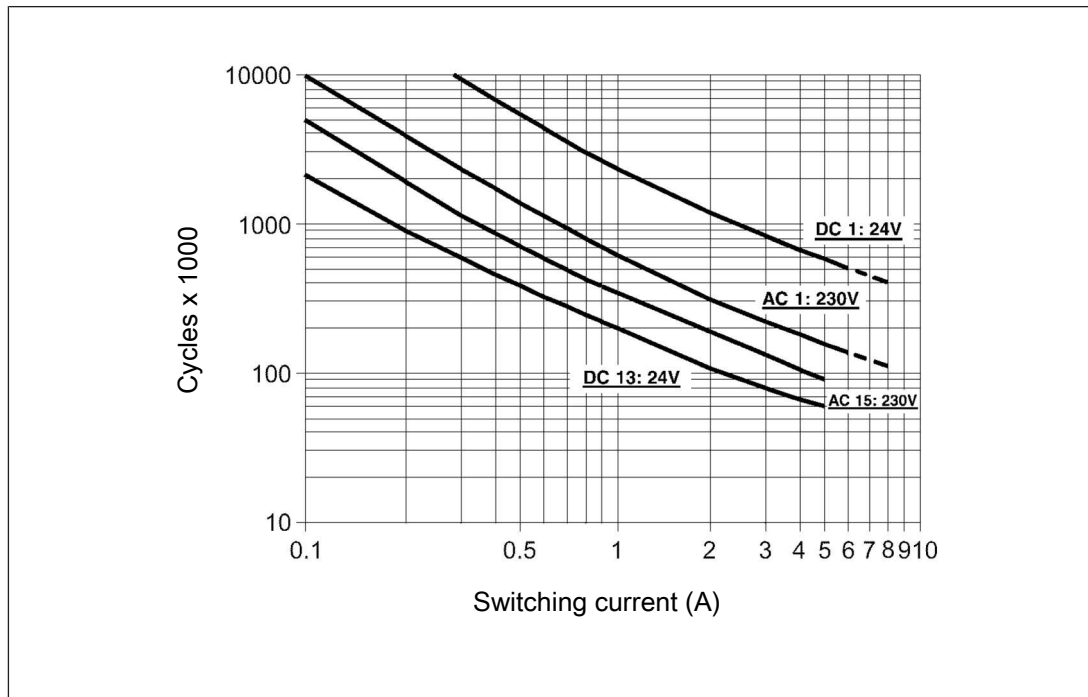

Fig.: Service life graphs at 24 V DC and 230 V AC

Safety relays PNOZsigma PNOZ s9

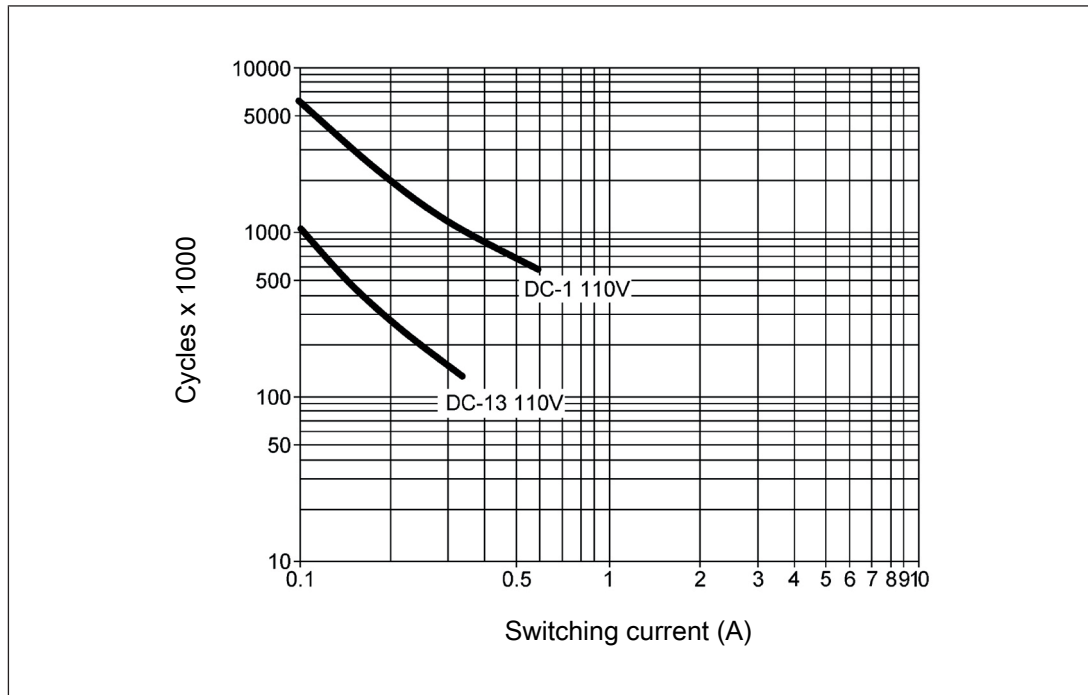

Fig.: Service life graphs at 110 V DC

Example

- ▶ Inductive load: 0.2 A
- ▶ Utilisation category: AC15
- ▶ Contact service life: 2 000 000 cycles

Provided the application to be implemented requires fewer than 2 000 000 cycles, the PFH value (see [Technical details \[761\]](#)) can be used in the calculation.

To increase the service life, sufficient spark suppression must be provided on all output contacts. With capacitive loads, any power surges that occur must be noted. With DC contactors, use flywheel diodes for spark suppression.

Order reference

| Product type | Features | Connection type | Order No. |
|-------------------------------|-------------------|-------------------------|-----------|
| PNOZ s9 | 24 VDC | Screw terminals | 750 109 |
| PNOZ s9 C | 24 VDC | Spring-loaded terminals | 751 109 |
| PNOZ s9 C (coated version) | 24 VDC | Spring-loaded terminals | 751 189 |
| PNOZ s9 C | 24 VDC; 10 pieces | Spring-loaded terminals | 751 909 |

Safety relays PNOZsigma PNOZ s10



Unit features

- ▶ Positive-guided relay outputs:
 - 4 safety contacts (N/O), instantaneous
 - 1 auxiliary contact (N/C), instantaneous
- ▶ LED for:
 - Input status, channel 1
 - Input status, channel 2
 - Switch status of the safety contacts
 - Fault
- ▶ Plug-in connection terminals (either spring-loaded terminal or screw terminal)
- ▶ See order reference for unit types

Block diagram/terminal configuration

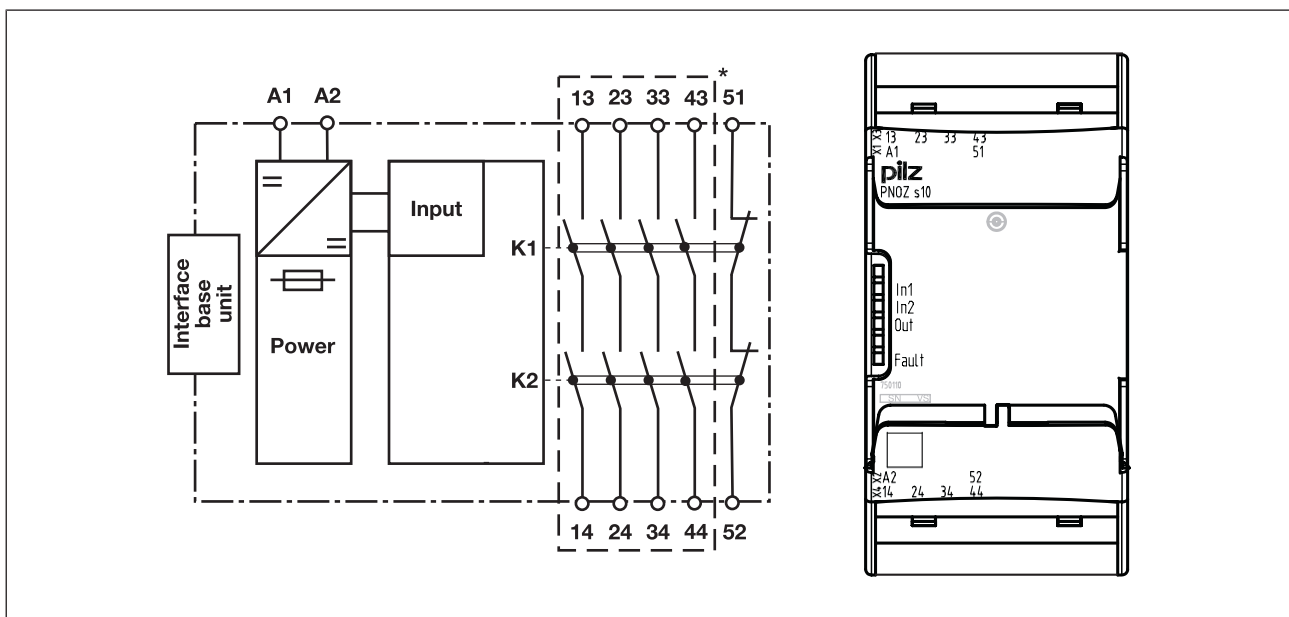

*Safe separation from non-marked area in accordance with EN 60947-1, 6 kV, basic insulation between all safety contacts.

Safety relays PNOZsigma PNOZ s10

Function description

with PNOZsigma base unit:

- ▶ Dual-channel operation via PNOZsigma connector

without PNOZsigma base unit:

- ▶ Single-channel operation: one input circuit affects the output relays

Timing diagram

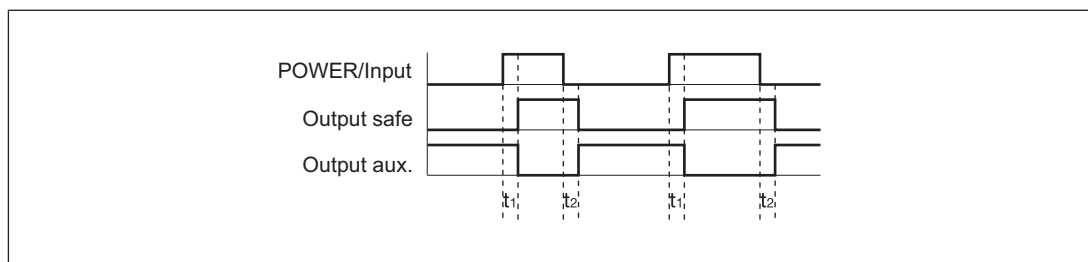

Legend

- ▶ POWER/Input: Supply voltage/input circuit
- ▶ Output safe: Safety contacts
- ▶ Output aux.: Auxiliary contacts
- ▶ t_1 : Switch-on delay
- ▶ t_2 : Delay-on de-energisation

Installation

Install contact expansion module without base unit:

- ▶ Ensure that the plug terminator is inserted at the side of the unit.

Connect base unit and PNOZsigma contact expansion module:

- ▶ Remove the plug terminator at the side of the base unit and at the contact expander module
- ▶ Connect the base unit and the contact expansion module using the connector supplied, before mounting the units to the DIN rail.

Control cabinet installation

- ▶ The safety relay should be installed in a control cabinet with a protection type of at least IP54.
- ▶ Use the notch on the rear of the unit to attach it to a DIN rail (35 mm).
- ▶ When installed vertically: Secure the unit by using a fixing element (e.g. retaining bracket or end angle).
- ▶ Push the unit upwards or downwards before lifting it from the DIN rail.

Safety relays PNOZsigma PNOZ s10

Wiring

Please note:

- ▶ Information given in the "[Technical details \[773\]](#)" must be followed.
- ▶ Outputs 13-14, 23-24, 33-34, 43-44 are safety contacts; outputs 51 -52 are auxiliary contacts (e.g. for display).
- ▶ Auxiliary contact 51-52 should **not** be used for safety circuits!
- ▶ To prevent contact welding, a fuse should be connected before the output contacts (see [Technical details \[773\]](#)).
- ▶ Calculation of the max. cable length l_{\max} in the input circuit:

$$l_{\max} = \frac{R_{l_{\max}}}{R_l / \text{km}}$$

$R_{l_{\max}}$ = max. overall cable resistance (see [Technical details \[773\]](#))

R_l / km = cable resistance/km

- ▶ Use copper wire that can withstand 60/75 °C.
- ▶ Sufficient fuse protection must be provided on all output contacts with capacitive and inductive loads.
- ▶ Do not connect undesignated terminals.
- ▶ The power supply must comply with the regulations for extra low voltages with protective electrical separation (SELV, PELV) in accordance with VDE 0100, Part 410.
- ▶ Ensure the wiring and EMC requirements of IEC 60204-1 are met.

Safety relays PNOZsigma PNOZ s10

Preparing for operation

| Supply voltage | AC | DC |
|---|-----------------------------------|--|
| | | |
| Input circuit | Single-channel | Dual-channel |
| Base unit: Safety relay PNOZ X | | |
| Base unit: Safety relay PNOZelog Driven via semiconductor outputs (24 VDC) | | |
| Feedback loop | Base unit: Safety relay PNOZ X | Base unit: Safety relay PNOZelog |
| The inputs that evaluate the feedback loop will depend on the base unit and application | | |
| Connection to PNOZsigma base unit/PNOZmulti Mini base unit | Base unit: Safety relay PNOZsigma | Base unit: Small control system PNOZmulti Mini |
| The feedback loop is connected and evaluated via the connector | | |

Safety relays PNOZsigma PNOZ s10

Dimensions in mm

*with spring-loaded terminals

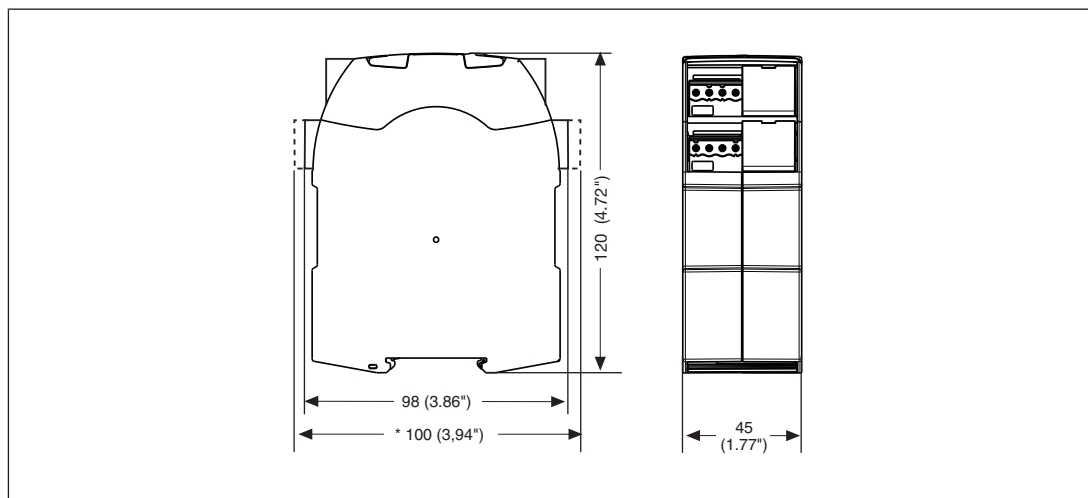

Technical details

| General | 750110 | 751110 |
|--------------------------------------|--|--|
| Approvals | CCC, CE, EAC (Eurasian), KOSHA, TÜV, cULus Listed | CCC, CE, EAC (Eurasian), KOSHA, TÜV, cULus Listed |
| Electrical data | 750110 | 751110 |
| Supply voltage | | |
| Voltage | 24 V | 24 V |
| Kind | DC | DC |
| Voltage tolerance | -20 %/+20 % | -20 %/+20 % |
| Output of external power supply (DC) | 3 W | 3 W |
| Residual ripple DC | 20 % | 20 % |
| Duty cycle | 100 % | 100 % |
| Inputs | 750110 | 751110 |
| Number | 1 | 1 |
| Voltage at | | |
| Input circuit DC | 24 V | 24 V |
| Current at | | |
| Input circuit DC | 95 mA | 95 mA |
| Max. inrush current impulse | | |
| Current pulse, input circuit | 2 A | 2 A |
| Pulse duration, input circuit | 0,1 ms | 0,1 ms |

Safety relays PNOZsigma PNOZ s10

| Inputs | 750110 | 751110 |
|--|---------------------|---------------------|
| Max. overall cable resistance RI-max | | |
| Single-channel at UB DC | 30 Ohm | 30 Ohm |
| Relay outputs | 750110 | 751110 |
| Number of output contacts | | |
| Safety contacts (N/O), instantaneous | 4 | 4 |
| Auxiliary contacts (N/C) | 1 | 1 |
| Max. short circuit current IK | 1 kA | 1 kA |
| Utilisation category | | |
| In accordance with the standard | EN 60947-4-1 | EN 60947-4-1 |
| Utilisation category of safety contacts | | |
| AC1 at | 240 V | 240 V |
| Min. current | 0,01 A | 0,01 A |
| Max. current | 12 A | 12 A |
| Max. power | 3000 VA | 3000 VA |
| DC1 at | 24 V | 24 V |
| Min. current | 0,01 A | 0,01 A |
| Max. current | 12 A | 12 A |
| Max. power | 300 W | 300 W |
| Utilisation category of auxiliary contacts | | |
| AC1 at | 240 V | 240 V |
| Min. current | 0,01 A | 0,01 A |
| Max. current | 2 A | 2 A |
| Max. power | 500 VA | 500 VA |
| DC1 at | 24 V | 24 V |
| Min. current | 0,01 A | 0,01 A |
| Max. current | 2 A | 2 A |
| Max. power | 50 W | 50 W |
| Utilisation category | | |
| In accordance with the standard | EN 60947-5-1 | EN 60947-5-1 |
| Utilisation category of safety contacts | | |
| AC15 at | 230 V | 230 V |
| Max. current | 6 A | 6 A |
| DC13 (6 cycles/min) at | 24 V | 24 V |
| Max. current | 7,5 A | 7,5 A |

Safety relays PNOZsigma PNOZ s10

| Relay outputs | 750110 | 751110 |
|--|--------------------------------|--------------------------------|
| Utilisation category of auxiliary contacts | | |
| AC15 at | 230 V | 230 V |
| Max. current | 2 A | 2 A |
| DC13 (6 cycles/min) at | 24 V | 24 V |
| Max. current | 2 A | 2 A |
| Utilisation category in accordance with UL | | |
| Voltage | 240 V AC G. P. | 240 V AC G. P. |
| With current | 12 A | 12 A |
| Voltage | 24 V DC Resistive | 24 V DC Resistive |
| With current | 12 A | 12 A |
| External contact fuse protection, safety contacts | | |
| In accordance with the standard | EN 60947-5-1 | EN 60947-5-1 |
| Max. melting integral | 640 A ² s | 640 A ² s |
| Blow-out fuse, quick | 16 A | 16 A |
| Blow-out fuse, slow | 10 A | 10 A |
| Blow-out fuse, gG | 16 A | 16 A |
| Circuit breaker 24V AC/DC, characteristic B/C | 10 A | 10 A |
| External contact fuse protection, auxiliary contacts | | |
| Max. melting integral | 240 A ² s | 240 A ² s |
| Blow-out fuse, quick | 4 A | 4 A |
| Blow-out fuse, slow | 2 A | 2 A |
| Blow-out fuse, gG | 4 A | 4 A |
| Circuit breaker 24 V AC/DC, characteristic B/C | 2 A | 2 A |
| Contact material | AgSnO ₂ + 0,2 µm Au | AgSnO ₂ + 0,2 µm Au |
| Conventional thermal current while loading several contacts | 750110 | 751110 |
| I _{th} per contact at UB DC; AC1: 240 V, DC1: 24 V | | |
| Conv. therm. current with 1 contact | 12 A | 12 A |
| Conv. therm. current with 2 contacts | 11 A | 11 A |
| Conv. therm. current with 3 contacts | 9 A | 9 A |
| Conv. therm. current with 4 contacts | 8 A | 8 A |

Safety relays PNOZsigma PNOZ s10

| Times | 750110 | 751110 |
|--|--|--|
| Switch-on delay | | |
| With automatic start after power on typ. | 30 ms | 30 ms |
| With automatic start after power on max. | 50 ms | 50 ms |
| Delay-on de-energisation | | |
| With E-STOP typ. | 20 ms | 20 ms |
| With E-STOP max. | 30 ms | 30 ms |
| With power failure typ. | 20 ms | 20 ms |
| With power failure max. | 30 ms | 30 ms |
| Environmental data | 750110 | 751110 |
| Climatic suitability | EN 60068-2-78 | EN 60068-2-78 |
| Ambient temperature | | |
| Temperature range | -10 - 55 °C | -10 - 55 °C |
| Storage temperature | | |
| Temperature range | -40 - 85 °C | -40 - 85 °C |
| Climatic suitability | | |
| Humidity | 93 % r. h. at 40 °C | 93 % r. h. at 40 °C |
| Condensation during operation | Not permitted | Not permitted |
| EMC | EN 60947-5-1, EN 61000-6-2, EN 61000-6-4, EN 61326-3-1 | EN 60947-5-1, EN 61000-6-2, EN 61000-6-4, EN 61326-3-1 |
| Vibration | | |
| In accordance with the standard | EN 60068-2-6 | EN 60068-2-6 |
| Frequency | 10 - 55 Hz | 10 - 55 Hz |
| Amplitude | 0,35 mm | 0,35 mm |
| Airgap creepage | | |
| In accordance with the standard | EN 60947-1 | EN 60947-1 |
| Overvoltage category | III | III |
| Pollution degree | 2 | 2 |
| Rated insulation voltage | 250 V | 250 V |
| Rated impulse withstand voltage | 6 kV | 6 kV |
| Protection type | | |
| Mounting area (e.g. control cabinet) | IP54 | IP54 |
| Housing | IP40 | IP40 |
| Terminals | IP20 | IP20 |
| Mechanical data | 750110 | 751110 |
| Mounting position | Any | Any |
| Mechanical life | 10,000,000 cycles | 10,000,000 cycles |

Safety relays PNOZsigma PNOZ s10

| Mechanical data | 750110 | 751110 |
|---|--|---|
| Material | | |
| Bottom | PC | PC |
| Front | PC | PC |
| Top | PC | PC |
| Connection type | Screw terminal | Cage clamp terminal |
| Mounting type | plug-in | plug-in |
| Conductor cross section with screw terminals | | |
| 1 core flexible | 0,25 - 2,5 mm ² , 24 - 12 AWG | – |
| 2 core with the same cross section, flexible with crimp connectors, no plastic sleeve | 0,25 - 1 mm ² , 24 - 16 AWG | – |
| 2 core with the same cross section, flexible without crimp connectors or with TWIN crimp connectors | 0,2 - 1,5 mm ² , 24 - 16 AWG | – |
| Torque setting with screw terminals | 0,5 Nm | – |
| Conductor cross section with spring-loaded terminals: Flexible with/without crimp connector | – | 0,2 - 2,5 mm ² , 24 - 12 AWG |
| Spring-loaded terminals: Terminal points per connection | – | 2 |
| Stripping length with spring-loaded terminals | – | 9 mm |
| Dimensions | | |
| Height | 98 mm | 100 mm |
| Width | 45 mm | 45 mm |
| Depth | 120 mm | 120 mm |
| Weight | 295 g | 295 g |

Where standards are undated, the 2014-07 latest editions shall apply.

Safety relays PNOZsigma PNOZ s10

Safety characteristic data

| Operating Mode | EN ISO 13849-1: 2015 PL | EN ISO 13849-1: 2015 Category | EN 62061 SIL CL | EN 62061 PFH _D [1/h] | IEC 61511 SIL | IEC 61511 PFD | EN ISO 13849-1: 2015 T _M [year] |
|--------------------------------|----------------------------|----------------------------------|--------------------|------------------------------------|------------------|------------------|---|
| Safety contacts, instantaneous | PL e | Cat. 4 | SIL CL 3 | 2,31E-09 | SIL 3 | 2,03E-06 | 20 |

All the units used within a safety function must be considered when calculating the safety characteristic data.

Supplementary data

The PFH value depends on the switching frequency and the load on the relay output. If the service life graphs are not accessible, the stated PFH value can be used irrespective of the switching frequency and the load, as the PFH value already considers the relay's B10d value as well as the failure rates of the other components.

Safety relays PNOZsigma PNOZ s10

Service life graph

The service life graphs indicate the number of cycles from which failures due to wear must be expected. The wear is mainly caused by the electrical load; the mechanical load is negligible.

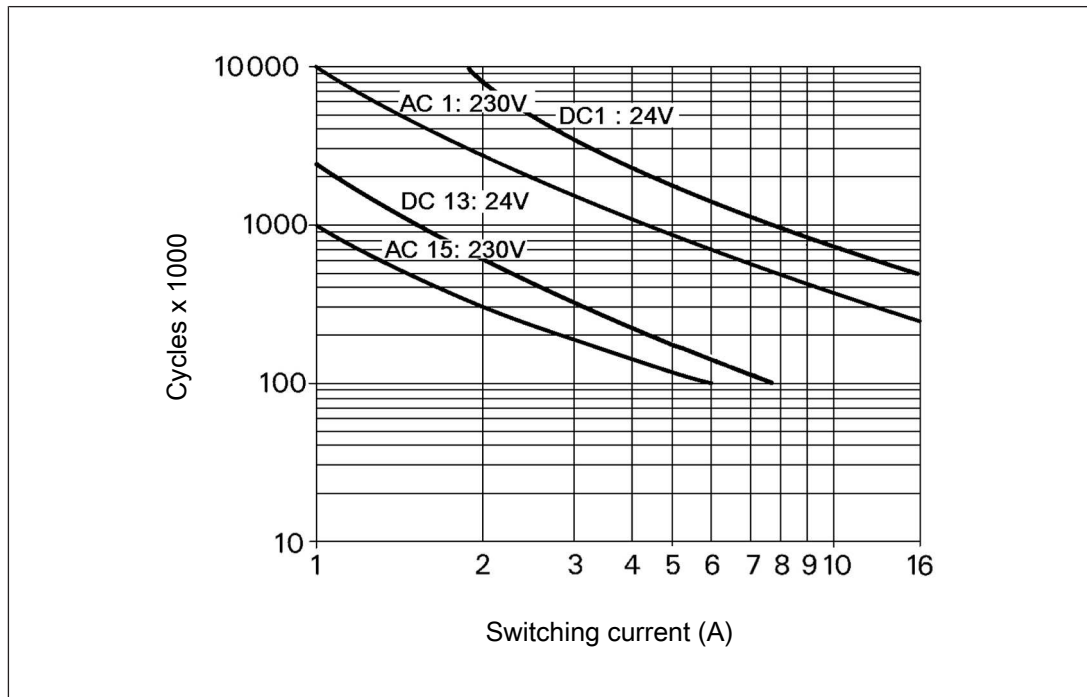

Fig.: Service life graphs at 24 V DC and 230 V AC

Safety relays PNOZsigma PNOZ s10

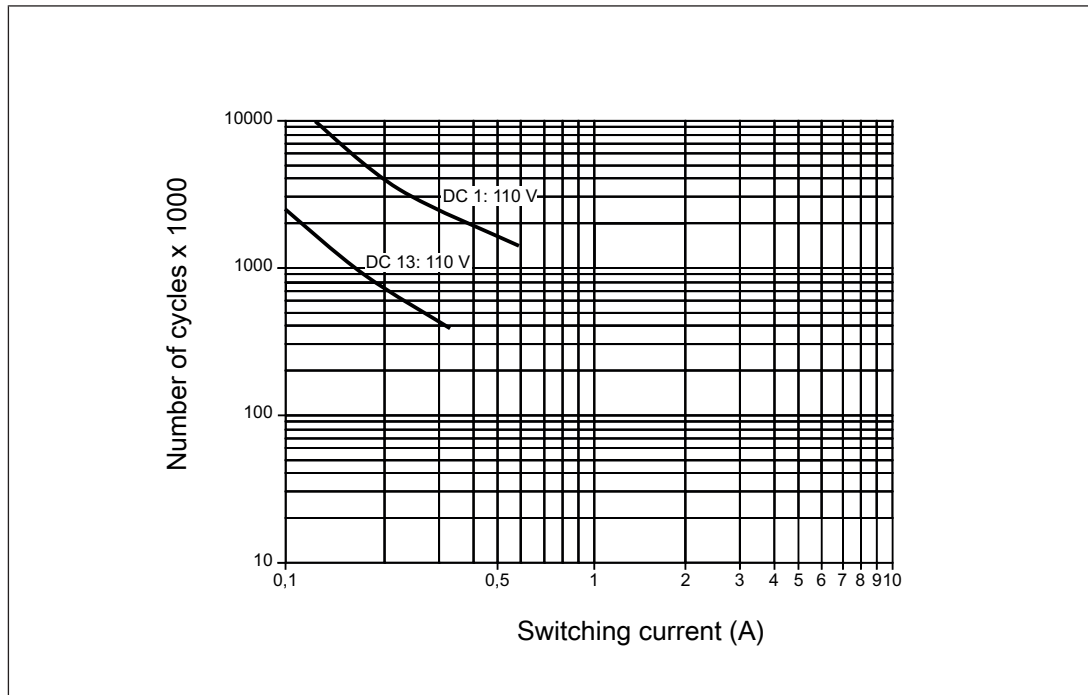

Fig.: Service life graphs at 110 V DC

Example

- ▶ Inductive load: 2 A
- ▶ Utilisation category: AC15
- ▶ Contact service life: 300 000 cycles

Provided the application to be implemented requires fewer than 300 000 cycles, the PFH value (see Technical details) can be used in the calculation.

To increase the service life, sufficient spark suppression must be provided on all output contacts. With capacitive loads, any power surges that occur must be noted. With DC contactors, use flywheel diodes for spark suppression.

Order reference

| Product type | Features | Connection type | Order No. |
|--------------|----------|-------------------------|-----------|
| PNOZ s10 | 24 VDC | Screw terminals | 750 110 |
| PNOZ s10 C | 24 VDC | Spring-loaded terminals | 751 110 |

Safety relays PNOZsigma PNOZ s11

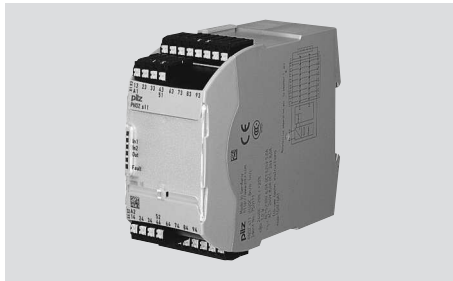

Unit features

- ▶ Positive-guided relay outputs:
 - 8 safety contacts (N/O), instantaneous
 - 1 auxiliary contact (N/C), instantaneous
- ▶ LED for:
 - Input status, channel 1
 - Input status, channel 2
 - Switch status of the safety contacts
 - Fault
- ▶ Plug-in connection terminals (either spring-loaded terminal or screw terminal)
- ▶ See order reference for unit types

Block diagram/terminal configuration

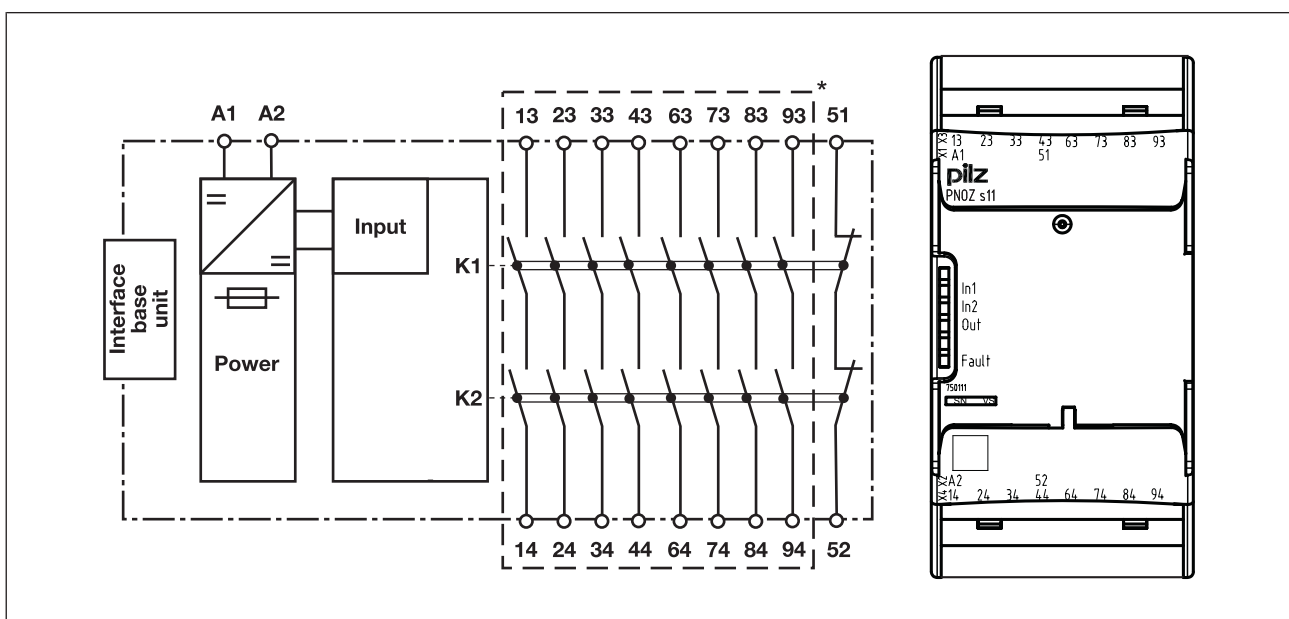

*Safe separation from non-marked area in accordance with EN 60947-1, 6 kV, basic insulation between all safety contacts.

Safety relays PNOZsigma PNOZ s11

Function description

with PNOZsigma base unit:

- ▶ Dual-channel operation via PNOZsigma connector

without PNOZsigma base unit:

- ▶ Single-channel operation: one input circuit affects the output relays

Timing diagram

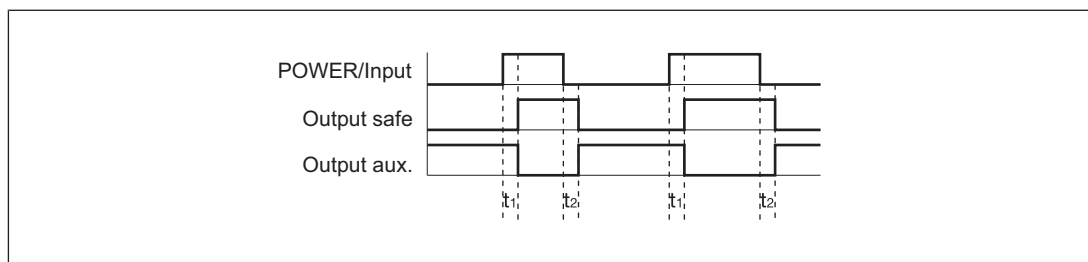

Legend

- ▶ POWER/Input: Supply voltage/input circuit
- ▶ Output safe: Safety contacts
- ▶ Output aux.: Auxiliary contacts
- ▶ t_1 : Switch-on delay
- ▶ t_2 : Delay-on de-energisation

Installation

Install contact expansion module without base unit:

- ▶ Ensure that the plug terminator is inserted at the side of the unit.

Connect base unit and PNOZsigma contact expansion module:

- ▶ Remove the plug terminator at the side of the base unit and at the contact expander module
- ▶ Connect the base unit and the contact expansion module using the connector supplied, before mounting the units to the DIN rail.

Control cabinet installation

- ▶ The safety relay should be installed in a control cabinet with a protection type of at least IP54.
- ▶ Use the notch on the rear of the unit to attach it to a DIN rail (35 mm).
- ▶ When installed vertically: Secure the unit by using a fixing element (e.g. retaining bracket or end angle).
- ▶ Push the unit upwards or downwards before lifting it from the DIN rail.

Safety relays PNOZsigma PNOZ s11

Wiring

Please note:

- ▶ Information given in the "[Technical details \[785\]](#)" must be followed.
- ▶ Outputs 13-14, 23-24, 33-34, 43-44, 63-64, 73-74, 83-84, 93-94 are safety contacts; output 51-52 is an auxiliary contact (e.g. for display).
- ▶ Auxiliary contact 51-52 should **not** be used for safety circuits!
- ▶ To prevent contact welding, a fuse should be connected before the output contacts (see [Technical details \[785\]](#)).
- ▶ Calculation of the max. cable length l_{max} in the input circuit:

$$l_{max} = \frac{R_{lmax}}{R_i / km}$$

R_{lmax} = max. overall cable resistance (see [Technical details \[785\]](#))

R_i / km = cable resistance/km

- ▶ Use copper wire that can withstand 60/75 °C.
- ▶ Sufficient fuse protection must be provided on all output contacts with capacitive and inductive loads.
- ▶ Ensure the wiring and EMC requirements of IEC 60204-1 are met.
- ▶ The power supply must comply with the regulations for extra low voltages with protective electrical separation (SELV, PELV) in accordance with VDE 0100, Part 410.

Preparing for operation

| Supply voltage | AC | DC |
|---|----------------|--------------|
| | | |
| Input circuit | Single-channel | Dual-channel |
| Base unit: Safety relay PNOZ X | | |
| Base unit: Safety relay PNOZelog Driven via semiconductor outputs (24 VDC) | | |

Safety relays PNOZsigma PNOZ s11

| Feedback loop | Base unit: Safety relay PNOZ X | Base unit: Safety relay PNOZelog |
|---|-----------------------------------|--|
| The inputs that evaluate the feedback loop will depend on the base unit and application | | |
| Connection to PNOZsigma base unit/PNOZmulti Mini base unit | Base unit: Safety relay PNOZsigma | Base unit: Small control system PNOZmulti Mini |
| The feedback loop is connected and evaluated via the connector | | |

Dimensions in mm

*with spring-loaded terminals

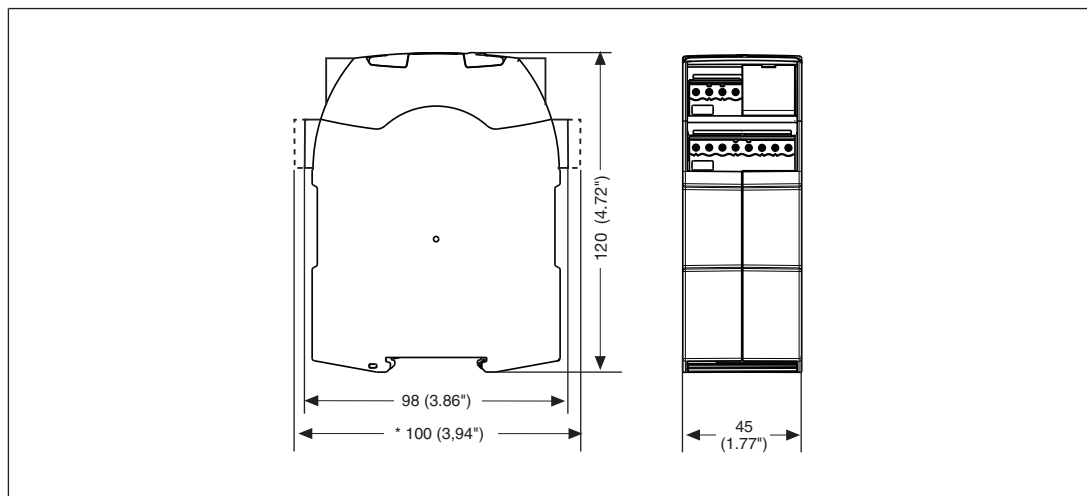

Safety relays PNOZsigma PNOZ s11

Technical details

| General | 750111 | 751111 |
|--------------------------------------|--|--|
| Approvals | CCC, CE, EAC (Eurasian), TÜV, cULus Listed | CCC, CE, EAC (Eurasian), TÜV, cULus Listed |
| Electrical data | 750111 | 751111 |
| Supply voltage | | |
| Voltage | 24 V | 24 V |
| Kind | DC | DC |
| Voltage tolerance | -20 %/+20 % | -20 %/+20 % |
| Output of external power supply (DC) | 3 W | 3 W |
| Residual ripple DC | 20 % | 20 % |
| Duty cycle | 100 % | 100 % |
| Inputs | 750111 | 751111 |
| Number | 1 | 1 |
| Voltage at | | |
| Input circuit DC | 24 V | 24 V |
| Current at | | |
| Input circuit DC | 95 mA | 95 mA |
| Max. inrush current impulse | | |
| Current pulse, input circuit | 2 A | 2 A |
| Pulse duration, input circuit | 0,1 ms | 0,1 ms |
| Max. overall cable resistance RI-max | | |
| Single-channel at UB DC | 30 Ohm | 30 Ohm |
| Relay outputs | 750111 | 751111 |
| Number of output contacts | | |
| Safety contacts (N/O), instantaneous | 8 | 8 |
| Auxiliary contacts (N/C) | 1 | 1 |
| Max. short circuit current IK | 1 kA | 1 kA |
| Utilisation category | | |
| In accordance with the standard | EN 60947-4-1 | EN 60947-4-1 |

Safety relays PNOZsigma PNOZ s11

| Relay outputs | 750111 | 751111 |
|--|-------------------------------|-------------------------------|
| Utilisation category of safety contacts | | |
| AC1 at | 240 V | 240 V |
| Min. current | 0,01 A | 0,01 A |
| Max. current | 6 A | 6 A |
| Max. power | 1500 VA | 1500 VA |
| DC1 at | 24 V | 24 V |
| Min. current | 0,01 A | 0,01 A |
| Max. current | 6 A | 6 A |
| Max. power | 150 W | 150 W |
| Utilisation category of auxiliary contacts | | |
| AC1 at | 240 V | 240 V |
| Min. current | 0,01 A | 0,01 A |
| Max. current | 6 A | 6 A |
| Max. power | 1500 VA | 1500 VA |
| DC1 at | 24 V | 24 V |
| Min. current | 0,01 A | 0,01 A |
| Max. current | 6 A | 6 A |
| Max. power | 150 W | 150 W |
| Utilisation category | | |
| In accordance with the standard | EN 60947-5-1 | EN 60947-5-1 |
| Utilisation category of safety contacts | | |
| AC15 at | 230 V | 230 V |
| Max. current | 5 A | 5 A |
| DC13 (6 cycles/min) at | 24 V | 24 V |
| Max. current | 5 A | 5 A |
| Utilisation category of auxiliary contacts | | |
| AC15 at | 230 V | 230 V |
| Max. current | 5 A | 5 A |
| DC13 (6 cycles/min) at | 24 V | 24 V |
| Max. current | 5 A | 5 A |
| Utilisation category in accordance with UL | | |
| Voltage | 240 V AC G.U. (same polarity) | 240 V AC G.U. (same polarity) |
| With current | 6 A | 6 A |
| Voltage | 24 V DC G. U. | 24 V DC G. U. |
| With current | 6 A | 6 A |

Safety relays PNOZsigma PNOZ s11

| Relay outputs | 750111 | 751111 |
|--|---------------------------|---------------------------|
| External contact fuse protection, safety contacts | | |
| In accordance with the standard | EN 60947-5-1 | EN 60947-5-1 |
| Max. melting integral | 260 A²s | 260 A²s |
| Blow-out fuse, quick | 10 A | 10 A |
| Blow-out fuse, slow | 6 A | 6 A |
| Blow-out fuse, gG | 10 A | 10 A |
| Circuit breaker 24V AC/DC, characteristic B/C | 6 A | 6 A |
| External contact fuse protection, auxiliary contacts | | |
| Max. melting integral | 160 A²s | 160 A²s |
| Blow-out fuse, quick | 10 A | 10 A |
| Blow-out fuse, slow | 6 A | 6 A |
| Blow-out fuse, gG | 6 A | 6 A |
| Circuit breaker 24 V AC/DC, characteristic B/C | 6 A | 6 A |
| Contact material | AgCuNi + 0,2 µm Au | AgCuNi + 0,2 µm Au |
| Conventional thermal current while loading several contacts | 750111 | 751111 |
| I _{th} per contact at UB DC; AC1: 240 V, DC1: 24 V | | |
| Conv. therm. current with 1 contact | 6 A | 6 A |
| Conv. therm. current with 2 contacts | 6 A | 6 A |
| Conv. therm. current with 3 contacts | 6 A | 6 A |
| Conv. therm. current with 4 contacts | 6 A | 6 A |
| Conv. therm. current with 5 contacts | 6 A | 6 A |
| Conv. therm. current with 6 contacts | 5,7 A | 5,7 A |
| Conv. therm. current with 7 contacts | 5,3 A | 5,3 A |
| Conv. therm. current with 8 contacts | 5 A | 5 A |
| Times | 750111 | 751111 |
| Switch-on delay | | |
| With automatic start after power on typ. | 30 ms | 30 ms |
| With automatic start after power on max. | 50 ms | 50 ms |

Safety relays PNOZsigma PNOZ s11

| Times | 750111 | 751111 |
|--------------------------------------|---|---|
| Delay-on de-energisation | | |
| With E-STOP typ. | 18 ms | 18 ms |
| With E-STOP max. | 30 ms | 30 ms |
| With power failure typ. | 18 ms | 18 ms |
| With power failure max. | 30 ms | 30 ms |
| Environmental data | | |
| Climatic suitability | EN 60068-2-78 | EN 60068-2-78 |
| Ambient temperature | | |
| Temperature range | -10 - 55 °C | -10 - 55 °C |
| Storage temperature | | |
| Temperature range | -40 - 85 °C | -40 - 85 °C |
| Climatic suitability | | |
| Humidity | 93 % r. h. at 40 °C | 93 % r. h. at 40 °C |
| Condensation during operation | Not permitted | Not permitted |
| EMC | EN 60947-5-1, EN 61000-6-2, EN 61000-6-4, EN 61326-3-1 | EN 60947-5-1, EN 61000-6-2, EN 61000-6-4, EN 61326-3-1 |
| Vibration | | |
| In accordance with the standard | EN 60068-2-6 | EN 60068-2-6 |
| Frequency | 10 - 55 Hz | 10 - 55 Hz |
| Amplitude | 0,35 mm | 0,35 mm |
| Airgap creepage | | |
| In accordance with the standard | EN 60947-1 | EN 60947-1 |
| Overvoltage category | III | III |
| Pollution degree | 2 | 2 |
| Rated insulation voltage | 250 V | 250 V |
| Rated impulse withstand voltage | 6 kV | 6 kV |
| Protection type | | |
| Mounting area (e.g. control cabinet) | IP54 | IP54 |
| Housing | IP40 | IP40 |
| Terminals | IP20 | IP20 |
| Mechanical data | | |
| Mounting position | Any | Any |
| Mechanical life | 10,000,000 cycles | 10,000,000 cycles |
| Material | | |
| Bottom | PC | PC |
| Front | PC | PC |
| Top | PC | PC |
| Connection type | Screw terminal | Cage clamp terminal |
| Mounting type | plug-in | plug-in |

Safety relays PNOZsigma PNOZ s11

| Mechanical data | 750111 | 751111 |
|---|---|--|
| Conductor cross section with screw terminals | | |
| 1 core flexible | 0,25 - 2,5 mm², 24 - 12 AWG | – |
| 2 core with the same cross section, flexible with crimp connectors, no plastic sleeve | 0,25 - 1 mm², 24 - 16 AWG | – |
| 2 core with the same cross section, flexible without crimp connectors or with TWIN crimp connectors | 0,2 - 1,5 mm², 24 - 16 AWG | – |
| Torque setting with screw terminals | 0,5 Nm | – |
| Conductor cross section with spring-loaded terminals: Flexible with/without crimp connector | – | 0,2 - 2,5 mm², 24 - 12 AWG |
| Spring-loaded terminals: Terminal points per connection | – | 2 |
| Stripping length with spring-loaded terminals | – | 9 mm |
| Dimensions | | |
| Height | 98 mm | 100 mm |
| Width | 45 mm | 45 mm |
| Depth | 120 mm | 120 mm |
| Weight | 335 g | 335 g |

Where standards are undated, the 2014-07 latest editions shall apply.

Safety characteristic data

| Operating Mode | EN ISO 13849-1: 2015 PL | EN ISO 13849-1: 2015 Category | EN 62061 SIL CL | EN 62061 PFH _D [1/h] | IEC 61511 SIL | IEC 61511 PFD | EN ISO 13849-1: 2015 T _M [year] |
|--------------------------------|----------------------------|----------------------------------|--------------------|------------------------------------|------------------|------------------|---|
| Safety contacts, instantaneous | PL e | Cat. 4 | SIL CL 3 | 2,31E-09 | SIL 3 | 2,03E-06 | 20 |

All the units used within a safety function must be considered when calculating the safety characteristic data.

Safety relays PNOZsigma PNOZ s11

Supplementary data

The PFH value depends on the switching frequency and the load on the relay output. If the service life graphs are not accessible, the stated PFH value can be used irrespective of the switching frequency and the load, as the PFH value already considers the relay's B10d value as well as the failure rates of the other components.

Service life graph

The service life graphs indicate the number of cycles from which failures due to wear must be expected. The wear is mainly caused by the electrical load; the mechanical load is negligible.

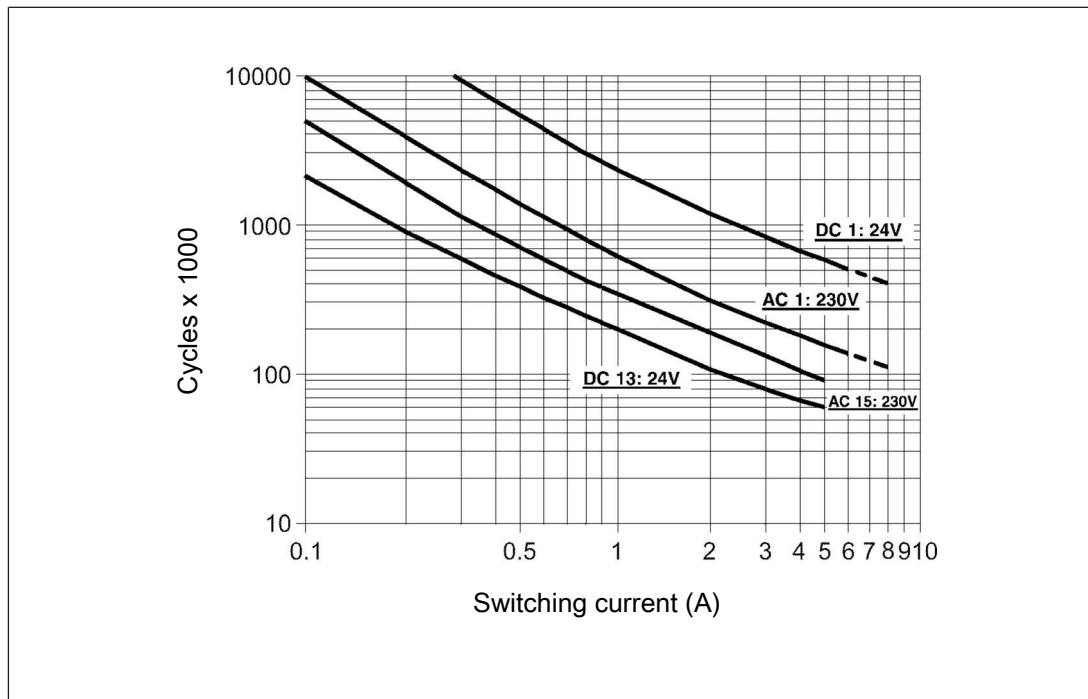

Fig.: Service life graphs at 24 V DC and 230 V AC

Safety relays PNOZsigma PNOZ s11

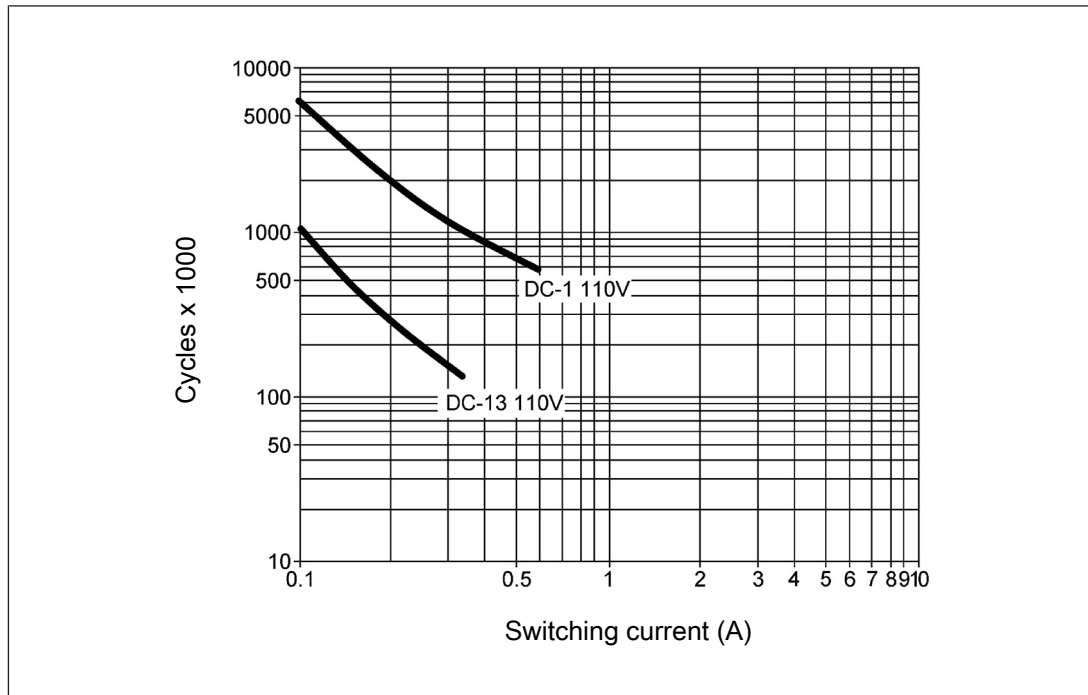

Fig.: Service life graphs at 110 V DC

Example

- ▶ Inductive load: 0.2 A
- ▶ Utilisation category: AC15
- ▶ Contact service life: 2 000 000 cycles

Provided the application to be implemented requires fewer than 2 000 000 cycles, the PFH value (see [Technical details \[785\]](#)) can be used in the calculation.

To increase the service life, sufficient spark suppression must be provided on all output contacts. With capacitive loads, any power surges that occur must be noted. With DC contactors, use flywheel diodes for spark suppression.

Order reference

| Product type | Features | Terminals | Order No. |
|--------------|----------|-------------------------|-----------|
| PNOZ s11 | 24 VDC | Screw terminals | 750 111 |
| PNOZ s11 C | 24 VDC | Spring-loaded terminals | 751 111 |

Safety relays PNOZsigma PNOZ s20

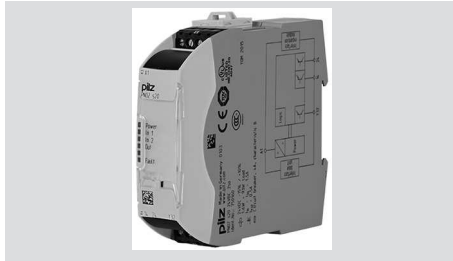

Unit features

- ▶ Semiconductor outputs:
 - 2 safety outputs instantaneous
 - 1 auxiliary output instantaneous
- ▶ Connection option for expansion modules
- ▶ LED display for:
 - Supply voltage
 - Switch state of safety outputs
 - Input state channel 1/2
 - Fault
- ▶ Plug-in connection terminals (either spring-loaded terminal or screw terminal)
- ▶ See order reference for unit types

Block diagram/terminal configuration

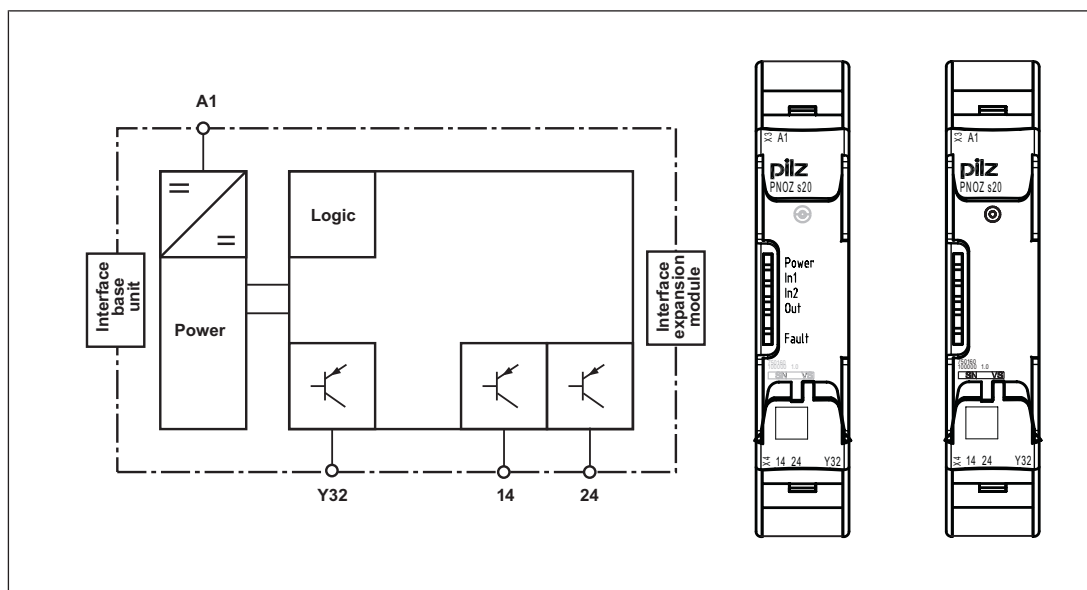

Fig.: Centre: Front view with cover, right: Front view without cover

Safety relays PNOZsigma PNOZ s20

Function description

The contact expansion module PNOZ s20 also provides safety outputs. It is driven by a base unit PNOZsigma.

Several PNOZ s20 units can be connected to the base unit (see [Installation \[📖 793\]](#)).

Functional procedure after supply voltage has been applied and the base unit's safety contacts are closed:

- ▶ There is a high signal at safety outputs 14 and 24 and auxiliary output Y32.
- ▶ LEDs "IN1", "IN2" and "Out" are lit.

Functional procedure if one or both of the base unit's safety contacts open:

- ▶ There is a low signal at safety outputs 14 and 24 and auxiliary output Y32.
- ▶ LEDs "IN1", "IN2" and "Out" go out.

The safety outputs will not switch back to a high signal until all the base unit's safety contacts are open and then closed again.

Safety outputs are checked via regular off tests.

- ▶ Max. duration of off time during self test, see Technical details
- ▶ Safety outputs are switched off for the duration of the off time during the self test.

The auxiliary output Y32 displays the state of the safety outputs.

Installation

Control cabinet installation

- ▶ The safety relay should be installed in a control cabinet with a protection type of at least IP54.
- ▶ Use the notch on the rear of the unit to attach it to a DIN rail.
- ▶ Ensure the unit is mounted securely on a vertical DIN rail (35 mm) by using a fixing element (e.g. retaining bracket or an end angle).

Push the unit upwards or downwards before lifting it from the DIN rail.

Connect the base unit and contact expansion module PNOZ s20

- ▶ Remove the plug terminator at the side of the base unit and at the left of the contact expansion module.
- ▶ Connect the base unit and the contact expansion module using the connector supplied, before mounting the units to the DIN rail.

Connect the contact expansion module PNOZ s20 to the contact expansion modules PNOZsigma

- ▶ Connect the contact expansion modules using the connectors supplied.
- ▶ Fit the terminator to the module on the right.
- ▶ Expansion options are described in the following table.

Safety relays PNOZsigma PNOZ s20

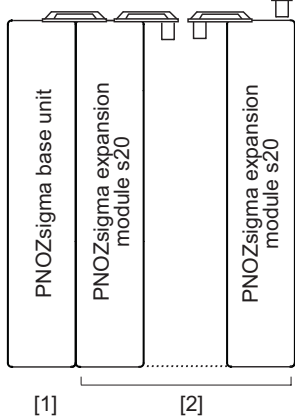
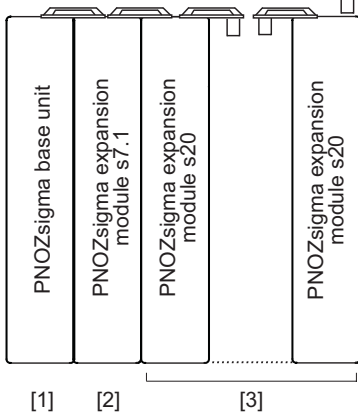
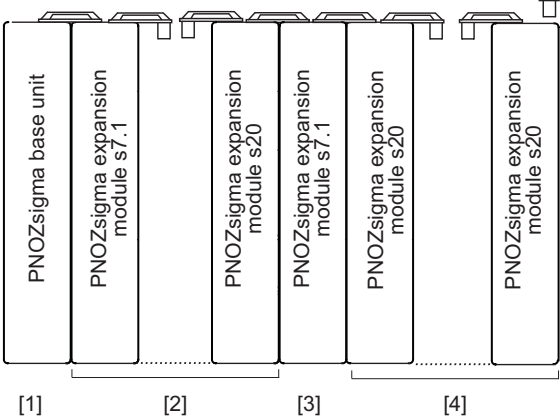
| Expansion options | Consider the max. power consumption of all the units used in the application |
|---|---|
| <p>[1]: Base unit PNOZ s3/s4/s4.1/s5/s6/s6.1</p> <p>[2]: Up to 5 contact expansion modules PNOZ s20 (final block with terminator)</p> |  <p>The diagram shows a vertical stack of modules. The top module is labeled 'PNOZsigma base unit' and is marked with [1]. Below it are up to five 'PNOZsigma expansion module s20' units, with the entire group marked with [2]. A dashed line indicates the connection between the base unit and the expansion modules.</p> |
| <p>[1]: Base unit PNOZsigma</p> <p>[2]: Contact expansion module PNOZ s7.1</p> <p>[3]*: Up to 10 contact expansion modules PNOZ s20 (final block with terminator)</p> |  <p>The diagram shows a vertical stack of modules. The top module is labeled 'PNOZsigma base unit' and is marked with [1]. Below it is one 'PNOZsigma expansion module s7.1' marked with [2]. Below that are up to ten 'PNOZsigma expansion module s20' units, with the entire group marked with [3]. A dashed line indicates the connection between the base unit and the expansion modules.</p> |
| <p>[1]: Base unit PNOZsigma</p> <p>[2]: One contact expansion module PNOZ s7.1 and up to 9 contact expansion modules PNOZ s20</p> <p>[3]: Contact expansion module PNOZ s7.1</p> <p>[4]*: Up to 10 contact expansion modules PNOZ s20 (final block with terminator)</p> |  <p>The diagram shows a vertical stack of modules. The top module is labeled 'PNOZsigma base unit' and is marked with [1]. Below it is one 'PNOZsigma expansion module s7.1' marked with [2]. Below that are up to nine 'PNOZsigma expansion module s20' units, with the entire group marked with [3]. A dashed line indicates the connection between the base unit and the expansion modules. The bottom-most module is marked with [4].</p> |

Safety relays PNOZsigma PNOZ s20

| Expansion options | Consider the max. power consumption of all the units used in the application |
|--|--|
| <p>[1]: Base unit PNOZsigma</p> <p>[2]: One contact expansion module PNOZ s7.1 and up to 9 contact expansion modules PNOZ s20</p> <p>[3]: Contact expansion module PNOZ s7.1</p> <p>[4]:* Up to 10 contact expansion modules PNOZ s7.2 (final block with terminator)</p> | |
| <p>[1]: Base unit PNOZsigma</p> <p>[2]: One contact expansion module PNOZ s7.1 and up to 9 contact expansion modules PNOZ s7.2</p> <p>[3]: Contact expansion module PNOZ s7.1</p> <p>[4]*: Up to 10 contact expansion modules PNOZ s20 (final block with terminator)</p> | |

*) Alternatively, one of the following units can be used as the final expansion block:

- ▶ PNOZ s7
- ▶ PNOZ s8
- ▶ PNOZ s9
- ▶ PNOZ s10
- ▶ PNOZ s11

These units sometimes require more power than the units combined in the table. If the maximum power consumption of all expansion modules is exceeded (see the technical details of the respective devices), you will need to reduce the number of connected PNOZ s20 or PNOZ s7.2 units.

Example:

Use of PNOZ s10 with a power consumption of 3 W

The max. number of expansion modules PNOZ s20 or PNOZ s7.2 is reduced by 2:

- ▶ 1 unit, in order to comply with the max. power consumption and
- ▶ 1 unit, which is replaced by PNOZ s10

Safety relays PNOZsigma PNOZ s20

Wiring

Please note:

- ▶ Information given in the "[Technical details \[797\]](#)" must be followed.
- ▶ Outputs 14-24 are safety outputs; semiconductor output Y32 is an auxiliary output (e.g. for display).
- ▶ Use copper wire that can withstand 60/75 °C.
- ▶ Sufficient fuse protection must be provided on all output contacts with capacitive and inductive loads.
- ▶ Ensure the wiring and EMC requirements of IEC 60204-1 are met.
- ▶ The power supply must comply with the regulations for extra low voltages with protective electrical separation (SELV, PELV) in accordance with VDE 0100, Part 410.

Preparing for operation

| Supply voltage/input circuit/ feedback loop | AC | DC |
|--|----|----|
| Contact expansion module PNOZ s20 | / | |

Connect the N/C contacts from external contactors to the feedback loop on the base unit.

| Safety output | Single-channel operation | Dual-channel operation |
|---------------|--------------------------|------------------------|
| | | |

With dual-channel operation, always use both safety outputs for a safety function.

Safety relays PNOZsigma PNOZ s20

Dimensions in mm

* with spring-loaded terminals

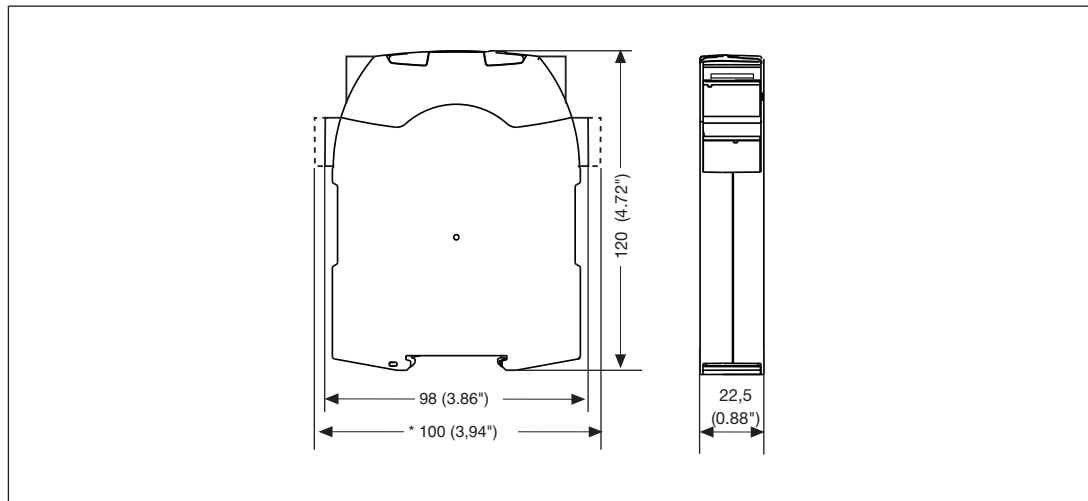

Technical details

| General | 750160 | 751160 |
|---|---|---|
| Approvals | CCC, CE, EAC (Eurasian), TÜV, cULus Listed | CCC, CE, EAC (Eurasian), TÜV, cULus Listed |
| Electrical data | 750160 | 751160 |
| Supply voltage | | |
| for | Module supply | Module supply |
| Voltage | 24 V | 24 V |
| Kind | DC | DC |
| Voltage tolerance | -15 %/+10 % | -15 %/+10 % |
| Output of external power supply (DC) | 95 W | 95 W |
| Output of external power supply (DC) at no load | 1,6 W | 1,6 W |
| Residual ripple DC | 20 % | 20 % |
| Duty cycle | 100 % | 100 % |
| External unit fuse protection F1 max. | 4 A, circuit breaker 24 VAC/DC, characteristic B | 4 A, circuit breaker 24 VAC/DC, characteristic B |
| Semiconductor outputs | 750160 | 751160 |
| Overall performance ext. loading, semiconductor | 93 W | 93 W |
| Number of safety outputs | | |
| Instantaneous | 2 | 2 |
| Number of auxiliary outputs | 1 | 1 |
| Residual current at "0" signal | 2 mA | 2 mA |

Safety relays PNOZsigma PNOZ s20

| Semiconductor outputs | 750160 | 751160 |
|---|--|--|
| Max. internal voltage drop | 120 mV | 120 mV |
| Max. duration of off time during self test | 600 µs | 600 µs |
| Switching capability, 2 safety outputs under load | | |
| Current | 1,5 A | 1,5 A |
| Power | 40 W | 40 W |
| Switching capability, 1 safety output under load | | |
| Current | 2 A | 2 A |
| Power | 50 W | 50 W |
| Switching capability auxiliary outputs | | |
| Current | 0,5 A | 0,5 A |
| Power | 13 W | 13 W |
| Max. line capacitance at the outputs without load | 2 nF | 2 nF |
| Times | 750160 | 751160 |
| Switch-on delay | | |
| Max. switch-on delay after power on | 4 s | 4 s |
| With automatic start typ. | 60 ms | 60 ms |
| With automatic start max. | 210 ms | 210 ms |
| Recovery time at max. switching frequency 1/s | | |
| After E-STOP | 50 ms | 50 ms |
| After power failure | 50 ms | 50 ms |
| Response time t_r semiconductor outputs | | |
| typ. | 25 ms | 25 ms |
| max. | 35 ms | 35 ms |
| Environmental data | 750160 | 751160 |
| Climatic suitability | EN 60068-2-78 | EN 60068-2-78 |
| Ambient temperature | | |
| Temperature range | -10 - 55 °C | -10 - 55 °C |
| Storage temperature | | |
| Temperature range | -40 - 85 °C | -40 - 85 °C |
| Climatic suitability | | |
| Humidity | 93 % r. h. at 40 °C | 93 % r. h. at 40 °C |
| Condensation during operation | Not permitted | Not permitted |
| EMC | EN 60947-5-1, EN 61000-6-2, EN 61000-6-4, EN 61326-3-1 | EN 60947-5-1, EN 61000-6-2, EN 61000-6-4, EN 61326-3-1 |

Safety relays PNOZsigma PNOZ s20

| Environmental data | 750160 | 751160 |
|---|---|--|
| Vibration | | |
| In accordance with the standard | EN 60068-2-6 | EN 60068-2-6 |
| Frequency | 10 - 55 Hz | 10 - 55 Hz |
| Amplitude | 0,35 mm | 0,35 mm |
| Airgap creepage | | |
| In accordance with the standard | EN 60947-1 | EN 60947-1 |
| Overvoltage category | III | III |
| Pollution degree | 2 | 2 |
| Rated insulation voltage | 30 V | 30 V |
| Rated impulse withstand voltage | 0,8 kV | 0,8 kV |
| Protection type | | |
| Mounting area (e.g. control cabinet) | IP54 | IP54 |
| Housing | IP40 | IP40 |
| Terminals | IP20 | IP20 |
| Mechanical data | 750160 | 751160 |
| Mounting position | Any | Any |
| Material | | |
| Bottom | PC | PC |
| Front | PC | PC |
| Top | PC | PC |
| Connection type | Screw terminal | Spring-loaded terminal |
| Mounting type | plug-in | plug-in |
| Conductor cross section with screw terminals | | |
| 1 core flexible | 0,25 - 2,5 mm², 24 - 12 AWG | – |
| 2 core with the same cross section, flexible with crimp connectors, no plastic sleeve | 0,25 - 1 mm², 24 - 16 AWG | – |
| 2 core with the same cross section, flexible without crimp connectors or with TWIN crimp connectors | 0,2 - 1,5 mm², 24 - 16 AWG | – |
| Torque setting with screw terminals | 0,5 Nm | – |
| Conductor cross section with spring-loaded terminals: Flexible with/without crimp connector | – | 0,2 - 2,5 mm², 24 - 12 AWG |
| Spring-loaded terminals: Terminal points per connection | – | 2 |
| Stripping length with spring-loaded terminals | – | 9 mm |

Safety relays PNOZsigma PNOZ s20

| Mechanical data | 750160 | 751160 |
|-----------------|---------|---------|
| Dimensions | | |
| Height | 98 mm | 100 mm |
| Width | 22,5 mm | 22,5 mm |
| Depth | 120 mm | 120 mm |
| Weight | 120 g | 120 g |

Where standards are undated, the 2014-06 latest editions shall apply.

Safety characteristic data

| Operating Mode | EN ISO 13849-1: 2015 PL | EN ISO 13849-1: 2015 Category | EN 62061 SIL CL | EN 62061 PFH _D [1/h] | IEC 61511 SIL | IEC 61511 PFD | EN ISO 13849-1: 2015 T _M [year] |
|----------------|----------------------------|----------------------------------|--------------------|------------------------------------|------------------|------------------|---|
| 1-channel | PL d | Cat. 2 | SIL CL 2 | 1,32E-08 | SIL 2 | 1,17E-03 | 20 |
| 2-channel | PL e | Cat. 4 | SIL CL 3 | 2,03E-09 | SIL 3 | 1,85E-04 | 20 |

All the units used within a safety function must be considered when calculating the safety characteristic data.

Order reference

| Product type | Features | Connection type | Order no. |
|--------------|----------|-------------------------|-----------|
| PNOZ s20 | 24 VDC | Screw terminals | 750 160 |
| PNOZ s20 C | 24 VDC | Spring-loaded terminals | 751 160 |

Safety relays PNOZsigma PNOZ s22



Unit features

- ▶ Positive-guided relay outputs:
 - 6 safety contacts (N/O), instantaneous
 - 2 auxiliary contacts (N/C), instantaneous
- ▶ 3 safety contacts and 1 auxiliary contact each; these can be controlled separately
- ▶ LED indicator for:
 - Input state of channel Ext.1/O0
 - Input state of channel Ext.2/O1
- ▶ Plug-in connection terminals (either spring-loaded terminal or screw terminal)
- ▶ See order reference for unit types

Block diagram/terminal configuration

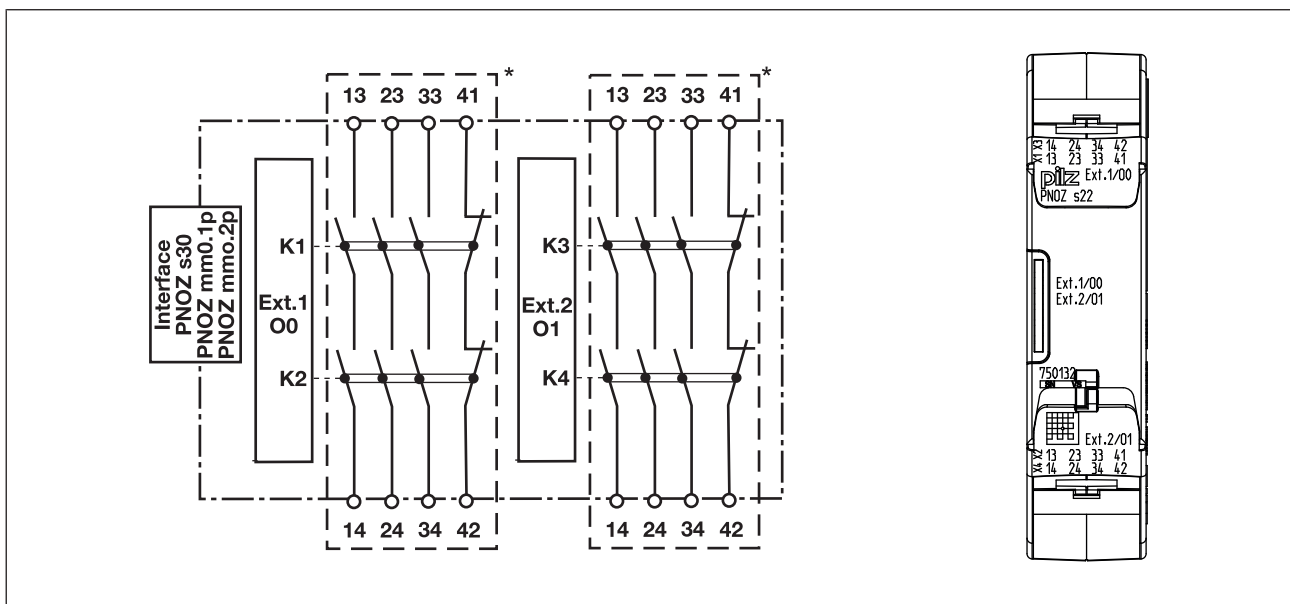

*Safe separation from non-marked area in accordance with EN 60947-1, 6 kV, basic insulation between all safety contacts.

Safety relays PNOZsigma PNOZ s22

Function description

- ▶ Dual-channel operation and supply voltage via PNOZsigma connector
- ▶ 3 safety contacts and 1 auxiliary contact each; these can be controlled separately

Installation

Connect the contact expansion block to the PNOZ s30 or base unit PNOZ mm0.1p/
PNOZ mm0.2p

- ▶ Connect the contact expansion block using the connector supplied.

Control cabinet installation

- ▶ The safety relay should be installed in a control cabinet with a protection type of at least IP54.
- ▶ Use the notch on the rear of the unit to attach it to a DIN rail.
- ▶ Ensure the unit is mounted securely on a vertical DIN rail (35 mm) by using a fixing element (e.g. retaining bracket or an end angle).

Push the unit upwards or downwards before lifting it from the DIN rail.

Wiring

Please note:

- ▶ Information given in the "[Technical details \[804\]](#)" must be followed.
- ▶ The wiring guidelines in the base units' operating instructions must be taken into account.
- ▶ Outputs 13-14, 23-24, 33-34 are safety contacts; output 41-42 is an auxiliary contact (e.g. for display).
- ▶ Auxiliary contact 41-42 should **not** be used for safety circuits!
- ▶ To prevent contact welding, a fuse should be connected before the output contacts (see [Technical details \[804\]](#)).
- ▶ Use copper wire that can withstand 60/75 °C.
- ▶ Sufficient fuse protection must be provided on all output contacts with capacitive and inductive loads.
- ▶ Ensure the wiring and EMC requirements of IEC 60204-1 are met.
- ▶ The power supply must comply with the regulations for extra low voltages with protective electrical separation (SELV, PELV) in accordance with VDE 0100, Part 410.

Safety relays PNOZsigma PNOZ s22

Preparing for operation

Connection

| | AC | DC |
|--|--|---|
| Supply voltage/input circuit/feed-back loop | | |
| Connection to speed monitor PNOZ s30/PNOZmulti Mini base unit | Base unit: Speed monitor PNOZ s30 | Base unit: Small control system PNOZmulti Mini |
| The feedback loop is connected and evaluated via the connector | | |

Dimensions in mm

*with spring-loaded terminals

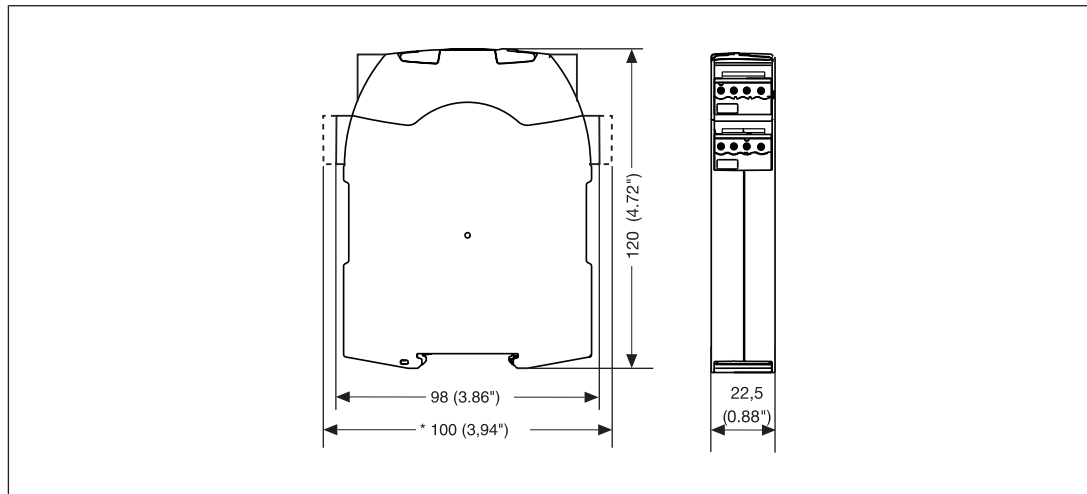

Safety relays PNOZsigma PNOZ s22

Technical details

| General | 750132 | 751132 |
|--|--|--|
| Approvals | CCC, EAC (Eurasian), TÜV, cULus Listed | CCC, EAC (Eurasian), TÜV, cULus Listed |
| Electrical data | 750132 | 751132 |
| Supply voltage | | |
| Voltage tolerance | -15 %/+20 % | -15 %/+20 % |
| Supply voltage | | |
| Voltage | 24 V | 24 V |
| Kind | DC | DC |
| Power consumption | 1,5 W | 1,5 W |
| Duty cycle | 100 % | 100 % |
| Relay outputs | 750132 | 751132 |
| Number of output contacts | | |
| Safety contacts (N/O), instantaneous | 6 | 6 |
| Auxiliary contacts (N/C) | 2 | 2 |
| Max. short circuit current IK | 1 kA | 1 kA |
| Utilisation category | | |
| In accordance with the standard | EN 60947-4-1 | EN 60947-4-1 |
| Utilisation category of safety contacts | | |
| AC1 at | 240 V | 240 V |
| Min. current | 0,01 A | 0,01 A |
| Max. current | 6 A | 6 A |
| Max. power | 1500 VA | 1500 VA |
| DC1 at | 24 V | 24 V |
| Min. current | 0,01 A | 0,01 A |
| Max. current | 6 A | 6 A |
| Max. power | 150 W | 150 W |
| Utilisation category of auxiliary contacts | | |
| AC1 at | 240 V | 240 V |
| Min. current | 0,01 A | 0,01 A |
| Max. current | 6 A | 6 A |
| Max. power | 1500 VA | 1500 VA |
| DC1 at | 24 V | 24 V |
| Min. current | 0,01 A | 0,01 A |
| Max. current | 6 A | 6 A |
| Max. power | 150 W | 150 W |

Safety relays PNOZsigma PNOZ s22

| Relay outputs | 750132 | 751132 |
|--|--------------------------------------|--------------------------------------|
| Utilisation category | | |
| In accordance with the standard | EN 60947-5-1 | EN 60947-5-1 |
| Utilisation category of safety contacts | | |
| AC15 at | 230 V | 230 V |
| Max. current | 3 A | 3 A |
| DC13 (6 cycles/min) at | 24 V | 24 V |
| Max. current | 4 A | 4 A |
| Utilisation category of auxiliary contacts | | |
| AC15 at | 230 V | 230 V |
| Max. current | 4 A | 4 A |
| DC13 (6 cycles/min) at | 24 V | 24 V |
| Max. current | 4 A | 4 A |
| Utilisation category in accordance with UL | | |
| Voltage | 240 V AC G.U. (same polarity) | 240 V AC G.U. (same polarity) |
| With current | 6 A | 6 A |
| Voltage | 24 V DC G. U. | 24 V DC G. U. |
| With current | 6 A | 6 A |
| External contact fuse protection, safety contacts | | |
| In accordance with the standard | EN 60947-5-1 | EN 60947-5-1 |
| Max. melting integral | 66 A²s | 66 A²s |
| Blow-out fuse, quick | 6 A | 6 A |
| Blow-out fuse, slow | 4 A | 4 A |
| Blow-out fuse, gG | 6 A | 6 A |
| Circuit breaker 24V AC/DC, characteristic B/C | 4 A | 4 A |
| External contact fuse protection, auxiliary contacts | | |
| Max. melting integral | 66 A²s | 66 A²s |
| Blow-out fuse, quick | 6 A | 6 A |
| Blow-out fuse, slow | 4 A | 4 A |
| Blow-out fuse, gG | 6 A | 6 A |
| Circuit breaker 24 V AC/DC, characteristic B/C | 4 A | 4 A |
| Contact material | AgCuNi + 0,2 µm Au | AgCuNi + 0,2 µm Au |

Safety relays PNOZsigma PNOZ s22

| Conventional thermal current while loading several contacts | 750132 | 751132 |
|--|---|---|
| Ith per contact at UB DC; AC1: 240 V, DC1: 24 V | | |
| Conv. therm. current with 1 contact | 6 A | 6 A |
| Conv. therm. current with 2 contacts | 5 A | 5 A |
| Conv. therm. current with 3 contacts | 4 A | 4 A |
| Times | 750132 | 751132 |
| Switch-on delay | | |
| With automatic start typ. | 11 ms | 11 ms |
| With automatic start max. | 20 ms | 20 ms |
| Delay-on de-energisation | | |
| With E-STOP typ. | 12 ms | 12 ms |
| With E-STOP max. | 20 ms | 20 ms |
| Environmental data | 750132 | 751132 |
| Climatic suitability | EN 60068-2-78 | EN 60068-2-78 |
| Ambient temperature | | |
| Temperature range | -10 - 55 °C | -10 - 55 °C |
| Storage temperature | | |
| Temperature range | -40 - 85 °C | -40 - 85 °C |
| Climatic suitability | | |
| Humidity | 93 % r. h. at 40 °C | 93 % r. h. at 40 °C |
| Condensation during operation | Not permitted | Not permitted |
| EMC | EN 60947-5-1, EN 61000-6-2, EN 61000-6-4, EN 61326-3-1 | EN 60947-5-1, EN 61000-6-2, EN 61000-6-4, EN 61326-3-1 |
| Vibration | | |
| In accordance with the standard | EN 60068-2-6 | EN 60068-2-6 |
| Frequency | 10 - 55 Hz | 10 - 55 Hz |
| Amplitude | 0,35 mm | 0,35 mm |
| Airgap creepage | | |
| In accordance with the standard | EN 60947-1 | EN 60947-1 |
| Overvoltage category | III | III |
| Pollution degree | 2 | 2 |
| Rated insulation voltage | 250 V | 250 V |
| Rated impulse withstand voltage | 6 kV | 6 kV |
| Protection type | | |
| Mounting area (e.g. control cabinet) | IP54 | IP54 |
| Housing | IP40 | IP40 |
| Terminals | IP20 | IP20 |

Safety relays PNOZsigma PNOZ s22

| Mechanical data | 750132 | 751132 |
|---|--|---|
| Mounting position | Any | Any |
| Mechanical life | 10,000,000 cycles | 10,000,000 cycles |
| Material | | |
| Bottom | PC | PC |
| Front | PC | PC |
| Top | PC | PC |
| Connection type | Screw terminal | Spring-loaded terminal |
| Mounting type | plug-in | plug-in |
| Conductor cross section with screw terminals | | |
| 1 core flexible | 0,25 - 2,5 mm ² , 24 - 12 AWG | – |
| 2 core with the same cross section, flexible with crimp connectors, no plastic sleeve | 0,25 - 1 mm ² , 24 - 16 AWG | – |
| 2 core with the same cross section, flexible without crimp connectors or with TWIN crimp connectors | 0,2 - 1,5 mm ² , 24 - 16 AWG | – |
| Torque setting with screw terminals | 0,5 Nm | – |
| Conductor cross section with spring-loaded terminals: Flexible with/without crimp connector | – | 0,2 - 2,5 mm ² , 24 - 12 AWG |
| Spring-loaded terminals: Terminal points per connection | – | 2 |
| Stripping length with spring-loaded terminals | – | 9 mm |
| Dimensions | | |
| Height | 98 mm | 100 mm |
| Width | 22,5 mm | 22,5 mm |
| Depth | 120 mm | 120 mm |
| Weight | 265 g | 265 g |

Where standards are undated, the 2014-07 latest editions shall apply.

The values for conventional thermal current stated in the technical details apply when the contacts from Ext.1/O0 **and** Ext.2/O1 are under load simultaneously.

Conventional thermal current when either the contacts from Ext.1/O0 **or** the contacts from Ext.2/O1 are under load:

| Number of contacts in total | I _{th} [A] per contact |
|-----------------------------|---------------------------------|
| 1 | 6 A |
| 2 | 6 A |
| 3 | 5 A |

Safety relays PNOZsigma PNOZ s22

Safety characteristic data

| Operating Mode | EN ISO 13849-1: 2015 PL | EN ISO 13849-1: 2015 Category | EN 62061 SIL CL | EN 62061 PFH _D [1/h] | IEC 61511 SIL | IEC 61511 PFD | EN ISO 13849-1: 2015 T _M [year] |
|--------------------------------|----------------------------|----------------------------------|--------------------|------------------------------------|------------------|------------------|---|
| Safety contacts, instantaneous | PL e | Cat. 4 | SIL CL 3 | 2,31E-09 | SIL 3 | 2,03E-06 | 20 |

Supplementary data

The PFH value depends on the switching frequency and the load on the relay output. If the service life graphs are not accessible, the stated PFH value can be used irrespective of the switching frequency and the load, as the PFH value already considers the relay's B10d value as well as the failure rates of the other components.

Service life graph

The service life graphs indicate the number of cycles from which failures due to wear must be expected. The wear is mainly caused by the electrical load; the mechanical load is negligible.

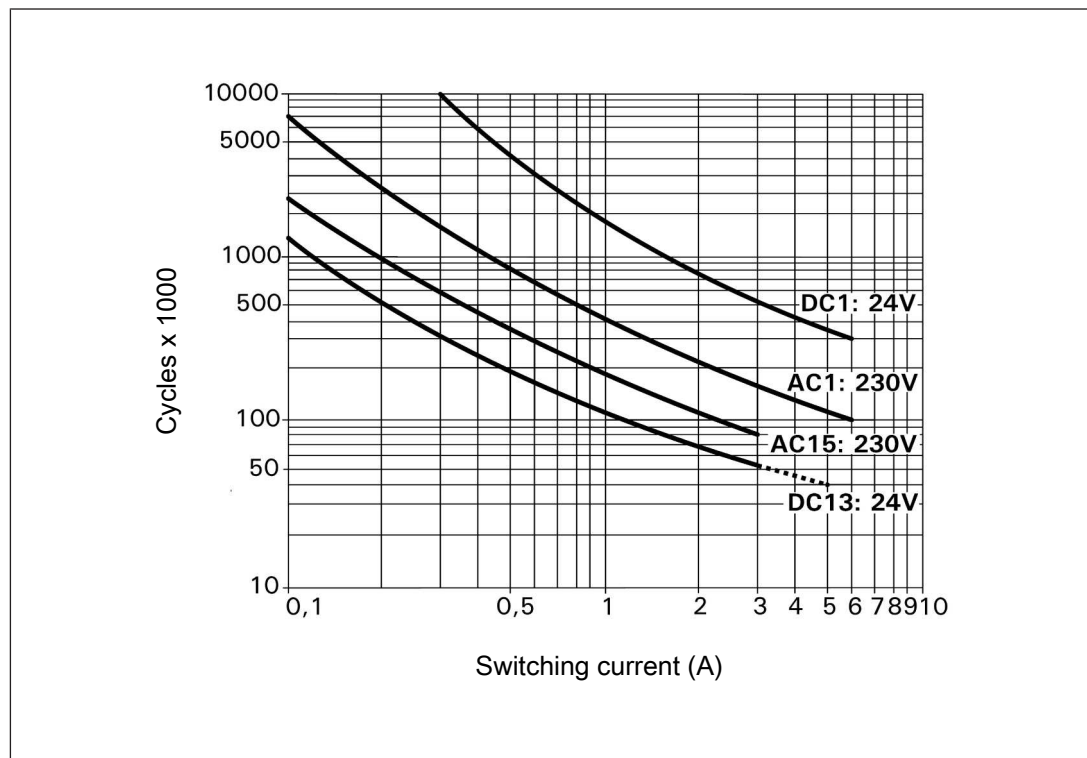

Fig.: Service life graphs at 24 VDC and 230 VAC

Safety relays PNOZsigma PNOZ s22

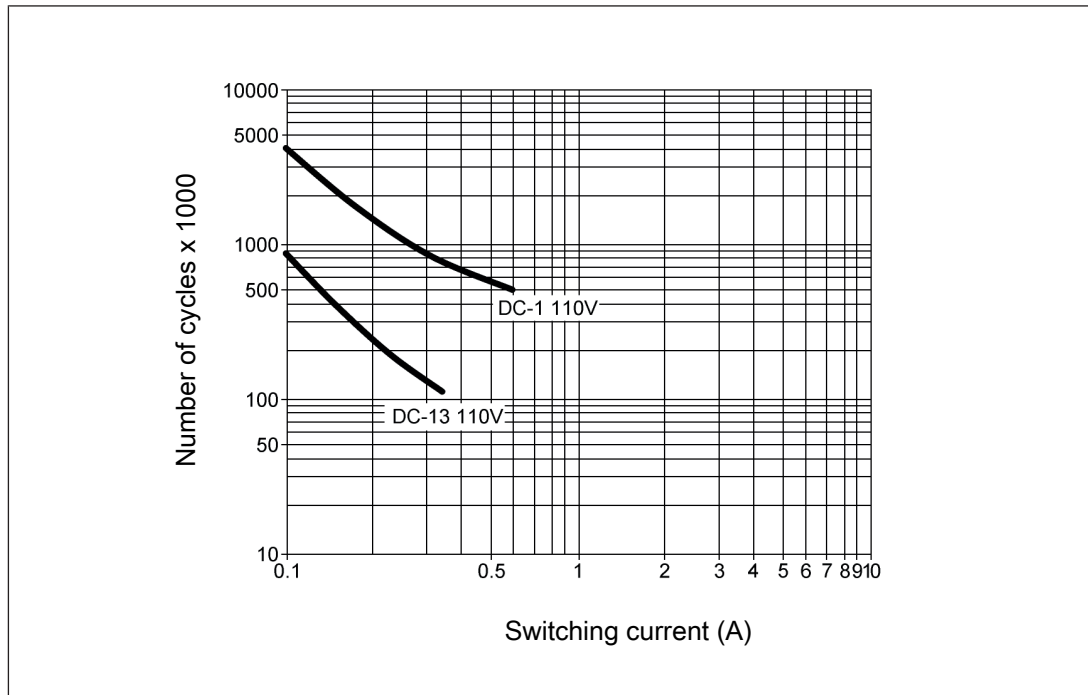

Fig.: Service life graphs at 110 VDC

Example

- ▶ Inductive load: 0.2 A
- ▶ Utilisation category: AC15
- ▶ Contact service life: 1 000 000 cycles

Provided the application to be implemented requires fewer than 1 000 000 cycles, the PFH value (see [Technical details \[804\]](#)) can be used in the calculation.

To increase the service life, sufficient spark suppression must be provided on all relay contacts. With capacitive loads, any power surges that occur must be noted. With DC contactors, use flywheel diodes for spark suppression.

Order reference

| Product type | Features | Connection type | Order No. |
|--------------|----------|-------------------------|-----------|
| PNOZ s22 | 24 VDC | Screw terminals | 750 132 |
| PNOZ s22 C | 24 VDC | Spring-loaded terminals | 751 132 |

Safety relays PNOZsigma PNOZ s30

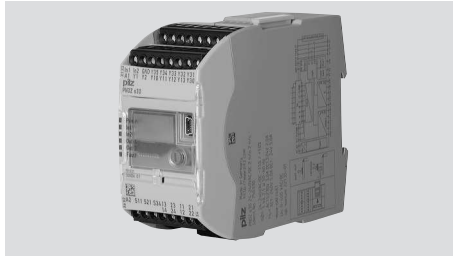

Overview

Unit structure

Range

Scope of supply:

- ▶ Speed monitor PNOZ s30
- ▶ Terminator
- ▶ Connection terminals
- ▶ Chip card
- ▶ Chip card holder
- ▶ Documentation on data medium

Unit features

Using the product PNOZ s30:

Speed monitor for safe monitoring of standstill, speed, speed range, position and direction.

The product has the following features:

- ▶ Measured value recorded by
 - Incremental encoder
 - Proximity switch
- ▶ Measured variables
 - Standstill
 - Speed
 - Speed range
 - Position
 - Direction
 - Analogue voltage (track S)

Safety relays PNOZsigma PNOZ s30

- ▶ Positive-guided relay outputs
 - 2 safety contacts (NO)
 - 2 auxiliary contacts (NC)
- ▶ Semiconductor outputs
 - 4 auxiliary outputs
- ▶ Expansion interface for 2 more safe relay outputs that be controlled separately
- ▶ Can be configured via the display on the speed monitor
- ▶ Configuration is stored on a chip card
- ▶ Display
 - Current frequencies
 - Current position
 - Warning and error messages
- ▶ Status and fault LEDs
- ▶ Rotary encoder connection technology:
RJ45 socket

Safety relays PNOZsigma PNOZ s30

Front/side view

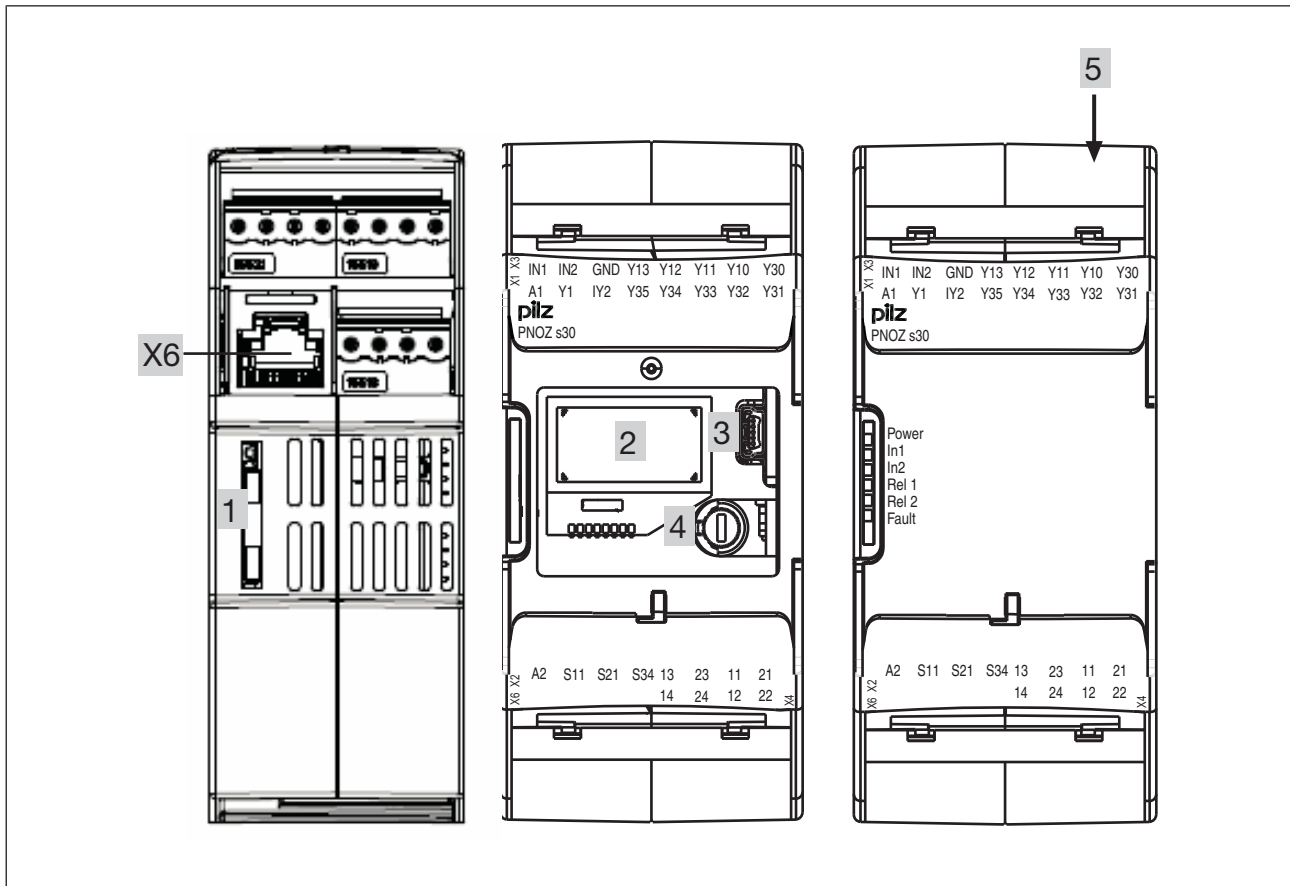

Fig.: Left: Side view, centre: Front view without cover, right: Front view with cover

Legend:

- ▶ A1, A2:
Supply connections
- ▶ In1, In2, GND:
Proximity switch 1 - In1 (track A) and 2 - In2 (track B) and GND
- ▶ Y10 ... Y13:
Select inputs (SEL1, SEL2, SEL4, SEL8)
- ▶ 13-14 and 23-24:
Relay outputs (safety contacts)
- ▶ 11-12 and 21-22:
Relay outputs (auxiliary contacts)
- ▶ Y32 ... Y35: Semiconductor outputs (auxiliary outputs)
- ▶ S11: +24 V / 30 mA (supply for S34, Y1 and Y2)
- ▶ S21: 0 V (GND for S11, S34, Y1 and Y2)
- ▶ S34: Start input

Safety relays PNOZsigma PNOZ s30

- ▶ Y30: 0 V ext (GND for select input and semiconductor outputs)
- ▶ Y31: 24 V ext (supply for semiconductor outputs)
- ▶ Y1, Y2:
 - Y1: Feedback input for Rel. 1
 - Y2: Feedback input for Rel. 2
- ▶ X6: RJ45 socket for connecting the encoder (tracks A, /A, B, /B, Z, /Z, S and GND). Proximity switches can be connected via RJ45 socket or connection terminals.
- ▶ 1: Chip card
- ▶ 2: Display format
- ▶ 3: USB connection (service only)
- ▶ 4: Rotary knob
- ▶ 5: Expansion interface for 2 more external relay outputs
- ▶ LEDs:
 - Power
 - In1
 - In2
 - Rel 1
 - Rel 2
 - Fault

Function description

Introduction

Proximity switches or rotary encoders record measured values, which are evaluated in the speed monitor PNOZ s30. There are 9 monitoring functions (F1 ... F9), which are performed simultaneously.

Up to 16 different parameter sets (P0 ... P15) for the monitoring functions can be selected via the select inputs.

Configuration of the monitoring functions is menu-driven, using a rotary knob. The outputs switch depending on the configuration.

An interface is available to connect a contact expansion module PNOZsigma, enabling the number of outputs to be expanded.

The relay conforms to the following safety criteria:

- ▶ The circuit is redundant with built-in self-monitoring.
- ▶ The safety function remains effective in the case of a component failure.

Safety relays PNOZsigma PNOZ s30

Block diagram

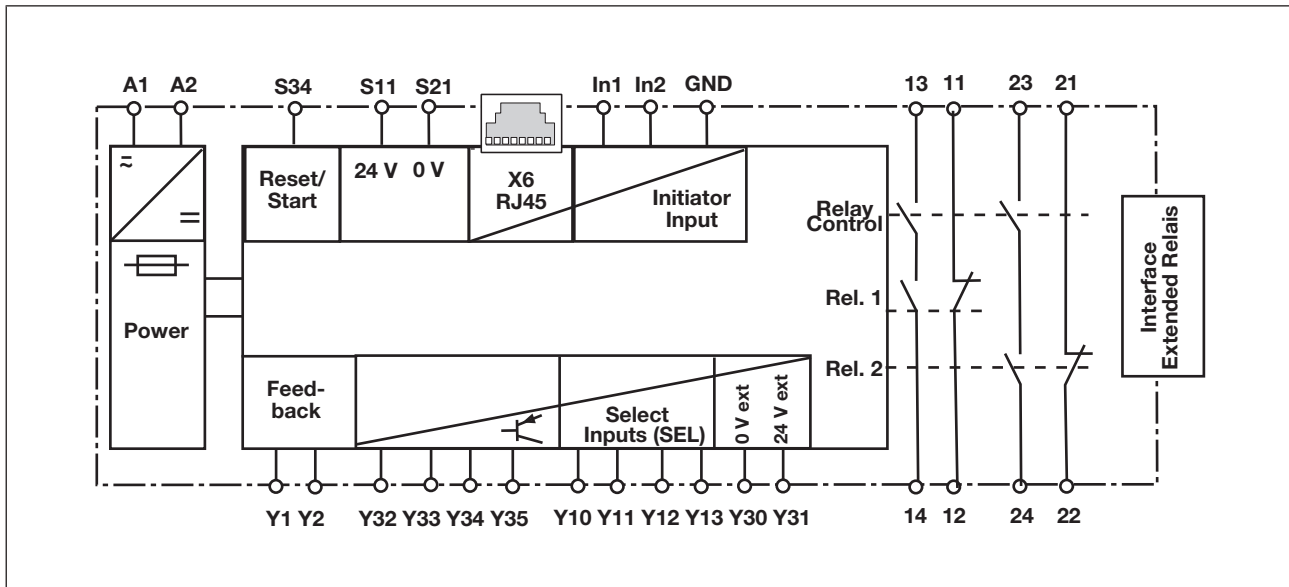

Functions

The following monitoring functions can be configured:

Standstill

With standstill monitoring, the output is switched on when the value falls below the stated standstill value; if the standstill value is exceeded, the output switches off.

Speed

With speed monitoring, the output switches off when the configured value is exceeded.

Safety relays PNOZsigma PNOZ s30

Timing diagram for standstill/speed monitoring:

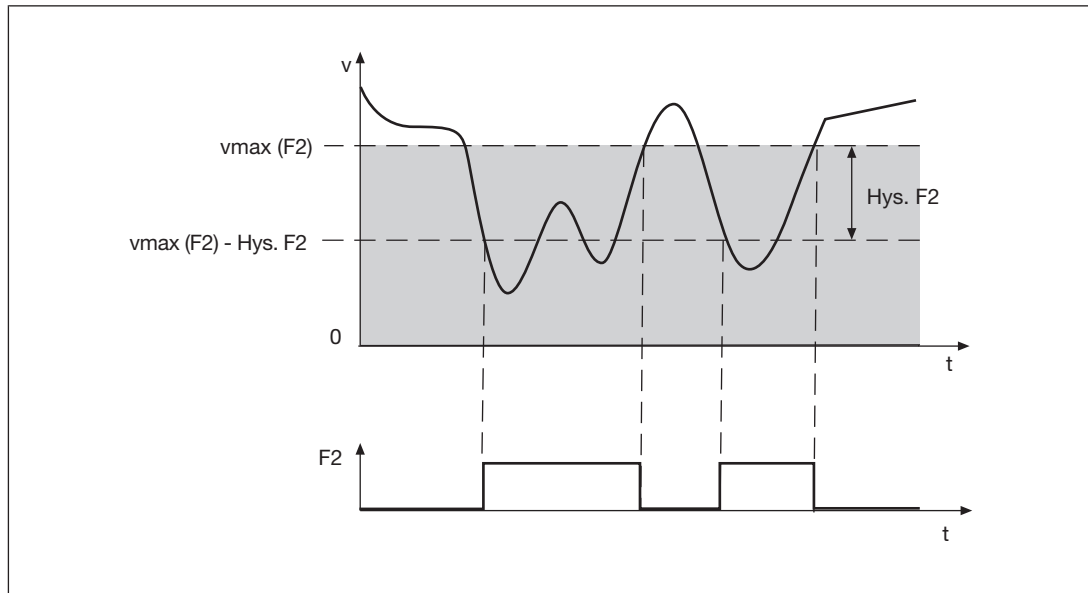

Speed range

With range monitoring, the output switches off if the rotational speed (velocity, frequency) is outside the configured range.

Timing diagram for speed range monitoring:

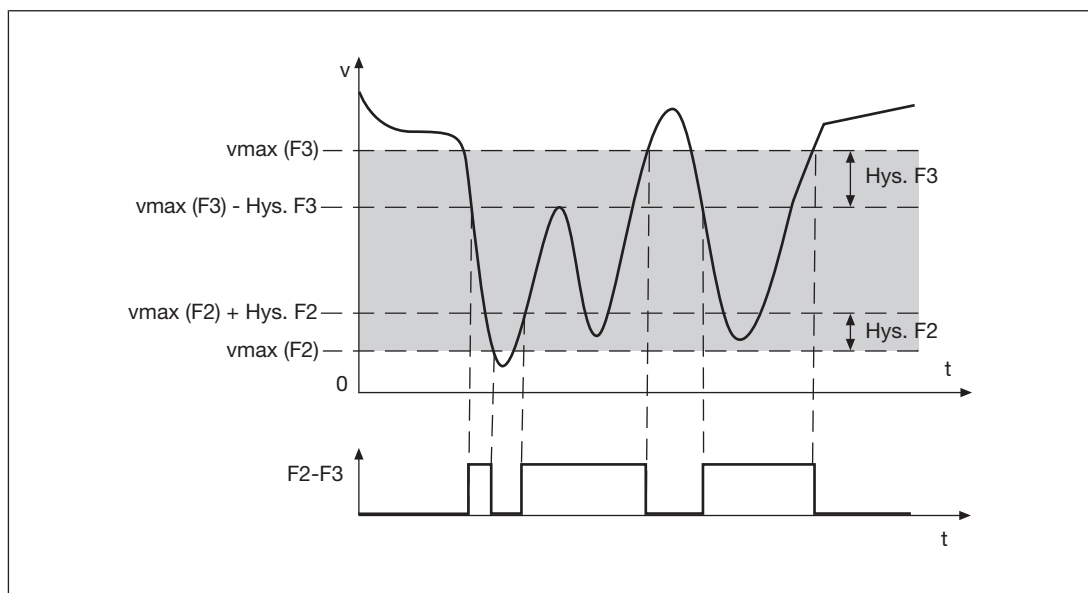

Safety relays PNOZsigma PNOZ s30

Position

Position monitoring is activated via a rising edge at the start input. The current position is adopted as a reference position in the middle of the position window (configured window width) and the assigned output is switched on.

The output will stay switched on provided the current position is within the position window.

Timing diagram for position monitoring:

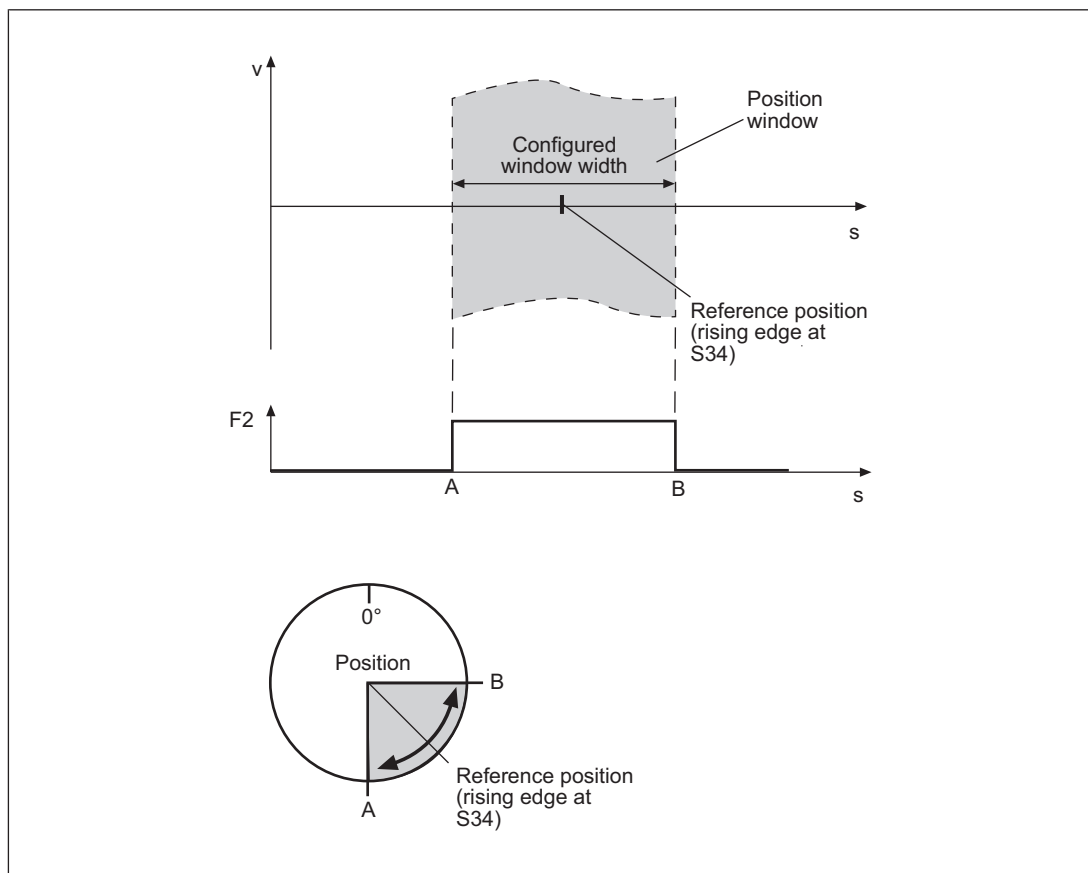

If the position moves outside the configured range, position monitoring is reset and the assigned outputs are switched off. Position monitoring can be restarted via a rising edge at the start input

A max. of 4 positions can be configured to be monitored simultaneously.

Please note:

- ▶ Active position monitoring is not started again by another rising edge at the start input.
- ▶ Active position monitoring continues unchanged even if a different parameter set is selected, which also uses position monitoring. This also applies if position monitoring is used in a different switch function.
- ▶ Active position monitoring is reset if another parameter set is selected, which does not use position monitoring.
- ▶ Position monitoring cannot be used if proximity switches are employed.

Safety relays PNOZsigma PNOZ s30

Direction

If the direction is to be detected safely, this function must be linked to a safety contact.

- ▶ If "Direct. Right" is configured, the safety output is switched on during normal operation in clockwise rotation.
- ▶ If "Direct. Left" is configured, the safety output is switched on during normal operation in anti-clockwise rotation.

For both directions, a tolerance can be entered for the wrong direction. In other words, the drive can run in the wrong direction up to the set tolerance value, without the assigned output switching off.

If an output has been switched off, it cannot switch back on again until the drive has been run in the right direction up to the tolerance value.

Please note:

- ▶ Direction monitoring is always active, irrespective of whether it is used in the selected parameter set.
- ▶ Direct.Right and Direct.Left are active when the PNOZ s30 is started up.
- ▶ Direction cannot be detected if proximity switches are used.

Timing diagram for direction monitoring:

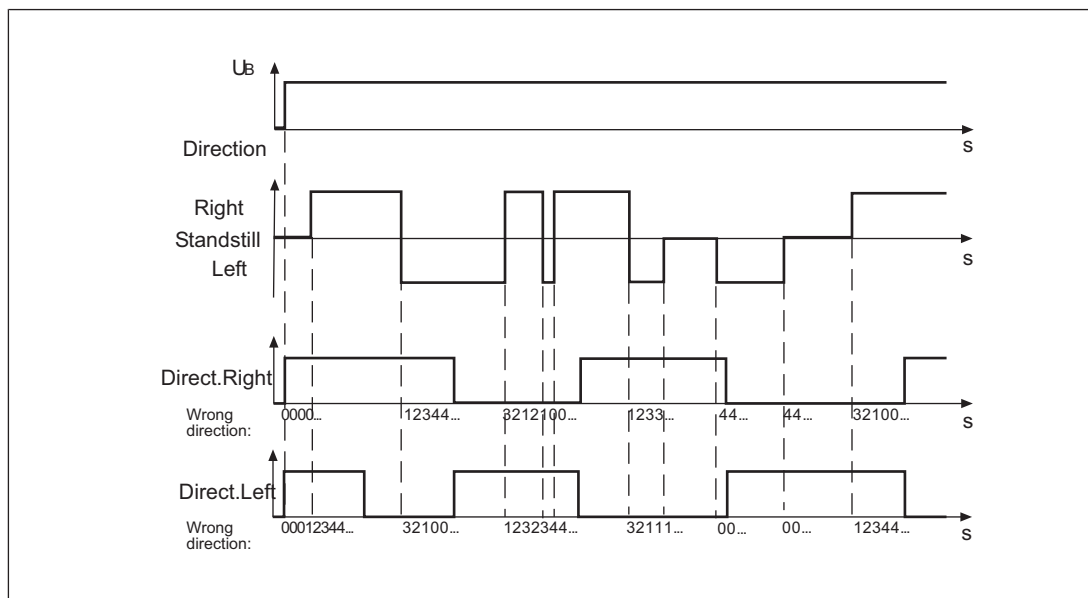

Configuration in the example:

- ▶ Wrong direction in anti-clockwise rotation
Max. right: 3 pulses
- ▶ Wrong direction in clockwise rotation
Max. left: 3 pulses

Safety relays PNOZsigma PNOZ s30

Monitoring for broken shearpins

An additional proximity switch or an HTL signal from an additional rotary encoder can be connected to track Z to monitor for broken shearpins. These must both be configured as Z-frequency monitoring.

Please note:

Monitoring for broken shearpins does not become active until

- ▶ The minimum speed has been exceeded and
- ▶ The tolerance for detecting feasibility errors has elapsed.

The minimum speed and tolerance depend on the ratio of the frequency at tracks AB " f_{AB} " to the frequency at track Z " f_Z " in your configuration (**f_{AB}/f_Z Verh.** setting in the menu).

Minimum speed:

- ▶ when **f_{AB}/f_Z Verh.** ≥ 1.0
 $f_Z = 70$ mHz or $f_{AB} = (f_{AB}/f_Z) \times 70$ mHz
- ▶ when **f_{AB}/f_Z Verh.** < 1.0
 $f_{AB} = 70$ mHz or $f_Z = 70$ mHz / (f_{AB}/f_Z)

Tolerance for detecting feasibility errors:

- ▶ when **f_{AB}/f_Z Verh.** ≥ 1.0
7.5 Z-pulses or $7.5 \times (f_{AB}/f_Z)$ AB-pulses
- ▶ when **f_{AB}/f_Z Verh.** < 1.0
4.5 AB-pulses or $4.5 / (f_{AB}/f_Z)$ Z-pulses

Hysteresis

For each switch function F1 ... F9 (with the exception of direction and position), a hysteresis can be configured. This prevents the outputs on the speed monitor from bouncing if there are fluctuations around the response value. The hysteresis becomes effective when the output is switched on:

Switch-on value = switching threshold – hysteresis

For the lower range limit:

Switch-on value = switching threshold + hysteresis

Start types

You can choose between the following start modes:

▶ Automatic start

If an automatic start is configured, the output switches on automatically if the speed does not reach the limit value, for example.

▶ Monitored start with rising edge

If a monitored start with rising edge is configured, the output switches on if the speed does not reach the limit value and then a rising edge was detected at S34.

Safety relays PNOZsigma PNOZ s30

▶ **Monitored start with falling edge**

If a monitored start with falling edge is configured, the output switches on if the speed does not reach the limit value and then a falling edge was detected at S34.

Switch delay

A delay time can be set for each output (see technical details). The outputs will not switch until the set time has elapsed. It is possible to configure whether the delay time is to be activated when switching on, switching off, or switching on and off.

Feedback loops

Feedback loops are used to monitor external contactors or relays. The corresponding feedback loop must be closed before starting.

Start-up delay

A start-up delay time can be configured, which prevents the evaluation of the encoder signals for the configured time period after the supply voltage is switched on.

Switching direction on semiconductor outputs

The semiconductor outputs can be operated in normally de-energised or normally energised mode.

Units

The values to be configured can be entered in various units. Depending on the axis type (linear or rotational axis), various units can be selected for speed and distance (see chapter entitled "Menu overview").

Safety relays PNOZsigma PNOZ s30

Timing diagram for speed monitoring

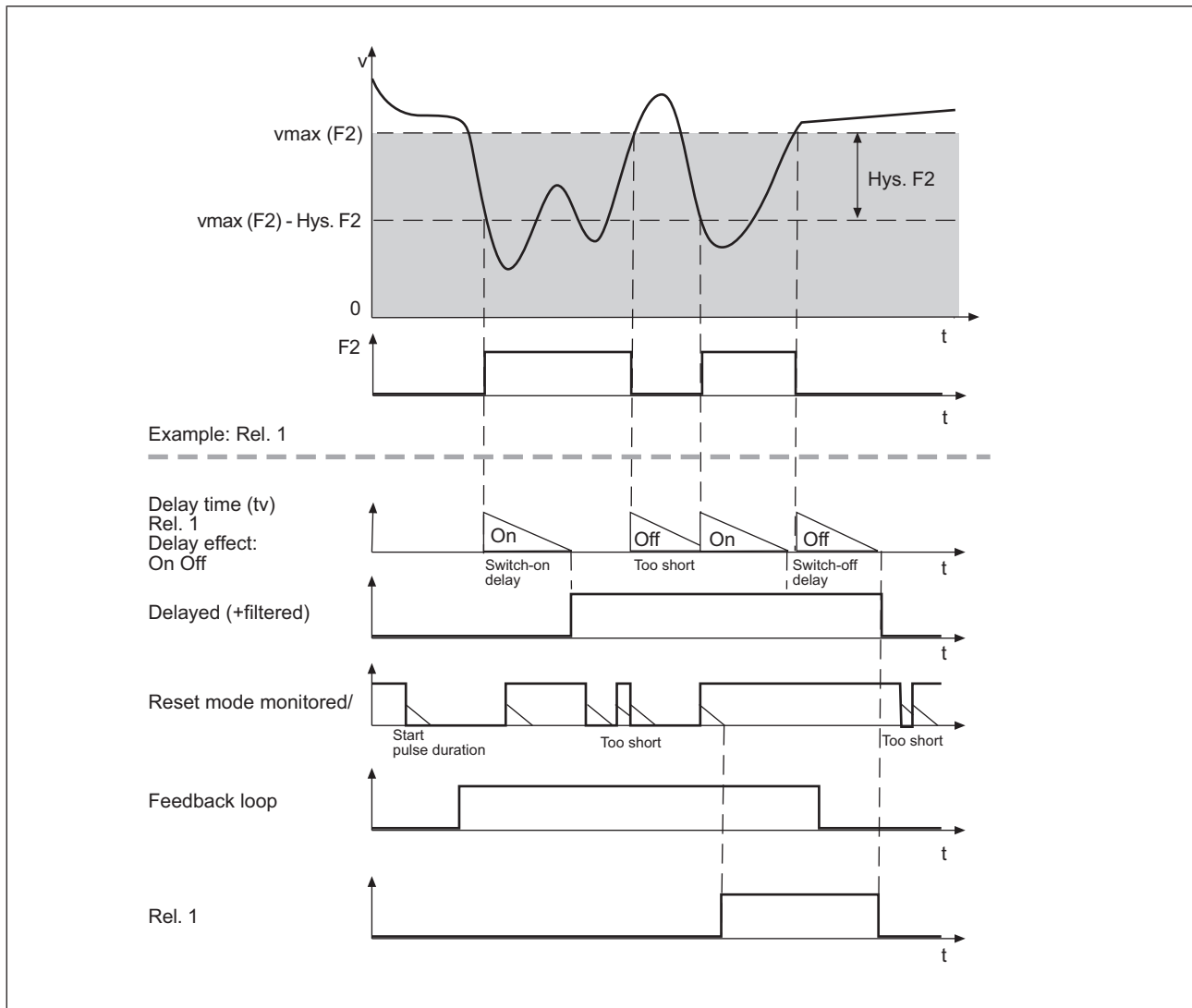

Configuration in the example:

- ▶ Switch function: F2
- ▶ Assigned output: Rel. 1
- ▶ Delay effect on outputs: On + Off
- ▶ Start type: Monitored /

Safety relays PNOZsigma PNOZ s30

Speed configuration

The speed monitor is configured using the rotary knob on the device.

Up to 16 parameter sets (P0 ... P15), each with a max. of 9 switch functions (F1 ... F9) can be configured to monitor various operating modes, for example.

One of the 16 parameter sets is selected via 4 select inputs SEL1 (Y10), SEL2 (Y11), SEL4 (Y12), SEL8 (Y13).

The switch functions are monitored simultaneously.

Each of a switch function's 16 parameters can be configured as

- ▶ Standstill limit
- ▶ Speed limit
- ▶ Upper or lower limit of speed range
- ▶ Right-hand direction monitoring
- ▶ Left-hand direction monitoring
- ▶ Position monitoring 1 to 4 with width of position window 1 to 4

Exactly one switch function can be assigned to each output. The same switch function can be assigned to several outputs. With range monitoring, a range is assigned to an output (F2-F3, F4-F5, F6-F7 or F8-F9).

A switch delay and start mode can be configured for each output.

If only one parameter set is used, configure the mode "Select inputs: None". The select inputs will then be ignored.

Example configuration:

2 parameter sets for 2 operating modes are configured:

- ▶ Set-up: P1
- ▶ Automatic mode: P2

The parameter set P1 is used to monitor a reduced speed.

The parameter set P2, "Automatic mode", is selected for speed monitoring (selection via the select inputs, see next chapter "Select inputs").

The following switch functions are configured for the parameter set P1:

- ▶ F1: Standstill 2 Hz
- ▶ F2: Overspeed: 50 Hz
- ▶ F3: Warning threshold: 50 Hz

The following switch functions are configured for the parameter set P2:

- ▶ F1: Standstill 2 Hz
- ▶ F2: Overspeed: 3000 Hz
- ▶ F3: Warning threshold: 2800 Hz

Safety relays PNOZsigma PNOZ s30

The following outputs are assigned to the switch functions:

- ▶ F1: Relay output Rel. 1
- ▶ F2: Relay output Rel. 2
- ▶ F3: Semiconductor output Out 1

The screenshot shows the configuration software interface for the PNOZsigma relay. It includes several panels for settings:

- language:** English
- input device:** Sin/cos 1Vss
- global standstill:** 2 Hz
- input device settings:** f max (A/B) 20 kHz, f max (Z)
- ratio:** f(A/B):f(Z)
- position window width:** Pos. 1 to Pos. 4
- incorrect direction:** direction left max. right, direction right max. left
- name of configuration:** Example 2
- CRC of configuration:**

The main configuration table is as follows:

| Hysteresis (0-50%) | F1 | F2 | F3 | F4 | F5 | F6 | F7 | F8 | F9 |
|--------------------|------------|---------|---------|----|----|----|----|----|----|
| P0 | | | | | | | | | |
| P1 | Standstill | 50 Hz | 50 Hz | | | | | | |
| P2 | Standstill | 3000 Hz | 2800 Hz | | | | | | |
| P3 | | | | | | | | | |
| P4 | | | | | | | | | |
| P5 | | | | | | | | | |
| P6 | | | | | | | | | |
| P7 | | | | | | | | | |
| P8 | | | | | | | | | |
| P9 | | | | | | | | | |
| P10 | | | | | | | | | |
| P11 | | | | | | | | | |
| P12 | | | | | | | | | |
| P13 | | | | | | | | | |
| P14 | | | | | | | | | |
| P15 | | | | | | | | | |

| | Rel. 1 (13/14) | Rel. 2 (23/24) | Ext. 1 | Ext. 2 | Out 1 (Y32) | Out 2 (Y33) | Out 3 (Y34) | Out 4 (Y35) |
|------------------------------|----------------|----------------|--------|--------|--------------|-------------|-------------|-------------|
| assign outputs (functions) | F1 | F2 | | | F3 | | | |
| delay time effect (outputs) | | | | | | | | |
| delay time 0 - 30s (outputs) | | | | | | | | |
| reset mode | automatic | automatic | | | automatic | | | |
| output out logic | | | | | normally off | | | |

For documentation and a better overview of the device settings, we recommend that you fill in this configuration overview before setting the device parameters.

Select Inputs

The parameter sets are selected via the 4 select inputs SEL1 (Y10), SEL2 (Y11), SEL4 (Y12), SEL8 (Y13). Only one of the configured parameter sets can be selected.

One of the following modes can be selected in the "Select inputs mode" menu, depending on the application:

Safety relays PNOZsigma PNOZ s30

"None" mode

For applications up to PL e of EN ISO 13849-1 and SIL CL 3 of EN IEC 62061.

The select inputs are ignored. Only the parameter set P0 is configured and used. The lowest frequency (10 mHz) is automatically set for all other parameter sets.

"1 from 4" mode

For applications up to PL e of EN ISO 13849-1 and SIL CL 3 of EN IEC 62061.

A maximum of 4 parameter sets can be configured and used: P1, P2, P4 and P8.

| Parameter set | Signal states of the select inputs | | | |
|---------------|------------------------------------|-------------|-------------|-------------|
| | SEL 8 (Y13) | SEL 4 (Y12) | SEL 2 (Y11) | SEL 1 (Y10) |
| P1 | 0 | 0 | 0 | 1 |
| P2 | 0 | 0 | 1 | 0 |
| P4 | 0 | 1 | 0 | 0 |
| P8 | 1 | 0 | 0 | 0 |

When using these 4 parameter sets, the following safety features are met:

If there is an error when activating the select inputs, such as

- ▶ Short circuits and shorts between contacts
- ▶ Open circuit
- ▶ Input drift

a parameter set other than P1, P2, P4 or P8 is selected.

The lowest frequency (10 mHz) is automatically set for the other parameter sets (P0, P3, P5 ... P7, P9 ... P15). If one of these parameter sets is selected, an error message appears and all outputs switch off.

"All 16" mode

In this mode, the number of parameter sets can be increased to max. 16. This mode can only be used for applications up to max. PL d of EN ISO 13849-1 and up to SIL CL 2 of EN IEC 62061.

| Parameter set | Signal states of the select inputs | | | |
|---------------|------------------------------------|-------------|-------------|-------------|
| | SEL 8 (Y13) | SEL 4 (Y12) | SEL 2 (Y11) | SEL 1 (Y10) |
| P0 | 0 | 0 | 0 | 0 |
| P1 | 0 | 0 | 0 | 1 |
| P2 | 0 | 0 | 1 | 0 |
| P3 | 0 | 0 | 1 | 1 |
| P4 | 0 | 1 | 0 | 0 |
| P5 | 0 | 1 | 0 | 1 |
| P6 | 0 | 1 | 1 | 0 |

Safety relays PNOZsigma PNOZ s30

| Parameter set | Signal states of the select inputs | | | |
|---------------|------------------------------------|---|---|---|
| P7 | 0 | 1 | 1 | 1 |
| P8 | 1 | 0 | 0 | 0 |
| P9 | 1 | 0 | 0 | 1 |
| P10 | 1 | 0 | 1 | 0 |
| P11 | 1 | 0 | 1 | 1 |
| P12 | 1 | 1 | 0 | 0 |
| P13 | 1 | 1 | 0 | 1 |
| P14 | 1 | 1 | 1 | 0 |
| P15 | 1 | 1 | 1 | 1 |

When using the expanded parameter sets, please note:

If an open circuit occurs when the select inputs are activated, the system will switch to a parameter set with a lower number (e.g. P7 -> P3 if an open circuit occurs at SEL4). The limit values for the switch functions should therefore be entered in ascending order. (Parameter set P0 -> lowest values, parameter set P15 -> highest values).

Delay on the select inputs

A reaction time can be entered for the select inputs. That way it is possible to filter out invalid signals (e.g. contact bounce or an intermediate state) that occur when switching.

Switch functions

The following switch functions can be configured:

▶ Standstill

The standstill frequency is configured centrally. The standstill frequency should be the lowest frequency in the configuration.

All switch function parameters are pre-configured to the lowest frequency ex works.

▶ Speed

Limit values can be configured to monitor for overspeed.

Limit values should be entered in ascending order (Parameter set P0 -> lowest values, parameter set P15 -> highest values)

▶ Speed range

Up to 4 speed ranges can be monitored simultaneously.

Configure two switch functions to monitor a range:

- F2 and F3,
- F4 and F5,
- F6 and F7 or
- F8 and F9.

Safety relays PNOZsigma PNOZ s30

The switch function with the lower number (e.g. F2) operates as the lower range limit; the switch function with the higher number (e.g. F3) operates as the upper range limit.

Both switch functions can be assigned to one or more outputs.

▶ **Position**

Up to 4 different position windows can be monitored: Position 1 ... Position 4.

Each position to be monitored can be entered as often as necessary in parameter sets P0 to P15 and switch functions F1 to F9.

▶ **Direction**

The monitoring functions "Direct. Left" and "Direct. Right" can be configured as a switch function as often as necessary.

For both directions, a tolerance can be entered for the wrong direction.

Basic configuration

Two basic configurations are available for standard applications, for simple configuration within the display menu. A basic configuration contains limited menu functions adapted for standard applications, with partly pre-defined parameters.

The following basic configurations are available:

Basic configuration 1: Ini pnp pnp (proximity switch)

Pre-defined settings and configuration options:

▶ **Encoder type**

2 pnp type proximity switches

▶ **Switch functions**

– **Standstill (F1)**

– Standstill frequency configurable in Hz

– **Speed (F2)**

– Max. frequency (v max) configurable in Hz

▶ **Parameter set/select input**

P0, select inputs are ignored ("None" mode")

▶ **Hysteresis**

Standstill and speed, 2 % each

▶ **Output assignment**

– Standstill: Relay output Rel. 1 and semiconductor output Out 1

– Speed: Relay output Rel. 2 and semiconductor output Out 2

▶ **Reset mode**

– Rel. 1, Rel. 2 Out 1, Out 2: Automatic reset

▶ **Switch delay**

None

Safety relays PNOZsigma PNOZ s30

▶ **Max. encoder frequency**

3.5 kHz

Basic configuration 2: Rotary encoder

▶ **Encoder type**

Rotary encoders

- Rotary encoder type configurable

▶ **Switch functions**

– **Standstill (F1)**

- Standstill frequency configurable in Hz

– **Speed (F2)**

- Max. frequency (v max) configurable in Hz

– **Direction (F3)**

Direction left

Tolerance for wrong direction = 10 Imp

– **Direction (F4)**

Direction right

Tolerance for wrong direction = 10 Imp

▶ **Parameter set/select input**

P0, select inputs are ignored ("None" mode")

▶ **Hysteresis**

Standstill and speed, 2 % each

▶ **Output assignment**

- Standstill: Relay output Rel. 1 and semiconductor output Out 1
- Speed: Relay output Rel. 2 and semiconductor output Out 2
- Direction left: External output Ext. 1 and semiconductor output Out 3
- Direction right: External output Ext. 2 and semiconductor output Out 4

▶ **Reset mode**

- All outputs: Automatic reset

▶ **Switch delay**

None

▶ **Max. encoder frequency**

1 MHz

Safety relays PNOZsigma PNOZ s30

Chip card

The set parameters, the name of the configuration, the check sum and the passwords are stored on the chip card (see section entitled "Using the chip card").

Input device types

Proximity switch

- ▶ The following proximity switches can be used:
 - pnp
 - npn
- ▶ The proximity switches must be fitted so that at least one is always activated. In other words, the proximity switches must be fitted so that the recorded signals always overlap.
- ▶ The cable used to connect the proximity switches must be shielded (see connection diagrams in the chapter entitled "EMC-compliant wiring").
- ▶ The supply voltage of the proximity switches should be monitored via track S.

Proximity switch assembly:

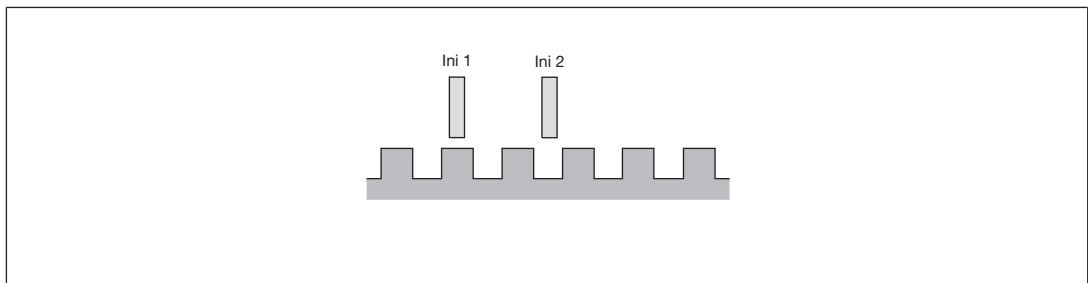

Example pnp – pnp:

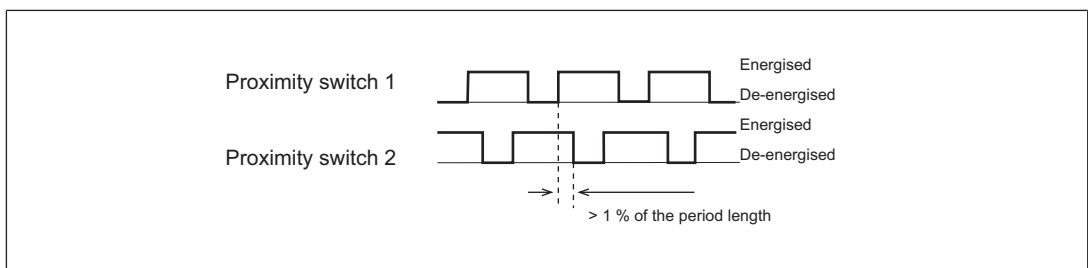

- ▶ Please note the values stated in the technical details
- ▶ The maximum frequency of the used encoders must be entered for a complete configuration ("Encoder" Menu -> "Track AB" -> "Track AB fmax" / "Track Z" -> "Track Z fmax").

Safety relays PNOZsigma PNOZ s30

Rotary encoders

- ▶ The following rotary encoders can be used:
 - TTL, HTL (single-ended or differential signals)
 - sin/cos 1 Vss
 - Hiperface
- ▶ The rotary encoders can be connected with or without Z index (0 index)
- ▶ The cable used to connect the rotary encoders must be shielded (see connection diagrams in the chapter entitled "EMC-compliant wiring").
- ▶ A proximity switch can also be connected to track Z for monitoring broken shearpins
- ▶ Track S can be used:
 - To connect an encoder's error output
 - To monitor voltages between 0 V and 30 V for a permitted upper and lower limit. For example, the encoder's supply voltage can be monitored.
- ▶ The following must be entered for a complete configuration:
 - The maximum frequency of the used encoders ("Encoder Settings" menu -> "Track AB" -> "Track AB fmax" / "Track Z" -> "Track Z fmax").
 - The ratio fAB/fZ ("Encoder Settings" menu -> "Track Z" -> fAB/fZ Verh.)

Please note the values stated in the technical details

Safety relays PNOZsigma PNOZ s30

Output signals

Output signals TTL, HTL

- ▶ Single ended

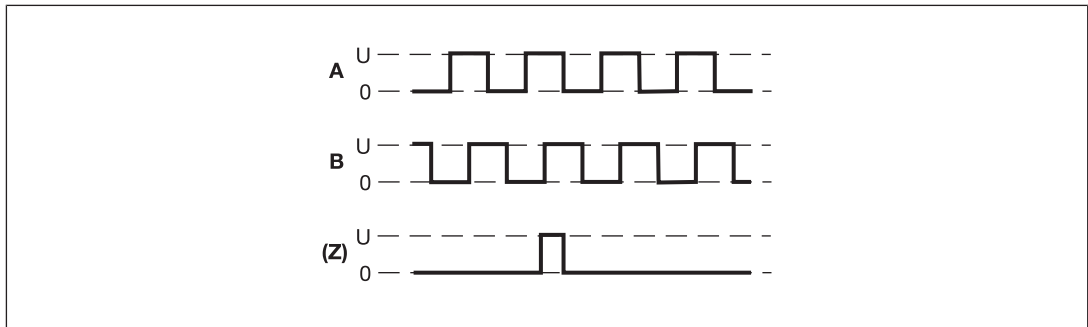

- ▶ Differential

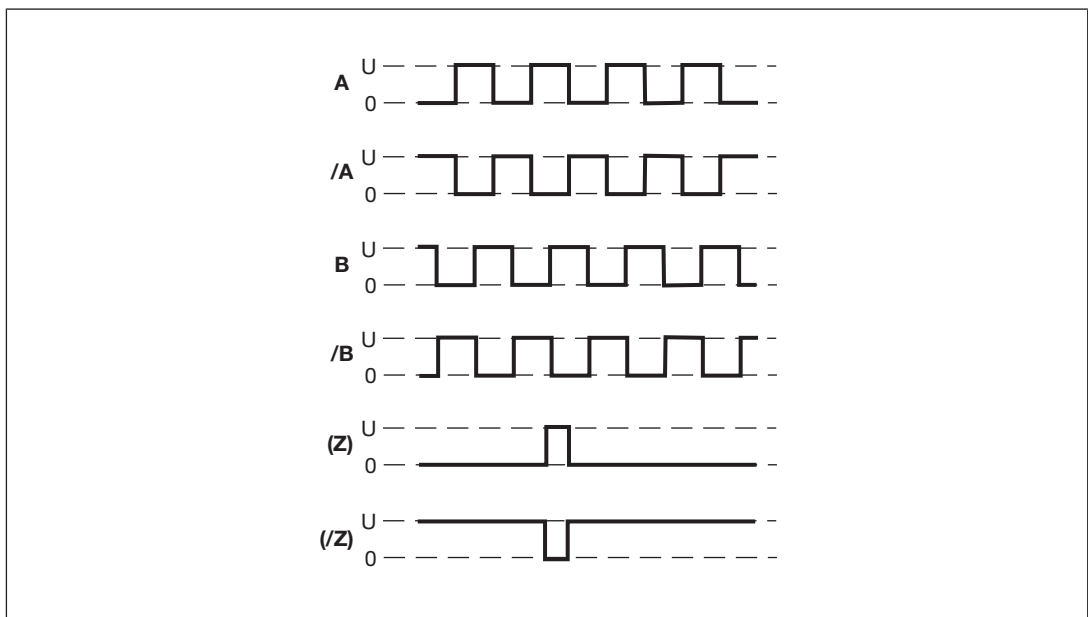

Safety relays PNOZsigma PNOZ s30

Output signals Sin/Cos (1 Vss)

- ▶ Single ended with reference track (e.g. Hiperface ®)

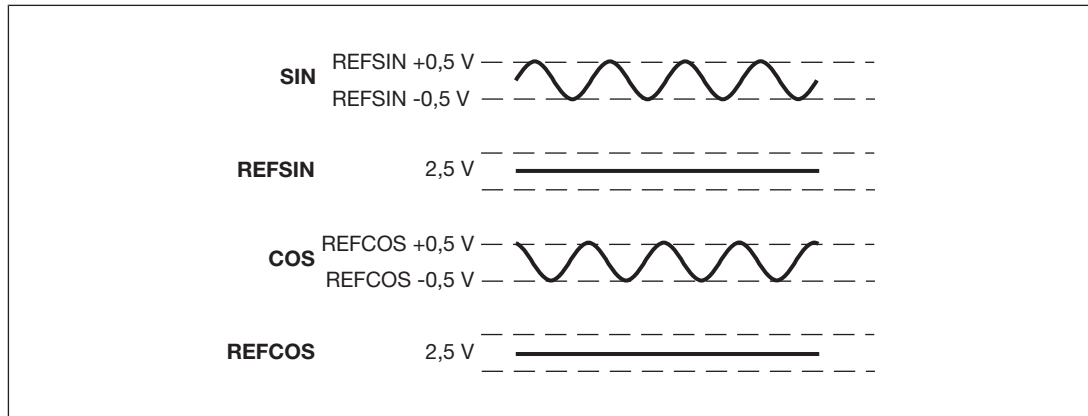

- ▶ Differential with/without Z index (e.g. Heidenhain 1 Vss)

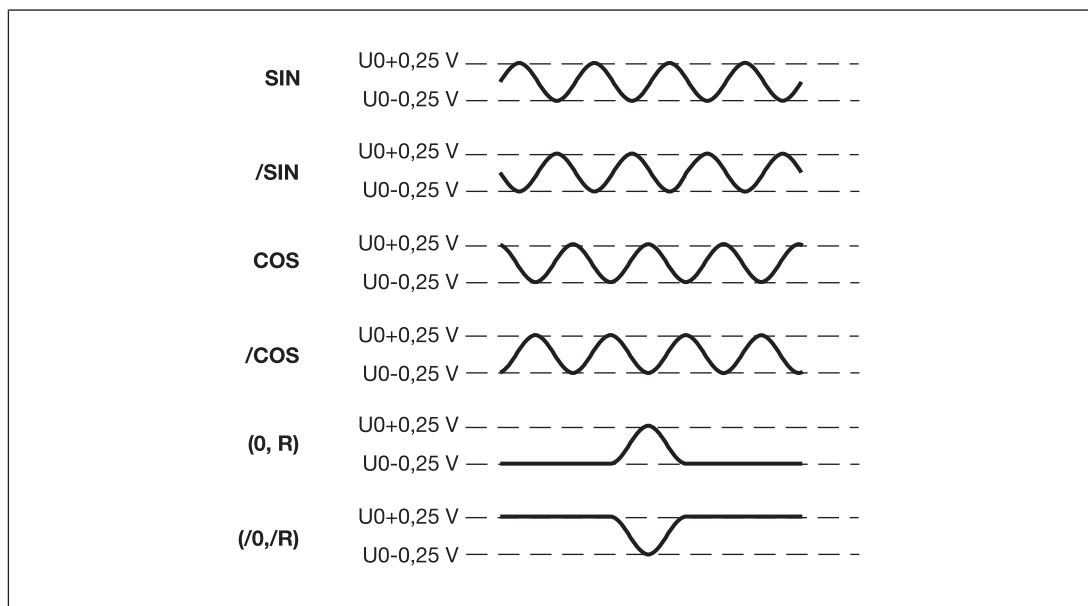

Adapter for incremental encoders

The adapter records the data between the encoder and the drive and makes it available to the PNOZ s30 via the RJ45 socket.

Pilz supplies complete adapters as well as ready-made cable with RJ45 connector, which can be used when making your own adapter. The range of products in this area is constantly being expanded. Please contact us about the range of adapters that is currently available.

Safety relays PNOZsigma PNOZ s30

Installation

General installation guidelines

Install base unit without contact expansion module:

- ▶ Ensure that the plug terminator is inserted at the side of the unit.

Connect base unit and PNOZsigma contact expansion module:

- ▶ Remove the plug terminator at the side of the base unit and at the contact expander module.
- ▶ Connect the base unit and the contact expander module to the supplied connector before mounting the units to the DIN rail.

Control cabinet installation

- ▶ The unit should be installed in a control cabinet with a protection type of at least IP54.
- ▶ It is preferable to install the device on a horizontal DIN rail in order to ensure the best possible convection.
- ▶ Use the notch on the rear of the unit to attach it to the DIN rail.
- ▶ Push the device upwards or downwards before lifting it from the DIN rail.

Dimensions

*with spring-loaded terminals

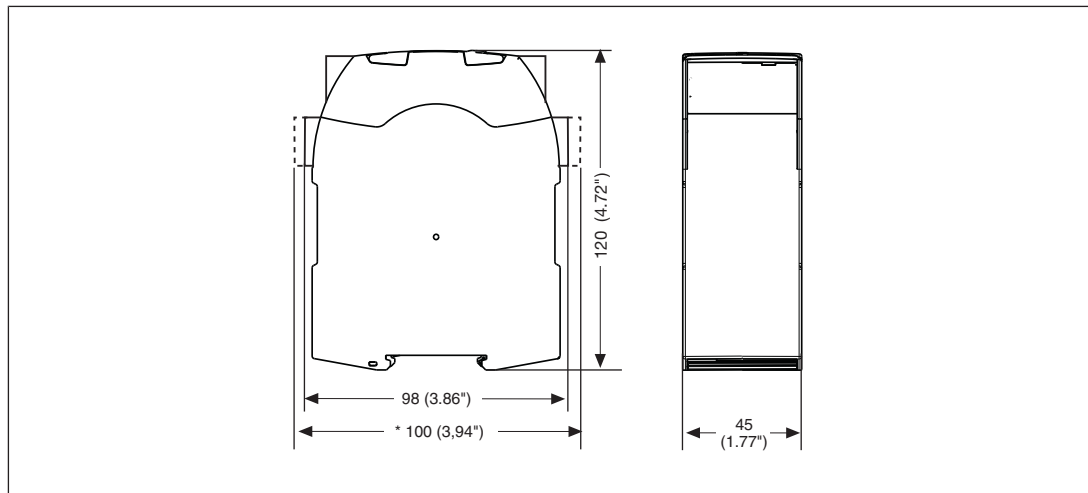

Safety relays PNOZsigma PNOZ s30

Commissioning

Wiring

General wiring guidelines

Note:

- ▶ Information given in the "Technical details" must be followed.
- ▶ Use copper wire that can withstand 75 °C.
- ▶ The cable used to connect the encoders and proximity switches must be shielded (see connection diagrams in the chapter entitled "EMC-compliant wiring").
- ▶ The shield may only be connected to earth at a single point.
- ▶ Earth loops should be avoided.
- ▶ If possible, the connections for the various earth potentials (GND, S21, Y30, A2) should not be connected on the PNOZ s30 but should be connected directly to the GNDs on the connected units, otherwise noise susceptibility may be increased significantly (conductor loops are not permitted).

Pin assignment of RJ45 socket

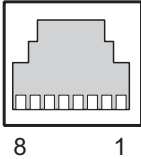
| RJ45 socket 8-pin | PIN | Track |
|---|-----|-------|
|  | 1 | S |
| | 2 | GND |
| | 3 | Z |
| | 4 | A |
| | 5 | /A |
| | 6 | /Z |
| | 7 | B |
| | 8 | /B |

Supply voltage

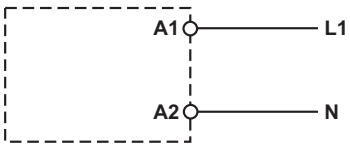
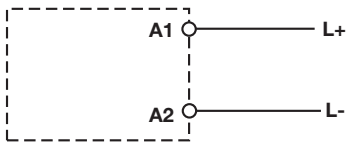
| Supply voltage | AC | DC |
|----------------|--|---|
| |  |  |

Safety relays PNOZsigma PNOZ s30

Connection of proximity switches

The following proximity switch combinations can be connected:

- ▶ A: pnp, B: pnp
- ▶ A: npn, B: npn
- ▶ A: pnp, B: npn
- ▶ A: npn, B: pnp

When connecting proximity switches please note:

- ▶ Proximity switches can either be connected to terminals IN1, IN2 and GND or to tracks A and B plus GND on the RJ45 socket.
- ▶ Track S should be used to monitor the supply voltage (see drawing). A permitted voltage range can be entered in the menu.
- ▶ Connect the proximity switch to 24 VDC of the power supply.
- ▶ When connecting the proximity switches, please refer to the chapter entitled "EMC-compliant wiring"
- ▶ Invalid signals may occur with cable lengths >50 m. In this case we recommend that you connect a resistor between the signal lines, as shown in the diagrams.

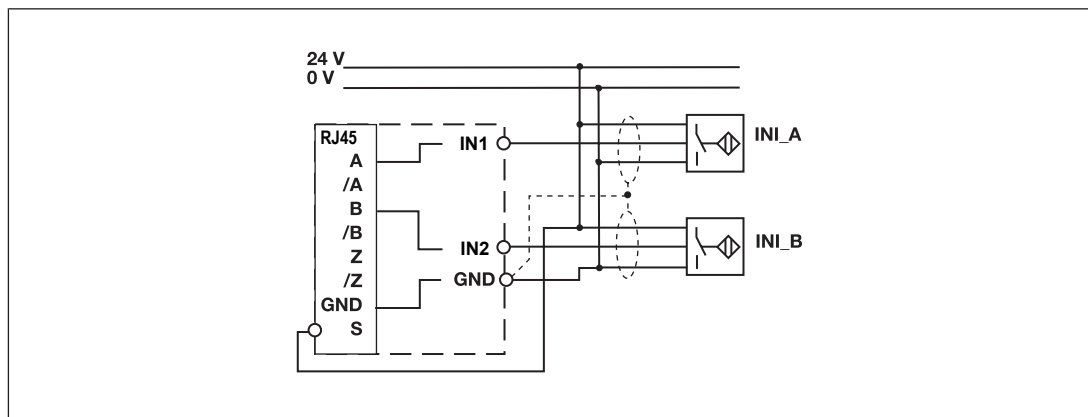

pnp proximity switch with resistor R = 10 kOhm

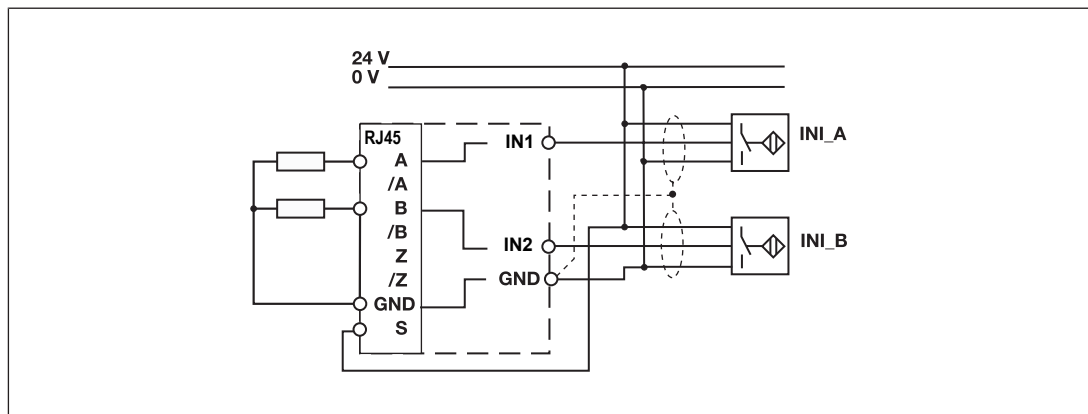

Safety relays PNOZsigma PNOZ s30

npn proximity switch with resistor $R = 47\text{ k}\Omega$

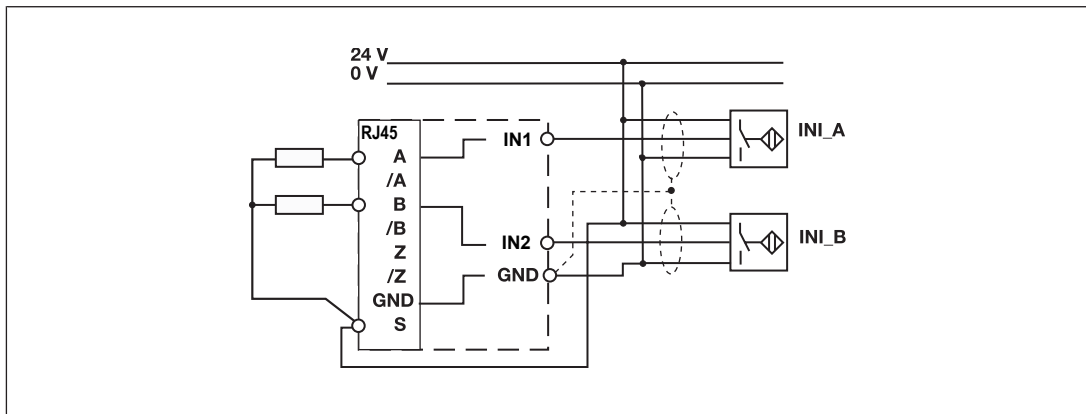

Connection of a rotary encoder

Proceed as follows when connecting the encoder:

- ▶ The encoder can be connected via an adapter (e.g. PNOZ msi6p) or directly to the PNOZ s30.
- ▶ Use only shielded cables for all connections. Please refer to the chapter entitled "EMC-compliant wiring".
- ▶ Always connect GND on the encoder to GND on the RJ45 connector.

Connect rotary encoder to speed monitor

Encoder types:

- ▶ TTL single ended
- ▶ HTL single ended

Please note:

- ▶ Tracks/A, /B, Z and /Z must remain free

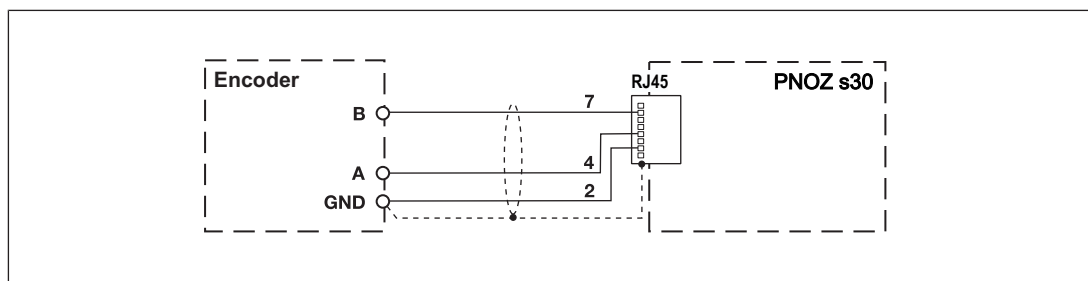

Safety relays PNOZsigma PNOZ s30

Encoder types:

- ▶ TTL Differential
- ▶ HTL differential
- ▶ sin/cos 1 Vss
- ▶ Hiperface

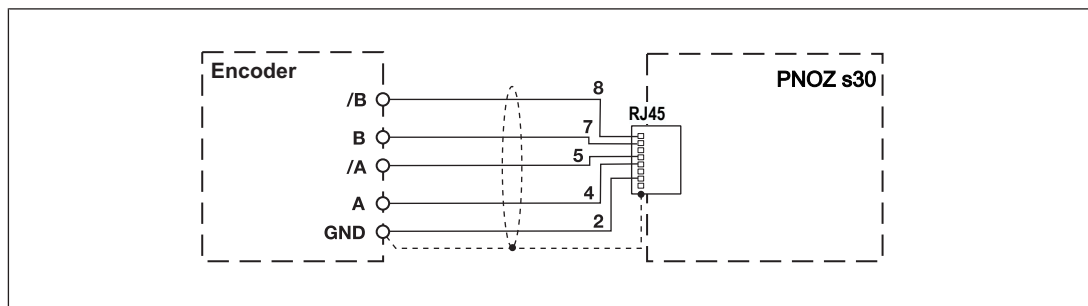

Connect rotary encoder with Z index to speed monitor

Encoder types:

- ▶ TTL single ended Z Index
- ▶ HTL single ended Z Index

Please note:

- ▶ Tracks /A, /B and /Z must remain free

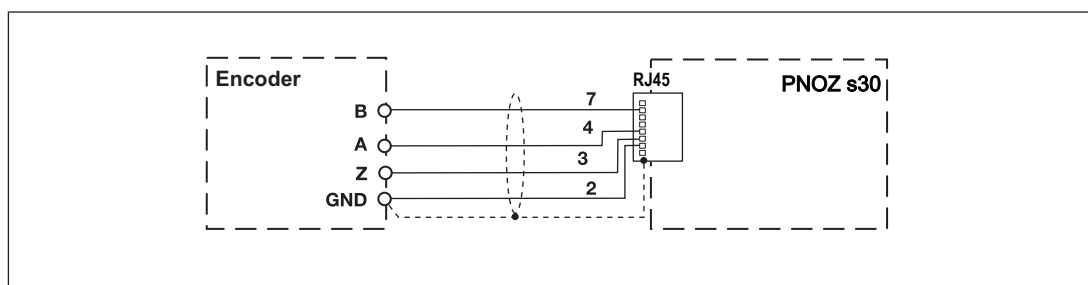

Encoder types:

- ▶ TTL differential + Z Index
- ▶ HTL differential + Z Index
- ▶ sin/cos 1 Vss Z Index

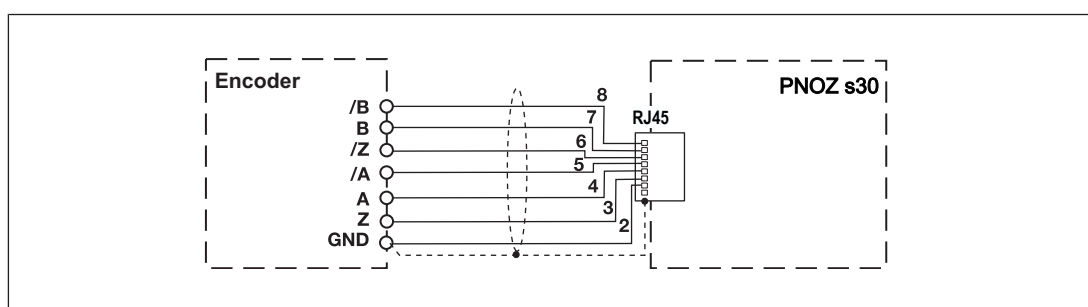

Safety relays PNOZsigma PNOZ s30

Connect rotary encoder to the speed monitor via an adapter

The adapter (see Accessories) is connected between the encoder and the drive. The output on the adapter is connected to the RJ45 socket on the PNOZ s30.

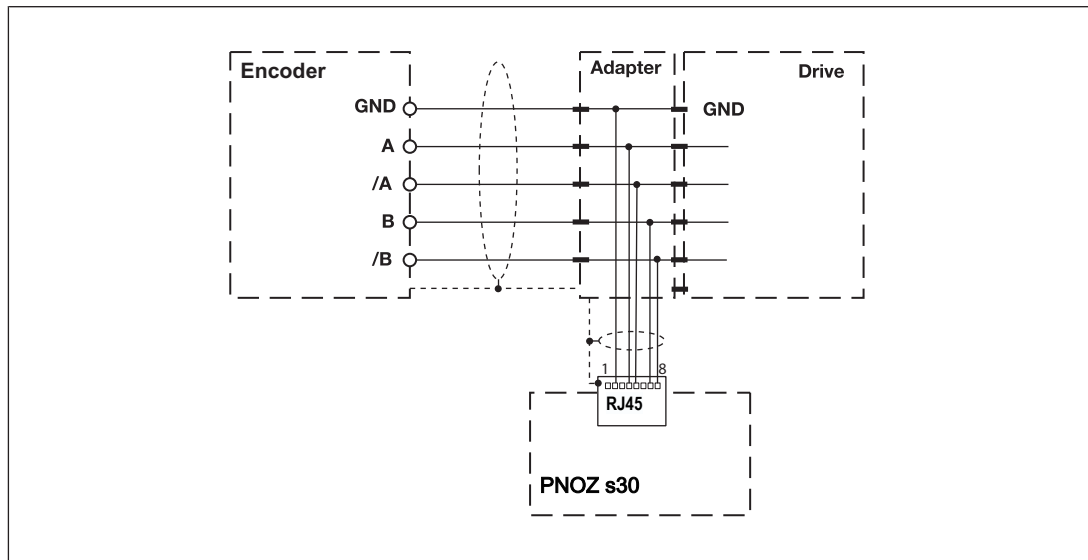

Connection of proximity switch and rotary encoder

When connecting the encoders and proximity switches, please refer to the chapter entitled "EMC-compliant wiring".

Sensor types:

- ▶ Configuration: HTL single Z Freq. Ini pnp
 - HTL single ended (A,B) + Ini pnp (Z)
 - HTL single ended (A,B) + HTL differential (A as Z)
 - HTL single ended (A,B) + HTL single ended (A as Z)
- ▶ Configuration: TTL single Z Freq. Ini pnp
 - TTL single ended (A,B) + Ini pnp (Z)
 - TTL single ended (A,B) + HTL differential (A as Z)
 - TTL single ended (A,B) + HTL single ended (A as Z)

Safety relays PNOZsigma PNOZ s30

Please note:
Tracks /A, /B and /Z must remain free.

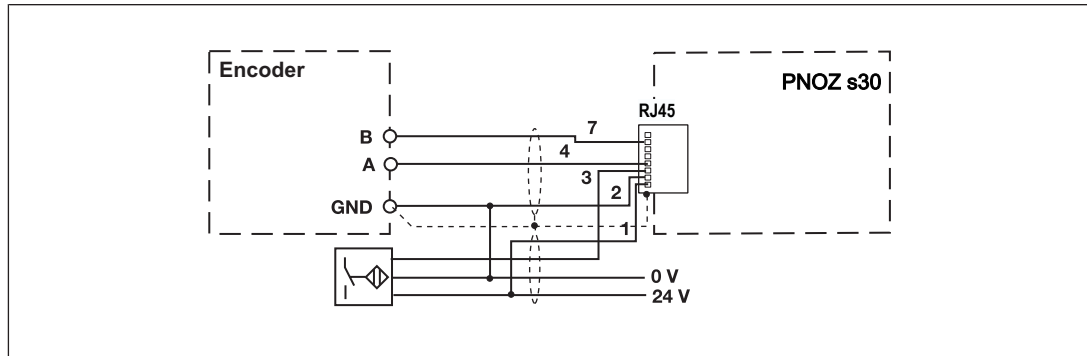

Sensor types:

- ▶ Configuration: TTL differential Z Freq. Ini pnp
 - TTL differential (A,/A,B,/B) + Ini pnp (Z)
 - TTL differential (A,/A,B,/B) + HTL differential (A as Z)
 - TTL differential (A,/A,B,/B) + HTL single ended (A as Z)
- ▶ Configuration: HTL differential Z Freq. Ini pnp
 - HTL differential (A,/A,B,/B) + Ini pnp (Z)
 - HTL differential (A,/A,B,/B) + HTL differential (A as Z)
 - HTL differential (A,/A,B,/B) + HTL single ended (A as Z)
- ▶ Configuration: sin/cos 1 Vss Z Freq. Ini pnp
 - sin/cos 1 Vss (A,/A,B,/B) + Ini pnp (Z)
 - sin/cos 1 Vss (A,/A,B,/B) + HTL differential (A as Z)
 - sin/cos 1 Vss (A,/A,B,/B) + HTL single ended (A as Z)
- ▶ Configuration: Hiperface Z Freq. Ini pnp
 - Hiperface (A,/A,B,/B) + Ini pnp (Z)
 - Hiperface (A,/A,B,/B) + HTL differential (A as Z)
 - Hiperface (A,/A,B,/B) + HTL single ended (A as Z)

Safety relays PNOZsigma PNOZ s30

Please note:
Track /Z must remain free!!

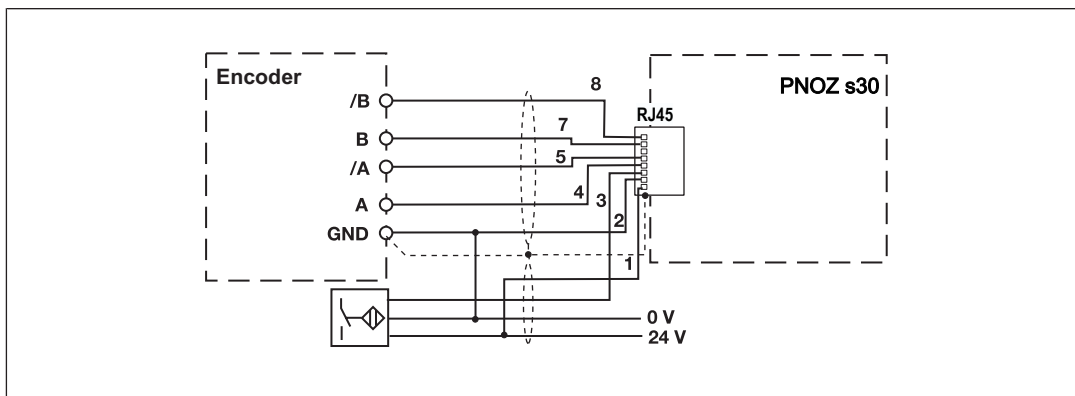

Reset circuit

| Automatic start | Monitored start |
|---|-----------------|
| automatic start must only be configured No wiring necessary! | |

Feedback circuit

| No feedback loop monitoring | Contacts from external contactors |
|-----------------------------|-----------------------------------|
| | |

Select inputs

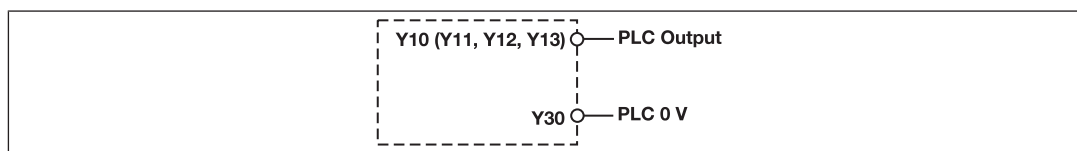

Safety relays PNOZsigma PNOZ s30

Semiconductor outputs

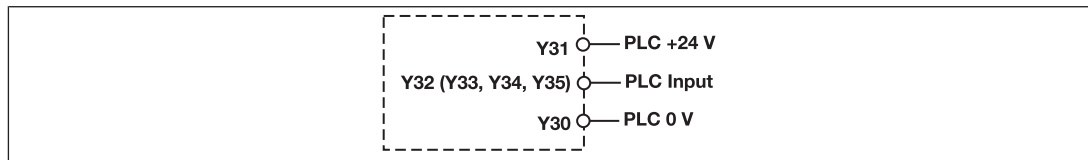

EMC-compliant wiring

EMC-compliant wiring for connecting an encoder

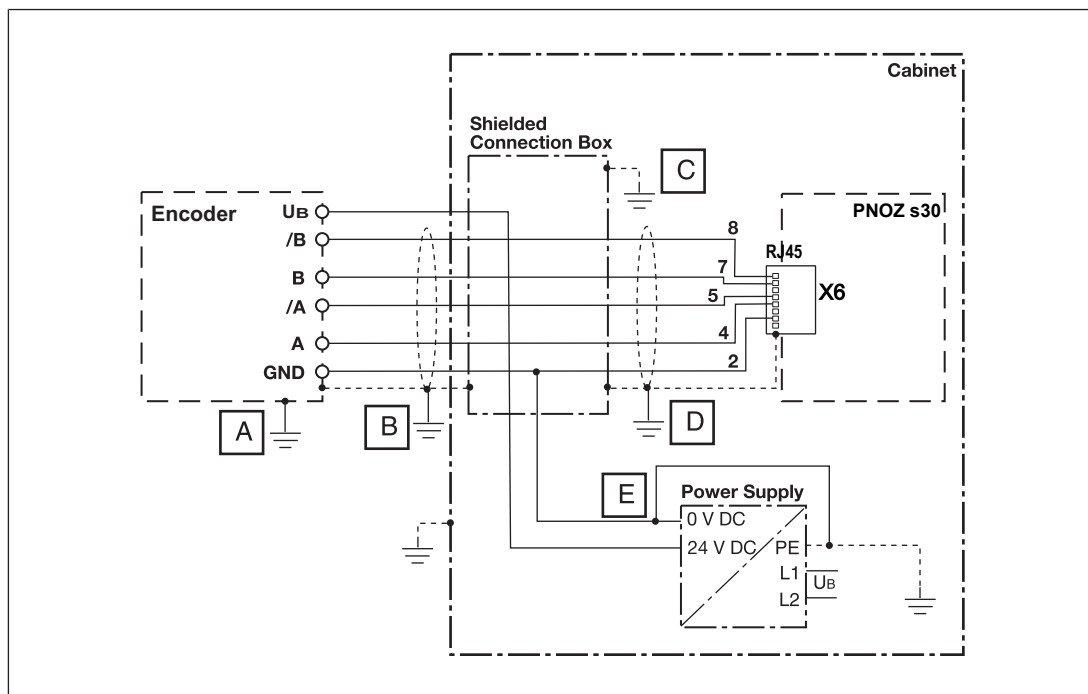

To avoid EMC interference we recommend that the shield on the sensor cables or the housing of the shielded junction box is only connected to earth at a single point:

A or B or C or D or E

Conductor loops outside the shield must be avoided.

If a shielded junction box is not used, the shield must run continuously from the sensor to the evaluation device.

Safety relays PNOZsigma PNOZ s30

EMC-compliant wiring for connecting an encoder with drive

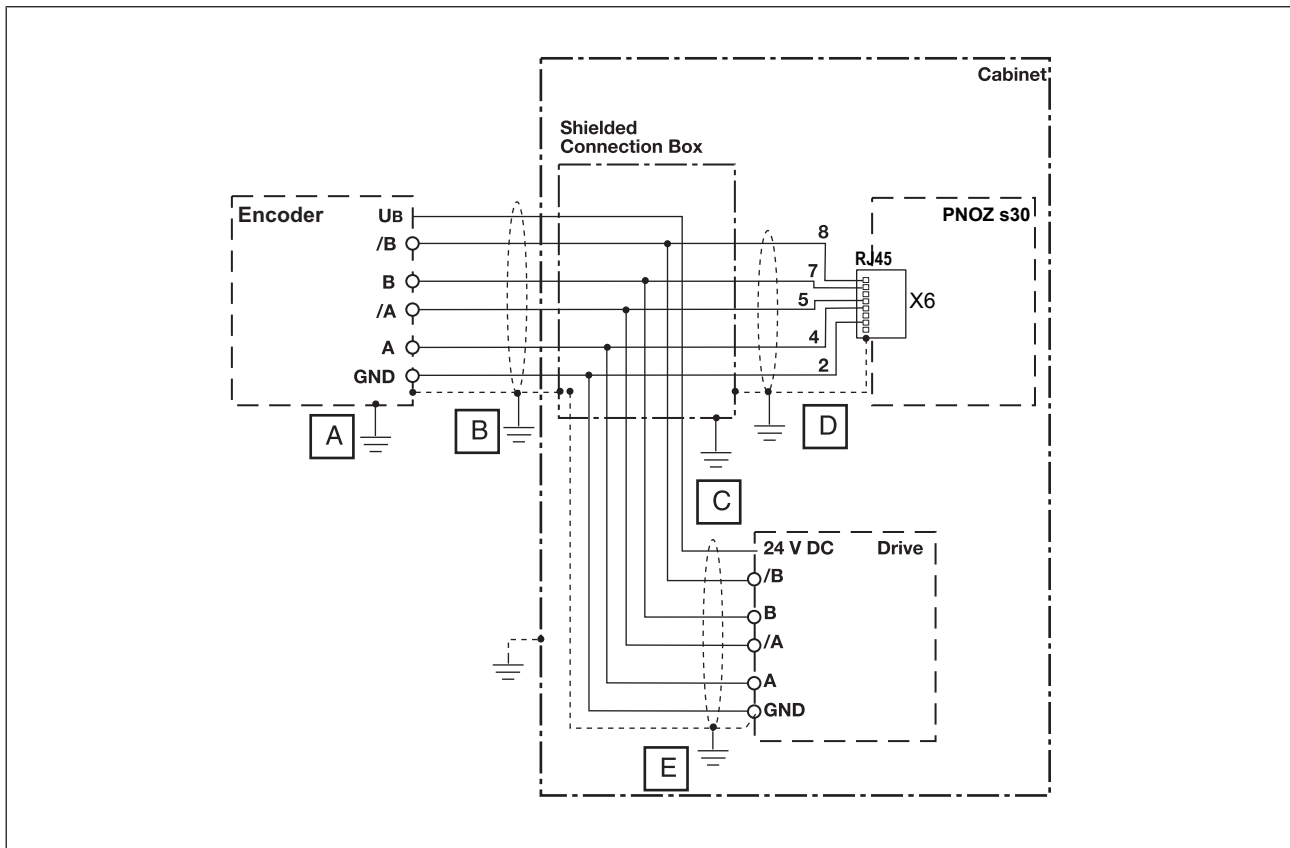

To avoid EMC interference we recommend that the shield on the sensor cables or the housing of the shielded junction box is only connected to earth at a single point:

A or B or C or D or E

Conductor loops outside the shield must be avoided.

If a shielded junction box is not used, the shield must run continuously from the sensor to the evaluation device.

Safety relays PNOZsigma PNOZ s30

EMC-compliant wiring for connecting 2 proximity switches

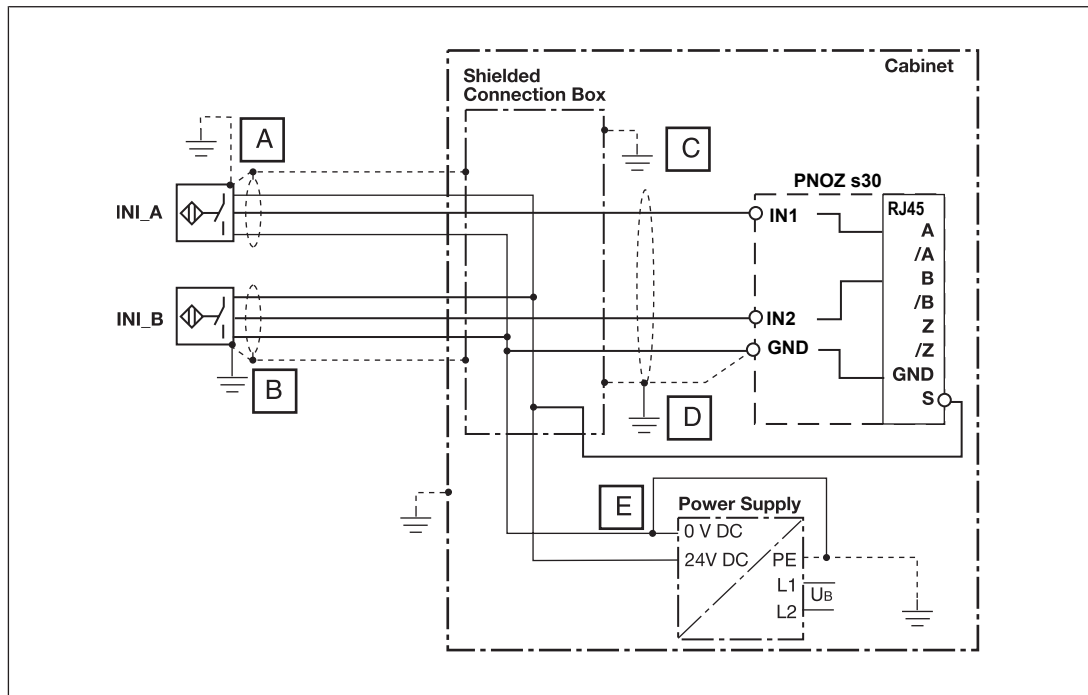

To avoid EMC interference we recommend that the shield on the sensor cables or the housing of the shielded junction box is only connected to earth at a single point:

A or B or C or D or E

Conductor loops outside the shield must be avoided.

If a shielded junction box is not used, the shield must run continuously from the sensor to the evaluation device.

Safety relays PNOZsigma PNOZ s30

Display menu - Configuration

The menu settings are made on the unit's display via a rotary knob. You have the option to make the settings on the knob by hand or with a screwdriver. If you make the settings with a screwdriver, the knob can remain within the unit.

Create configuration overview

For a better overview, before entering the configuration values we recommend that they are entered in the form *PNOZ_s30_Config_Overview*.

| | | | | | | | | | | | |
|---------------------------------|-----------------------|-------------------|-------------------|--------|--------|----------------|----------------|----------------|----------------|----|--|
| language | input device | | | | | | | | | | global standstill (10 mHz - 1 MHz) |
| delay time start-up (0-600s) | Hysteresis (0-50%) | F1 | F2 | F3 | F4 | F5 | F6 | F7 | F8 | F9 | input device settings (10 mHz-1 MHz) |
| units | P0 | | | | | | | | | | f max (A/B) |
| conversion | P1 | | | | | | | | | | f max (Z) |
| mode select input | P2 | | | | | | | | | | ratio (0,0001-400.000:1) |
| Sel 1 (Y10) | P3 | | | | | | | | | | f(A/B):f(Z) |
| Sel 2 (Y11) | P4 | | | | | | | | | | position window width (1-24.900.000 Imp) |
| Sel 3 (Y12) | P5 | | | | | | | | | | Pos. 1 |
| Sel 4 (Y13) | P6 | | | | | | | | | | Pos. 2 |
| delay time select input (0-30s) | P7 | | | | | | | | | | Pos. 3 |
| | P8 | | | | | | | | | | Pos. 4 |
| | P9 | | | | | | | | | | incorrect direction (max. wrong) direction (1-24.900.000 Imp) |
| | P10 | | | | | | | | | | direction left |
| | P11 | | | | | | | | | | max. right |
| | P12 | | | | | | | | | | direction right |
| | P13 | | | | | | | | | | max. left |
| | P14 | | | | | | | | | | name of configuration |
| | P15 | | | | | | | | | | CRC of configuration |
| | | Rel. 1 (13/14) | Rel. 2 (23/24) | Ext. 1 | Ext. 2 | Out 1 (Y32) | Out 2 (Y33) | Out 3 (Y34) | Out 4 (Y35) | | |
| assign outputs (functions) | | | | | | | | | | | |
| delay time effect (outputs) | | | | | | | | | | | |
| delay time 0 - 30s (outputs) | | | | | | | | | | | |
| reset mode | | | | | | | | | | | |
| output out logic | | | | | | | | | | | |

Safety relays PNOZsigma PNOZ s30

Operate rotary knob

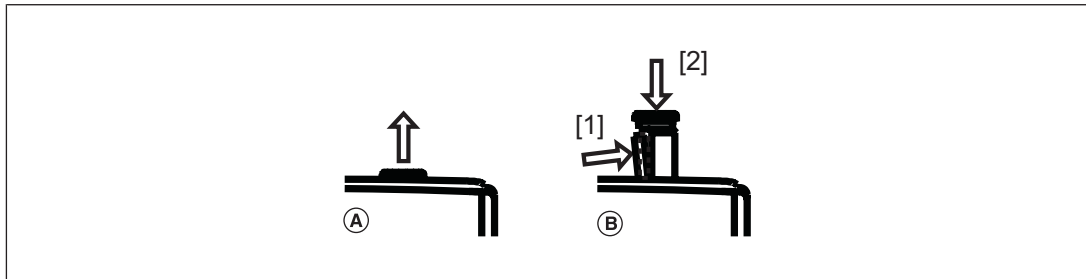

Pull out knob (A):

- ▶ until it locks into position
- ▶ Release knob (B) and push it back into the unit:
 - Press the bar on the side of the knob [1] towards the centre of the knob. This releases the knob.
 - Press the knob downwards [2] while keeping the bar pressed in

Configure Speed Monitor

The settings are made via the rotary knob, as follows:

Press the knob

- ▶ Confirm selection/setting
- ▶ Switch to menu

Rotate knob

- ▶ Select menu level
- ▶ Set the parameter/numeric value

The speed with which you turn the knob affects the sequence of the menu and numeric values:

- ▶ Slowly: Units
- ▶ Quickly: Tens
- ▶ Very quickly:
 - Setting the numeric value: Hundreds
 - When switching the menu level: Jump to **ESCAPE**



Safety relays PNOZsigma PNOZ s30

Password protection

The configuration is protected through passwords. There is a master password and a customer password.

Factory setting for both passwords: 0000

The password levels contain different authorisations:

▶ Master password

Display: All settings

Edit: All settings

▶ Customer password

Display: All settings

Edit:

- The customer password can be changed.
- The language can be changed.
- The settings can be reset to the factory settings.

▶ No password

Edit:

- The language can be changed.
- The settings can be reset to the factory settings.

If the settings are reset to the factory settings, the passwords and the language will also be reset to the factory settings.

The passwords can be changed at any time in the menu.

Enter a password containing 4 characters.

Use chip card

The parameters that are set on a unit can be stored on the chip card. The data is stored along with a device identifier, the passwords, the name of the configuration and the check sum. We recommend that you **always** operate the unit with a chip card.

- ▶ If the parameters on a device have been changed due to an error, they can be restored using the backup copy on the chip card.
- ▶ If a unit requires maintenance or needs to be exchanged, the chip card can be used to download the parameters to another unit.

When the chip card is inside the unit:

- ▶ The chip card is checked to verify the device identifier, valid parameters, and ensure that the data is identical.
- ▶ Unit parameters are automatically saved to the chip card during operation. As a result, the chip card always contains a copy of the unit's current internal data. Exception: If you select **Write configuration to SIM: No**.

Safety relays PNOZsigma PNOZ s30

Insert chip card

Make sure that you do not bend the chip card as you insert it into the chip card slot.

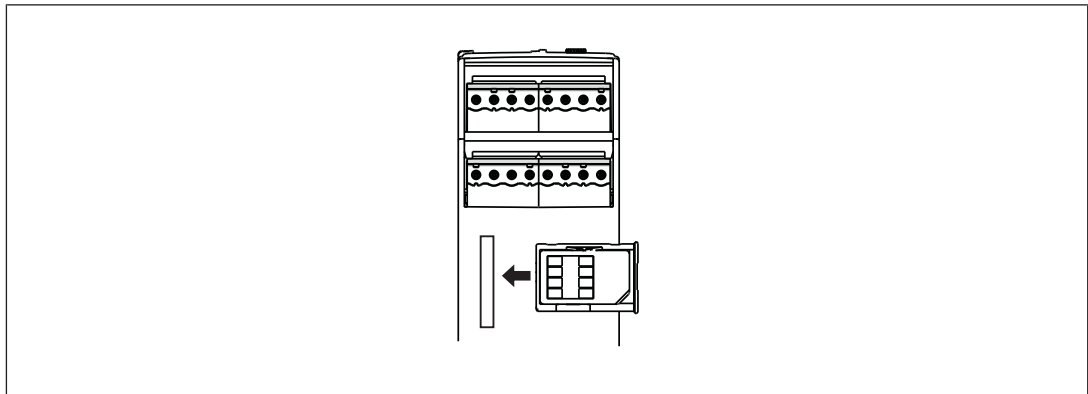

Write data to chip card

If you are inserting a chip card which has not yet been written by a PNOZ s30, you have the option to:

| | | | | | |
|--------------------------------|--|----|---|----|----------------------------------|
| | Insert chip card | 1. | | 2. | Data is written to the chip card |
| Please insert SIM Card! | Write configuration to SIM: No? | | Write configuration to SIM: Yes? | | Current menu |

Allow data to be written to the chip card



| | | | |
|--------------------------------|--|----|---|
| | Insert chip card | 1. | Data is not written to the chip card |
| Please insert SIM Card! | Write configuration to SIM: No? | | Insert rewritable SIM Card! |

Do not allow data to be written to the chip card

Safety relays PNOZsigma PNOZ s30

Read data from chip card

If you are inserting a chip card which has not yet been written by a PNOZ s30, you have the option to:

| | | | | | |
|---------------------|--|---|---|---|------------------------------|
| | Insert chip card (data on chip card different from device) | 1. | | 2. | Data is read into the device |
| Current menu | SIM: Name of the configuration (8 characters) CRC: 12345 (0 .. 65535) Load SIM: No? |  | SIM: Name of the configuration (8 characters) CRC: 12345 (0 .. 65535) Load SIM: Yes? |  | Current menu |

Allow data to be read from the chip card

| | | | |
|---------------------|--|---|--|
| | Insert chip card (Data on chip card different from device) | 1. | Data is not read into the device, data is written to the chip card |
| Current menu | SIM: Name of the configuration (8 characters) CRC: 12345 (0 .. 65535) Load SIM: No? |  | Write configuration to SIM: No? (for more details see "Write data to chip card") |

Do not allow data to be read from the chip card

Transfer device parameters

You can transfer device parameters from one device to another using the chip card.

Proceed as follows:

- ▶ Remove chip card containing the data from device 1.
- ▶ Insert chip card in device 2.
- ▶ Confirm the message **Load SIM Yes?**.
The data is transferred.

Safety relays PNOZsigma PNOZ s30

Duplicate chip card

You can also create copies of a chip card and its data.

Proceed as follows:

- ▶ Remove chip card containing the device data.
- ▶ Insert a new chip card into the device.
- ▶ Confirm the message **Write configuration to SIM Yes?**.
- ▶ The new chip card is written.

Save configuration with Software SmartCardCommander

You have the option to save a PNOZ s30 configuration from the chip card to your computer. The configuration can be saved on the computer and then downloaded to other chip cards.

To do this you will need the chip card reader **PNOZ Chip Card Reader** with the corresponding **SmartCardCommander** software. Both are available from Pilz as accessories, individually or as part of a set (see [Accessories \[891\]](#)).

Save PNOZ s30 configuration on the computer

1. Make a note of the configuration's CRC in the PNOZ s30. It is shown on the display in the **Information/ Configuration CRC** menu. This will be needed later to check whether the correct configuration is saved on the device.
2. Remove the chip card from the PNOZ s30 and insert it into the holder for the chip card reader.
3. Start the **SmartCardCommander** software.
4. Insert the holder containing the chip card into the chip card reader.
5. The **Memory Card** directory is displayed in a list under **Hardware** on the software interface of the **SmartCardCommander**.

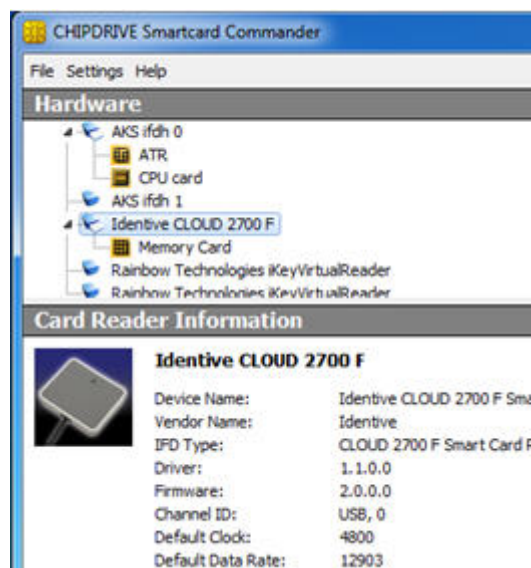

Safety relays PNOZsigma PNOZ s30

6. To read the data on the chip card, click on the **Memory Card** directory and then select **Read Data from Card**.
7. When **Data read successfully** is displayed on the software interface, the data can be saved as a hex file in any directory on the computer.
8. Make sure that the corresponding configuration CRC, which you noted down, is saved in the same directory.

Download configuration from the computer to the PNOZ s30

1. Insert a chip card into the holder for the chip card reader and insert this into the chip card reader.
2. Start the **SmartCardCommander** software.
3. To write the chip card, select **Write Data to Card** and confirm with **Yes**.
4. Insert the chip card in the PNOZ s30 and proceed as described under [Read data from chip card \[📖 846\]](#).
5. To ensure that the configuration has been transferred correctly, check that the CRC for the configuration in the PNOZ s30 matches the configuration CRC you noted down on the computer.

Menu overview

The tables provide an overview of the menu settings.

The Excel file provides a detailed view of the setting options:

PNOZ_s30_Menu_Overview.

Permanent display

If no settings are made, information regarding the configuration and current values are shown on the display.

You can change the permanent display on the display in the "Settings" menu.

Safety relays PNOZsigma PNOZ s30

Basic settings Ini pnp pnp

Settings for basic configuration 1

| Level | Designation on the display | Description | Settings |
|-------|--|---|---------------------|
| 1 | Basic Parameter Ini pnp pnp Default Load? | Select the default settings with which the basic configuration menu Ini pnp pnp is to be called: -Load : The basic parameters are loaded. Then it switches to the basic menu Ini pnp pnp . The basic parameters should always be loaded when commissioning for the first time. - Edit: The basic parameters are not loaded, i.e. all parameters are retained. The basic menu parameters can be changed within the permitted boundaries. - Escape: Exits the basic menu. | |
| 2 | Standstill Rel.1 Out 1 Default 2.00 Hz | Enter standstill frequency | 100 mHz ... 10.0 Hz |
| 2 | v max Rel.2 Out 2 Default 500 Hz | Enter the max. permitted speed | 10 mHz ... 3.00 kHz |

Other, pre-defined settings:

- ▶ **Encoder type**
2 pnp type proximity switches
- ▶ **Parameter set/select input**
P0, select inputs are ignored (Select inputs mode: "None")
- ▶ **Hysteresis**
Standstill and speed, 2 % each
- ▶ **Output assignment**
 - Standstill: Relay output Rel.1 and semiconductor output Out 1
 - Speed: Relay output Rel.2 and semiconductor output Out 2

Safety relays PNOZsigma PNOZ s30

- ▶ **Start mode**
 - Rel.1 and semiconductor output Out 1, Rel.2 , Out 1, Out 2: Automatic start "Automatic"
- ▶ **Switch delay**
 - None
- ▶ **Max. encoder frequency**
 - 3.5 kHz

Basic settings for the rotary encoder

Settings for basic configuration 2

| Level | Designation on the display | Description | Settings |
|-------|---|---|--|
| 1 | Basic Parameter Encoder: Default Load? | Select the default settings with which the basic configuration menu " Rotary encoder: " is to be called: - Load: The basic parameters are loaded. Then it switches to the basic menu " Rotary encoder: ". The basic parameters should always be loaded when commissioning for the first time. - Edit: The basic parameters are not loaded, i.e. all parameters are retained. The basic menu parameters can be changed within the permitted boundaries. -Escape: Exits the basic menu. | |
| 2 | Encoder Default TTL differential | Select rotary encoder type | -TTL differential (A, /A, B, /B) -TTL single ended (A, B) -HTL differential (A, /A, B, /B) -HTL single ended (A, B) -sin/cos 1 Vss (A, /A, B, /B) -Hiperface (A, /A, B, /B) |
| 2 | Standstill Rel.1 Out 1 Default 100 Hz | Enter standstill frequency | 10 mHz to 1.00 kHz |

Safety relays PNOZsigma PNOZ s30

| Level | Designation on the display | Description | Settings |
|-------|---|--------------------------------|--------------------|
| 2 | v max Rel.2 Out 2 Default 5.00 kHz | Enter the max. permitted speed | 10 mHz to 1.00 MHz |

Other, pre-defined settings:

- ▶ **Switch functions**
 - **Direction (F3)**
Left direction
Tolerance for wrong direction = 10 pulses
 - **Direction (F4)**
Right direction
Tolerance for wrong direction = 10 pulses
- ▶ **Parameter set/select input**
P0, select inputs are ignored (Select inputs mode: "None ")
- ▶ **Hysteresis**
Standstill and speed, 2 % each
- ▶ **Output assignment**
 - Standstill: Relay output Rel. 1 and semiconductor output Out 1
 - Speed: Relay output Rel. 2 and semiconductor output Out 2
 - Left direction: External output Ext. 1 and semiconductor output Out 3
 - Right direction: External output Ext. 2 and semiconductor output Out 4
- ▶ **Start mode**
 - All outputs: Automatic start ("Automatic")
- ▶ **Switch delay**
None
- ▶ **Max. encoder frequency**
1 MHz

Safety relays PNOZsigma PNOZ s30

Settings

| Level | Designation on the display | Description | Settings |
|-------|---|---|---|
| 1 | Permanent Display Default H : Min : Sec (system time) v (current speed of track AB) Position | Permanent display Current values and information regarding configuration are displayed. You can change the permanent display on the display | Display combinations: -vz (current speed of track Z) -v (current speed of track AB) - Position - Switch functions F1...F9 - v (current speed of track AB) - Position - Line 1/2: F1/F2, F3/F2, F5/F4, F7/F6 or F9/F8 (parameters selected via select inputs). v (current speed of track AB) - H : Min : Sec (system time) - v (current speed of track AB) - Position |
| 1 | Displ. Units Speed: Dist: Default Hz Imp | Select unit of speed and distance (position). | Speed: (speed) - Pos. (distance/position) Hz Imp (pulse) Hz Edg (edge) m/s m m/min m m/h m rps rot rpm rot |
| 1 | Conversion Default 1 Hz= 1 Imp/s | Unit conversion. Enter ratio of unit to pulses. | Display 1 Hz= 1 Imp/s 1 Hz = 4 Edg/s 1 m = x Imp (x = 1 ... 10,000,000 pulses) 1 rot = x Imp (x = 1 ... 10,000,000 pulses) |

Safety relays PNOZsigma PNOZ s30

| Level | Designation on the display | Description | Settings |
|-------|--|---|---|
| 1 | Encoder Settings | Create encoder configuration for the tracks A, /A, B, /B, Z, /Z, S | |
| 2 | Encoder Default Undefined | Select pre-defined encoder types for the tracks A, B and Z: Proximity switch Encoder - with and without inverted signals - with or without Z-Index (0-Index) - with proximity switch at track Z Reference: If "Undefined" is selected, an error message is shown when you confirm the menu | <p>No encoder selected:</p> <ul style="list-style-type: none"> - Undefined <p>Proximity switch (Ini):</p> <ul style="list-style-type: none"> - Initiator A: pnp B: pnp - Initiator A: npn B: pnp - Initiator A: pnp B: npn - Initiator A: npn B: npn <p>Rotary encoder:</p> <p>TTL</p> <ul style="list-style-type: none"> - TTL differential (A, /A, B, /B) - TTL single ended (A, B) <p>TTL with Z-Index</p> <ul style="list-style-type: none"> -TTL diff. Z index (A, /A, B, /B, Z, /Z) - TTL single Z index (A, B, Z) <p>HTL</p> <ul style="list-style-type: none"> - HTL differential (A, /A, B, /B) - HTL single ended (A, B) <p>HTL with Z-Index</p> <ul style="list-style-type: none"> - HTL diff. Z index (A, /A, B, /B, Z, /Z) - HTL single Z index (A, B, Z) <p>Sin/Cos 1 Vss</p> <ul style="list-style-type: none"> - sin/cos 1 Vss (A, /A, B, /B) <p>Sin/Cos 1 Vss with Z-Index</p> <ul style="list-style-type: none"> - sin/cos 1 Vss Z Index (A, /A, B, /B, Z, /Z) <p>Hiperface</p> <ul style="list-style-type: none"> - Hiperface (A, /A, B, /B) |

Safety relays PNOZsigma PNOZ s30

| Level | Designation on the display | Description | Settings |
|-------|----------------------------|---|---|
| | | | <p>Rotary encoder + pnp proximity switch</p> <p>TTL + pnp proximity switch *</p> <ul style="list-style-type: none"> - TTL diff. (A, /A, B, /B), Z Freq Inipnp (Z) - TTL single (A, B), Z Freq Inipnp (Z) <p>HTL + pnp proximity switch *</p> <ul style="list-style-type: none"> - HTL diff. (A, /A, B, /B), Z Freq Inipnp (Z) - HTL single (A, B), Z Freq Inipnp (Z) <p>sin/cos 1 Vss + pnp proximity switch *</p> <ul style="list-style-type: none"> - sin/cos 1 Vss (A, /A, B, /B), Z Freq Inipnp (Z) <p>Hiperface + pnp proximity switch *</p> <ul style="list-style-type: none"> - Hiperface (A, /A, B, /B), Z Freq Inipnp (Z) <p>* Alternatively, a track from an HTL encoder can also be used instead of a pnp proximity switch</p> <p>The configuration is the same as with the pnp proximity switch as Z-frequency monitoring.</p> |
| 2 | Track /A/B | Settings for tracks A and B | |
| 3 | Type AB | For information only: Information on configured encoder type on tracks A and B | |

Safety relays PNOZsigma PNOZ s30

| Level | Designation on the display | Description | Settings |
|-------|---|--|------------------------|
| 3 | Track /A/B | For information only: Information on the use of the inverted tracks /A and /B: No track /A /B or Inverted (inverted tracks /A and /B used) or Uref external (e.g. "Hiperface" encoder type) | |
| 3 | AB Direction Default Normal | Select direction for tracks A and B Information: This function is used to display a forward movement as positive linear/rotational speed, irrespective of the installation of the rotary encoder. | - Normal - Inverted |
| 3 | Track AB fmax Default 10 mHz | Enter max. frequency of the encoder on tracks A and B Important: The frequency must be less than or equal to the max. encoder frequency specified in the encoder's data sheet and less than the max. speed of the monitored drive. | 10 mHz ... 1.00 MHz |
| 2 | Track Z | Settings for track Z | |
| 3 | Type Z | For information only: Information on configured encoder type at track Z | |
| 3 | Track /Z | For information only: Information on the use of the inverted track /Z: No track /Z or Inverted (inverted track /Z used) | |

Safety relays PNOZsigma PNOZ s30

| Level | Designation on the display | Description | Settings |
|-------|--|--|--------------------------------|
| 3 | Track Z fmax Default 10 mHz | Enter max. frequency of the encoder on track Z Important: The frequency must be less than the max. encoder frequency specified in the encoder's data sheet | 10 mHz ... 1.00 MHz |
| 2 | fAB/fZ Ratio Default 1.0000 : 1 | Enter the ratio of the frequency on tracks AB "fAB" to the frequency on track Z "fZ". Used to check the Z-Index or for frequency monitoring on track Z About Calculating the frequency ratio: Enter permanent display: "vz: v: Position:" Switch on drive Read vz and v Divide v/vz Enter result as ratio fAB to fZ | 0.0001 ... 400,000 : 1 |
| 2 | Track S | Settings for track S (error track) | |
| 3 | Track S Default Not used | Use of track S: -Not used (track S is not used) -Evaluation (track S is used) | - Not used - Evaluation |
| 3 | Track S Umax Default 6.0 V | Enter max. voltage at track S. If the voltage is > Umax, an error is displayed and the outputs are switched off. | 0.0 V ... 30.0 V |
| 3 | Track S Umin Default 2.0 V | Enter min. voltage at track S. If the voltage is < Umin, an error is displayed and the outputs are switched off. | 0.0 V ... 30.0 V |
| 1 | Delay Time Startup Default 0.00 s | Select start-up delay (The start-up phase of the PNOZ s30 is extended by this time. The encoder signals are not evaluated until after the start-up phase.) | 0 ... 600 s |

Safety relays PNOZsigma PNOZ s30

| Level | Designation on the display | Description | Settings |
|-------|---|--|--|
| 1 | Function Parameter | Select function parameter | |
| 2 | Standstill -v max: : Default 2.00 Hz | Select standstill frequency | 10 mHz ... 1.00 MHz or the corresponding value in the selected unit |
| 2 | (F1 ... F9) Parameter | Enter parameter for the switch functions F1 ... F9 | |
| 3 | (F1 ... F9) (P0 ... P15) Parameter Default 10 mHz | For each switch function F1 ... F9, 16 parameters P0 ... P15 can be configured. | |
| 4 | (F1 ... F9) (P0 ... P15) Teach v max: Display: Current linear/rotational speed | The current linear/rotational speed is displayed and can be adopted as a limit value. | |
| 4 | (F1 ... F9) (P0 ... P15) -v max: : Standstill | "Standstill" is displayed and can be adopted Info: The standstill frequency is selected globally in the menu " Standstill v max: " (see above) | |
| 4 | (F1 ... F9) (P0 ... P15) -v max: : 2.00 kHz | Select linear/rotational speed limit | 10 mHz ... 1.00 MHz or the corresponding value in the selected unit |
| 4 | (F1 ... F9) (P0 ... P15) Function Position (1 ... 4) | Select position monitoring 1 ... 4 | |

Safety relays PNOZsigma PNOZ s30

| Level | Designation on the display | Description | Settings |
|-------|--|--|--|
| 4 | (F1 ... F9) (P0 ... P15) (Direct. Left, Direct. Right) | Select left-hand or right-hand direction monitoring | |
| 1 | Assign Outputs | Assign functions to outputs | |
| 2 | Output (Rel.1 ... Out 4) Default Off | <p>Each output can be assigned a switch function (F1...F9) or a range (F2-F3, F4-F5, F6-F7, F8-F9). Each output can also be used as an error output (error) or be switched off (Off).</p> <p>When used as an error output, the following applies: Fault: Output off No error: Output on</p> <p>For ranges, the following applies: The lower range limit is the switch function with the lower number (e.g. F2), The upper range limit is the switch function with the higher number (e.g. F3).</p> <p>Outputs: Rel.1: Relay output 1 Rel.2: Relay output 2 Ext. 1: External output 1 Ext. 2: External output 2 Out 1 ... Out 4: Semiconductor outputs 1 ... 4</p> | -Off -F1...F9 -F2-F3 -F4-F5 -F6-F7 -F8-F9 -error |
| 1 | Start mode | Select start behaviour | |

Safety relays PNOZsigma PNOZ s30

| Level | Designation on the display | Description | Settings |
|-------|---|---|--|
| 2 | Start mode ((Rel.1 ... Out 4)) Default Monitored / | Select start mode for each output separately Automatic: Automatic start Monitored /: Monitored start with rising edge at S34 Monitored \: Monitored start with falling edge at S34 | - Automatic - Monitored / -Monitored \ |

Advanced settings

| Level | Menu designation | Description | Settings |
|-------|---|---|--|
| 1 | Positions Parameter | Settings for position monitoring functions | |
| 2 | Position (1 ... 4) Window width Default 1 pulse | Enter width of position window for position monitoring functions 1 ... 4 | 1 ... 24,900,000 pulses or the corresponding value in the selected unit |
| 1 | Direction Parameter | Settings for direction monitoring | |
| 2 | (Direct. Left max. right, Direct. Right max. left) Default 0 pulse | Enter max. tolerated number of pulses (or Edg, m, rot) in the wrong direction. | 1 ... 24,900,000 pulses or the corresponding value in the selected unit |
| 1 | Mode Select Input Default None | Setting for using the select inputs | -All 16 -1 from 4 -None |
| 1 | Delay Select Input Default tdl : 0 ms | Enter delay time of the select inputs Y10 – Y13 Info: The states of the select inputs are only adopted if they were unchanged during the set time. | 0 ... 30.0 s |
| 1 | Function Hysteresis | | |

Safety relays PNOZsigma PNOZ s30

| Level | Menu designation | Description | Settings |
|-------|--|---|--------------------------------|
| 2 | (F1 ... F9) Function Hysteresis Default 1 % | Enter hysteresis for the switching functions F1 ... F9 (not effective with position and direction monitoring) | 0 ... 50 % |
| 1 | Output Delay | Setting for the delay effect and delay time for the outputs | |
| 2 | Delay Output (Rel.1 ... Out 4) Default On 0 ms (display only) | Setting for the delay time effect and delay time for the respective output | |
| 3 | Delay Effect (Rel.1 ... Out 4) Default On delay | Enter whether the delay time is to be activated when switching on, switching off, or switching on and off. | - On - Off -OnOff |
| 3 | Delay Time (Rel.1 ... Out 4) Default tdO: 0 ms | Select delay time for the respective output | 0 ... 30.0 s |
| 1 | Output Out Logic | Setting for the switching direction of the semiconductor outputs | |
| 2 | output (Out 1 ... Out 4) Logic Default N/O contact | Select the switching direction of the semiconductor outputs Out 1 ... Out 4: N/O contact (normally energised mode) N/C contact (normally de-energised mode) | - N/O contact - N/C contact |
| 1 | Name of Configuration Default Default | Enter name of the configuration The name may be a max. of 8 characters in length It is stored on the chip card | |

Safety relays PNOZsigma PNOZ s30

| Level | Menu designation | Description | Settings |
|-------|---------------------------------------|---|----------------------------------|
| 1 | Password Settings | Change passwords Reference: In the "Default Settings" menu, the passwords are reset to the default setting: 00000. | |
| 2 | Master PW | Change master password | 0000 ... 9999 |
| 2 | Customer PW | Change customer password | 0000 ... 9999 |
| 2 | Language Default English | Select menu language | -English - German - French |
| 1 | Default Settings | Select whether the parameters are to be reset to the default settings Yes: All parameters are reset to the default values. The language is set to English and all passwords are set to 0000. | - Escape - Yes |

Safety relays PNOZsigma PNOZ s30

Information

| Level | Menu designation | Description | Display/Settings |
|-------|--------------------------------------|--|---|
| 1 | System Time | Time that the device is switched on | xxx.xxx h xx min xx s |
| 1 | Max. Speed Track AB | Max. measured linear/rotational speed at tracks A and B The value can be reset to 0 | 0 ... 4.29 MHz or the corresponding value in the set unit Reset: Reset: - Yes ? - No |
| 1 | Max. Speed Track Z | Max. measured linear/rotational speed at track Z The value can be reset to 0 | 0 ... 4.29 MHz or the corresponding value in the set unit Reset: Reset: - Yes? - No? |
| 1 | Relay (Ctrl, 1, 2) Cycles | Information: Total number of relay operations Relay Ctrl (Root relay, common 2nd shutdown route) Relay 1 (Relay output 1: 11-12, 13-14) Relay 2 (Relay output 2: 21-22, 23-24) | 0 ... 6,000,000 x, > 6,000,000 x |
| 1 | CRC of Configuration | Check sum of configuration parameters | 0 ... 65535 |

Safety relays PNOZsigma PNOZ s30

| Level | Menu designation | Description | Display/Settings |
|-------|--|--|--|
| 1 | Error Stack Entries | <p>Error stack entries</p> <p>Up to 20 error stack entries are displayed</p> <p>Repairable errors: Level 2, 3 and 4 (can be rectified by user)</p> <p>System errors: Level 2 and 3 (internal error, information for Pilz Service).</p> | <p>Repairable error:</p> <p>Level 2:</p> <p>1st line: Seq. No. "Err.:", error number</p> <p>2nd + 3rd line: Plain text to describe error for the user</p> <p>Level 3:</p> <p>1st line: Seq. No. "Repairable"</p> <p>2nd line: "System time"</p> <p>3rd line: System time when the error occurred</p> <p>Level 4:</p> <p>Information for Pilz Service</p> <p>System errors:</p> <p>Level 2:</p> <p>1st line: Seq. No. "Err.:", error number</p> <p>2nd line: "System Error"</p> <p>3rd line: System time when the error occurred</p> <p>Level 3:</p> <p>Information for Pilz Service</p> |
| 1 | Input Module SW Version Va.b | For internal purposes only | |
| 1 | Main Unit SW Version Va.b | For internal purposes only | |

Safety relays PNOZsigma PNOZ s30

| Level | Menu designation | Description | Display/Settings |
|-------|---|---|--|
| - | Actual Errors | <p>Up to 8 errors are displayed.</p> <p>Repairable errors: Level 2, 3 and 4 (can be rectified by user)</p> <p>System errors: Level 2 and 3 (internal error, information for Pilz Service).</p> <p>The error messages can be hidden with "Escape".</p> | <p>Repairable error:</p> <p>Level 2:</p> <p>1st line: Seq. No. "Err.:", error number</p> <p>2nd + 3rd line: Plain text to describe error for the user</p> <p>Level 3:</p> <p>1st line: Seq. No. "Repairable"</p> <p>2nd line: "System time"</p> <p>3rd line: System time when the error occurred</p> <p>Level 4:</p> <p>Information for Pilz Service</p> <p>System errors:</p> <p>Level 2:</p> <p>1st line: Seq. No. "Err.:", error number</p> <p>2nd line: "System Error"</p> <p>3rd line: System time when the error occurred</p> <p>Level 3:</p> <p>Information for Pilz Service</p> |
| - | Error Faulty Signal: A/A B/B Z/Z | <p>Error message: Incorrect signal at one or more tracks.</p> <p>The message</p> <ul style="list-style-type: none"> - is continually updated. - can be ignored temporarily. | |
| - | AB frequency deviation | <p>Error message: Frequency difference between the proximity switches on tracks A and B</p> <p>The message</p> <ul style="list-style-type: none"> - is continually updated - can be ignored temporarily | |
| - | Chip card messages | | |

Safety relays PNOZsigma PNOZ s30

| Level | Menu designation | Description | Display/Settings |
|-------|---|--|------------------|
| - | Please insert SIM Card! | Appears when the device is operated without a chip card or when a defective chip card is inserted, appears again when parameters are changed. Info: The message disappears after 30 s or by pressing the rotary knob | |
| - | Please insert writable SIM Card! | Appears when the answer to " Load SIM " and " Write Configuration to SIM: " is "No" | |
| - | SIM: CRC: Load SIM Default No? | Appears when device detects a chip card with a valid configuration. -> Select whether the data on the chip card is to be transferred to the device. | - No? - Yes? |
| - | Write Configuration to SIM: Default No? | Appears - When a chip card has been used that does not yet contain data - When a chip card has been used that does not contain any valid data - When Load SIM No was selected -> Select whether the data on the chip card is to be saved. | - No? - Yes? |
| - | Password messages | | |
| - | Master PW Default 0000 | -> Enter master password Password: | 0000 ... 9999 |

Safety relays PNOZsigma PNOZ s30

| Level | Menu designation | Description | Display/Settings |
|-------|-------------------------------------|----------------------------|------------------|
| - | Password: Default 0000 | -> Enter customer password | 0000 ... 9999 |

Safety relays PNOZsigma PNOZ s30

Example: Configure basic configuration 2

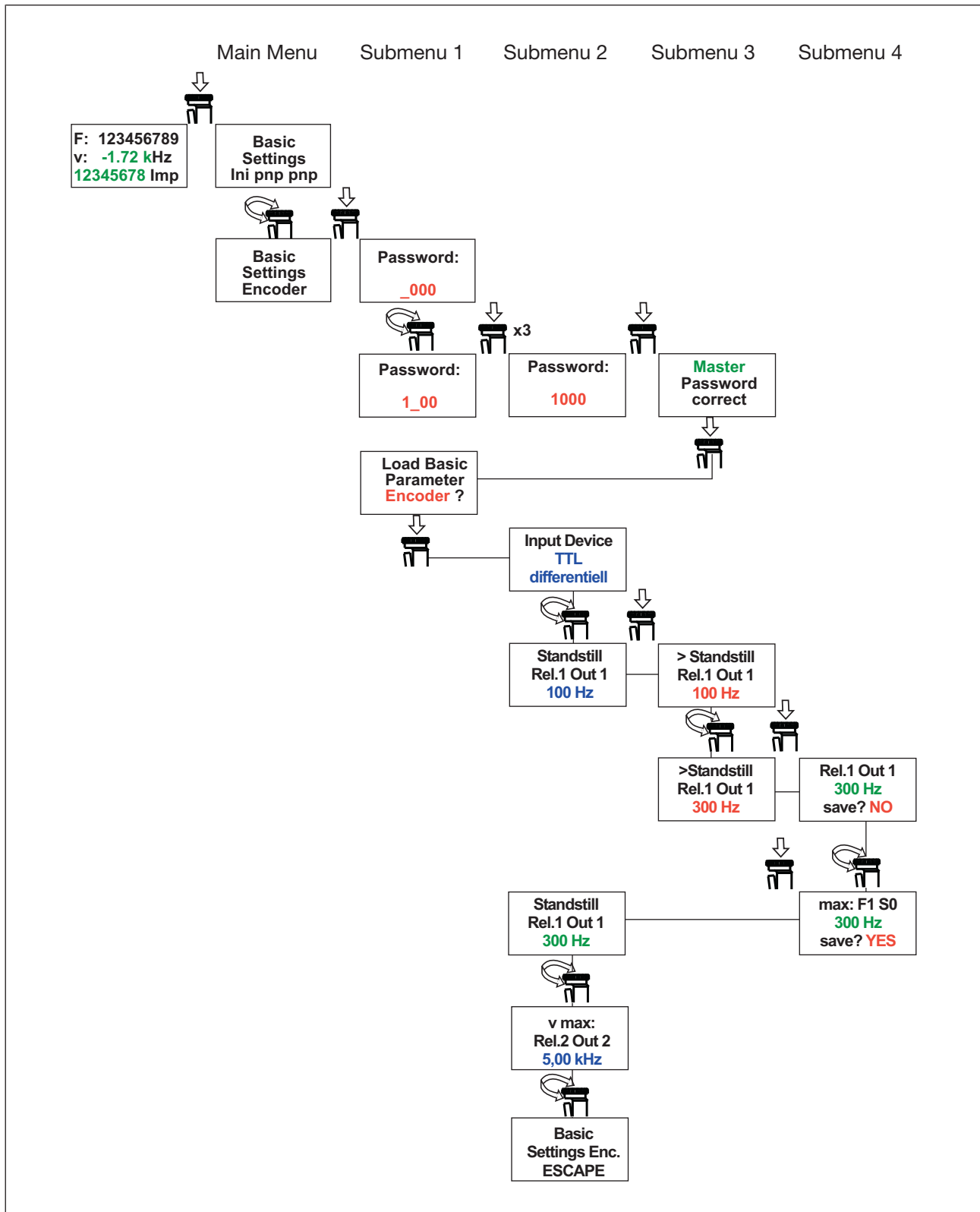

Safety relays PNOZsigma PNOZ s30

Technical details

| General | 750330 | 751330 |
|--|----------------------------------|----------------------------------|
| Approvals | CCC, CE, GOST, TÜV, cULus Listed | CCC, CE, GOST, TÜV, cULus Listed |
| Electrical data | 750330 | 751330 |
| Supply voltage | | |
| Voltage | 24 - 240 V | 24 - 240 V |
| Kind | AC/DC | AC/DC |
| Voltage tolerance | -15 %/+10 % | -15 %/+10 % |
| Output of external power supply (AC) | 9,0 VA | 9,0 VA |
| Output of external power supply (DC) | 5,5 W | 5,5 W |
| Frequency range AC | 50 - 60 Hz | 50 - 60 Hz |
| Residual ripple DC | 160 % | 160 % |
| Duty cycle | 100 % | 100 % |
| External unit fuse protection F1 min. | 1,00 A | 1,00 A |
| External unit fuse protection F1 max. | Max. conductor cross section | Max. conductor cross section |
| Proximity switch input | 750330 | 751330 |
| Number of inputs | 2 | 2 |
| Input signal level | | |
| Signal level at "1" | 11 - 30 V | 11 - 30 V |
| Signal level at "0" | -3 - 5 V | -3 - 5 V |
| Input resistance | 22 kOhm | 22 kOhm |
| Input's frequency range | 0 - 1.000 kHz | 0 - 1.000 kHz |
| Configurable monitoring frequency | | |
| Without hysteresis | 10 mHz - 1.000 kHz | 10 mHz - 1.000 kHz |
| Incremental encoder input | 750330 | 751330 |
| Number of inputs | 1 | 1 |
| Connection type | RJ45 female connector, 8-pin | RJ45 female connector, 8-pin |
| Input signal level | 0,5 - 30,0 Vss | 0,5 - 30,0 Vss |
| Phase position for the differential signals A, /A and B,/B | 90° ±30° | 90° ±30° |
| Overload protection | -50 - 65 V | -50 - 65 V |
| Input resistance | 20,0 kOhm | 20,0 kOhm |
| Input's frequency range | 0 - 1.000 kHz | 0 - 1.000 kHz |
| Configurable monitoring frequency | | |
| Without hysteresis | 10 mHz - 1.000 kHz | 10 mHz - 1.000 kHz |

Safety relays PNOZsigma PNOZ s30

| Inputs | 750330 | 751330 |
|---|---------------------|---------------------|
| Voltage at | | |
| Start circuit DC | 24,0 V | 24,0 V |
| Feedback loop DC | 24,0 V | 24,0 V |
| Current at | | |
| Start circuit DC | 5,0 mA | 5,0 mA |
| Feedback loop DC | 5,0 mA | 5,0 mA |
| Max. inrush current impulse | | |
| Current pulse, feedback loop | 0,06 A | 0,06 A |
| Current pulse, start circuit | 0,06 A | 0,06 A |
| Semiconductor outputs | 750330 | 751330 |
| Number | 4 | 4 |
| Voltage | 24,0 V | 24,0 V |
| Current | 50 mA | 50 mA |
| External supply voltage | 24,0 V | 24,0 V |
| Voltage tolerance | -20% / +20% | -20% / +20% |
| Relay outputs | 750330 | 751330 |
| Number of output contacts | | |
| Safety contacts (N/O), instantaneous | 2 | 2 |
| Auxiliary contacts (N/C) | 2 | 2 |
| Utilisation category | | |
| In accordance with the standard | EN 60947-4-1 | EN 60947-4-1 |
| Utilisation category of safety contacts | | |
| AC1 at | 240 V | 240 V |
| Min. current | 0,01 A | 0,01 A |
| Max. current | 4,0 A | 4,0 A |
| Max. power | 1000 VA | 1000 VA |
| DC1 at | 24 V | 24 V |
| Min. current | 0,01 A | 0,01 A |
| Max. current | 4,0 A | 4,0 A |
| Max. power | 100 W | 100 W |

Safety relays PNOZsigma PNOZ s30

| Relay outputs | 750330 | 751330 |
|--|--------------------|--------------------|
| Utilisation category of auxiliary contacts | | |
| AC1 at | 240 V | 240 V |
| Min. current | 0,01 A | 0,01 A |
| Max. current | 4,0 A | 4,0 A |
| Max. power | 1000 VA | 1000 VA |
| DC1 at | 24 V | 24 V |
| Min. current | 0,01 A | 0,01 A |
| Max. current | 4,0 A | 4,0 A |
| Max. power | 100 W | 100 W |
| Utilisation category | | |
| In accordance with the standard | EN 60947-5-1 | EN 60947-5-1 |
| Utilisation category of safety contacts | | |
| AC15 at | 230 V | 230 V |
| Max. current | 3,0 A | 3,0 A |
| DC13 (6 cycles/min) at | 24 V | 24 V |
| Max. current | 4,0 A | 4,0 A |
| Utilisation category of auxiliary contacts | | |
| AC15 at | 230 V | 230 V |
| Max. current | 3,0 A | 3,0 A |
| DC13 (6 cycles/min) at | 24 V | 24 V |
| Max. current | 4,0 A | 4,0 A |
| External contact fuse protection, safety contacts | | |
| In accordance with the standard | EN 60947-5-1 | EN 60947-5-1 |
| Blow-out fuse, quick | 6 A | 6 A |
| Blow-out fuse, slow | 4 A | 4 A |
| Circuit breaker 24V AC/DC, characteristic B/C | 4 A | 4 A |
| External contact fuse protection, auxiliary contacts | | |
| Blow-out fuse, quick | 6 A | 6 A |
| Blow-out fuse, slow | 4 A | 4 A |
| Circuit breaker 24 V AC/DC, characteristic B/C | 4 A | 4 A |
| Conventional thermal current | 4,0 A | 4,0 A |
| Contact material | AgCuNi + 0,2 µm Au | AgCuNi + 0,2 µm Au |

Safety relays PNOZsigma PNOZ s30

| Times | 750330 | 751330 |
|--|-----------------|-----------------|
| Switch-on delay | | |
| With automatic start typ. | 15 ms | 15 ms |
| With automatic start max. | 50 ms | 50 ms |
| With automatic start after power on typ. | 3.920 ms | 3.920 ms |
| With automatic start after power on max. | 4 s | 4 s |
| With manual start typ. | 40 ms | 40 ms |
| With manual start max. | 100 ms | 100 ms |
| Delay-on de-energisation | | |
| With power failure typ. UB 240 V | 100 ms | 100 ms |
| With power failure max. UB 240 V | 150 ms | 150 ms |
| After safety function is triggered typ. | 8 ms | 8 ms |
| After safety function is triggered max. | 15 ms | 15 ms |
| Recovery time at max. switching frequency 1/s | | |
| After power failure | 4 s | 4 s |
| After safety function is triggered | 1 s | 1 s |
| Reaction time after limit value is exceeded | 1/f_ist + 16 ms | 1/f_ist + 16 ms |
| Waiting period with a monitored start | | |
| With rising edge | 30 ms | 30 ms |
| With falling edge | 30 ms | 30 ms |
| Min. start pulse duration with a monitored start | | |
| With rising edge | 30 ms | 30 ms |
| With falling edge | 30 ms | 30 ms |
| Supply interruption before de-energisation | 20 ms | 20 ms |
| Switch delay (selectable) | 0 - 30 s | 0 - 30 s |
| Delay on the select inputs (selectable) | 0 - 30 s | 0 - 30 s |
| Start-up delay (selectable) | 0 - 600 s | 0 - 600 s |
| Environmental data | 750330 | 751330 |
| Climatic suitability | EN 60068-2-78 | EN 60068-2-78 |
| Ambient temperature | | |
| Temperature range | -20 - 55 °C | -20 - 55 °C |
| Storage temperature | | |
| Temperature range | -40 - 85 °C | -40 - 85 °C |

Safety relays PNOZsigma PNOZ s30

| Environmental data | 750330 | 751330 |
|---|---|---|
| EMC | EN 60947-5-1, EN 61000-6-2, EN 61000-6-3 | EN 60947-5-1, EN 61000-6-2, EN 61000-6-3 |
| Vibration | | |
| In accordance with the standard | EN 60068-2-6 | EN 60068-2-6 |
| Frequency | 10,0 - 55,0 Hz | 10,0 - 55,0 Hz |
| Amplitude | 0,35 mm | 0,35 mm |
| Airgap creepage | | |
| In accordance with the standard | EN 60947-1 | EN 60947-1 |
| Overvoltage category | II | II |
| Pollution degree | 2 | 2 |
| Rated insulation voltage | 250 V | 250 V |
| Rated impulse withstand voltage | 4,00 kV | 4,00 kV |
| Protection type | | |
| Mounting area (e.g. control cabinet) | IP54 | IP54 |
| Housing | IP30 | IP30 |
| Terminals | IP20 | IP20 |
| Mechanical data | 750330 | 751330 |
| Mounting position | Horizontal on top hat rail | Horizontal on top hat rail |
| Mechanical life | 10,000,000 cycles | 10,000,000 cycles |
| Material | | |
| Bottom | PC | PC |
| Front | PC | PC |
| Top | PC | PC |
| Connection type | Screw terminal | Spring-loaded terminal |
| Mounting type | plug-in | plug-in |
| Conductor cross section with screw terminals | | |
| 1 core flexible | 0,25 - 2,50 mm ² , 24 - 12 AWG | – |
| 2 core with the same cross section, flexible with crimp connectors, no plastic sleeve | 0,25 - 1,00 mm ² , 24 - 16 AWG | – |
| 2 core with the same cross section, flexible without crimp connectors or with TWIN crimp connectors | 0,20 - 1,50 mm ² , 24 - 16 AWG | – |
| Torque setting with screw terminals | 0,50 Nm | – |
| Conductor cross section with spring-loaded terminals: Flexible with/without crimp connector | – | 0,20 - 2,50 mm ² , 24 - 12 AWG |
| Spring-loaded terminals: Terminal points per connection | – | 2 |

Safety relays PNOZsigma PNOZ s30

| Mechanical data | 750330 | 751330 |
|---|----------|----------|
| Stripping length with spring-loaded terminals | – | 9 mm |
| Dimensions | | |
| Height | 98,0 mm | 100,0 mm |
| Width | 45,0 mm | 45,0 mm |
| Depth | 120,0 mm | 120,0 mm |
| Weight | 410 g | 410 g |

Where standards are undated, the 2009-06 latest editions shall apply.

Safety characteristic data

| Operating Mode | EN ISO 13849-1: 2015 PL | EN ISO 13849-1: 2015 Category | EN 62061 SIL CL | EN 62061 PFH _D [1/h] | IEC 61511 SIL | IEC 61511 PFD | EN ISO 13849-1: 2015 T _M [year] |
|-------------------------|----------------------------|----------------------------------|--------------------|------------------------------------|------------------|------------------|---|
| Monitoring 1 encoder | PL d | Cat. 2 | SIL CL 2 | 2,34E-08 | SIL 2 | 2,05E-03 | 20 |
| Monitoring 2 encoder | PL e | Cat. 4 | SIL CL 3 | 1,44E-09 | SIL 3 | 1,21E-04 | 20 |
| Monitoring safe encoder | PL e | Cat. 4 | SIL CL 3 | 2,78E-09 | SIL 3 | 2,40E-04 | 20 |

All the units used within a safety function must be considered when calculating the safety characteristic data.

The PFH value depends on the switching frequency and the load on the relay output. If the service life graphs are not accessible, the stated PFH value can be used irrespective of the switching frequency and the load, as the PFH value already considers the relay's B10d value as well as the failure rates of the other components.

Safety relays PNOZsigma PNOZ s30

Supplementary data

Service life graph of output relays

The service life graphs indicate the number of cycles from which failures due to wear must be expected. The wear is mainly caused by the electrical load; the mechanical load is negligible.

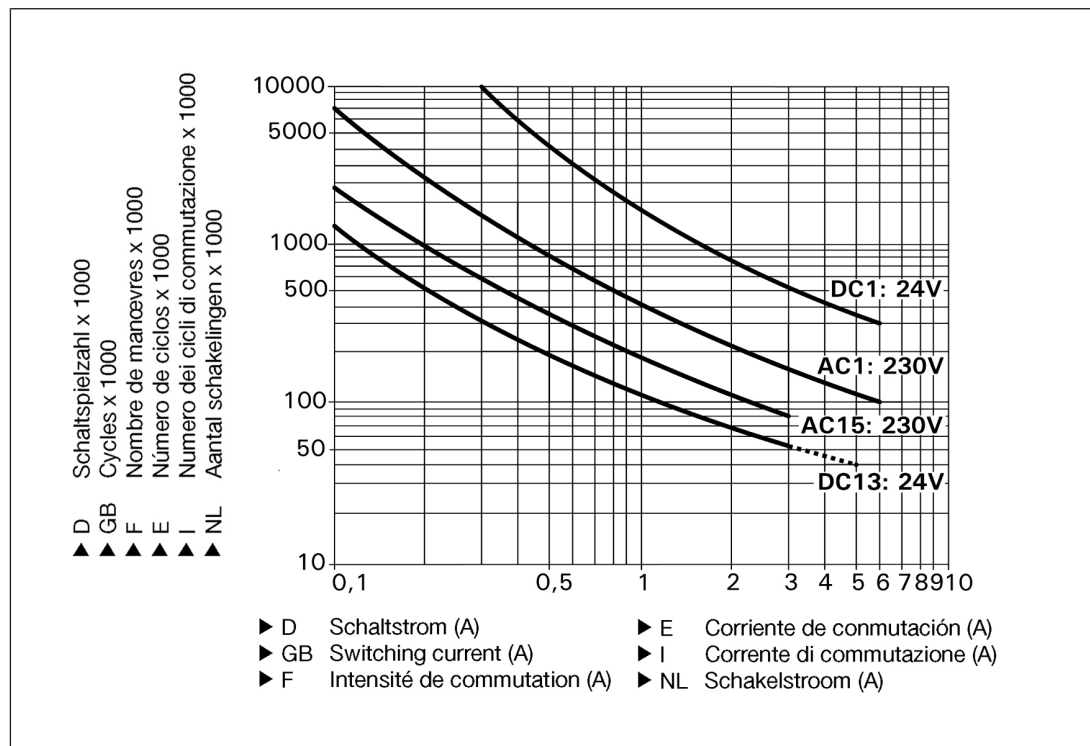

Example

- ▶ Inductive load: 0.2 A
- ▶ Utilisation category: AC15
- ▶ Contact service life: 1 000 000 cycles

Provided the application to be implemented requires fewer than 1 000 000 cycles, the PFH value (see [Technical details \[868\]](#)) can be used in the calculation.

To increase the service life, sufficient spark suppression must be provided on all relay contacts. With capacitive loads, any power surges that occur must be noted. With DC contactors, use flywheel diodes for spark suppression.

Safety relays PNOZsigma PNOZ s30

Categories

Safety level

The maximum achievable safety level depends on the encoder, the wiring and the operating mode of the PNOZ s30.

Information on the safety-related characteristic data for the subsystems *Sensor* and *PNOZ s30*

Example:

| Sensor subsystem | | | PNOZ s30 subsystem | |
|------------------|-----------------------|------|-------------------------|-----------|
| Category | MTTFd | DC | Operating mode | PFH [1/h] |
| 2 | Manufacturer-specific | 90 % | Monitoring 1 encoder | 3,28E-08 |

The values for *Category* and *DC* can be set for the sensor subsystem, bearing in mind the restrictions stated in the respective chapter. The MTTFd value must be stated by the device manufacturer.

Assuming that all faults are dangerous, $MTTF = MTTFd$ can be set.

The characteristic value MTTF is a property of the sensor, which may only be stated by the manufacturer.

Forced dynamisation:

When monitoring sensors with square output signals (TTL, HTL) or safe sensors, the axis must be moved within 8 hours so that the signal changes on all the connected tracks.

Key:

SRP/CS = Safety-related part of a control system (EN 13849-1, Tab. 2)

Safety functions

The following safe monitoring functions are available:

- ▶ Standstill
- ▶ Position
- ▶ Speed
- ▶ Speed range
- ▶ Direction
- ▶ Monitoring for broken shearpins

The safety functions of the PNOZ s30 are monitoring functions, whereby a safe output signal is used to show if defined limit values are exceeded.

The reaction function that takes place (e.g. shutting down the drive, activating a mechanical brake) when exceeded limit values are detected during the normal operation of the safety function must be defined and implemented by the machine/plant developer and does not form part of the PNOZ s30.

Safety relays PNOZsigma PNOZ s30

The monitoring function of the PNOZ s30 can be used to implement safety functions defined in the standard EN 61800-5-2 for Adjustable speed electrical power drive systems.

| Safety functions in accordance with EN 61800-5-2 | Implementation with PNOZ s30 safety function |
|--|--|
| Safe Operating Stop (SOS) | Standstill, position |
| Safely Limited Speed (SLS) | Speed |
| Safe Speed Range (SSR) | Speed range |
| Safe Direction (SDI) | Direction |
| Safe Speed Monitor (SSM) | Speed, speed range |

Safety-related characteristic data for operation with non-safety-related rotary encoder without additional requirements

Permitted encoder types and output signals

Permitted encoder types:

- ▶ Rotary non-safety-related encoders
- ▶ Linear non-safety-related encoders

Permitted output signals:

- ▶ Square output signals TTL, single ended
- ▶ Square output signals TTL, differential
- ▶ Square output signals HTL, single ended
- ▶ Square output signals HTL, differential
- ▶ Sin/Cos output signals 1Vss, reference voltage
- ▶ Sin/Cos output signals 1Vss, differential

Safety-related architecture

To calculate the safety function you will need the following data for the "sensor" subsystem and "PNOZ s30" subsystem:

| Sensor | | | PNOZ s30 subsystem | |
|----------|-----------------------|-----|-------------------------|-----------|
| Category | MTTFd | DC | Operating mode | PFH (1/h) |
| 1* | Manufacturer-specific | 0 % | Monitoring 1 encoder | 2,34-08 |

*In accordance with EN ISO 13849-1, Category 1 is only met if the sensor is a "well-tried component".

Safety relays PNOZsigma PNOZ s30

Achievable safety level

| Safety function | PL in accordance with EN ISO 13849-1: 2015 | SIL CL in accordance with EN IEC 62061 |
|---|--|--|
| Speed Speed range Direction Standstill Position | PL c (Cat. 1) | - |

Safety-related characteristic data for operation with non-safety-related rotary encoder with mechanical fault exclusion

In accordance with EN 61800-5-2 : 2007, Table D.16 (Motion and position feedback sensors), fault exclusions are permitted for faults in the mechanical connection between the sensor (encoder) and motor.

Permitted encoder types and output signals

Permitted encoder types:

- ▶ Rotary non-safety-related encoders

Permitted output signals:

- ▶ Sin/Cos output signals 1V_{ss}, reference voltage
- ▶ Sin/Cos output signals 1V_{ss}, differential

Safety-related architecture

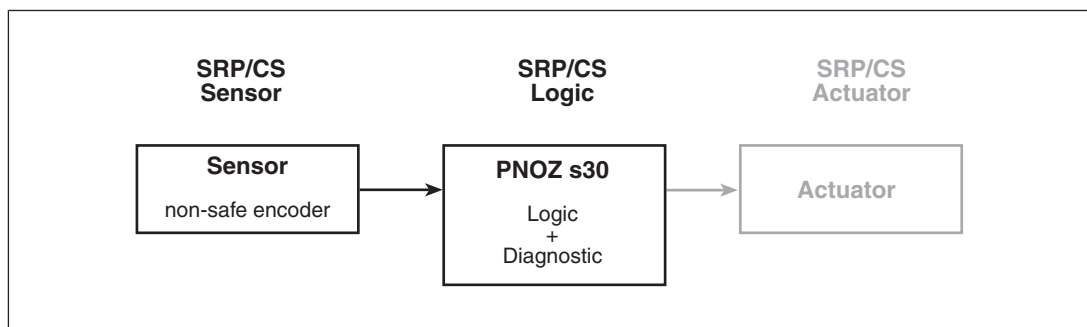

To calculate the safety function you will need the following data for the "sensor" subsystem and "PNOZ s30" subsystem:

| Sensor | | | PNOZ s30 subsystem | |
|----------|-----------------------|------|-------------------------|-----------|
| Category | MTTFd | DC | Operating mode | PFH (1/h) |
| 2 | Manufacturer-specific | 90 % | Monitoring 1 encoder | 2,34E-08 |

Safety relays PNOZsigma PNOZ s30

Achievable safety level

| Safety function | PL in accordance with EN ISO 13849-1: 2015 | SIL CL in accordance with EN IEC 62061 |
|-----------------|--|--|
| Speed | PL d (Cat. 2) | 2 |
| Speed range | | |
| Direction | | |
| Standstill | | |
| Position | | |

Safety-related characteristic data for operation with non-safety-related rotary encoder with diagnostics via the drive controller

The detection of encoder errors (diagnostics for the sensor subsystem via the evaluation device) can be supplemented with a drive controller.

Permitted encoder types and output signals

Permitted encoder types:

- ▶ Rotary non-safety-related encoders
- ▶ Linear non-safety-related encoders

Permitted output signals:

- ▶ Square output signals TTL, single ended
- ▶ Square output signals TTL, differential
- ▶ Square output signals HTL, single ended
- ▶ Square output signals HTL, differential
- ▶ Sin/Cos output signals 1V_{ss}, reference voltage
- ▶ Sin/Cos output signals 1V_{ss}, differential

Requirements of the drive controller

- ▶ Parameters for the control loops and motor control must be set in such a way as to guarantee stable operation.
Drag error detection (see below) must be capable of operating in accordance with the requirements of the safety function.
- ▶ The motor must be operated with a current impressing control procedure, based on the rotor position (field-oriented control). If the analogue track signals are idle, field-oriented control will brake and/or stop the rotor.
- ▶ The drive controller must be in position control operating mode.
- ▶ If a maximum error variable is exceeded (set/true comparison) the drive controller must switch to a fault condition and stop the drive (drag error detection). The error reaction to drag error detection should be a controlled motor stop.

Safety relays PNOZsigma PNOZ s30

- ▶ Fault detection via the error variable with subsequent shutdown must meet the requirements of the safety function, with regard to reaction times for example.
- ▶ The drive controller must evaluate the same incremental/sincos signals from the encoder for control as are processed by the safe evaluation device (important on encoders with combined analogue/digital interface).

Safety-related architecture

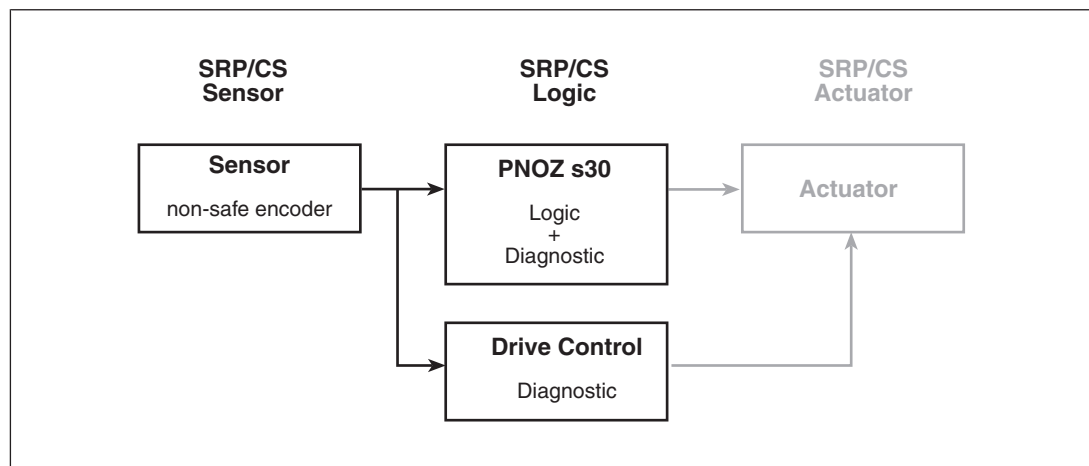

To calculate the safety function you will need the following data for the "sensor" subsystem and "PNOZ s30" subsystem:

| Sensor | | | PNOZ s30 subsystem | |
|----------|-----------------------|------|-------------------------|-----------|
| Category | MTTFd | DC | Operating mode | PFH (1/h) |
| 2 | Manufacturer-specific | 90 % | Monitoring 1 encoder | 2,34E-08 |

Achievable safety level

| Safety function | PL in accordance with EN ISO 13849-1: 2015 | SIL CL in accordance with EN IEC 62061 |
|-----------------|--|--|
| Speed | PL d (Cat. 2) | 2 |
| Speed range | | |
| Direction | | |
| Standstill | | |
| Position | | |

Safety relays PNOZsigma PNOZ s30

Safety-related characteristic data for operation with a safe rotary encoder

Safe encoders are certified in accordance with EN 61508, EN 13849 and EN 62061. In order to achieve the safety level stated by the encoder, the safe evaluation device (PNOZ s30) must normally detect designated errors. Details of the safe encoder's requirements of the evaluation device can be found in the user documentation for the safe encoder. The encoder and evaluation device must be compatible.

Permitted encoder types and output signals

Permitted encoder types:

- ▶ Rotary safe encoder
- ▶ Linear safe encoder

Permitted output signals:

- ▶ Sin/Cos output signals 1Vss, reference voltage
- ▶ Sin/Cos output signals 1Vss, differential

Safety-related architecture

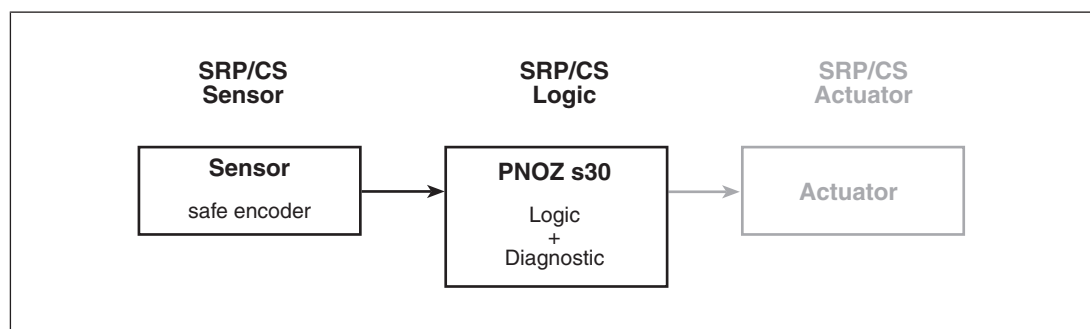

To calculate the safety function you will need the following data for the "sensor" subsystem and "PNOZ s30" subsystem:

| Sensor | | | PNOZ s30 subsystem | |
|------------------|-----|-----------|----------------------------|-----------|
| PL | SIL | PFH (1/h) | Operating mode | PFH (1/h) |
| See manufacturer | | | Monitoring Safe encoder | 2,78E-09 |

Safety relays PNOZsigma PNOZ s30

Achievable safety level

| Safety function | PL in accordance with EN ISO 13849-1: 2015 | SIL CL in accordance with EN IEC 62061 |
|-----------------|--|--|
| Speed | PL e (Cat.4) | 3 |
| Speed range | | |
| Direction | | |
| Standstill | | |
| Position | | |

Safety-related characteristic data for operation with a safe rotary encoder with Z index

Safe encoders are certified in accordance with EN 61508, EN 13849 and EN 62061. In order to achieve the safety level stated by the encoder, the safe evaluation device (PNOZ s30) must normally detect designated errors. Details of the safe encoder's requirements of the evaluation device can be found in the user documentation for the safe encoder. The encoder and evaluation device must be compatible.

Permitted encoder types and output signals

Permitted encoder types:

- ▶ Rotary safe encoder
- ▶ Linear safe encoder

Permitted output signals:

- ▶ Square output signals TTL, differential with Z index
- ▶ Square output signals HTL, differential with Z index
- ▶ Sin/Cos output signals 1Vss, reference voltage with Z index
- ▶ Sin/Cos output signals 1Vss, differential with Z index

Safety relays PNOZsigma PNOZ s30

Safety-related architecture

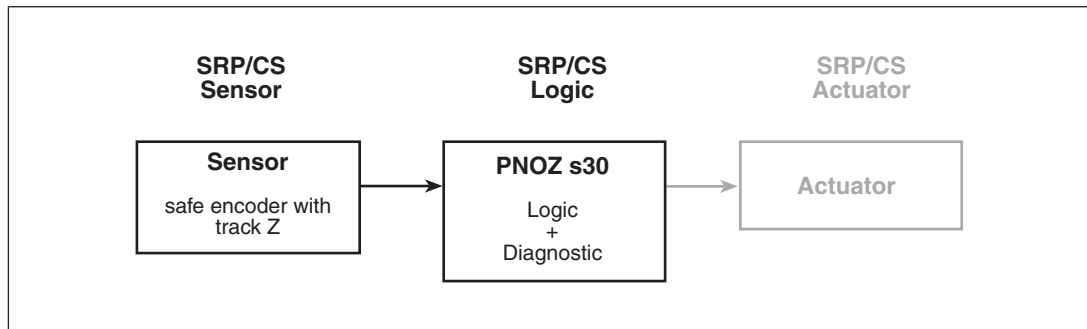

To calculate the safety function you will need the following data for the "sensor" subsystem and "PNOZ s30" subsystem:

| Sensor | | | PNOZ s30 subsystem | |
|------------------|-----|-----------|--------------------------|-----------|
| PL | SIL | PFH (1/h) | Operating mode | PFH (1/h) |
| See manufacturer | | | Monitoring 2 encoders | 1,44E-09 |

Achievable safety level

| Safety function | PL in accordance with EN ISO 13849-1: 2015 | SIL CL in accordance with EN IEC 62061 |
|---|--|--|
| Speed Speed range Direction Standstill Position | PL e (Cat.4) | 3 |

Safety-related characteristic data for operation with non-safety-related rotary encoder and proximity switch

The speed monitoring of the non-safety-related encoder can be verified via an additional reference sensor.

Permitted encoder types and output signals

Non-safety-related rotary encoder

Permitted encoder types:

- ▶ Rotary non-safety-related encoders
- ▶ Linear non-safety-related encoders

Safety relays PNOZsigma PNOZ s30

Permitted output signals:

- ▶ Square output signals TTL, single ended
- ▶ Square output signals TTL, differential
- ▶ Square output signals HTL, single ended
- ▶ Square output signals HTL, differential
- ▶ Sin/Cos output signals 1Vss, reference voltage
- ▶ Sin/Cos output signals 1Vss, differential

Reference sensor

Permitted encoder types:

- ▶ Rotary non-safety-related encoders
- ▶ Linear non-safety-related encoders
- ▶ Inductive proximity switches

Permitted output signals:

- ▶ Square output signals HTL, single ended
- ▶ Square output signal 24 V, pnp

Safety-related architecture

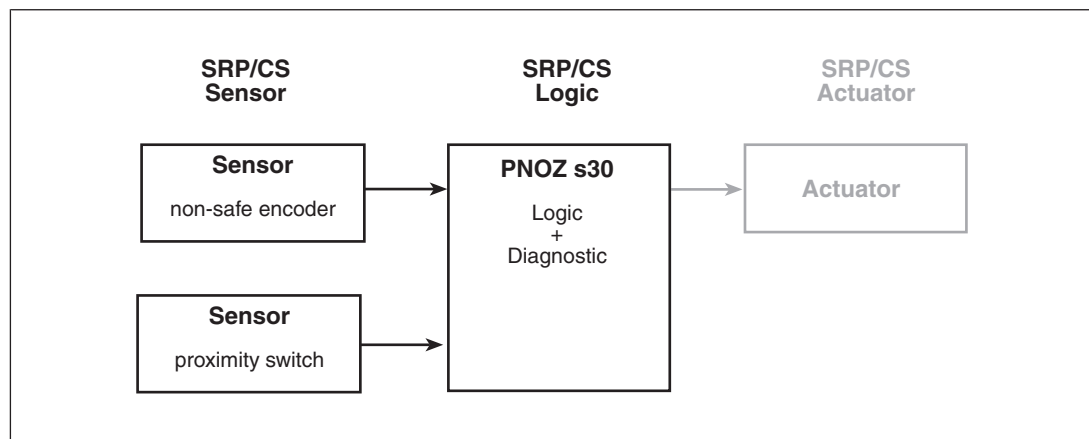

To calculate the safety function you will need the following data for the "sensor" subsystem and "PNOZ s30" subsystem:

| Sensor | | | PNOZ s30 subsystem | |
|----------|-----------------------|------|--------------------------|-----------|
| Category | MTTFd | DC | Operating mode | PFH (1/h) |
| 4 | Manufacturer-specific | 90 % | Monitoring 2 encoders | 1,44E-09 |

In a worst case scenario, the sensor subsystem's characteristic value MTTFd is calculated from the inferior (lower) value of the two sensors.

Safety relays PNOZsigma PNOZ s30

Achievable safety level

| Safety function | PL in accordance with EN ISO 13849-1: 2015 | SIL CL in accordance with EN IEC 62061 |
|------------------------------------|--|--|
| Direction Position | PL c (Cat. 1) | - |
| Speed Speed range Standstill | PL e (Cat.4) | 3 |

Please note:

For the "sensor" subsystem, a minimum speed must be exceeded within forced dynamisation.

The minimum speed depends on the ratio of the frequency at tracks AB " f_{AB} " to the frequency at track Z " f_Z " in your configuration (**f_{AB}/f_Z Verh.** setting in the menu) and is calculated as follows:

- ▶ when **f_{AB}/f_Z Verh.** ≥ 1.0
 $f_Z = 70$ mHz or $f_{AB} = (f_{AB}/f_Z) \times 70$ mHz
- ▶ when **f_{AB}/f_Z Verh.** < 1.0
 $f_{AB} = 70$ mHz or $f_Z = 70$ mHz/ (f_{AB}/f_Z)

At the very latest, a feasibility error will be detected when a tolerance expires. The tolerance level depends on the ratio of the frequency at tracks AB " f_{AB} " to the frequency at track Z " f_Z " in your configuration (**f_{AB}/f_Z Verh.** setting in the menu) and is calculated as follows:

- ▶ when **f_{AB}/f_Z Verh.** ≥ 1.0
7.5 Z-pulses or $7.5 \times (f_{AB}/f_Z)$ AB-pulses
- ▶ when **f_{AB}/f_Z Verh.** < 1.0
4.5 AB-pulses or $4.5/(f_{AB}/f_Z)$ Z-pulses

Safety-related characteristic data for operation with 2 proximity switches

Permitted encoder types and output signals

Non-safety-related rotary encoder

Permitted encoder types:

- ▶ Inductive proximity switches

Permitted output circuits:

- ▶ pnp
- ▶ npn

Safety relays PNOZsigma PNOZ s30

Safety-related architecture

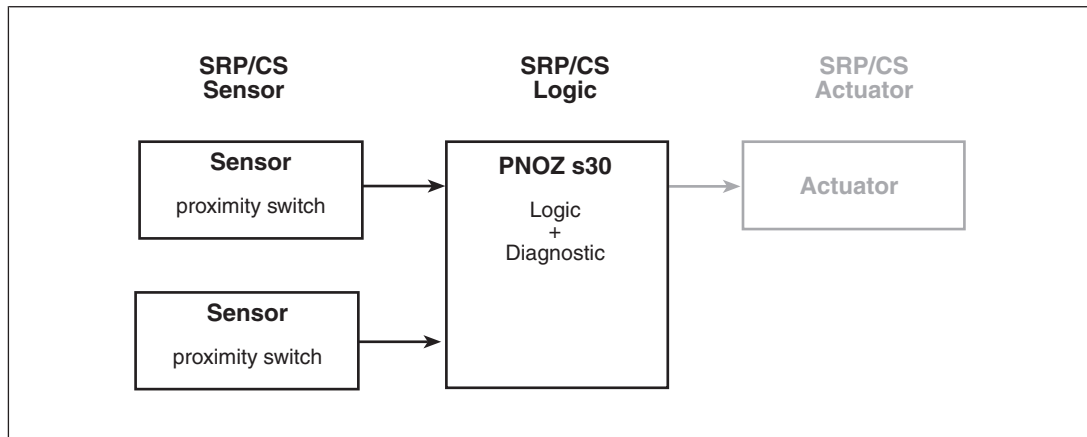

To calculate the safety function you will need the following data for the "sensor" subsystem and "PNOZ s30" subsystem:

| Sensor | | | PNOZ s30 subsystem | |
|----------|-----------------------|------|--------------------------|-----------|
| Category | MTTFd | DC | Operating mode | PFH (1/h) |
| 4 | Manufacturer-specific | 90 % | Monitoring 2 encoders | 1,44E-09 |

In a worst case scenario, the sensor subsystem's characteristic value MTTFd is calculated from the inferior (lower) value of the two sensors.

Achievable safety level

| Safety function | PL in accordance with EN ISO 13849-1: 2015 | SIL CL in accordance with EN IEC 62061 |
|------------------------------------|--|--|
| Direction Position | - | - |
| Speed Speed range Standstill | PL e (Cat.4) | 3 |

Please note:

Common cause failures (CCF) are possible for the sensor subsystem. An appropriate analysis must be carried out.

To use proximity switches 1 and 2 we recommend that you:

- ▶ Use different technologies/design or physical principles (e.g. different manufacturers) and
- ▶ Evaluate the encoder supply via track S

Safety relays PNOZsigma PNOZ s30

Examples

Connection of proximity switch

Features

PNOZ s30

- ▶ Standstill monitoring for enabling the safety gate via Rel. 1:
Standstill is detected at ≤ 2 Hz, the output Rel. 1 switches on and the safety gate can be released with the pushbutton S3.
- ▶ Monitoring for overspeed via Rel. 2:
Overspeed is detected at ≥ 500 Hz and the output Rel. 2 switches off.
- ▶ Feedback loop monitoring for Rel.1 via feedback loop input Y1,
Feedback loop monitoring for Rel.2 via feedback loop input Y2
- ▶ Automatic reset

Encoder

The measured values are detected by two proximity switches (pnp).

PNOZ s4

- ▶ Safety gate monitoring

Configuration overview

| | | | | | | | | | | | | | | | | | |
|---|-----------------------|--|-------------------|-------------------|--------|--------|----------------|----------------|----------------|-------------------------------------|------|---|-------------|--|--|--|--|
| language | English | | input device | A: pnp / B: pnp | | | | | | global standstill (10 mHz-1 MHz) | 2 Hz | | | | | | |
| delay time start-up (0-600s) | Hysteresis (0-50%) | | F1 | F2 | F3 | F4 | F5 | F6 | F7 | F8 | F9 | input device settings (10 mHz-1 MHz) | f max (A/B) | | 3000 kHz | | |
| units | P0 | | Standstill | 500 Hz | | | | | | | | f max (Z) | | | ratio (0,0001-400,000:1) | | |
| conversion | P1 | | | | | | | | | | | | | | position window width (1-24.900.000 Imp) | | |
| mode select input | P2 | | | | | | | | | | | | Pos. 1 | | | incorrect direction (max. wrong) direction (1-24.900.000 Imp) | |
| Sel 1 (Y10) Sel 2 (Y11) Sel 3 (Y12) Sel 4 (Y13) | P3 | | | | | | | | | | | | Pos. 2 | | | direction left | |
| | P4 | | | | | | | | | | | | Pos. 3 | | | max. right | |
| | P5 | | | | | | | | | | | | Pos. 4 | | | direction right | |
| | P6 | | | | | | | | | | | | | | | max. left | |
| delay time select input (0-30s) | P7 | | | | | | | | | | | | | | name of configuration | | |
| assign outputs (functions) delay time effect (outputs) delay time 0 - 30s (outputs) reset mode | P8 | | | | | | | | | | | | | | Example 1 | | |
| | P9 | | | | | | | | | | | | | | CRC of configuration | | |
| | P10 | | | | | | | | | | | | | | | | |
| output out logic | P11 | | | | | | | | | | | | | | | | |
| | P12 | | | | | | | | | | | | | | | | |
| | P13 | | | | | | | | | | | | | | | | |
| | P14 | | | | | | | | | | | | | | | | |
| | P15 | | | | | | | | | | | | | | | | |
| | | | Rel. 1 (13/14) | Rel. 2 (23/24) | Ext. 1 | Ext. 2 | Out 1 (Y32) | Out 2 (Y33) | Out 3 (Y34) | Out 4 (Y35) | | | | | | | |
| | | | F1 | F2 | | | | | | | | | | | | | |
| | | | automatic | automatic | | | | | | | | | | | | | |

Safety relays PNOZsigma PNOZ s30

Connection

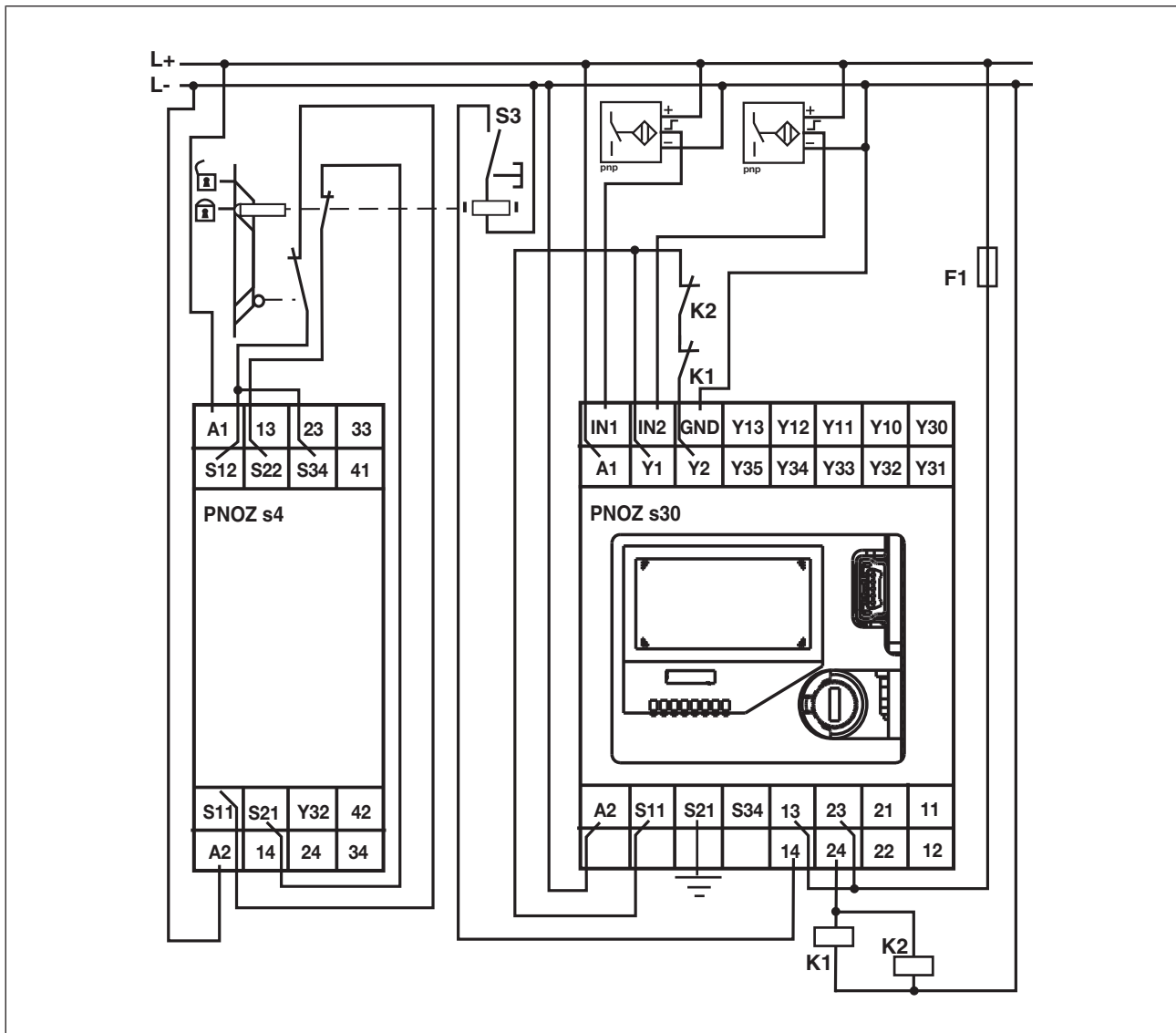

Safety relays PNOZsigma PNOZ s30

Incremental encoder connection

Features

PNOZ s30

- ▶ Speed monitoring:
Monitoring for overspeed for the operating modes "Setup" and "Automatic", which are selected with the switch S1.
 - The operating mode "Setup" is selected if the select input SEL1 is activated. Overspeed is detected during setup at ≥ 50 Hz and the output Rel. 2 switches off.
 - The operating mode "Automatic" is selected if the select input SEL2 is activated. Overspeed is detected during automatic mode at ≥ 3000 Hz and the output Rel. 2 switches off.
 - If a speed of 2800 Hz is exceeded, the semiconductor output Out1 switches in automatic mode and a message (advance warning) is output via the PLC.
- ▶ Standstill monitoring:
Standstill is detected at ≤ 2 Hz for both operating modes and the output Rel. 1 switches on.
- ▶ Feedback loop monitoring via feedback inputs Y1 and Y2

Encoder:

The measured values are detected by an incremental encoder (sin/cos)

Safety relays PNOZsigma PNOZ s30

Configuration overview

| | | | | | | | | | | | | | | | |
|---------------------------------|---------|-----------------------|-------------------|-------------------|---------|--------|-----------------|-----------------|-----------------|-----------------|----|--|--|--|--------|
| language | English | input device | | | | | | | | Sin/cos 1Vss | | | | global standstill (10 mHz-1 MHz) | 2 Hz |
| delay time start-up (0-600s) | | Hysteresis (0-50%) | | | | | | | | | | | | input device settings (10 mHz-1 MHz) | |
| units | | | F1 | F2 | F3 | F4 | F5 | F6 | F7 | F8 | F9 | | | f max (A/B) | 20 kHz |
| conversion | | P0 | | | | | | | | | | | | f max (Z) | |
| mode select input | 1 of 4 | P1 | Standstill | 50 Hz | 50 Hz | | | | | | | | | ratio (0,0001-400.000:1) | |
| Sel 1 (Y10) | | P2 | Standstill | 3000 Hz | 2800 Hz | | | | | | | | | position window width (1-24.900.000 Imp) | |
| Sel 2 (Y11) | | P3 | | | | | | | | | | | | Pos. 1 | |
| Sel 3 (Y12) | | P4 | | | | | | | | | | | | Pos. 2 | |
| Sel 4 (Y13) | | P5 | | | | | | | | | | | | Pos. 3 | |
| delay time select input (0-30s) | 20 ms | P6 | | | | | | | | | | | | Pos. 4 | |
| | | P7 | | | | | | | | | | | | incorrect direction (max. wrong) direction (1-24.900.000 Imp) | |
| | | P8 | | | | | | | | | | | | direction left | |
| | | P9 | | | | | | | | | | | | max. right | |
| | | P10 | | | | | | | | | | | | direction right | |
| | | P11 | | | | | | | | | | | | max. left | |
| | | P12 | | | | | | | | | | | | name of configuration | |
| | | P13 | | | | | | | | | | | | Example 2 | |
| | | P14 | | | | | | | | | | | | CRC of configuration | |
| | | P15 | | | | | | | | | | | | | |
| | | | | | | | | | | | | | | | |
| assign outputs (functions) | | | Rel. 1 (13/14) | Rel. 2 (23/24) | Ext. 1 | Ext. 2 | Out. 1 (Y32) | Out. 2 (Y33) | Out. 3 (Y34) | Out. 4 (Y35) | | | | | |
| delay time effect (outputs) | | | F1 | F2 | | | F3 | | | | | | | | |
| delay time 0-30s (outputs) | | | | | | | | | | | | | | | |
| reset mode | | | automatic | automatic | | | automatic | | | | | | | | |
| output out logic | | | | | | | normally off | | | | | | | | |

Safety relays PNOZsigma PNOZ s30

Connection

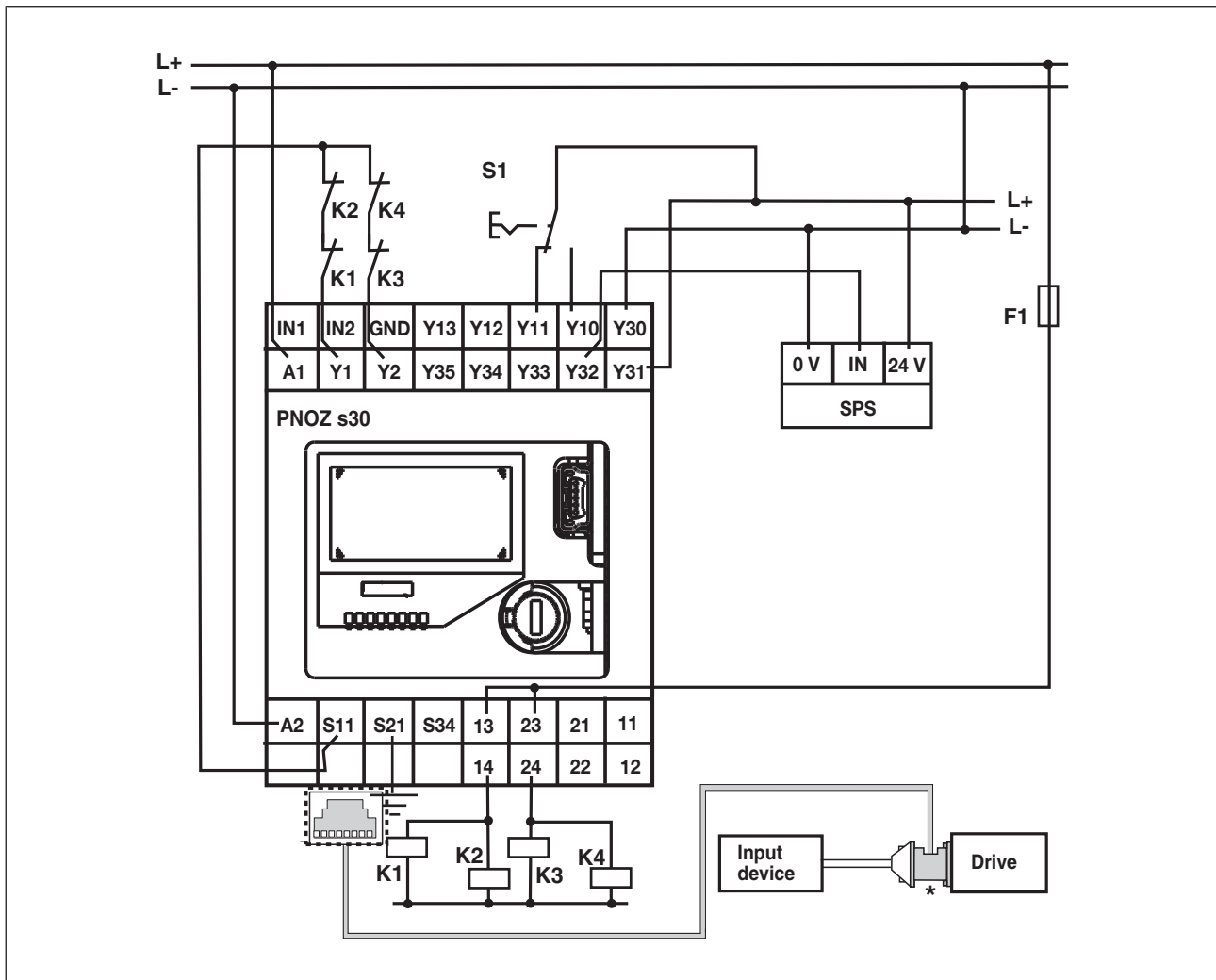

* The PNOZ msi adapters are available from Pilz as accessories

Safety relays PNOZsigma PNOZ s30

Order reference

Product

| Product type | Features | Terminals | Order No. |
|--------------|-----------------|------------------------------|-----------|
| PNOZ s30 | 24 - 240 VAC/DC | With screw terminals | 750 330 |
| PNOZ s30 C | 24 - 240 VAC/DC | With spring-loaded terminals | 751 330 |

Accessories

| Product type | Features | Order No. |
|-------------------------------------|---|-----------|
| PNOZ s terminator plug | Terminator, x10 | 750 010 |
| PNOZmulti Chipcard | Chip card, 8 kB | 779 201 |
| PNOZmulti Chipcard Set | Chip card, 8 kB, x10 | 779 200 |
| PNOZmulti Chipcard | Chip card, 32 kB | 779 211 |
| PNOZmulti Chipcard Set | Chip card, 32 kB, x10 | 779 212 |
| Chipcard Holder | Chip card holder | 779 240 |
| PNOZmulti Seal | Chip card seal, x10 | 779 250 |
| PNOZ s Set3 Screw Loaded Terminals | Set of plug-in screw terminals, x1 | 750 014 |
| PNOZ s Set3 Spring Loaded Terminals | Set of plug-in spring terminals, x1 | 751 014 |
| PNOZ msi1Ap | Adapter and cable 25-pin, 2.5 m | 773 840 |
| PNOZ msi1Ap | Adapter and cable 25-pin, 5.0 m | 773 844 |
| PNOZ msi1Bp | Adapter and cable 25-pin, 2.5 m | 773 841 |
| PNOZ msi1Bp | 25-pin, 5.0 m | 773 839 |
| PNOZ msi3Ap | Adapter and cable 15-pin, 2.5 m | 773 842 |
| PNOZ msi3Bp | Adapter and cable 15-pin, 2.5 m | 773 843 |
| PNOZ msi5p | Adapter and cable Bos/Rex 15-pin, 2.5 m | 773 857 |
| PNOZ msi5p | Adapter and cable Bos/Rex 15-pin, 1.5 m | 773 858 |
| PNOZ msi6p | Adapter and cable Elau 9-pin, 7.5 m | 773 859 |
| PNOZ msi6p | Adapter and cable Elau 9-pin, 2.5 m | 773 860 |
| PNOZ msi6p | Adapter and cable Elau 9-pin, 1.5 m | 773 861 |
| PNOZ msi7p | Adapter and cable SEW 15-pin, 2.5 m | 773 864 |
| PNOZ msi7p | Adapter and cable SEW 15-pin, 1.5 m | 773 865 |
| PNOZ msi8p | Adapter and cable Lenze 9-pin, 2.5 m | 773 862 |
| PNOZ msi8p | Adapter and cable Lenze 9-pin, 1.5 m | 773 863 |
| PNOZ msi9p | Adapter cable 5.0 m | 773 856 |

Safety relays PNOZsigma PNOZ s30

| Product type | Features | Order No. |
|--|--|-----------|
| PNOZ msi10p | Adapter cable 2.5 m | 773 854 |
| PNOZ msi11p | Adapter cable 1.5 m | 773 855 |
| PNOZ msi19p | Connection cable, 1.5 m | 773 846 |
| PNOZ msi19p | Connection cable, 2.5 m | 773 847 |
| PNOZ msi S09 | 9-pin adapter, connector set | 773 870 |
| PNOZ msi S15 | 15-pin adapter, connector set | 773 871 |
| PNOZ msi S25 | 25-pin adapter, connector set | 773 872 |
| PNOZ Chip Card Reader | Chip card reader for saving the configuration on the computer | 779 230 |
| SmartCardCommander with SIM card adapter | Software for the chip card reader 779 230, for saving the configuration on the computer | 750 031 |
| PNOZsigma Chip Card manager set | Set consisting of the PNOZ Chip Card Reader and SmartCardCommander with SIM card adapter (779 230 and 750 030) | 750 030 |

Safety relays PNOZsigma PNOZ s50

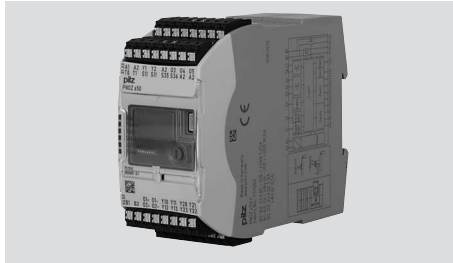

Overview

Unit structure

Scope of supply

- ▶ PWM relay PNOZ s50
- ▶ Connection terminals (spring-loaded terminals)
- ▶ Chip card
- ▶ Chip card holder
- ▶ Documentation on data medium

Unit features

Using the product PNOZ s50:

PWM relay for the safe activation of inductive loads, e.g. valves, mechanical holding brakes.

The product has the following features:

- ▶ Semiconductor outputs
 - 2 dual-pole failsafe power outputs, rated voltages 24 V or 48 VDC, e.g. for mechanical holding brakes, valves
 - Output voltage can be reduced through pulse width modulation (PWM)
 - Potential of the power outputs connected to the supply voltage B1/B2
 - 1 single-pole failsafe output for error
 - 2 single-pole failsafe outputs for status of the power circuits
 - 2 test pulse outputs
 - Potential of the single-pole outputs connected to supply voltage A1/A2
- ▶ Semiconductor inputs
 - 4 failsafe inputs for activating the power outputs (fast shutdown of power circuits)
 - 2 single-pole standard inputs for activating the power outputs (slow shutdown of power circuits)

Safety relays PNOZsigma PNOZ s50

- 2 single-pole standard inputs for feedback loops
Potential of the semiconductor inputs connected to supply voltage A1/A2
- ▶ Supply voltage
 - 24 VDC for device
 - For power circuits, rated voltage 24 V, 48 VDCSupply voltage for device and power circuit are isolated from each other
- ▶ Voltage output 24 VDC
Potential connected to supply voltage A1/A2
- ▶ Can be configured via the display on the device
- ▶ Configuration is stored on a chip card
- ▶ Display
 - Number of operations
 - System information
 - Status of the inputs and outputs
 - Warning and error messages
- ▶ Status and fault LEDs
- ▶ Plug-in connection terminals (spring-loaded terminals)

Safety relays PNOZsigma PNOZ s50

Front/side view

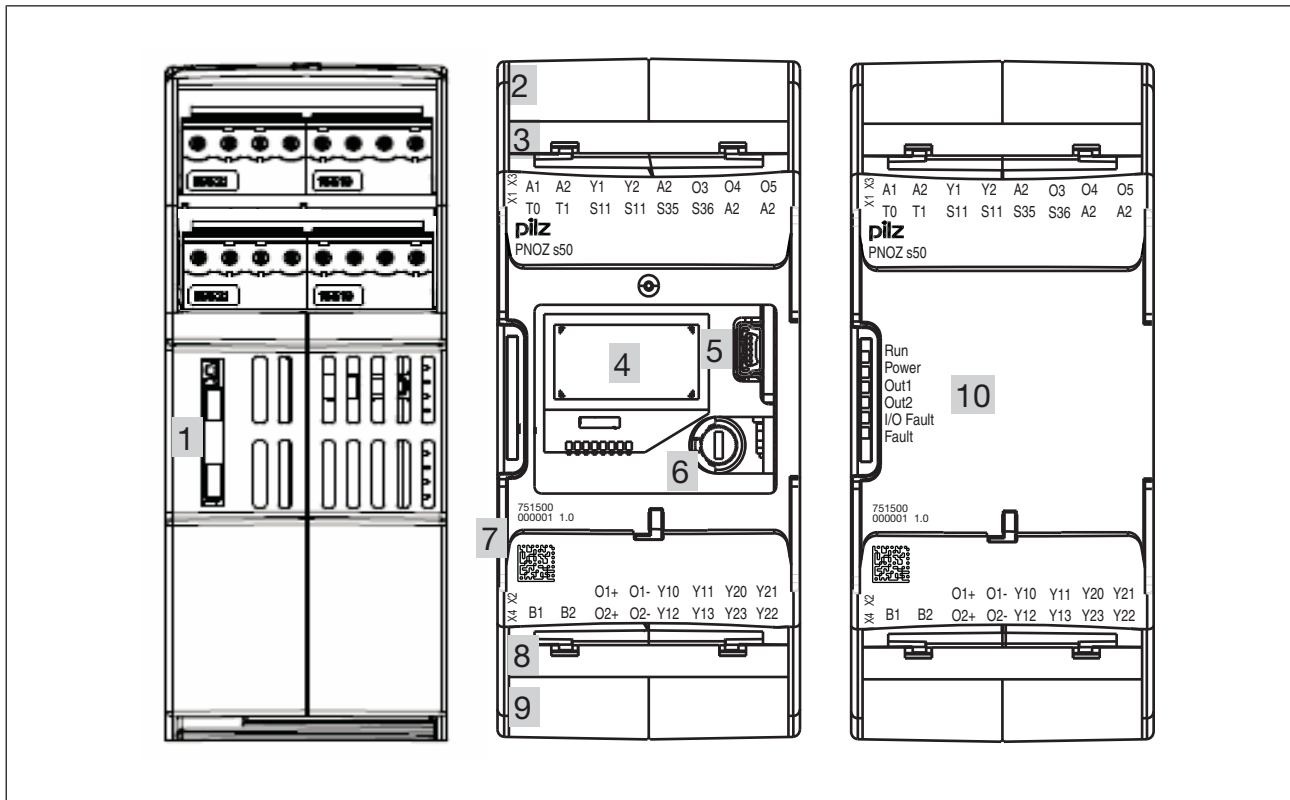

Fig.: Left: Side view, centre: Front view without cover, right: Front view with cover

Legend:

- ▶ 1: Chip card
- ▶ 2: Connection terminal X3
- ▶ 3: Connection terminal X1
- ▶ 4: Display
- ▶ 5: 4-pin socket (service only)
- ▶ 6: Rotary knob
- ▶ 7: Labelling strip with:
 - Order number
 - Serial number
 - Hardware version number
 - 2D code
- ▶ 8: Connection terminal X2
- ▶ 9: Connection terminal X4
- ▶ 10: LEDs

Safety relays PNOZsigma PNOZ s50

Function description

Introduction

The PWM relay PNOZ s50 is used for the safety-related shutdown of inductive loads.

It has two power outputs to activate two independent, inductive loads. Each power circuit is switched independently by two inputs. Two feedback loops monitor the switch status of the inductive loads. Two failsafe outputs signal the switch status of the inductive loads to the higher level safety control system. A failsafe fault signal output signals any fault to a higher level safety control system.

The device is configurable. All the parameters can be set via a rotary knob with pushbutton. The state of the inputs and outputs, the configuration and any faults are shown on a display. The configuration is stored on a chip card.

There is an integrated counter, which records the number of operations for each power circuit.

Block diagram

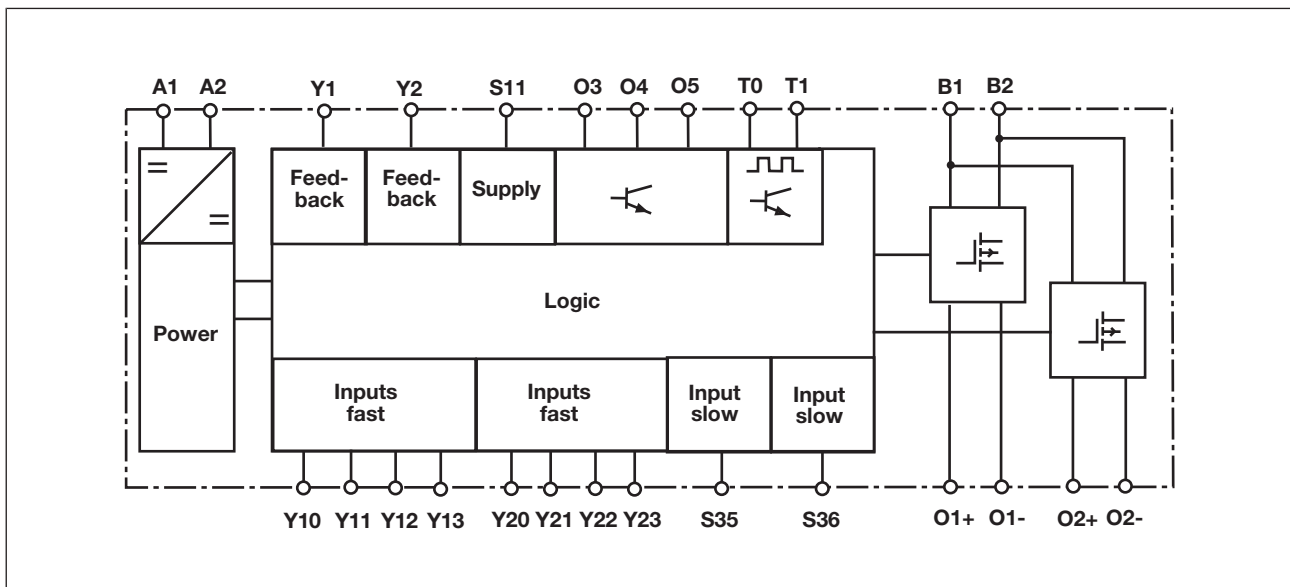

Fig.: Block diagram

Potential isolation, potential connection:

- ▶ Potential isolation between the supply voltages A1/A2 and B1/B2.
- ▶ Potential connection between the power outputs O1+/O1-, O2+/O2- and the supply voltage B1/B2.
- ▶ Potential connection between the semiconductor inputs and single-pole outputs, voltage output and supply voltage A1/A2.

Safety relays PNOZsigma PNOZ s50

Functions

Switching the power circuits on and off (fast shutdown)

The device has two safe dual-pole outputs O1+/O1- (power circuit 1) and O2+/O2- (power circuit 2), which can be switched using inputs Y10/Y11 (power circuit 1) and Y20/Y21 (power circuit 2):

- ▶ Switch-on (brake is ventilated):
 - O1+/O1- is switched on when there is a "1" signal (24 VDC) at Y10 **and** Y11.
 - O2+/O2- is switched on when there is a "1" signal (24 VDC) at Y20 **and** Y21.
 - Partial operation is not time-monitored. An output will not switch until both the corresponding inputs are "1".
- ▶ Switch-off (brake is applied):
 - O1+/O1- is switched off safely when there is a "0" signal (0 VDC) at Y10 **and/or** Y11.
 - O2+/O2- is switched off safely when there is a "0" signal (0 VDC) at Y20 **and/or** Y21.

| Power circuit 1 | Y10 | Y11 | O1+, O1- | |
|-----------------|-----|-----|----------|---|
| | 1 | 1 | 1 | Load under current (power circuit 1 switched on) |
| | 1 | 0 | 0 | Load without current (power circuit 1 switched off) |
| | 0 | 1 | 0 | |
| | 0 | 0 | 0 | |
| Power circuit 2 | Y20 | Y21 | O2+, O2- | |
| | 1 | 1 | 1 | Load under current (power circuit 2 switched on) |
| | 1 | 0 | 0 | Load without current (power circuit 2 switched off) |
| | 0 | 1 | 0 | |
| | 0 | 0 | 0 | |

The power circuits are supplied via the terminals B1/B2 with the voltage U_{B1B2} (voltage range: rated voltage 24 V, 48 VDC).

Safety relays PNOZsigma PNOZ s50

Both poles are switched (e.g. O1+, O1-).

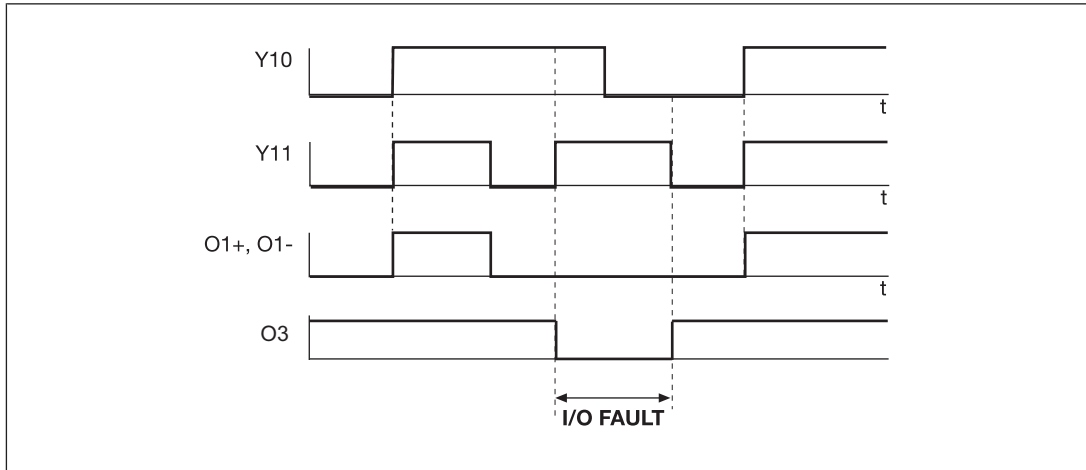

Fig.: Start-up condition for inputs Y10/Y11

After the output O1+/O1- and/or O2+/O2- is switched on, the voltage U_{B1B2} is available for a configurable overexcitation time U_{over} . Once the overexcitation time t_{over} has elapsed, the voltage is reduced through pulse width modulation (PWM). The overexcitation time t_{over} and the reduced voltage U_{Avg} are configured via the display.

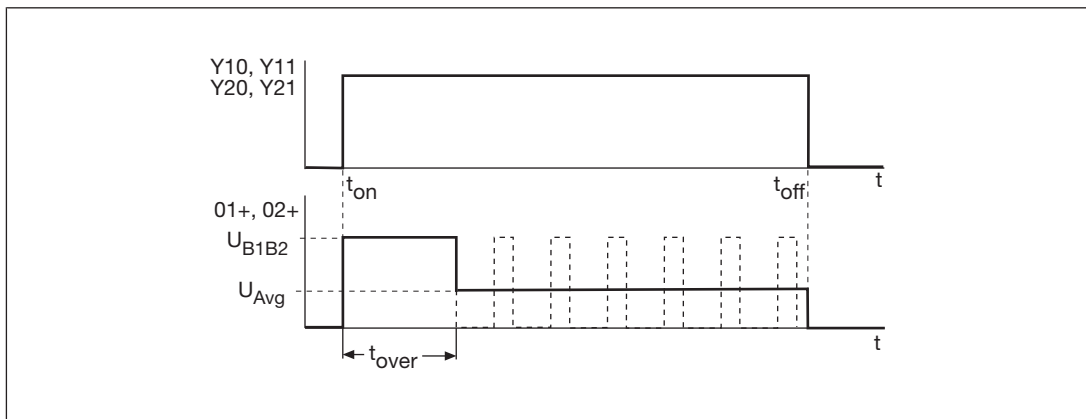

Fig.: Switching the power circuits on and off

Legend:

- ▶ Y10, Y11, Y20, Y21: Safe inputs to switch the outputs O1+, O2+
- ▶ O1+, O2+: Safe outputs, power circuit 1 and 2
- ▶ U_{B1B2} : Supply voltage to the power circuits
- ▶ t_{on} : Switch on power circuit
- ▶ t_{over} : Configured overexcitation time
- ▶ t_{off} : Switch off power circuit
- ▶ U_{Avg} : Configured reduced voltage (arithmetic mean of the voltage at the outputs once the overexcitation time has elapsed)

Inputs Y10, Y11 (or Y20, Y21) can be activated via single-pole or dual-pole safe outputs.

Safety relays PNOZsigma PNOZ s50

Switching the power circuits on and off (slow shutdown S35, S36)

If the switching times are not critical, the loads at the power circuits can also be shut down slowly. A connected brake is permitted to have longer application times, for example. The brake switches with lower noise and is lower wearing.

A 1/0 pulse edge at one of the slow shutdown inputs (S35 or S36) switches off the corresponding power circuit (O1+, O2+) in single-pole mode. A flywheel diode means that the current only dissipates the magnetic field slowly.

| | | |
|-----------------|----------------|------------------------------|
| Power circuit 1 | S35 | O1+, O1- |
| | 1/0 pulse edge | Switches off power circuit 1 |
| Power circuit 2 | S36 | O2+, O2- |
| | 1/0 pulse edge | Switches off power circuit 2 |

Conditions for fast and slow shutdown

To shut down the power circuits, the following conditions must be met:

| Shutdown | Y10/Y11 | S35 | O1+/O1- |
|----------|----------------|----------------|---------|
| Fast | 1/0 pulse edge | 1 | -> 0 |
| Slow | 1 | 1/0 pulse edge | -> 0 |

| Shutdown | Y20/Y21 | S36 | O2+/O2- |
|----------|----------------|----------------|---------|
| Fast | 1/0 pulse edge | 1 | -> 0 |
| Slow | 1 | 1/0 pulse edge | -> 0 |

Safety relays PNOZsigma PNOZ s50

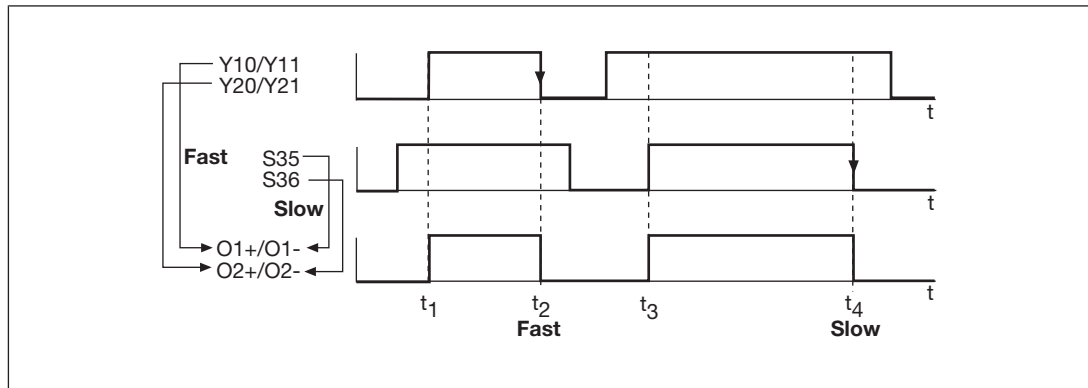

Fig.: Conditions for fast and slow shutdown

Legend:

- ▶ Fast: Fast shutdown
- ▶ Slow: Slow shutdown
- ▶ t_1 and t_3 Switch-on: Y10, Y11, S35 = 1, O1+/O1- switches on; Y20, Y21, S36 = 1, O2+/O2- switches on
- ▶ t_2 : Fast shutdown via 1/0 pulse edge from Y10/Y11 or Y20/Y21
- ▶ t_4 : Slow shutdown via 1/0 pulse edge from S35 or S36

Feedback loop Y1, Y2

The operating state of the inductive load can be uploaded, for example, via

- ▶ Micro switches
- ▶ Proximity switches
- ▶ Hall sensors

The feedback loop can be configured for N/C or N/O contacts.

The 24 V voltage outputs S11 of the PNOZ s50 can be used to provide the 24 V DC supply to the equipment in the feedback loop. This is only permitted if test pulses are not used. Otherwise a wiring error will be registered.

The feedback loop will only be evaluated after a max. ventilation and application time, which is to be configured. Contact bounce during application or ventilation of the equipment is ignored.

- ▶ Max. ventilation time: Period within which the load must be ventilated once the power circuit is switched on.
- ▶ Max. application time: Period within which the load must be applied once the power circuit is switched off.

The max. ventilation and application time, plus the switch-on behaviour (N/C / N/O) are configured via the display. The max. application time is configured separately for slow and fast shutdown. The max. ventilation time is configured jointly for slow and fast shutdown.

Safety relays PNOZsigma PNOZ s50

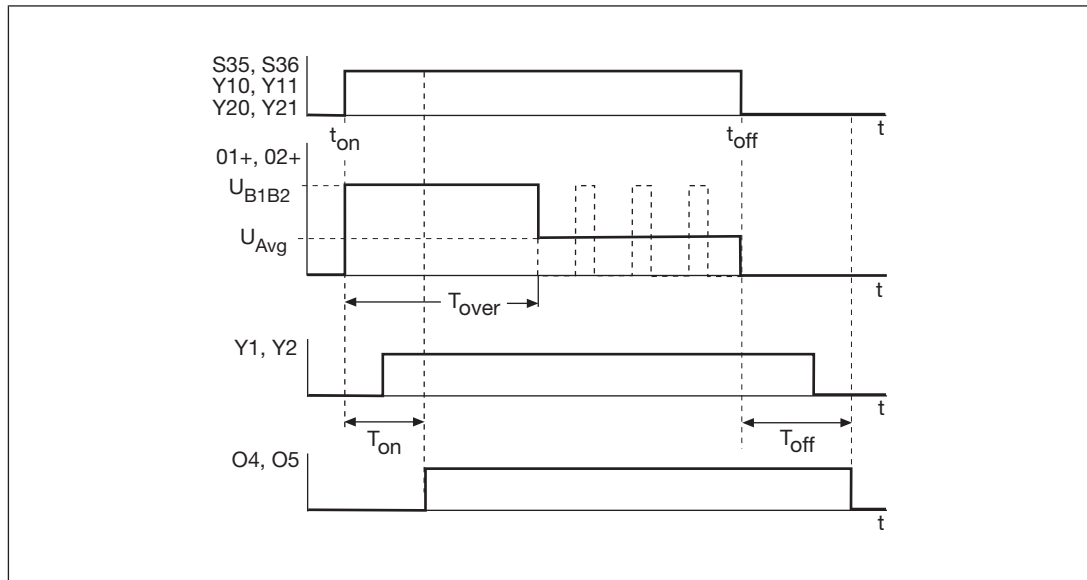

Fig.: Ventilation and application time

Legend:

- ▶ Y10, Y11, Y20, Y21: Safe inputs to switch the outputs O1+/O1-, O2+/O2-
- ▶ O1+, O2+: Safe outputs, power circuit 1 and 2
- ▶ U_{B1B2} : Supply voltage to the power circuits
- ▶ t_{on} : Switch on power circuit
- ▶ t_{over} : Configured overexcitation time
- ▶ t_{off} : Switch off power circuit
- ▶ U_{Avg} : Configured reduced voltage (arithmetic mean of the voltage at the outputs once the overexcitation time has elapsed)
- ▶ Y1, Y2: Feedback loops
- ▶ T_{on} : Configured duration of max. ventilation time
- ▶ T_{off} : Configured duration of max. application time
- ▶ O4, O5: Failsafe outputs for status of the load, change in state after T_{on} and T_{off} have elapsed

Safety relays PNOZsigma PNOZ s50

Test pulse outputs T0, T1

Feedback loops Y1 and Y2 can be assigned test pulses. The PNOZ s50 has 2 test pulse outputs, T0 and T1.

Please note the fixed allocation of test pulses to the following inputs:

- ▶ T0 pulses the feedback loop Y1
- ▶ T1 pulses the feedback loop Y2

The test pulse outputs T0/T1 are switched on (24 V) in

- ▶ "RUN" operating status.
- ▶ "I/O Fault" operating status (fault on inputs and outputs).

The test pulse outputs T0/T1 are switched off (0 V) in

- ▶ "Fault" operating status (internal fault).

The test pulses can be switched on and off via the display.

- ▶ The default setting is for test pulses to be switched on.
- ▶ Test pulses will not be active in the event of a fault (I/O Fault and Fault).

Signal and status outputs O3, O4, O5

Single-pole failsafe semiconductor outputs signal the operating status of the load and indicate a fault.

| | | |
|--|-----------|--|
| Fault signal output | O3 | |
| | 1 | No fault, LED "I/O Fault" and "Fault" is off |
| | 0 | Fault, LED "I/O Fault" or "Fault" is lit |
| Status outputs They signal the status of the load only after the ventilation or application time has elapsed. | O4 | |
| | 1 | Load at O1+/O1- ventilated |
| | 0 | Load at O1+/O1- applied |
| | O5 | |
| | 1 | Load at O2+/O2- ventilated |
| | 0 | Load at O2+/O2- applied |

Safety relays PNOZsigma PNOZ s50

Output test

Outputs that are switched on are checked via regular off tests.

- ▶ Test pulses for outputs that are switched on: see technical details
- ▶ Outputs that are switched on are switched off for the duration of the test pulse.
- ▶ The load must not switch off because of the test.
- ▶ The switch-off tests cannot be turned off.

Dual-pole outputs that are switched off are checked via regular on tests.

- ▶ The test pulses switch the positive pole of the output. The load must not switch on because of the test.

Testing for shorts

- ▶ A test is regularly carried out to check for shorts between the outputs.

Status display, configuration and messages

Overview

The configuration is set using the device's rotary knob with pushbutton and is then displayed. Access to the configuration menu is password-protected.

The following device properties can be configured:

- ▶ Supply voltage to the power circuits
- ▶ Signals to the outputs of the power circuits:
 - Overexcitation time
 - Reduced voltage
- ▶ Feedback loop:
 - Max. ventilation and application time
 - High or low logic (N/O or N/C)
 - Evaluation of test pulses
- ▶ Offset (start value) for the number of operations

Additional information on the display:

- ▶ Status display
- ▶ Number of operations
- ▶ States of inputs and outputs
- ▶ Information on the device
- ▶ Software versions
- ▶ Error messages

Safety relays PNOZsigma PNOZ s50

Chip card

The set parameters, the device ID and the check sum for device configuration are stored on the chip card (for further information see chapter entitled "Commissioning", under "Use chip card [ 913]").

Reaction time

The reaction time (see [Technical details \[!\[\]\(fa6f3af6bfa46c5d4a2d362681095beb_img.jpg\) 934\]](#)) of the PNOZ s50 is the time between a signal changing at the inputs for fast (Y10/Y11, Y20/Y21) or slow shutdown (S35, S36) and the signal changing at the outputs of the power circuit (O1+/O1-, O2+/O2-). The reaction time takes into account the input filter time, temperature drift and spread of components.

To determine the plant's overall reaction times, the corresponding internal processing times of the higher level safety control system and connected load must also be considered.

Installation

General installation guidelines

Control cabinet installation

- ▶ The unit should be installed in a control cabinet with a protection type of at least IP54.
- ▶ Fit the device to a horizontal DIN rail. The venting slots must face upwards and downwards. Other mounting positions could destroy the device.
- ▶ Use the locking element on the rear of the device to attach it to the DIN rail.
- ▶ Push the device upwards or downwards before lifting it from the DIN rail.

Dimensions

*with spring-loaded terminals

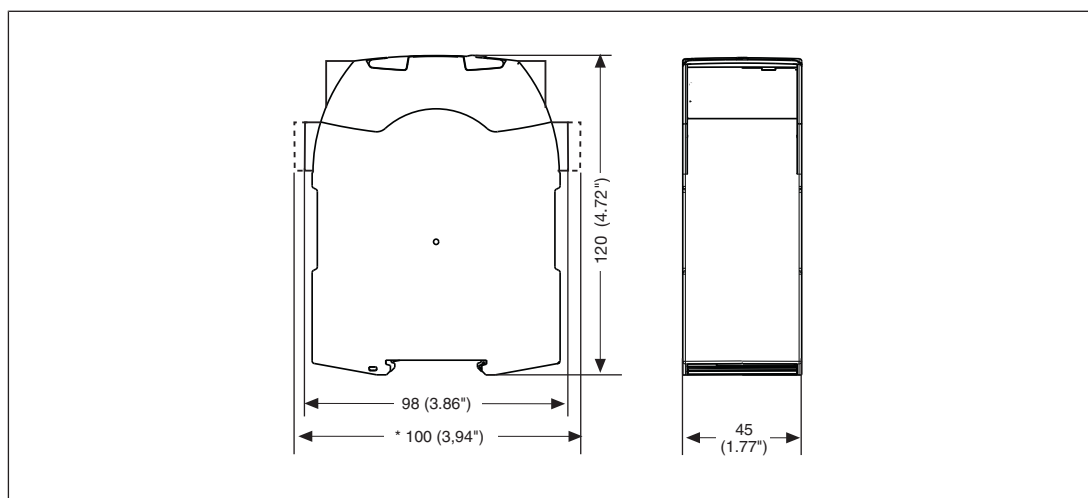

Safety relays PNOZsigma PNOZ s50

Mounting distances

Depending on the ambient temperature, with control cabinet installation it may be necessary to maintain a certain distance from the top and bottom, as well as to other heat-producing devices (see diagram).

The values stated for the mounting distances are minimum specifications. Details of whether a distance needs to be maintained can be found in the section entitled "[Supplementary data \[938\]](#)".

Air conditioning may otherwise be required.

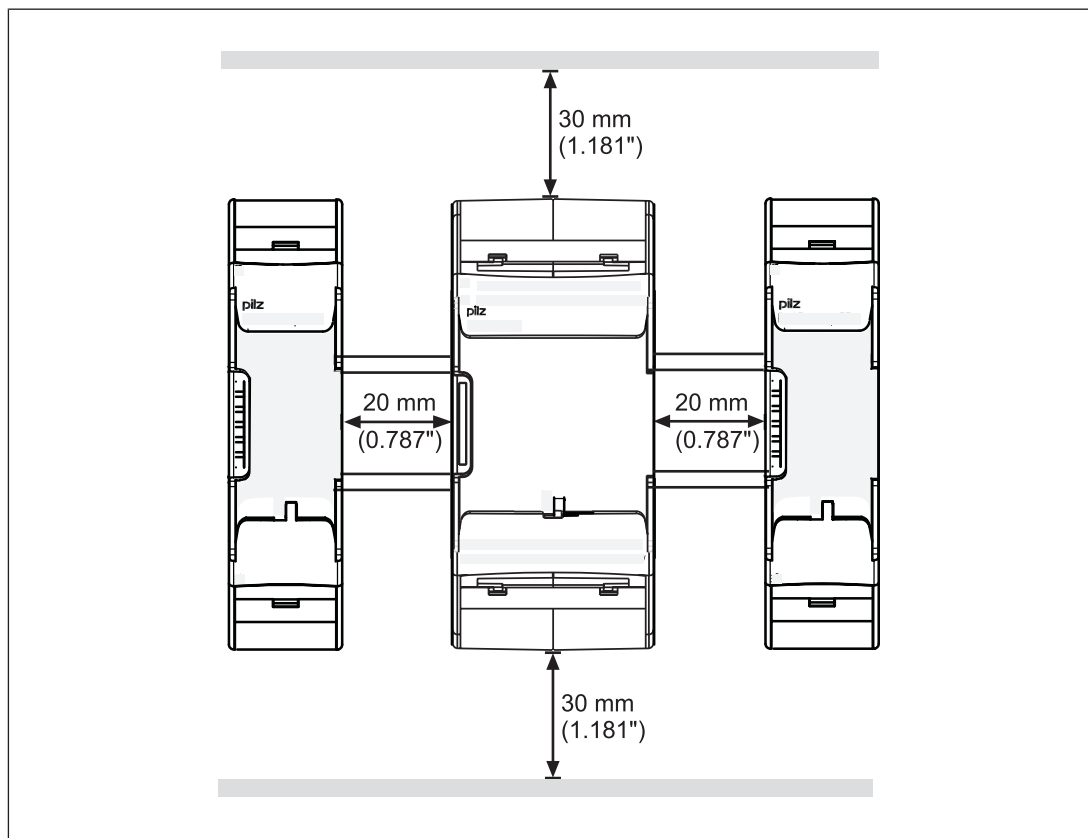

Fig.: Mounting distances for the PNOZ s50

Safety relays PNOZsigma PNOZ s50

Commissioning

Wiring

General wiring guidelines

Note:

- ▶ Information given in the "Technical details" must be followed.
- ▶ Use copper wire that can withstand 75 °C.
- ▶ The wiring must be designed to achieve sufficient noise immunity and protection against noise emissions in terms of EMC. Please also refer to DIN EN 60204-1 (Electrical equipment of machines).

Inputs

- ▶ Appropriate wiring must be used to exclude short circuits between the inputs or to a supply line!

Outputs

- ▶ If short circuits occur between the cable from the output to the load and a supply line, it will no longer be possible to switch off the load.

Possible remedy: Exclude the error by using separate multicore cable for supply voltages

- ▶ Use appropriate wiring to exclude short circuits between the outputs!

Pin assignment

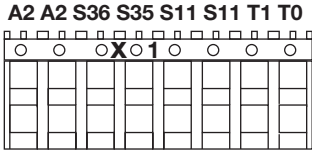
| Female connector X1 | Terminal | Description |
|---|----------|---|
|  | A2 | Reference potential for - Device's supply voltage - Inputs - Fault signal and status outputs |
| | S36 | Standard input for slow shutdown, power circuit 2 |
| | S35 | Standard input for slow shutdown, power circuit 1 |
| | S11 | Voltage output 24 VDC |
| | S11 | Voltage output 24 VDC |
| | T1 | Test pulse output 1 |
| | T0 | Test pulse output 0 |

Safety relays PNOZsigma PNOZ s50

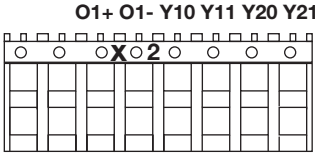
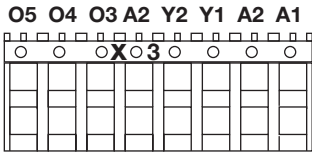
| Female connector X2 | Terminal | Description |
|--|----------|---|
|  | O1+ | Failsafe output for power circuit 1, positive |
| | O1- | Failsafe output for power circuit 1, negative |
| | Y10 | Failsafe input for fast shutdown, power circuit 1 |
| | Y11 | Failsafe input for fast shutdown, power circuit 1 |
| | Y20 | Failsafe input for fast shutdown, power circuit 2 |
| | Y21 | Failsafe input for fast shutdown, power circuit 2 |
| Female connector X3 | Terminal | Description |
|  | O5 | Failsafe output for status, power circuit 2 |
| | O4 | Failsafe output for status, power circuit 1 |
| | O3 | Failsafe output for fault signal |
| | A2 | 0 V supply voltage for device |
| | Y2 | Standard input for feedback loop 2 |
| | Y1 | Standard input for feedback loop 1 |
| | A2 | 0 V supply voltage for device |
| | A1 | 24 VDC supply voltage for device |

Safety relays PNOZsigma PNOZ s50

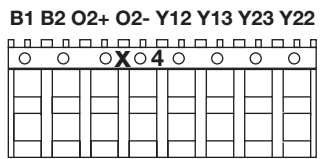
| Female connector X4 | Terminal | Description |
|---|----------|--|
|  | B1 | Supply voltage of power circuits |
| | B2 | Reference potential of the supply voltage to the power circuits |
| | O2+ | Failsafe output for power circuit 2, positive |
| | O2- | Failsafe output for power circuit 2, negative |
| | Y12 | Reference potential for failsafe inputs for fast shutdown, power circuit 1 |
| | Y13 | Reference potential for failsafe inputs for fast shutdown, power circuit 1 |
| | Y23 | Reference potential for failsafe inputs for fast shutdown, power circuit 2 |
| | Y22 | Reference potential for failsafe inputs for fast shutdown, power circuit 2 |

Supply voltage for device

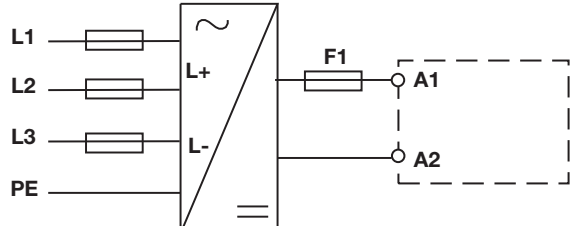
| | |
|--|--|
| Supply voltage to the device |  |
| <p>Please note: The supply voltage must be protected with a fuse.</p> <p>Fuse F1: Circuit breaker, 24 VDC, 4 A, characteristic B/C</p> | |

Requirements:

- ▶ When selecting the power supply, please refer to the requirements stated under [Technical details](#) [[934](#)].
- Make sure that the supply voltage for the device (A1/A2) complies with the specified tolerance of -15/+20 %. If the voltage is outside this tolerance, then
- the device will change to a fault condition, if the outputs are switched on.
 - a message will be entered in the error stack if the outputs are switched off.

Safety relays PNOZsigma PNOZ s50

Supply voltage for power circuits

Requirements:

- ▶ When selecting the power supply, please refer to the requirements stated under [Technical details](#) [934].

Make sure that the supply voltage for the power circuits (B1/B2) complies with the specified tolerance of +/- 10 %. If the voltage is outside this tolerance, then

- the device will change to a fault condition, if the outputs are switched on.
- a message will be entered in the error stack if the outputs are switched off.

- ▶ The power supply must be able to bridge a power outage of 20 ms.

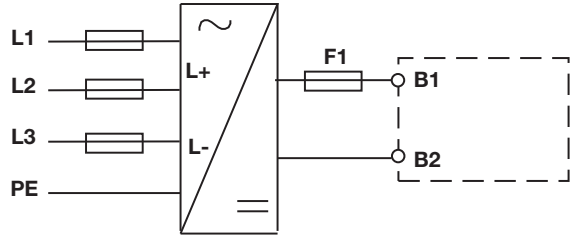
| | |
|---|---|
| Supply voltage for power circuits | |
| <p>Please note: The supply voltage must be protected with a fuse.</p> <p>Fuse F1: Circuit breaker 24 V, 48 VDC, 10 A, characteristic B/ C</p> |  |

Power circuit

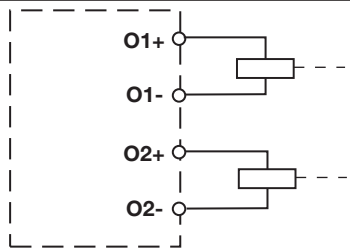
| | |
|-------------------|--|
| Power circuit | |
| Dual-pole outputs |  |

Safety relays PNOZsigma PNOZ s50

Inputs

Fast shutdown

| | |
|--|--|
| <p>Activation via safe single-pole outputs</p> | |
| <p>Link Y12 – Y13 Link Y22 – Y23</p> <p>PLC: Safety control system</p> | |
| <p>Activation via safe dual-pole outputs</p> | |
| <p>Link Y10 – Y11 Link Y20 – Y21</p> <p>PLC: Safety control system</p> | |

Safety relays PNOZsigma PNOZ s50

Slow shutdown

| | |
|--|--|
| Activation via single-pole outputs | |
| PLC: Safety control system | |
| Connect the inputs to 24 VDC if slow shutdown is not being used. S11: Voltage output 24 VDC | |

Outputs

| | |
|----------------------------|--|
| Status outputs | |
| PLC: Safety control system | |

Feedback loop

| | |
|---|--|
| Feedback loop | |
| A N/C contact is shown in the connection diagram. A N/O contact can also be configured. | |
| Feedback loop with test pulses | |
| Please note the allocation of the test pulses and feedback loops: T0 <-> Y1 T1 <-> Y2 | |

Safety relays PNOZsigma PNOZ s50

Display menu and configuration

The menu settings are made on the unit's display via a rotary knob. You have the option to make the settings on the knob by hand or with a screwdriver. If you make the settings with a screwdriver, the knob can remain within the unit.

Operate rotary knob

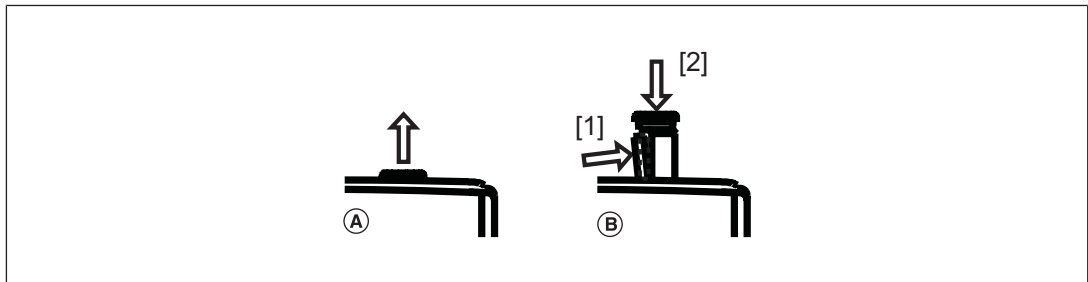

Pull out knob (A):

- ▶ until it locks into position
- ▶ Release knob (B) and push it back into the unit:
 - Press the bar on the side of the knob [1] towards the centre of the knob. This releases the knob.
 - Press the knob downwards [2] while keeping the bar pressed in

Configure device

The settings are made via the rotary knob, as follows:

Press the knob

- ▶ Confirm selection/setting
- ▶ Switch to menu

Rotate knob

- ▶ Select menu level
- ▶ Set the parameter/numeric value

The display is backlit. It is

- ▶ switched on by turning or pressing the rotary knob.
- ▶ switched off if the rotary knob has not been operated for 30 seconds.

Password protection

The configuration is password-protected.

- ▶ Parameters can only be changed once a password has been entered.
- ▶ Factory setting for the password: 000000
- ▶ The password consists of 6 figures in the range 000000 ... 999999.
- ▶ The password can be changed at any time in the menu.



Safety relays PNOZsigma PNOZ s50

Use chip card

The parameters that are set on a device are stored on the chip card. The data is stored along with a device identifier and check sum. We recommend that you always operate the unit with a chip card.

When the chip card is inside the unit,

- ▶ The chip card is checked to verify the device identifier, valid parameters, and ensure that the data is identical.
- ▶ Device parameters are automatically saved to the chip card during configuration. As a result, the chip card always contains a copy of the unit's current internal data.

When the device is switched on in the Power On operating state (all LEDs illuminate briefly) a test is carried out to check whether

- ▶ a chip card is inserted or just an empty chip card holder.
- ▶ data on the chip card matches the data in the device.
- ▶ data on the chip card is valid.

In the Configuration operating state ("Run" LED flashes):

- ▶ The data is written to the chip card during configuration.

In the RUN operating state ("Run" LED is lit):

- ▶ The chip card containing a valid configuration must be inserted.
- ▶ The chip card must not be removed during operation.

Insert chip card

Make sure that you do not bend the chip card as you insert it into the chip card slot.

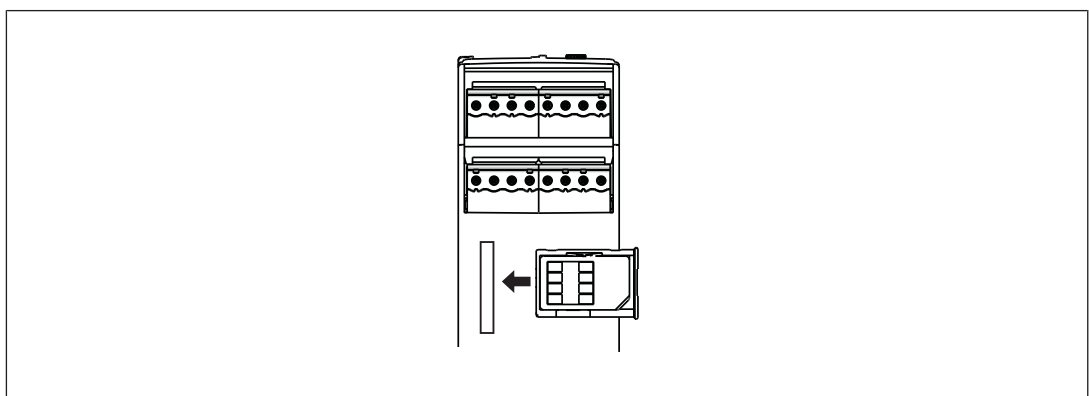

Save configuration with Software SmartCardCommander

You have the option to save a PNOZ s50 configuration from the chip card to your computer. The configuration can be saved on the computer and then downloaded to other chip cards.

To do this you will need the chip card reader **PNOZ Chip Card Reader** with the corresponding **SmartCardCommander** software. Both are available from Pilz as accessories, individually or as part of a set (see [Order references Accessories](#) [ 939]).

Safety relays PNOZsigma PNOZ s50

Save PNOZ s50 configuration on the computer

1. Make a note of the configuration's CRC in the PNOZ s50. It is shown on the display in the **Information/ Configuration CRC** menu. This will be needed later to check whether the correct configuration is saved on the device.
2. Remove the chip card from the PNOZ s50 and insert it into the holder for the chip card reader.
3. Start the **SmartCardCommander** software.
4. Insert the holder containing the chip card into the chip card reader.
5. The **Memory Card** directory is displayed in a list under **Hardware** on the software interface of the **SmartCardCommander**.

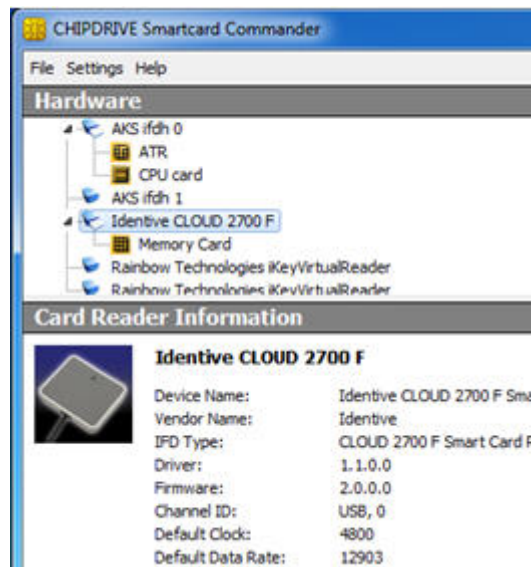

6. To read the data on the chip card, click on the **Memory Card** directory and then select **Read Data from Card**.
7. When **Data read successfully** is displayed on the software interface, the data can be saved as a hex file in any directory on the computer.
8. Make sure that the corresponding configuration CRC, which you noted down, is saved in the same directory.

Download configuration from the computer to the PNOZ s50

1. Insert a chip card into the holder for the chip card reader and insert this into the chip card reader.
2. Start the **SmartCardCommander** software.
3. To write the chip card, select **Write Data to Card** and confirm with **Yes**.
4. Insert the chip card in the PNOZ s50.

Safety relays PNOZsigma PNOZ s50

5. To ensure that the configuration has been transferred correctly, check that the CRC for the configuration in the PNOZ s50 matches the configuration CRC you noted down on the computer.

Display and configuration



Menu overview

The following diagrams illustrate the principle structure of the configuration menu on the display.

The menu consists of

- ▶ Messages at cold start, if there are problems with the chip card.
- ▶ Level 1: Status indicators, error stack
- ▶ Level 2: Password entry
- ▶ Level 3: Configuration



The displayed symbols illustrate the operation of the rotary knob.

| | |
|---|-------------|
|  | Rotate knob |
|  | Press knob |

Level 1 and 2: Status indicators and password entry

Status information is displayed when the device is switched on. This level is not password-protected.

The state of the signals is displayed as follows:

| Icon | Description |
|---|-----------------|
|  | Signal inactive |
|  | Signal active |

The password is entered in Level 2. It authorises configuration of the device in Level 3.

Safety relays PNOZsigma PNOZ s50

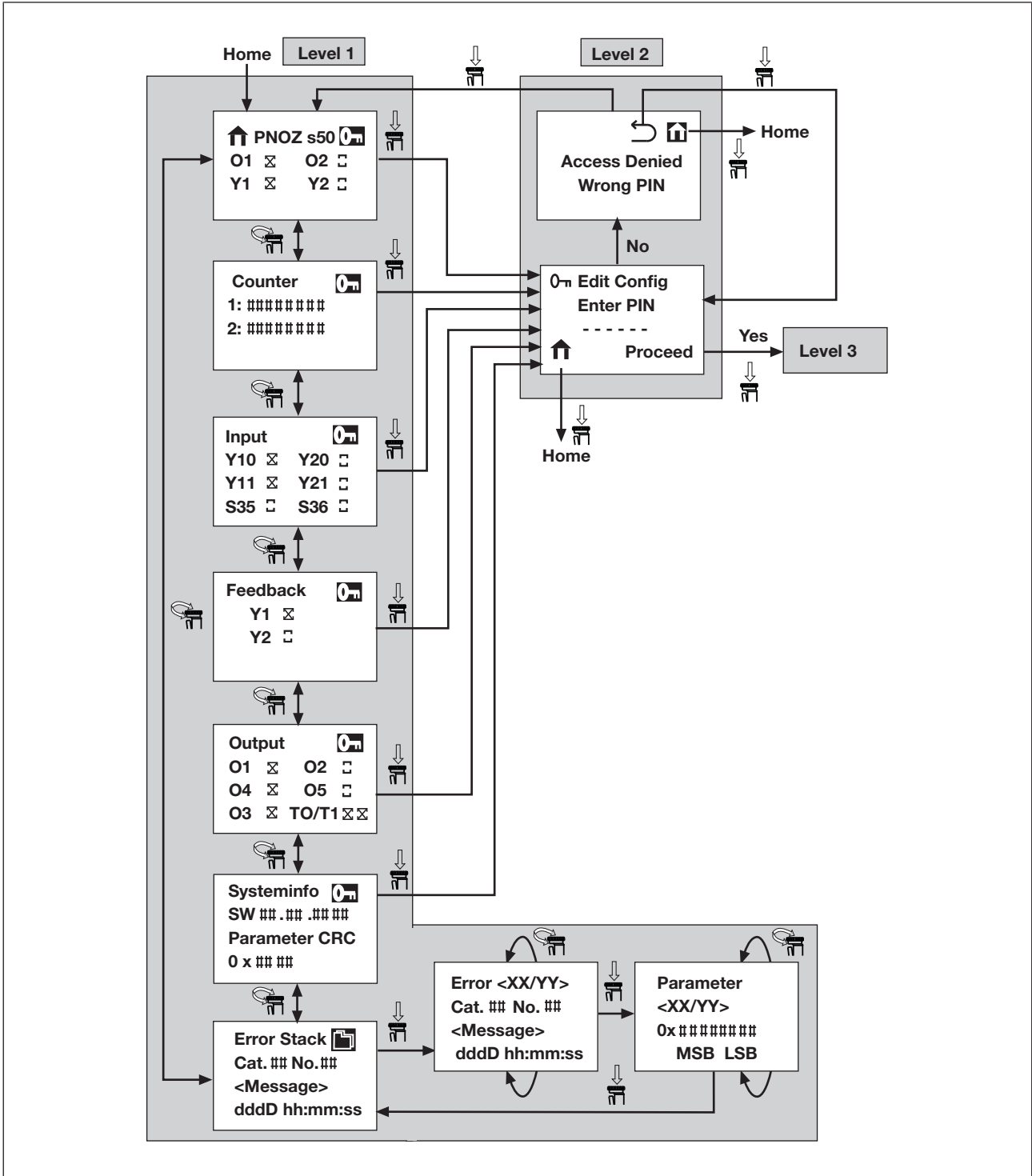

Fig.: Menu overview of Levels 1 and 2

Safety relays PNOZsigma PNOZ s50

Level 3: Configuration

The device is configured in Level 3.

Safety relays PNOZsigma PNOZ s50

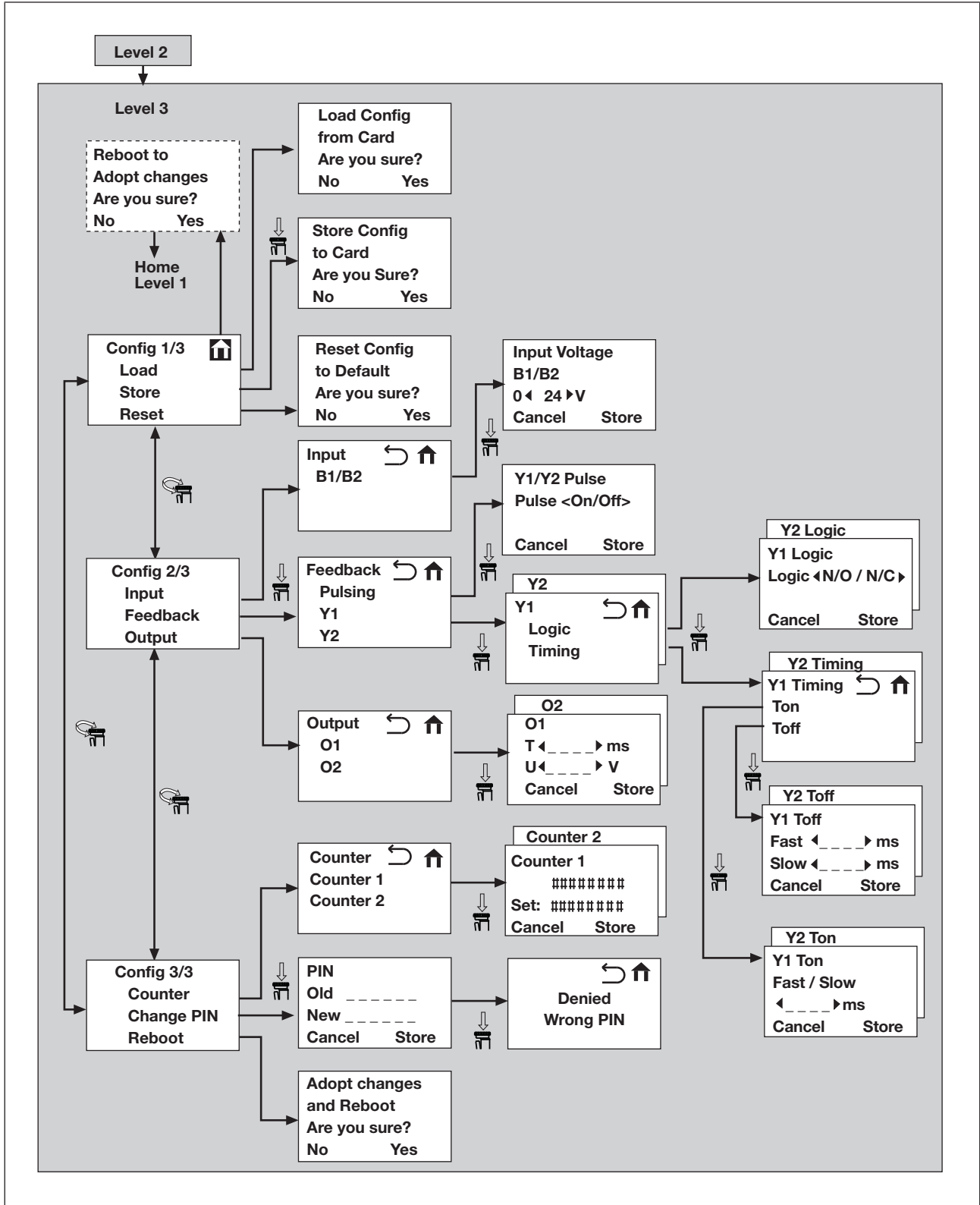

Fig.: Menu overview of Level 3

Safety relays PNOZsigma PNOZ s50

Operate menus and enter values

Various navigational aids are available on the display:

- ▶ Tags
- ▶ Text fields

Tags

| Display | Description |
|---------|--|
| ↶ | Returns to the previous menu |
| ⬆ | Exits the configuration menu (Level 3) and switches to the home menu (Level 1) |
| 📄 | Switches from the current error in the error stack |
| 🔑 | Switches to the password menu (Level 2) |

Text fields

| Text field | Description |
|---------------------|---|
| Cancel or No | Rejects all the changes and returns to the previous menu |
| Proceed | Confirms the password entry and jumps to the configuration menu (Level 3) |
| Store or Yes | Saves all the changes and returns to the previous menu |

To move within a menu and switch to another menu, proceed as follows:

1. Turn the rotary knob to jump from line to line.
The position within the menu is highlighted.
2. Press the rotary knob to move to the next menu or to the previous menu.

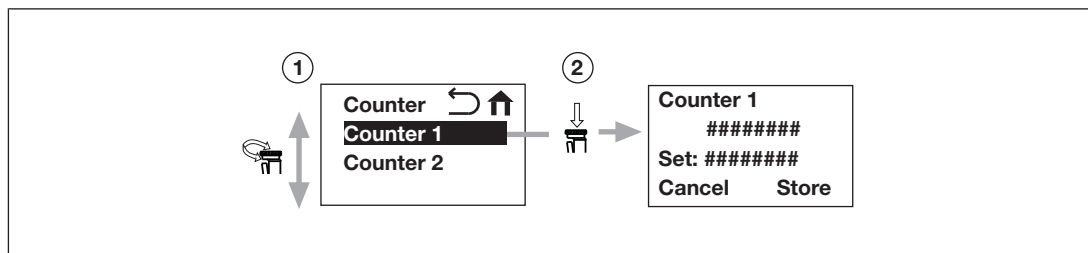

Fig.: Moving from line to line

To change values in a menu, follow the instructions below:

1. Turn the rotary knob to jump from line to line.
2. Press the rotary knob. Only then is it possible to change a numeric value.
The selected area flashes. Values can now be changed.
3. Turn the rotary knob to switch between numeric values.
4. Press the rotary knob to complete the entry.

Safety relays PNOZsigma PNOZ s50

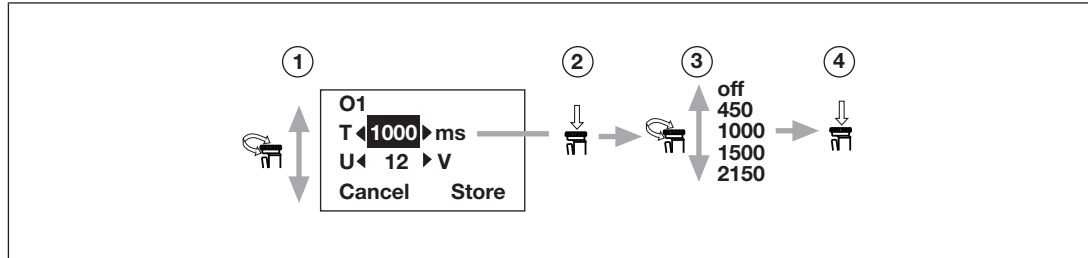

Fig.: Changing numeric values

Display menu at cold start

When the device is switched on in the Power On operating state (cold start), the memory contents of the device and the chip card are read and compared. If there are any deviations, messages will appear.

| Overview | Display | Description |
|--|--|---|
| No Chipcard detected No chip card and no chip card holder in the device. | <div style="border: 1px solid black; padding: 5px; width: fit-content; margin: auto;"> No Cipcard detected Proceed? No Yes </div> | No – Insert chip card or only chip card holder Yes – Switch to RUN operating state, without a chip card inserted |
| Chipcard is Defect The chip card is defective or Only the chip card holder is inserted. | <div style="border: 1px solid black; padding: 5px; width: fit-content; margin: auto;"> Cipcard is defect, remove Or replace Proceed </div> | Proceed – 1. Use a valid chip card or insert chip card holder only. 2. Restart device with Proceed . |
| Memories are unequal The parameters on the chip card and in the device memory are not identical. | <div style="border: 1px solid black; padding: 10px; margin: auto;"> <div style="display: flex; justify-content: space-between;"> <div style="border: 1px solid black; padding: 5px; width: 30%;"> Memories are unequal, Copy Ext. To Int. ? Int. To Ext. ? </div> <div style="border: 1px solid black; padding: 5px; width: 30%;"> Copy from Ext. Memory and Restart? No Yes </div> <div style="border: 1px solid black; padding: 5px; width: 30%;"> Copy from Int. Memory and Restart? No Yes </div> </div> </div> | |







Safety relays PNOZsigma PNOZ s50

| Overview | Display | Description |
|--|--|---|
| | <div style="border: 1px solid black; padding: 5px; width: fit-content; margin: auto;"> Memories are unequal, Copy Ext. To Int. ? Int. To Ext. ? </div> | <p>Ext. To Int. – Switch to the next menu to download parameters from the chip card to the device memory</p> <p>Int. To Ext. – Switch to the next menu to upload parameters from the device memory to the chip card</p> |
| | <div style="border: 1px solid black; padding: 5px; width: fit-content; margin: auto;"> Copy from Ext. Memory and Restart? No Yes </div> | <p>No – Return to the previous menu</p> <p>Yes – Download parameters from the chip card to the device memory</p> |
| | <div style="border: 1px solid black; padding: 5px; width: fit-content; margin: auto;"> Copy from Int. Memory and Restart? No Yes </div> | <p>No – Return to the previous menu</p> <p>Yes – Upload parameters from the device memory to the chip card</p> |
| <p>Chipcard is Invalid The parameters on the chip card are invalid.</p> | <div style="border: 1px solid black; padding: 5px; width: fit-content; margin: auto;"> Cipcard is Invalid, Copy Int. to Ext.? No Yes </div> | <p>No – 1. Use a valid chip card or insert chip card holder only. 2. Restart device with No.</p> <p>Yes – Upload parameters from the device memory to the chip card</p> |

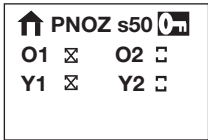
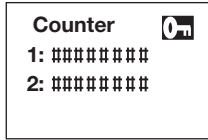
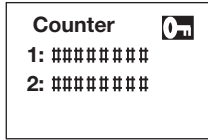
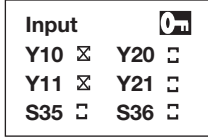
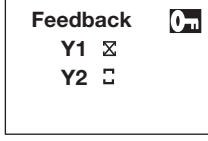

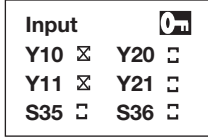

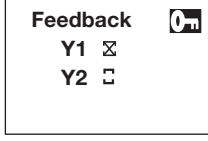



Safety relays PNOZsigma PNOZ s50

Status display and configuration

Level 1: Status indicators

| Overview | Display | Description |
|---|--|--|
| PNOZ s50 C Start-up display |  <p>↑ PNOZ s50  O1 ☒ O2 ☐ Y1 ☒ Y2 ☐</p> | PNOZ s50 – Device name O1, O2 – Outputs of the power circuits O1 and O2 Y1, Y2 – Standard inputs of feedback loops 1 and 2. |
| Counter Number of operations |  <p>Counter  1: ##### 2: #####</p> | 1: Counter for output O1+/ O1- 2: Counter for output O2+/ O2- |
| Systeminfo |  <p>Systeminfo  SW ##.##.## Parameter CRC 0 x ##</p> | SW: Software version of device, e.g. 01.01.0001 Parameter CRC: Check sum covering the device configuration |
| Input States of the inputs are displayed |  <p>Input  Y10 ☒ Y20 ☐ Y11 ☒ Y21 ☐ S35 ☐ S36 ☐</p> | Y10 – Failsafe input 0 for fast shutdown, power circuit 1 Y11 – Failsafe input 1 for fast shutdown, power circuit 1 Y20 – Failsafe input 0 for fast shutdown, power circuit 2 Y21 – Failsafe input 1 for fast shutdown, power circuit 2 S35 – Standard input for slow shutdown, power circuit 1 S36 – Standard input for slow shutdown, power circuit 2 |
| Feedback States of the feedback loops are displayed |  <p>Feedback  Y1 ☒ Y2 ☐</p> | Y1 – Standard input for feedback loop 1 Y2 – Standard input for feedback loop 2 |

Safety relays PNOZsigma PNOZ s50

| Overview | Display | Description |
|---|--|---|
| <p>Output</p> <p>States of the outputs are displayed</p> | <div style="border: 1px solid black; padding: 5px; width: fit-content;"> <p>Output </p> <p>O1  O2 </p> <p>O4  O5 </p> <p>O3  TO/T1  </p> </div> | <p>O1 – Failsafe output for power circuit 1</p> <p>O2 – Failsafe output for power circuit 2</p> <p>O3 – Failsafe output for fault signal</p> <p>O4 – Failsafe output for status of power circuit 1</p> <p>O5 – Failsafe output for status of power circuit 1</p> <p>TO/T1 – Test pulse output 0/1</p> |

Safety relays PNOZsigma PNOZ s50

| Overview | Display | Description |
|--|---|---|
| Error Stack Error messages are displayed | <div style="border: 1px solid black; padding: 5px; width: fit-content;"> Error Stack  Cat. ### No. ### <Message> dddD hh:mm:ss </div> | Current error stack entry Cat. – Error class (hexadecimal) No. – Error number (hexadecimal) <Message> – Error text dddD hh:mm:ss – Power-on time since Power On: Days, hours, minutes, seconds |
| | <div style="border: 1px solid black; padding: 5px; width: fit-content;"> Error <XX/YY> Cat. ## No. ## <Message> dddD hh:mm:ss </div> | Error stack entries <XX/YY> – Entry number/number of entries (decimal) Cat. – Error class (hexadecimal) No. – Error number (hexadecimal) <Message> – Error text dddD hh:mm:ss – Power-on time since error occurred: Days, hours, minutes, seconds |
| | <div style="border: 1px solid black; padding: 5px; width: fit-content;"> Parameter <XX/YY> 0x##### MSB LSB </div> | Parameters of a selected entry in the error stack <XX/YY> – Current parameter/number of available parameters (decimal) 0x##### – Parameters (hexadecimal), grouped by MSB and LSB |

Safety relays PNOZsigma PNOZ s50

Level 2: Password entry

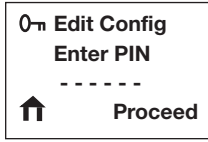
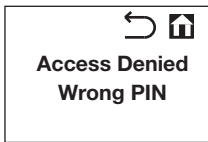
| Overview | Display | Description |
|------------------------------|--|--|
| PIN Password entry |  | ----- – Field for entering the password Proceed – Confirm entry and jump to Level 3 Home – To start menu, without confirming entry |
| |  | You entered an incorrect password. Back – Back to password entry Home – Back to start menu |

Level 3: Configuration

The device is supplied with the following parameters:

| Function | Terminal | Description | Parameter | Value | In display menu |
|--|----------|---|---------------|---|--|
| Supply voltage, power circuits 1 and 2 | B1/B2 | Supply voltage | Input Voltage | 24 V | Input -> Input Voltage |
| Test pulses | Y1/Y2 | Test pulses on feedback loops | Pulsing | On | Feedback -> Pulsing -> Y1/Y2 Pulse |
| Power circuit 1 | O1+/O1- | Reduced voltage | U | 6 V | Output -> O1 |
| | | Overexcitation time | T | 100 ms | Output -> O1 |
| | Y1 | Maximum ventilation time | Ton | 30 ms | Feedback -> Y1 -> Y1 Timing -> Y1 Ton |
| | | Maximum application time, fast shutdown | Toff fast | 30 ms | Feedback -> Y1 -> Y1 Timing -> Y1 Toff |
| | | Maximum application time, slow shutdown | Toff slow | 30 ms | Feedback -> Y1 -> Y1 Timing -> Y1 Toff |
| Logic of feedback loop 1 | Logic | N/C | | Feedback -> Y1 -> Logic -> Y1 Logic | |

Safety relays PNOZsigma PNOZ s50

| Function | Terminal | Description | Parameter | Value | In display menu |
|--------------------------|----------|---|---|--------|--|
| Power circuit 2 | O2+/O2- | Reduced voltage | U | 6 V | Output -> O2 |
| | | Overexcitation time | T | 100 ms | Output -> O2 |
| | Y2 | Maximum ventilation time | Ton | 30 ms | Feedback -> Y2 -> Y1 Timing -> Y2 Ton |
| | | Maximum application time, fast shutdown | Toff fast | 30 ms | Feedback -> Y2 -> Y1 Timing -> Y2 Toff |
| | | Maximum application time, slow shutdown | Toff slow | 30 ms | Feedback -> Y2 -> Y1 Timing -> Y2 Toff |
| Logic of feedback loop 2 | Logic | NC | Feedback -> Y2 -> Logic -> Y2 Logic | | |

| Overview | Display | Description |
|---------------------------|--|--|
| Switch to submenus | | |
| Config 1/3 | <div style="border: 1px solid black; padding: 5px; width: fit-content;"> Config 1/3  Load Store Reset </div> | <p>Load – Switches to the Load menu to download the configuration from the chip card</p> <p>Store – Switches to the Store menu to save the configuration to the chip card</p> <p>Reset – Switches to the Reset menu to reset the configuration to the default settings</p> |
| Config 2/3 | <div style="border: 1px solid black; padding: 5px; width: fit-content;"> Config 2/3 Input Feedback Output </div> | <p>Input – Switches to the Input menu to configure the supply voltage for the power element</p> <p>Feedback – Switches to the Feedback menu to configure the feedback loops</p> <p>Output – Switches to the Output menu to configure the properties of the power outputs O1+/O1- and O2+/O2-</p> |
| Config 3/3 | <div style="border: 1px solid black; padding: 5px; width: fit-content;"> Config 3/3 Counter Change PIN Reboot </div> | <p>Counter – Switches to the Counter menu to enter a start value for the counter</p> <p>Change PIN – Switches to the Change PIN menu to change the password</p> <p>Reboot – Switches to the Reboot menu to restart the device</p> |

Safety relays PNOZsigma PNOZ s50

| Overview | Display | Description |
|--|---|--|
| Load configuration from chip card | | |
| Load Config from Card Download parameters from the chip card to the device | <div style="border: 1px solid black; padding: 5px; width: fit-content; margin: auto;"> Load Config from Card Are you sure? No Yes </div> | Are you sure? – Security prompt No – Do not download parameters from chip card Yes – Download parameters from chip card |
| Save configuration to chip card | | |
| Store Config to Card Download parameters from the device to the chip card | <div style="border: 1px solid black; padding: 5px; width: fit-content; margin: auto;"> Store Config to Card Are you Sure? No Yes </div> | Are you sure? - Security prompt No – Do not save parameters to chip card Yes – Save parameters to chip card |
| Restore default settings | | |
| Reset Config to Default Reset configuration to default settings | <div style="border: 1px solid black; padding: 5px; width: fit-content; margin: auto;"> Reset Config to Default Are you sure? No Yes </div> | Are you sure? – Security prompt No – Do not load default settings Yes – Load default settings |
| Configure supply voltage B1/B2 to the power circuits | | |
| Input Switch to the menu for the supply voltage to the power circuits | <div style="border: 1px solid black; padding: 5px; width: fit-content; margin: auto;"> Input B1/B2 </div> | B1/B2 – Switch to the Input Voltage menu to configure the inputs B1/B2 |
| Input Voltage Configure the supply voltage to the power circuits | <div style="border: 1px solid black; padding: 5px; width: fit-content; margin: auto;"> Input Voltage B1/B2 U < 24 > V Cancel Store </div> | U < 24 > V – Select supply voltage for power circuit, values: 24 V, 48 V Cancel – Exit menu without confirming the entry Store – Confirm entry |
| Configure feedback loops Y1 and Y2 | | |
| Feedback Configure feedback loops | <div style="border: 1px solid black; padding: 5px; width: fit-content; margin: auto;"> Feedback Pulsing Y1 Y2 </div> | Pulsing – Configure test pulses Y1 – Switch to the Y1 menu to configure feedback loop Y1 Y2 – Switch to the Y2 menu to configure feedback loop Y2 |

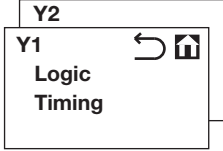
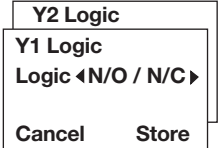
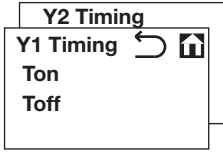
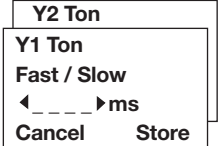

Safety relays PNOZsigma PNOZ s50

| Overview | Display | Description |
|---|---|--|
| Y1/Y2 Pulse Activate test pulse |  | Pulse On: Test pulse on Pulse Off: Test pulse off Cancel – Exit menu without confirming the entry Store – Confirm entry Please note: The test pulses can only be activated simultaneously for both feedback loops Y1 and Y2. |
| Y1 or Y2 Switch to sub-menus for configuration of the feedback loops |  | Logic – Switch to Logic Y1 or Logic Y2 menu Timing – Switch to Timing Y1 or Timing Y2 menu |
| Y1 Logic or Y2 Logic Define N/C or N/O contact in the feedback loop |  | Logic < N/O /N/C > - Input logic for feedback loop Y1 or Y2: N/O: N/O contact N/C: N/C contact Cancel – Exit menu without confirming the entry Store – Confirm entry |
| Y1 Timing or Y2 Timing |  | Ton – Switch to submenu for configuration of the max. ventilation time Toff – Switch to submenu for configuration of the max. application time |
| Y1 Ton or Y2 Ton Configure max. ventilation time for fast and slow shutdown |  | Slow / Fast < 500 > ms – Max. ventilation time Values: 30 ... 4000 ms configurable in steps The max. ventilation times are the same for fast and slow shutdown. Cancel – Exit menu without confirming the entry Store – Confirm entry |

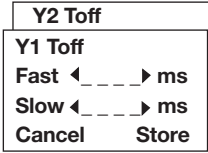
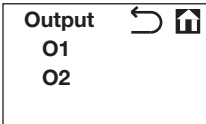
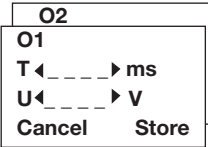
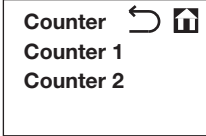
Safety relays PNOZsigma PNOZ s50

| Overview | Display | Description |
|--|---|--|
| <p>Y1 Toff or Y2 Toff</p> <p>Configure max. application time for fast and slow shutdown</p> |  | <p>Fast < 500 > ms – Max. application time for fast shutdown</p> <p>Slow < 500 > ms – Max. application time for slow shutdown</p> <p>Values: 30 ... 4000 ms configurable in steps</p> <p>Cancel – Exit menu without confirming the entry</p> <p>Store – Confirm entry</p> |
| <p>Configure power circuits O1+/O1- and O2+/O2-</p> | | |
| <p>Output</p> <p>Configure power circuits</p> |  | <p>O1 – Switch to the O1 menu to configure power circuit 1</p> <p>O2 – Switch to the O2 menu to configure power circuit 2</p> |
| <p>O1 or O2</p> <p>Configure overexcitation time and reduced voltage</p> |  | <p>O1 or O2</p> <p>T < 1000 > ms – Configure overexcitation time, values: off, 100 ... 2500 ms configurable in steps.</p> <p>If "off" is configured, the voltage at B1/B2 is connected directly to outputs O1 or O2 without reduction. Any value entered for the reduced voltage will not be evaluated.</p> <p>U < 12 > V – Configure reduced voltage, values: 6, 8, 12, 16, 24 V</p> <p>Store – Confirm entry</p> <p>Cancel – Exit menu without confirming the entry</p> |
| <p>Configure counter</p> | | |
| <p>Counter</p> <p>Specify offset for number of operations</p> |  | <p>Counter 1 – Event counter 1 - Switch to the Counter 1 menu to configure the number of operations for power circuit O1+/O1-</p> <p>Counter 2 – Event counter 2 - Switch to the Counter 2 menu to configure the number of operations for power circuit O2+/O2-</p> |

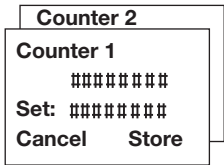
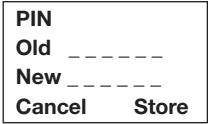
Safety relays PNOZsigma PNOZ s50

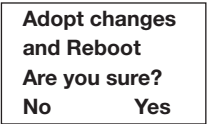
| Overview | Display | Description |
|--|---|--|
| <p>Counter 1 or Counter 2</p> <p>Switch to menu to set the counter for the number of operations for power circuits O1+/O1- or O2+/O2-</p> |  | <p>Counter 1 – Event counter 1 - Configure number of operations for load at power circuit O1+/O1-</p> <p>Counter 2 – Event counter 2 - Configure number of operations for load at power circuit O2+/O2-</p> <p>##### – Old counter status</p> <p>Set: – Enter new counter status, e.g. when a used load is applied Value range: 0 ... 99999999</p> <p>Store – Confirm entry</p> <p>Cancel – Exit menu without confirming the entry</p> |
| Change password | | |
| <p>PIN</p> <p>Change password</p> |  | <p>Old – Enter the old password</p> <p>New – Enter the new password</p> <p>Cancel – Exit menu without confirming the entry</p> <p>Store – Adopt new password</p> |
| <p>Denied Wrong PIN</p> <p>Error message</p> |  | <p>You entered an incorrect password</p> |
| Restart after changing configuration | | |
| <p>Adopt changes and Reboot</p> <p>Restart and adopt configuration</p> |  | <p>No – Do not restart</p> <p>Yes – Restart</p> |

Restart device

Restart the device if you have changed the configuration. The changed configuration is adopted during a restart.

There are two options for restarting the device once the configuration is complete.

Option one:

1. Switch off the device's supply voltage (terminals A1 and A2).
2. Switch the device's supply voltage back on.

The configuration is adopted.

Safety relays PNOZsigma PNOZ s50

Option two:

1. Select **Reboot** in menu level 3.
2. Select **Yes** and press the rotary knob.

The device is restarted and the configuration is adopted.

Examples

Overview

This chapter provides information on how to connect the PNOZ s50 to a safety control system. The connections illustrated are independent of any specific control system.

Mechanical holding brake

Properties

PNOZ s50

- ▶ Safe activation of two independent mechanical holding brakes
- ▶ Ventilation and application times are monitored
- ▶ Fast and slow shutdown of both brakes
- ▶ Feedback loop for brake B1 is monitored via input Y1
- ▶ Feedback loop for brake B2 is monitored via input Y2
- ▶ Fuses
 - F1: 24 V DC, 4 A, characteristic B/C
 - F2: 24 V DC, 10 A, characteristic B/C

Safety control system

- ▶ Inputs:
 - Fault signal O3
 - State of brakes O4, O5 (applied, ventilated) is monitored
- ▶ Outputs
 - Activation of fast and slow shutdown of brake

Brake

- ▶ Micro switch S1 to signal the state of brake B1
- ▶ Micro switch S2 to signal the state of brake B2

Safety relays PNOZsigma PNOZ s50

Configuration overview

The following parameters must be set in the display menu:

| Function | Terminal | Description | Parameter | Value | In display menu |
|--|----------|---|---|--------|--|
| Supply voltage, power circuits 1 and 2 | B1/B2 | Supply voltage | Input Voltage | 24 V | Input -> Input Voltage |
| Test pulse | Y1/Y2 | Test pulses on feedback loops | Pulsing | On | Feedback -> Pulsing -> Y1/Y2 Pulse |
| Power circuit 1 | O1+/O1- | Reduced voltage | U | 12 V | Output -> O1 |
| | | Overexcitation time | T | 450 ms | Output -> O1 |
| | Y1 | Maximum ventilation time | Ton | 60 ms | Feedback -> Y1 -> Y1 Timing -> Y1 Ton |
| | | Maximum application time, fast shutdown | Toff fast | 30 ms | Feedback -> Y1 -> Y1 Timing -> Y1 Toff |
| | | Maximum application time, slow shutdown | Toff slow | 150 ms | Feedback -> Y1 -> Y1 Timing -> Y1 Toff |
| Logic of feedback loop 1 | Logic | N/C | Feedback -> Y1 -> Logic -> Y1 Logic | | |
| Power circuit 2 | O2+/O2- | Reduced voltage | U | 12 V | Output -> O2 |
| | | Overexcitation time | T | 450 ms | Output -> O2 |
| | Y2 | Maximum ventilation time | Ton | 60 ms | Feedback -> Y2 -> Y1 Timing -> Y2 Ton |
| | | Maximum application time, fast shutdown | Toff fast | 30 ms | Feedback -> Y2 -> Y1 Timing -> Y2 Toff |
| | | Maximum application time, slow shutdown | Toff slow | 150 ms | Feedback -> Y2 -> Y1 Timing -> Y2 Toff |
| Logic of feedback loop 2 | Logic | NC | Feedback -> Y2 -> Logic -> Y2 Logic | | |

Safety relays PNOZsigma PNOZ s50

Connection

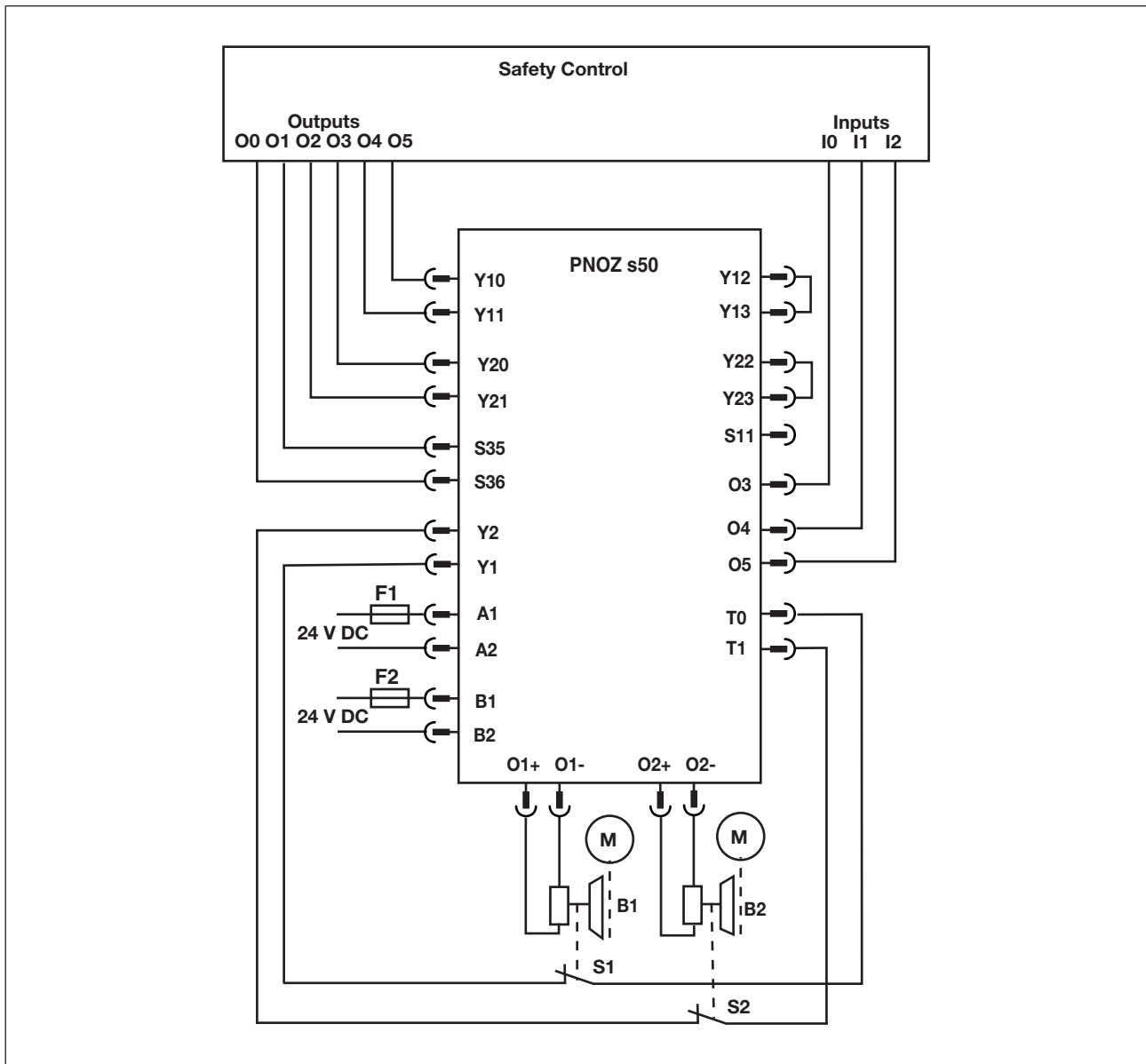

Fig.: Connection example: Two mechanical holding brakes

Safety relays PNOZsigma PNOZ s50

Technical details

| General | |
|---|--|
| Approvals | CE, EAC (Eurasian), TÜV, cULus Listed |
| Electrical data | |
| Supply voltage | |
| for | Supply to the system |
| Voltage | 24 V |
| Kind | DC |
| Voltage tolerance | -15 %/+20 % |
| Output of external power supply (DC) | 18 W |
| Output of external power supply (DC) at no load | 3 W |
| Residual ripple DC | 5 % |
| External unit fuse protection F1 | 4 A, circuit breaker 24 V DC, characteristic B/C |
| Potential isolation | No |
| Supply voltage | |
| for | Supply to 2-pole SC outputs |
| Voltage | 24 V, 48 V |
| Kind | DC |
| Voltage tolerance | -10 %/+10 % |
| Output of external power supply (DC) | 240 W |
| External unit fuse protection F1 | 10 A, circuit breaker 48 V DC, characteristic B/C |
| Potential isolation | yes |
| Inputs | |
| Number | 8 |
| Number of safe inputs | 4 |
| Number of standard inputs | 4 |
| Input current, safe inputs | 3 - 10 mA |
| Input current, standard inputs | 3 - 10 mA |
| Min. threshold voltage when signal changes from "1" to "0", safe inputs | 7 V |
| Max. threshold voltage when signal changes from "0" to "1", safe inputs | 10 V |
| Min. threshold voltage when signal changes from "1" to "0", standard inputs | 7 V |
| Max. threshold voltage when signal changes from "0" to "1", standard inputs | 10 V |
| Pulse suppression | 1 ms |
| Voltage at | |
| Input circuit DC | 24 V |
| Feedback loop DC | 24 V |
| Potential isolation | No |

Safety relays PNOZsigma PNOZ s50

| Semiconductor outputs | |
|--|---|
| Number of positive-switching single-pole semiconductor outputs | 3 |
| Switching capability | |
| Voltage | 24 V |
| Current | 0,1 A |
| Max. duration of off time during self test | 300 µs |
| Short circuit-proof | yes |
| Potential isolation | No |
| Permitted loads | inductive, capacitive, resistive |
| Semiconductor outputs, 2-pole | |
| Number of dual-pole semiconductor outputs | 2 |
| Maximum output power during continuous duty | 84 W |
| Maximum output power during overexcitation | 156 W |
| Reduced voltages | 6 V, 8 V, 12 V, 16 V, 24 V |
| Voltage tolerance of reduced voltages | -10 %/+10 % |
| Max. output current at "1" signal, 24 V, continuous duty | 3,5 A |
| Max. output current at "1" signal, 48 V, continuous duty | 1,75 A |
| Max. output current at "1" signal, 24 V, overexcitation | 6,5 A |
| Max. output current at "1" signal, 48 V, overexcitation | 3,25 A |
| Min. current at 2-pole output at "1" signal | 100 mA |
| Short circuit-proof | yes |
| Permitted loads | Inductive |
| Max. duration of off time during self test | 500 µs |
| Voltage outputs | |
| Number | 1 |
| Voltage | 24 V DC |
| Max. current | 0,1 A |
| Short circuit-proof | yes |
| Potential isolation | No |
| Test pulse outputs | |
| Number of test pulse outputs | 2 |
| Voltage, test pulse outputs | 24 V DC |
| Max. duration of off time during self test | 6 ms |
| Short circuit-proof | yes |
| Max. output current at "1" signal | 0,1 A |
| Potential isolation | No |
| Times | |
| Supply interruption before de-energisation | 20 ms |
| Max. reaction time when the input signal changes | 7 ms |

Safety relays PNOZsigma PNOZ s50

| Times | |
|---|--|
| Ventilation time configurable in steps | 30 ms ... 4000 ms |
| Application time during fast shutdown configurable in steps | 30 ms ... 4000 ms |
| Application time during slow shutdown configurable in steps | 30 ms ... 4000 ms |
| Overexcitation time configurable in steps | 100 ms ... 2500 ms |
| Environmental data | |
| Climatic suitability | EN 60068-2-1, EN 60068-2-14, EN 60068-2-2, EN 60068-2-78 |
| Ambient temperature | |
| Temperature range | 0 - 55 °C |
| Storage temperature | |
| Temperature range | -40 - 85 °C |
| Climatic suitability | |
| Humidity | 93 % r. h. at 40 °C |
| Condensation during operation | Not permitted |
| EMC | EN 61000-4-2, EN 61000-4-3, EN 61000-4-4, EN 61000-4-5, EN 61000-4-6, EN 61000-4-8, EN 61326-3-1 |
| Vibration | |
| In accordance with the standard | EN 60068-2-6 |
| Frequency | 10 - 55 Hz |
| Amplitude | 0,35 mm |
| Max. operating height above sea level | 2000 m |
| Airgap creepage | |
| In accordance with the standard | EN 60664-1 |
| Overvoltage category | III |
| Protection type | |
| Mounting area (e.g. control cabinet) | IP54 |
| Housing | IP20 |
| Terminals | IP20 |
| Potential isolation | |
| Potential isolation between | 2-pole semiconductor outputs and system voltage |
| Type of potential isolation | Basic insulation |
| Mechanical data | |
| Mounting position | Horizontal on top hat rail |
| Material | |
| Bottom | PC |
| Front | PC |
| Top | PC |
| Connection type | Spring-loaded terminal |

Safety relays PNOZsigma PNOZ s50

| Mechanical data | |
|--|---|
| Mounting type | plug-in |
| Conductor cross section with spring-loaded terminals: Flexible with/without crimp connector | 0,2 - 2,5 mm ² , 24 - 12 AWG |
| Spring-loaded terminals: Terminal points per connection | 2 |
| Stripping length with spring-loaded terminals | 9 mm |
| Dimensions | |
| Height | 100 mm |
| Width | 45 mm |
| Depth | 120 mm |
| Weight | 255 g |

The standards current on 2013-03 apply.

Safety characteristic data

| Operating Mode | EN ISO 13849-1: 2015 | EN ISO 13849-1: 2015 | EN 62061 SIL CL | EN 62061 PFH _D [1/h] | IEC 61511 SIL | IEC 61511 PFD | EN ISO 13849-1: 2015 T _M [year] |
|----------------|----------------------|----------------------|-----------------|---------------------------------|---------------|---------------|--|
| | PL | Category | | | | | |
| All | PL e | Cat. 4 | SIL CL 3 | 7,83E-10 | SIL 3 | 6,81E-05 | 20 |

All the units used within a safety function must be considered when calculating the safety characteristic data.

The safety-related characteristic data (PFH, PFD) are mean values. They have been calculated at an average ambient component temperature of 40 °C and apply for the ambient temperature range stated in the technical details.

Safety relays PNOZsigma PNOZ s50

Supplementary data

The max. permitted load current at the power circuits O1+/O1- and O2+/O2- depends on the

- ▶ Ambient temperature.
- ▶ Distance between the PNOZ s50 and adjacent devices.
- ▶ Number of power circuits connected (one or two).
- ▶ Size of the supply voltage to the power circuits at B1/B2.

| Distance re-quired between adjacent devices | Ambient temperature | Number of power circuits | Max. permitted output current at $U_{B1/B2} = 24\text{ V}$ | Max. permitted output current at $U_{B1/B2} = 48\text{ V}$ |
|---|---------------------|--------------------------|--|--|
| Yes | 45°C | 1 | 6.5 A | 3.25 A |
| Yes | 55°C | 1 | 5.5 A | 2.75 A |
| Yes | 45°C | 2 | 4.5 A | 2.25 A |
| Yes | 55°C | 2 | 4.0 A | 2.0 A |
| No | 45°C | 1 | 6.0 A | 3.0 A |
| No | 55°C | 1 | 5.0 A | 2.5 A |
| No | 45°C | 2 | 4.0 A | 2.0 A |
| No | 55°C | 2 | 3.5 A | 1.75 A |

Use of the devices in accordance with UL

| Ambient temperature | Number of power circuits | Max. permitted output current at $U_{B1/B2} = 24\text{ V}$ | Max. permitted output current at $U_{B1/B2} = 48\text{ V}$ | Utilisation category |
|---------------------|--------------------------|--|--|----------------------|
| 45°C | 1 | 6.5 A | 3.25 A | Pilot Duty |
| 55°C | 1 | 5.5 A | 2.75 A | |
| 45°C | 2 | 4.5 A | 2.25 A | |
| 55°C | 2 | 4.0 A | 2.0 A | |

When using the devices in accordance with UL, please note the following:

- ▶ The ambient temperature is understood to be the *Surrounding Air Temperature*.
- ▶ Appropriate measures e.g (tempering of the control cabinet) should be used to ensure that the stated values are maintained when devices are installed without a distance.

Safety relays PNOZsigma PNOZ s50

Order reference

Order references Module

| Product type | Terminals | Order no. |
|--------------|-------------------------|-----------|
| PNOZ s50 C | Spring-loaded terminals | 751 500 |

Order references Accessories

Chip cards and chip card reader

| Product type | Features | | | Order No. |
|--|--|-------|-----------|-----------|
| PNOZmulti Chipcard | Chip card | 32 kB | | 779 211 |
| PNOZmulti Chipcard Set | Chip card | 32 kB | 10 pieces | 779 212 |
| Chipcard Holder | Chip card holder | | | 779 240 |
| PNOZmulti Seal | Chip card seal | | 10 pieces | 779 250 |
| PNOZ Chip Card Reader | Chip card reader for saving the configuration on the computer | | | 779 230 |
| SmartCardCommander with SIM card adapter | Software for the chip card reader 779 230, for saving the configuration on the computer | | | 750 031 |
| PNOZsigma Chip Card manager set | Set consisting of the PNOZ Chip Card Reader and SmartCardCommander with SIM card adapter (779 230 and 750 030) | | | 750 030 |

Terminals

| Product type | Features | | | Order No. |
|---|--|--|---------|-----------|
| PNOZ s Set1 Spring Loaded Terminals 45 mm | Set of plug-in spring-loaded terminals | | 1 piece | 751 008 |

Support

Technical support is available from Pilz round the clock.

Americas

Brazil

+55 11 97569-2804

Canada

+1 888-315-PILZ (315-7459)

Mexico

+52 55 5572 1300

USA (toll-free)

+1 877-PILZUSA (745-9872)

Asia

China

+86 21 60880878-216

Japan

+81 45 471-2281

South Korea

+82 31 450 0680

Australia

+61 3 95446300

Europe

Austria

+43 1 7986263-0

Belgium, Luxembourg

+32 9 3217575

France

+33 3 88104000

Germany

+49 711 3409-444

Ireland

+353 21 4804983

Italy

+39 0362 1826711

Scandinavia

+45 74436332

Spain

+34 938497433

Switzerland

+41 62 88979-30

The Netherlands

+31 347 320477

Turkey

+90 216 5775552

United Kingdom

+44 1536 462203

You can reach our international hotline on:

+49 711 3409-444

support@pilz.com

Pilz develops environmentally-friendly products using ecological materials and energy-saving technologies. Offices and production facilities are ecologically designed, environmentally-aware and energy-saving. So Pilz offers sustainability, plus the security of using energy-efficient products and environmentally-friendly solutions.

The 4-fold safety of automation

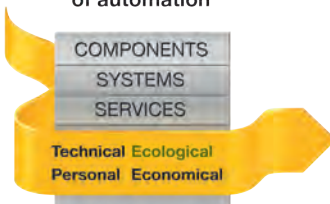

Presented by:

Energy saving by Pilz



Pilz GmbH & Co. KG
Felix-Wankel-Straße 2
73760 Ostfildern, Germany
Tel.: +49 711 3409-0
Fax: +49 711 3409-133
info@pilz.com
www.pilz.com

PILZ
THE SPIRIT OF SAFETY